

## Standard Features

- Heavy-gauge steel with a durable powder coat finish or stainless steel
- Steering wheels and double loading polyurethane rollers
- Four stainless steel IP68 load cells
- Weight indicator in IP65 stainless steel water-resistant enclosure
- Large 25 mm LCD display high contrast digits and waterproof membrane keyboard with 17 functional keys
- Configuration, calibration and diagnostics from keyboard
- Rechargeable battery mounted on the pallet jack
- Battery life is 80 hours of continuous use or one month of non-continuous use
- Zero and tare functions
- Accumulation
- Formulation
- +/- Checkweighing
- Percentage weighing
- Counting (Max. resolution of 1.500.000 divisions)
- Peak hold
- Includes a 115VAC 50/60 Hz battery charger

## Specifications

### Forks Dimensions:

1.630mm X 550mm X 1.200mm  
(LxWxH)

### Weight:

134kg

### Capacity:

Maximum lifting capacity 2.000kg

### Accuracy:

± 0.1% of the maximum capacity

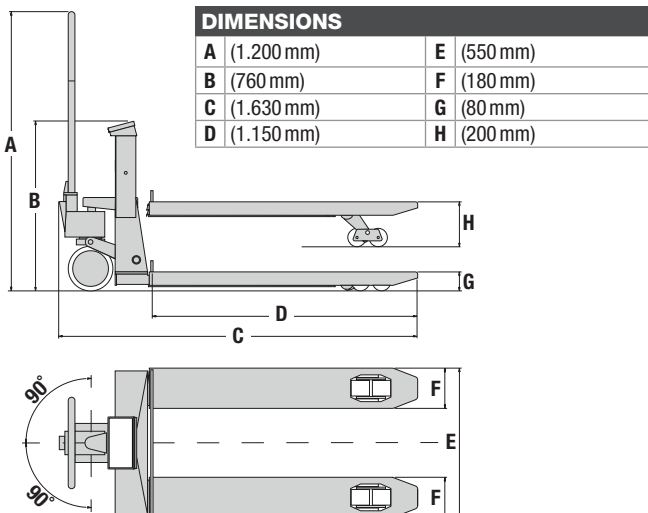

# RL-HPJ

## Hand Pallet Jack Scale

Weigh and transport pallets in one streamlined process with Rice Lake's hand pallet jack scales. Available in stainless steel or heavy-gauge steel with a powder coat finish, the RL-HPJ offers maximum precision for tracking shipping and receiving weights. Battery power keeps the weighing and transport process moving, while the integrated digital indicator provides a clear weight readout in any lighting condition. With a Rice Lake pallet jack scale, material handling is faster and more efficient for your warehouse.

# RL-HPJ

Hand Pallet Jack Scale

**RICE LAKE**  
WEIGHING SYSTEMS



 **CAPACITY: 2.00kg**  
**DIVISION: 1kg**