

ISHIDA WM-Ai

Automatic Wrapper

15th Edition

Service Manual

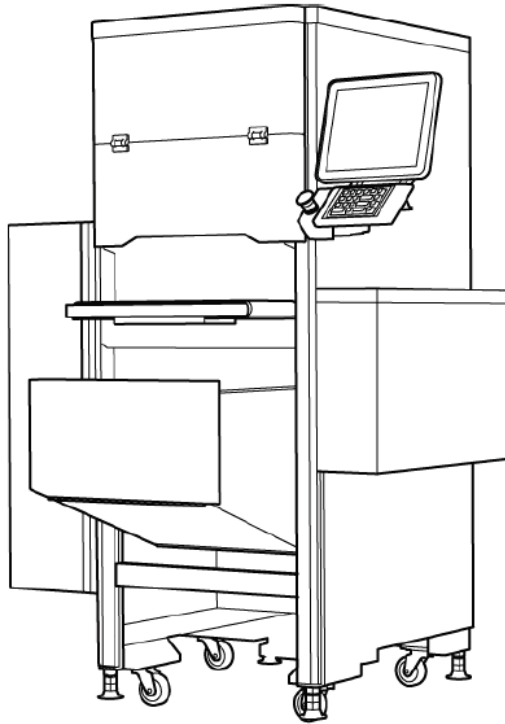

An ISO 9001 registered company
© Rice Lake Weighing Systems. All rights reserved.

Rice Lake Weighing Systems® is a registered trademark of
Rice Lake Weighing Systems.

All other brand or product names within this publication are trademarks or
registered trademarks of their respective companies.

All information contained within this publication is, to the best of our knowledge, complete and
accurate at the time of publication. Rice Lake Weighing Systems reserves the right to make
changes to the technology, features, specifications and design of the equipment without notice.

The most current version of this publication, software, firmware and all other product
updates can be found on our website:

www.ricelake.com

Revision History

Version	Date	Description
1	February, 2015	1 st edition
2	May, 2015	Reflected specifications changes. Corrected erroneous description.
3	July, 2015	Revise Chapter 2 Mechanical Adjustment
4	September, 2015	Revise Chapter 2 Mechanical Adjustment
5		Skipped of unifying a Japanese version.
6	May, 2016	Corrected erroneous description.
7	September, 2016	Corrected erroneous chapter 1 Specifications. Added Chapter 2 Disassembling, Assembling, and Adjusting the suction unit. Added Chapter 3 Parts number. Changed contents in each chapter.
8		Skipped of unifying a Japanese version.
9	March, 2017	Added Chapter 1 Installation, chapter 2 Lift unit and Cutter unit.
10	January, 2019	1.8 Installation <ul style="list-style-type: none"> Divided into a checksheet (for the power on) and a setup. Revised the procedure for the change of checksheet. Added the explanation for Jack up. 1.9 SETUP <ul style="list-style-type: none"> Added the checksheet and revised the procedure. Revised the procedure for the change of checksheet. 2.2.2.1 Checking the coiled cord mounting status <ul style="list-style-type: none"> Added check items. 2.2.2.4 Automatically adjusting the suction position using label size <ul style="list-style-type: none"> Added check items. 2.2.3.3 Countermeasures to "Insertion open/close is not set" errors <ul style="list-style-type: none"> Added Subsubsection 2.2.3.3 Countermeasures to "Insertion open/close is not set" errors. 2.2.10.4 Adjusting the film cutter <ul style="list-style-type: none"> Added Subsubsection 2.2.10.4 Adjusting the film cutter.
11	March, 2019	Added Section 1.7 Power Supply. Moved Chapter 6 Trouble Shooting to HTML version and deleted from this service manual.
12	October, 2019	Changed the last two digits of the part numbers described in this manual to **. 1.9.2 Checksheet <ul style="list-style-type: none"> Deleted the specifications without mount in step 19. 1.10 Upgrading the Program <ul style="list-style-type: none"> Deleted "1.10.2 Backing up the device software". 2.2.11 Roll Hold Unit <ul style="list-style-type: none"> Added "2.2.11.2 Change of BEARING UNIT:FLANGE: for Film Holding Rod". Added "2.2.11.3 How to Replace the Bearing Unit". 2.3.3 Feeder Unit <ul style="list-style-type: none"> Added "2.3.3.6 Change of Feeder Flat Belt" Added "2.3.3.7 Installation of Rail Warp Countermeasure Parts"
13	April, 2020	4.14.1 Operation Setting <ul style="list-style-type: none"> Added "Torque Wrapping PLU".
14	July, 2020	8.3 Wiring Diagrams <ul style="list-style-type: none"> Wiring Diagrams are replaced.
15	July, 2020	7.3.2 Installation Procedure <ul style="list-style-type: none"> Figure of Step.2 is replaced. 8.3 Wiring Diagrams <ul style="list-style-type: none"> Wiring Diagrams are refined.

Introduction

● Purpose of this Manual

The purpose of this manual is as reference material for the delivery, installation, repair and maintenance of this machine.

● Target Readers

This manual has been written specifically for use by our service personnel.



The use of this manual by any person other than the above is strictly prohibited.



● Related Manuals

Manual Name	Content
WM-AI Moving Image Manual	Gives an overall machine explanation and explanation of operations that are not easily understood with by manual.
WM-AI Instruction Manual	Instruction Manual (included in the package of this machine)

● Signal Words

The signal words shown in this manual are separated into two stages depending on the level of danger or the seriousness of potential injury. Fully understand the meanings of the signal words shown below and follow the directions as shown in this manual and on the stickers placed about the machine.

Signal Word	Meaning
 DANGER!	Indicates an imminently hazardous situation which, if not avoided, is likely to result in serious injury or may result in death.
 WARNING	Indicates a potentially hazardous situation which, if not avoided, will result in minor or moderate injury, or may result in serious injury or death.
 CAUTION	Indicates a potentially hazardous situation, which, if not avoided, may result in minor or moderate injury or in property damage.

Note:	Indicates information that needs to be noted or emphasized.
 INFORMATION	Indicates reference information when performing an operation.
 REFERENCE	Indicates the reference page related to performance of an operation.

It is strictly prohibited to copy or reproduce part or all of this manual without prior approval by the copyright holder.

Notes on Software

Dedicated software is installed in this machine to meet the customer's needs.

Software can be divided into the following two programs:

- **Application Program**

"Application program" independently designed by our company runs to execute actual operations of this machine such as key input, display, printing, etc.) in accordance with the predetermined procedures.

- **NOTICE AND LICENSES FOR SOFTWARE USED IN THIS PRODUCT**

This product contains software that is subject to the following GNU General Public License("GPL") or GNU Lesser General Public License ("LGPL"). These establish that customers have the right to acquire, modify, and redistribute the source code of said software in accordance with the items of the GPL or the LGPL.

Package List

Linux Kernel, Ubuntu, freetype, Ixde, PCMan File Manager, Leafpad, openbox, MPlayer, Xarchiver, ibus, anthy, ALSA, curl, CurlFtpFS, Qt, libusb

The source code for the above-listed software is available. Please access the following.

Ishida. Co., Ltd. (Headquarters, Japan)

<https://www.ishida.com>

Phone: +81-75-771-4141

GNU General Public License, version 2

<http://www.gnu.org/licenses/old-licenses/gpl-2.0.en.html>

GNU Lesser General Public License, version 2.1

<http://www.gnu.org/licenses/old-licenses/lgpl-2.1.en.html>

Table of Contents

Revision History	2
Introduction	3
Table of Contents.....	5
Chapter 1 Overview.....	1-1
1.1 Specifications	1-1
1.1.1 General Specifications	1-1
1.1.2 Wrapping Unit Specifications.....	1-2
1.1.3 Tray Detector Performance	1-3
1.1.4 Operation Unit Specifications	1-3
1.1.5 Printer Unit Specifications.....	1-4
1.1.6 Weighing Unit Specifications	1-4
1.1.7 Label Applicator Performance	1-5
1.1.8 Options.....	1-5
1.1.9 Reliability/ Product Life/Standard.....	1-6
1.1.10 Memory	1-7
1.2 Features	1-10
1.3 Part Name.....	1-11
1.3.1 External Dimensions	1-11
1.4 Dimension	1-13
1.4.1 External Dimensions	1-13
1.5 Package Content.....	1-15
1.5.1 Checking the Package Content	1-15
1.6 Items Required for Installation	1-15
1.6.1 Checking Tools for Installation.....	1-15
1.6.2 Checking the Installation Environment	1-16
1.6.3 Installation Space.....	1-16
1.7 Power Supply.....	1-17
1.7.1 Cable length from terminal block to Skin top.....	1-18
1.8 Installation.....	1-19
1.8.1 Checksheet (until the power supply is turned ON).....	1-20
1.8.2 Detaching the In-feed Unit	1-21
1.8.3 Jack up.....	1-21
1.9 SETUP	1-22
1.9.1 Items Required for Setup.....	1-22
1.9.2 Checksheet	1-22
1.10 Upgrading the Program.....	1-24
1.10.1 Preparation.....	1-24
1.10.2 Upgrading Software on the Main Machine	1-24
1.10.3 Upgrading the Sub Application	1-24
1.10.4 Adjusting the film spikes	1-25
1.10.5 Adjusting the position at the front and back of the film roll (securing position)	1-26

1.10.6	Setting the film roll brake	1-28
1.10.7	Camera adjustments.....	1-30
1.10.8	Tray presser height adjustments	1-32
1.10.9	Printer adjustments.....	1-33
1.10.10	Applicator adjustments.....	1-36
1.10.11	Operation Check	1-37
1.10.12	Instruction Manual.....	1-37
1.10.13	Warranty Card.....	1-37
1.10.14	Setups	1-37
Chapter 2	Mechanical Adjustment	2-1
2.1	Overview	2-1
2.1.1	Applicator Unit.....	2-1
2.1.2	Feeder Unit	2-3
2.1.3	Camera Unit.....	2-5
2.1.4	Lift Unit	2-7
2.1.5	Electromagnetic Brake.....	2-8
2.2	Adjusting the Mechanical Units.....	2-9
2.2.1	Printer Unit	2-9
2.2.2	Applicator unit	2-24
2.2.3	Feeder Unit	2-32
2.2.5	In-feed Unit.....	2-45
2.2.6	Camera Unit.....	2-46
2.2.7	Lift Unit	2-49
2.2.8	Wrapping Unit	2-62
2.2.9	Heater Unit.....	2-73
2.2.10	Cutter Unit.....	2-74
2.2.11	Roll Hold unit.....	2-77
2.3	Replacement the Mechanical Units	2-81
2.3.1	Printer Unit	2-81
2.3.2	Applicator Unit.....	2-86
2.3.3	Feeder Unit	2-120
2.3.4	In-feed Unit.....	2-126
2.3.5	Lift Unit	2-127
2.3.6	Heater Unit.....	2-130
2.3.7	Cutter Unit	2-133
2.3.8	Electromagnetic Brake.....	2-135
Chapter 3	Electric Components	3-1
3.1	Electric Unit Configuration.....	3-1
3.1.1	Overview	3-1
3.1.2	Back Side of the Machine	3-3
3.1.3	Right Side of the Machine.....	3-4
3.1.4	Left Side of the Machine	3-5
3.2	Main board	3-6
3.2.1	Replacing the Main board.....	3-6
3.3	Sensor	3-8

Chapter 4	Setup Mode	4-1
4.1	Startup	4-1
4.2	MACHINE NO. SETTING	4-3
4.2.1	MACHINE No. (BASIC)	4-3
4.2.2	MACHINE No. (IP ADDR.)	4-4
4.2.3	MACHINE No. (PC COM)	4-5
4.2.4	MACHINE No. (WiFi)	4-6
4.2.5	MACHINE No. (GLOBAL SV.)	4-7
4.2.6	MACHINE No. (SYNC.)	4-8
4.2.7	MACHINE No. (OUTSIDE PRINTER)	4-9
4.3	PASSWORD	4-10
4.3.1	PASSWORD (OPERATE)	4-10
4.4	KEY LOCK	4-11
4.4.1	KEY LOCK (DISPLAY KEY)	4-11
4.4.2	KEY LOCK (FUNCTION KEY)	4-12
4.4.3	KEY LOCK (STROKE KEY)	4-13
4.5	DATA STORAGE	4-14
4.5.1	DATA STORAGE (TOTAL ADD.)	4-14
4.5.2	DATA STORAGE (TOTAL PROC.)	4-15
4.5.3	DATA STORAGE (TRANSACTION)	4-16
4.5.4	DATA STORAGE (STORAGE)	4-17
4.6	PLU OVERWRITE	4-18
4.7	PLU INITIAL DATA	4-19
4.7.1	PLU INITIAL DATA (SALE1)	4-19
4.7.2	PLU INITIAL DATA (MSG.)	4-20
4.7.3	PLU INITIAL DATA (IMAGE)	4-21
4.7.4	PLU INITIAL DATA (PRINT)	4-22
4.7.5	PLU INITIAL DATA (DATE)	4-23
4.7.6	PLU INITIAL DATA (CODE)	4-24
4.7.7	PLU INITIAL DATA (WRAP)	4-25
4.8	PLU UPDATE	4-26
4.9	LABEL COMB.	4-27
4.9.1	LABEL COMB. (BASIC)	4-28
4.9.2	LABEL COMB. (LABEL)	4-29
4.9.3	LABEL COMB. (UPPER FIX)	4-31
4.9.4	LABEL COMB. / DETAIL	4-32
4.10	LABEL FORMAT	4-33
4.10.1	LABEL FORMAT / PRINT CONTROL	4-34
4.10.2	LABEL FORMAT / DETAIL (BASIC)	4-35
4.10.3	LABEL FORMAT / DETAIL (UNIT)	4-37
4.10.4	LABEL FORMAT / DETAIL (PREVIEW)	4-38
4.11	BARCODE	4-39
4.11.1	BARCODE (POS FLAG)	4-39
4.11.2	BARCODE (POS CODE)	4-40
4.11.3	BARCODE (ITEM CODE)	4-41

4.12 CUSTOM BARCODE	4-42
4.12.1 CUSTOM BARCODE (BASIC)	4-43
4.12.2 CUSTOM BARCODE (PREVIEW)	4-44
4.13 MENU TITLE	4-45
4.13.1 MENU TITLE (OPERATE)	4-45
4.14 OPERATION SETTING	4-46
4.14.1 OPERATION SETTING (CALL1)	4-46
4.14.2 OPERATION SETTING (CALL2)	4-47
4.14.3 OPERATION SETTING (PROD.)	4-48
4.14.4 OPERATION SETTING (PRINT.)	4-49
4.15 ERROR PROCESS	4-50
4.15.1 ERROR PROCESS (ISSUE)	4-50
4.15.2 ERROR PROCESS (CALL)	4-51
4.15.3 ERROR PROCESS (COMMON)	4-52
4.16 ERROR LOG	4-53
4.16.1 ERROR LOG (DISPLAY)	4-53
4.17 TRACE	4-54
4.18 DUAL CURRENCY	4-55
4.19 PRICE ROUNDING	4-56
4.20 FREQUENT SHOPPER	4-57
4.21 STANDBY MODE	4-58
4.22 COUNTRY	4-59
4.22.1 COUNTRY / DETAIL (CURRENCY)	4-60
4.22.2 COUNTRY / DETAIL (WEIGHT)	4-61
4.22.3 COUNTRY / DETAIL (DATE)	4-62
4.23 FILE SAVE /LOAD	4-63
4.23.1 FILE SAVE/LOAD (USB>SCALE)	4-63
4.23.2 FILE SAVE/LOAD (SCALE>USB)	4-65
4.23.3 FILE SAVE/LOAD (USB DATA DEL.)	4-67
4.23.4 FILE SAVE/LOAD (SCALE INIT.)	4-69
4.23.5 FILE SAVE/LOAD / DETAIL	4-70
Chapter 5 Adjust Mode	5-1
5.1 Startup	5-1
5.2 DATE TIME	5-3
5.3 TOUCH SCREEN	5-5
5.4 DISPLAY CHECK	5-6
5.5 SOUND	5-7
5.6 KEY CHECK	5-8
5.7 FIRMWARE DETAILS	5-9
5.8 MEMORY CLEAR	5-10
5.9 PRINTER	5-12
5.9.1 PRINTER (HEAD)	5-12
5.9.2 PRINTER (PEEL SENSOR)	5-14
5.9.3 PRINTER (LABEL TYPE)	5-15
5.9.4 PRINTER (LABEL FEED)	5-16

5.10 CALIBRATION	5-18
5.11 MACHINE TYPE	5-19
5.11.1 MACHINE TYPE / DETAIL	5-20
5.12 DOWNLOAD	5-22
5.12.1 DOWNLOAD (MAIN)	5-22
5.12.2 DOWNLOAD (SUB APP.).....	5-23
5.12.3 DOWNLOAD (SUB BOOT).....	5-24
5.13 OPTION CHECK	5-25
5.13.1 OPTION CHECK (SCANNER)	5-25
5.13.2 OPTION CHECK(USB).....	5-26
5.13.3 OPTION CHECK (DEVICE).....	5-27
5.14 WRAPPNG MACHINE	5-28
5.14.1 WRAPPNG MACHINE (FILM).....	5-28
5.14.2 WRAPPNG MACHINE (LIFT).....	5-30
5.14.3 WRAPPNG MACHINE (ROLL).....	5-31
5.14.4 WRAPPNG MACHINE (INITIAL).....	5-33
5.14.5 WRAPPNG MACHINE (EJECTION)	5-34
5.15 CAMERA	5-35
5.15.1 CAMERA (BASIC)	5-35
5.15.2 CAMERA (ADJUSTMENT).....	5-37
5.15.3 CAMERA (BLINK).....	5-38
5.15.4 CAMERA (OFFSET).....	5-39
5.15.5 CAMERA (SPC.).....	5-41
5.15.6 CAMERA (HUMAN).....	5-42
5.15.7 CAMERA (VOLUME).....	5-43
5.16 LABEL APPLICATOR	5-44
5.16.1 LABEL APPLICATOR (POS.).....	5-44
5.16.2 LABEL APPLICATOR (ACTION).....	5-46
5.16.3 LABEL APPLICATOR (INIT.).....	5-47
5.17 UNIT ACTION	5-49
5.17.1 UNIT ACTION (WRAP).....	5-49
5.17.2 UNIT ACTION (LABEL APP.).....	5-50
5.18 DISPLAY CAPTURE	5-51
5.19 GRAVITY	5-52
Chapter 6 Trouble Shooting	6-1
6.1 Operation as IP (scale and printer)	6-1
6.2 Error Message	6-2
6.2.1 Error Screen	6-2
6.3 System Error	6-3
6.3.1 System-related Error (No. 100s)	6-3
6.3.2 Memory-related Error (No. 200s)	6-14
6.3.3 Precheck-related Error (No. 300s).....	6-44
6.3.4 Wrapper-related Error (No. 400s, 500s).....	6-80
6.3.5 Applicator-related Error (No. 600s).....	6-153
6.3.6 Printer-related Error (No. 700s, 800s)	6-173
6.3.7 Detector-related Error (No. 1500s).....	6-187

6.3.8	Scale-related Error (No. 1600s)	6-200
6.3.9	Dialog Selection-related Error (No. 1800s, 4200s)	6-204
Chapter 7	Options	7-1
7.1	Static Elimination Rope	7-1
7.2	LAN Cable Wiring	7-2
7.2.1	Wiring Procedure	7-2
7.3	Wi-PORT	7-5
7.3.1	Package Content	7-5
7.3.2	Installation Procedure	7-5
7.4	Human Detection Sensor (J)	7-13
7.4.1	Package Content	7-13
7.4.2	Installation Procedure	7-14
7.5	Human Detection Sensor (Standard)	7-16
7.5.1	Package Content	7-16
7.5.2	Installation Procedure	7-16
7.6	On-board Lighting	7-18
7.6.1	Package Content	7-18
7.6.2	Installation Procedure	7-18
7.7	File Stand	7-20
7.7.1	Package Content	7-20
7.7.2	Installation Procedure	7-20
Chapter 8	Appendix	8-1
8.1	Operation Sequence	8-1
8.1.1	At Start-up	8-1
8.1.2	When Issuing Labels	8-4
8.2	Software License	8-9
8.2.1	GNU General Public License Version 2, June 1991	8-9
8.2.2	GNU Lesser General Public License Version 2.1, February 1999	8-15
8.3	Wiring Diagrams	8-23
8.3.1	PAGE 1	8-23
8.3.2	PAGE 2	8-24
8.3.3	PAGE 3	8-25
8.3.4	PAGE 4	8-26
8.3.5	PAGE 5	8-27
8.3.6	PAGE 6	8-28
8.3.7	PAGE 7	8-29
8.3.8	PAGE 8	8-30
8.3.9	PAGE 9	8-31
8.3.10	PAGE 10	8-32
8.3.11	PAGE 11	8-33

Chapter 1 Overview

1.1 Specifications

1.1.1 General Specifications

Item	Specifications
Model	◇WM-AI
Product category	◇Auto scale wrap price labeling system (push-up type stretch wrapper)
Product lineup	◇Dual film, Printer Dual Auto Labeling Type (AT2) ◇Single film, Printer Dual Auto Labeling Type (AT1) ◇Dual film, Printer Single Auto Labeling Type (AS2) ◇Single film, Printer Single Auto Labeling Type (AS1) The JR (front stock and right discharge) type is prepared for each.
Environmental Conditions	◇Temperature: 5°C to 35°C ◇Humidity: 20% to 85% (Non condensing)
Dimensions	◇Width: 1000 mm (standard type), 1130 mm (J type, R turn) ◇Depth: 1120 mm/ main body frame: 800 mm ◇Height: 1635 mm (when caster grounded) Jack up +50 mm
Exterior	◇Stainless (a portion :resin molded)
Power supply	◇Single phase 200 to 240 V AC (+5%/-10%) 10 A (max. in normal operation) ◇No need to change parts in accordance with the power supply frequency.
Packs per minute	◇35 packs per minute (max.)
Weight for wrapping capacity	◇20g to 6 kg / to 4.5 kg (Weight limit when a tray is fed. When a wrapped item is fed.)
Weight for weighing capacity	◇40g to 15 kg <North America> ◇20g to 6 kg <Europe>
Machine weight	◇363 kg (AT2) ◇404 kg or less (AT2JR)
Noise	◇74.6dB or less

1.1.2 Wrapping Unit Specifications

Item	Specifications
Wrapping method	◇Prestretch wrapping method
Wrapping size	◇Width: 95 to 380 mm (bottom 60 mm or more) Depth: 80 to 260 mm (bottom 60 mm or more) Height: 10 to 130 mm (tray height: 70 mm or less) ◇Wrapping not available in some combinations. However, wrapping is possible for 1014 tray (360 x 254 x 30 mm) and 25SH tray (378 x 205 x 30 mm)
Tray material	◇PSP, CTF, PP, PET, paper
Tray shape	◇Rectangle, corner cut, fan-shaped, round-shaped, tray with legs, bottom raising tray. ◇A tray with legs and bottom raising tray may not be able to be used depending on their shapes and dimensions.
Film size	◇Nominal width: 250/ 300/ 350/ 400/ 450/ 500/ 533 mm (21 inch) ◇Max. stretch width: 600 mm ◇Max. film feeding length: 700 mm ◇Stretch of general recommended film: 30% ◇The maximum stretch amount for ISHIDA UP grade is up to 100%. There is a limit depending on the film type.
Outside diameter of the film	◇Polyethylene film: 200 mm max. ◇Polyvinyl chloride film: 200 mm max. ◇Internal diameter of paper tube: 76 mm
Film type	◇Polyolefin, polyvinyl chloride (for winding machine)
Recommended film	◇DIAWRAP MS-I ◇DIAWRAP SUPER ◇DIAWRAP A50
In-feed carrier method	◇Push bar carrier method (with tray centering mechanism)
Film switching method	◇Upper/ lower two films automatic switching
Lift changeover method	◇Auxiliary lift connection method (depth direction) Lift: large or small are selectable.
Film carrier method	◇Belt carrier, Film all cut method
Film welding	◇Heater compression method
Cleaning	◇Lift head is detachable (washable except for moving parts of the head) ◇Platter is detachable (washable) ◇Centering conveyor is detachable ◇Heater dust saucer is detachable (washable) ◇In-feed unit is drawable
Operability	◇Wrap setting ◇Setting data that contains film name and size information for wrapping can be input/output in CSV file.

1.1.3 Tray Detector Performance

Item	Specifications
Tray detection method	◇Dimension detection method by color CMOS camera
Tray detection range	◇Long side x short side x height: 380 mm x 260 mm x 70 mm ◇Rectangle tray except blue and transparent trays * Circular and fan shape are not supported. ◇ A tray may not be detected if the edge of the tray is hidden by a product. ◇ For a tray with the height of 50 mm or higher, the placement position of the width direction is limited.
Light for tray detection	◇2 white LEDs

1.1.4 Operation Unit Specifications

Item	Specifications
Display	◇12.1 inch TFT color SVGA LCD (800 × 600) ◇A numeric keypad cover is included.
Input unit	◇Analog touch panel of thin film resistive system.
No. of register items	◇10000 product masters
Standard input/output	◇1000BASE-T LAN: 1ch ◇USB 2.0: 4ch
Main board	◇P-1163 board
OS	◇Linux
Location of the operation unit	◇At the right side of the machine

1.1.5 Printer Unit Specifications

Item	Specifications																			
Print speed	◇120 mm/ sec																			
Label size	Machine No.1 (left) ◇Width: 35 to 80 mm ◇Top/ Bottom: 27 to 105 mm		Dual machine No.2 (right) ◇Width: 35 to 80 mm ◇Top/ Bottom: 27 to 60 mm																	
Maximum print width	◇Spec. with label mount: Width 76 mm																			
Thermal head	◇3 inch (960dot), 12dot/ mm thermal head																			
Diameter of label roll	◇Internal diameter of paper tube: 76 mm ◇Maximum external diameter: 230 mm																			
No. of storage label	◇Spec. with label mount: 6000 labels (Top/Bottom 37 mm, label pitch 2.2 mm)																			
Recommended label	ISHIDA specific label																			
Printing accuracy	<table border="1"> <thead> <tr> <th>Vertical</th> <th>Write position</th> <th>Expansion & contraction</th> <th>Shift amount = Write position + Expansion & contraction</th> <th>Meander</th> </tr> </thead> <tbody> <tr> <td>27 to 60</td> <td>±0.5</td> <td>±0.5</td> <td>±1.0</td> <td>±0.5</td> </tr> <tr> <td>60 to 105</td> <td>±0.5</td> <td>±1.0</td> <td>±1.5</td> <td>±0.5</td> </tr> </tbody> </table> <p style="text-align: right;">Unit: mm</p> <p>◇Two-dimensional codes are 4-dot/cell. * It may not be able to be recognized depending on the quality of the label.</p>					Vertical	Write position	Expansion & contraction	Shift amount = Write position + Expansion & contraction	Meander	27 to 60	±0.5	±0.5	±1.0	±0.5	60 to 105	±0.5	±1.0	±1.5	±0.5
Vertical	Write position	Expansion & contraction	Shift amount = Write position + Expansion & contraction	Meander																
27 to 60	±0.5	±0.5	±1.0	±0.5																
60 to 105	±0.5	±1.0	±1.5	±0.5																

1.1.6 Weighing Unit Specifications

Item	Specifications
Scale weight	<p><North America> 15 kg (Canada) 0 g or more but less than 6000 g – scale interval of 2 g, 6000 g or more but up to 15000 g – scale interval of 5 g (multi-interval)</p> <p><North America> 30 lb (USA) 0 lb or more but less than 15 lb – scale interval of 0.005 lb, 15 lb or more but up to 30 lb – scale interval of 0.01 lb (multi-interval)</p> <p><Europe> 6 kg 0 g or more but less than 3000 g – scale interval of 1 g, 3000 g or more but up to 6000 g – scale interval of 2 g (multi-interval)</p>
Weighting accuracy	◇1/3000 (Precision class based on new measurement standards in Japan: Class III)

1.1.7 Label Applicator Performance

Item	Specifications
Labeling method	◇Motor arm method (Arm rotation-type)
Applicator moving method	◇XY table carrier method
Applicable position for labeling	◇To the horizontal: Four corners To the left vertical: Four corners The pasting location is limited depending on the label length.
Applicable product size for labeling	◇Same as the wrapping size
Applicable label	◇Width: 35 to 80 mm ◇Top/Bottom: 27 to 105 mm The suction part does not need to be changed regardless of the label size.
Software specifications	◇Standard specifications (Specifications vary for each store.)
ASP (Application Service Provider)	Cloud enabled - Machine information collection - Remote maintenance
Remote maintenance	Machine settings can be checked and/or changed from the PC.
Compatibility with old machines	Performed using SLP (Service Location Protocol)
Communication with higher level devices	SLP supported
Sleep mode	The unit goes into sleep mode after a certain period of time if unused.

1.1.8 Options

Item	Specifications
Option	◇Wand scanner can be connected (USB connected scanner) ◇Product name file stand ◇Sub printer can be connected (Printer by BIXOLON) ◇Wireless LAN (WiPort) ◇Human detection sensor ◇Built-in lighting

1.1.9 Reliability/ Product Life/Standard

Item	Specifications
Product life	<ul style="list-style-type: none"> ◇5 years for use (consumable parts excluded) ◇Condition: 3000 packing/ day, 350 operating days (4200 hours) 5.25 million packing in five years.
Safety	<ul style="list-style-type: none"> ◇Conforming to ISHIDA product safety standards and warnings display standard. ◇Conforming to overseas standards <ul style="list-style-type: none"> <North America> ETL certified <Europe> CE marking compliant
Standards	<ul style="list-style-type: none"> ◇Conforming to ISHIDA product standards ◇Conforming to overseas standards <ul style="list-style-type: none"> <North America> ETL certified <Europe> CE marking compliant

1.1.10 Memory

The following table shows free space for saving 1 master data (1 record). The following master has memory area that is found by subtracting the area used in this program (4KB for fixed header) from 4MB of SRAM size.

Master name	Minimum size [BYTE]	Maximum size [BYTE]	Remarks
PLU	135	1251	The required size depends on the length of PLU name to be programmed. **"Minimum size" required when not programming character string of PLU name. "Maximum size" required when programming the max. of characters (510 characters).
UNIT PRICE	78		A unit price master is created for each product.
STORE	120	264	The required size depends on the character string length of store name and address to be programmed. **"Minimum size" required when not programming strings of store name and address. "Maximum size" required when programming the max. of characters (47 characters) for store name and address.
INGREDIENT	43	1159	The required size depends on the character string length of ingredient to be programmed. **"Minimum size" required when not programming character string of ingredient. "Maximum size" required when programming the max. of characters (510 characters).
POP	43	115	The required size depends on the character string length of POP to be programmed. **"Minimum size" required when not programming character string of POP. "Maximum size" required when programming the max. of characters (38 characters).
COMMENT	43	1159	The required size depends on the character string length of comment to be programmed. **"Minimum size" required when not programming character string of comment. "Maximum size" required when programming the max. of characters (510 characters).
PRODUCTION AREA	43	115	The required size depends on the character string length of Origin to be programmed. **"Minimum size" required when not programming character string of origin. "Maximum size" required when programming the max. of characters (38 characters).
STORAGE TEMPERATURE	43	295	The required size depends on the character string length of storage temperature to be programmed. **"Minimum size" required when not programming character string of storage temperature. "Maximum size" required when programming the max. of characters (118 characters).
STORAGE METHOD	43	295	The required size depends on the character string length of storage method to be programmed. **"Minimum size" required when not programming character string of storage method. "Maximum size" required when programming the max. of characters (118 characters).

Master name	Minimum size [BYTE]	Maximum size [BYTE]	Remarks
FIX PRICE SYMBOL	43	43	This is a variable length string; however, the required size remains unchanged as its programmable characters are up to 32 bytes. (No. of registered characters doesn't affect the required size)
CALORIE	43	1159	The required size depends on the character string length of calorie to be programmed. **"Minimum size" required when not programming character string of calorie. "Maximum size" required when programming the max. of characters (510 characters).
FREE	44	1160	The required size depends on the character string length of free to be programmed. **"Minimum size" required when not programming character string of free. "Maximum size" required when programming the max. of characters (510 characters).
PACK DATE TITLE	43	43	The required size depends on the character string length of free to be programmed. **"Minimum size" required when not programming character string of free. "Maximum size" required when programming the max. of characters (510 characters).
STORE TITLE	43	43	This is a variable length string; however, the required size remains unchanged as its programmable characters are up to 32 bytes. (No. of registered characters doesn't affect the required size)
CATEGORY	43	43	This is a variable length string; however, the required size remains unchanged as its programmable characters are up to 32 bytes. (No. of registered characters doesn't affect the required size)
TRAY	295	295	This is a variable length string; however, the required size remains unchanged as its programmable characters are up to 32 bytes. (No. of registered characters doesn't affect the required size)
FREE	43	43	This is a variable length string; however, the required size remains unchanged as its programmable characters are up to 32 bytes. (No. of registered characters doesn't affect the required size)
MEMO	7		
FORMAT	2065		
LABEL	32		
CASSETTE	7		
LABEL COMB.	154		
SALES PROMOTION	56		
ERROR LOG	27		
PRODUCTION AREA HISTORY	19		
PASSWORD	5		
ACTUAL RESULT	297		
TOTAL SALES	136		
TOTAL PER ITEM	48		
TOTAL PER HOUR	15		

Master name	Minimum size [BYTE]	Maximum size [BYTE]	Remarks
TRAY TOTAL		35	
INDIVIDUAL HISTORY		24	
LOT HISTORY		34	
HISTORY PER ITEM		102	
RETENTION		96	
RETAINED UNIT PRICE		78	
QR	51	2319	Currently unused

 Fixed length master

1.2 Features

- **Enhanced tray wrapping performance**
This machine uses trays of the sizes and shapes that correspond to market trends.
- **Genius wrapping**
The torque control motor for driving wrapping plates enables a higher wrapping performance. A tray can be prevented from being crashed in a wrapping route. The dedicated film can be stretched up to 200%.
- **Greater film pre-stretch ratio**
The film stretch ratio is improved from 120% (WM-4000) to 130% (WM-AI), providing a wider wrapping range for the same film width.
<Applicable films: general-purpose film ISHIDA wrap, ISHIDA wrap super etc.>
- **Ultra-stretch mechanism**
By taking the advantage of dual film, high wrapping performance can be maintained without deterioration in wrapping. With more stretchable wrap, various trays in size, from small to big, can be wrapped.
*Use the dedicated wrap (ISHIDA wrap UP).
- **Easy tray setting**
Automatic setting can be easily performed with the tray automatic detection with greater accuracy. A tab structure is also used on [PROGRAM] screen, which enables users to smoothly change the relevant screens one to another.
- **Around machine legs**
Simple design for easy cleaning. The lift drive part is provided inside the cover so that the cleaning is made easier. Likewise, previous model, its tray conveyance route is detachable.

1.3 Part Name

1.3.1 External Dimensions

Two film rolls
Auto-switching, auto setting

 : Operation panel

Main power switch

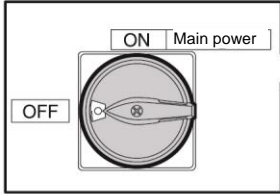

Label applicator arm

Front cover

Lift unit

Label printer

Touch panel

Stroke keys

Emergency stop switch

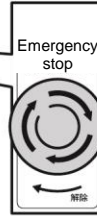
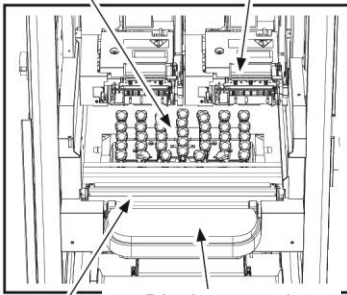

Discharge unit

Discharge (with CMOS camera) heater

Film replacement door

Infeed unit

Film removal door

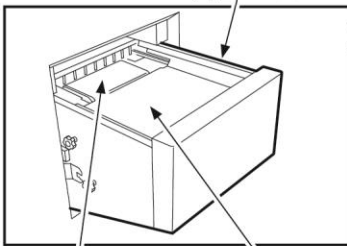

Jack

Caster

Centering conveyor

Weighing platter

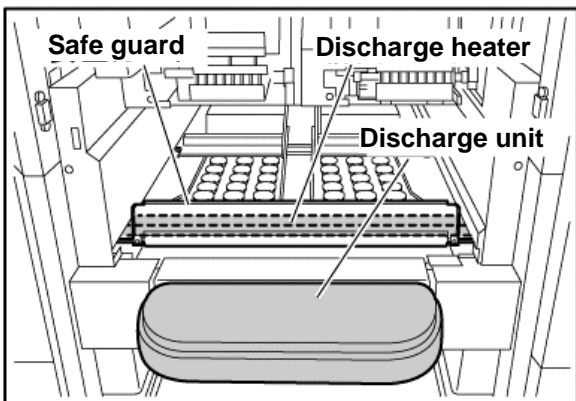

Safe guard

Discharge heater

Discharge unit

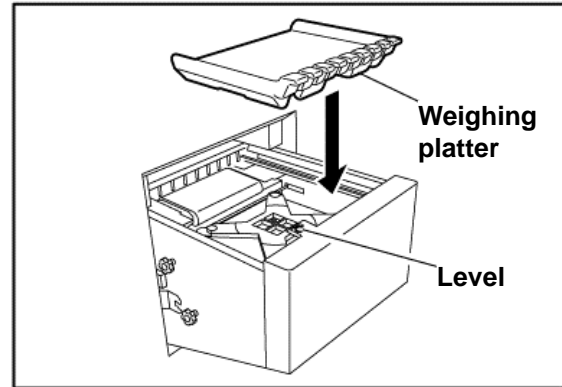
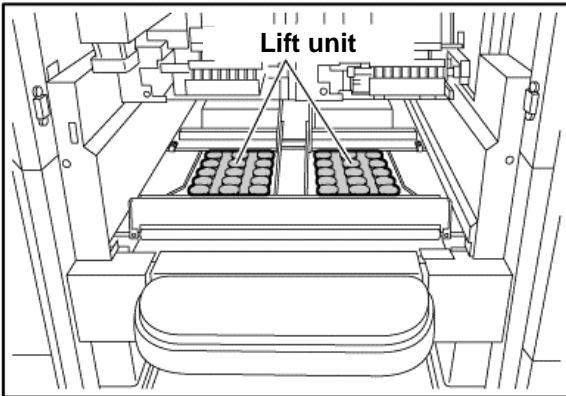
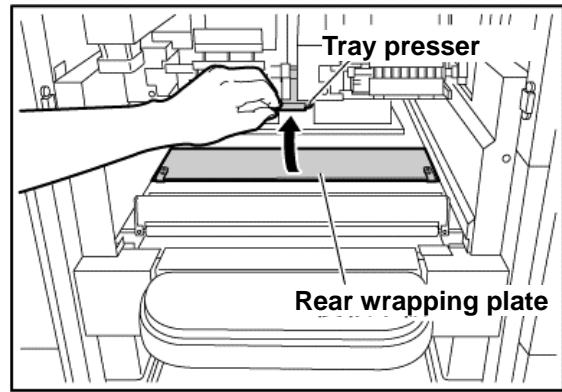
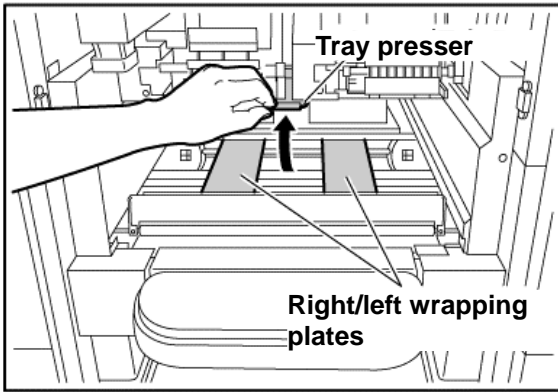

1.4 Dimension

1.4.1 External Dimensions

External dimensions are shown in the figures below. Secure a passage route and space for setup and maintenance.

1.4.1.1 Standard type external dimensions

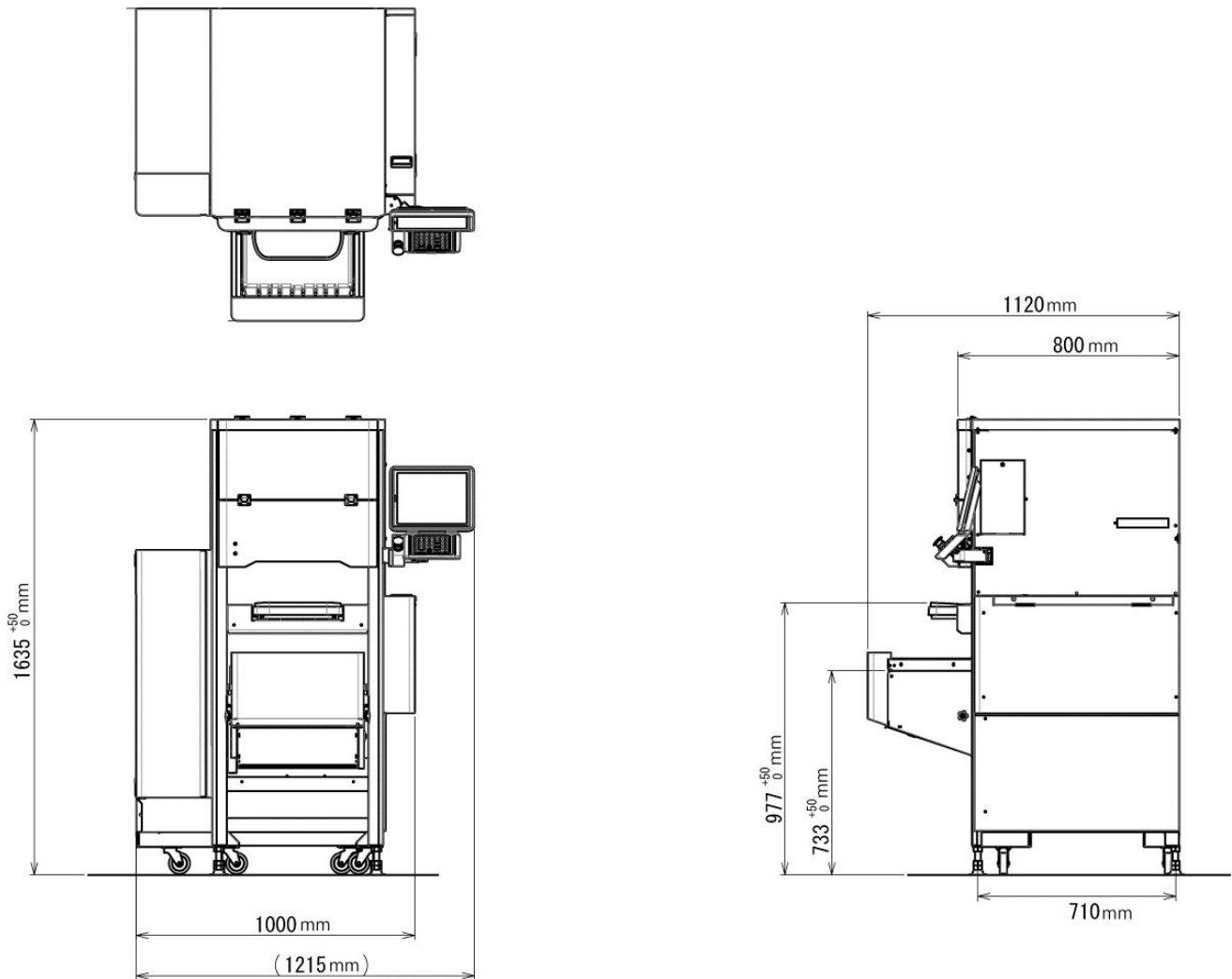

1.4.1.2 JR type external dimensions

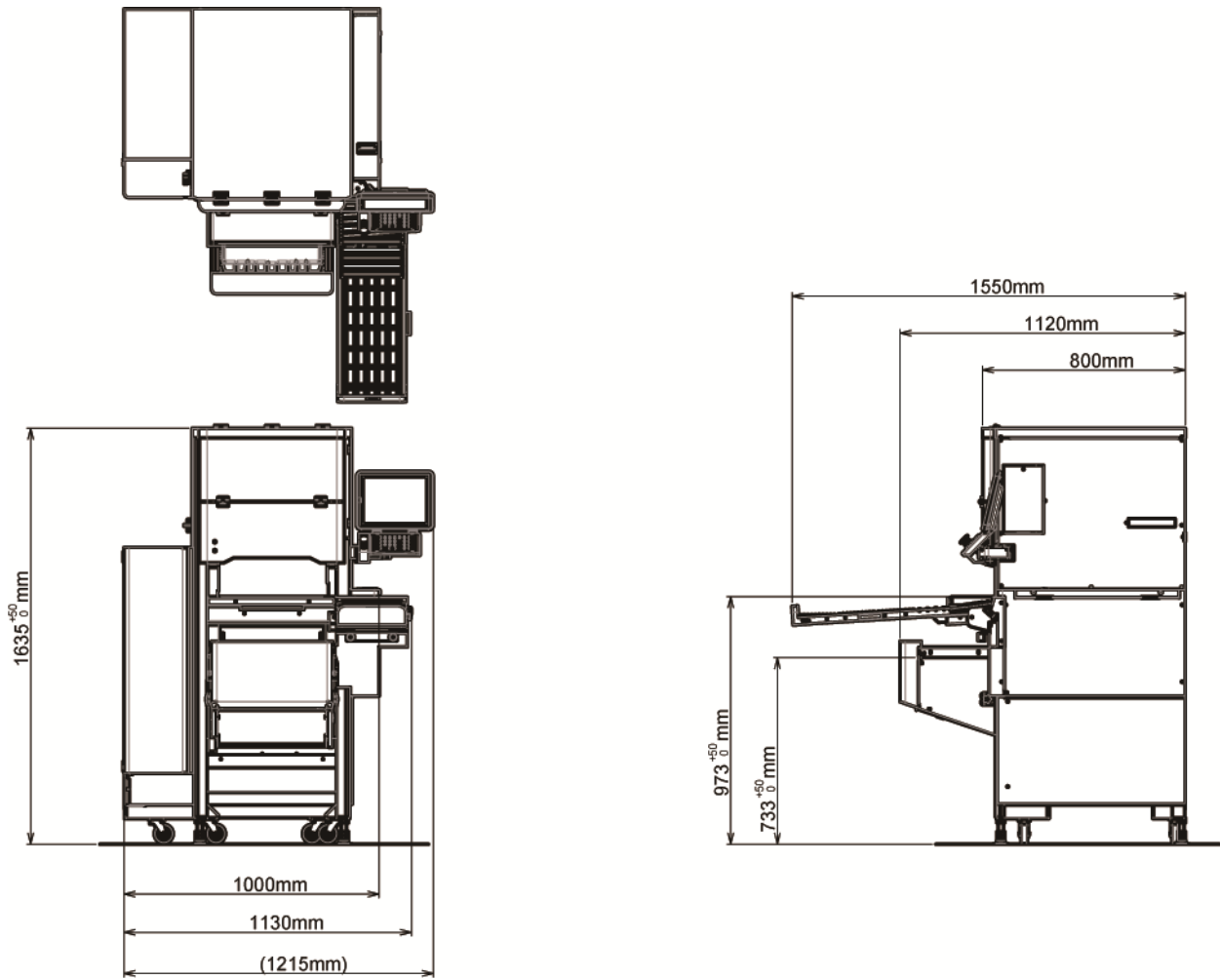

1.5 Package Content

1.5.1 Checking the Package Content

No.	Description	Check
1	BRUSH: CLEANING	<input type="checkbox"/>
2	CLEANER: THERMAL HEAD	<input type="checkbox"/>
3	PACK: UNI-PACK:	<input type="checkbox"/>
4	WEIGHT: CYLINDER:200 g	<input type="checkbox"/>
5	EXPLANATION: WEIGHT:	<input type="checkbox"/>
6	COVER TEN KEY AS:	<input type="checkbox"/>
7	WIRE:	<input type="checkbox"/>
8	WIRE:	<input type="checkbox"/>
9	ACCESSORY: BUSH: SKINTOP	<input type="checkbox"/>
10	ACCESSORY: LOCK NUT:	<input type="checkbox"/>

1.6 Items Required for Installation

1.6.1 Checking Tools for Installation

No.	Description	Check
1	Wrench (opposite side 30 mm)	<input type="checkbox"/>
2	Tools (tools a service person usually brings)	<input type="checkbox"/>
3	Weight	<input type="checkbox"/>

* It is convenient to use switch actuator (used to insert into each safety detection switch of covers or doors) when checking operations with 4 covers or doors open.

Model No.: 000-113-7261-** (Reference)

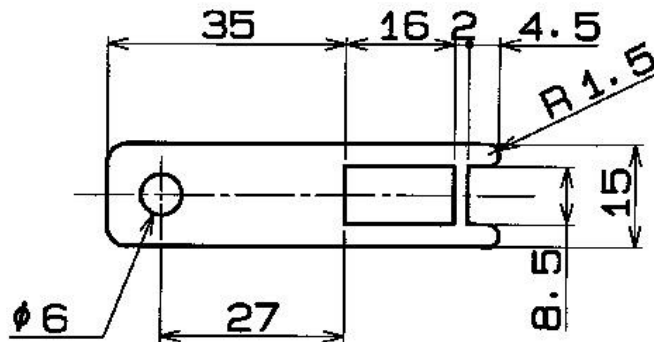

Dimension

1.6.2 Checking the Installation Environment

No.	Description	Check
1	In a place not subjected to direct sunlight.	<input type="checkbox"/>
2	In a place not subjected to exposure to water.	<input type="checkbox"/>
3	In a place with less dust and dirt.	<input type="checkbox"/>
4	In a place not subjected to floor vibrations.	<input type="checkbox"/>
5	Temperature: 5°C to 35°C	<input type="checkbox"/>
6	Humidity: 20 to 85% (No condensation)	<input type="checkbox"/>
7	In a place not subjected to fluctuations of power supply voltage.	<input type="checkbox"/>
8	In a place not subjected to direct cold air from an air conditioner etc.	<input type="checkbox"/>

1.6.3 Installation Space

- Allow ample installation space on either side of the machine to ensure easy access for maintenance.

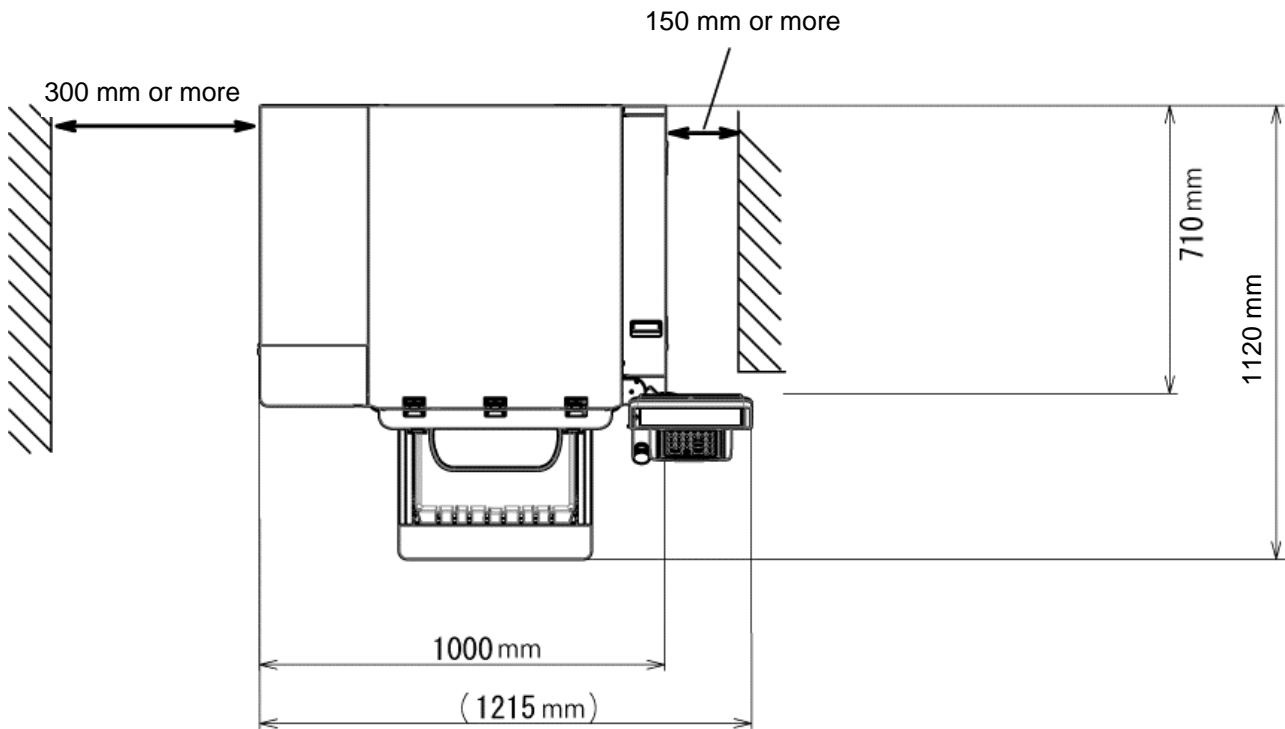

1.7 Power Supply

- The power supply for this machine is single phase 200 V AC 50/ 60 Hz, capacity 10 A (max. in normal operation). No need to change parts in accordance with the power supply frequency.
- Breaker must be installed in the building.

The built-in breaker for the main body is (Model No. NV-L22FYC 20 A 2P 100-200 V AC 30 MA) made by Mitsubishi. Overcurrent protection is 20 A, leakage current protection is 30 mA.

As current of 10 A is applied to this machine during wrapping, power-supply breaker enough capable of dealing with the current must be installed in the building.



As this machine is run by the switching operation using servo amplifier and servo motor, a high frequency component exists and a leakage current is bigger than most of usual commercial power supply. Considering the harmonic leakage, breaker corresponding to the high harmonic must be installed in the building.

- Apply D-class or better grounding (former 3rd-class grounding) to prevent electric shocks and malfunction.
- The power supply that generates noise and voltage drop may cause malfunction. Use the exclusive power supply



Electrical work must be performed by a qualified person.



To avoid an electric shock, the power supply must be connected to protective ground.

1.7.1 Cable length from terminal block to Skin top

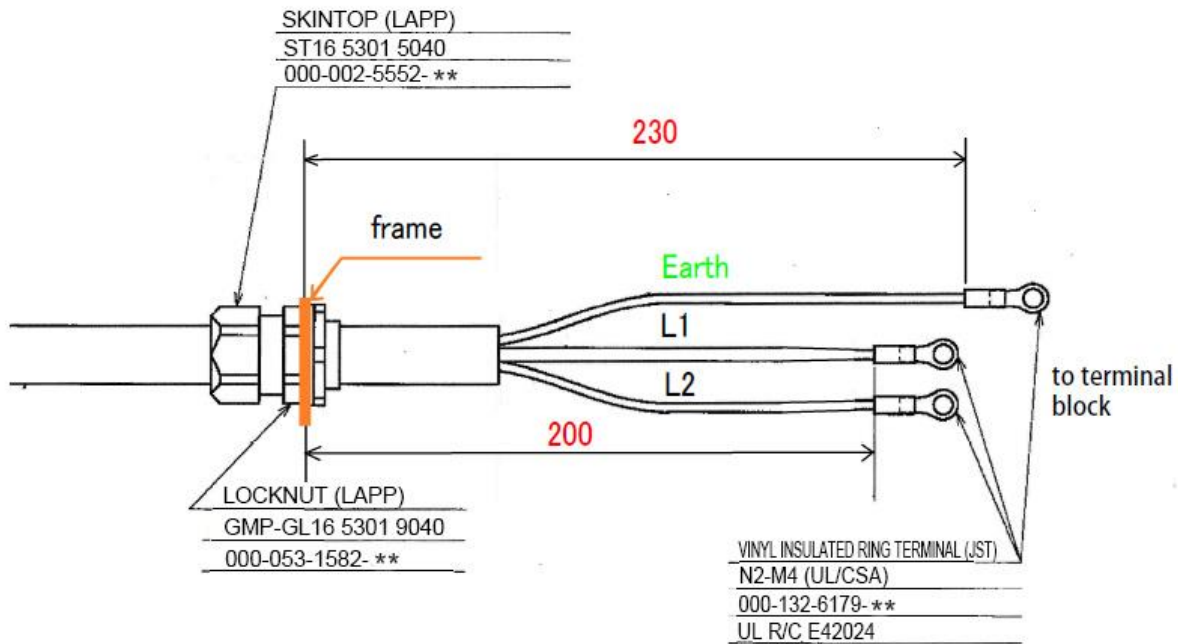
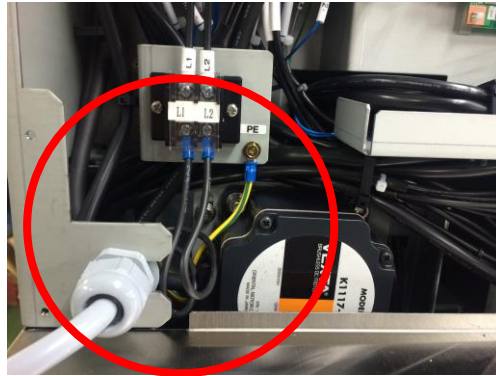

	Description	Remarks
1	The size of the AWG cable of the power supply cord connected to the client's facilities: AWG14	
2	The rated voltage of the cable of the power supply cord connected to the client's facilities: 600 V	
3	Stated that the screws with locking structure are used to mount PE of the power supply cord connected to the client's facilities.	The mounted screws should be used as the product has been shipped with SEMS screws mounted.
4	Stipulation of the length of the ground wire and live wire from Skintop of the power supply cable to the terminal block. (The ground wire needs to be longer than other wires.)	Length of the live wire cable (guideline): 200 mm Length of the ground wire (guideline): 230 mm Skintop of the following model number is included in the machine and shipped. Skintop: ST16 5301 5040 Locknut: GMP-GL16 5301 9040

1.8 Installation



When the passage route is too narrow to bring in the machine, detach the In-feed unit from the main body. Refer to *1.8.2 Detaching the In-feed Unit*.

As the minimum width of the machine main body is 787 mm without the In-feed unit, the installation site requires frontage of 787 mm or more.

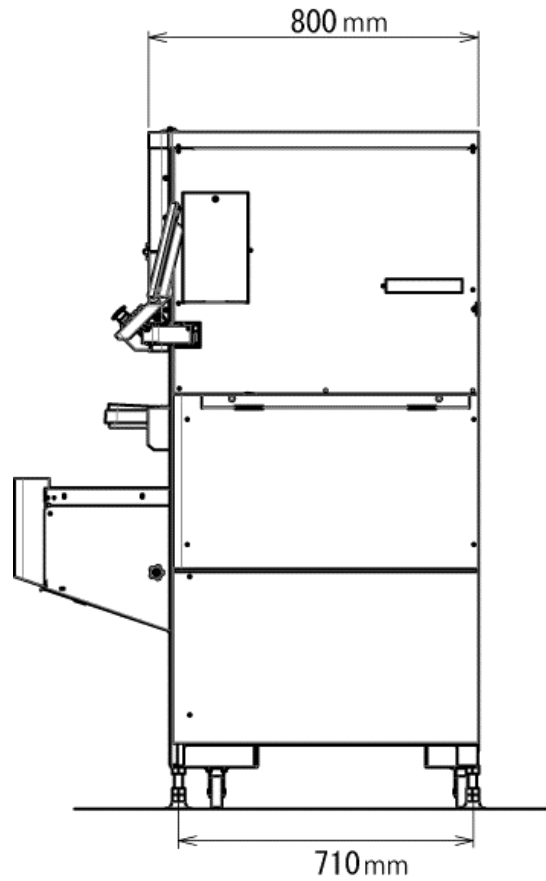

1.8.1 Checksheet (until the power supply is turned ON)

Procedure	Details	Check
1	Import WM-AI (total weight: WM-AI_ AT2 363kg) <ul style="list-style-type: none"> ▪ Assure the passage route ▪ Check the installation site and the strength of the floor along the passage route ▪ Caster diameter is 75mm 	<input type="checkbox"/>
2	<ul style="list-style-type: none"> ▪ Remove the air cap sheet that covers the exterior during transport 	<input type="checkbox"/>
3	Remove the following protective materials <ul style="list-style-type: none"> ▪ The rubber bands and cardboard from the feed unit ▪ The air cap sheet and cardboard from the operations unit ▪ The movable operations parts are secured in their shipping position, so remove the screws, insert into the other holes, and secure in the operations position 	<input type="checkbox"/>
4	Remove the secure packing materials <ul style="list-style-type: none"> ▪ Feeder unit securing cardboard ▪ Insertion plate securing cardboard ▪ Camera unit band ▪ Applicator left/right securing bands ▪ Applicator front/back securing cardboard 	<input type="checkbox"/>
5	<ul style="list-style-type: none"> ▪ Adjust the height of the 4 adjustment feet (jacks) so that the air bubble in the spirit level is positioned inside the circle (opposite sides of the spanner to be used: 30mm) 	<input type="checkbox"/>
6	<ul style="list-style-type: none"> ▪ Check the outlet voltage 	<input type="checkbox"/>
7	<ul style="list-style-type: none"> ▪ Mount any optional products 	<input type="checkbox"/>
8	<ul style="list-style-type: none"> ▪ Connect the power supply plug to the single-phase 200V AC outlet, and turn ON the power supply 	<input type="checkbox"/>



WARNING

If shipping again, mount the secure packing materials in the same way as for the original shipment.

1.8.2 Detaching the In-feed Unit

1.8.2.1 Detaching procedure

1. Open the In-feed unit covers to remove the five connectors.
2. Remove both sides of rail bolt with the hexagon whole M6 × 15, SW, PW.
As the infeed unit may drop when the bolts are completely removed, carefully remove the bolts while holding the infeed unit with your hand.
3. Remove the In-feed unit.
4. To attach the unit, perform the procedure in reverse order.



WARNING

In-feed unit weighs approximately 30 kg. Be fully ready before detaching the unit.



CAUTION

When connecting five connectors, make sure that connectors are securely and properly connected before applying the power.

1.8.3 Jack up

- 1) Adjust the horizontal using the spirit level AS for the scales.
- 2) Secure using the jack screws.



Tighten the red-framed nuts on the main unit while checking that the jack screws are firmly installed, and secure the 4 locations firmly.

- 3) Securely install the 4 jacks, and check that they do not rattle.

- Note:**
- If the jack screws are not secured firmly, machine vibration may retard weighing stability.
 - Raise the jack screw casters to a height where they can rotate freely.
 - Install the jack screws in a position where they do not contact the side groove lid, etc.
 - Be careful as the nut at the back left might not be closed.

1.9 SETUP

1.9.1 Items Required for Setup

- USB flash memory (It contains the user data)
- Weight (6 kg, corresponding to class 2 standard)

1.9.2 Checksheet

Procedure	Details	Check
1	<ul style="list-style-type: none"> • Checking the clock See the user manual Chapter 8 "Adjusting the Time and Date"	<input type="checkbox"/>
2	<ul style="list-style-type: none"> • Software version updates, peripheral app version updates 	<input type="checkbox"/>
3	<ul style="list-style-type: none"> • Measurements check 	<input type="checkbox"/>
4	Enter the license code and make the system settings	<input type="checkbox"/>
5	<ul style="list-style-type: none"> • Enter the master data 	<input type="checkbox"/>
6	<ul style="list-style-type: none"> • Make the I2NET or LAN settings 	<input type="checkbox"/>
7	<ul style="list-style-type: none"> • Set the film See the user manual Chapter 1 "Setting the Film"	<input type="checkbox"/>
8	<ul style="list-style-type: none"> • Age the film 	<input type="checkbox"/>
9	<ul style="list-style-type: none"> • Select the film type 	<input type="checkbox"/>
10	<ul style="list-style-type: none"> • Select the film width 	<input type="checkbox"/>
11	<ul style="list-style-type: none"> • Adjust the position at the front and back of the film roll (securing position) 	<input type="checkbox"/>
12	<ul style="list-style-type: none"> • Adjust the film roll brake 	<input type="checkbox"/>
13	<ul style="list-style-type: none"> • Adjust the spikes During shipping, the distance between the central pin spikes is set to 78.2 to 78.5mm. (The standard Ishida Wrap paper tube diameter is 76mm) Adjust the spikes if the force of the resistance when threading the spike is too great, or the paper tube slips during braking. See Chapter 2 "2.2.8. Wrapping Unit Adjusting ■Adjusting the Projection Amount of the Pin Spike"	<input type="checkbox"/>
14	<ul style="list-style-type: none"> • Adjust the film centering 	<input type="checkbox"/>
15	<ul style="list-style-type: none"> • Adjust the camera To improve detection accuracy, adjust the automatic recognition using the actual operating conditions. See Chapter 5 "5.16.2. Auto Recognition ■Adjustment Procedure"	<input type="checkbox"/>

Procedure	Details	Check
16	<ul style="list-style-type: none"> Adjust the sensors on the lift [Factory settings] Adjust the sensors using RISUPACK tray "GS 20-12C < Standard tray>" 200 x 120 x 20mm.  <p>If using the transparent tray and a plate tray at a height of 10mm, etc., adjust the sensor sensitivity. See Chapter 2 "2.2.7. Lift Unit ■About the adjustment of the sensor on the lift"</p>	<input type="checkbox"/>
17	<ul style="list-style-type: none"> Adjust the tray presser height 	<input type="checkbox"/>
18	<ul style="list-style-type: none"> Set the labels See the user manual Chapter 1 "Setting the Labels"	<input type="checkbox"/>
19	<ul style="list-style-type: none"> Adjust the printer [Factory settings] Specifications with mount: width 60mm, height from ground 37mm, gap 2.2mm If using a different label size from the factory default, make adjustments as described below <ol style="list-style-type: none"> Adjust the label guide width Adjust the distance of the label sensor hardware Adjust the guide roller position Adjust the label sensor sensitivity Adjust the label printing and peeling 	<input type="checkbox"/>
20	<ul style="list-style-type: none"> Adjust the suction 	<input type="checkbox"/>
21	<ul style="list-style-type: none"> Adjust the pasting position 	<input type="checkbox"/>
22	<ul style="list-style-type: none"> Tray registration and usage period 	<input type="checkbox"/>
23	<ul style="list-style-type: none"> Adjust the aggregate adding. Clear the aggregate 	<input type="checkbox"/>
24	<ul style="list-style-type: none"> Process the wiring 	<input type="checkbox"/>
25	<ul style="list-style-type: none"> Check the labels 	<input type="checkbox"/>

**WARNING**

Be sure to pull out the power plug from the outlet before detaching the In-feed unit and adjusting mechanism.

**CAUTION**

After turn off the power switch, pull out the power supply plug after one minute or more.

1.10 Upgrading the Program

1.10.1 Preparation

1. Create a folder named “Soft” on the root directory in the USB flash memory. To enter a name, either lowercase or uppercase character can be used because both characters are processed as the identical character.
2. Copy “AI software for upgrade” to “Soft” folder in the USB flash memory.



**Never turn off the machine while program is being copied.
Do not remove the USB flash memory during copying.**

1.10.2 Upgrading Software on the Main Machine

1. Select either “USB > MAIN (PRG + IMG)” or “USB > MAIN (ONLY PRG)”.
2. Select “SOFT” from a list of programs that shown on [MAIN] tab.
3. Touch [EXEC] button.
4. A confirmation message appears asking to download the program on the machine.
5. Upgrade the program by touching [EXEC] button.
6. When a progress status message appears, wait until copying is completed.
7. A confirmation message appears asking to restart the machine, remove the USB flash memory, and restart the machine.

1.10.3 Upgrading the Sub Application

1. Display [DOWNLOAD] screen of ADJUST mode again.
2. Display a list of sub applications by touching [SUB APP.] tab.
3. Select the latest software for the detector and wrapper. More than one program cannot be selected for the same sub equipment. The default setting of source copy program is [MAIN].
4. Touch [EXEC] button.
5. A confirmation message appears asking to download the sub equipment program.
6. Upgrade the program by touching [EXEC] button.
7. Check each software version by displaying [FIRMWARE DETAILS] button of ADJUST mode.

1.10.4 Adjusting the film spikes



1 Remove the holding bar.

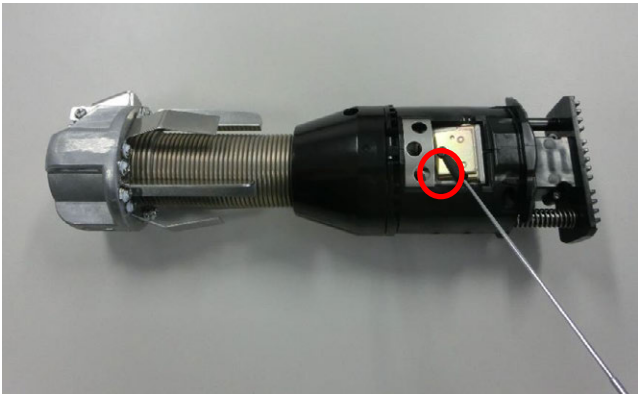

2 Turn the hexagon socket adjustment screw to adjust the projection amount of the "pin spike".



3 Adjust the projection amount of the pin spike at the center among three spikes to be 5 mm.

Note:

If the film roll is idling or over-tense, adjust the pin spike projection amount to the optimum tension for the film roll.

Adjust the pin spike projection amount based on the Ishida pure film roll.

4 When you have finished the adjustments, apply LOCTITE to the adjustment screws.

1.10.5 Adjusting the position at the front and back of the film roll (securing position)

After repeating the film feed several times, adjust the film roll set position so that the film edge is inside that of the cutter blade. Change the position of the shaft holder roll of the holding bar.



1. Insert the holding bar into the shaft according to the orientation.

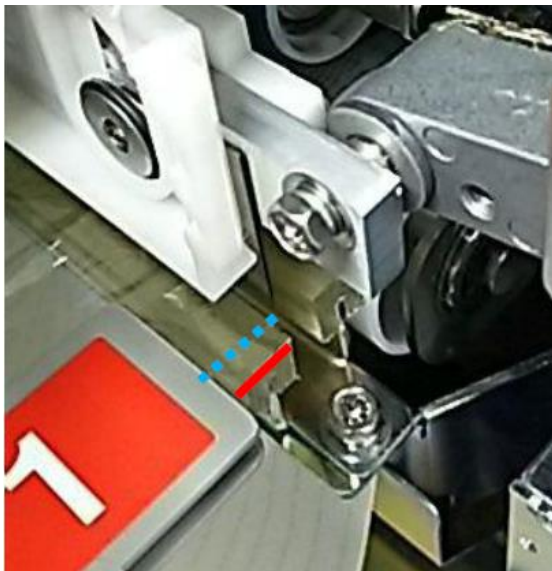

2. There is a difference in the cutter cradle and the cutter blade as shown in the diagram above. Check that the film edge is further inside than the cutter blade (i.e., than the blue dotted line). As a benchmark, check that the film does not protrude from the resin plate on the cutter unit.
If the film is protruding, move to the next step to make adjustments.

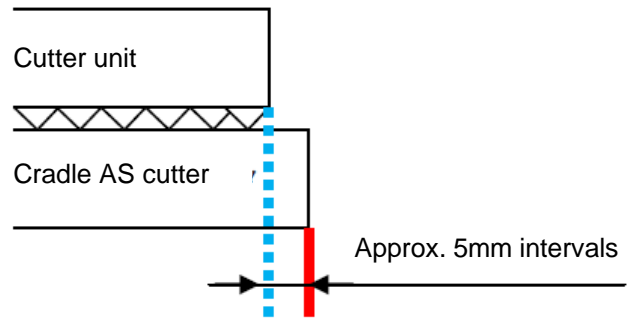

3. Adjust the position of the screw holes on the film holding bar in 5mm units. After adjustment, make sure to coat the screws in this location with LOCTITE to assure their tightening torque.

Note:
During shipping from the factory, the shaft tip is mounted to a position 6mm from the folder AS.

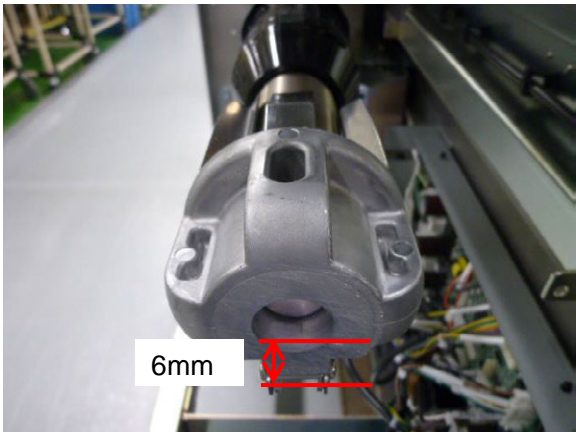

1.10.6 Setting the film roll brake

- Note:** Failure to make adjustments may cause the following nonconformances.
- If there is little film remaining, the film may not reach to the right (I.e., the film skews to the left without being able to left/right center)
 - Film feed fails
 - Wrinkling occurs easily during wrapping

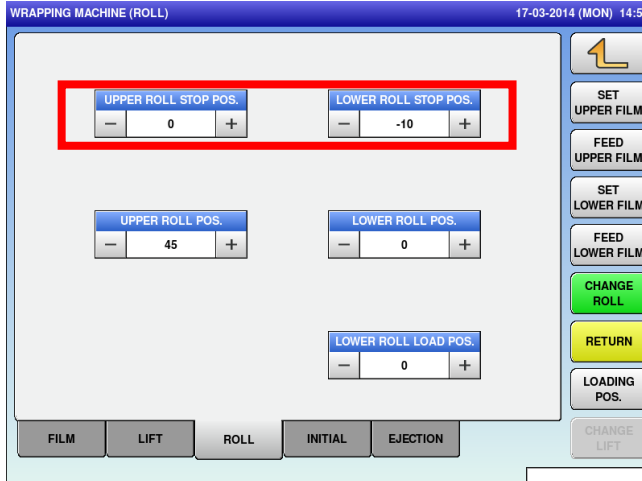

The factory defaults for the upper and lower roll stop positions are "0", so set the new film to be used by the user, and adjust the film roll stop positions.

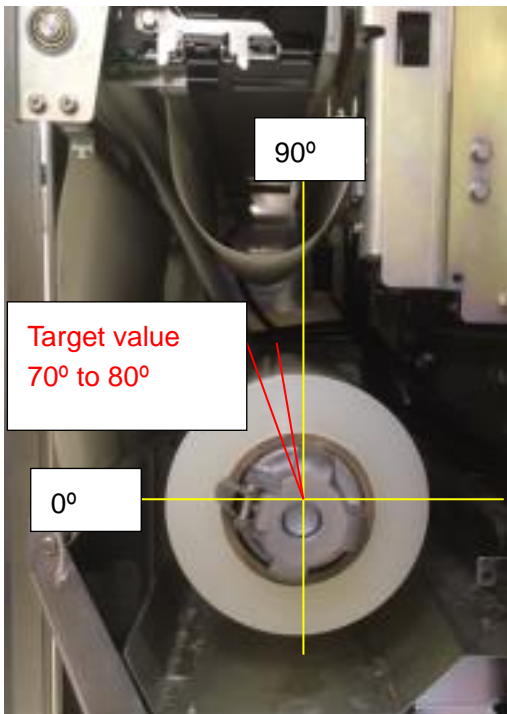

The initial feed of the film after loading has no information on the film roll diameter during the previous wrapping (remaining amount of film), so to ensure a stable feed, the feed speed is slow. At this time, the remaining amount of film is detected by the encoder mounted to the back. Feed the new film 4 or 5 times before checking the roll stop values (film peeling position).

If the condition after 4 or 5 feeds is all within the red lines in the adjacent photo, everything is normal.

If the film width is short, the inertia during film roll movement is small, so the brake settings are often negative values. Conversely, if the film width is long, the inertia during film roll movement is great, so the brake settings are often positive values.

If the peeling position exceeds 80° and the film diameter is great (the film is nearly new), the film will tear easily and the feed fail.

If the peeling position is less than 70° and the film diameter is small (there is little film remaining), the film will not reach to the right, the film feed will fail, and the film will wrinkle easily. (E.g.: The film will catch on the feeder and become stretched, then shrink when cut and not adhere to the cradle, so the next feed will fail.)

Adjust the film centering: adjust the film length.

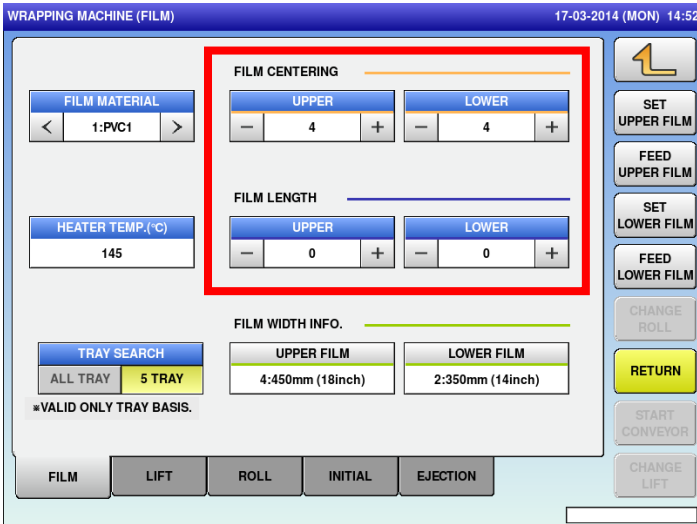

Adjust the film centering: to adjust the film length, the default adjustment values have been entered. Depending on the film, the stop position will vary greatly, so check and adjust again.

Adjust the film centering: to adjust the film length, the default adjustment values have been entered. Depending on the film, the stop position will vary greatly, so check and adjust again.

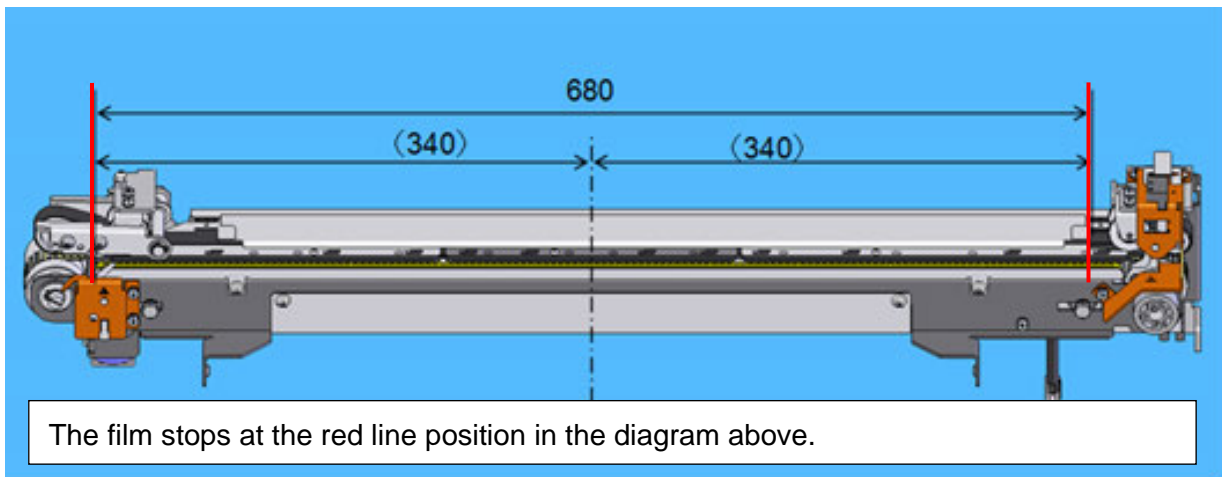

Left side: Adjust so that the film edge reaches the left edge of the yellow rubber (under the clamp).

Right side: Check the locations with the red arrows, and adjust so that the film edge is directly under the cover edge (yellow dotted line).

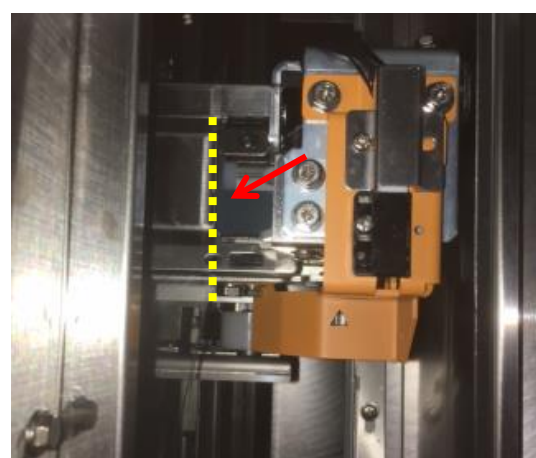

Even is the machine status is normal the film stop position varies approx. ± 1 cm.

1.10.7 Camera adjustments

To improve the camera detection accuracy, implement automatic recognition adjustment under the following environment.

- Close all the wrapping machine covers
- Making adjustments with the cover under the camera removed may disable auto adjustments
- Implement after jacking up at the installation site
- Implement using the same level of lighting as during actual operations
- After recovery, return the centering conveyor and feed bar to their home positions.

1.10.7.1 Settings procedure

1. Gently press down on the extruder (camera) so that the camera makes firm contact with the frame.

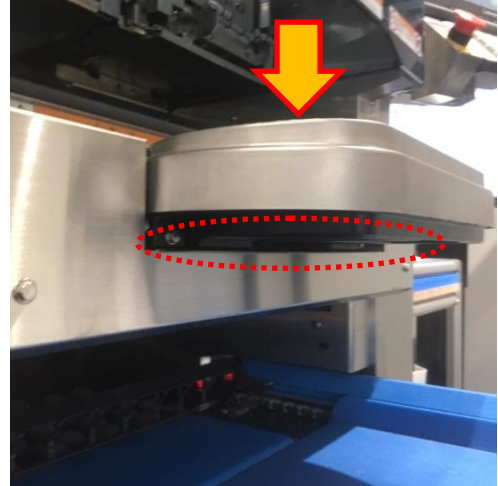

2. Implement auto adjustment (brightness).
3. Implement auto adjustment (distortion).

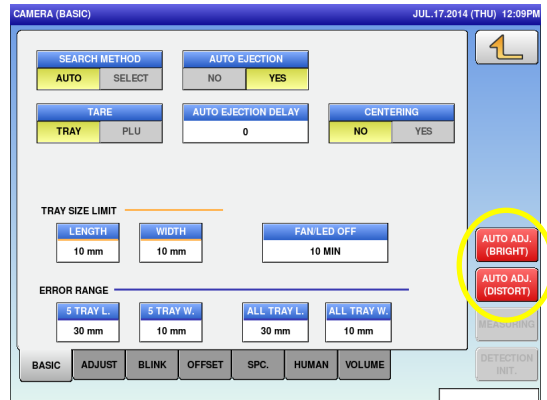

- If the auto adjustments in steps 2 and 3 fail, implement full initialization of the detector (i.e., set the camera gain and threshold value to 0, and then press the detection initialization button), and make the settings from step 2 again.

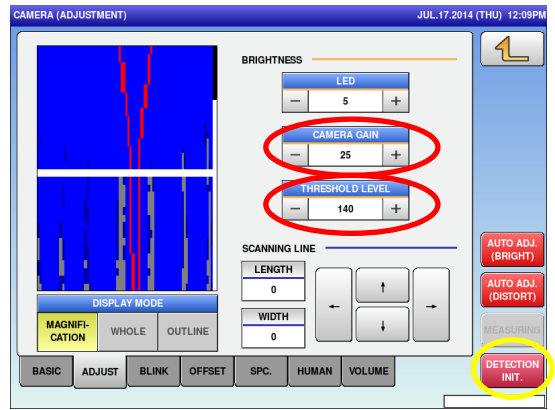

- Place the tray on the scale, and press the measurement button. Wait 10s, and then check the flicker width value. If the tray width is "12mm" or less, and the tray depth is "6mm" or less, the tray can be detected. If these values are exceeded, register the tray using the no tray detection and no centering settings.

Note:

Compensating to enable trays that are difficult to detect be detected increases the possibility of the misdetection of dirt on the scale, etc.

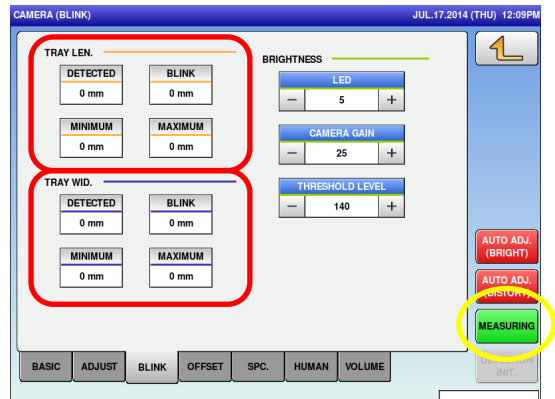
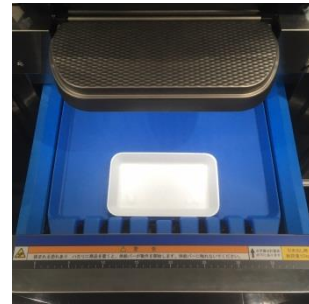

- Click the auto adjustment (scale height) button.

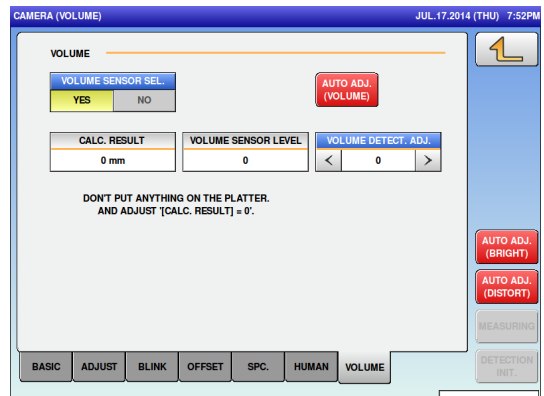

To make further adjustments, see Chapter 5 "5.16. Auto Adjustments"

1.10.8 Tray presser height adjustments

The default tray adjustment is a height of 25mm. To use trays below that, adjust the height. (The recommended value is a height that presses low-backed trays approx. 5mm)

*Adjustments are unnecessary if using only trays with a height of 25mm or greater.

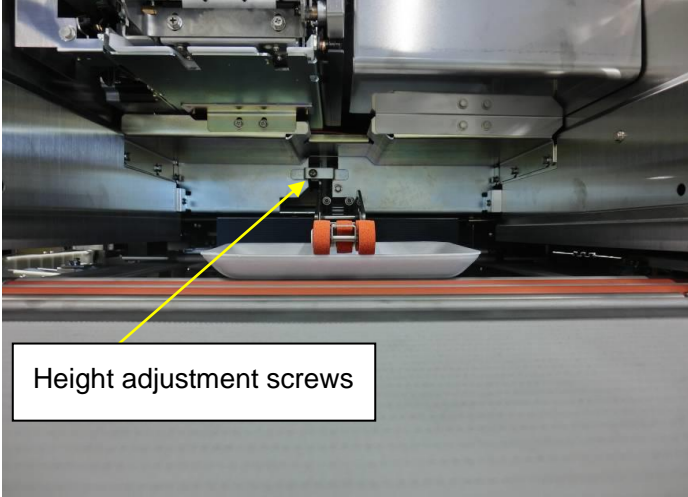

1.10.9 Printer adjustments

The diagram below shows the relevant parts. For adjustments and changes, see "Chapter 2. Mechanical Adjustments".

Set the format and issue patterns before making adjustments. (Enter the master using file I/O.)

1) Adjust the label guide width

The default is set to use labels with a 60mm width. (If using a mount, the mount width setting is 62mm.) Adjust the width if using any other labels.

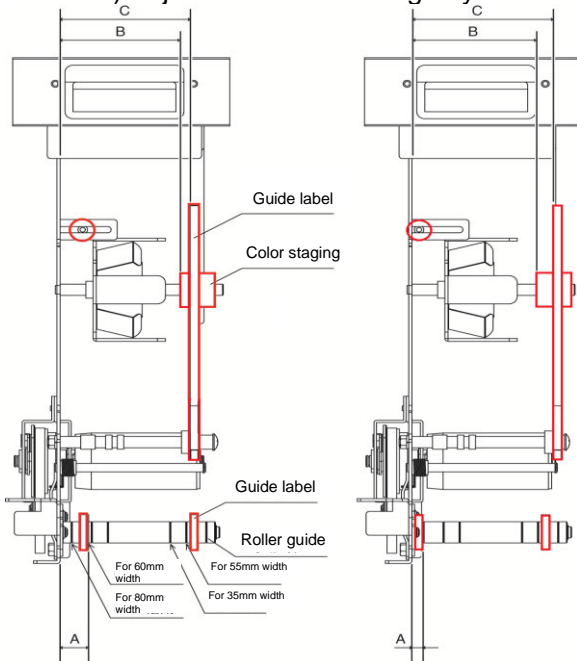

Label width 35mm to 70mm; label width 71mm to 80mm

2) Adjust the label sensor distance hardware

If the label gap stop position is under the label sensor after the label has been fed, adjust the label sensor position.

(If the gap stop position is poor, there is an increased possibility of a label end error or label size error occurring.)

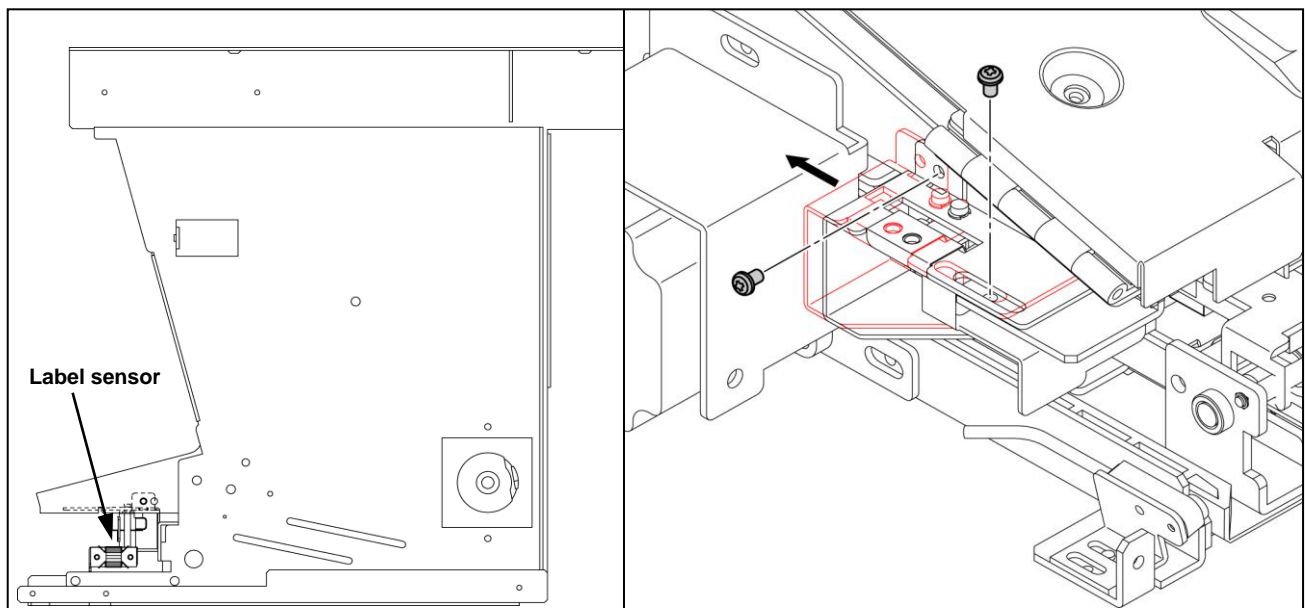

- 3) Guide roller suppression bracket position
 Adjust the guide roller position to reduce the impact of peculiar label winding due to the guide roller.
 Check the status immediately after idling.

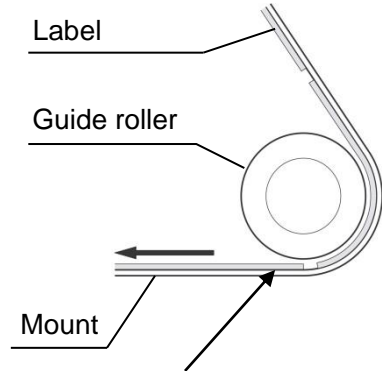
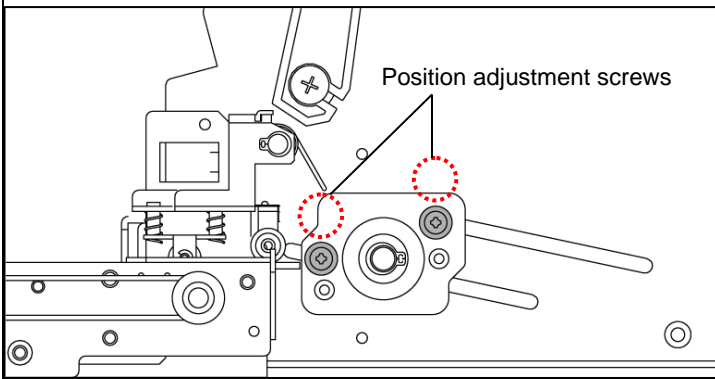

Make sure the back is straight to prevent peculiar winding occurring to the back of the label.

- 4) Adjust the label sensor sensitivity
 Adjust using the advanced settings screen of the paper feed tab in printer adjustment mode.

Increase the label sensor sensitivity so that the difference between the highest flat location and the cam is 100 min. Further, make sure the cam is 255 max.

If the rattle of the flat parts is great, enter a label sensor threshold value.

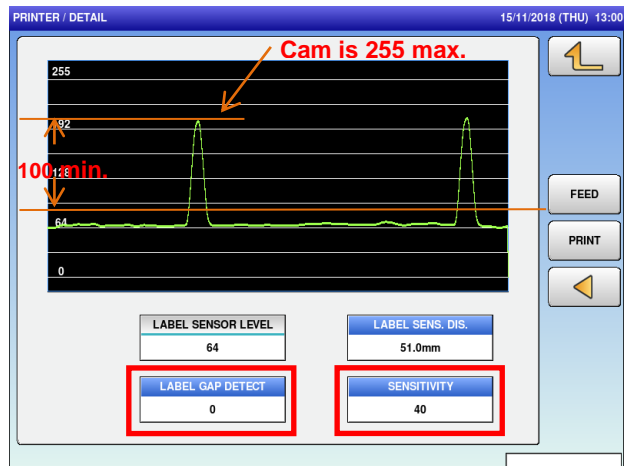

- 5) Roller distribution (interval) changes to the label wait roller



- 6) Position and height before and after the label wait roller



7) Adjust label printing and peeling
 Basically, implement the following procedure.

- ① Enter the actual gap size
- ② Enter the lead amount
 Regular printer: 9.5mm - gap
 POP printer: 11.0mm - gap
- ③ Enter the lead stop amount
 Regular printer: lead amount -3 to 3.5
 POP printer: lead amount -4
- ④ Label sensor distance settings (The label sensor distance is set before shipping)
 Adjust the label line distance values so that during printing, the distance between the horizontal line at the bottom of the label and the lower edge of the label have the same values as the lead amounts.
 Increasing the label sensor distance raises the height of the printing.

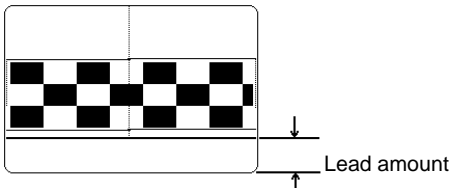

- ⑤ Visually check the peeling
 Changing to 2-step issue (to check the operations) and press the Print key to issue the 1st step. (I.e., issue to the suction preparation position.) Next, press the Call key to issue the complete peeling. (I.e., issue to the actual suction position.) Check that in this condition the label is completely removed from the mount.
 If the issue amount is insufficient and peeling is poor, add +1mm to the lead amount to cause complete peeling.

8) Recheck items 1 to 7.
 Changing the gap amount, lead stop position, and label sensor distance changes the label stop position. Consequently, it may be necessary to readjust items 2 and 3.

1.10.10 Applicator adjustments

The suction position adjustments are set before shipping, but if suction fails, adjust as described below.

If labels remain in the wait roller

Adjustment details	Advantages	Disadvantages
Increase the height of the wait roller unit	Peeling improves	The labels rise to make contact with the applicator immediately before suction easier
Lower the application suction position to 0.5mm below the wait roller ring	Factory default standard position Peeling improves	Stronger adhesion to the wait roller
Lower the application suction position to 1mm below the wait roller ring	There is no pressure on the wait roller, so adhesion to the wait roller is weak	Peeling worsens
Increase the PRE-STOP POS. 1 to 2mm	Peeling improves	Label can easily fall off before suction
Increase the FEED LENGTH 1mm	Peeling improves	Increasing the lead amount too much improves adhesion as the label can be wound up and pressed onto the wait roller without peeling
Enter 10 in the EDGH OUT DELAY	Peeling improves	Performance falls

If the label peels back and the label back contact the applicator

Adjustment details	Advantages	Disadvantages
Lower the wait roller	The label lowers	Peeling worsens
Review the position of the printer unit guide roller	The peeling back position changes The peeling back angle changes	—

After adjustment, use the continuous operations tab to apply 50 labels each at 0° to -90°, and check that no suction errors occur, and that the mounting position is not greatly misaligned.

Use the position tab to check the adhesion at 0° to -90°, and check that adhesion is close to the following standard positions.

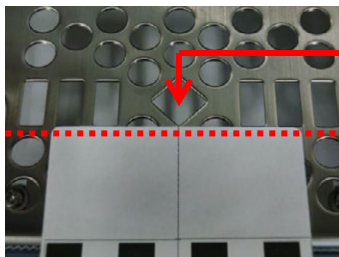

The label center line is positioned at the apex under the ◊

The upper edge of the label is the same as the underside of the rectangle

0° mounting

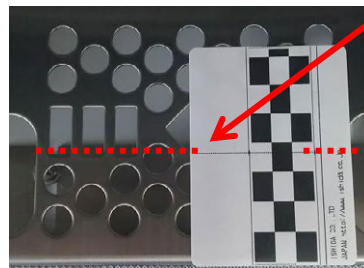

The label center line is positioned at the apex under the ◊

The label center line is the same as for the underside of the rectangle

-90° mounting

- Note:**
- The labeling position misaligns slightly with each labeling, so it is not possible to label as accurately as the position in the photo every time. Consider this misalignment when making adjustments.
 - If changing the labeling controls, change the tray height standards using the initialization tab.

1.10.11 Operation Check

1.10.17.1 Label printing check

Check the print with the labels actually used by the user.

1.10.17.2 Wrapping machine check

Check the wrapping with the trays used by the user.

1.10.12 Instruction Manual

Based on the instruction manual, provide explanations on operation method and handling precautions to the user. Make sure that the user fully understands the points.

1.10.13 Warranty Card

Fill in the warranty card and provide it to the user.

1.10.14 Setups

Setup is performed on the maintenance screens of Setup Mode and Adjust Mode that are authorized with login.



For each operation, refer to **Chapter 4 Setup Mode** and **Chapter 5 Adjust Mode**.

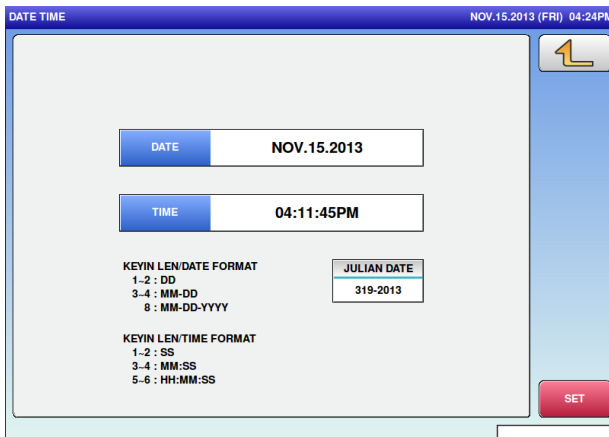

Screen 1: Date Time

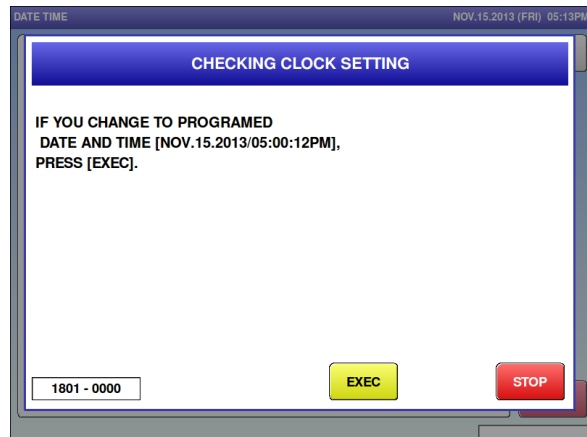

Screen 2: Checking Clock Setting

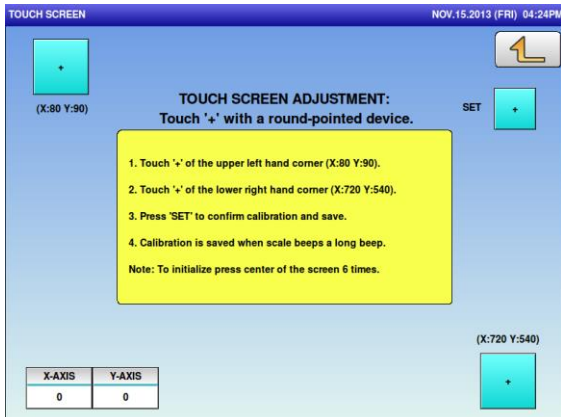

Screen 3: Touch Screen

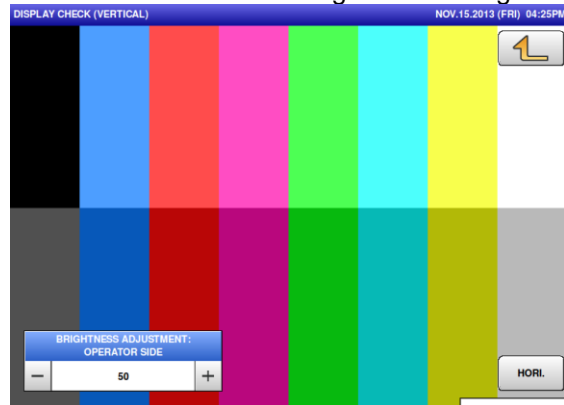

Screen 4: Display Check (vertical)

- The following setup is performed on the maintenance screens of Setup Mode and Adjust Mode.
- To display maintenance menu screens, enter "495344" using numerical keys, and press [LOGIN] button on the screen.

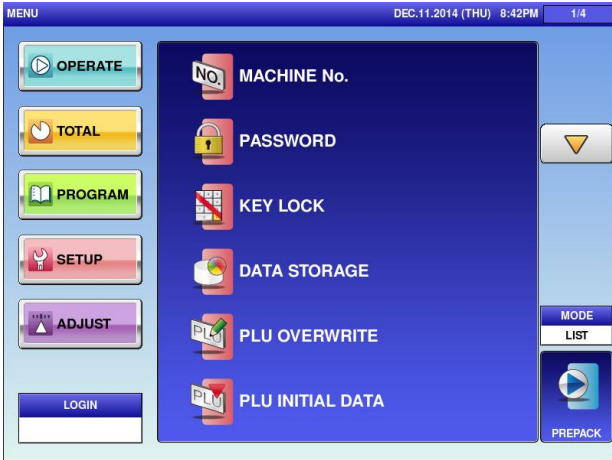

Screen 5: "SETUP mode" after logging in (1/2)



Screen 6: "SETUP mode" after logging in (2/2)



Screen 7: "ADJUST mode" after logging in (1/2)

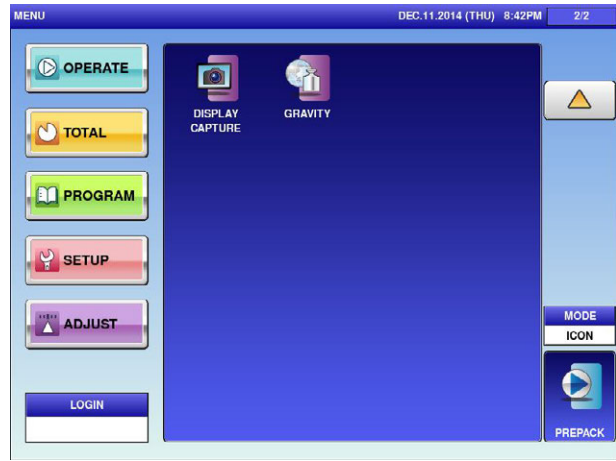

Screen 8: "ADJUST mode" after logging in (2/2)

1) Mandatory items to be adjusted

- MEMORY CLEAR (Adjust Mode)..... See screen 9.
- PRINTER (Adjust Mode)..... See screen 10 to 13.
- WRAPPING MACHINE (Adjust Mode)..... See screen 14 to 18.
- CAMERA (Adjust Mode)..... See screen 19 to 25, or *Chapter 2 “2.1.4 Camera Unit”*.
- PLU INITIAL DATA (Setup Mode)..... See screen 26 to 32.
- LABEL COMB. (Setup Mode)..... See screen 33, 34.
- LABEL FORMAT (Setup Mode)..... See screen 35.
- ERROR PROCESS (Setup Mode) See screen 36 to 38.

Items required to be adjusted on screen

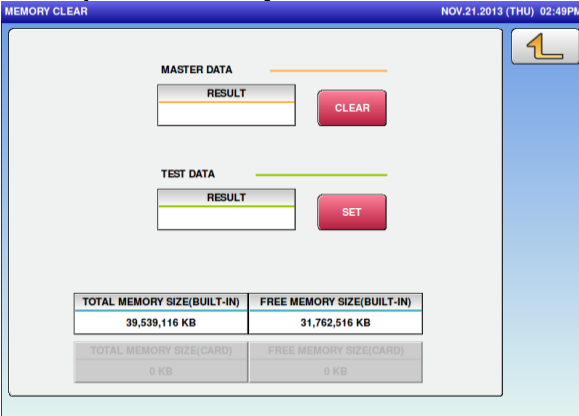

Screen 9: MEMORY CLEAR

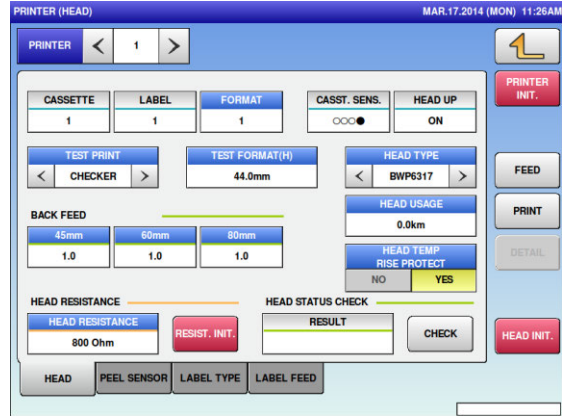

Screen 10: PRINTER (HEAD)

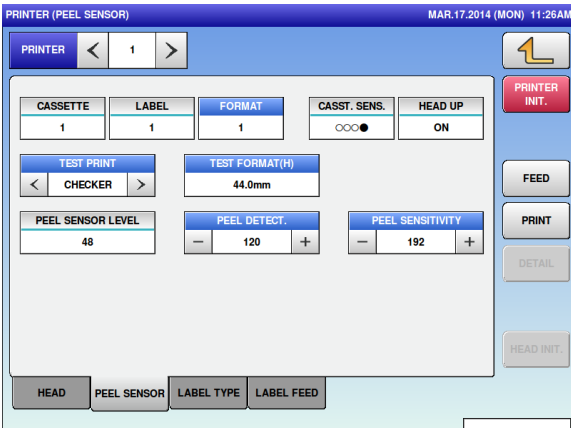

Screen 11: PRINTER (PEEL SENSOR)

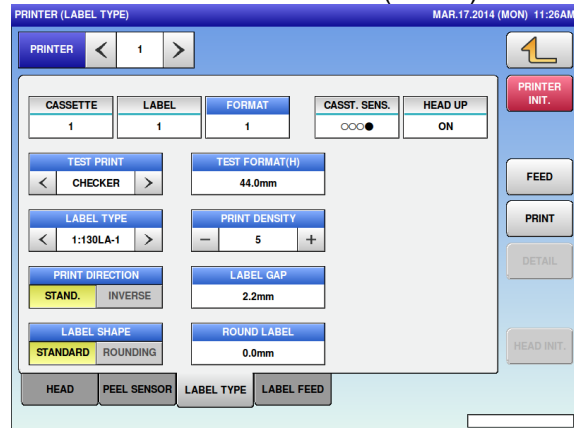

Screen 12: PRINTER (LABEL TYPE)

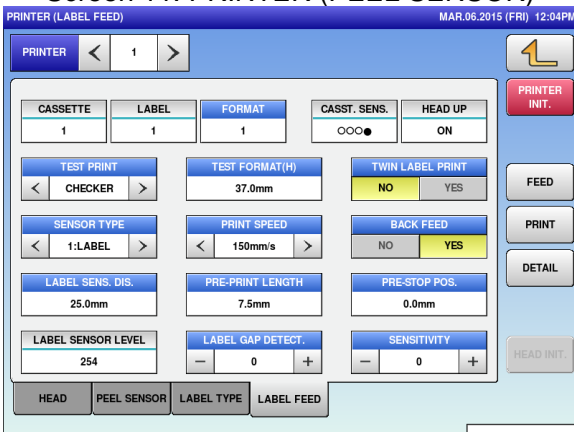

Screen 13: PRINTER (LABEL FEED)

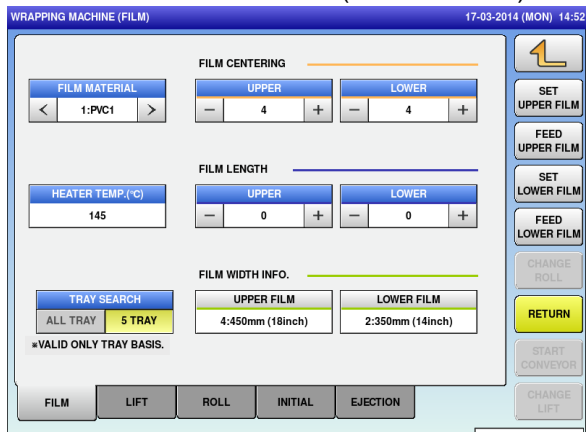

Screen 14: WRAPPING MACHINE (FILM)

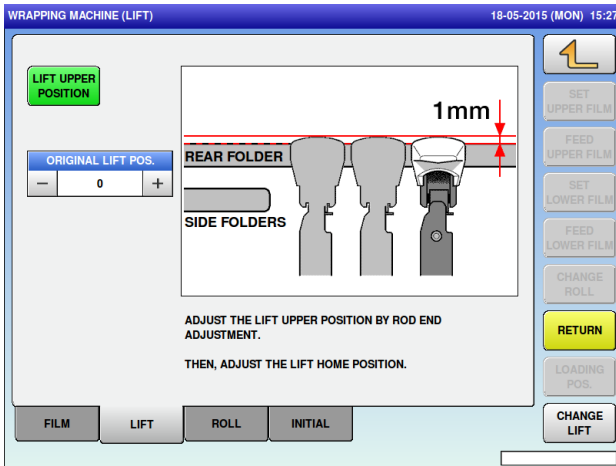

Screen 15: WRAPPING MACHINE (LIFT)

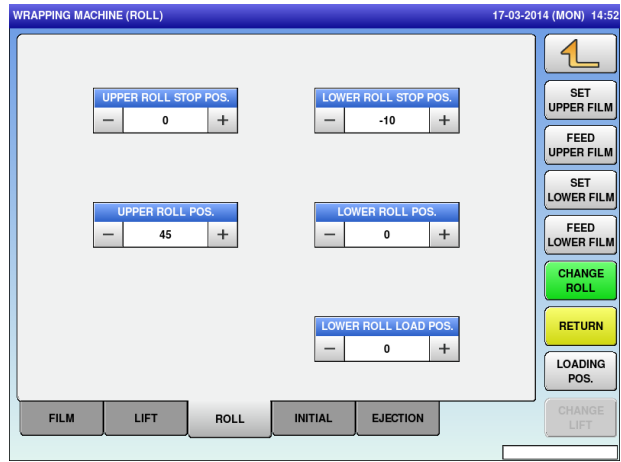

Screen 16: WRAPPING MACHINE (ROLL)

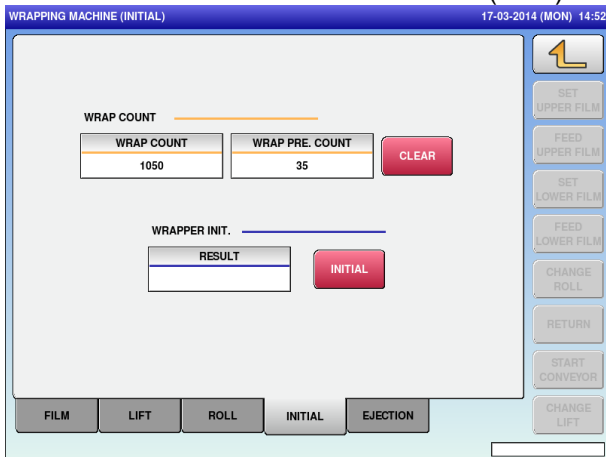

Screen 17: WRAPPING MACHINE (INITIAL)

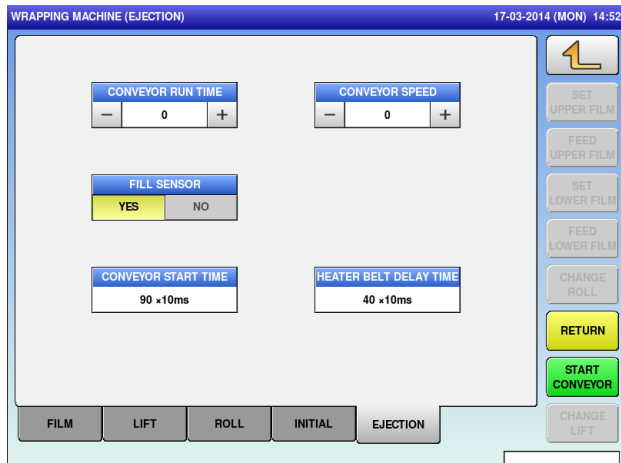

Screen 18: WRAPPING MACHINE (EJECTION)

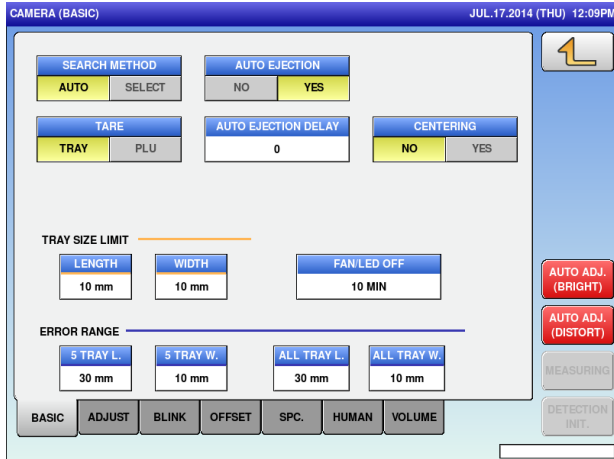

Screen 19: CAMERA (BASIC)

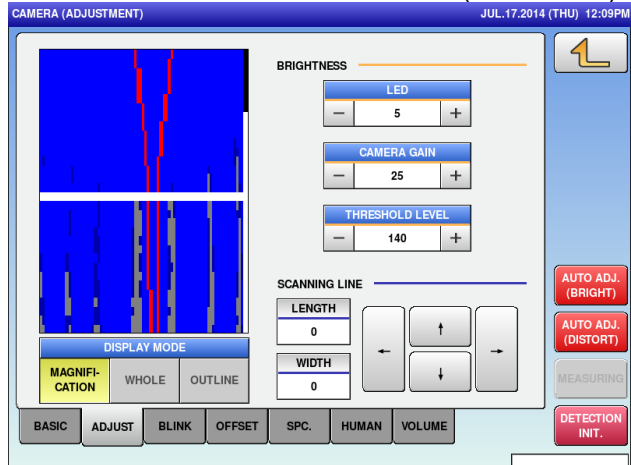

Screen 20: CAMERA (ADJUSTMENT)

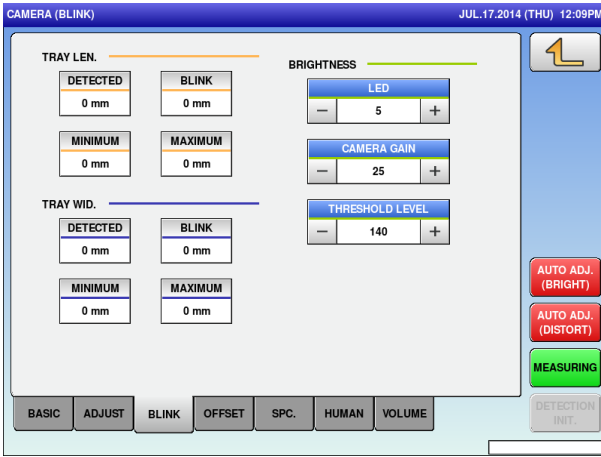

Screen 21: CAMERA (BLINK)

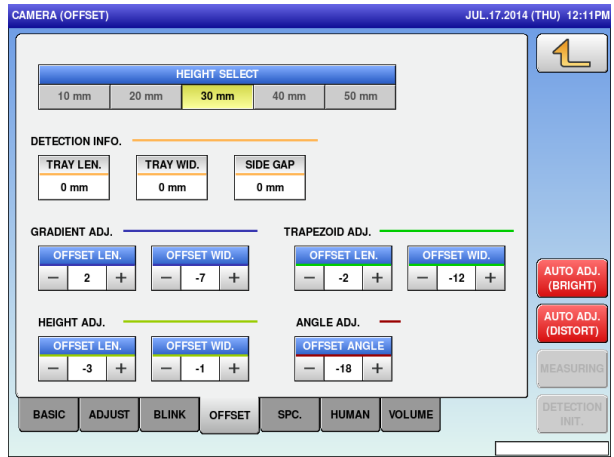

Screen 22: CAMERA (OFFSET)

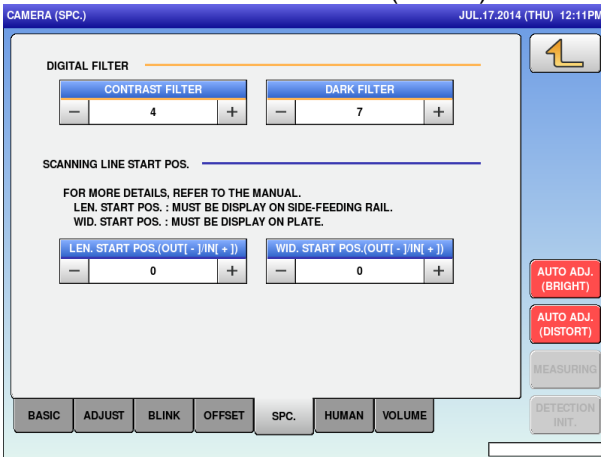

Screen 23: CAMERA (SPC.)

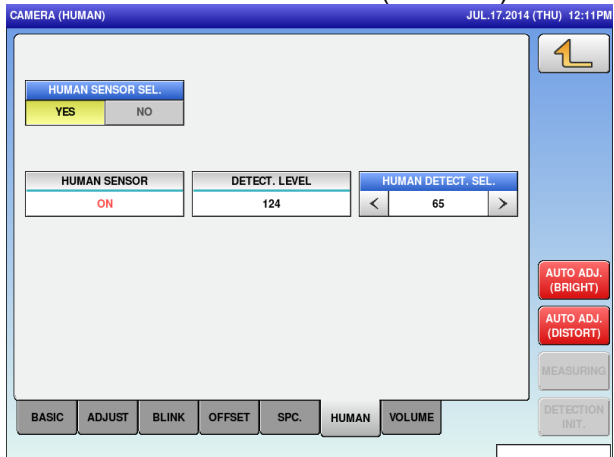

Screen 24: CAMERA (HUMAN)

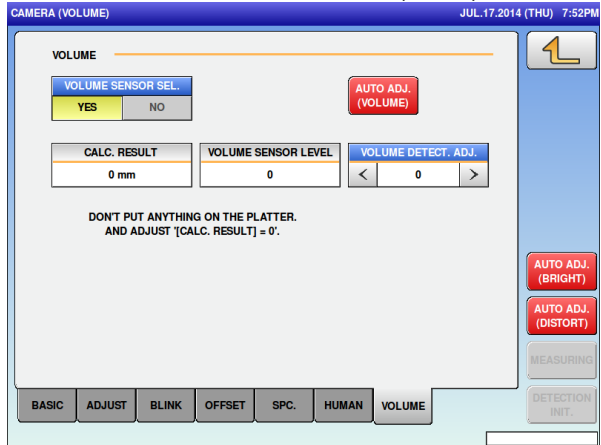

Screen 25: CAMERA (VOLUME)

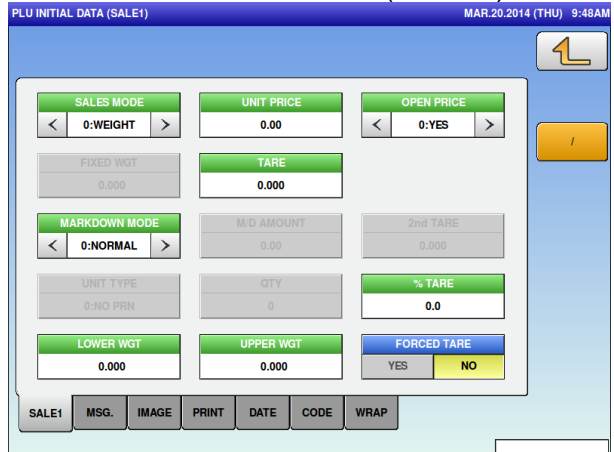

Screen 26: PLU INITIAL DATA (SALE1)

PLU INITIAL DATA (MSG.) MAR.20.2014 (THU) 9:49AM 1/3

NUTRITION	0	NONE
EXTRA MSG.1	0	NONE
INGREDIENT	0	NONE
EXTRA MSG.3	0	NONE
COUPON MSG.	0	NONE
POP MSG.	0	NONE
COOKING TIME	0	NONE
FREE MSG.1	0	NONE

SALE1 MSG. IMAGE PRINT DATE CODE WRAP

Screen 27: PLU INITIAL DATA (MSG.)

PLU INITIAL DATA (IMAGE) MAR.20.2014 (THU) 9:49AM

IMAGE 1 0 IMAGE 2 0

IMAGE 3 0

SH. IMAGE 0

SAFE HANDLING IMAGE
NO PRINT PRINT

SALE1 MSG. IMAGE PRINT DATE CODE WRAP

Screen 28: PLU INITIAL DATA (IMAGE)

PLU INITIAL DATA (PRINT) 05-04-2014 (SAT) 13:42

1st LABEL ATTACH TYPE < 0:REFER > 2nd LABEL TYPE < 1:NO > 1st LABEL BAR PRINT < 1:YES >

1st LABEL FORMAT No. 0 2nd LABEL FORMAT No. 0

PRINT MODE < 1:YES > 1st LABEL PRINT < 1:YES > 2nd LABEL PRINT < 1:YES >

SUB LABEL PRINT < 1:YES > EYECATCH LABEL PRINT < 1:YES >

SALE1 MSG. IMAGE PRINT DATE CODE WRAP

Screen 29: PLU INITIAL DATA (PRINT)

PLU INITIAL DATA (DATE) MAR.20.2014 (THU) 9:49AM

PACK DATE PRINT YES NO PACK TIME PRINT < 0:NO PRINT > PACK TIME DATA

SB DATE PRINT YES NO SB TIME PRINT < 0:NO PRINT > SB TIME DATA 0 MIN.(S) AFTER

SHELF LIFE(days) NEXT DAY(1 day) USE BY DATE PRINT YES NO UG DATE DATA

DATE CAL YES NO

SALE1 MSG. IMAGE PRINT DATE CODE WRAP

Screen 30: PLU INITIAL DATA (DATE)

PLU INITIAL DATA (CODE) MAR.20.2014 (THU) 9:49AM

ITEMCODE 00000000 REG. CODE 0 POS FLAG 02

BARCODE 0000000000000000 POS REFERENCE < 0:REFER > BARCODE TYPE 0:REFER

POS FORMAT (WGT) REFER TRACE ENABLE YES NO

DEPARTMENT 0 GROUP 00

SALE1 MSG. IMAGE PRINT DATE CODE WRAP

Screen 31: PLU INITIAL DATA (CODE)

PLU INITIAL DATA (WRAP) MAR.20.2014 (THU) 10:56AM

TRAY No. 0 WRAP MODE < 1:WRAP+LABEL > VOLUME < 0:NONE >

PASTE MODE < 1:AUTO > DIRECTION 0:NORM. PASTE < 0:NORM. PASTE > TRAY VOL. DETECT. < 1:AUTO >

FEED SPEED < 0:TRAY REF. > WRAP SPEED < 0:TRAY REF. > TRAY AUTO DETECT. < 2:YES >

METAL DETECT. No. 0 IX RESEVATION No. 0 TRAY CENTERING < 0:YES >

SALE1 MSG. IMAGE PRINT DATE CODE WRAP

Screen 32: PLU INITIAL DATA (WRAP)

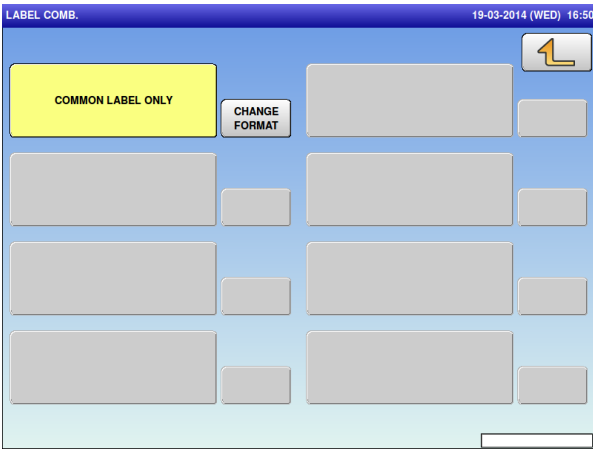

Screen 33: LABEL COMB.

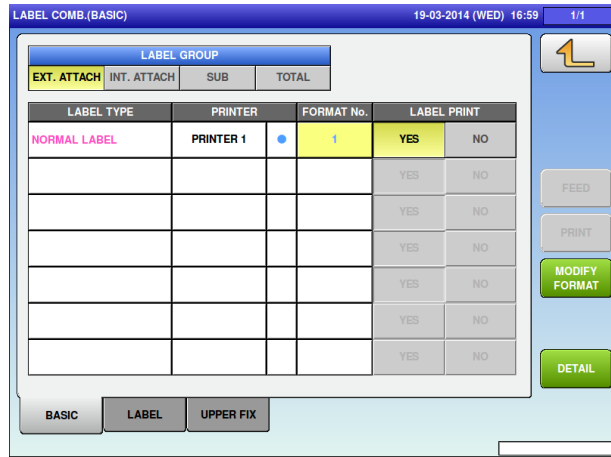

Screen 34: LABEL COMB. (BASIC)

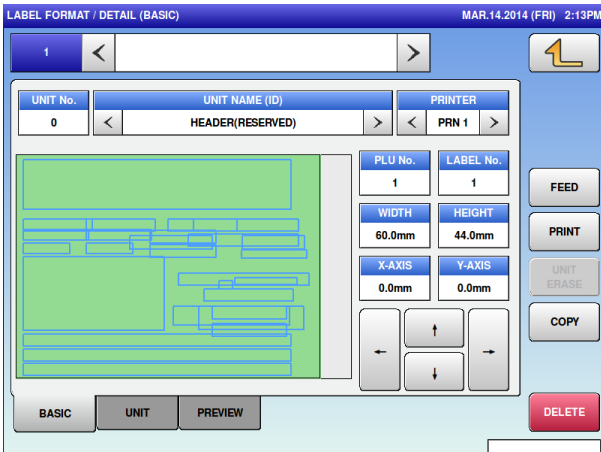

Screen 35: LABEL FORMAT (BASIC)

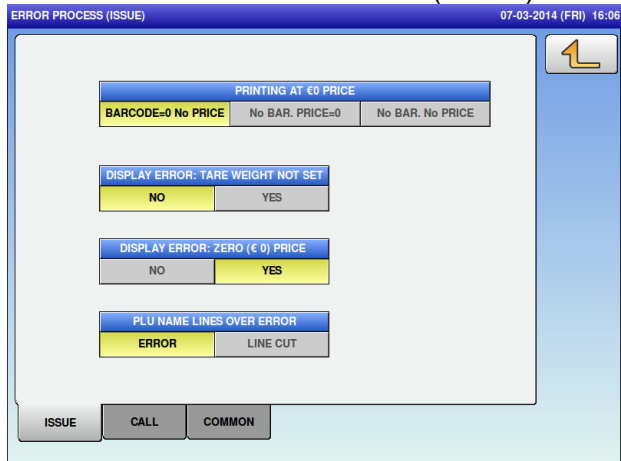

Screen 36: ERROR PROCESS (ISSUE)

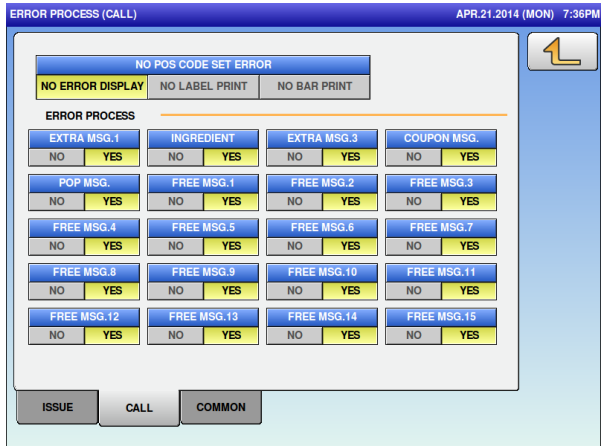

Screen 37: ERROR PROCESS (CALL)

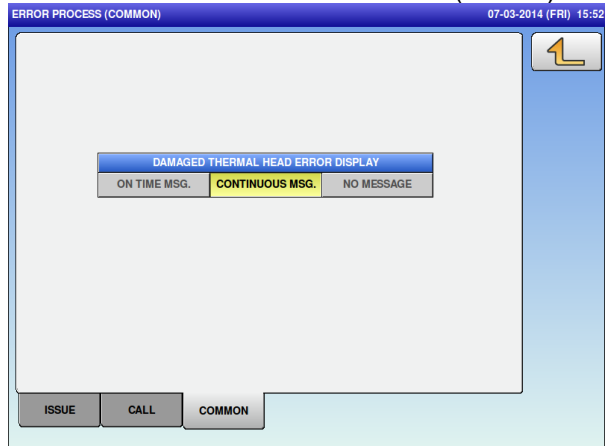

Screen 38: ERROR PROCESS (COMMON)

2) Other general items to be set (SETUP mode)

- MACHINE No.
- DATA STORAGE
- BARCODE
- PASSWORD
- PLU OVERWRITE
- OPERATION SETTING
- KEY LOCK
- PLU UPDATE
- FILE SAVE/LOAD

3) Downloading the user data

When using the USB flash memory that contains the user data, touch [FILE SAVE/LOAD] button -> [USB>SCALE] tab to download the data to the machine.

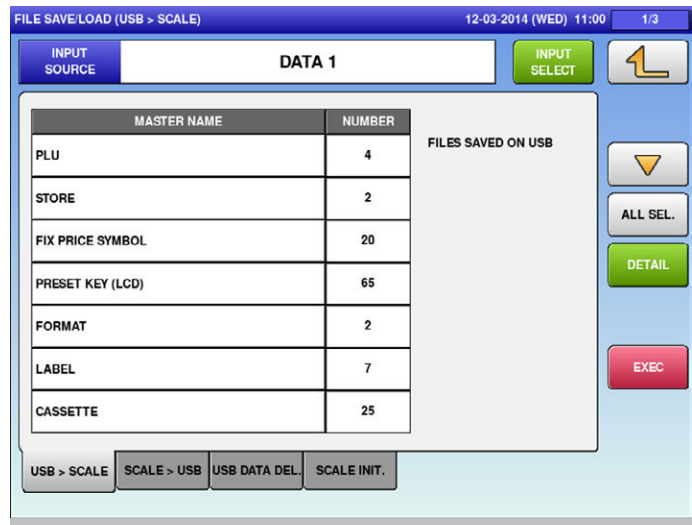

After setting up, to return to [MENU] screen, back to [Prepack] screen temporarily.

Then press  at the upper right side of the screen, and touch [LOGIN] button on the screen.

Chapter 2 Mechanical Adjustment

2.1 Overview

2.1.1 Applicator Unit

2.1.1.1 Structure

1. Driving Direction and Motor

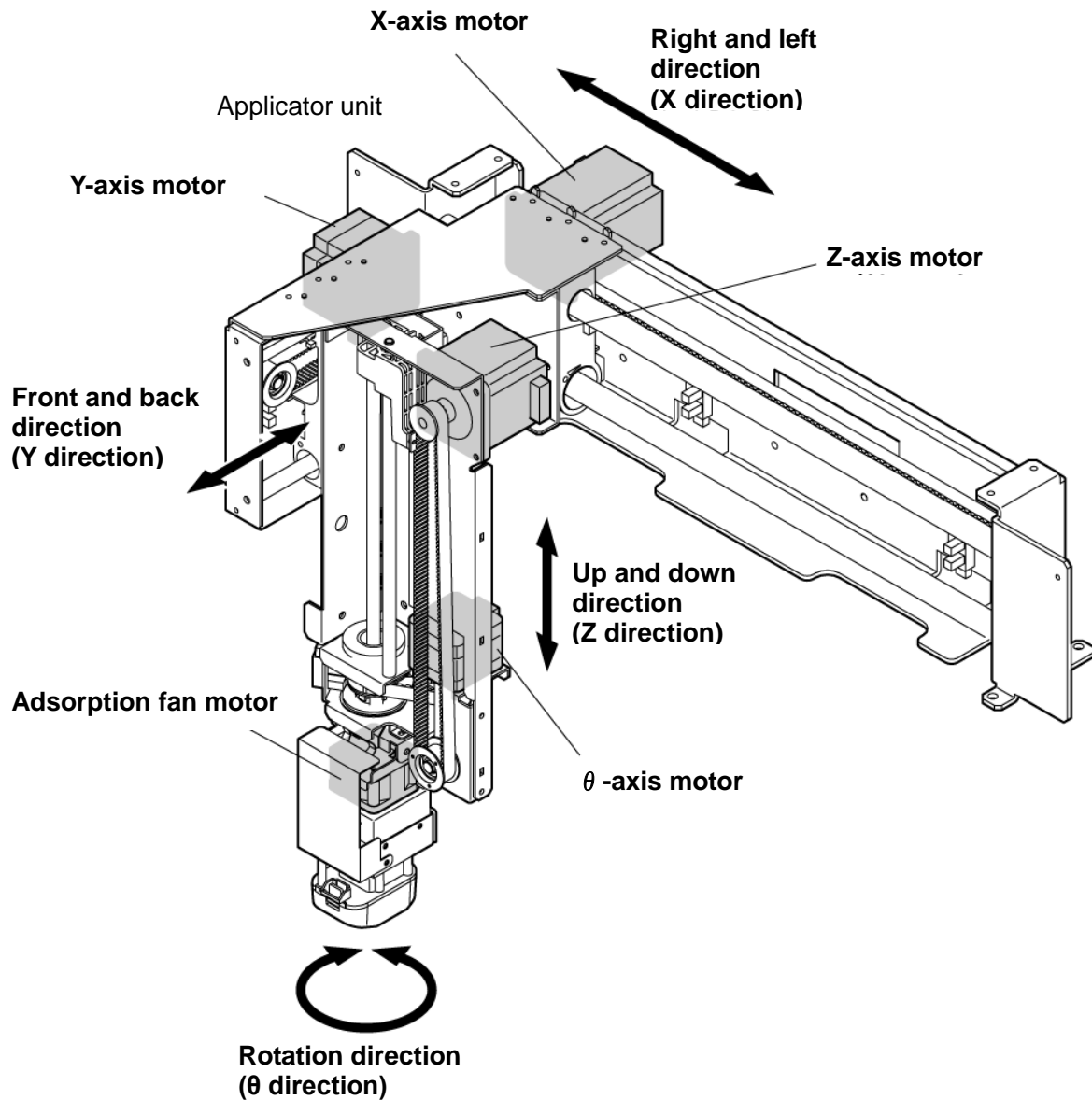

2. Sensor Position

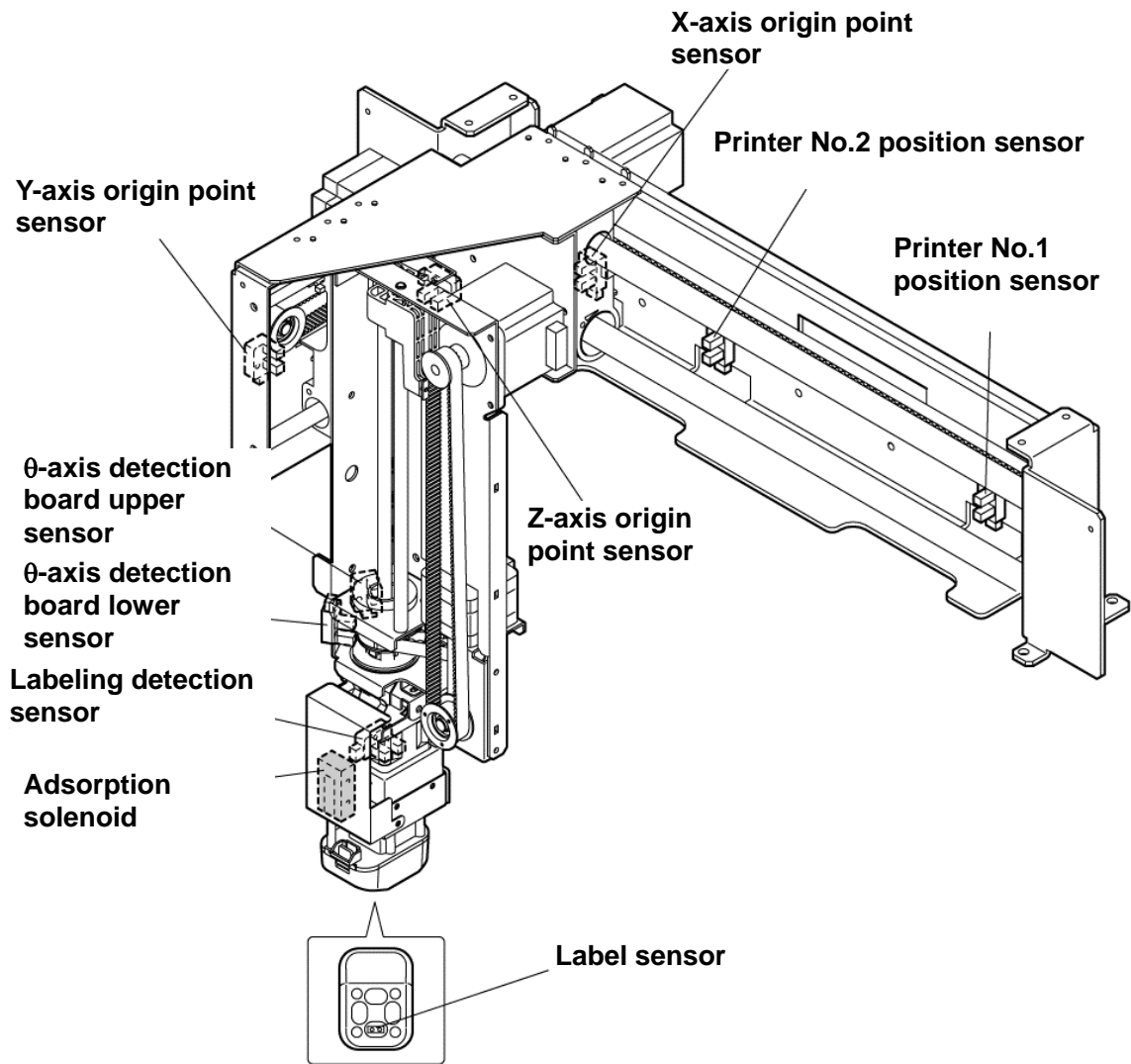

2.1.2 Feeder Unit

2.1.2.1 Structure

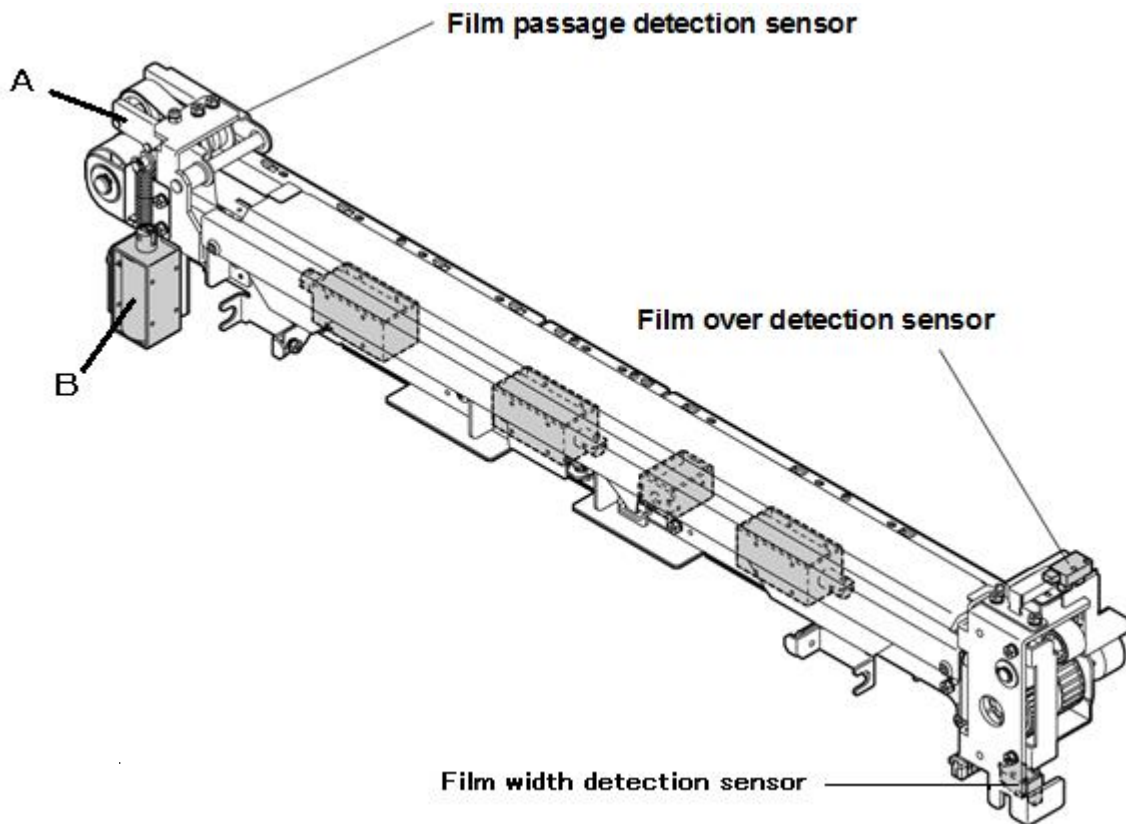

Figure 1 Film feeder (front)

2.1.2.2 Sensor

1) Film over detection sensor

This sensor detects film over.

In this detection method, when a film comes into contact with the detection board, the movement of the detection board is detected by photointerrupter.

- Normally: not receiving light
- When film over/ film passage: receiving light

2) Film passage detection sensor

This sensor detects a film passage.

3) Film width detection sensor

This sensor detects a film width (origin point).

2.1.2.3 Part Name

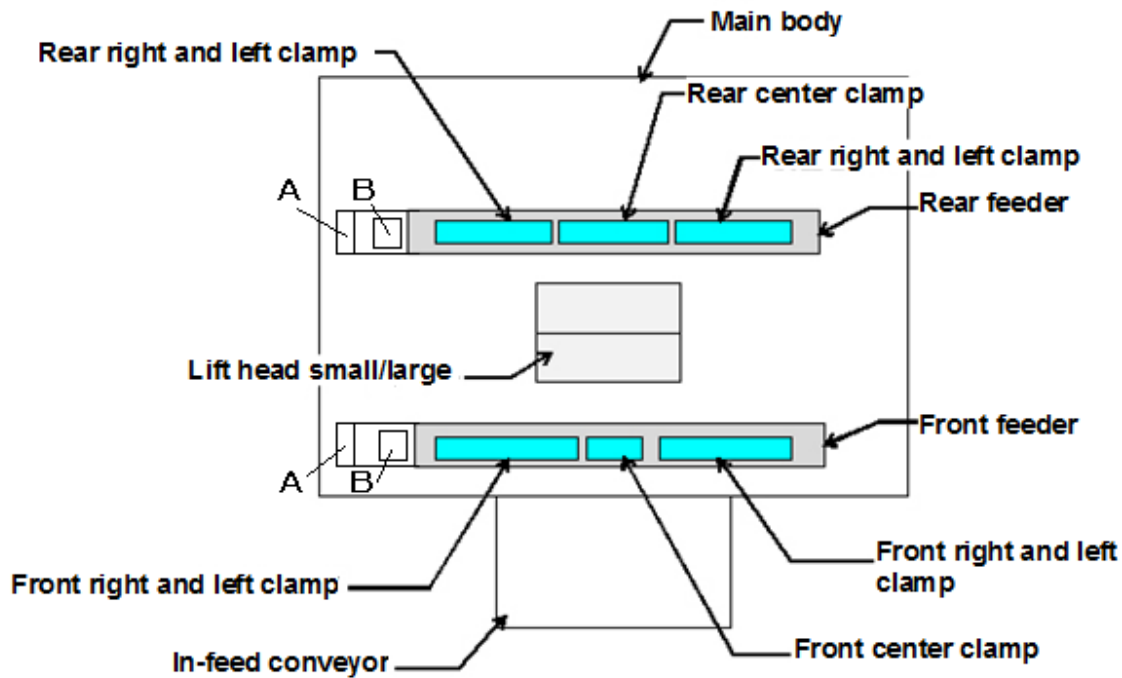

Figure 2 Feeder unit (top view)

2.1.2.4 Action

1) Film loading

In Figure 1, the deliver unit inserts a film forefront into the (A) position. After the solenoid of the (B) position starts operating, the (A) position pinches the close film. The timing belt starts rotating and sends the film to the clamp. After a portion of the film is delivered (when the film falls down the detection board of the rear sensor / when time is run out), the distance between the front feeder and the rear feeder becomes wider, the film is stretched, and then unnecessary films is cut. After the film is cut by an operator, loading is completed.

2) Wrapping

The deliver unit inserts a film forefront into the (A) position. After the solenoid of the (B) position starts operating, the (A) position pinches the close film. The timing belt starts rotating and sends a film at necessary length. Clamp is closed and releases the film to start wrapping when the object is lifted by the lift and the film is folded in by the wrapping plate. Whether the wrapping is successful or not depends on the timing of the clamp action.

WM-AI has three clamps (clamps for center/ right/ left) respectively in the rear and front feeders. Clamp action changes depending on the tray size and film length.

2.1.3 Camera Unit

2.1.3.1 Standard type structure

Camera unit is located in forward side of the discharge unit.

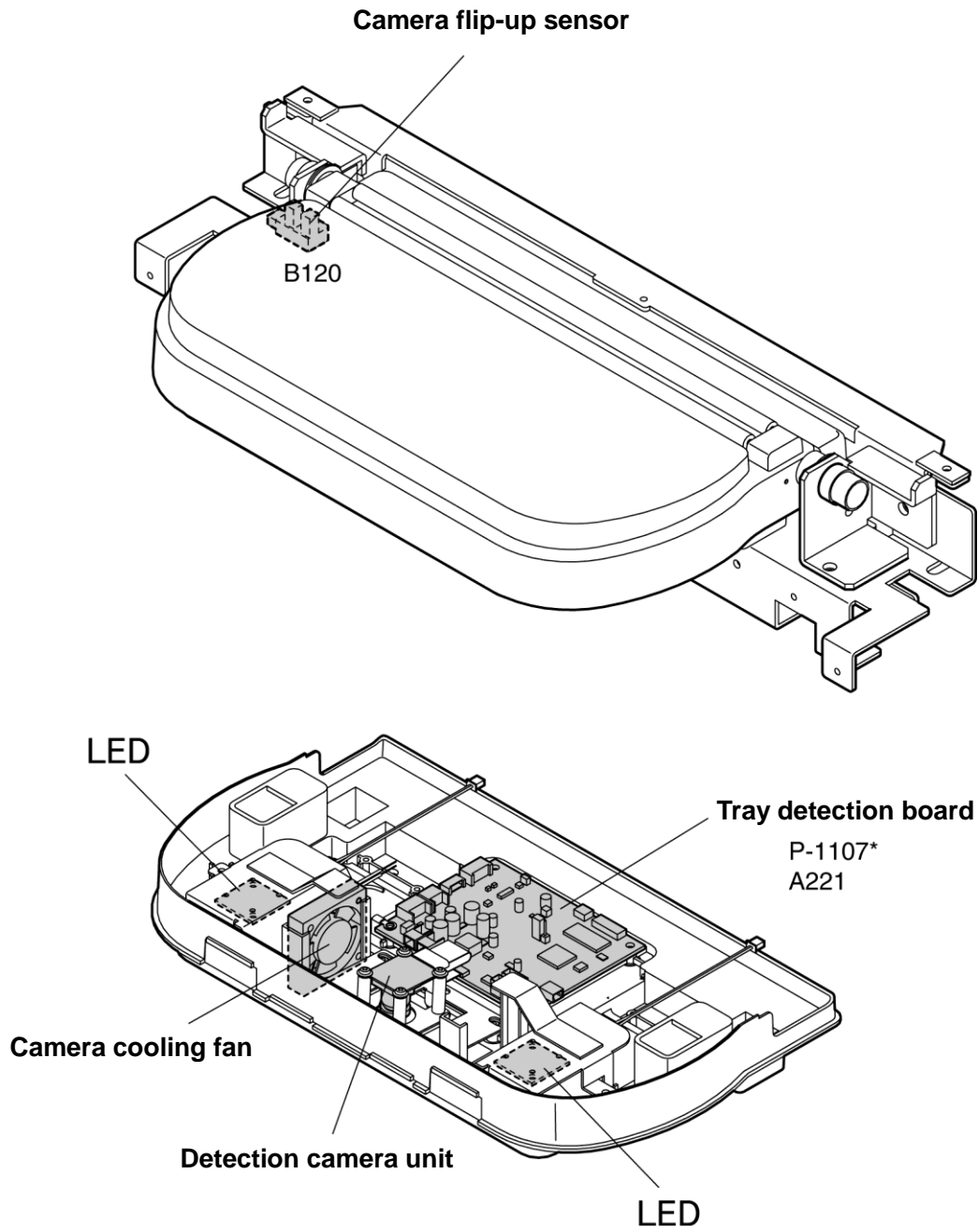

2.1.3.2 JR type structure



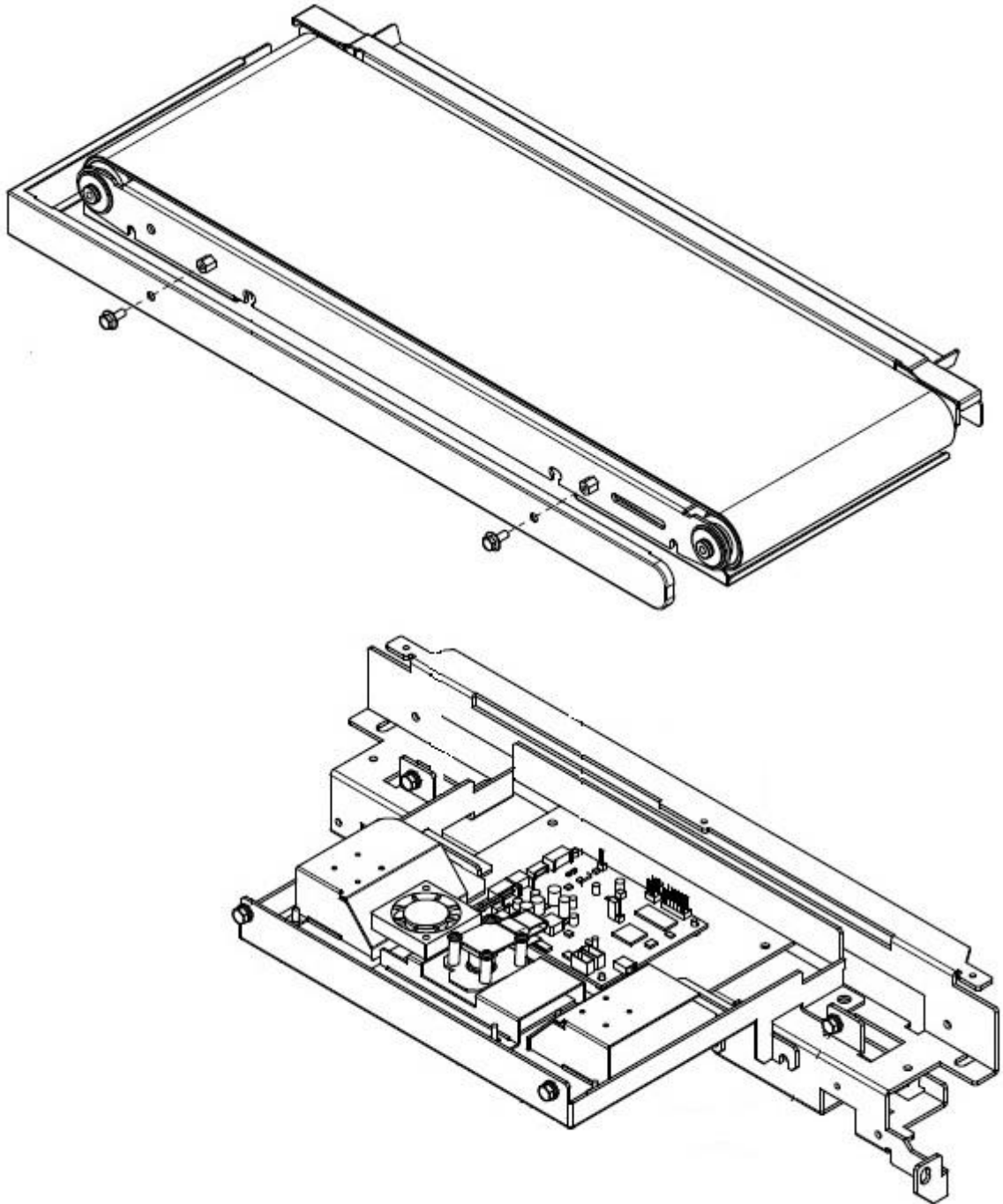



The camera unit is inside the discharge conveyor.

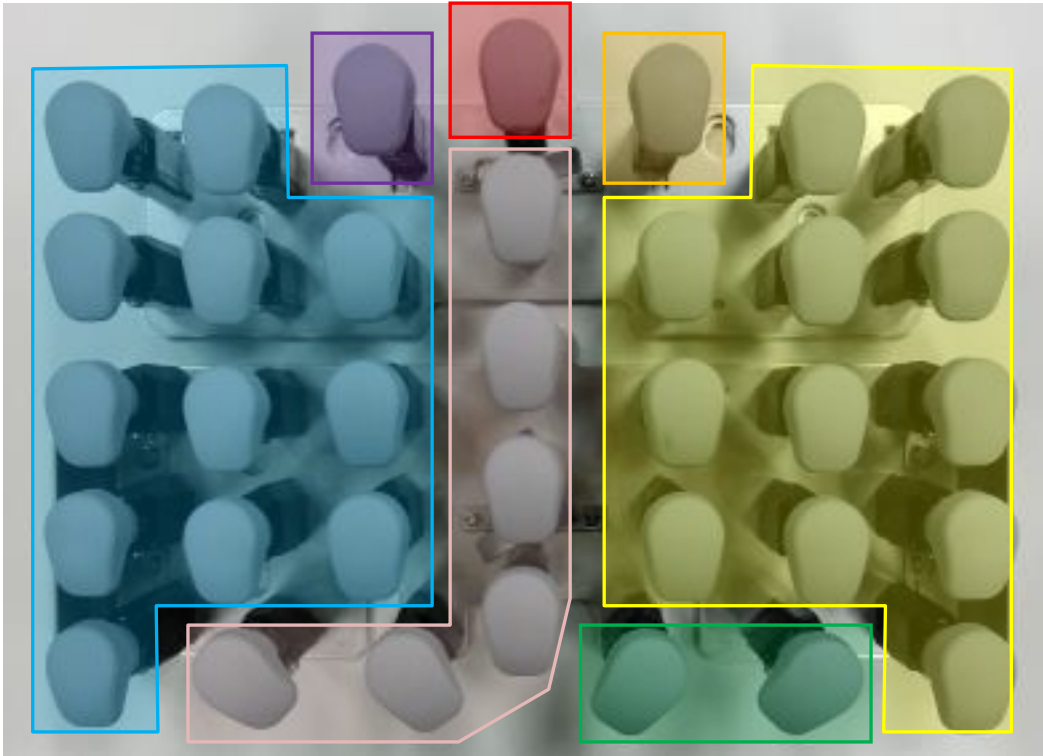

2.1.4 Lift Unit

2.1.4.1 Standard set



LF	000-112-6761-**		Pink
RF	000-112-6762-**		Green
L	000-112-6763-**		Blue
R	000-112-6764-**		Yellow
L with Blasting	000-150-7135-**		Purple
R with Blasting	000-150-7134-**		Orange
LF with Blasting	000-150-7136-**		Red

***The details of Blasting**

The (7) in the right image is with Blasting.
 And it has more durability.

***The details of Optional Black Head**

The (2) in the right image is Black with POM material.
 This has less friction against Tray.

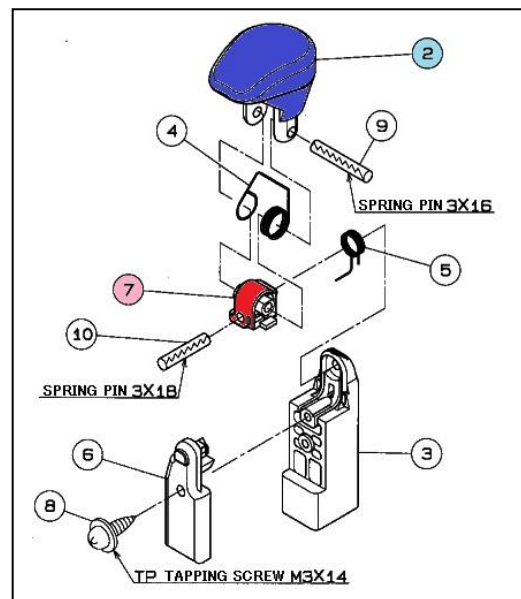

2.1.5 Electromagnetic Brake

2.1.5.1 Function

- For safety operation of this machine, if the lift is stopped during going up and down, brake is applied by the electromagnetic brake attached on the lift drive motor so that the lift is stopped.
- The electromagnetic brake is a non-excitation actuating brake that applies the brake when power is cut such as power outage or by pressing the emergency stop switch.

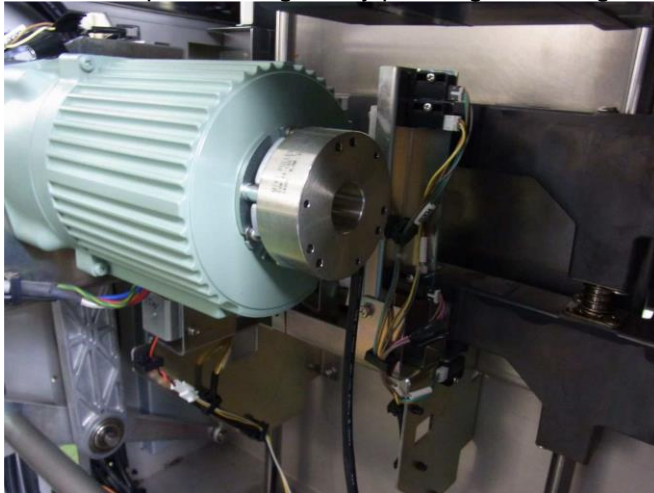

Gear motor model No. GMTA200-18U25
Brake model No. BXW-03-10-26

2.1.5.2 How to operate

- While brake is applied to a lift by the electromagnetic brake, the lift does not go down by hand. To manually move up and down the lift, insert a flathead screwdriver into the center of the electromagnetic brake that is located in the rear position of soft motor and turn it.

2.1.5.3 Structure

- While turning the drive shaft of the DC brushless motor using the flathead screwdriver, brake is still applied by the electromagnetic brake.
- As the brake force by electromagnetic brake is small, the shaft can be turned by hand.
- As to rotation of the lift drive motor, the gear moves up and down the lift by slowing its speed. Therefore, the lift cannot be moved easily by hand.
- The electromagnetic brake is run by spring when 24 V DC for drive system is cut off and the electromagnetic brake becomes non-excited.

2.2 Adjusting the Mechanical Units

2.2.1 Printer Unit

2.2.1.1 Adjusting the label guide width

The center of label is set as its standard position. In accordance with the label width, change the guide positions that are shown in the figure below.

For a 71 to 80 mm wide label, use the collar "step" face down, change the location of the roller "guide" and guide "label", and add flat washers.

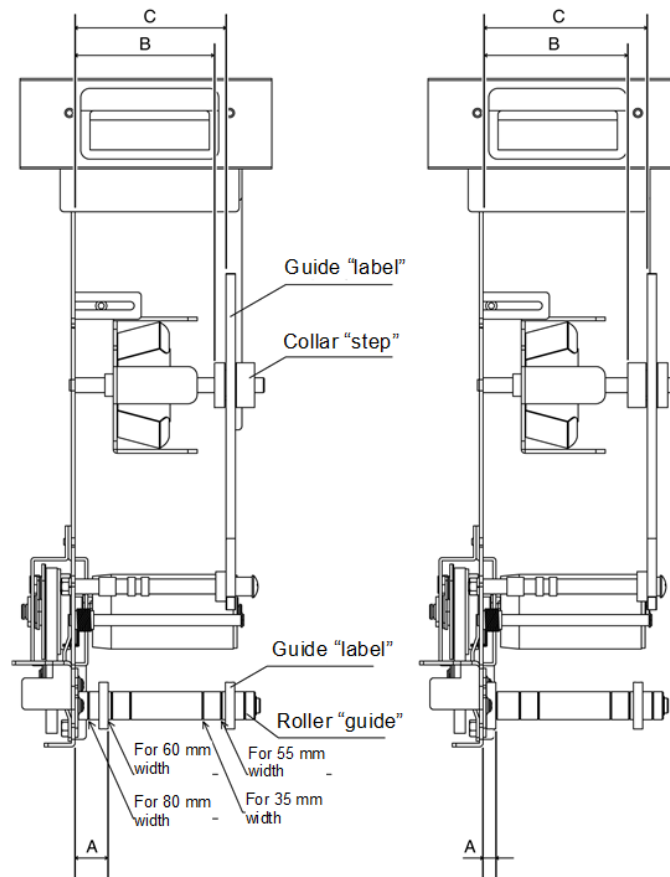

For a 35 to 70 mm wide label

For a 71 to 80 mm wide label

Label width	A	B	C
35 mm	30.0 mm	62.0 mm	67.5 mm
55 mm	20.0 mm	72.0 mm	77.5 mm
60 mm	17.5 mm	74.5 mm	80.0 mm
80 mm	7.5 mm	80.2 mm	90.0 mm

2.2.1.2 Changing the label sensor position

Depending on the label size (length and gap), when a label gap is stopped in the label sensor position, the number of feeding times increases to adjust the label into the specified position for replacement. In addition, an error of label size may occur when printing labels.

To prevent this, if the label gap and the label sensor are overlapped, move the sensor backward in a direction to be separated from the label gap.

The pitch is 7 mm

When the sensor position is changed, set a distance of label sensor at +7 mm.

1. Install the label sensor horizontally to the frame and make sure the sensor moves smoothly.
2. Install the label sensor so that large fluctuations are avoided when printing labels.

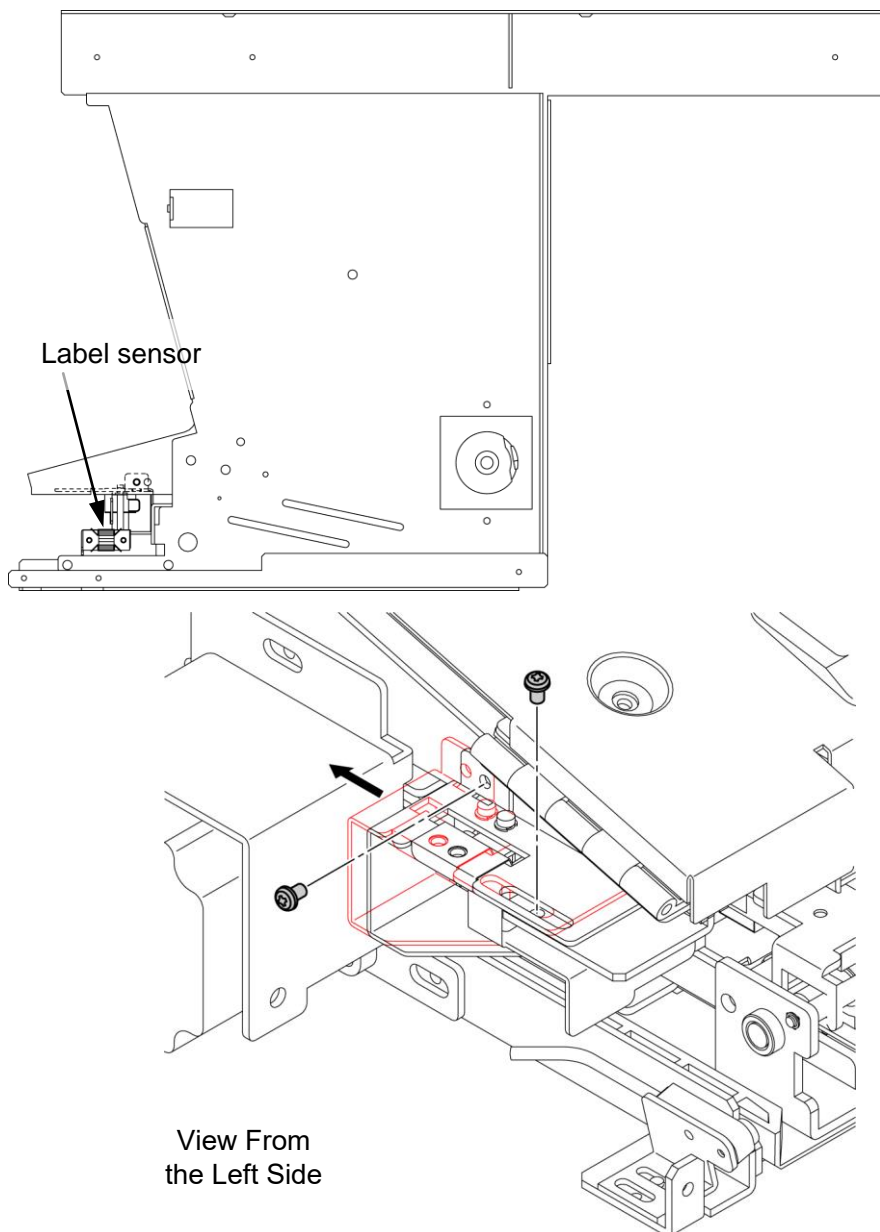

2.2.1.3 Changing positions of bracket for guide roller and label press

In a standby state, if a label end is placed in the roller “guide”, the label after being printed will be warped and dropped from the peel shaft before the applicator sucks the label.

Install position depends on [label top-to-bottom size] + [label gap].

For WM-AI, use two screws to change the position.

Position of standard printer at shipment

	Dimensions of A	Dimensions of B
• Printer single (left): 55 mm of label top-to-bottom size	10 mm	35 mm
• Printer dual (right): 37 mm of label top-to-bottom size	1 mm	26 mm

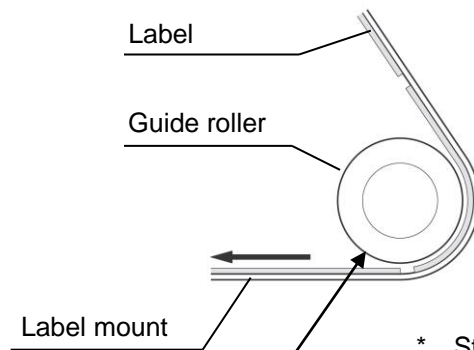
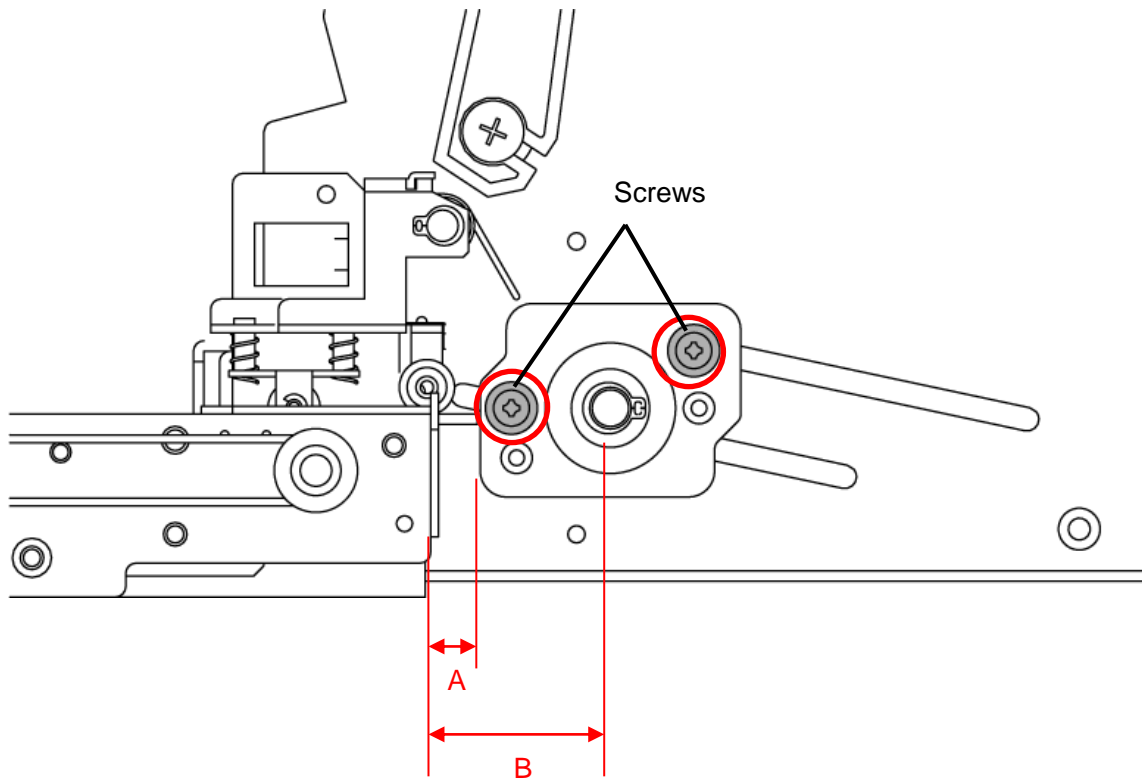

* Straighten the label at the back to prevent the development of the curl tendency of the label.

All of ISHIDA genuine labels are for winding outward.

2.2.1.4 Handling Methods in Case of a Label Size Error

Cause behind the occurrence of a label size error

In either case of "after feeding" or "after back-feeding", and when the edge of a label is located immediately below the label sensor at the label stop position, a label size error may occur.

This is caused by a miscalculation of the label length by a mixture of the case to detect a label and the case to detect the gap when the label sensor starts operating.

Handling methods

Three handling methods are described below.

First of all, handle the error after predicting by visual observation whether the error detection by the label sensor that may causes a label size error has occurred at the stop position "after feeding" or it has occurred at the stop position "after back-feeding".

(1) Changing the label sensor position

Please refer to Chapter 2 "Changing the Label Sensor Position".

This is effective in handling an error when the label edge is located immediately below the label sensor "after feeding" or "after back-feeding".

Change the position by moving the label sensor position.

(2) Changing the pre-stop position

This is effective in handling an error when the label edge is located immediately below the label sensor "after feeding" or "after back-feeding". The purpose is to change the label stop position by changing the value of pre-stop position in the printer mode.

Note: The pre-stop position is used to adjust the amount of a label remaining on the peeling bar.

Change the value of pre-stop position within the range where the purpose is not hindered.

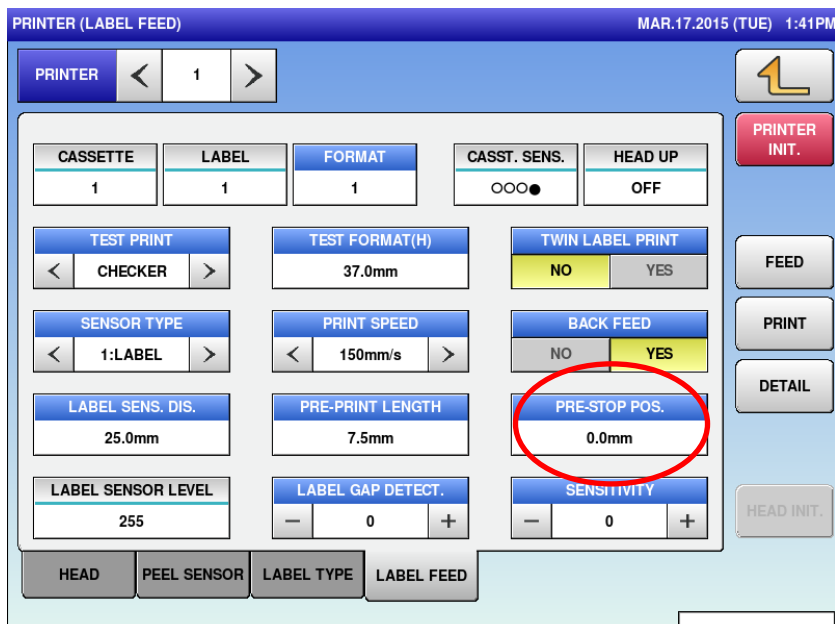

(3) Changing the backing feeding amount

This is effective in handling an error when the label edge is located immediately below the label sensor "after back-feeding". The purpose is to change the label stop position after back-feeding by changing the back feeding amount in the printer mode.

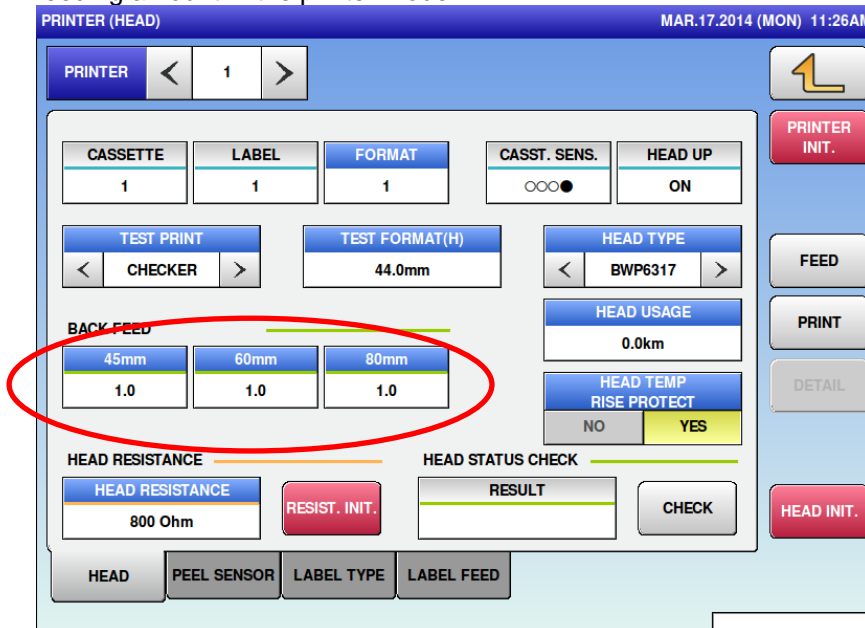

2.2.1.5 Changing layout (interval) of the label standby roller

When the right and left sides of labels are located in the inclined part or forefront of the roller, the label may get caught in the roller during the feed operation. This may cause the label to be warped and results in a suction error. In accordance with the label width, change the number of collars in the roller (3 mm wide).

< Machine No.1 >

Label width: 60 to 80 mm

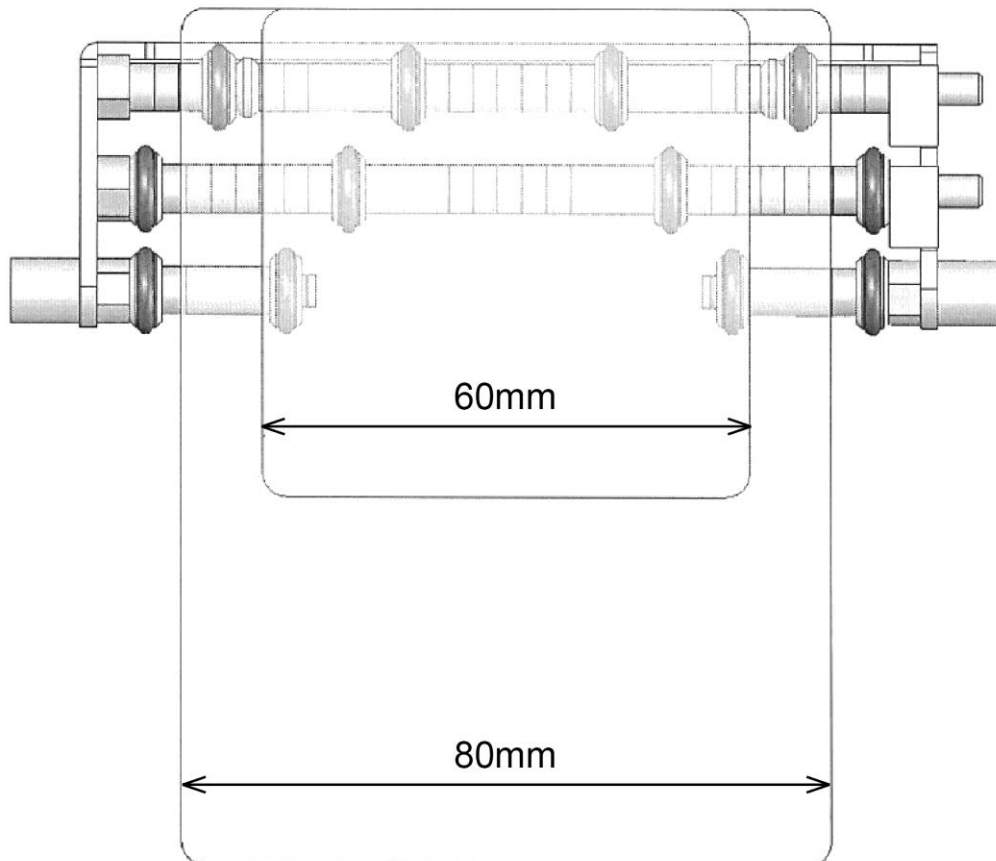

The figure above shows the default setting. No change is needed for the label width of 60 to 80 mm.

Label width: 45 mm or more but less than 60 mm

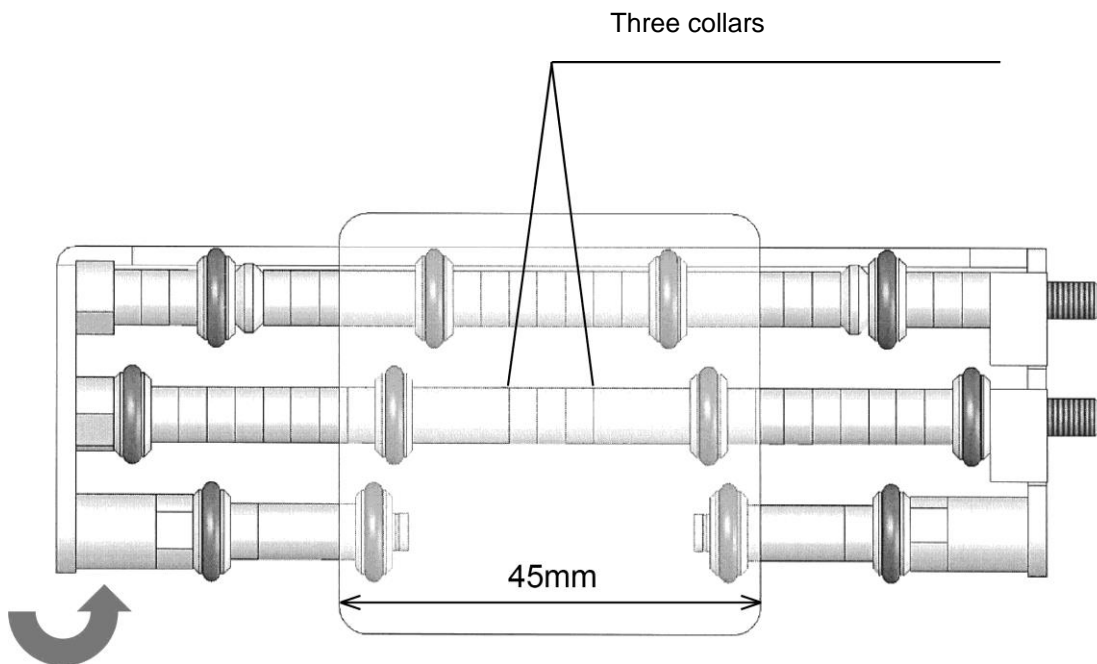

* When the label width is 45 mm or more but less than 60 mm, metal collars (both sides) mounted outside the triple standby roller need to be moved inside.

Label width: 35 mm or more but less than 45 mm

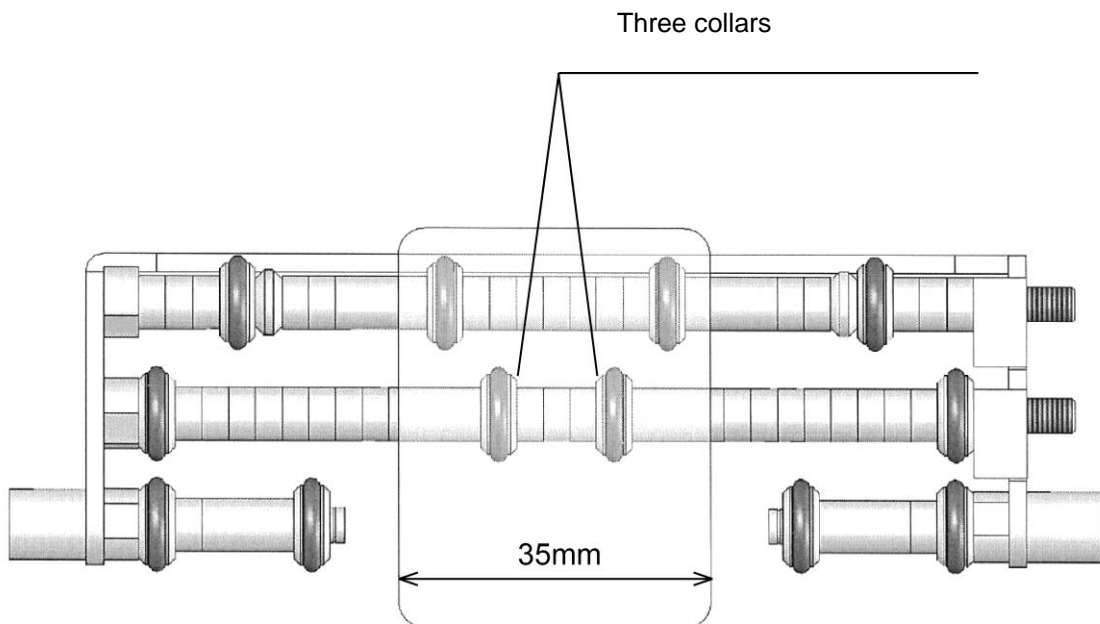

* When the label width is less than 45 mm, only the second standby roller is used and the triple standby roller is not used.

< Machine No.2 >

Label width: 35 mm/ 60 mm/ 80 mm

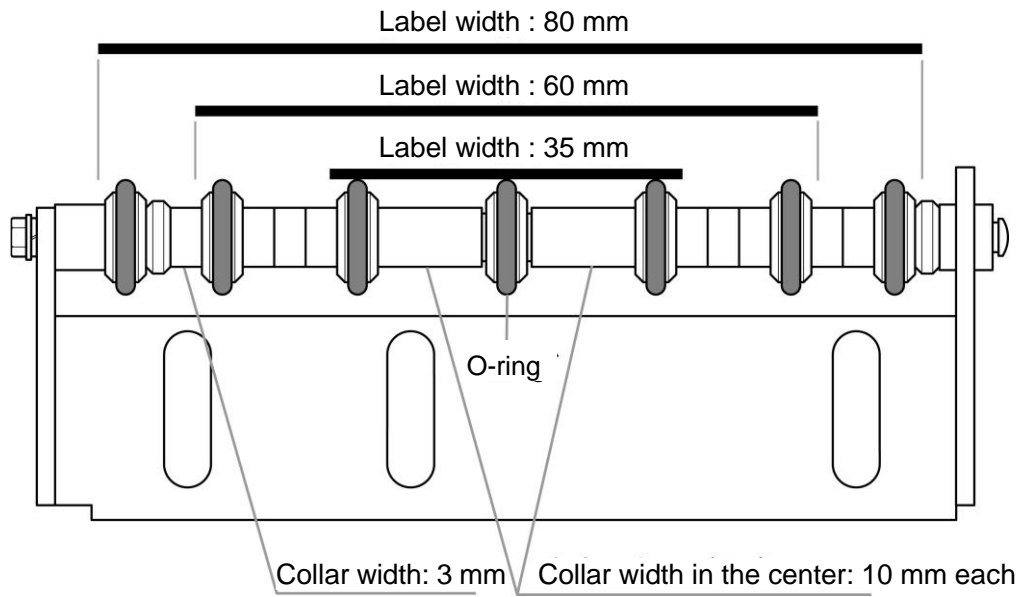

Label width: 55 mm

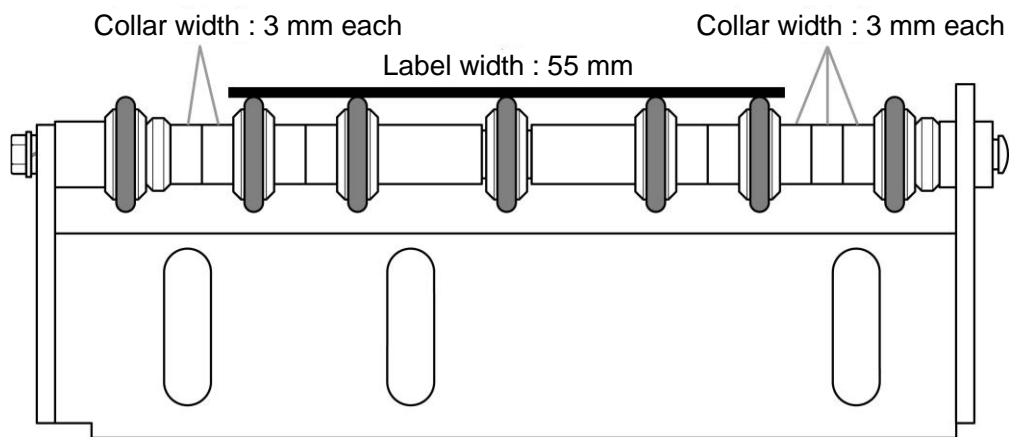

Explanation is provided using a single label standby roller. The same explanation applies to the multiple label standby rollers.

2.2.1.6 Adjusting front and rear position of the label standby roller

If the label width is more than 43 mm (top-to-bottom size), detach and attach the standby roller as shown below.

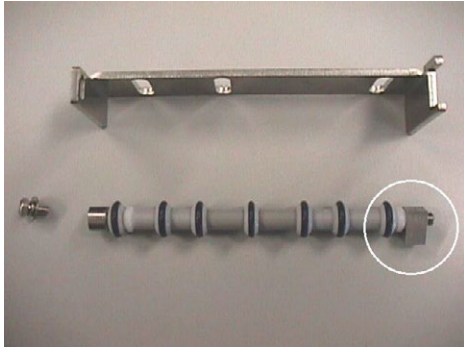

After detaching the label standby roller

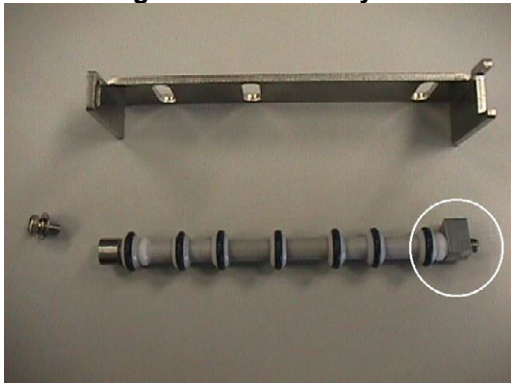

After attaching the label standby roller



How to attach the label standby roller

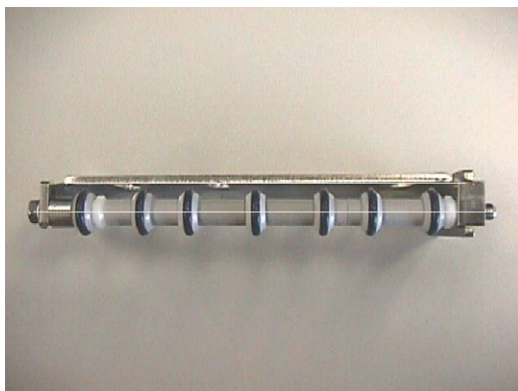

Check after attaching the label standby roller

(1) Detach the standby roller from the bracket. Do not rotate the block A'assist'to the face D of the shaft "step". Doing so results in a change in collar's interval. If the interval becomes narrower, the collar does not rotate smoothly, which worsens a label feed.

(2) Make the roller unit a half-turn without rotating the block A'assist'to the face D of the shaft "step" (screw is placed in forward side).

(3) By keeping the status of step (2), attach the standby roller to the frame "support". Bring the shaft "step" to the forward lower position as shown in the picture and fix it.

(4) Check the following points:
The standby roller and frame "support" are located in parallel. The roller can rotate slightly (Roller space is 0.5 to 1.1 mm).
→How to adjust: loose the screws and rotate the shaft "step".



Check after attaching the standby roller

(5) Check the following points:

The bottom of the block A'assist' is located along notches of the frame "support".

By default, layout of O-ring is set for a 60 mm wide label.

2.2.1.7 Adjusting the upper and lower positions of label standby roller unit

To easily check the adjustment in upper and lower positions of the label standby roller, white collars (indicated by the arrow in picture), which are provided one each on the right and left sides, are used.

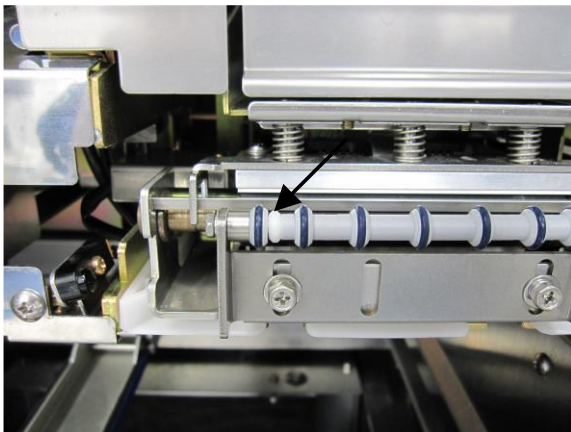

Fix the standby roller unit so that the top of white collar and the top of peel shaft forefront are located at the same height level.

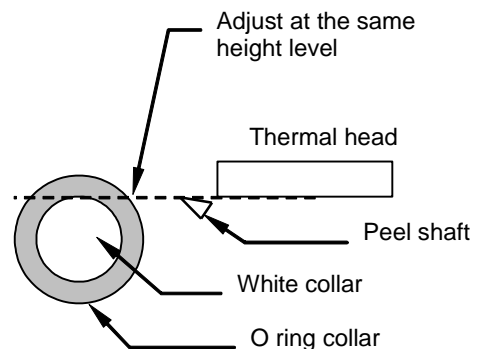

<How to check>



- Place a metal scale on the peel shaft to check the distance between the collar and the scale.
- The picture shows that top of the left white collar and top of peel shaft are at the same level.

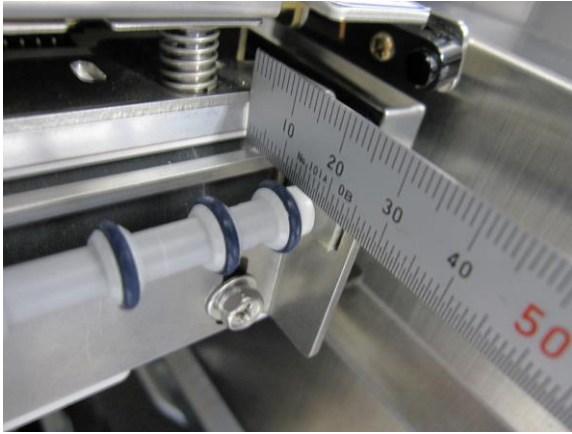

- The picture shows that top of the right white collar and top of peel shaft are at the same level.

2.2.1.8 Adjusting the label standby roller unit

Adjust the height of the label standby roller so that a label part that is sucked by the suction block is located horizontally when printing labels. If it is entirely hanging down, raise the height of the label standby roller.

If the label is warped upward, locate the height of the standby roller 0 to 0.5 mm lower than the peel shaft so that the label part that is sucked by the suction block is installed horizontally.

For a long label, increase the advanced feed stop amount to leave less label in the peel shaft so that the label to be warped upward is minimized.

For a flat label, it is normal if top of the roller of the label standby roller is located 0.5 to 1 mm upper than the peel shaft.

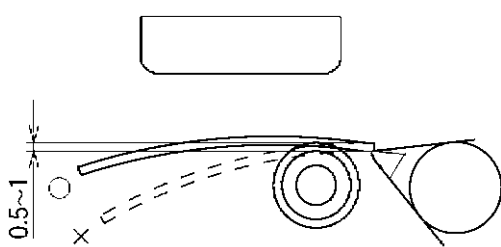

Normal

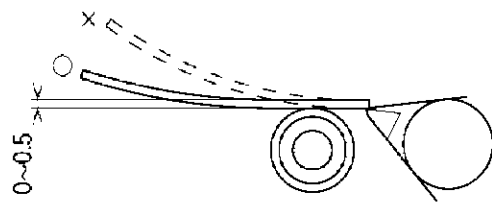

Label warped upward

2.2.1.9 Checking and adjusting the printing position (right and left sides)

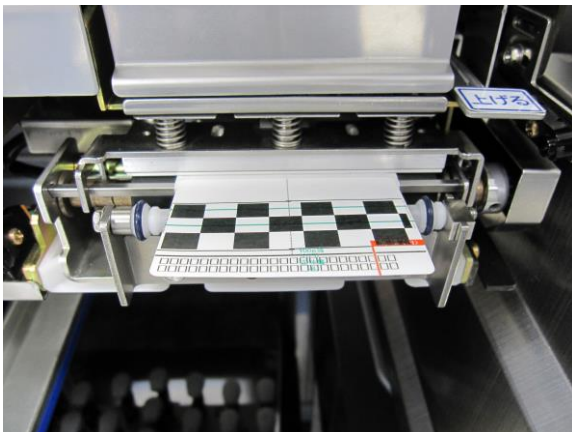

- To check the right and left sides of printing position of the screen, touch the [ADJUST] button -> [PRINTER] button -> [LABEL FEED] tab and press the [PRINT] button.
- Adjust the guide position of the printer so that the label is located in the center of the standby roller.
- If printed letters are aligned left or right, adjust the right and left positions of the thermal head. After adjustment, please confirm the contact (printing density) of the head.

2.2.1.10 Checking back feed

For No.1, and No.2 machines, touch the [ADJUST] button -> [PRINTER] button -> [LABEL FEED] tab and select [YES] for [BACK FEED].

2.2.1.11 Input the distance of label size, label gap

Each label manufacture offers slightly different size of label punching dies.

If an input value and the actual size are different, a label cannot be sucked successfully due to errors related to a printing position, label size, detection of label end, or label edge cut.

Measure the label length and the gap length that are actually used.

For No.1, and No.2 machines, touch the [ADJUST] button -> [PRINTER] button -> [LABEL TYPE] tab and enter values in [TEST FORMAT(H)] and [LABEL GAP].

Enter a value according to the label used.

Standard specifications at factory shipment

	Label width	Label length (top-to-bottom)	Label gap
Machine No.1 (left)	60 mm	55 mm	3.0 mm
Machine No.2 (right)	60 mm	37 mm	2.2 mm

2.2.1.12 Input the advanced feed amount

Adjust the position of label edge cut with the advanced feed amount.

Whether a label edge can be cut smoothly or not depends on qualities in label paper, label paste, label punching, label mount, and a label surface condition.

For No.1, and No.2 machines, optimize the status of label edge cut.

Use the following equation to determine the advanced feed amount.

$$\text{Advanced feed amount} = \left(\begin{array}{l} 9.5 \text{ mm of distance between} \\ \text{the printing position and peel} \\ \text{shaft forefront} \end{array} \right) - \text{Label gap}$$

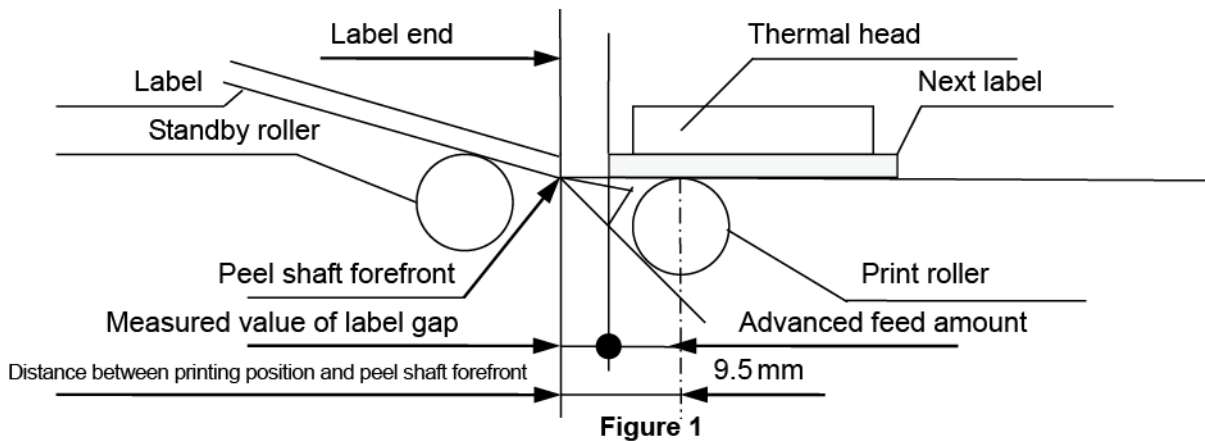
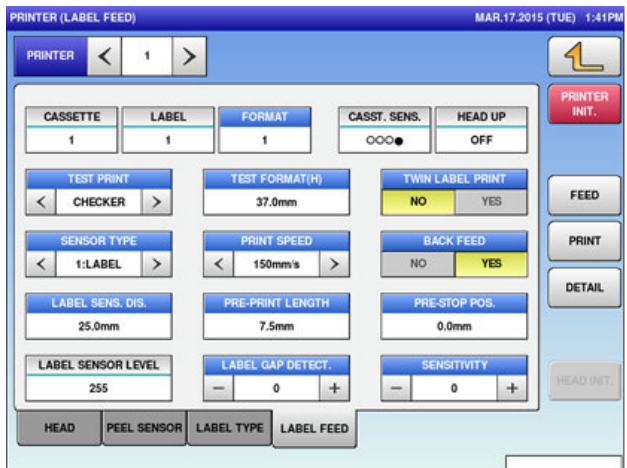

Figure 1 shows the optimum status of the label position, the label end after being printed is located in the peel shaft forefront (do not feed the label too much).

In actual operation, it is normal if the distance, which is measured between the next label forefront and the peel shaft forefront, is matched with the measured value of the label gap.

2.2.1.13 Setting the distance of label sensor

Label sensor distance: Select [CHECKER] for [TEST PRINT], measure the position of a ruled line of thermal print, which is located above an address / store name, from the bottom of the label. Enter a value in the [LABEL SENS. DIS.] shown on the screen below so that the measured size and the value inputted in [advanced feed amount] become the same.



2.2.1.14 Input the advanced feed stop position

If an extremely large value (example: [advanced feed amount]=7.5 mm etc.) is entered in [advanced feed stop amount], the label, which is temporarily stopped in the peel shaft before being sucked, is peeled off from the label mount. This results in an error stating "It could not suck label".

To prevent this, make the following settings.

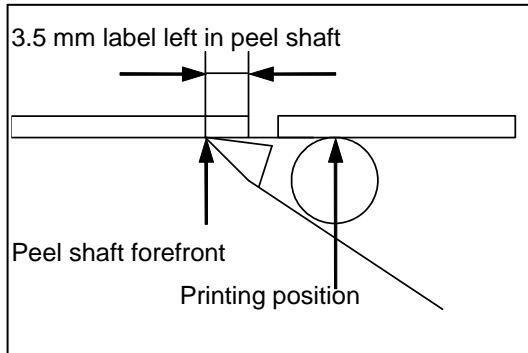

Labels are temporarily stayed and stopped in the peel shaft before being sucked.

For No.1, and No.2 machines, enter values in [advanced feed stop amount] so that the label end is left 3.5 mm in the peel shaft.

Advanced feed stop state

Description of [advanced feed stop position]

Set a value of advanced feed stop position in a range from C_{min} to C_{max} .

The value 'C' changes depending on peel ability of the label mount.

C_{min} : Advanced feed stop position (mm) = B (9.5 mm) - A (3.0 mm) - gap length

C_{max} : Advanced feed stop position (mm) = B (9.5 mm) - A (3.5 mm) - gap length

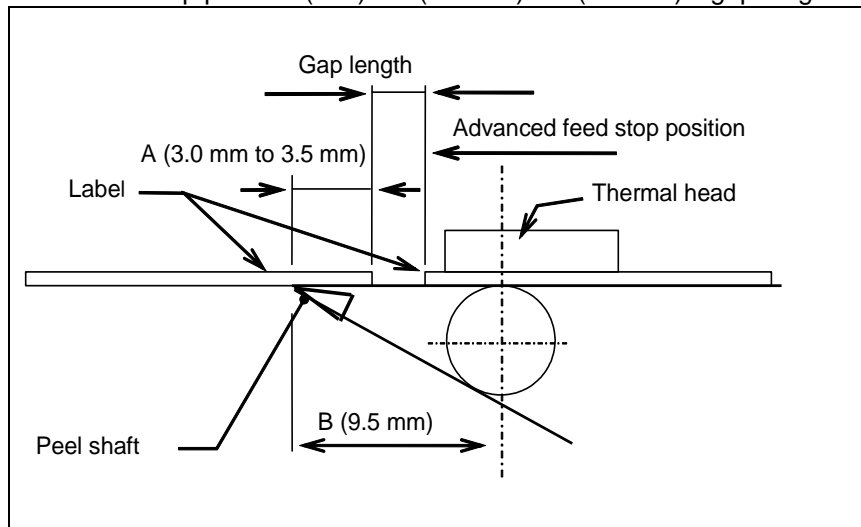

Advanced feed stop position

To leave the 3.5 mm label in the peel shaft,

[Advanced feed stop position] = [advanced feed amount] - (3.5 mm label left in peel shaft)

Set [advanced feed stop position] according to [advanced feed amount] that is set at 0.

At factory shipment, [advanced feed stop position] is set at the following referential value as standard specification.

Machine No.1 [advanced feed stop position]: $7.3 - 3.5 = 3.8$

Machine No.2 [advanced feed stop position]: $6.5 - 3.5 = 3.0$

2.2.1.15 Setting the advanced feed amount, advanced feed stop position

To adjust, change a value of [advanced feed amount]. By increasing the value of advanced feed amount, the label can be fed further and then stopped. To check the status of label edge cut, enter the same value as [advanced feed amount] in [advanced feed stop amount] until the status becomes as shown in Figure 1.

After checking the status as shown in Figure 1, then, set a correct value of [advanced feed stop amount].

2.2.1.16 Checking the peel sensor level (optical axis)

To check the peel sensor level, touch the [ADJUST] button -> [PRINTER] button -> [PEEL SENSOR] tab. It is normal when [PEEL SENSOR LEVEL] is more than 130. If the value is less than 130, set [PEEL SENSITIVITY] to more than 130. Adjust the front/ rear position of the peel sensor bracket on the right and left sides so that [PEEL SENSOR LEVEL] is set at more than 130. On the other hand, check the peel sensor level less than 20 when the label is existing.

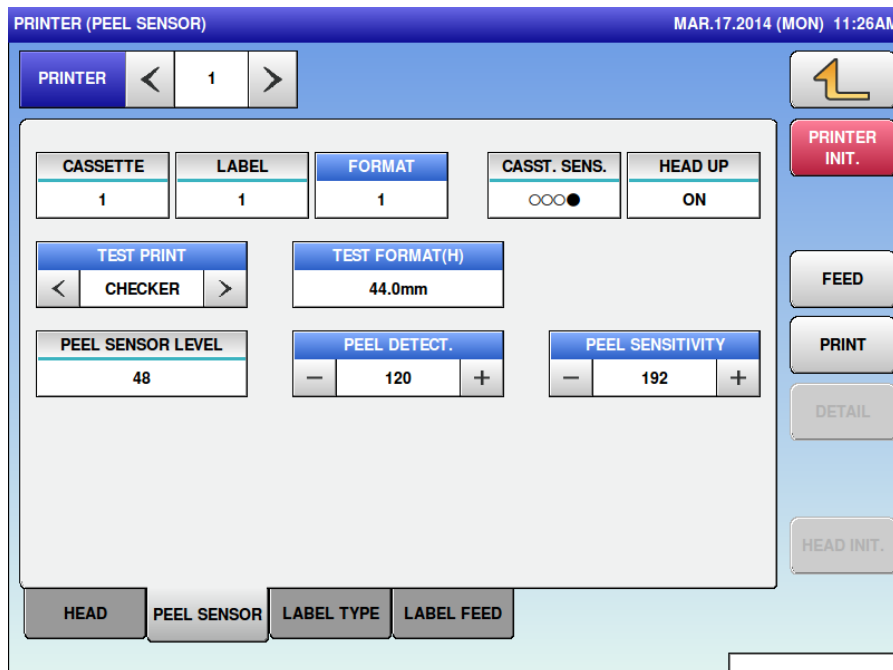

2.2.2 Applicator unit

2.2.2.1 Checking the coiled cord mounting status

Use the following procedure to check the coiled cord mounting status.



WARNING

Check with the emergency stop button depressed.

1. Secure the movements in the up and down directions at a position with a gap of approx. 2 to 4mm between the suction part and the bearing. (In the photo, the belt is held.)

2 to 4mm

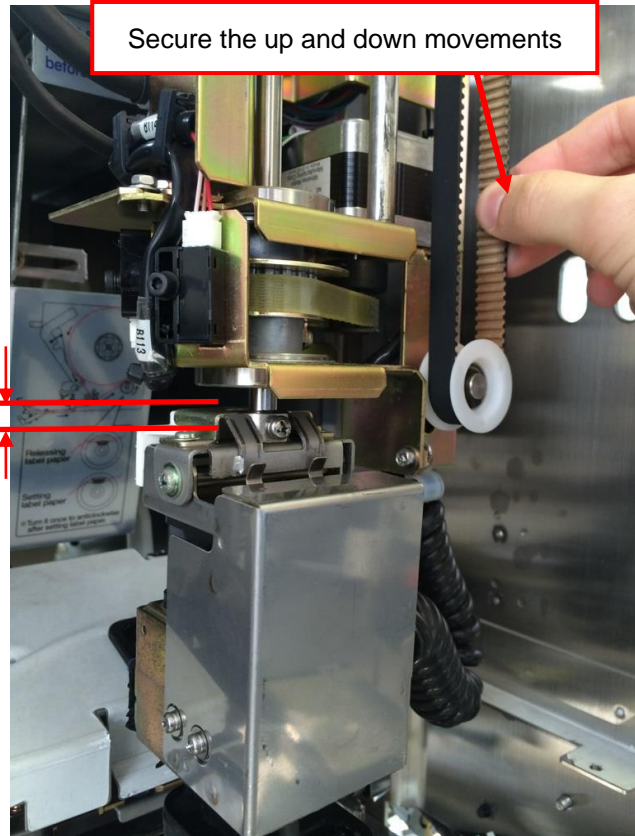

2. Place the suction surface directly opposite, and release your hand. The status is correct is the suction part does not rotate and remains stationary in that position.

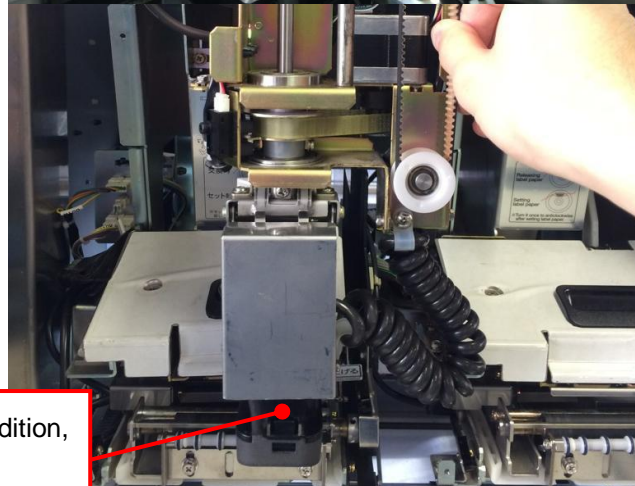

If stationary in this condition,
everything is OK

- Secure the nylon clamp so that the free part of the coiled cord makes 17 windings. (The number 17 does not include the secured parts at both ends of the nylon clamp.)

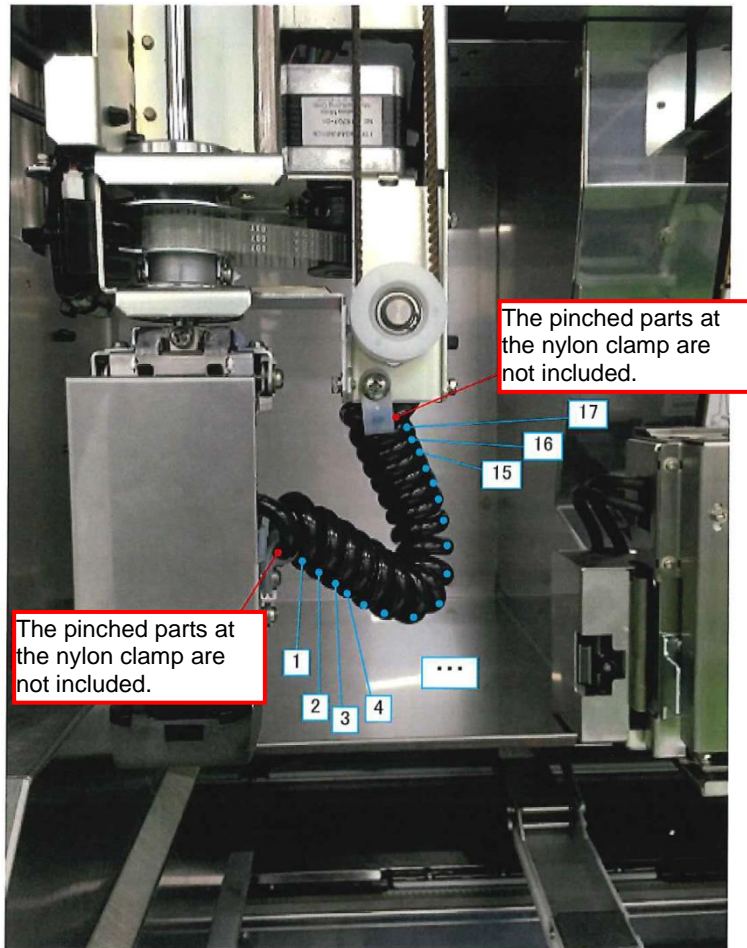

- Mount the frame while paying attention to the orientation of the nylon clamp.

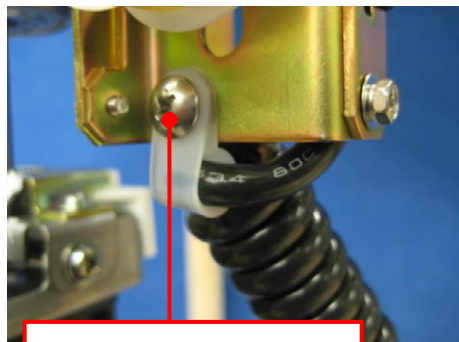

Clamp mounting orientation

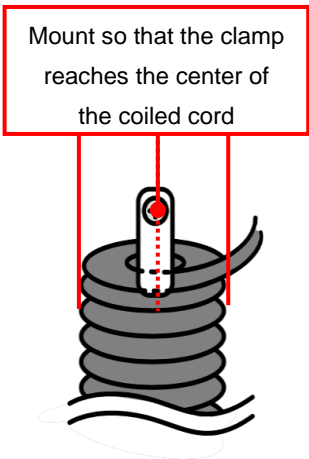

■ Precautions when mounting the applicator suction part

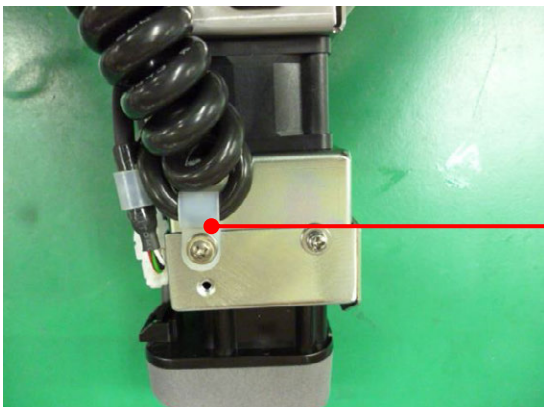

Secure in the following order: clamp, washer, washer, TP screw

5. If the coiled cord becomes twisted, the pressure on the cord will rotate the suction part as shown in the photo. Remove the brake clamp and Insulock, remove the cord twists, and remount.

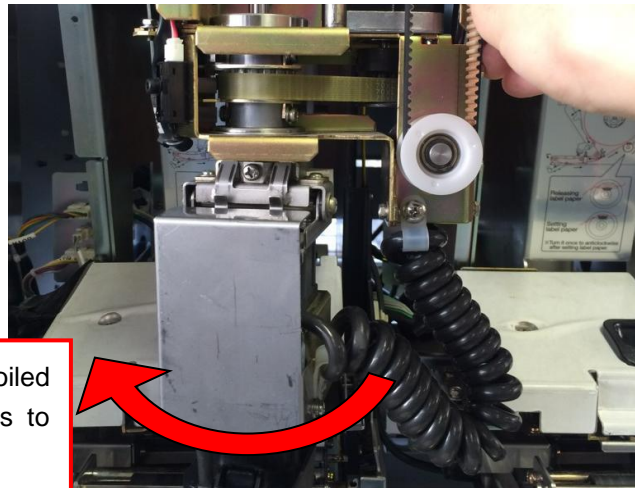

If pressure is applied to the coiled cord and the suction part rotates to the left, there is a problem

■ **Methods for checking after processing the applicator's coiled cord wiring**

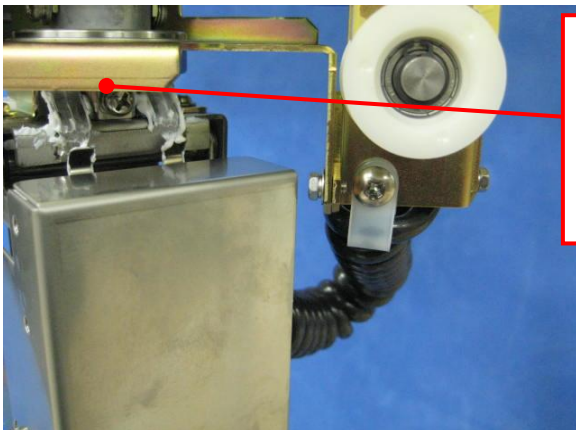

Checking the coiled cord
Align the top of the labeling machine suction part and the bottom of the bearing to 2 to 4mm, and face the suction part forward, and then check that the suction part is not misaligned. If it is misaligned, adjust the coiled cord securing position.

2.2.2.2 Suction method (winding outward label)

- In this suction method, a label is first pinched between the standby roller and the suction block in the suction position, pulled out, and then transferred to the paste position.
- The following figure shows the status of label suction. The label is held down by the suction block so that the label end is raised up and the label edge is cut smoothly. This method is effective for propeller-shape warped labels (properly adjust printer and applicator)

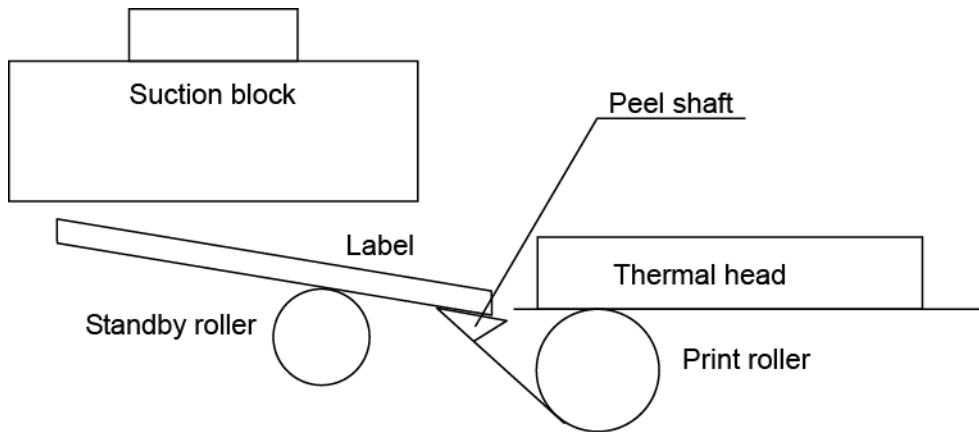

Leave 3.5 mm of label end temporarily in the label mount.

Figure 1 Advanced feed stop state

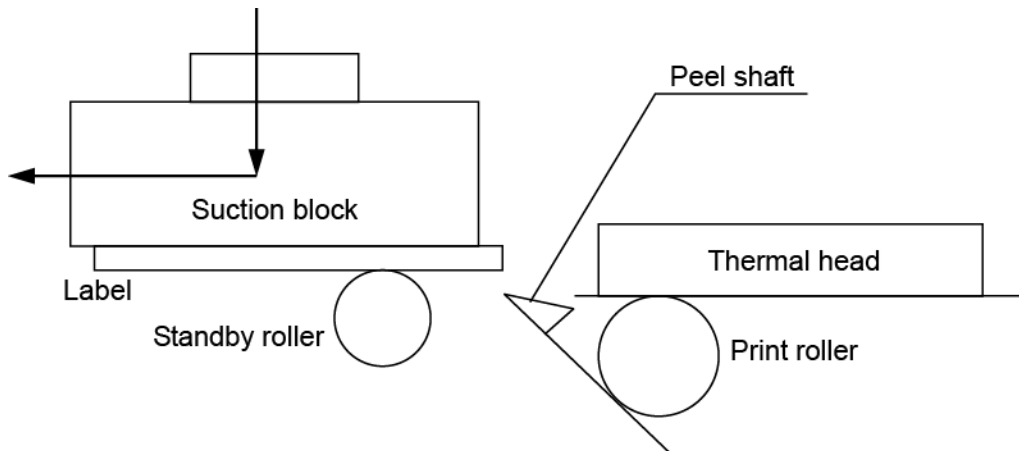

Feed the label end again to the forefront of the peel shaft. The label is first pinched between the standby roller and the suction block, and then pulled out.

Figure 2 Suction operation

2.2.2.3 Adjusting the suction position

Right and left positions

To check the suction position (right and left sides), touch the [ADJUST] button -> [LABEL APPLICATOR] button -> [POS.] tab. For No.1 and No.2 machines, set the right and left sides of the suction positions.

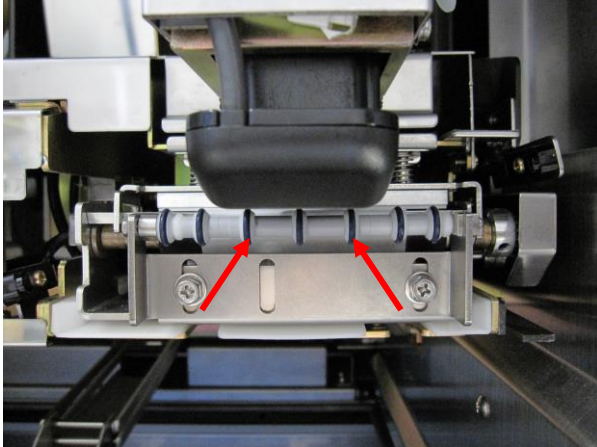

- Select the [NON PRINT CHECK] button to check the right and left sides of suction positions.
- Set the right and left sides of suction positions so that O-rings of the standby roller (indicated by arrows in picture) are located at the convergent point of the suction block (boundary of flat surface).
- Touch the [NON PRINT CHECK] button again to check the change.

Upper and lower positions

To set the suction positions (upper and lower sides), touch the [ADJUST] button -> [LABEL APPLICATOR] button -> [POS.] tab. For No.1 and No.2 machines, set the upper and lower sides of the suction positions.

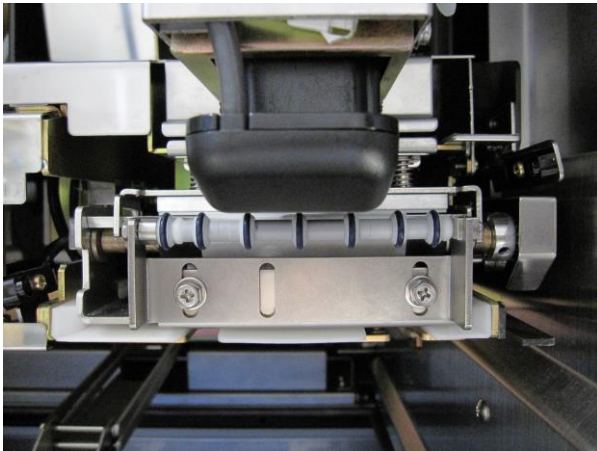

Select the [NON PRINT CHECK] button to check the upper and lower sides of suction positions. Adjust to make the bottom of suction block slightly come in contact with top of O-rings. Change (enter) the set value so that the position becomes 0.5 mm lower from the position in which O-ring is contacted (mechanical side of block slides 0.5 mm, and the block comes in contact further with O-rings)

Note:

If the upper and lower sides of the suction positions are not set properly, the suction errors occur by various causes such as a drop of the power of absorption of applicator or the strong imposition of the label to a standby roller. (see Figure 3).

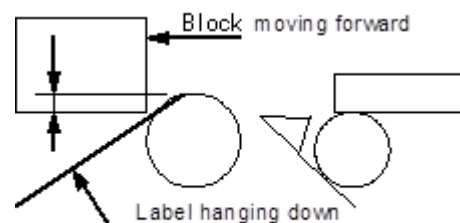
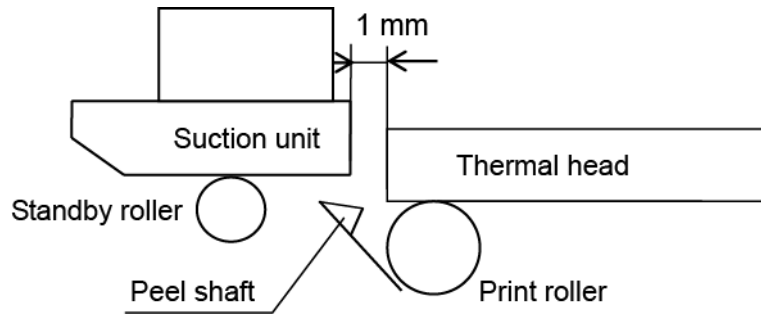

Figure 3: When upper and lower sides of suction positions are set too low

Front and back positions

Set the interval at 1 mm between the printer head bracket and the back side of suction unit.

Check for No.1 and No.2 machines.



2.2.2.4 Automatically adjusting the suction position using natural label size

If the natural size of the issued label exceeds 80mm, the applicator's label suction position will automatically change before operations to in front (positive along the Y axis) for both 0° and -90° to assure labeling accuracy.

Operations are the same in adjustment mode, so when adjusting the positions front and back of an applicator that uses the relevant long labels, adjust using a value “2mm + A (10mm)” added to the amount of change in the normal adjustment position.

With mount

Value of A

Labeling orientation	Label size
	27[mm] to [60[mm] max.
0°	—
-90°	—

*As the specifications state a label size of 60mm max., it is not necessary to change the suction position.

Without mount

Value of A

Labeling orientation	Label size	
	27[mm] to [60[mm] max.	Greater than 80[mm] to 105[mm]
0°	—	10mm
-90°	—	10mm

To improve labeling accuracy, wait for suction at a position +10mm in front of the normal adjustment value (2mm) from the peeling shaft for both 0° and -90°.

Note: If the basic label format that is created exceeds 80mm, the test mode suction check position will also be +10mm in front.

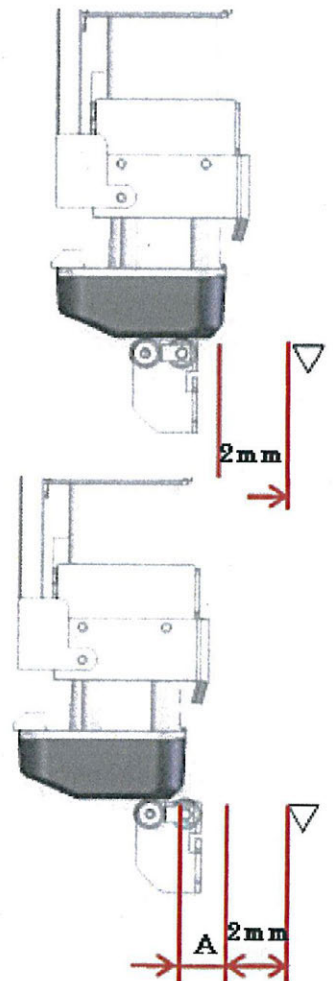

2.2.2.5 Adjusting the paste position

Touch the [ADJUST] button -> [LABEL APPLICATOR] button -> [POS.] tab to adjust the standard paste position of No.1, and No.2 machines.

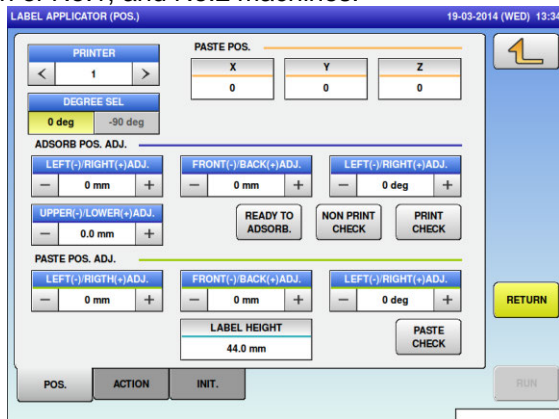

«Horizontal standard paste position at 0 degree»

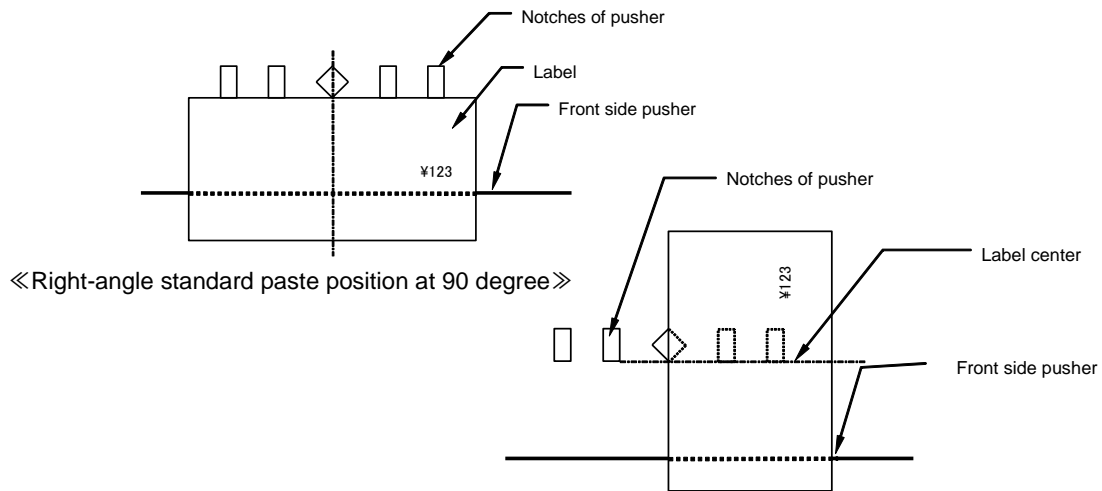

2.2.3 Feeder Unit

2.2.3.1 Adjusting the front feeder origin point

Adjust the position of the front feeder pinch in the following order.

1. Adjust the front feeder origin point.
2. Adjust the position of the insert plate notches and the front feeder pinch. (See the section of the delivery unit.)
3. Adjust the position of the insert plate notches and the rear feeder pinch. (See the section of the delivery unit.)

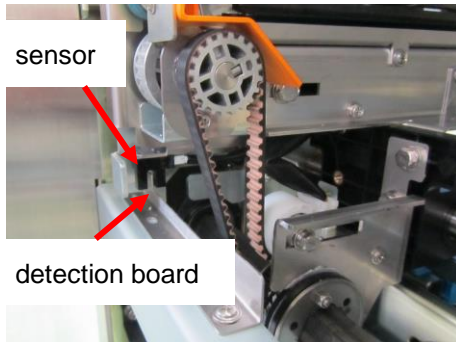

The detection board and the sensor for adjusting the front feeder origin point

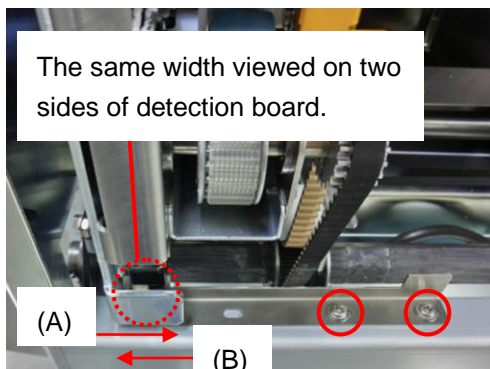

■ Adjusting front feeder origin point

When more than 450 mm wide film is used for continuous wrapping, adjust this origin point.

Touch [TEST MODE] -> [FRONT FEEDER MOVE] to adjust the detection board so that the move (A) (front to back) and move (B) (back to front) are met in the same position. Adjust the position with the two screws.

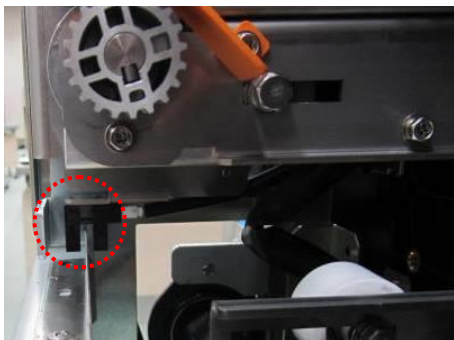

From the side view, check that the detection board is located in the center of the sensor.

2.2.3.2 Film Conveyance Operation Check

- The solenoid for the belt presser operates as described below.
 - The solenoid is OFF when the film is transported. (The belt presser is at the lower position.)
 - After the film conveyance is completed (when wrapping), the solenoid is ON. (The belt presser is at the upper position.)
 - When the film is loaded or removed, or when the return operation is executed, the solenoid is ON. (The belt presser is at the upper position.)
 - When executing clamp operations on the Unit Action screen in the Adjustment mode, the solenoid for belt presser repeats ON and OFF.

- Check the following items when defective film conveyance has occurred.
 - Is the setting of film width correct?
 - Is the film roll inserted in the correct direction?
 - Is the solenoid for pinching appropriately adjusted?
 - Is the position between of the notch of the insertion plate and the feeder pinch correct?
 - Is the film edge inside of the cutter blade?
 - Is the flat belt correctly passed? (Is it passed under the clamp and belt presser?)
 - Is the roll brake appropriately set?
 - Does the holding bar rotate smoothly?
 - Is the position between the insertion plate, the feeder, and the cutter base correct?

- Check the following items when an error indicating that the film has not been supplied occurs though the film has been successfully transported.
 - Check whether the film passage detection sensor is normal or not with the sensor checker.
 - When the film passage detection sensor is normal, install the sensor bracket at the upper-adjustment position and move the detection panel close to the film conveyance surface. (The sensor bracket is installed at the upper-adjustment position at the time of shipping.)

- Check the following items in case of failure to set the film.
 - Is the setting of film width correct?
 - Is the film roll inserted in the correct direction?
 - Is the film type selected correctly?
 - Has trimming been performed when setting the film?
 - Is the film hung within the range of the film hanging range seal?

2.2.3.3 Countermeasures to "Insertion open/close is not set" errors

If used with no sag in the movable parts of the harness for the insertion open/close detection sensor, broken wires may occur easily in the areas secured by bundled bands in the harness.

■ Sensor replacement procedure

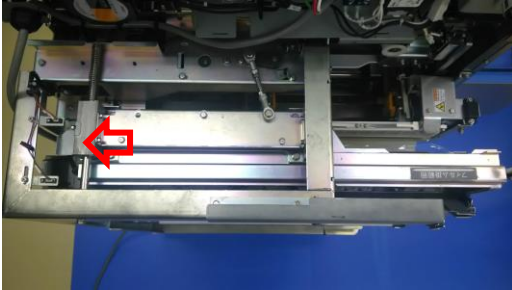

1. The sensor harness connector is housed inside the stay for the insertion unit. Further, the remaining cable can be pushed inside from the back.

When removing the harness, first pull out only the cable that has been pushed in from the back.



2. Pull the harness from the front, and remove the connector that comes out.



3. Set the insertion unit to the same angle as during lower film feed.

Note:

Mount with a little amount of sag at the position where the harness is most taut.



4. Use bundling bands to secure the harness so that it does not move to the D cut position on the shaft.

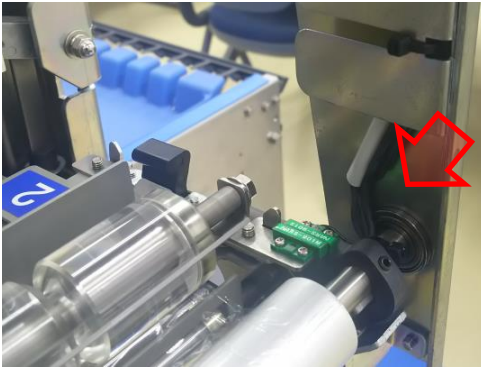

5. Create sufficient sag in the harness, and use bundling bands to secure the harness to the bracket.

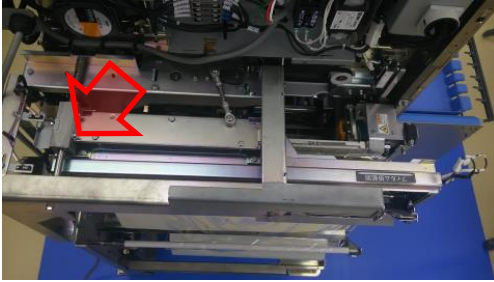

6. Connect the harness, and pull the cable from the back.



7. Fold up the cable as shown in the diagram on the left, and push the harness into the stay.

Note:

Forcefully pushing the cable in from the front may disconnect the harness from the connector, and the connector will be pulled free on the inside.

Note: After mounting the sensor, check the following items.

- Make sure that the harness is not being pulled at the lower film feed position
(If hanging 1, check the upper film feed position.)
- Make sure that the harness does not rub strongly against or catch on other parts when the insertion unit rotates from the lower film feed position to the upper film loading position.

2.2.4 Delivery Unit

2.2.4.1 Adjusting the height of the delivery unit

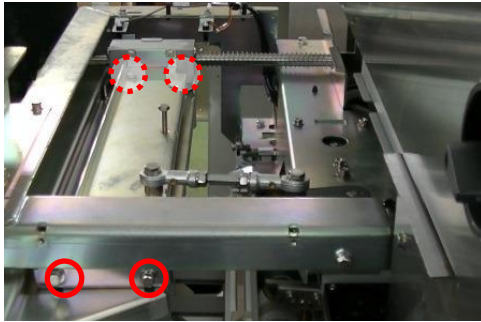

1. Loosen the screws on both ends.
After loosen the screws, delivery unit can be moved in the up/down positions.

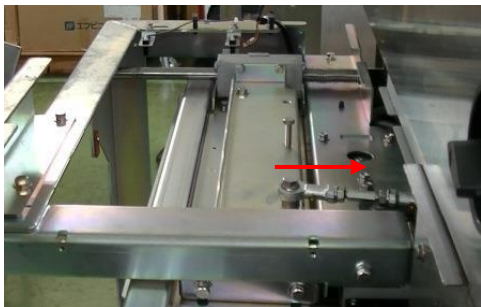

2. Push in the delivery unit.

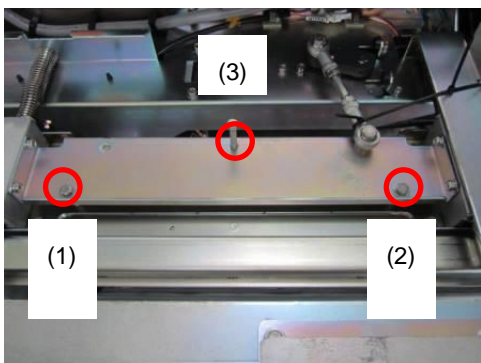

3. Adjust the height using three jack screws.
In the positions of (1) and (2) shown in the picture, perform the parallel adjustment of height and front/back positions.
In the position of (3), adjust right/left positions.

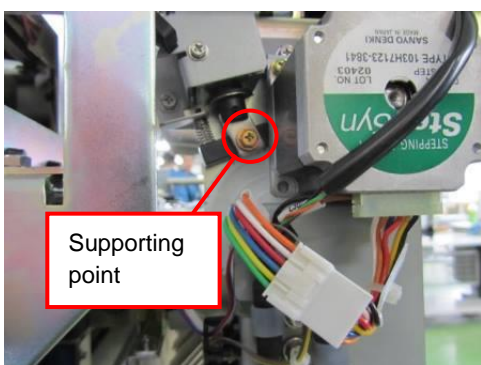

■ Performing fine adjustment for delivery unit

Perform fine adjustment for the delivery unit to set the insert plate (lower side) horizontally by moving the teeth of gear. If it does not become horizontal, slightly move the fixed position of the supporting point.

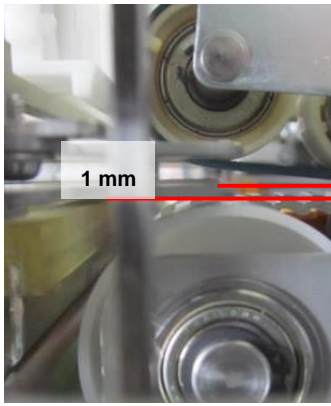

■ **Referential value for height adjustment**

Adjust to set the interval at 1 mm between the insert plate (lower side) and the feeder belt slave roller.

Check the other side roller.

2.2.4.2 Adjusting the height of the cutter saucer

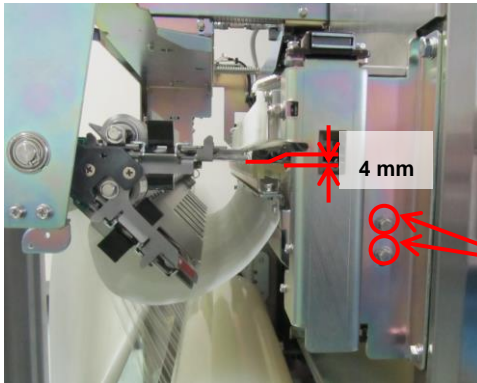

Adjust the cutter saucer to set the interval at 4 mm between the insert plate (lower side) and the cutter saucer in standby state.

Bolts for cutter saucer in standby state

2.2.4.3 Adjusting the origin point of the delivery unit

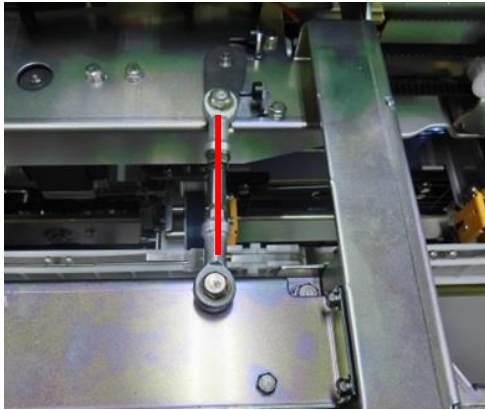

Shift the delivery unit to the position in which the rod end becomes straight.

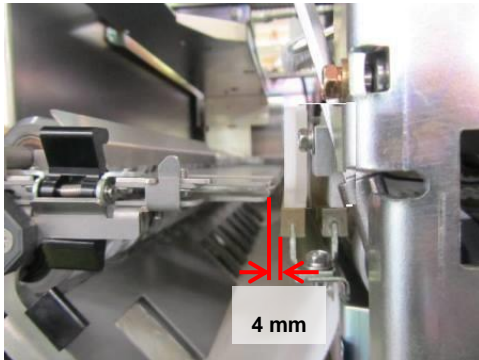

Adjust the rod end length to set the interval at 4 mm between the cutter saucer and the left side of the insert plate forefront.

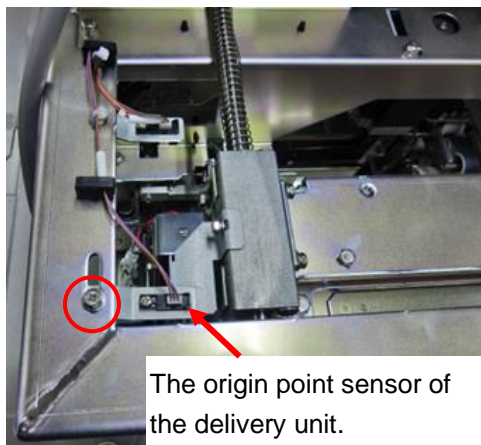

Loosen the screws indicated in the circle in the picture, adjust the position of the delivery unit origin point sensor to make the rod end straight at the origin point. After returning to its origin point, make sure that the distance between the cutter saucer and left side of the insert plate forefront is 4 mm.

2.2.4.4 Adjusting the position of the insert plate notches and the front feeder pinch

Adjust the position of the insert plate notches and the front feeder pinch in the following order.

1. Adjust the front feeder origin point. (See the section of the feeder unit.)
2. Adjust the position of the insert plate notches and the front feeder pinch.
3. Adjust the position of the insert plate notches and the rear feeder pinch. (See the next section.)

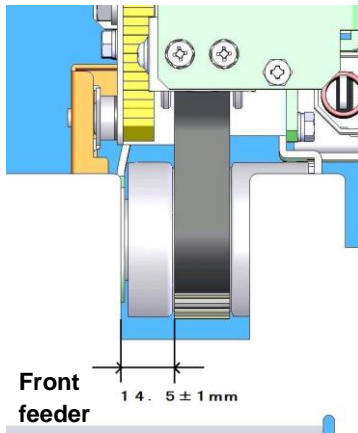

After returning to its origin point, measure the interval between the insert plate notches and front feeder belt. If it is not within the range as indicated in the figure, adjust the position of the insert plate notches.

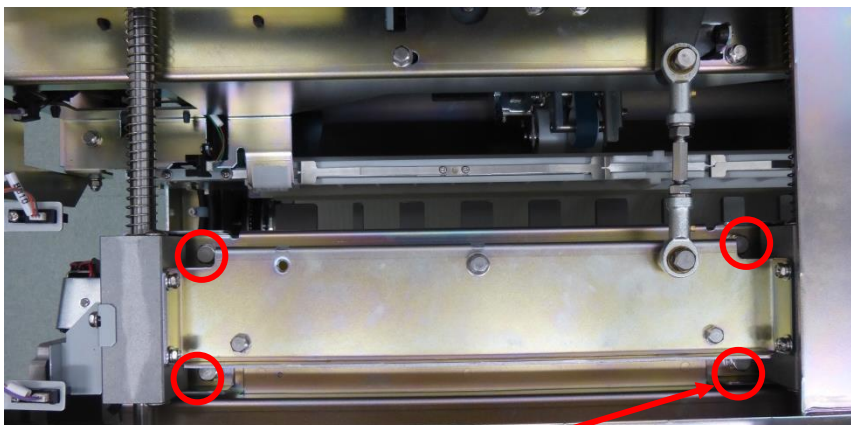

■ Adjusting the position of the insert plate notches

Move the insert plate by loosening the bolts indicated in the 4 circles in the picture. Fix the insert plate to be set at the specified interval between the insert plate notches and feeder belt.



Long hole for adjustment

2.2.4.5 Adjusting the position of the insert plate notches and the rear feeder pinch.

Adjust the position of the insert plate notches and the rear feeder pinch in the following order.

1. Adjust the front feeder origin point. (See the section of the feeder unit.)
2. Adjust the position of the insert plate notches and the front feeder pinch. (See the preceding section.)
3. Adjust the position of the insert plate notches and the rear feeder pinch.

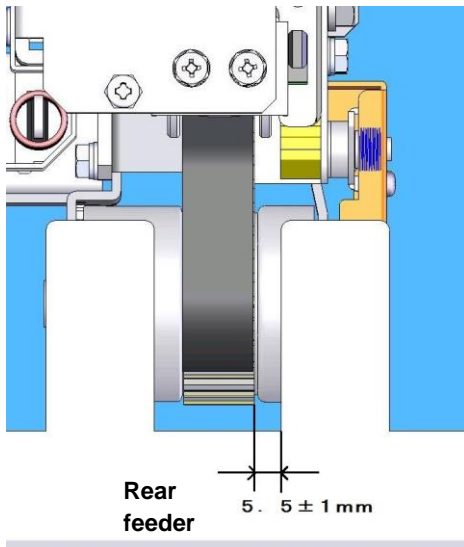

After adjusting the front feeder pinch position, measure the interval between the insert plate notches and rear feeder belt in the following order.

If it is not within the range as indicated in the figure, adjust the detection board position of film width.

- ① Press the emergency stop switch.
- ② Move the rear feeder forward.
- ③ Release the emergency stop and press the [RETURN] button.
- ④ After the rear feeder is shifted to the front feeder side, it stops in the detection board position of film width.
- ⑤ Check the interval between the notches and pinch.

If it is outside range, adjust the installation position of the detection board of film width.



■ Adjusting the detection board position of film width.

Move the detection board of film width by loosening the bolts indicated in the 2 circles in the picture.

Fix the insert plate to be set at the specified interval between the insert plate notches and feeder belt.

2.2.4.6 Adjusting the pinch

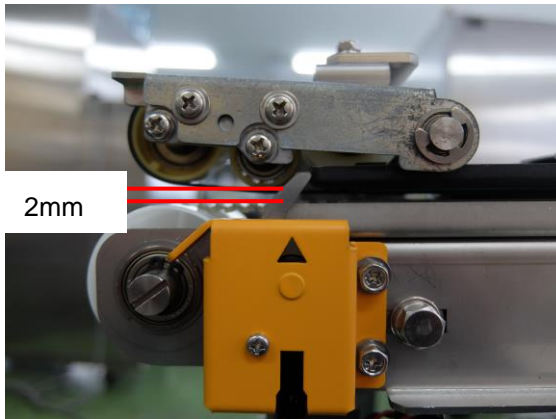

Compared to the conventional machines, the WM-AI uses strong suction power solenoid and the strong return spring for the film pinch. Therefore, the film pinching part may be released during film conveyance depending on the solenoid's adjustment position. Tightening the solenoid adjustment when the film pinching part is released worsens the condition of the pinch. Be sure to perform adjustment and check according to the procedure below.



In the adjustment mode for maintenance, press, perform adjustment via "UNIT ACTION" -> "WRAP" tab screen by following the procedures described below.

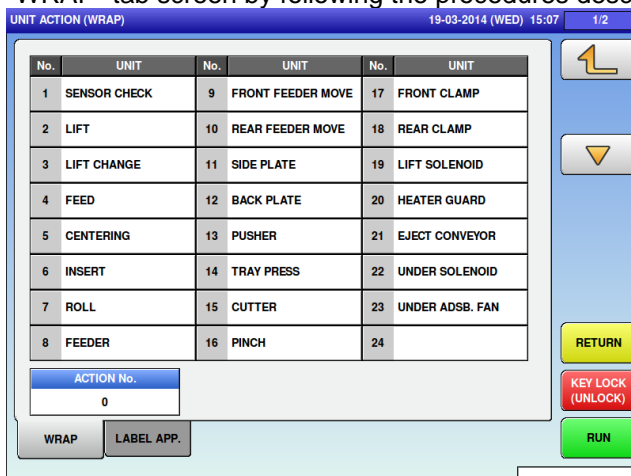

1. Perform operation check according to "16 PINCH ADJUSTMENT". Put a normal copy paper at the point shown in the figure below and pull it by using the push-pull gauge. Perform solenoid adjustment such that the force when the film pinching part is closed becomes "1 to 2.2kgf" by using the screws for adjusting the solenoid position.

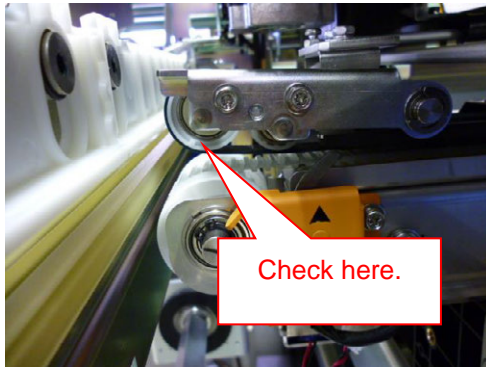

2. Confirm that the film pinching part will not be released during film conveyance after performing about 30 times of film feeding operations by use of "27 FILM FEED".



Make sure to remove the film before performing [UNIT ACTION] of ADJUST mode.

The holding power may vary by approximately 0.5 [kgf] between the peak and valley of the feeder belt. Avoid the pinching power from becoming 1.0 [kgf] or less when the film is pinched at the valley of which pinching power is minimum.

2.2.4.7 Adjusting the clamp

Clamp is used for holding a film during wrapping trays. Whether the wrapping is successful or not depends on the timing when the film is released by the clamp.

There are 3 clamps in each of rear feeder and front feeder, and are located as shown in the figure below. The right and left sides of each clamp must be moved at the same timing (up to 10 ms timing difference acceptable).

Make sure that the film is not come off when the film is stretched at the maximum.

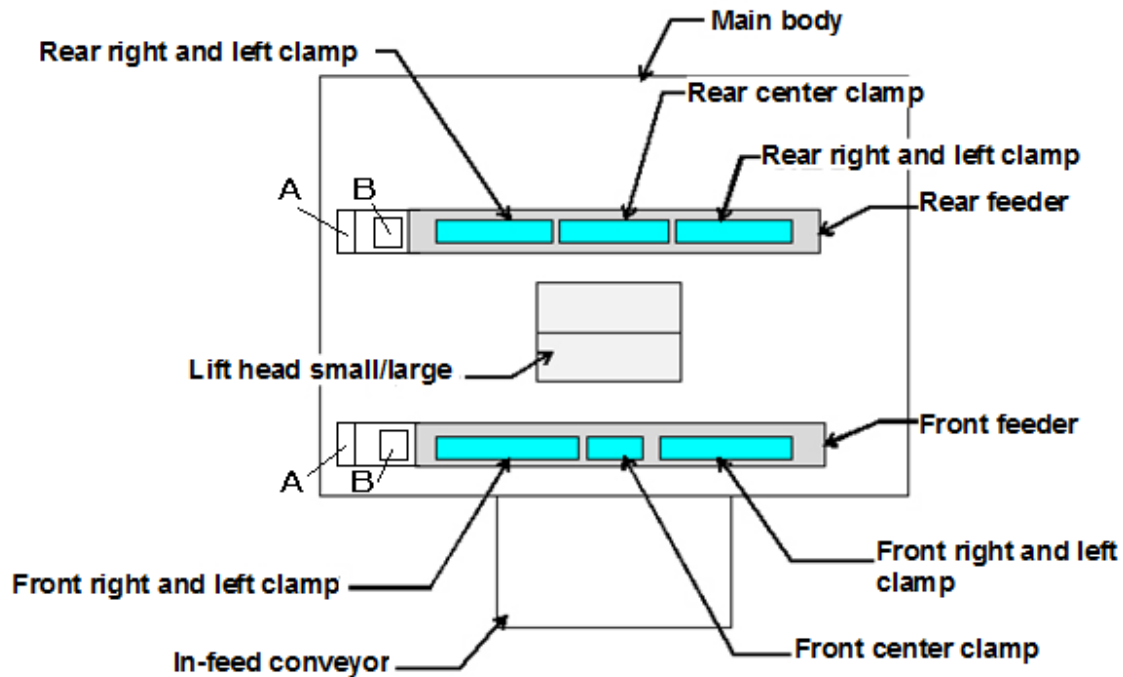

Feeder unit (top view)

2.2.4.8 Adjusting the meandering flat belt

Perform operation check on [8 FEEDER] in [UNIT ACTION].

Make this adjustment if the flat belt is meandering.

Use the two screws located on the surface of the flat belt for adjusting the flat belt.



CAUTION

Be sure to adjust the belt so that the flange of the idler pulley and flat belt do not contact each other during forward operation (film conveyance direction). Be sure to check that the flange of the idler pulley and flat belt do not strongly contact each other (must not be deformed) during reverse operation.

CAUTION

There is also a location for meander adjustment at the film over side.

2.2.5 In-feed Unit

2.2.5.1 Checking the origin point return of the conveyance bar

When replacing the supporter rail or the guide pusher, check the origin return of the infeed bar of the infeed conveyor unit.

(This is to check if the infeed conveyor unit and supporter rail are correctly mounted and the conveyance bar is not interfered.)

Perform checks after completing adjustment of each part.

- In normal mode, press the return button and then push the emergency stop switch button.
- Push the infeed conveyance bar (No.24 in the exploded view) into the rear of the machine until it is interfered with the lift head unit.
- Press the return button.
- Check that bar is returned to the origin without an error. If an error occurs check that the guide pusher (No.21 in the exploded view) and supporter rail (No.35 and 36 in the exploded view) are closely attached and mounted.

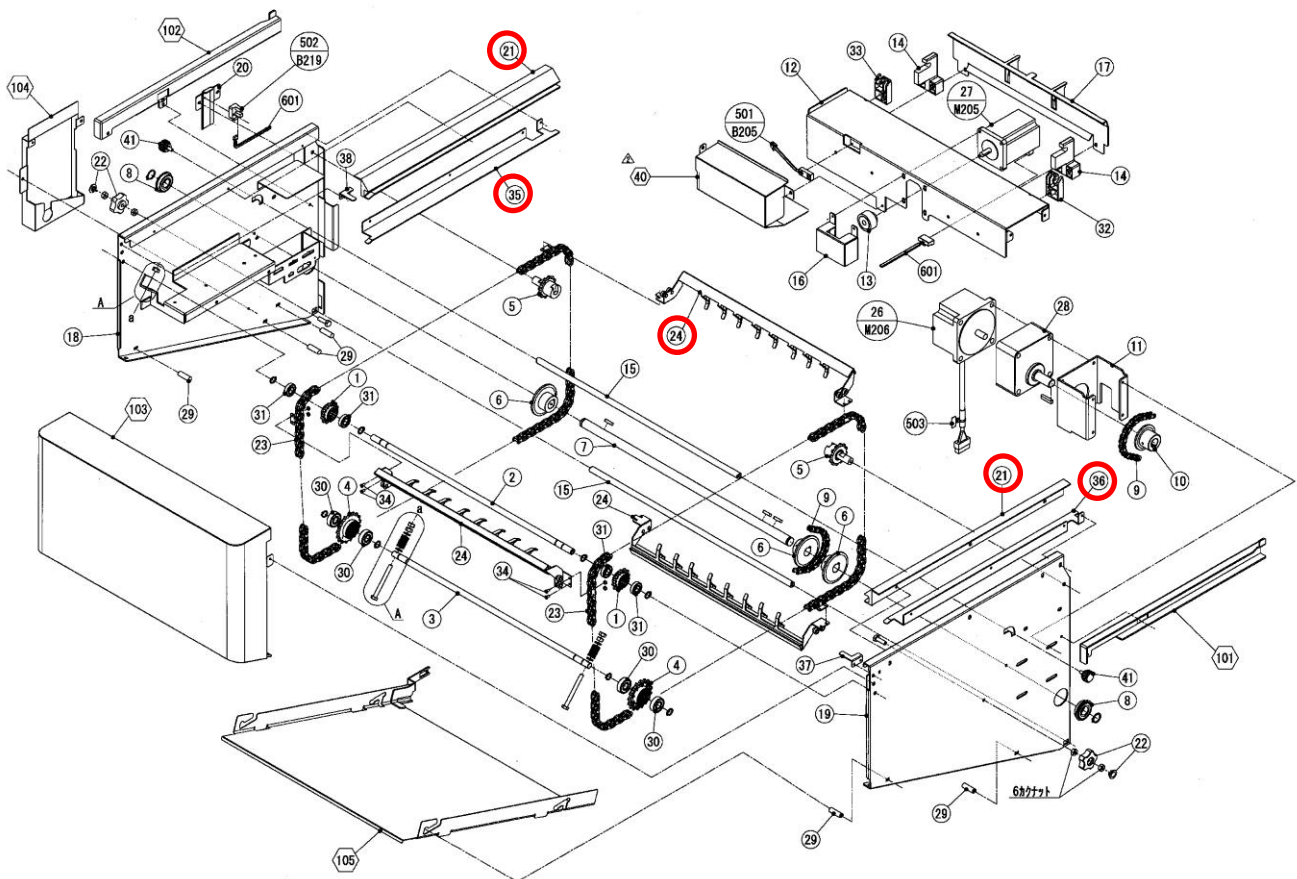

Exploded view

2.2.6 Camera Unit

2.2.6.1 Adjusting the installation position of detection camera

[Items to be adjusted] Installation position of camera, gradient of camera bracket

[How to adjust and check]

1. Fix the camera installation bracket to be located in the center of the hole.

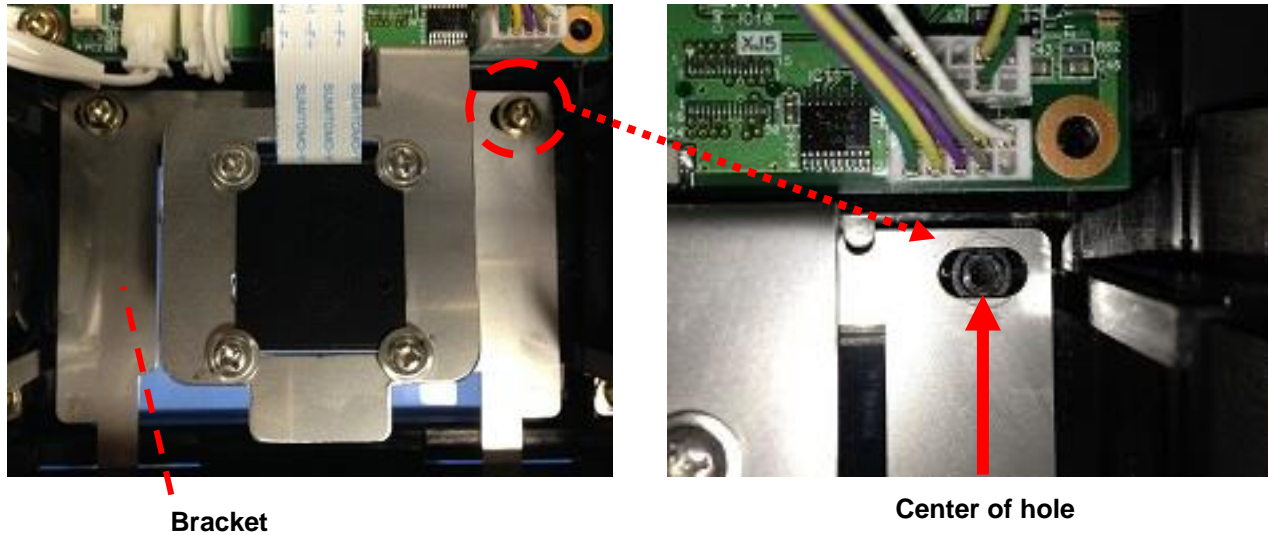

CAMERA UNIT STANDARD 100-004-6558-00

Use TP screws (M3-6 SUS) to fix the CAMERA: CMOS: COLLAR to the BRACKET: CAMERA. Tightening torque should be M3 standard torque (0.6Nm).

Check that BRACKET: CAMERA is not on the PLATE: FILTER: CAMERA as shown in Figure1.

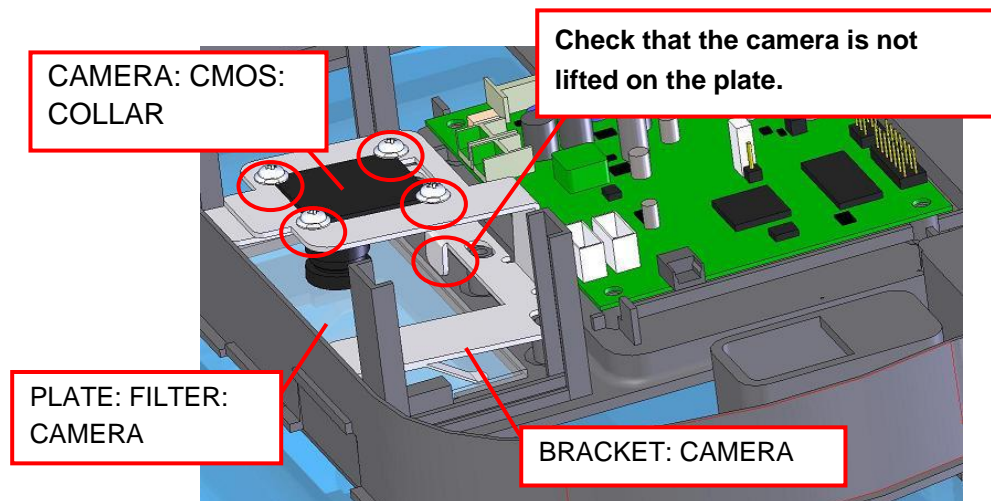

Figure 1

2. Adjust the camera after mounting the cover.

- On the [CAMERA (ADJUSTMENT)] screen, display [DISPLAY MODE <WHOLE>] of ADJUST mode to check that the following four points are satisfied.

◆ In [DISPLAY MODE <MAGNIFICATION>], check that the standard adjustment line (white line) in the width direction is not broken.

→ If the line is broken, perform step 4 “Length direction offset”.

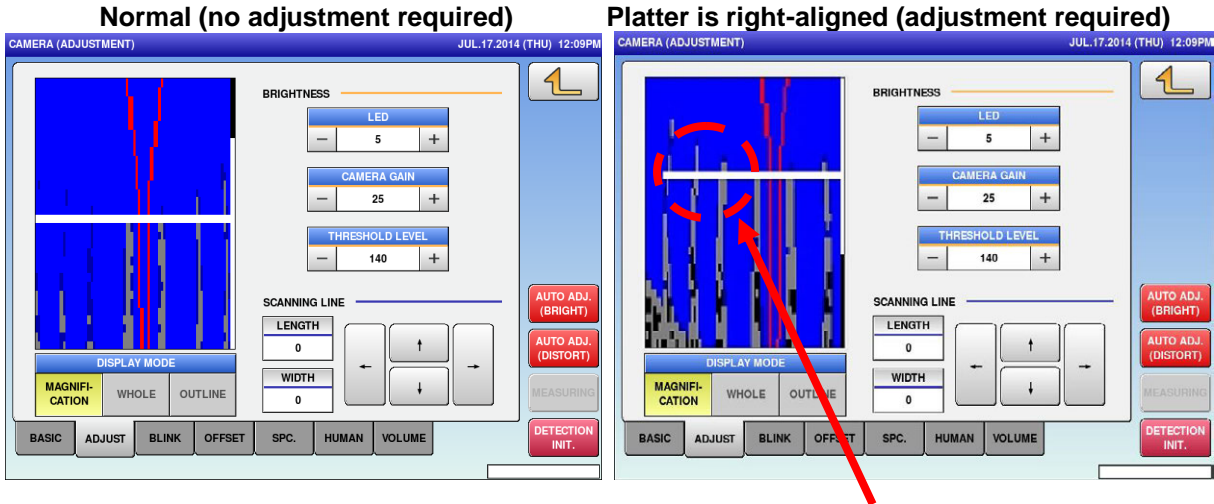

Standard adjustment line is broken

◆ In [DISPLAY MODE <MAGNIFICATION>], check that the standard adjustment line (white line) in the width direction is not extremely aligned to the upper or lower side. (An adjustment line be far from the top and bottom indication frames more than 25 mm (actual value on the screen)).

→ If the line is extremely aligned to the upper or lower side, perform step 5 “Width direction offset”.

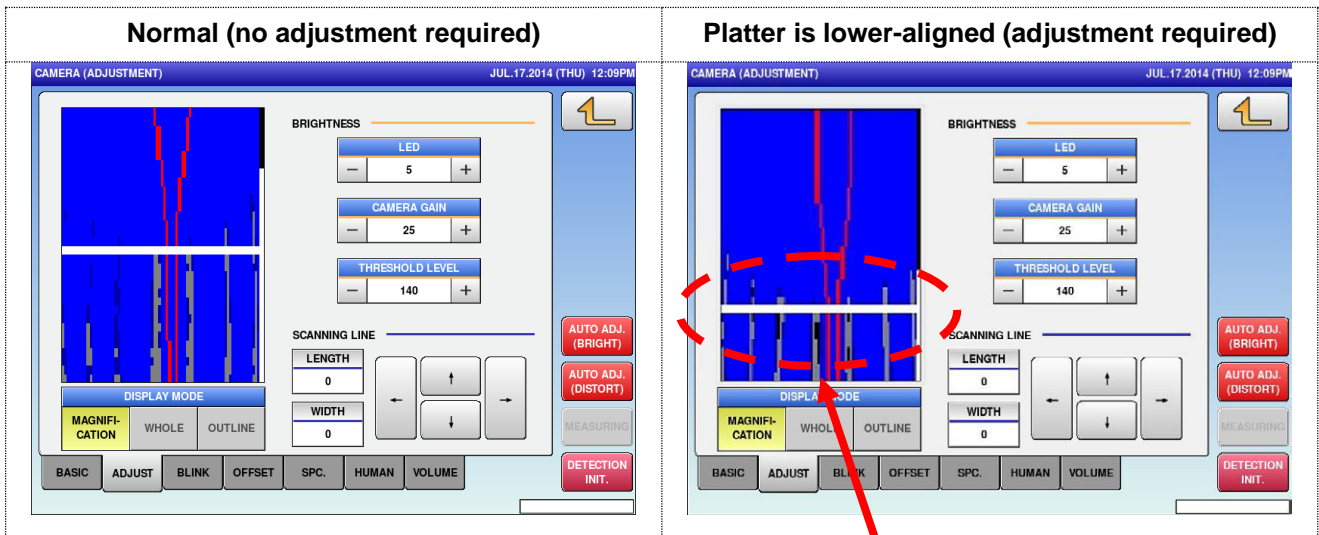

Standard adjustment line is extremely aligned to the lower side

- ◆ In [DISPLAY MODE <WHOLE>], check that the platter is displayed around in the center.
 - If the platter is aligned to the right or left side, perform step 4 “Length direction offset”.
 - If the platter is aligned to the upper or lower side, perform step 5 “Width direction offset”.

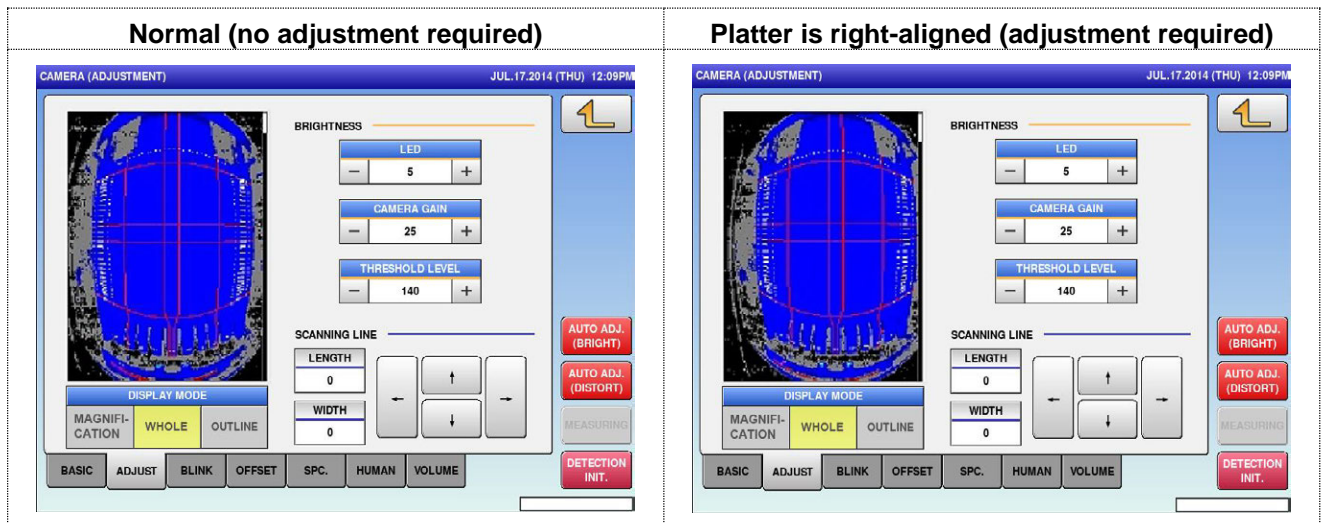

- ◆ In [DISPLAY MODE <WHOLE>], check that the blue seal line of the in-feed frame unit is completely displayed.
 - *Make this adjustment when detecting a tray of more than 50 mm height.
 - If the blue seal line of the in-feed frame unit is not completely displayed and is broken, perform step 5 “Width direction offset”.

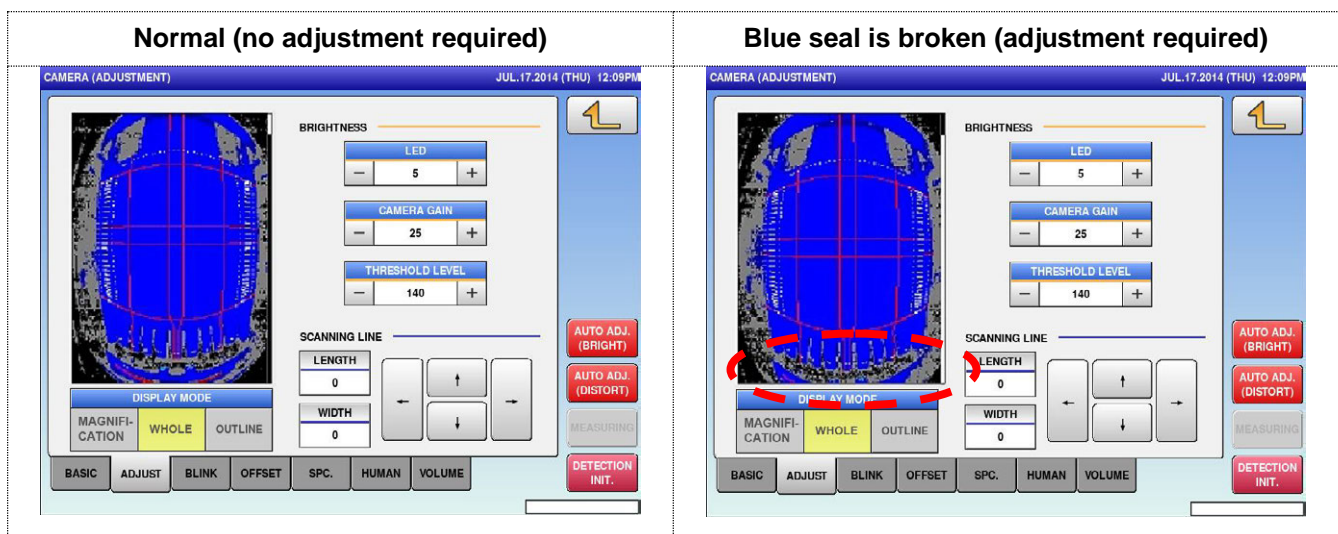

4. Length direction offset
 - Display the entire platter by touching the [DISPLAY MODE <WHOLE>] button of ADJUST mode.
 - To the display window of the detection image shown in the figure above, adjust the inclination of the bracket or move the camera installation bracket to the side on which the platter is aligned.
 - Adjust the camera and check step 3.

5. Width direction offset
 - Display the entire platter by touching the [DISPLAY MODE <WHOLE>] button of ADJUST mode.
 - To the display window of the detection image shown in the figure above, adjust the inclination of the camera installation bracket so that the platter is placed in the center.
 - Adjust the camera and check step 3.

2.2.7 Lift Unit

2.2.7.1 Adjusting the lift upper position

At the upper lift position, the relationship of the height between the lift head and rear wrapping plate needs to be adjusted.

To check this, touch the [ADJUST] button -> [WRAP] button -> [LIFT] tab. The lift goes up by touching the [UPPER LIFT POS.] button on the screen.

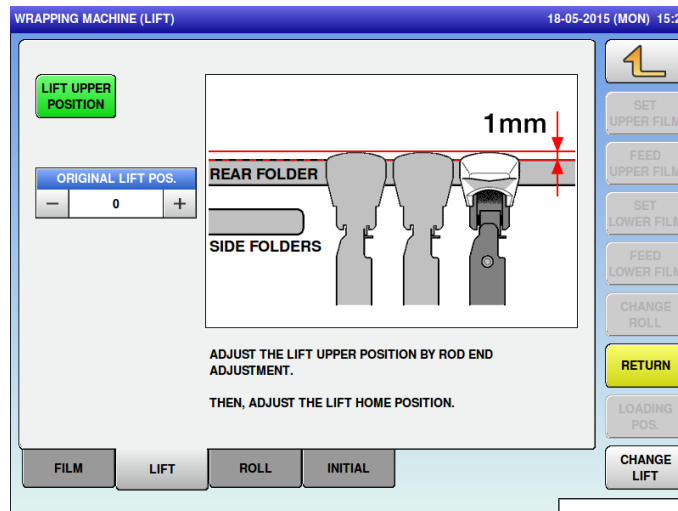

As the side wrapping plate and the rear wrapping plate can be moved by hand, pull the rear wrapping plate toward you, and adjust "rod end" so that the height of lift head is set 1 mm higher than the rear wrapping plate. The rod end can be found by opening the rear cover of the main machine body. After the lift upper position is completely adjusted, adjust any other positions.

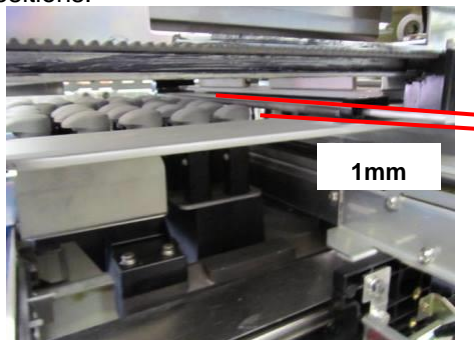

CAUTION

If the lift upper position is adjusted more than 1 mm higher than the rear wrapping plate, the lift head will be broken during operation.

When centering the side wrapping plate, if outside of the side wrapping plate is located inside of the lift head width, the lift head that has been felled will rise up, and the side wrapping plate cannot return to its original position. In this case, touch the [RETURN] button.

2.2.7.2 Adjusting the lift origin point

To check this, touch the [ADJUST] button -> [WRAP] button -> [LIFT] tab. The lift goes down by touching the [ORIGINAL LIFT POS.] button on the screen. Adjust the heights of the weighing platter, centering conveyor, infeed section (connection plate) and lift head to be within ± 0.5 mm.

And adjust the tip of the connection plate to be higher than the lift head.

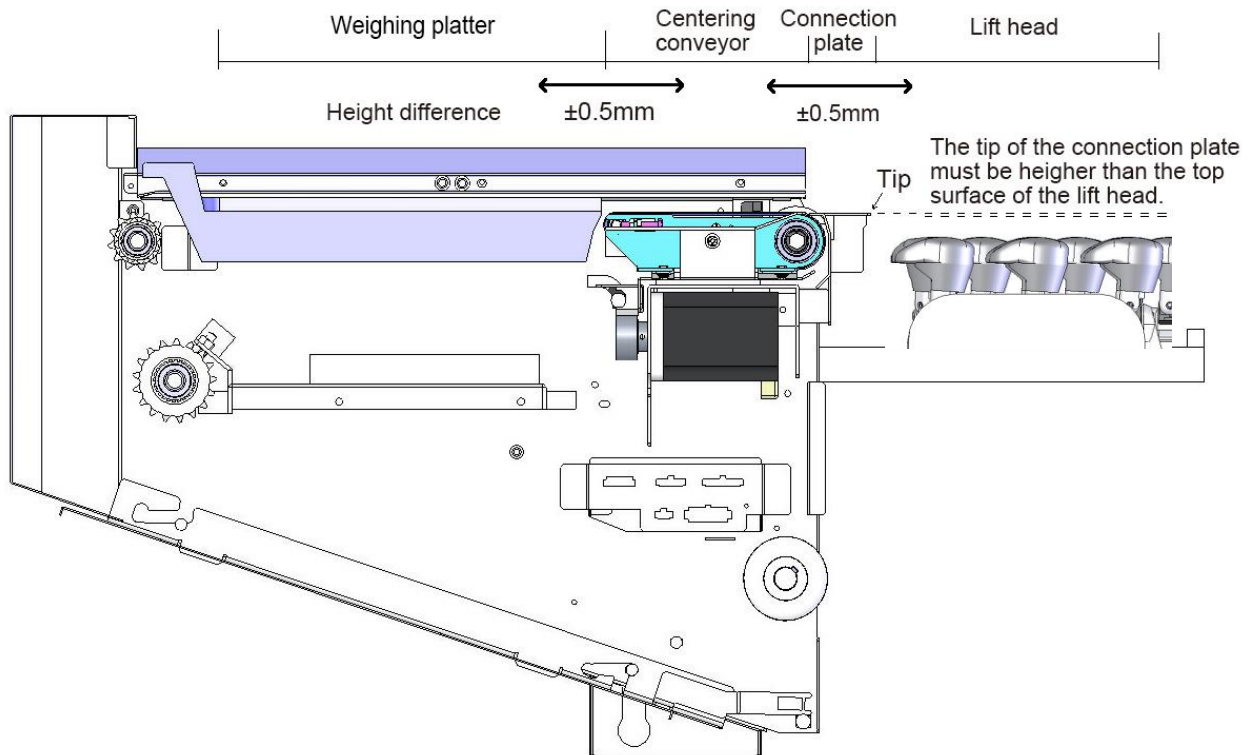

If the lift lower position is adjusted, changing between the large and small lift also needs to be adjusted.

[Adjustment position]

Adjust the lift origin height such that the surface between the top of the centering conveyor and top of the lift head becomes flat (± 0.5 mm). (Figure 1 and 2)

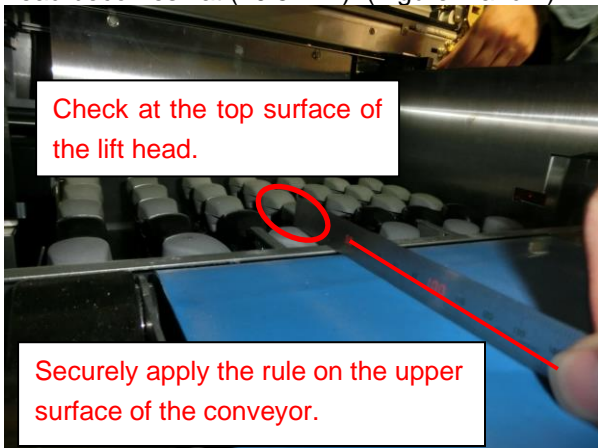

Figure 1



Figure 2

Do not check at the area where the connection plate is extended to the back. (Figure 3, 4, and 5)

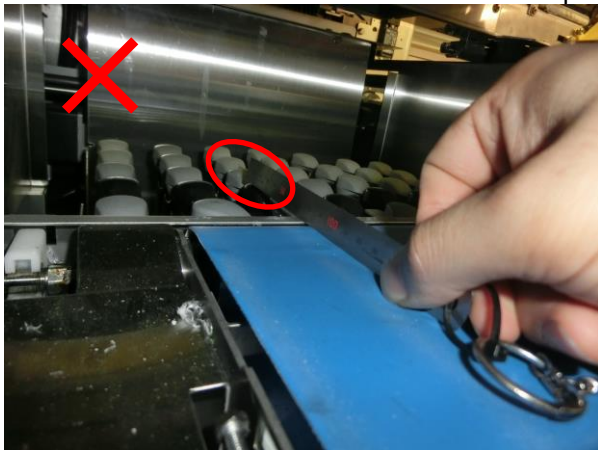

Figure 3

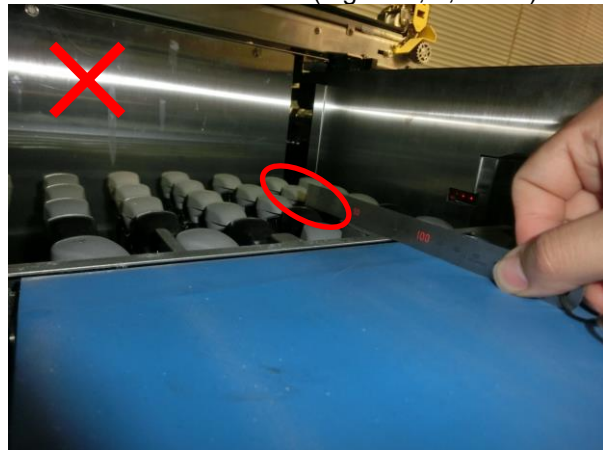

Figure 4

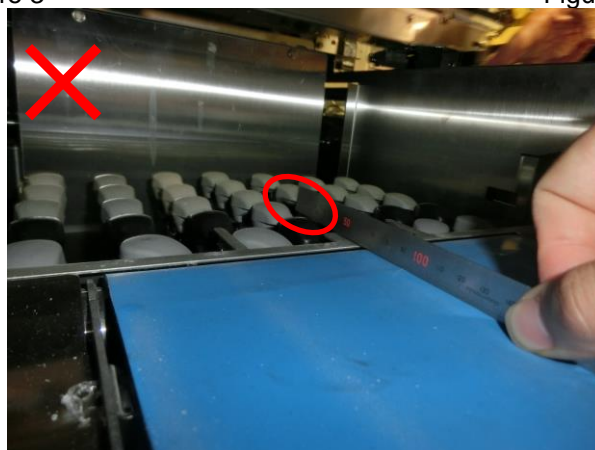

Figure 5

2.2.7.3 Changing between the large and small lift

The lift can be changed between large and small by inserting and removing the changeover latch.

By inserting the changeover latch, both large and small heads go up.

By removing the changeover latch, only the small head goes up.

The latch is inserted and removed by the changeover solenoid.

When the solenoid is excited, latch pawl is hooked and the large lift becomes operational.

When the solenoid is not excited, the latch pawl is released and the small lift becomes operational.

The solenoid switches the large or small lift to use according to the [change lift] setting of the tray master. The unit can be found by removing the rear cover of the main machine body.

To check the lift change operation, touch the [ADJUST] button -> [WRAP] button -> [LIFT] tab -> [CHANGE LIFT] button.

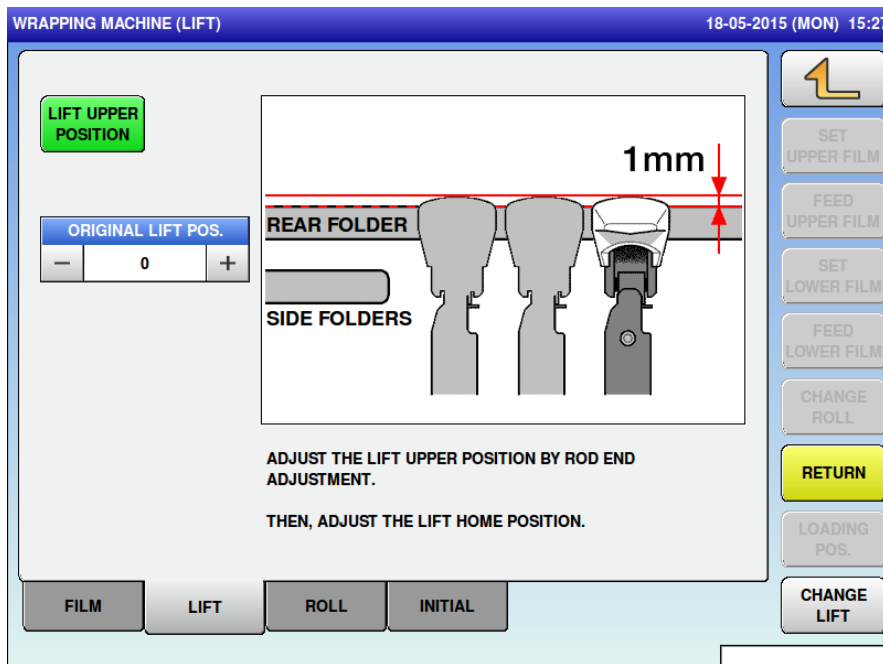

2.2.7.4 Checking the gap between connection plate's convex part and lift head, and between the weighing platter and conveyance bar

When the position of the lift unit and the infeed plate changes by replacing the connection plate or loading/unloading the infeed plate, check the following gaps.

1. Gap between the infeed unit connection plate's convex part and lift head
When the lift head is on the infeed position, the gap between the connection plate's convex part and lift head (Pic.1) must be 2 mm (design value is 4.3 mm).

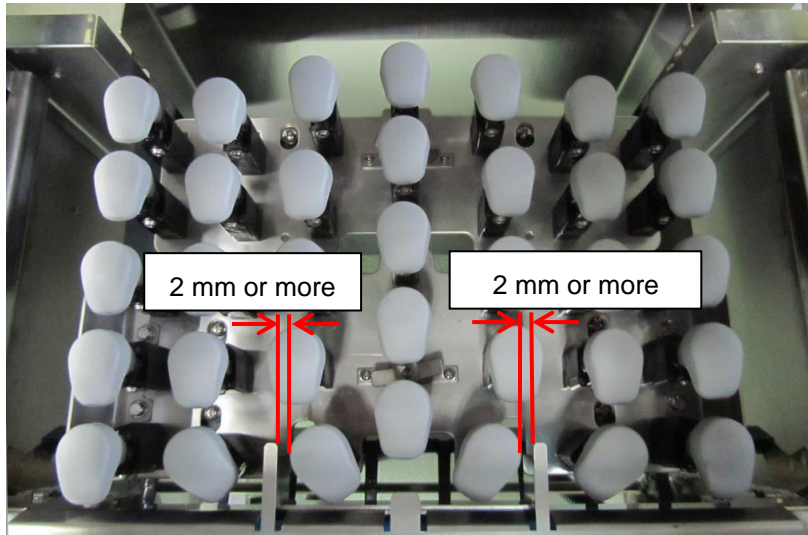

Picture 1: Gap between lift head and convex part of the connection plate

2. Gap between the infeed plate and infeed conveyance bar.
Place the weight of 6kg at the front corner of the weighing platter with the infeed conveyance bar manually moving to the position shown in Picture 2. The gap between the weighing platter and conveyance bar hook must be 1 mm or more. (The design gap with no load is 3 mm. When installing the weight, check the gap placing the weight in the front left corner and the front right corner respectively.

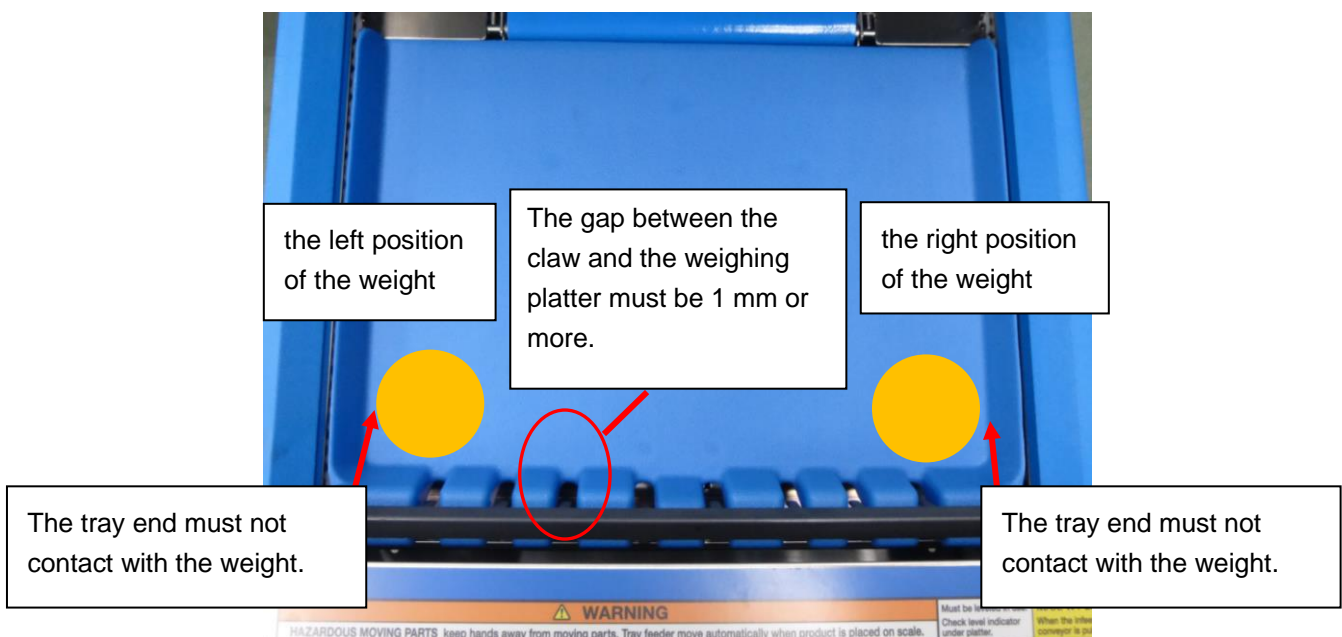

Picture 2: The gap between the weighing platter and infeed conveyance bar, and the position of the weight

2.2.7.5 Adjusting lift switch solenoid

On the maintenance screen, go to "ADJUST MODE" -> "WRAP" -> "LIFT" tab, and then press the "CHANGE LIFT" button to operate lift switching operation.

Push the emergency stop switch button to stop operation before adjustment.

Hold the iron core of the solenoid to align the position of the solenoid to the position where the latch was pushed all the way through the back of the machine. The iron core of the solenoid must reach the bottom.

Move the position of the solenoid from the said position for 0.5 mm in the arrow direction.

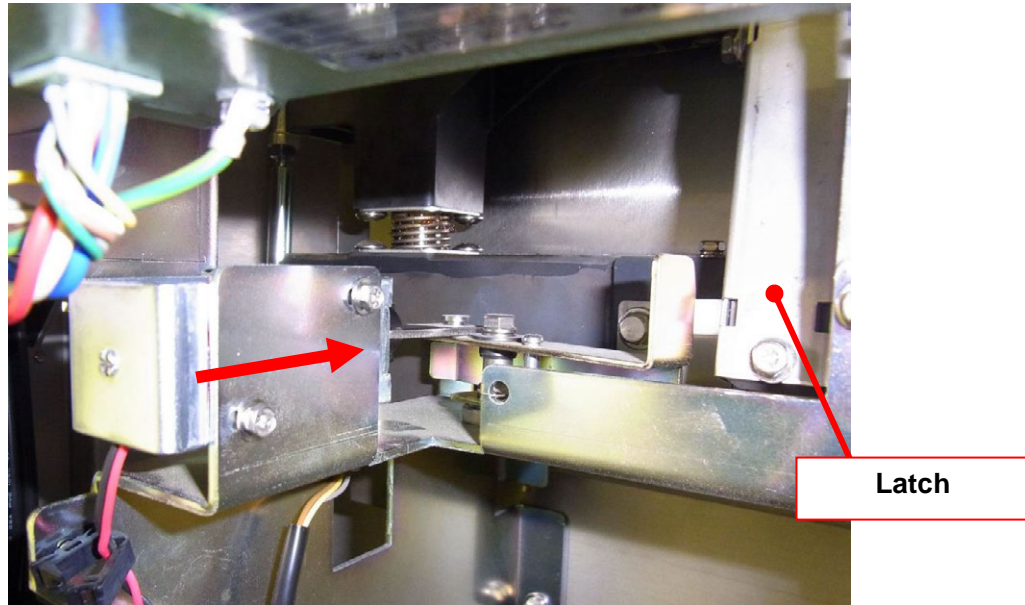

On the maintenance screen, go to "ADJUST MODE" -> "UNIT ACTION (WRAP)" -> "3. LIFT CHANGE" check the lift switching operation and confirm that the hook will not be disengaged.

2.2.7.6 About the Assembling of the lift head connection

This section explains how to adjust the sub-lift head becoming higher than the main lift head when assembled.

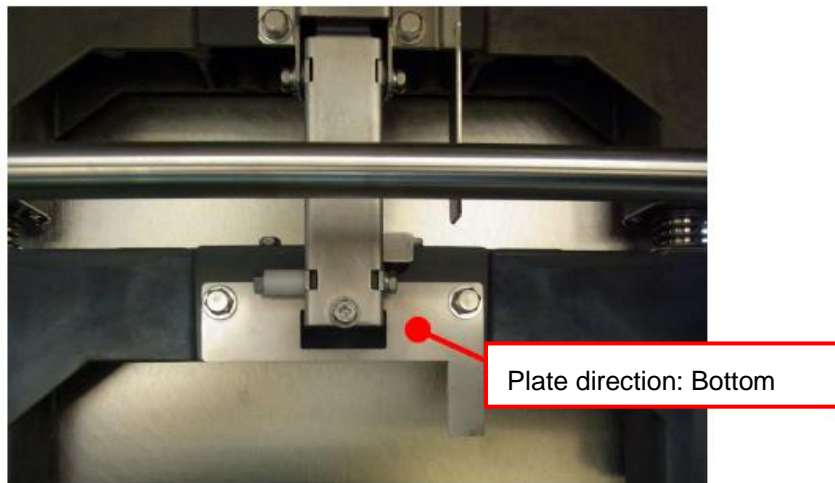
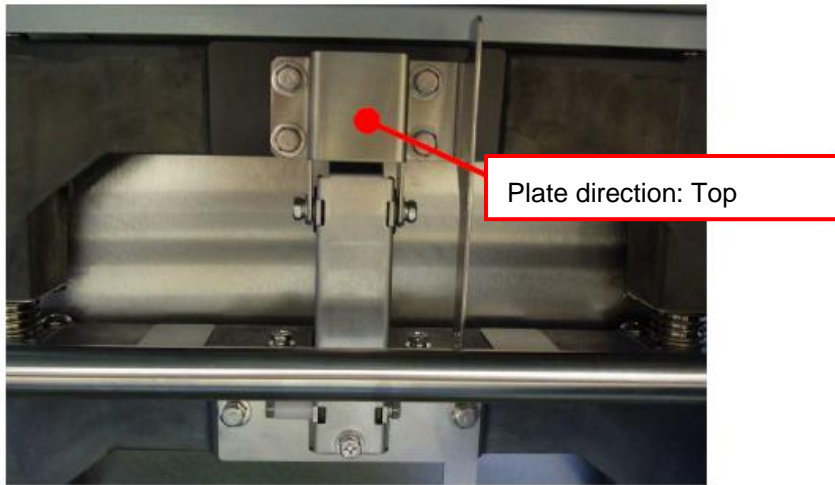

2.2.7.7 About the adjustment of the sensor on the lift

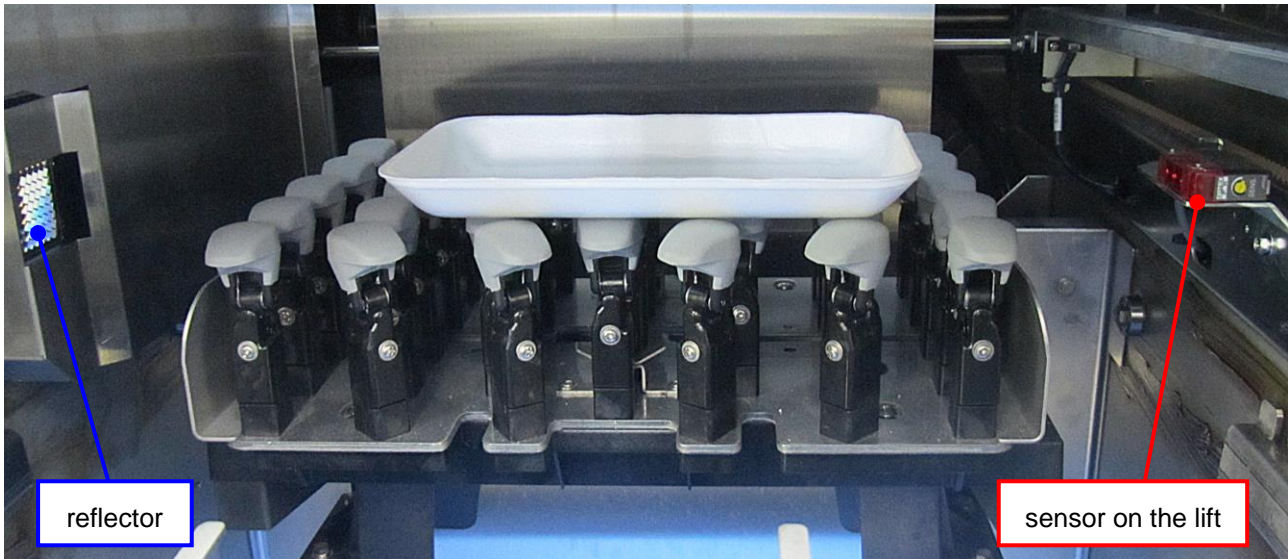

At factory shipment, the sensitivity adjustment the sensor on the lift is adjusted using the GS-20-12C standard tray of the RISUPACK.



Make the sensitivity adjustment the sensor on the lift when a transparent tray or a tray less than 10 mm in height is used.

Sensitivity adjustment of the sensor

Adjust the sensor sensitivity using the tray which has highest transparency of customer's transparent tray.



1. Remove the cover of the sensor.

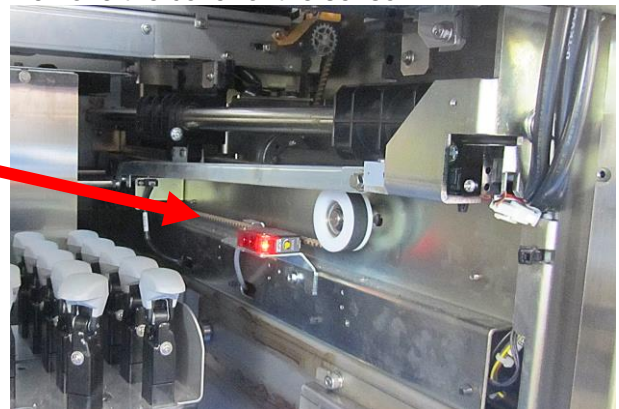

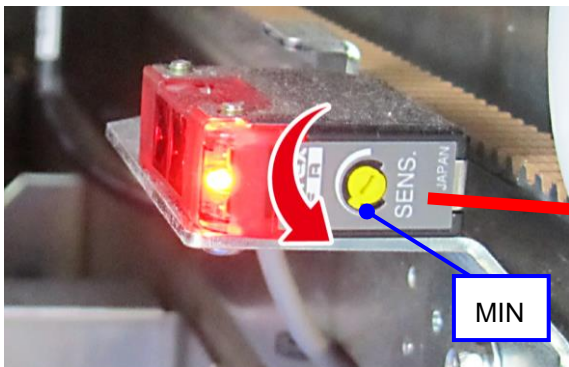
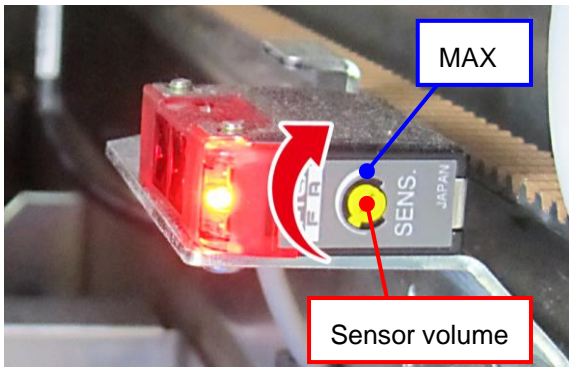

2. Place a high-transparency tray on the lift.

3. Turn the sensor volume to the MAX position.

4. Turn the sensor volume to the MIN position until the sensor's LED is turned off.



5. If the tray surface is not flat and smooth, move and place the tray diagonally to check whether the sensor's LED will be turned on. If the LED turned on, perform the step 4. in the position where the tray is placed.

6. The volume position where the LED is not turned on shall be the position A.

7. With nothing on the lift, turn the sensor volume from the MAX position to the MIN position until the sensor's LED is turned off.

8. The volume position where the LED is turned off shall be the position B.

9. The optimal position occupy an intermediate position between the position A and the position B. Then turn the sensor volume to the optimal position.

Note:

Position B is the minimum volume position that can be detected by the sensor. Therefore, the sensor volume must be set towards the MAX position from the position B.

10. Mount the cover of the sensor.

If the transparent tray does not exist, adjust the sensor sensitivity using customer's lowest tray.

1. Remove the cover of the sensor.
2. Place a lowest tray on the lift.



3. Turn the sensor volume at the MIN position.
4. Turn the sensor volume to the MAX position until the sensor's LED is turned on.
5. The volume position where the LED is turned on shall be the position A. If the LED is not turned on at the MAX position then the position A shall be the MAX position.
6. With nothing on the lift, turn the sensor volume from the MAX position to the MIN position until the sensor's LED is turned off.
7. The volume position where the LED is turned off shall be the position B. If the LED is not turned off at the MIN position then the position B shall be the MIN position.
8. The optimal position occupy an intermediate position between the position A and the position B. Then turn the sensor volume to the optimal position.

Note:

Position B is the minimum volume position that can be detected by the sensor. Therefore, the sensor volume must be set towards the MAX position from the position B.

9. Mount the cover of the sensor.

2.2.7.8 Adjusting the Tray Sliding State

Optional Lift Head (= Shiny Surface) for trays that don't pass lift head smoothly

LF Black 000-125-5245-**

RF Black 000-125-5246-**

L Black 000-125-5247-**

R Black 000-125-5248-**

Recommended Positions at Replacement



Change the 7 lift heads (for small tray) as shown in the photo (Black lift head).

Lift head L

(000-125-5247-**): 3 pcs.

Lift head R

(000-125-5248-**): 3 pcs.

Lift head LF

(000-125-5245-**): 1 pc.

(As of May 2015)

Changing the 1st-row heads to POM heads is minimally-effective because the connection plate exists. However, changing the 2nd-row heads to POM heads is effective. (The head height against the connection plate must be correctly adjusted.)

Note that a tray may slip too much when changing heads at other positions to POM heads.

2.2.7.9 Applying grease to the spring

Applying the grease equivalent of "Shell Alvania Grease S" by Showa Shell Sekiyu to the spring reduces friction and prevents damage.

When replacing the SPRING: COIL: COMPRESSIVE of No.30 on the exploded view shown below, apply Alvania grease on both hooks.

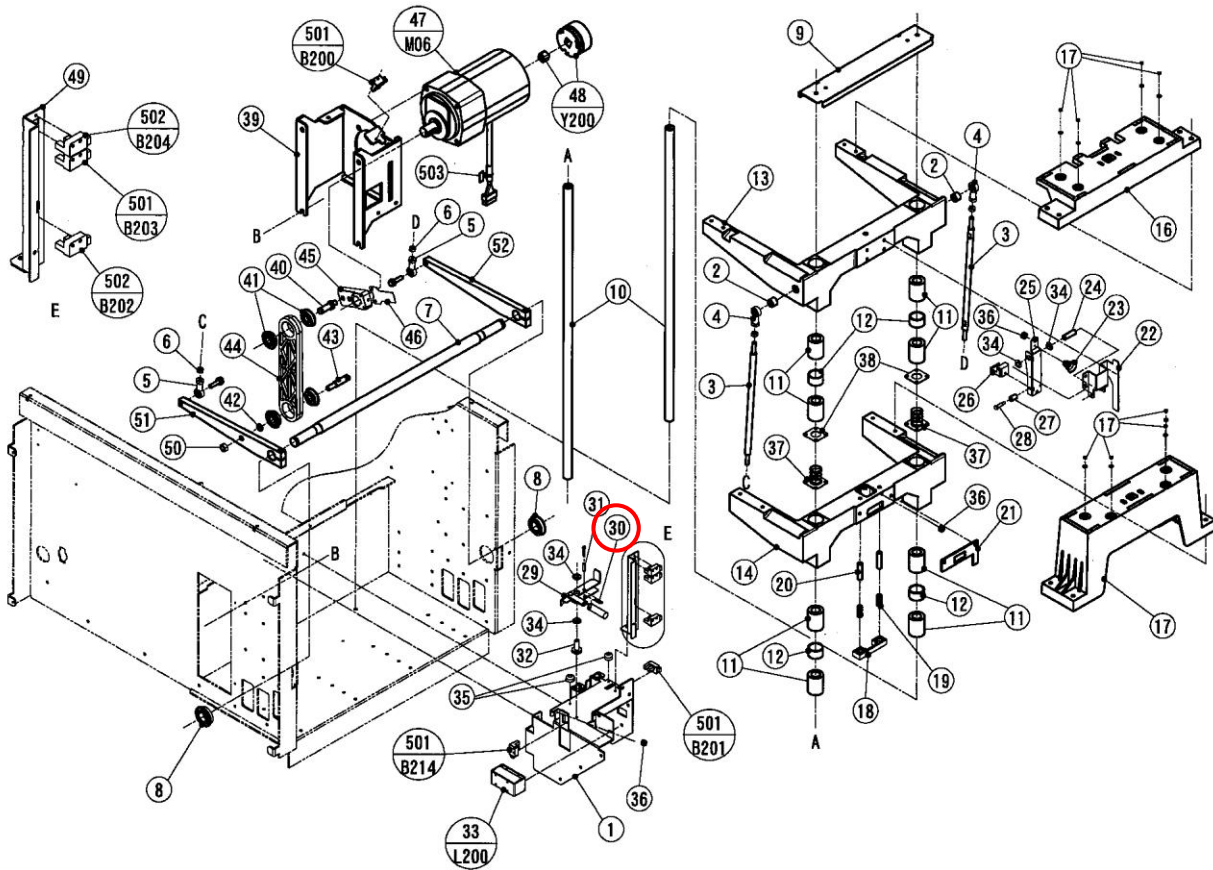

Exploded view



Apply the grease equivalent of "Shell Alvania Grease S" by Showa Shell Sekiyu to the springs of the lift drive unit shown below when replacing them.

- SPRING: COIL: COMPRESSIVE x1
(No.23 on the exploded view shown below)
- SPRING AS: COIL: COMPRESSIVE x2
(No.37 on the exploded view shown below)

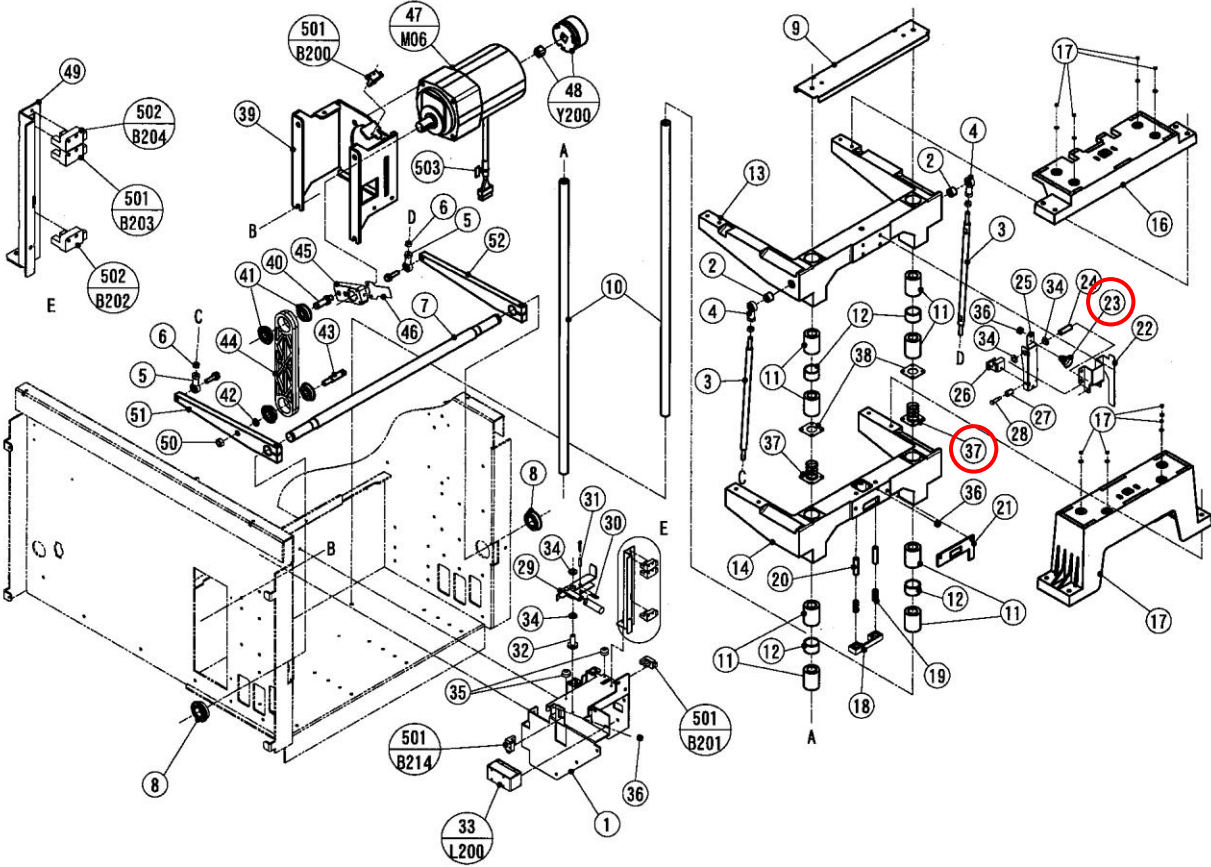

Exploded view



2.2.8 Wrapping Unit

2.2.8.1 Adjusting the belt tension

Check the belt tensions in the middle positions of the straight lines as indicated in the following figures.

Side wrapping unit (rear view)

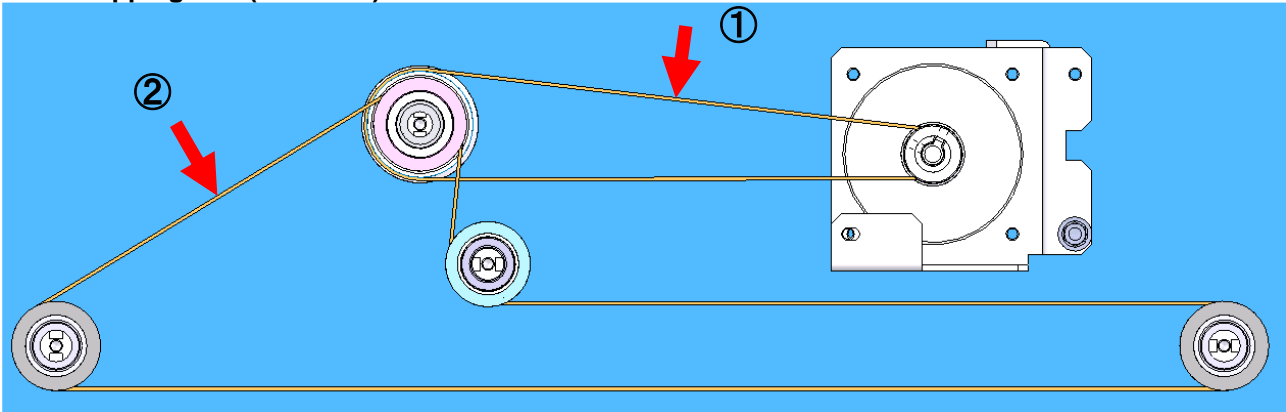

- 1) Timing belt 'HPS5M' 100HPS5M600
When the belt deflection is at 3.9 mm, pressing force is 448 to 722 [gf].
- 2) Timing belt 'S5M' 100S5M1350
When the belt deflection is at 3.2 mm, pressing force is 444 to 718 [gf].

Rear wrapping unit (side view)

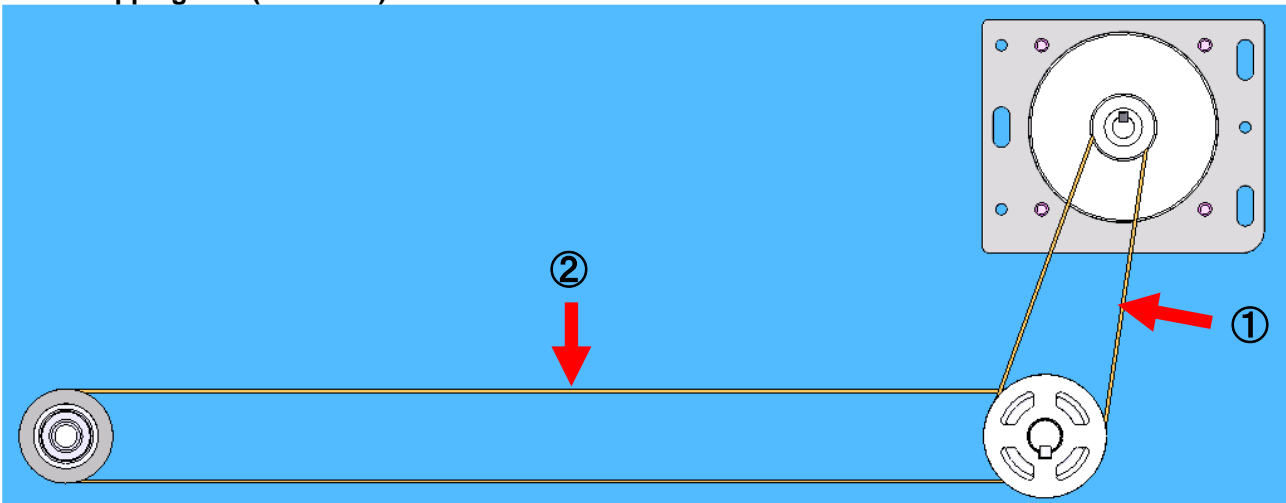

- 1) Timing belt 'HPS5M' 100HPS5M400
When the belt deflection is at 2.3 mm, pressing force is 439 to 713 [gf].
- 2) Timing belt 'S5M' 100S5M1000
When the belt deflection is at 7.0 mm, pressing force is 454 to 728 [gf].

Discharge pusher unit (side view)

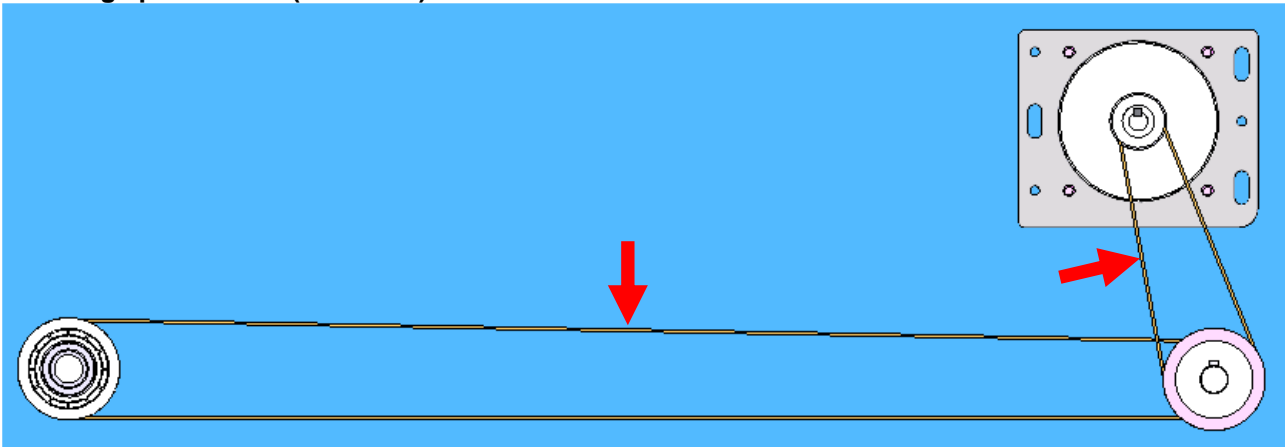

- 1) Timing belt 'HPS5M' 100HPS5M400
When the belt deflection is at 2.3 mm, pressing force is 439 to 713 [gf].
- 2) Timing belt 'S5M' 100S5M1350
When the belt deflection is at 9.7 mm, pressing force is 456 to 730 [gf].

2.2.8.2 Wrapping station (dimension)

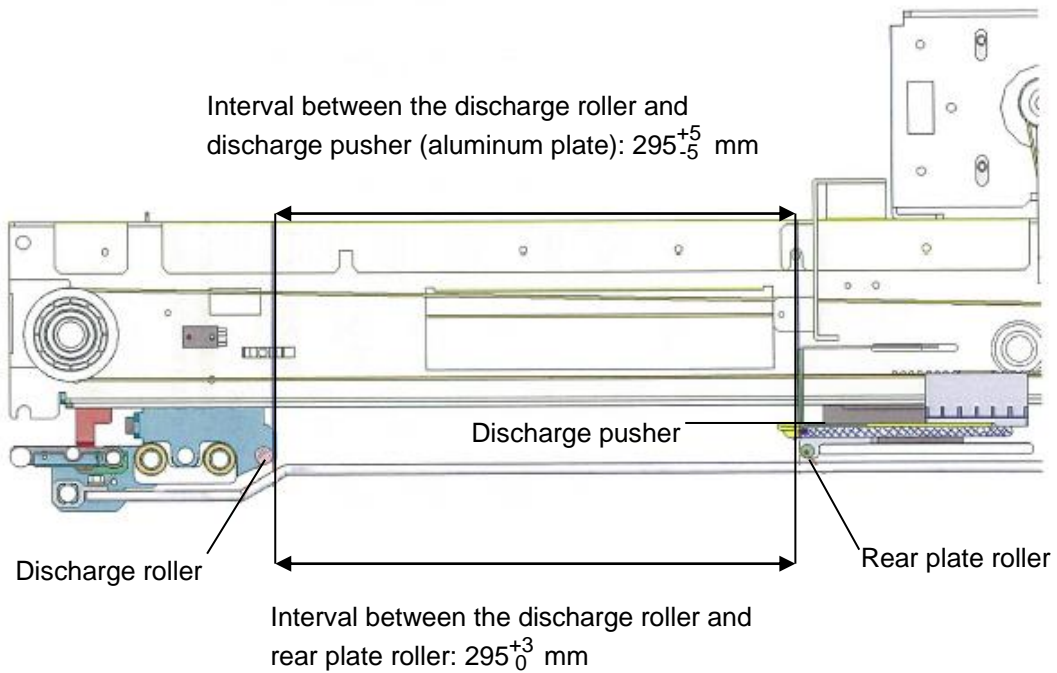
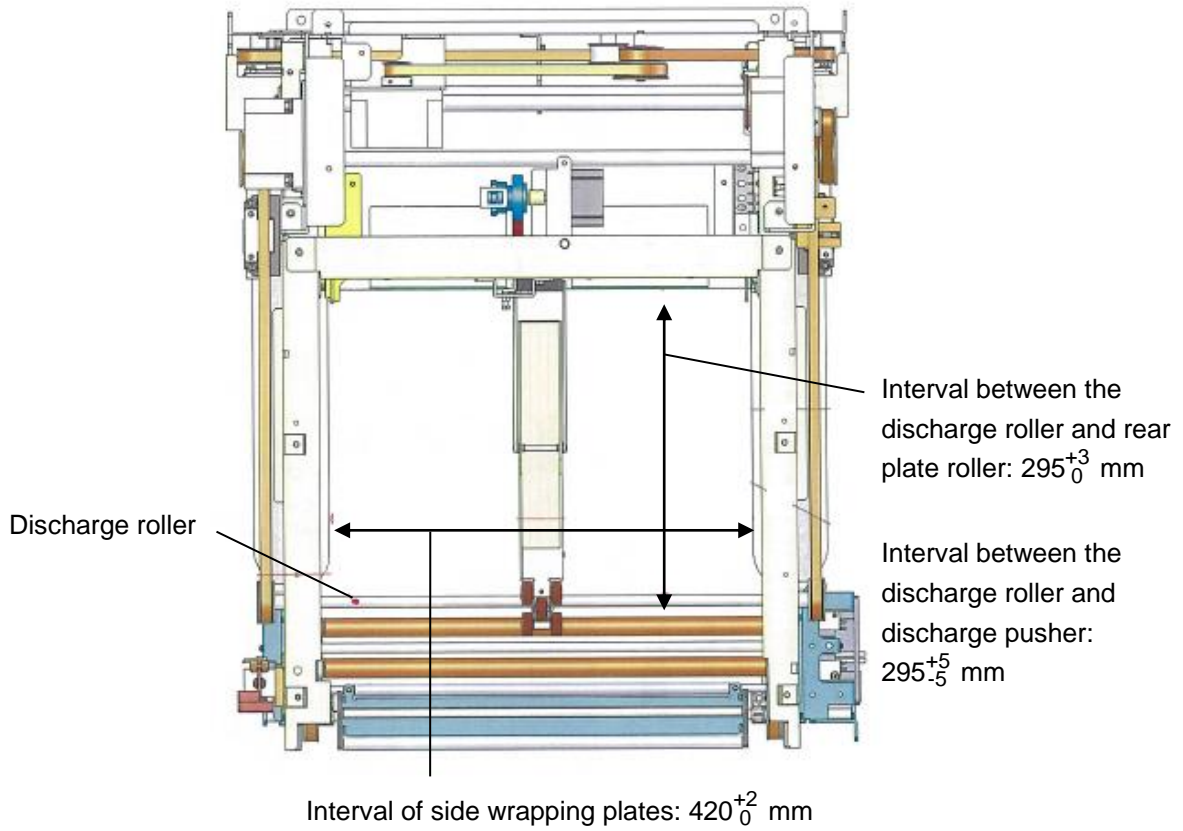

2.2.8.3 Interval between the side wrapping plates

Adjust the position of the sensor bracket to be set at the specified interval between the wrapping plates.



Sensor bracket

Bolt for adjusting the interval
between the wrapping plates

2.2.8.4 Interval between the discharge roller and the rear plate roller

Adjust the position of the sensor bracket to be set at the specified interval between the discharge roller and the rear plate roller.

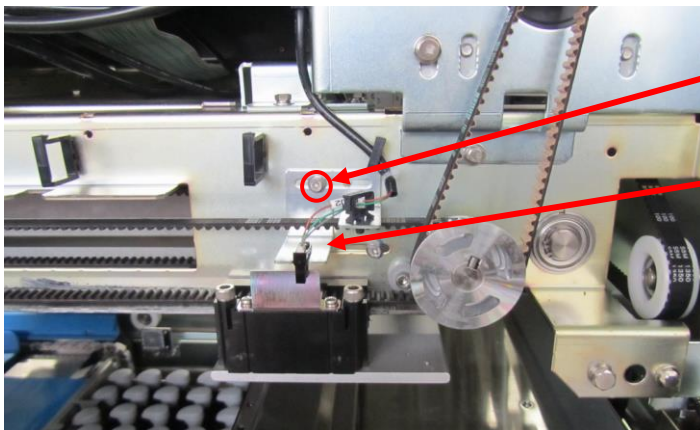

Bolt for adjusting the position of
the rear plate roller

Sensor bracket

2.2.8.5 Interval between the discharge roller and discharge pusher

Adjust the position of the sensor bracket to be set at the specified interval between the discharge roller and discharge pusher.

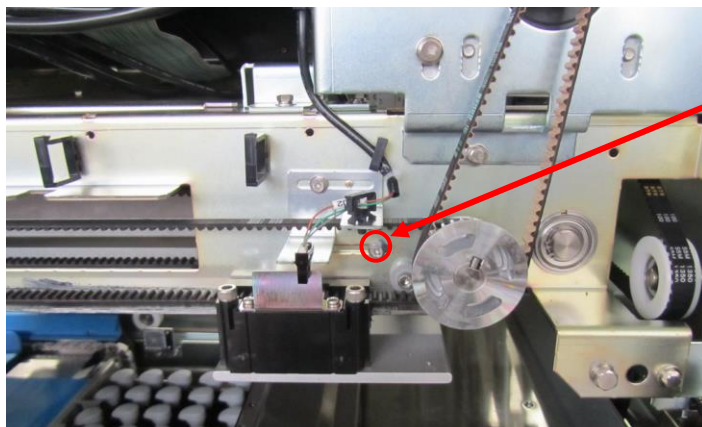

Bolt for adjusting the position of
the discharge pusher

2.2.8.6 Interval between wrapping plates

Place a 2.5 mm length board between the side wrapping plate and rear plate roller. Adjust the rear plate roller as not to come into contact with the 2.5 mm length board when rotating the roller by hand.

In addition, make sure that a 3 mm length board cannot be entered.

If the interval of wrapping plates becomes narrower than 2 mm, the side wrapping plates will be worn down and results in gloss to appear on the plates.

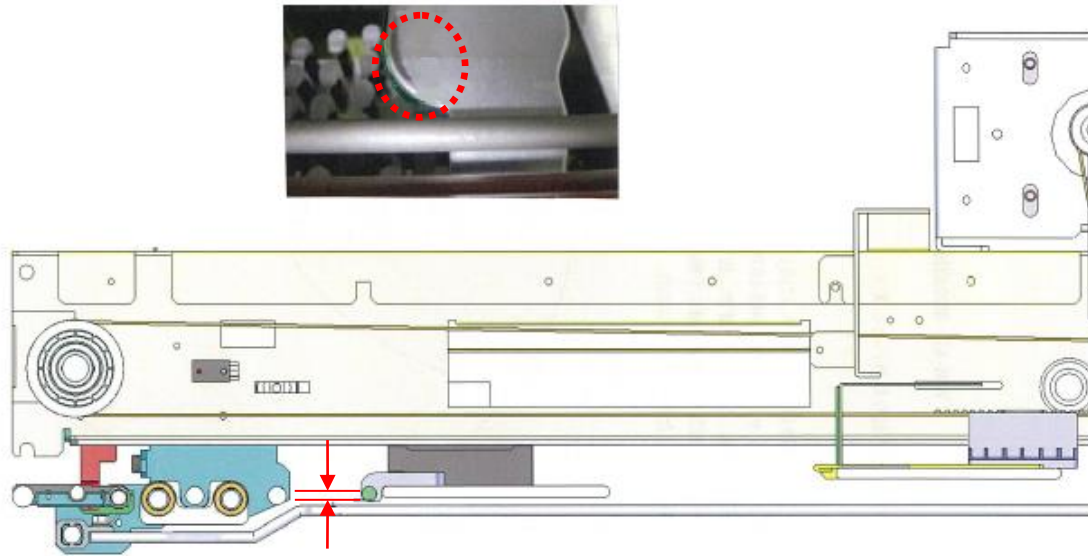

Interval between the side wrapping plate and rear plate roller
Adjustment range: $2.5_{0}^{+0.5}$ mm

2.2.8.7 Adjusting the positional relationship of the right and left wrapping plates (Reference)

The positional relationship of the right and left wrapping plates are affected by the stretch and variation of the timing belt. This section describes how to adjust the positional relationship when the right and left wrapping plates are asymmetrical.

As the minimum pitch of the mounting adjustment to the timing belt is 5 mm, adjustment should be performed at the place circled in the red circle as shown in the figure below when the pitch of less than 5 mm is required.

Note: After performing adjustment at this position, readjust the stretch of the timing belt for the right and left wrapping plates, and the opening between the right and left wrapping plates.

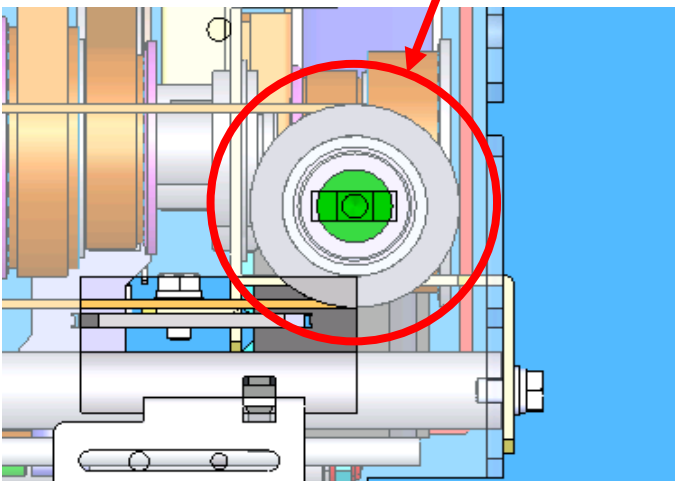
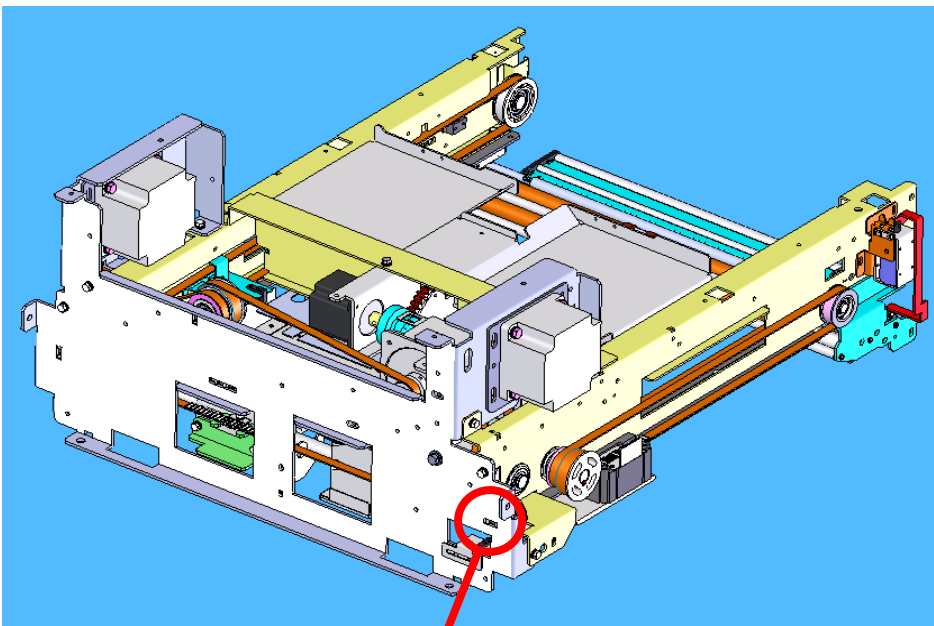

2.2.8.8 About the discharge pusher plate mounting position (reference figure)

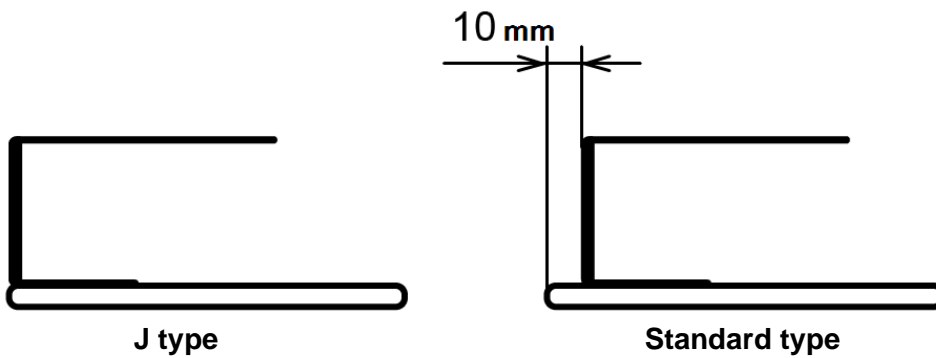
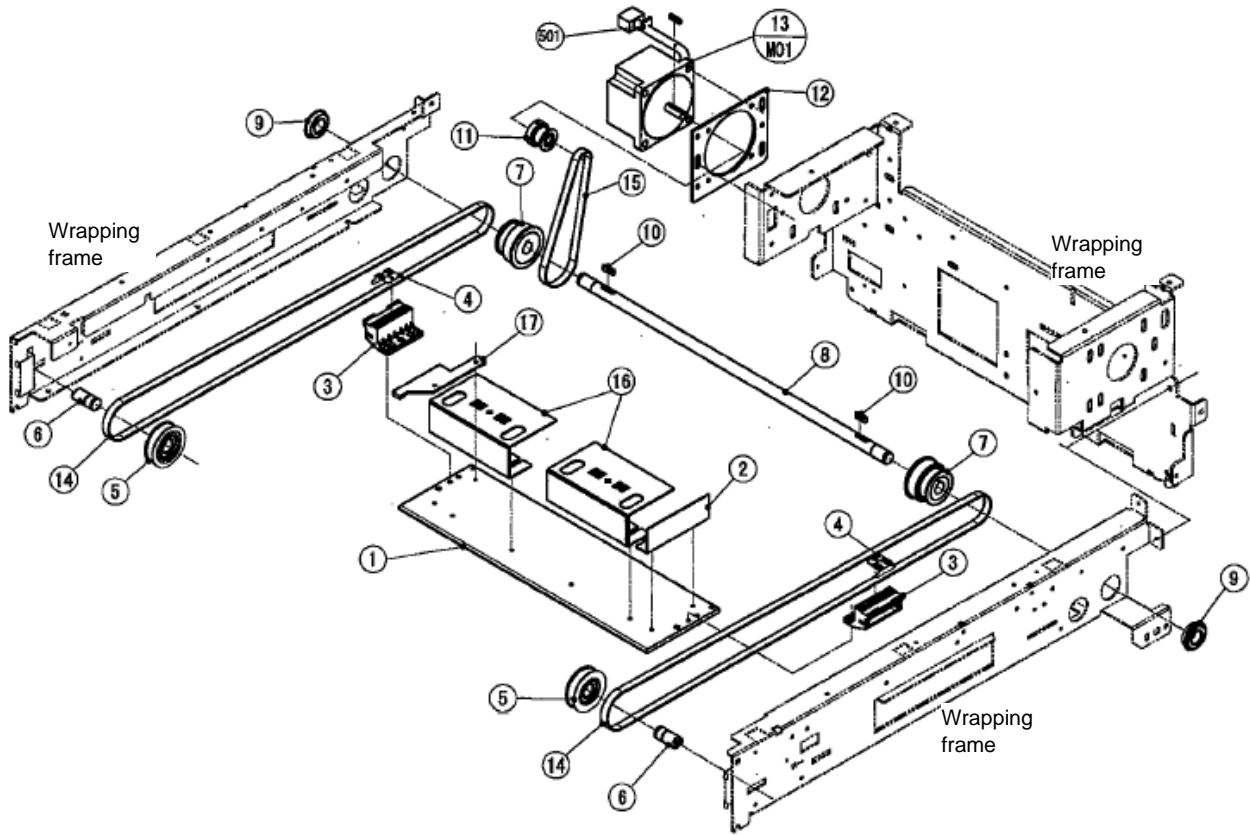

2.2.8.9 Setting Required for Activating Infeed Bar Overturning Suppressing Mechanism

Infeed Bar Overturning Suppressing Mechanism

By catching the rear edge of a tray by the support located at the top of the infeed bar when the tray rolls over and falls in the forward direction, this mechanism prevents the tray from rolling over any more.

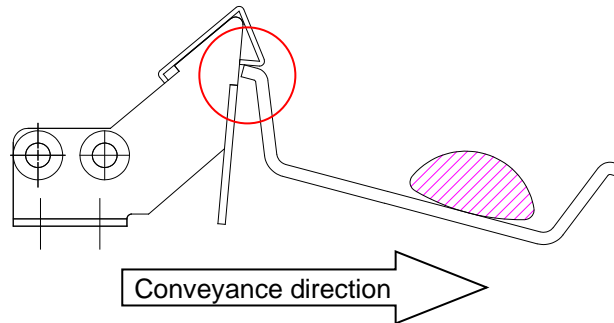

Setting Required for Effectively Activating an Overturning Suppressing Mechanism

Perform the following setting when needed in order to correctly supply and transport a commodity or a tray with the weight balance that may activate an overturning suppressing mechanism.

Set the feed position to "back" on the tray program screen.

● Reason

If the overturning suppressing mechanism is activated and a tray is supplied and transported in an inclined state, the inclined state may be kept when the infeed bar performs the back-feeding after the tray is transported to the feed position. In this case, the tray moves back with the back-feeding of the infeed bar, which may cause the tray coming in contact with the infeed bar or the discharge roller when the lift is elevated.

● Trays of which feed position should be set to "back"

- Tray to which the occurrence of overturn is anticipated during conveyance (e.g. lengthy tray for sauries, low-stack tray)
- Commodity with a high center of gravity
- Commodity with the gravity to the front from the center of the tray

● State where the feed position should be set to "Innermost"



- Lengthy tray
- The gravity balance is located forward.



- Low-stack tray
- The gravity balance is located forward.



- Lengthy tray
- Gravity balance is high and forward.



- The gravity balance is located forward.

- Other use conditions in which the feed position is recommended to be set to "Innermost"

- Cases where the tray height is 50 mm or more

Note: If the tray height is 50 mm or more, the tray end cannot be conveyed to an appropriate position because the infeed bar cannot push the upper end of the tray.

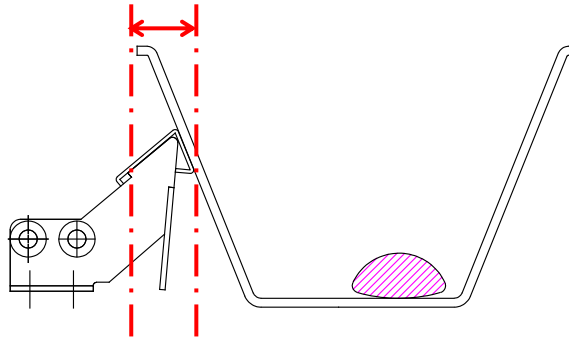

- Cases where the ultra-stretch film is used and the stretch amount has been set large. (150% or more as a guide: Amount of the feeder movement for wrapping is more than 50% of film width.)

Note: By separating the distance between the front clamp and the tray, the film tension on the front feeder side will be eased, which prevents the film from being easily torn.

- Possible problems caused by the activation of the overturning suppressing mechanism and the coping method.

As possible problems caused by the activation of the overturning suppressing mechanism, damages of a tray such as cracking and folding may be caused after supply and conveyance of the tray. If the tray is supplied and transported in an inclined state while the overturning suppressing mechanism is being activated, the tray gets into a state where the conveyance is braked due to the force of friction between the head surfaces and the tray when the tray runs on the lift heads, and pushing in the tray with the infeed bar in this state will cause damages to the tray.

Countermeasures to a case that such a phenomenon occurs are described below.

- Confirm that the height of lift heads is lower than the connection plate.
- Replace the heads at predetermined position with POM heads to reduce the friction between the lift heads and the tray. Instead of the POM heads, the standard lift heads with their surfaces filed and roughened with sandpaper can be used as an emergency measure.

- Easily damageable trays

Trays of which surface is laminated as typified by eco-trays manufactured by FP Corporation.

2.2.8.10 Adjusting the Projection Amount of the Pin Spike



1. Remove the holding bar.

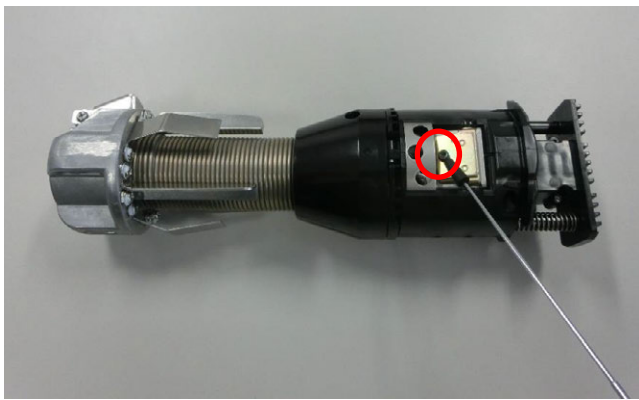

2. Turn the hexagon socket adjustment screw to adjust the projection amount of the "pin spike".

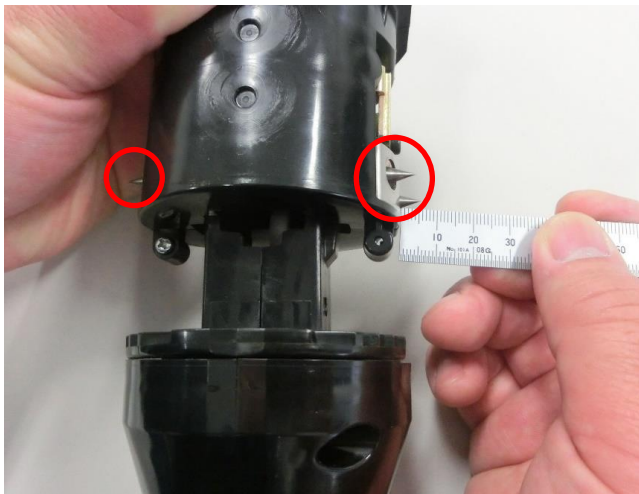

3. Adjust the projection amount of the pin spike at the center among three spikes to be 5 mm.

Note:

In the event of the idle or uneven rotation of the film roll, adjust the projection amount of the pin spike to optimize the film roll rotation. The projection amount of the pin spike has been adjusted based on ISHIDA's original film roll.

4. Upon completion of the adjustment, apply thread locker to the adjustment screw.

2.2.9 Heater Unit

2.2.9.1 Adjusting the solenoid for heater guard

Perform adjustment of the solenoid for heater guard according to the following method.

- ① Manually pull the discharge pusher until it becomes the condition as shown in Figure 1.
- ② With the condition shown in Figure 1, perform solenoid adjustment satisfying the following conditions.
 - Turn ON/OFF the emergency stop switch, and the heater guard operates with the condition as shown in Figure 1.
 - With the emergency stop switch OFF, the heater guard must not be floated with the condition shown in Figure 1.
(Refer to Picture 1.)

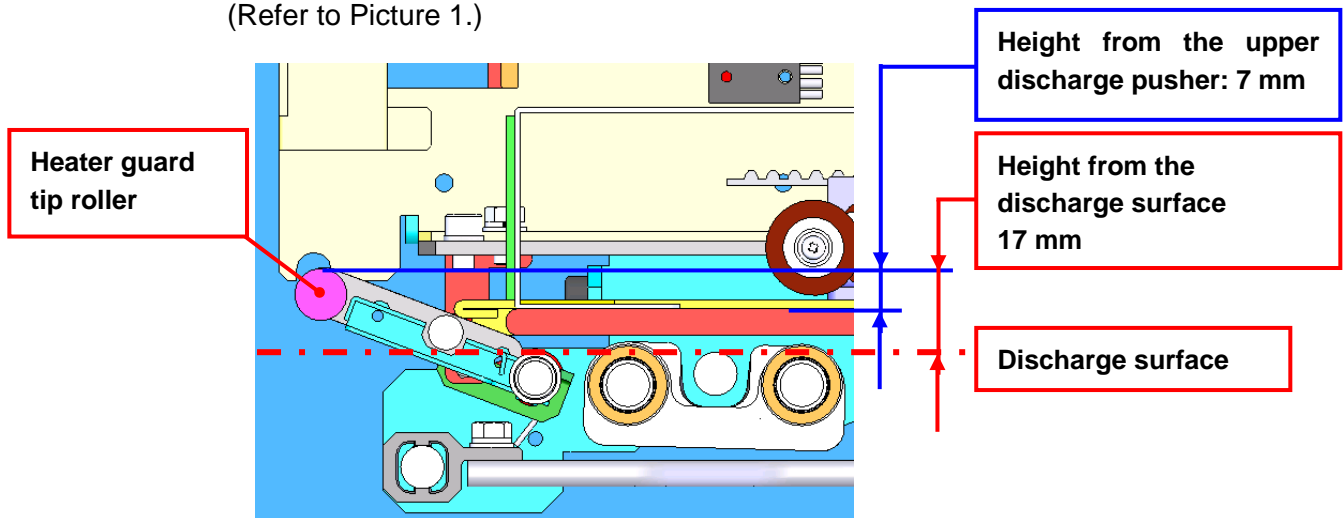

Figure 1



Picture 1: Heater guard

2.2.10 Cutter Unit

2.2.10.1 Gap between cutter base and cutter

Adjust the gap between the cutter base and rubber part to be 2 mm or more as shown in the figure below.
(Design value: 3 mm)

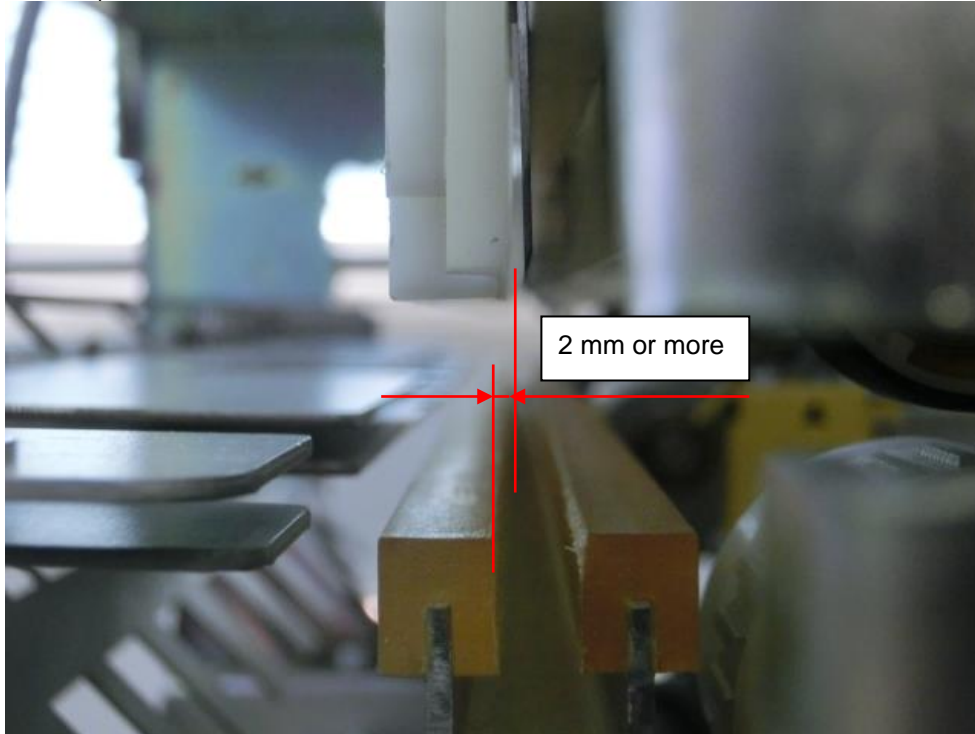

Gap between the cutter base and cutter

2.2.10.2 Applying grease on the cutter block

Apply the grease equivalent of "Shell Alvania Grease S" by Showa Shell Sekiyu on the area shown on the figure below.

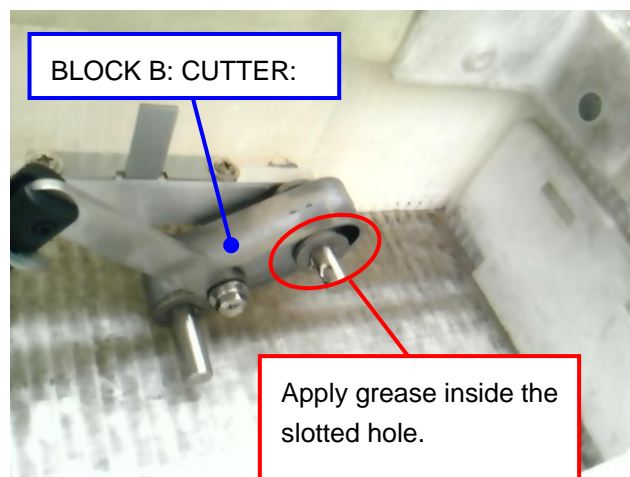

2.2.10.3 Applying grease on the cutter spring

Apply "Shell Alvania Grease S" by Showa Shell Sekiyu on the spring area of the cutter unit. (Refer to the figure below.)

<Spring at the front of the machine>

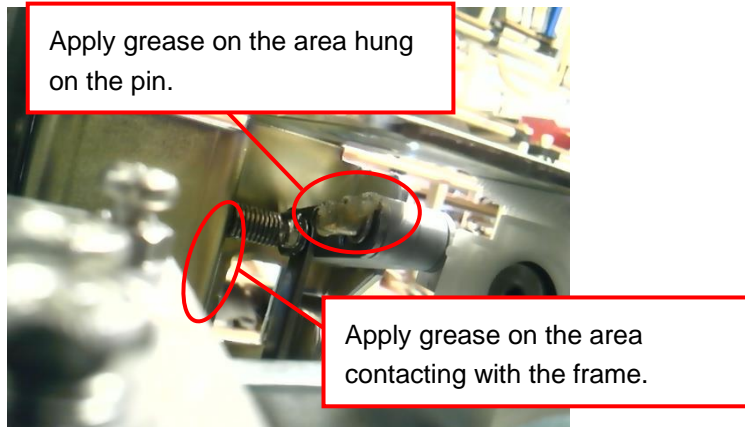

<Spring at the back of the machine >

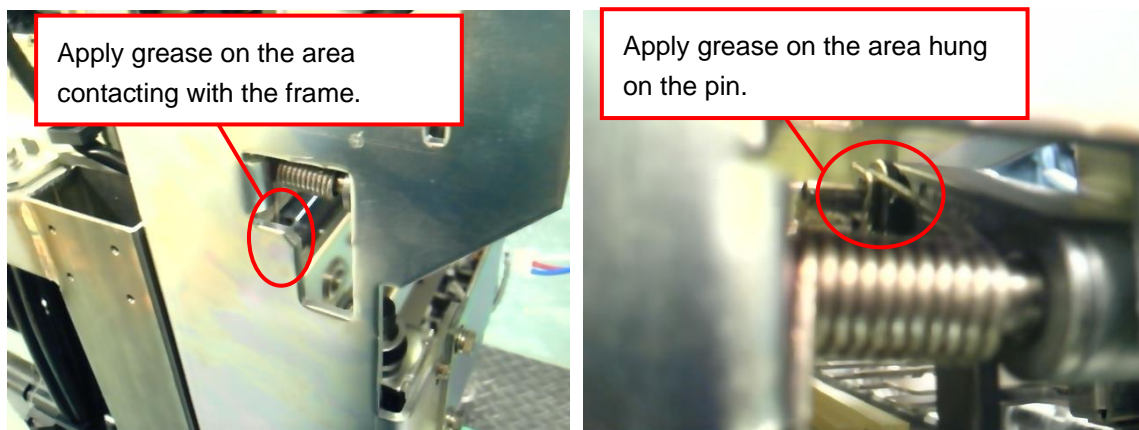

2.2.10.4 Adjusting the film cutter

Note: Compared to during a film feed, when cutting during film loading, the film tension is slack, and cutting is difficult and, further, wide films have great resistance to the cutting blade, so before shipping, checks are made to see that cutting during film loading is possible using a 500mm-wide Ishida Wrap Super I-FA film (Polyfilm).

During repairs, use a wider film to check that cutting is possible during film loading.

1. Loosen the screws that secure the cutter solenoid front and back, and lower the solenoid to its lowest position. (I.e., lower the cutter blade to its lowest position.)
2. Push the center of the aluminum block using a screwdriver, and lower the cutter blade to its lowest position.

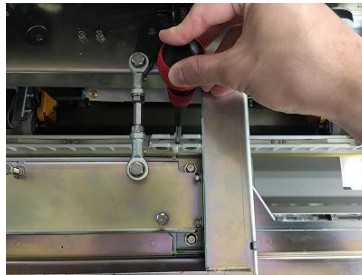
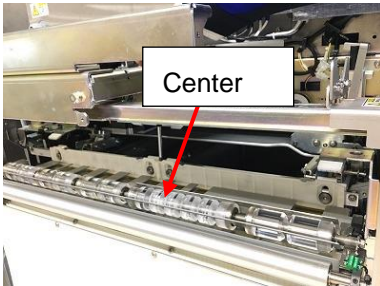

3. Gently push down the iron core under the conditions in step 2., and adhere and secure the iron core and the solenoid in this position.

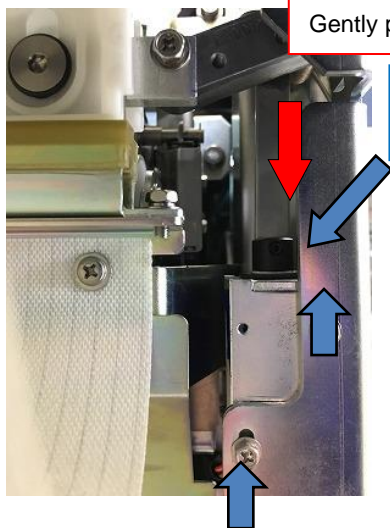

Gently push up the iron core, and lower and align the link gutter only

Adhere and secure the iron core and the solenoid
Adhere to the extent that the rubber washer does not rotate

If the iron core is pulled down too forcefully, there is a possibility that the opposite side will lift up, so be careful. Adjust while maintaining the conditions described in 1.



Note:

During adjustments, the cutter unit may move, so be careful. Make sure to maintain the conditions described in step 2. during adjustment.

4. Adjust the back solenoid in the same way.

2.2.11 Roll Hold unit

2.2.11.1 Adjusting the belt tension of roll hold unit

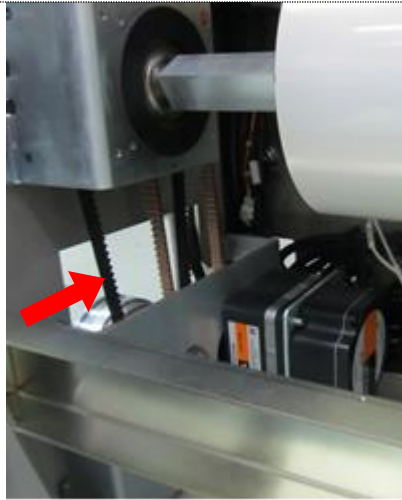
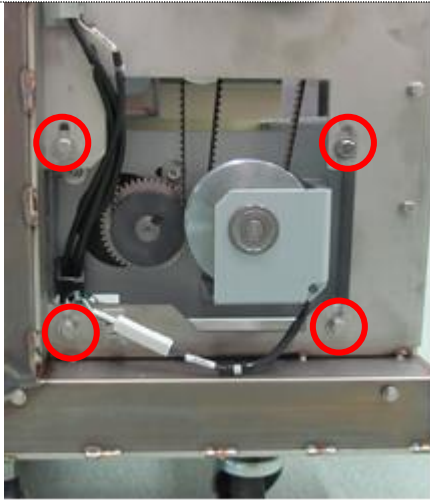

Adjust the belt tension of the lower roll.
 Loosen the 4 bolts indicated in the circle in the picture, adjust the position in the vertical direction to set the belt deflection and pressing force at the specified value.
 Belt deflection is at 3.4 mm
 Pressing force is 438 to 712 gf

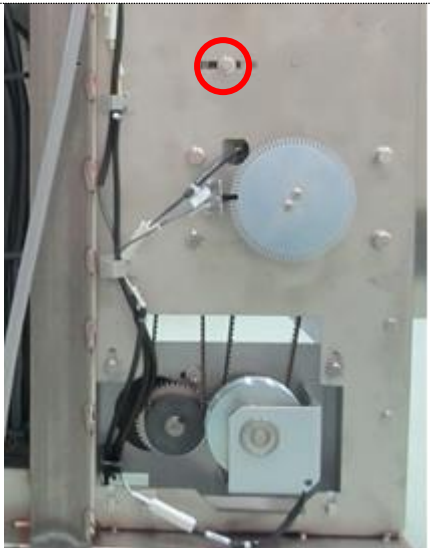

Adjust the belt tension of the upper roll.
 Loosen the bolts indicated in the circle in the picture, adjust the idler pulley in the right-left direction to set the belt deflection and pressing force at the specified value.
 Belt deflection is at 7.3 mm
 Pressing force is 450 to 724 gf

2.2.11.2 Change of BEARING UNIT:FLANGE: for Film Holding Rod

The BEARING UNIT:FLANGE: that fixes the last part of the film holding rod has been changed to one that can more easily rotate the spherical outer ring. It is now easier to align the two bearings that support the shaft of the holding rod, and ensure smooth rotation during assembly.

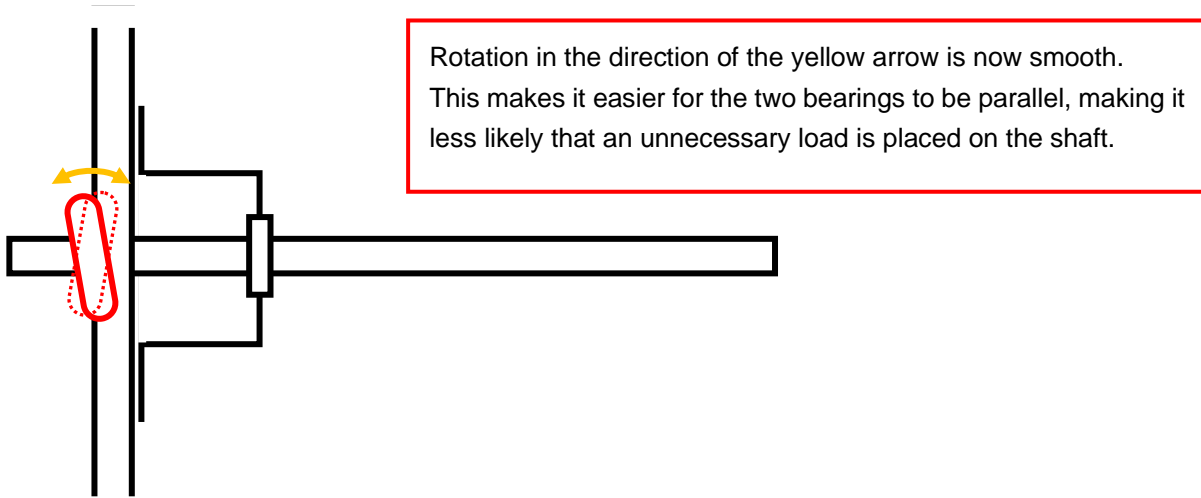

Old part number	Name		New part number	Name
000-030-6417-**	BEARING UNIT:FLANGE:	→	000-032-6744-**	BEARING UNIT:FLANGE:
			100-021-1579-**	COLLAR A::



REFERENCE

Old parts can be used and supplied, but new parts are recommended to improve functionality.

The new BEARING UNIT:FLANGE: can be used on the film holding rod before the change by adding a collar.

2.2.11.3 How to Replace the Bearing Unit

<When installing a new type bearing on an old type shaft>

1. Loosen the drive belt tension.
2. Remove the parts ① to ③ shown in the figure below. Discard ② and ③.
3. Install 100-021-1579-** COLLAR A:: and 000-032-6744-** BEARING UNIT:FLANGE: to the holding rod shaft.

Temporarily tighten the BEARING UNIT:FLANGE: bolts.

4. Adjust the holding rod brake gap and fully tighten the BEARING UNIT:FLANGE: bolts.

(The gap gauge tool of 0.2 mm thickness must pass the gap without any resistance. The gap gauge tool of 0.3 mm thickness must not pass the gap, or there must be resistance when inserted.)

5. If you cannot set the brake gap correctly, loosen the fixing bolts ④, fix the bracket to the top, and adjust the brake gap again.
6. Fully tighten the BEARING UNIT:FLANGE: screws and attach ①. Adjust the drive belt tension.

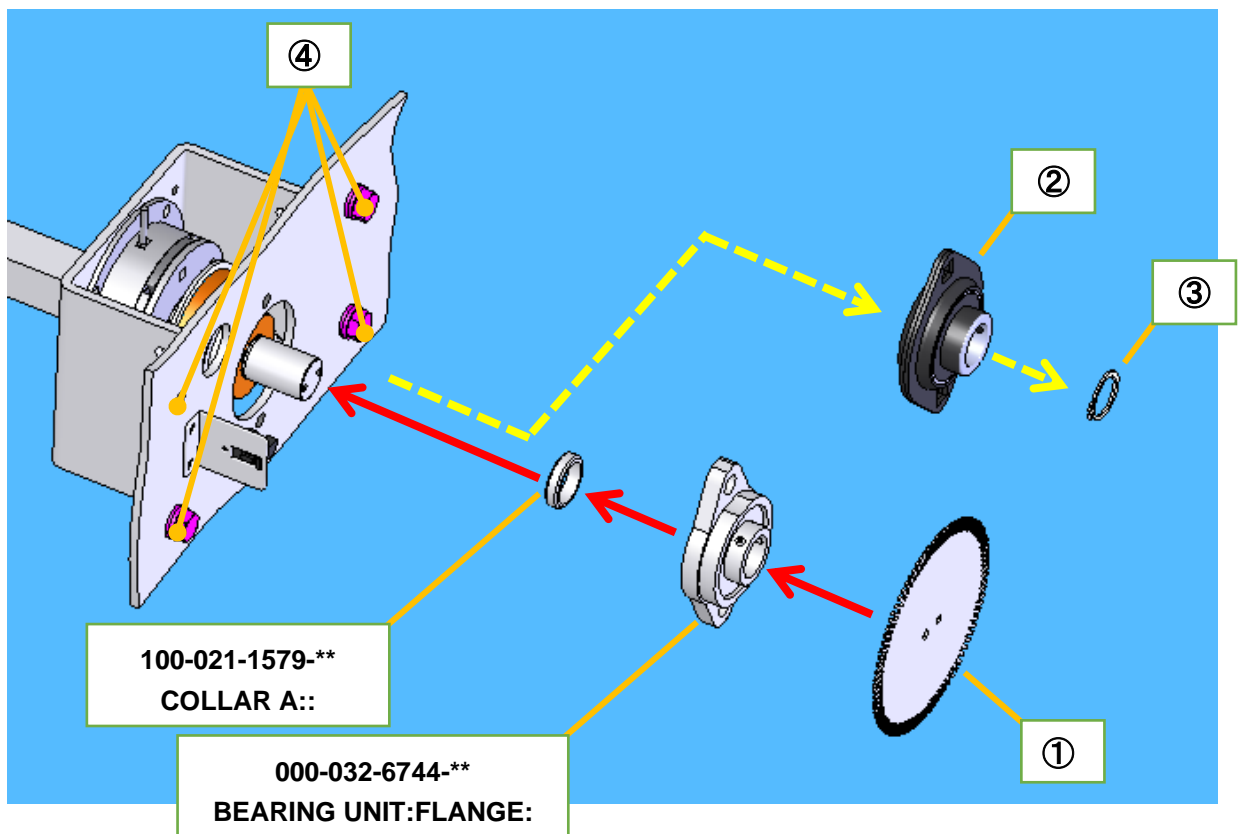

2.2.11.4 Adjusting the brake gap

Perform gap adjustment to satisfy the following condition for the gap between the brake and armature. Refer to Pic.1 for the gap to be checked.

- ① 0.2 mm The gap gauge tool of 0.2 mm thickness must pass the gap without any resistance.
- ② 0.3 mm The gap gauge tool of 0.3 mm thickness must not pass the gap, or there must be resistance when inserted.

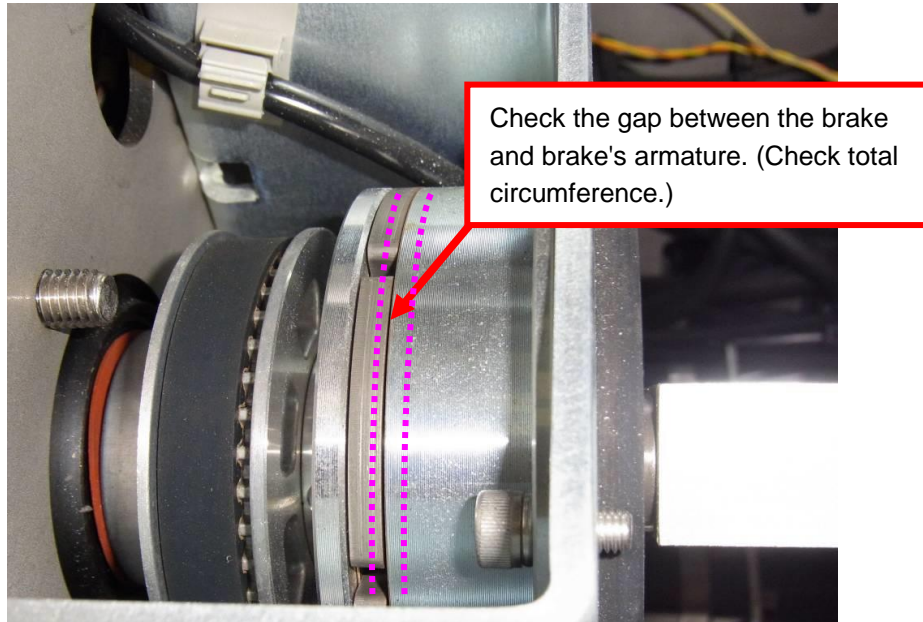

Picture 1: Check the brake gap

2.3 Replacement the Mechanical Units

2.3.1 Printer Unit

2.3.1.1 Replacing the thermal head

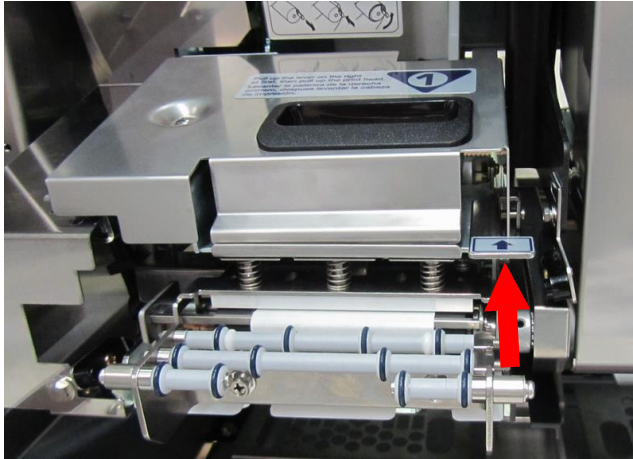

1) Press the lever, then, lift up the printer head.

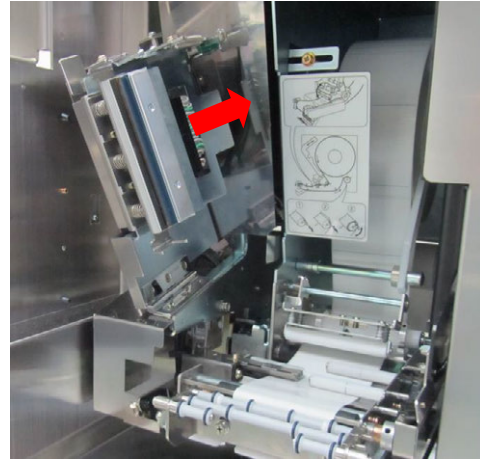

2) Remove the connector toward the arrow direction.

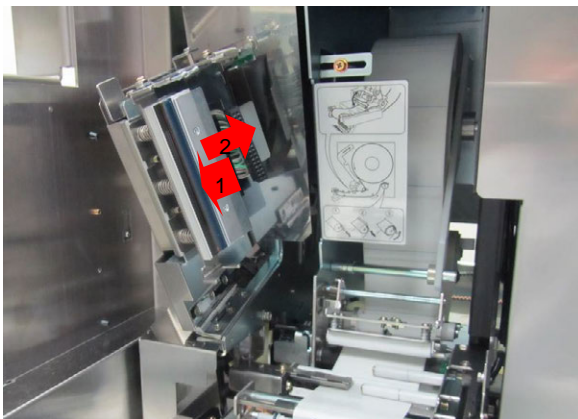

3) Remove the thermal head bracket by moving backward.



4) When the bracket is removed.

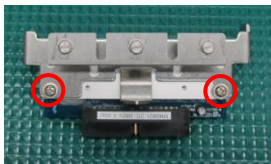

5) Remove thermal head by loosening the two screws indicated in the circles in the picture. Replace it with a new thermal head. To attach the thermal head, perform the procedure in the reverse order of detaching.

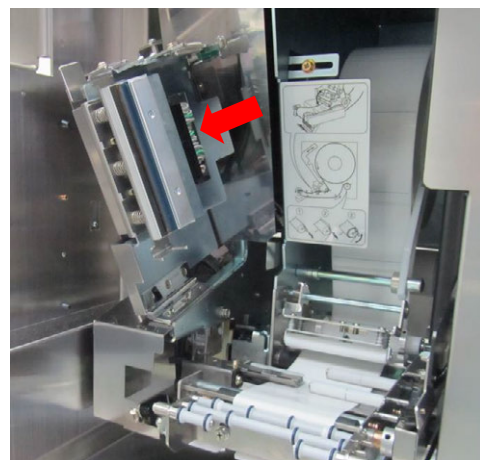

6) Connect a connector.

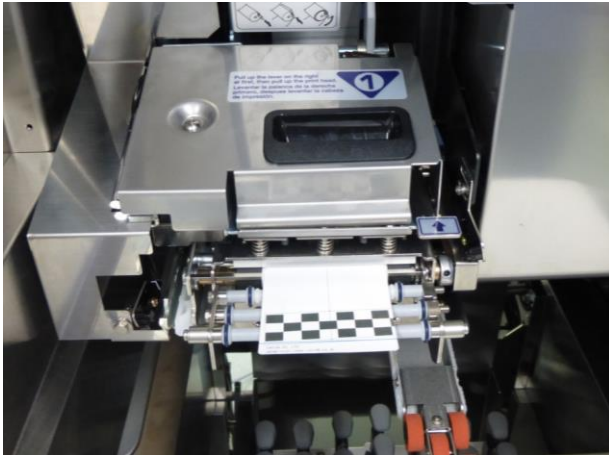

7) Set the thermal head in its original position. From the [PRINTER (HEAD)] screen of ADJUST mode, set a resistance value. Perform a test printing to check for successful printing.

For description on Adjust Mode, refer to *Chapter 5 Adjust Mode*.

2.3.1.2 Replacing the peel sensor

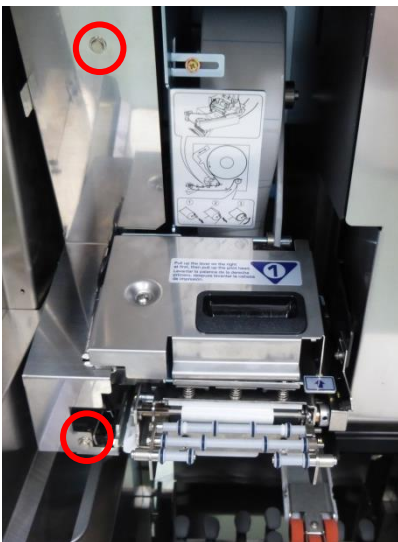

1) Detach the cover by removing the two screws.

The light emitting side

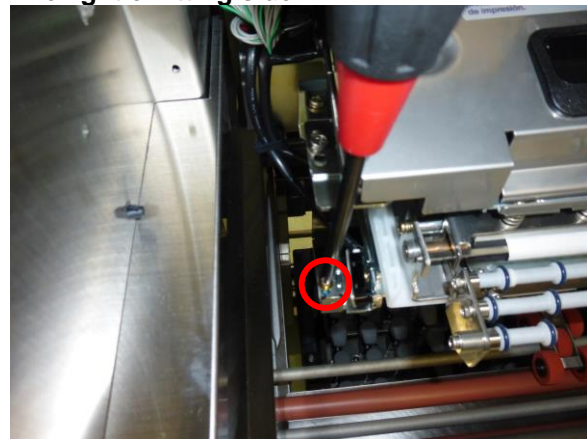

2) Remove the sensor bracket and sensor connectors. Remove the sensor from the bracket to replace it.

The light receiving side



3) Lift up the printer head, then remove the sensor connectors. Remove the sensor from the bracket to replace it.

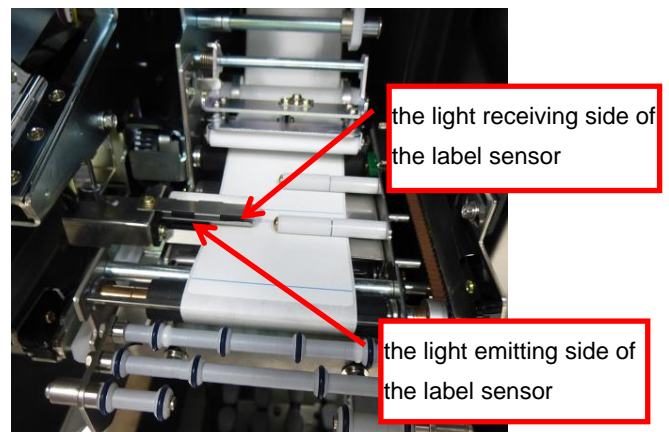

4) Position of the label sensor

2.3.1.3 Replacing the label standby roller unit

O-rings are provided in the center of the standby roller to prevent a suction error of the labels that are warped upward on both ends and warped downward in the center.

This machine employs an adjustment function in the width direction so that an adequate space (space 0.5 to 1.1 mm) is given against a dimension error of collar. This reduces the front/ rear slack in the right-side shaft. At shipment, layout of O-ring is set for a 60 mm wide label. If the value is different, replace the collars and O-rings.

<How to install>

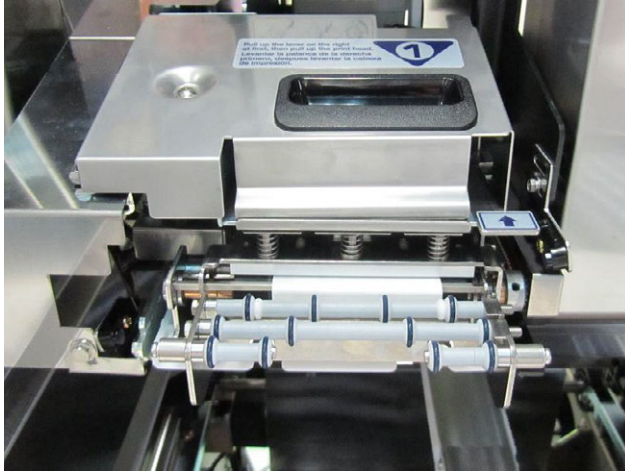

Three holes are provided in the bracket of the label standby roller unit.

Use the two holes located on both ends.

For No.1 and No.2 machines, the front/ rear positions of the label standby roller are located in backward side.



The number of standby rollers may increase depending on the label size.

2.3.1.4 Replacing the label standby roller

The estimated timing for replacing the label standby roller is 350,000 times of wrapping count or 13.8 km of travel distance, either of the shorter period. This period is shown when on condition that number of the times of wrapping and labeling are considered equal.

The replacement may be required earlier than the estimated replacement timing. If a suction error of the labels occurs, visually confirm the O-rings of the label standby roller. When significant fogging happens on the surface, which indicates the non-adhesiveness of the roller has been deteriorated, so replacement is recommended.

2.3.1.5 Replacing the label sensor and head-up sensor

The label sensor consists of the light emitting side, light receiving side, head-up sensor, and peel sensor (see Figure 1). These units are replaced all together.

Note:

After the replacement, the sensor level needs to be adjusted for the label sensor.

To adjust the label sensor level, set the label sensor level on the [PRINTER (LABEL FEED)] screen of ADJUST mode.

For description on adjust mode, refer to *Chapter 5 Adjust Mode*.

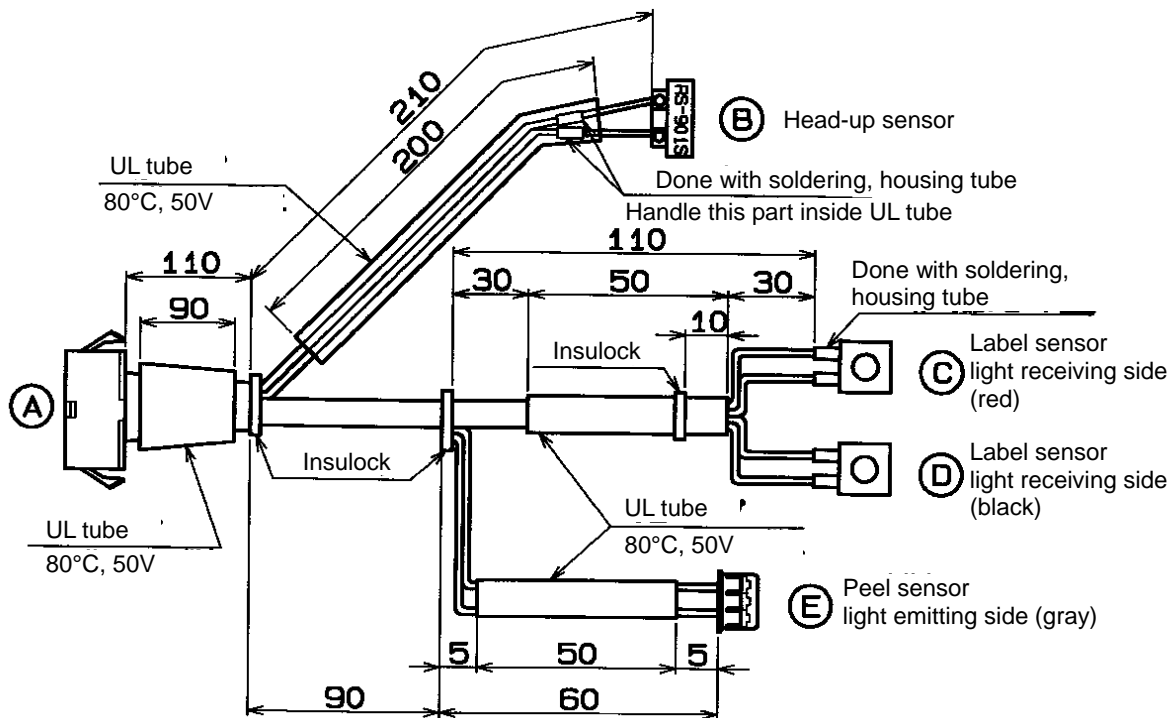
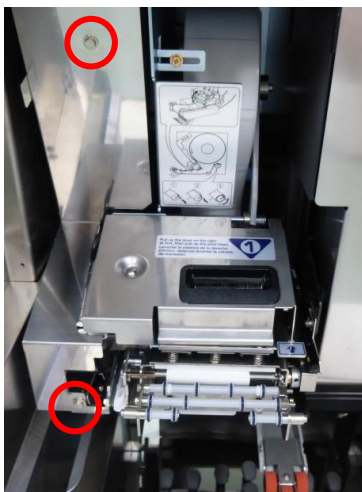
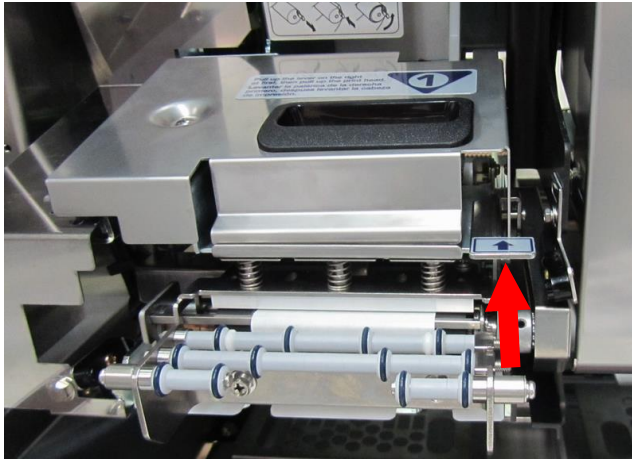

Figure 1



- 1) Detach the cover by removing the two screws.
- 2) Lift up the printer head, then remove the head-up sensor.

2.3.1.6 Replacing the print roller



1) Lift up the printer head.



2) Pull out the printer.

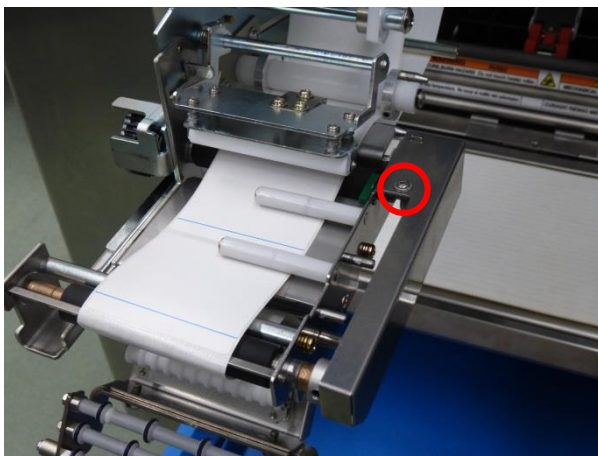

3) Remove the cover by loosening a screw indicated by the circle in the picture.

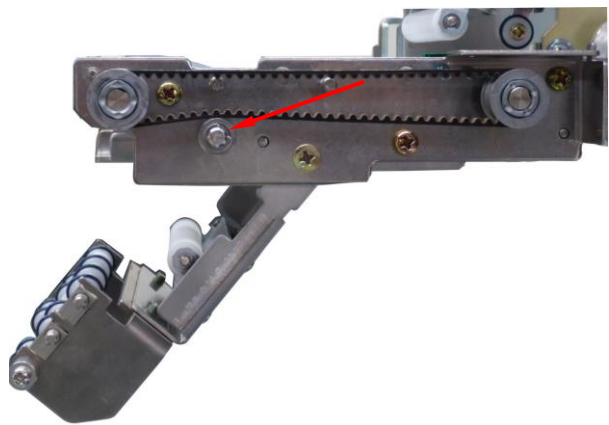

4) Loosen tension pulley.

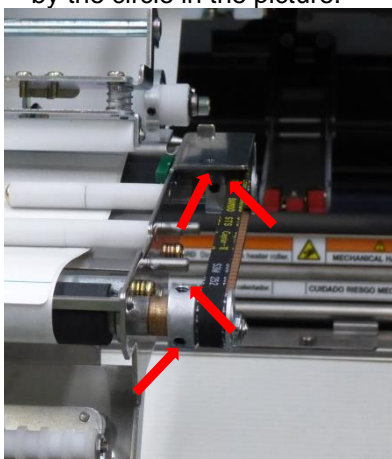

5) Remove the timing belt and pulley after loosening the four screws indicated by the arrows in the picture.

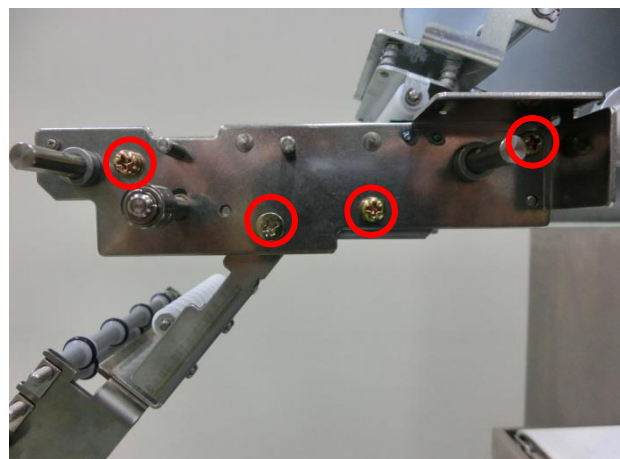

6) Remove the print roller by removing the frame after loosening the screws indicated by the circles in the picture.

2.3.2 Applicator Unit

2.3.2.1 Replacing the Suction Block

Estimated Timing

The estimated timing for replacing the suction block is 150,000 times of wrapping count (labeling count).

Note: This estimated timing has been derived from the results of use under the condition described below.

Temperature: 20 to 25°C

Humidity: 35 to 50%

Label: V8NS 60 mm x 37 mm

Film: UP film (Perform wrapping with the same stretch amount as that with ISHIDA Wrap Super)

Tray: 200 mm x 130 mm (Standard trays or equivalent)

Labeling position: Lower-right

Label applicator control: Labeling sensor reference

Commodity shape: The film is flat with few commodity filling.

- Conditions where the replacement frequency may increase because a packaging film is torn earlier than the estimated replacement timing.
 - When the film thickness becomes reduced by performing the ultra-stretch, or when using thin film other than recommended ones.
 - A highly filled commodity with the shape which makes it easy for the suction area to come in contact with wrapped film. (Even if a commodity is filled up high, a packaging film will not easily be torn when setting has been made so that labels are stuck at the top of the filling.)

Replacing the printer suction head



1. When the suction surface of the printer suction head is worn out, replace the suction head. This figure shows a new suction head.

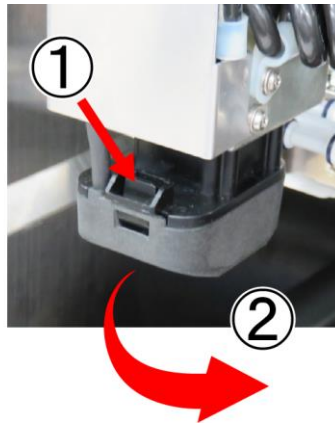
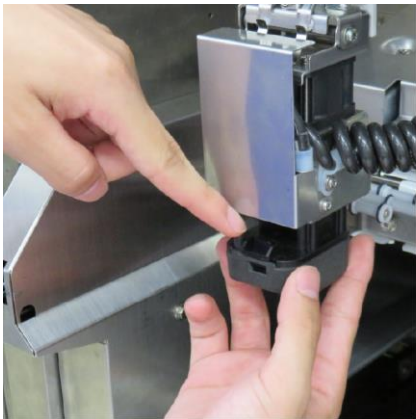

2. Remove the suction head by pressing the hook indicated by the arrow in picture and pulling down the suction head.

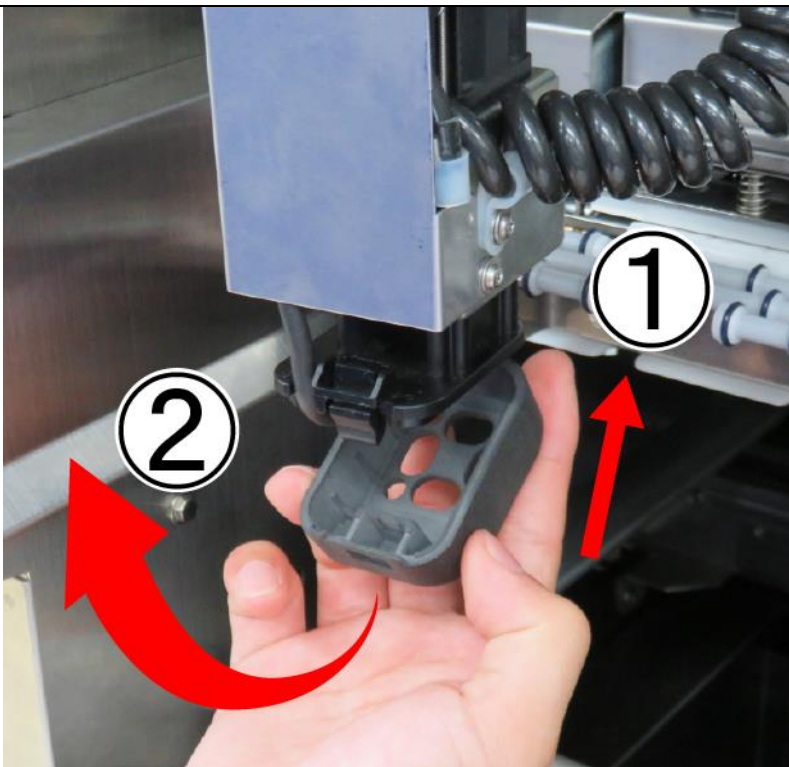

3. To attach, engage the backward hook, and press it upward until making a clicking sound.

2.3.2.2 Disassembling, Assembling, and Adjusting the suction unit



It might not operate normally if you do not use the parts following method of assembling the applicator unit. In addition, follow a method for assembling the number of washers.

Removing the applicator unit

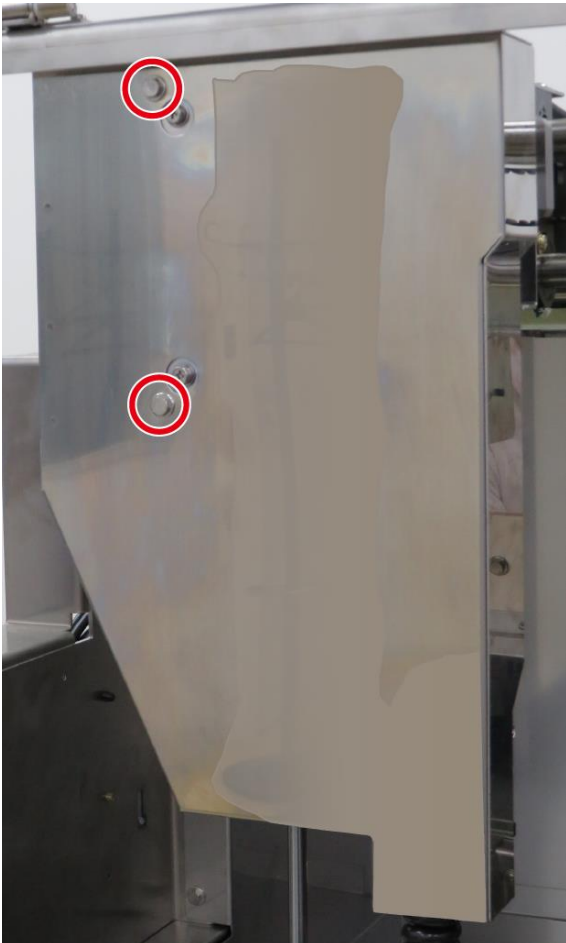

1. Remove two screws and a cover of the applicator unit.

2. Cut off three tying bands. Then extract a curled cord from upper of frame to open the cord holder.

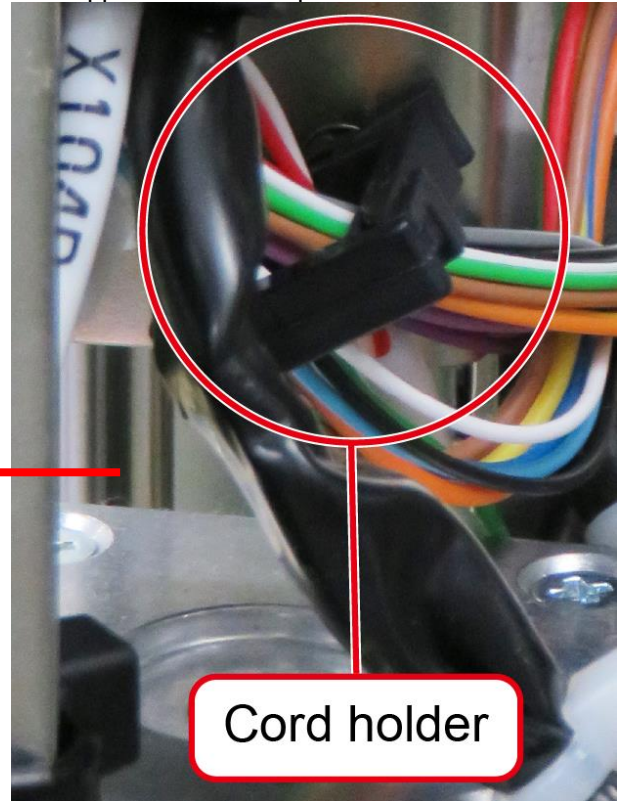
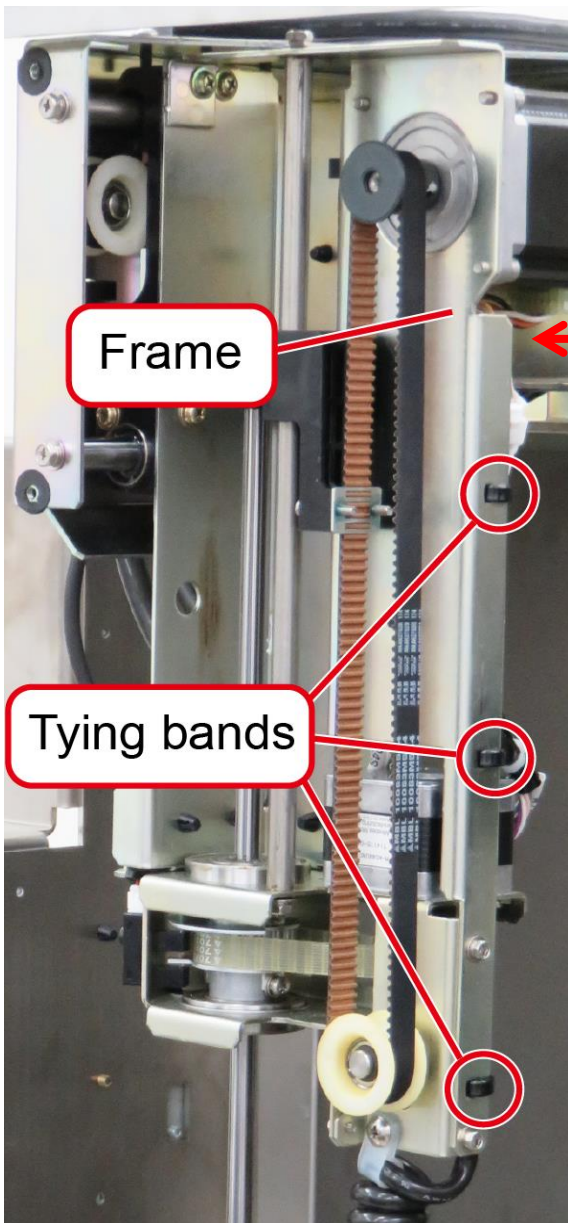

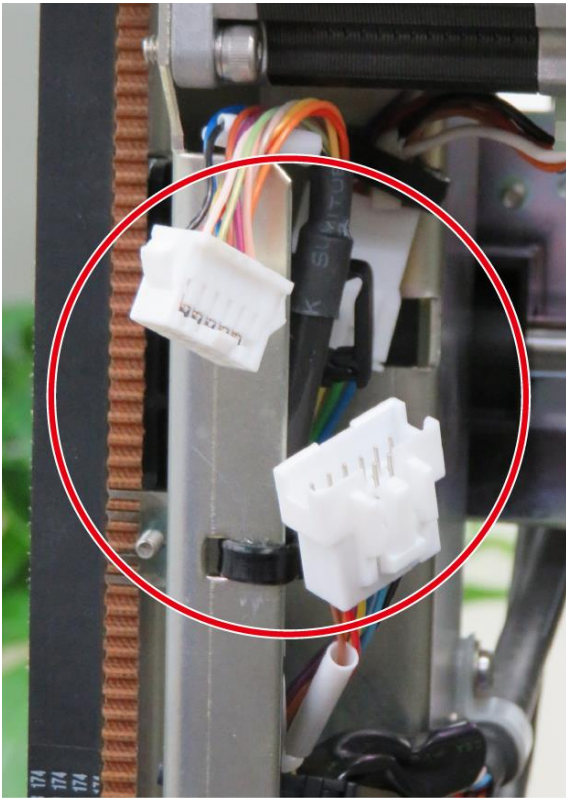

3. Unplug the connector, remove a cable clamp and the curled cord from the frame.



4. Remove a screw and the applicator unit.



5. Remove three screws and the applicator unit cover.

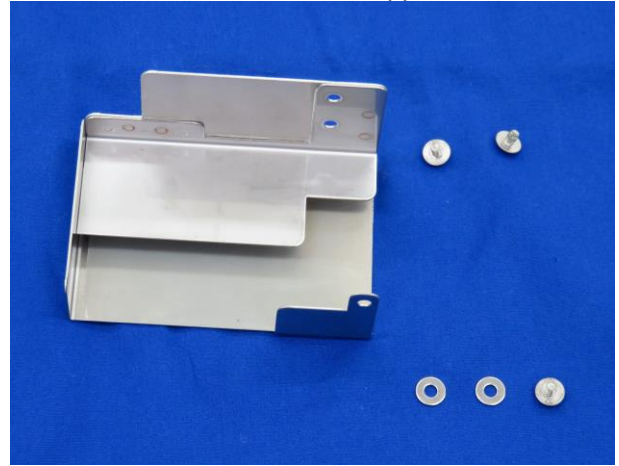
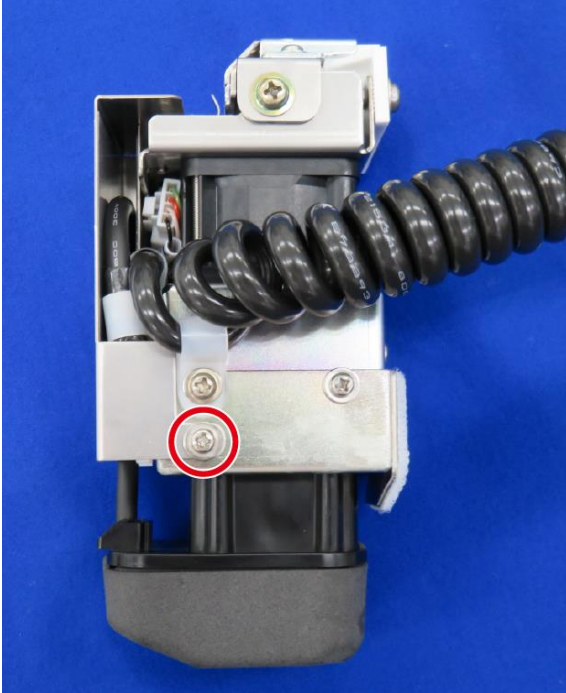

Disassembling the applicator unit

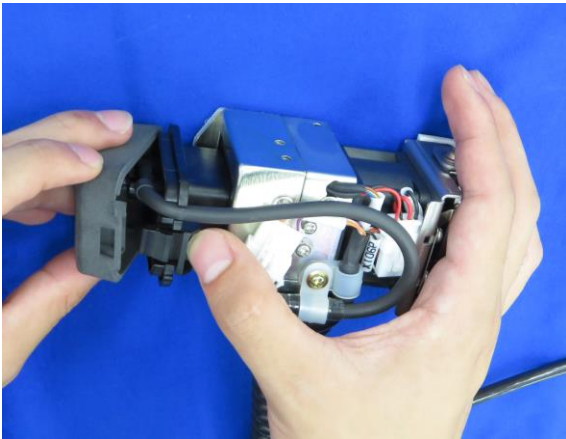

1. Remove the suction head.

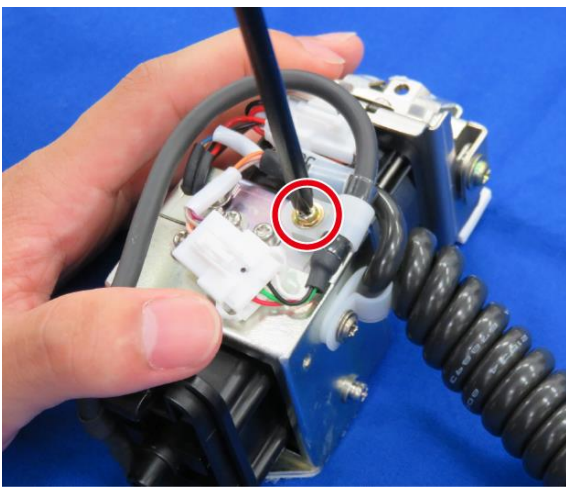

2. Remove a screw and a cable clamp.

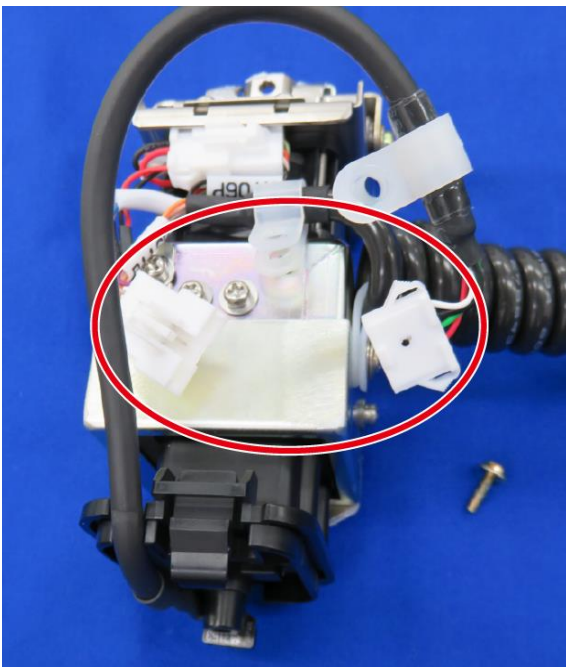

3. Unplug the connector of sensor cable wiring.

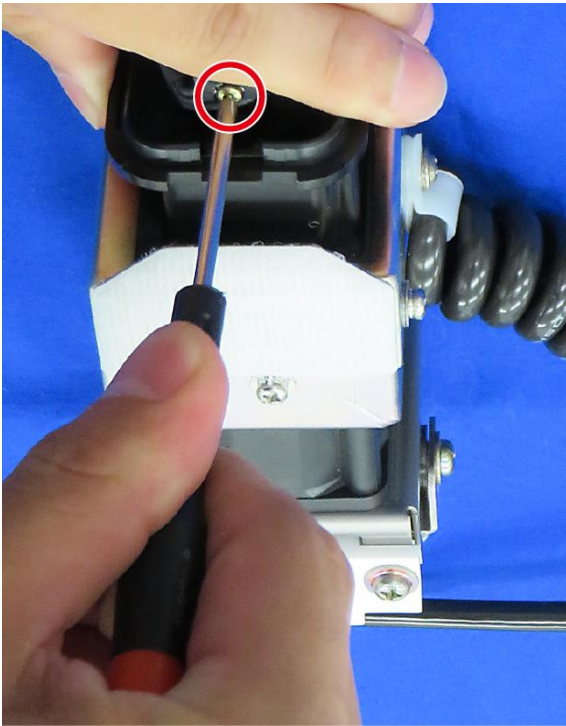

4. Remove a screw of sensor and a wire harness.

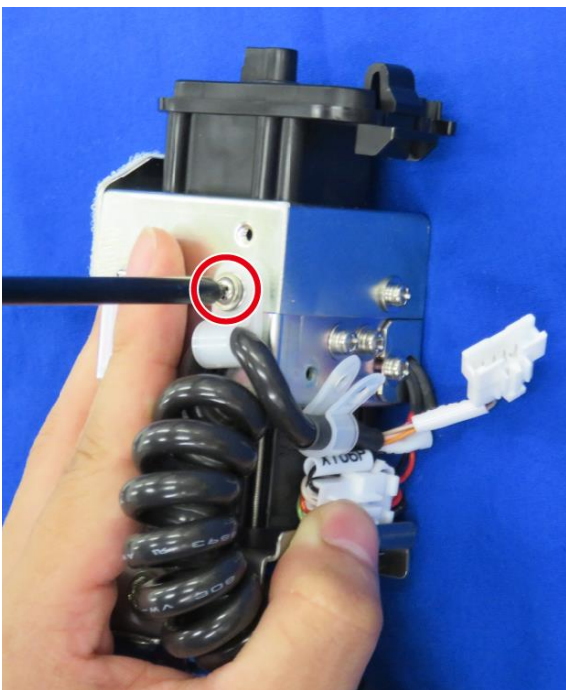

5. Remove screw and a cable clamp for the curled cord.

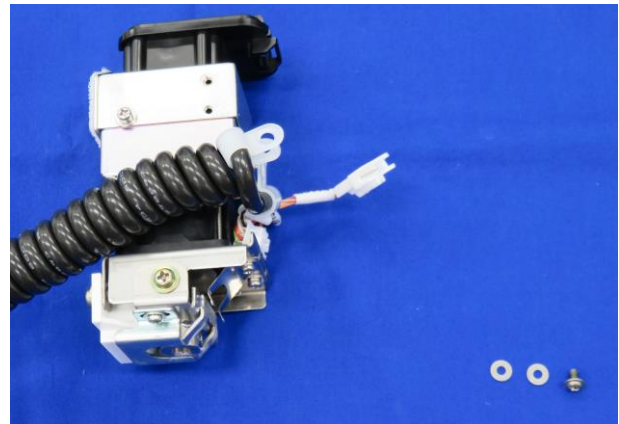

6. Unplug the connector of curled cord.

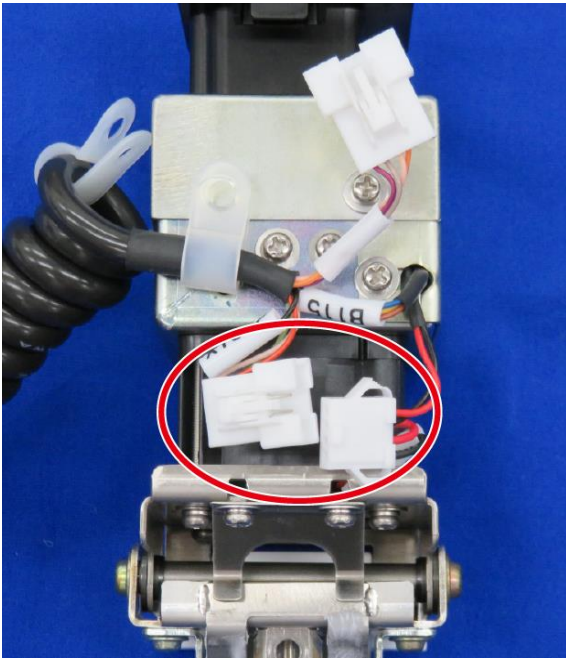

7. Remove two screws of both side of the sensor bracket and it.

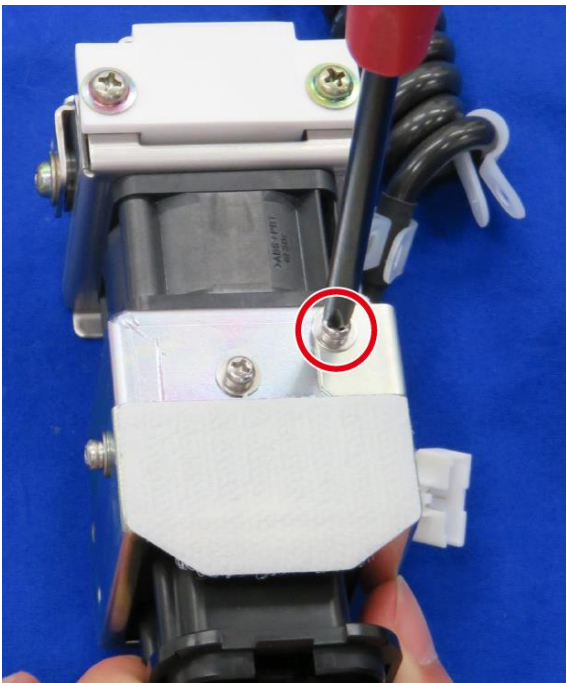
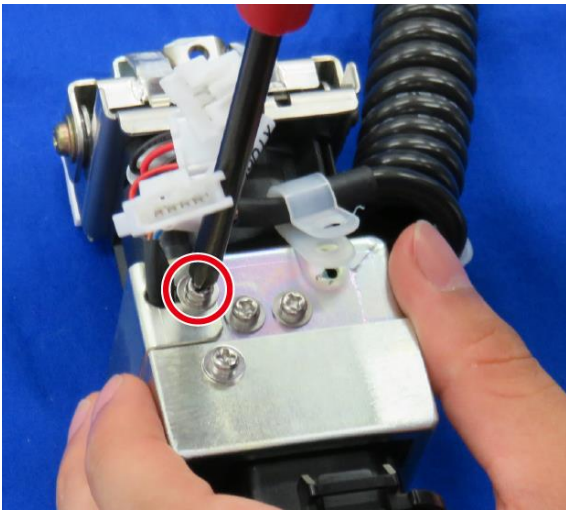

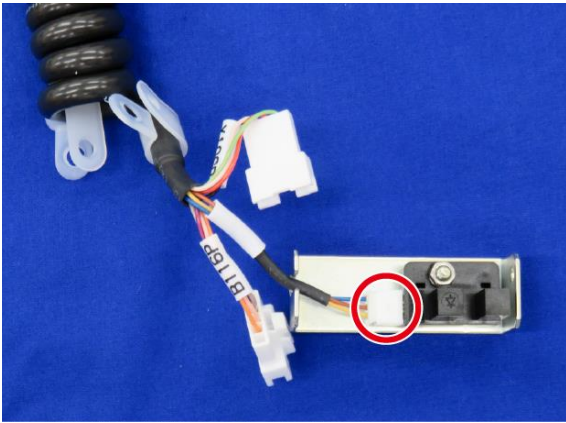

8. Unplug the connector to remove the sensor wiring. Check a curled cord is not damaged.

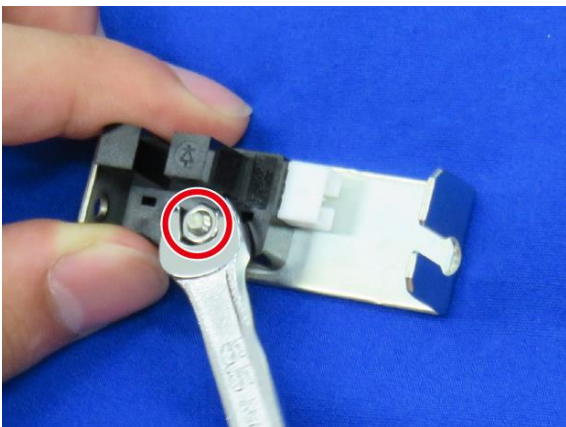

9. Remove a nut and a washer to pull off a sensor from the sensor bracket.

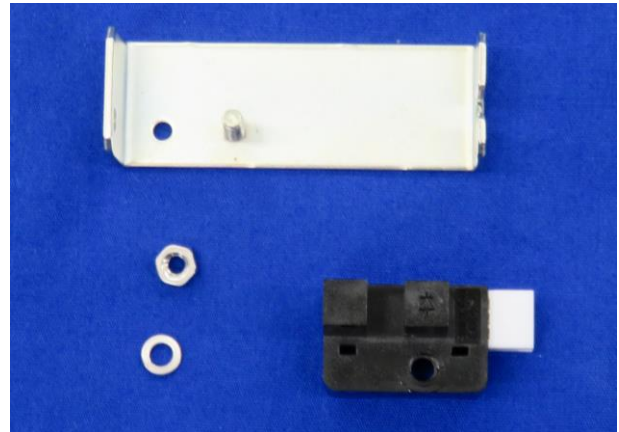

10. Remove two screws and a magnetic catcher.

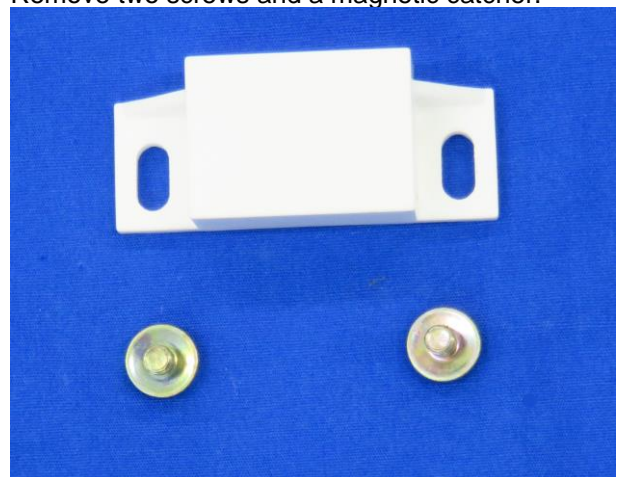

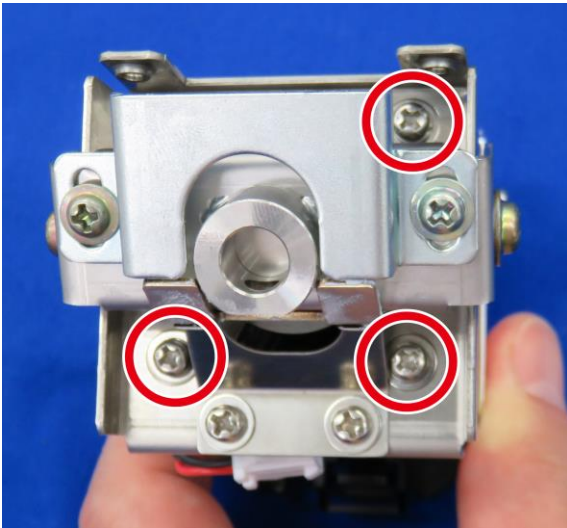

11. Remove three screws to take the assemble to pieces.

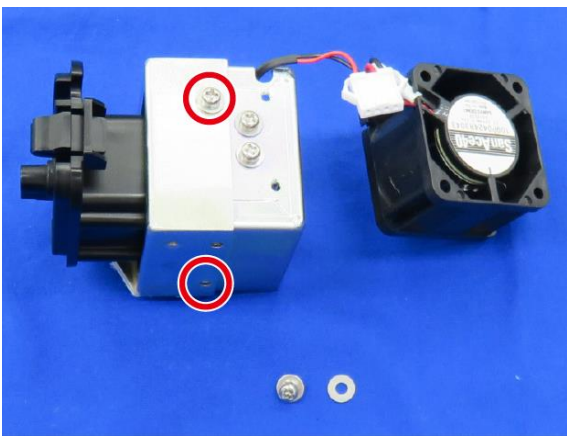
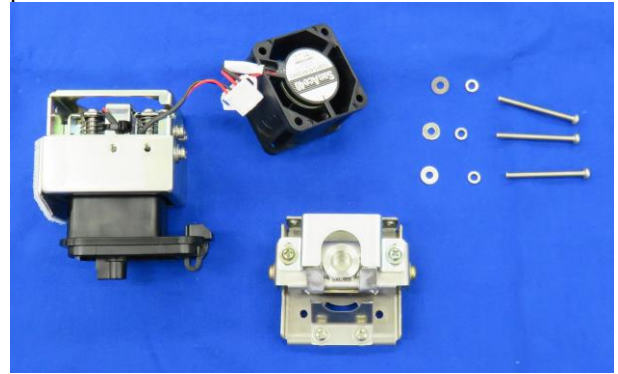

12. Remove two screws to separate upper and lower brackets.

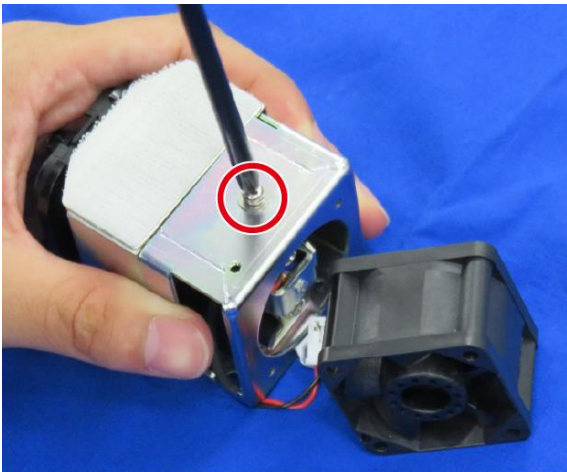
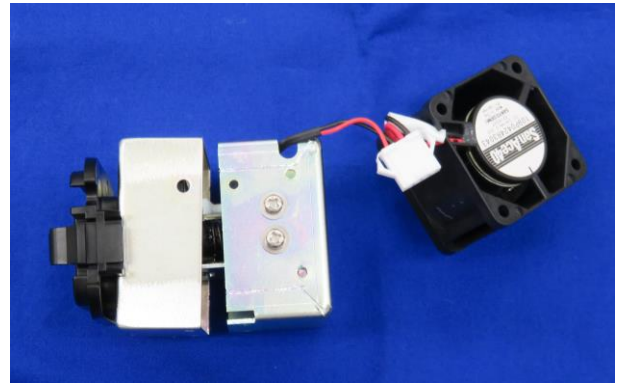

13. Remove three screws of both side of the bracket and it.

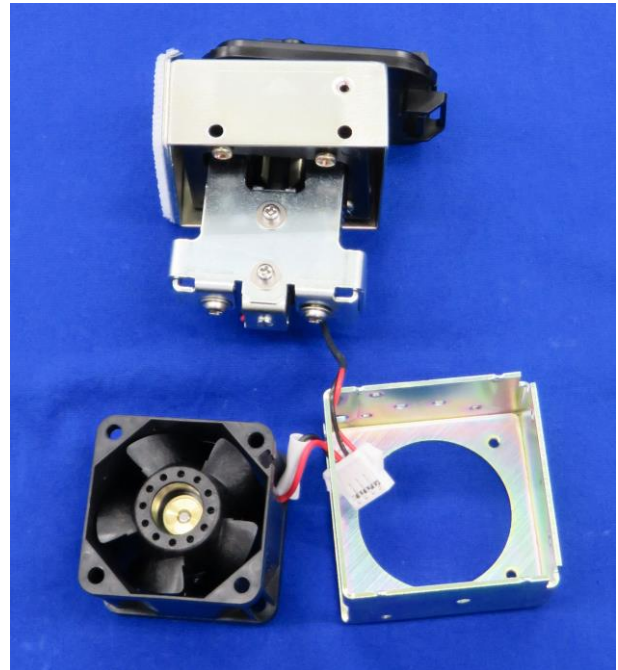
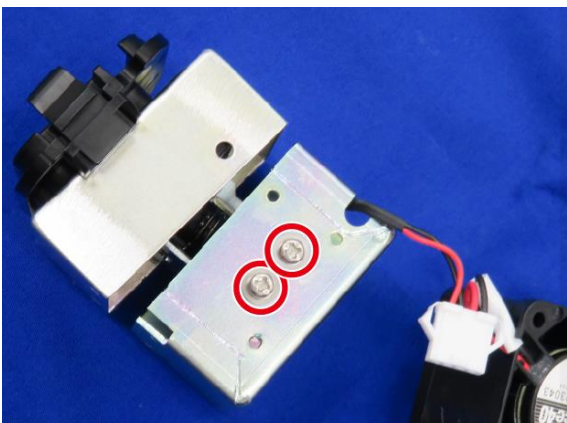

14. Remove two screws and the solenoid.

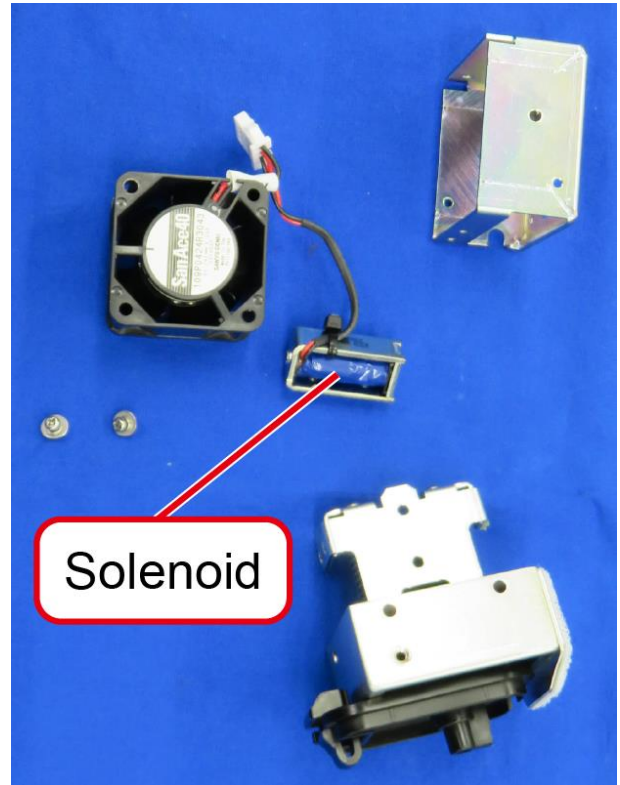
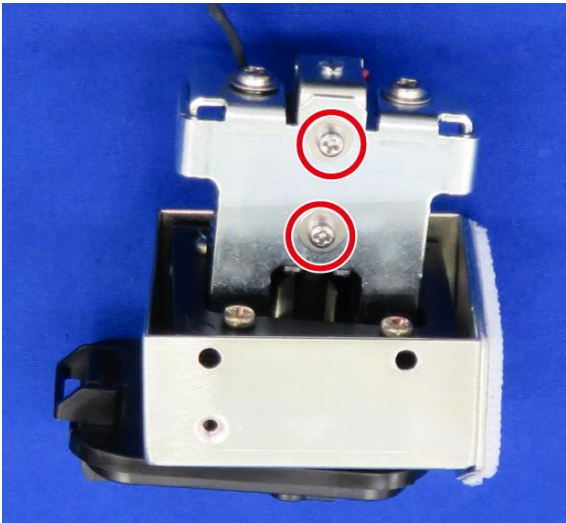

15. Remove four screws to take the assembly to pieces as shown in the figure.

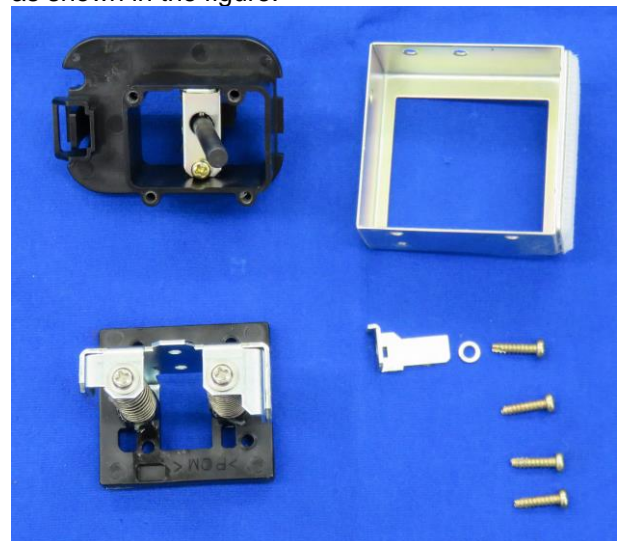
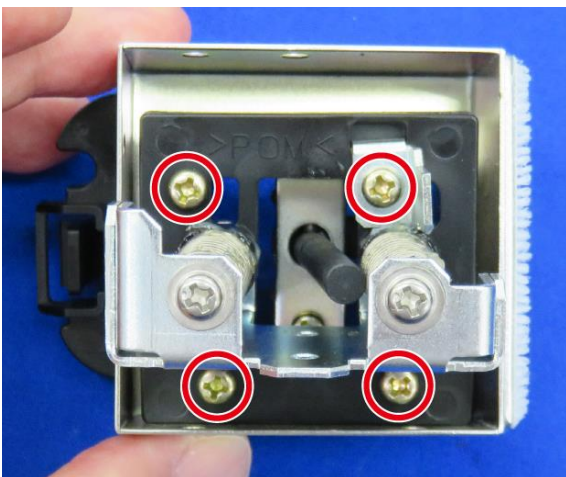

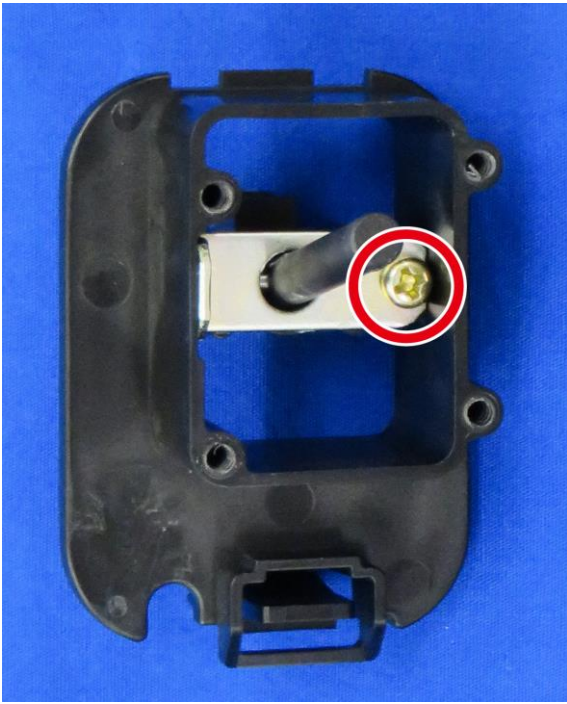

16. Remove a screw of the bracket and a solenoid core.

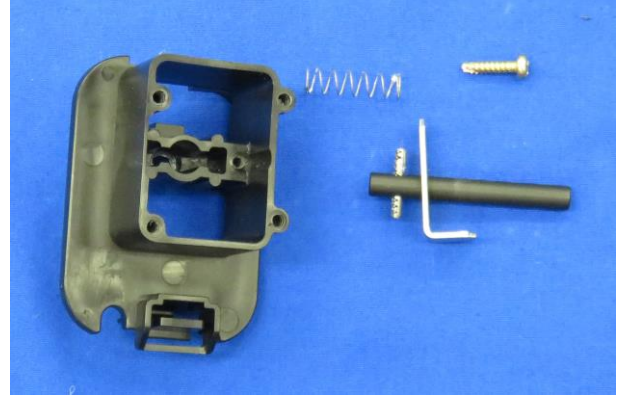

Clean up each parts.

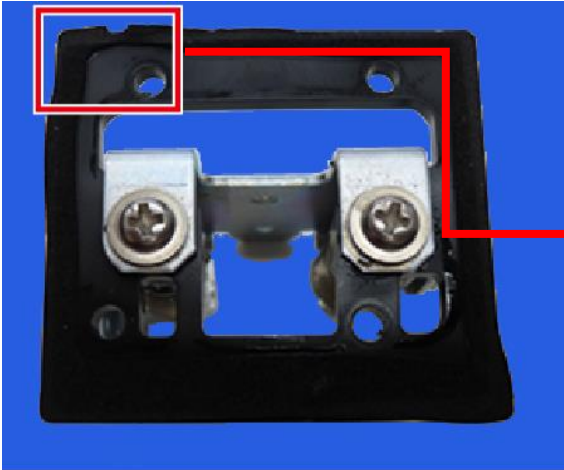

17. Check to determine whether to replace the gasket. An exchange of the gasket with deformation or break as shown in the figure is necessary.



18. Clean up springs and check the spring force.

Assembling the application unit

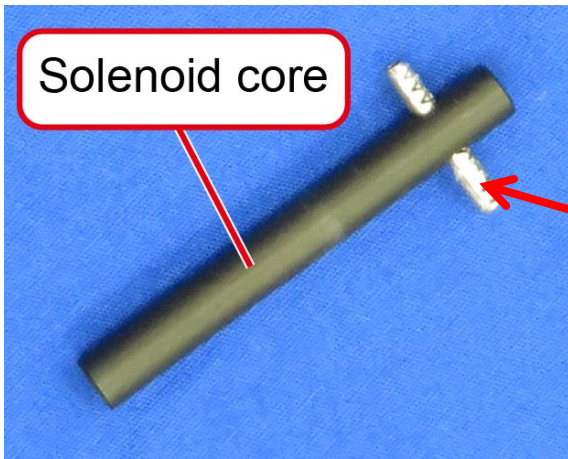

1. Push a spring pin into the center of the solenoid core.

Corrugated spring pin
SUS
M2 x 14

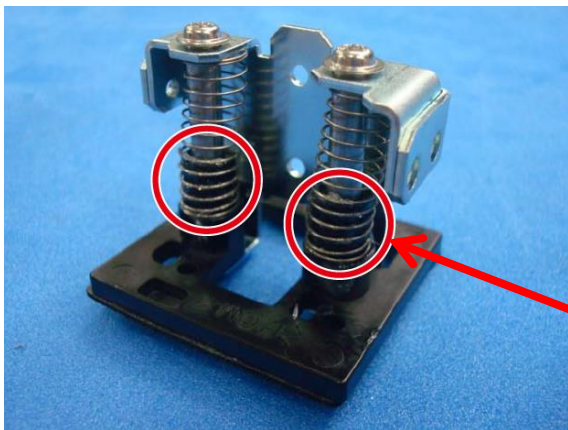

2. Apply the alvania grease at areas of springs as shown in the figure.

Alvania grease



3. Apply the white alcom grease at the part of pin inserting hole.

White Alcom Grease



4. Put on a spring to the hole.



Pan head tapping screw
Chromate finish
M3 x 12

5. Insert the solenoid core to hole of the bracket, then tighten with a screw.



6. Get rid of plastic shavings after screwing on the hole of backside.

7. Combine parts as shown in the figure.

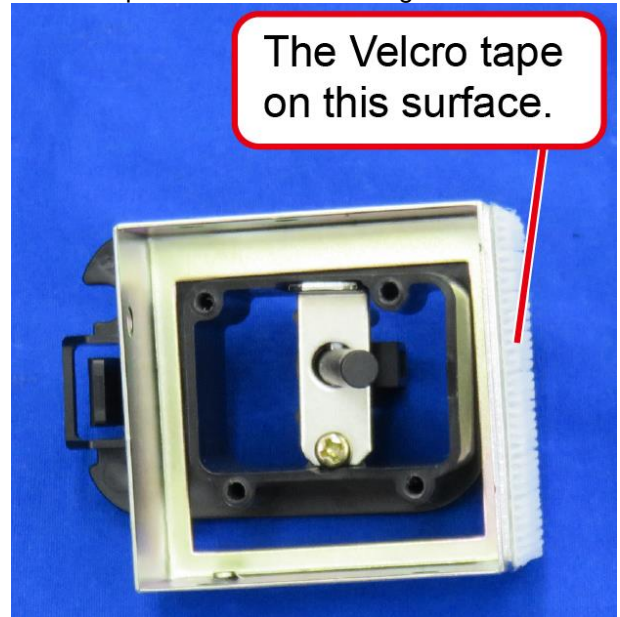
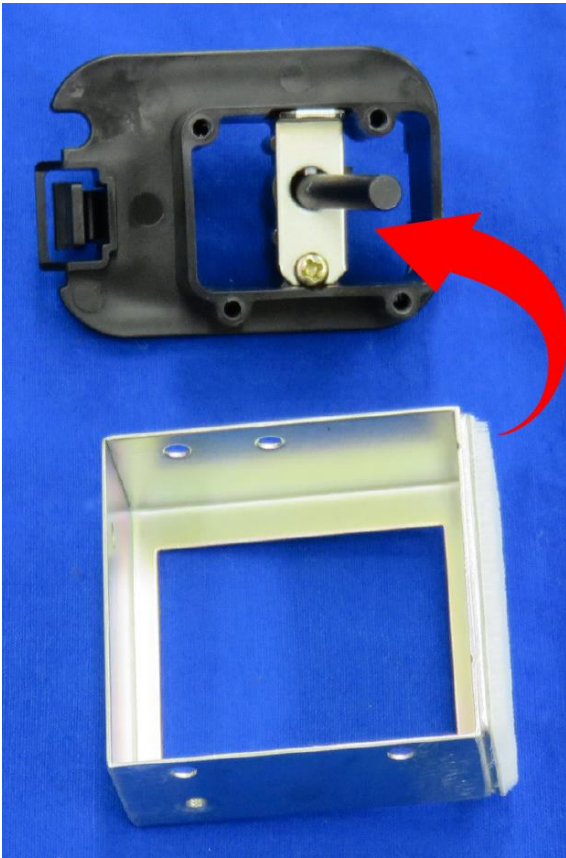

8. Combine parts as shown in the figure.

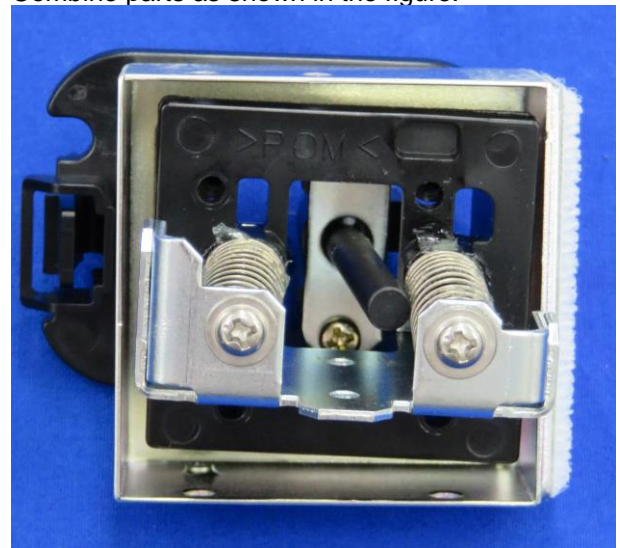
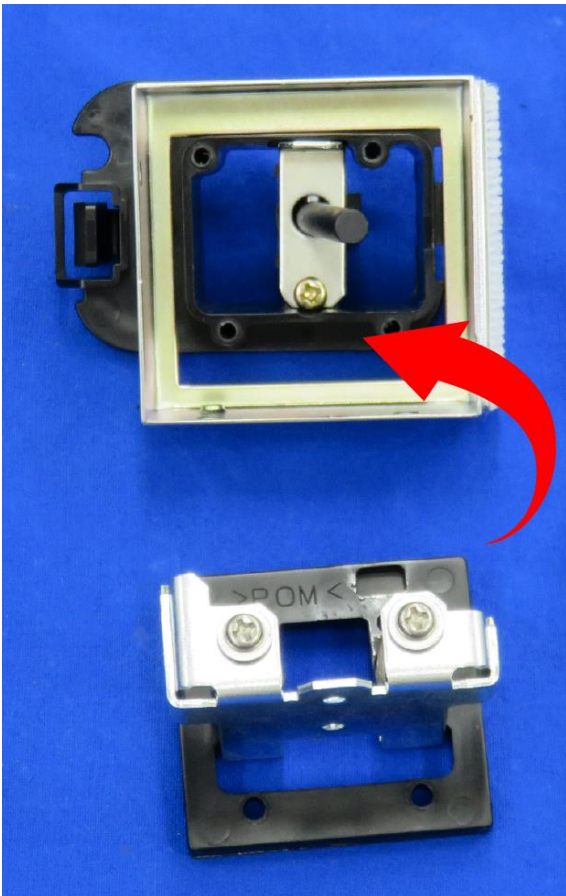

9. Screw four screws to attach the side of the bracket and the slide in parallel. In addition, tighten a screw with a spring washer for a detector.

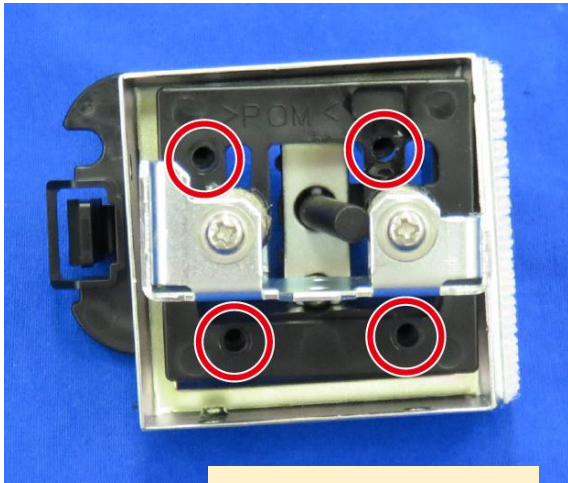

Pan head tapping screw
SUS
M3 x 12

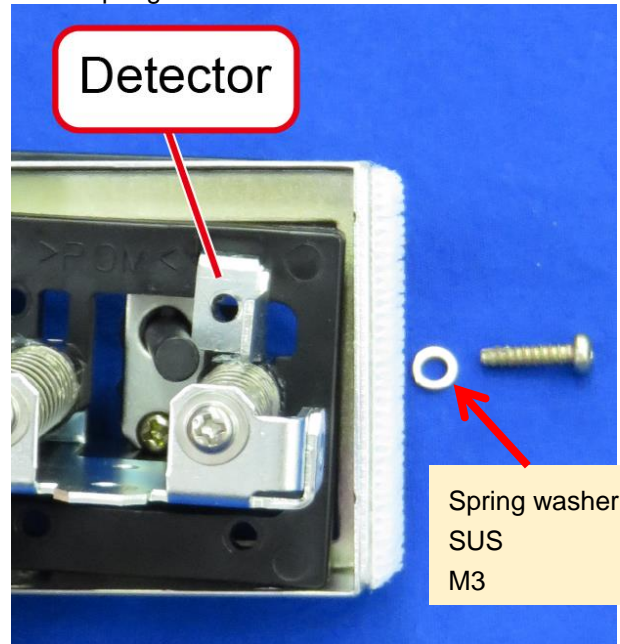

Spring washer
SUS
M3

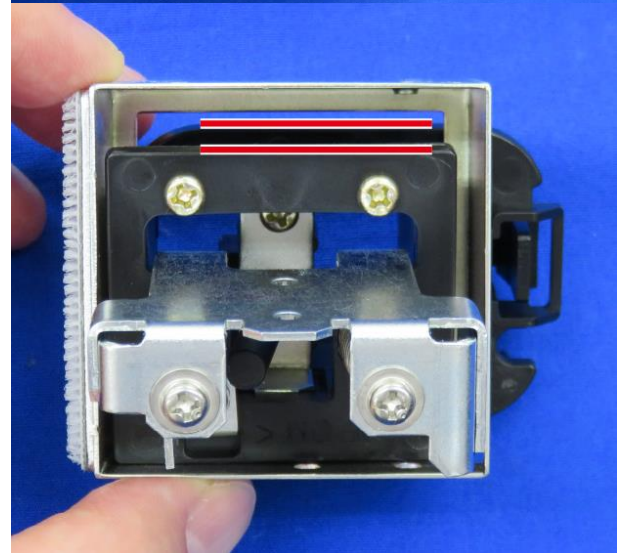

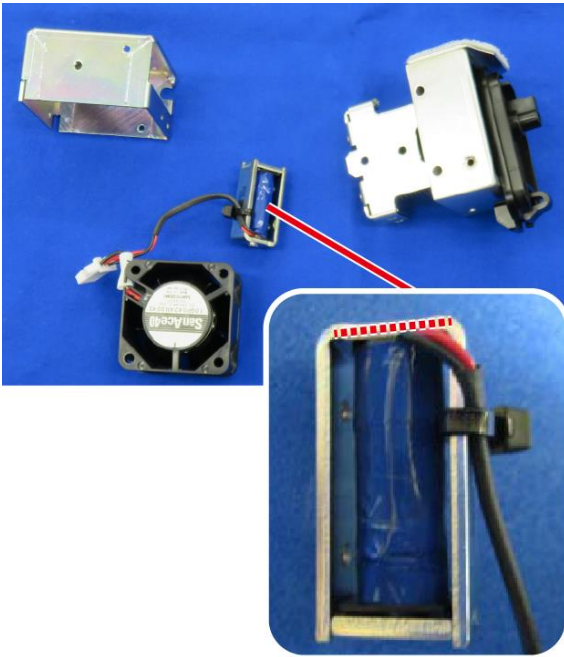

10. Insert the harness of solenoid inside the dotted line. Then insert a solenoid into the solenoid core by passing the harness of the solenoid through the bracket for a fan.

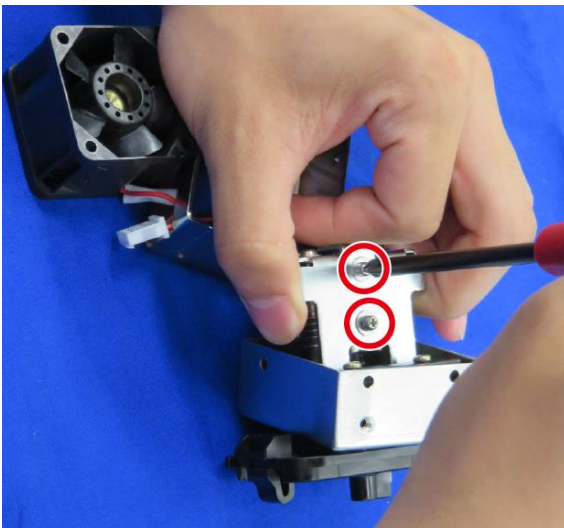
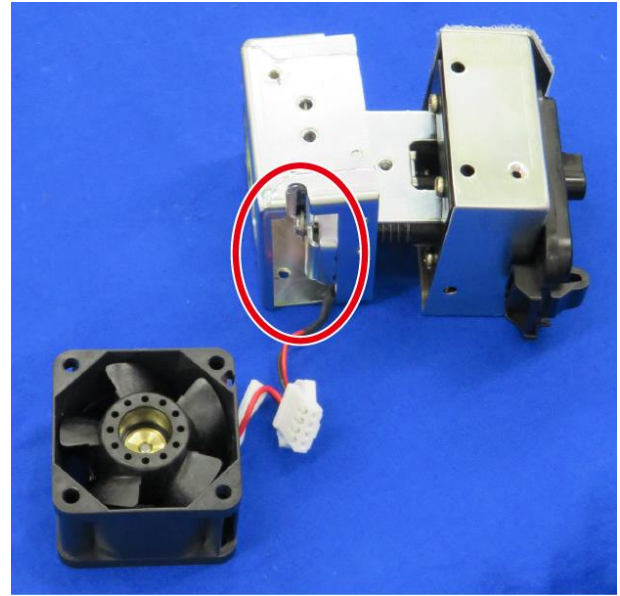

11. Screw two screws while pushing the solenoid downward.

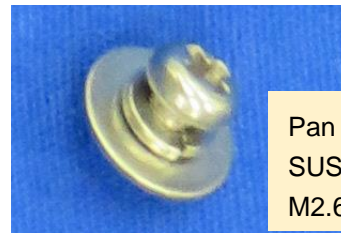

Pan head S2P2 screw
SUS
M2.6 x 4

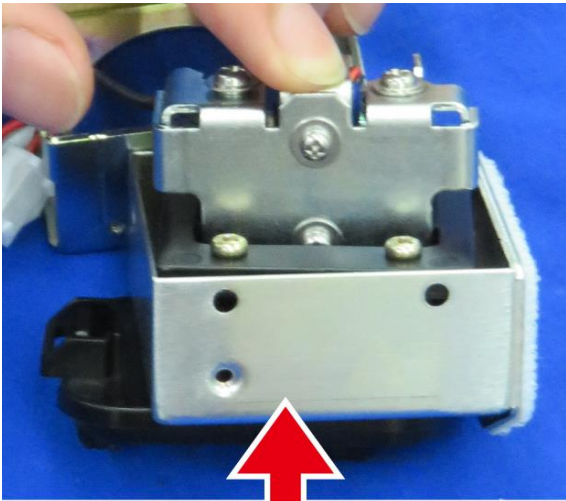

12. To check if the solenoid returns back smoothly, hold it in the downward position using your finger and release it.

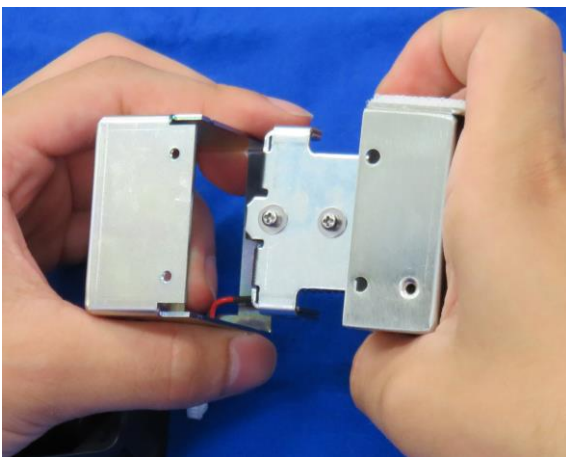
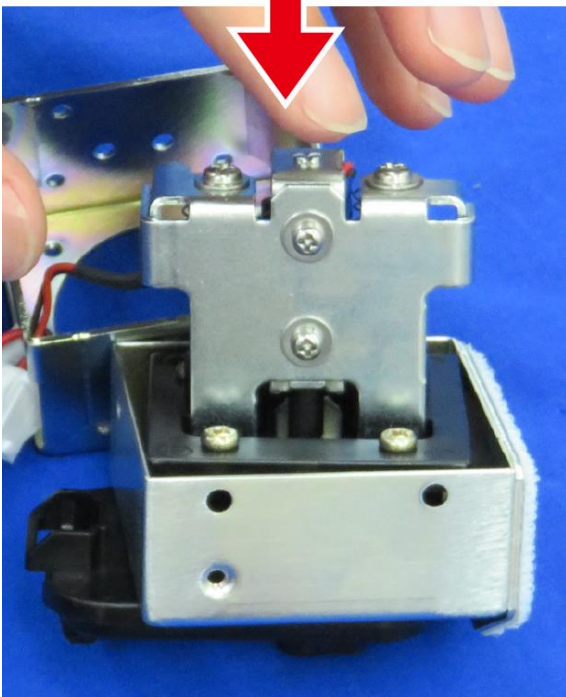

13. Combine upper and lower brackets.

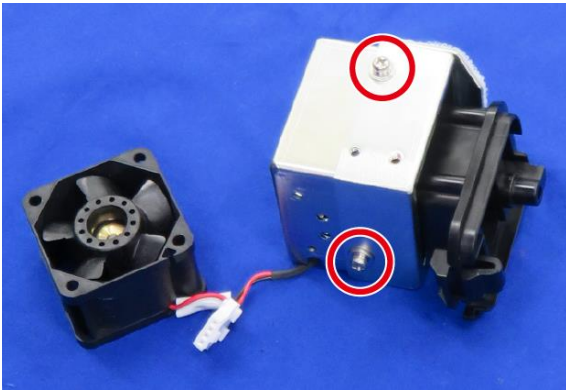

Pan head S2P2 screw
SUS
M3 x 4
Flat washer
SUS
M3

14. Screwing two screws with a flat washer to attach brackets in state that screw holes are cleared of play by separating two brackets.

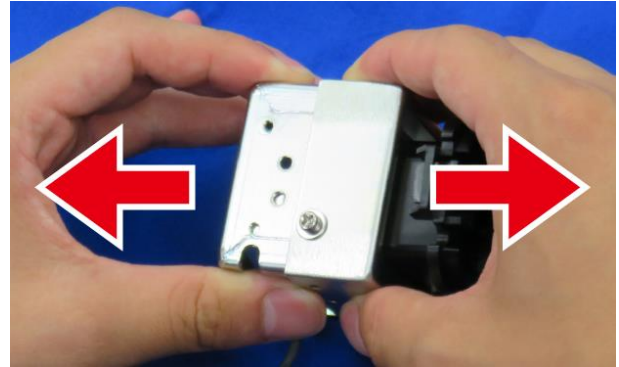

Check the length of screws before screwing and mounting.

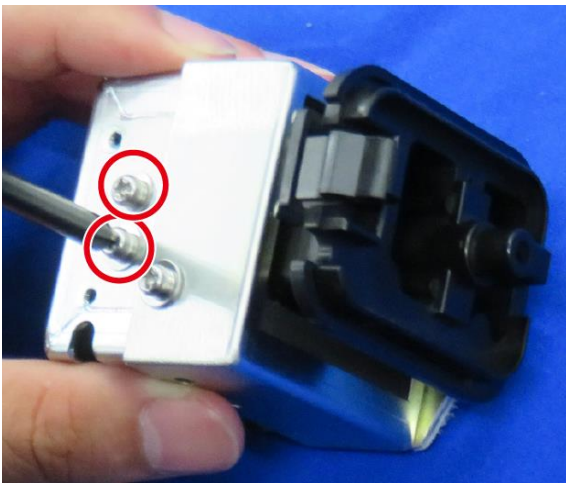
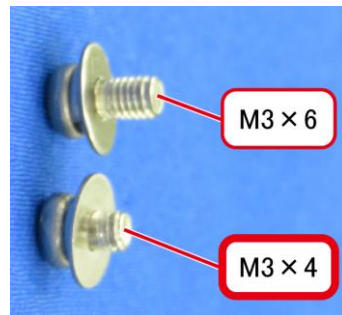

15. Screwing three screws.



Pan head S2P2 screw
SUS
M3 x 6



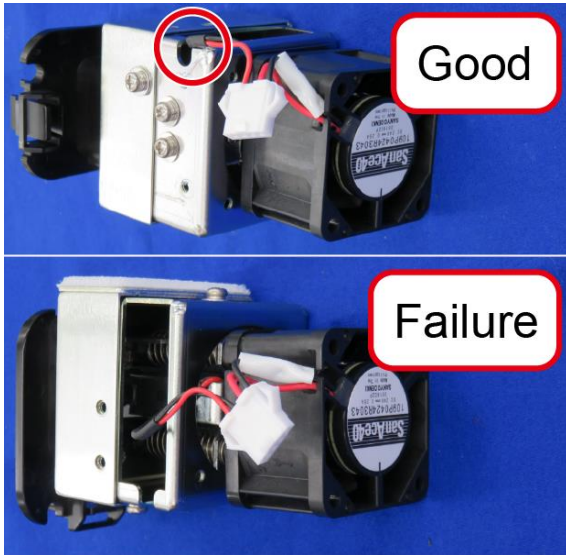

16. Combine the fan as shown in the figure.

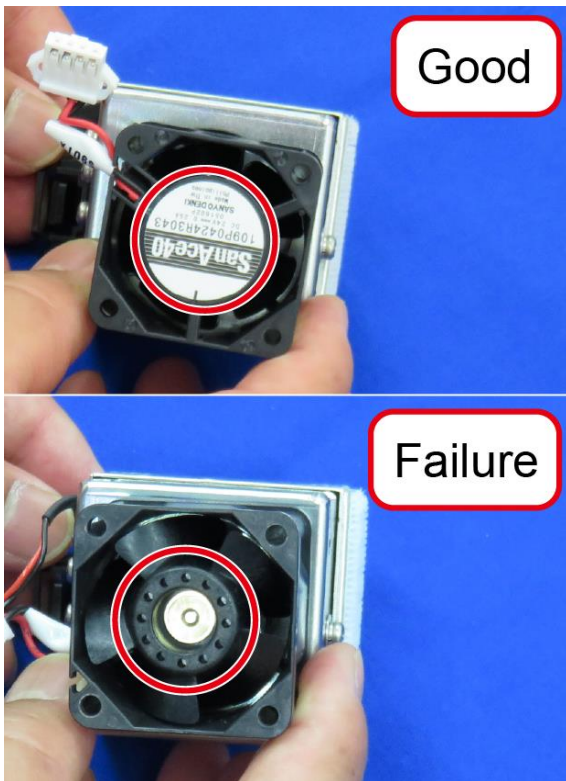

17. Put on the fan with the label surface up.

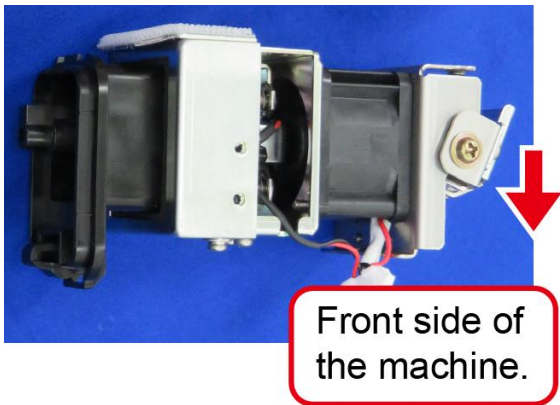

18. When the side of the suction bracket and the fan bracket are visually almost parallel, screwing three screws with a spring washer and a flat washer to attach.

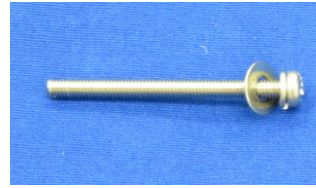

Pan head screw
SUS
M3 x 35
Spring washer
SUS
M3
Flat washer
SUS
M3

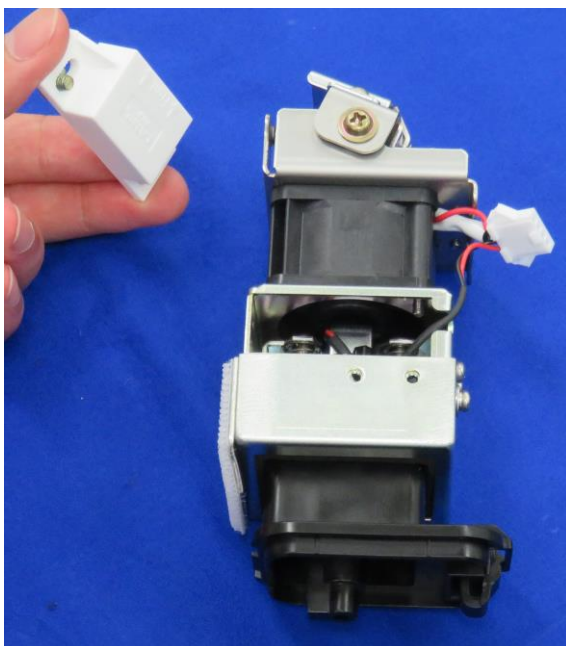
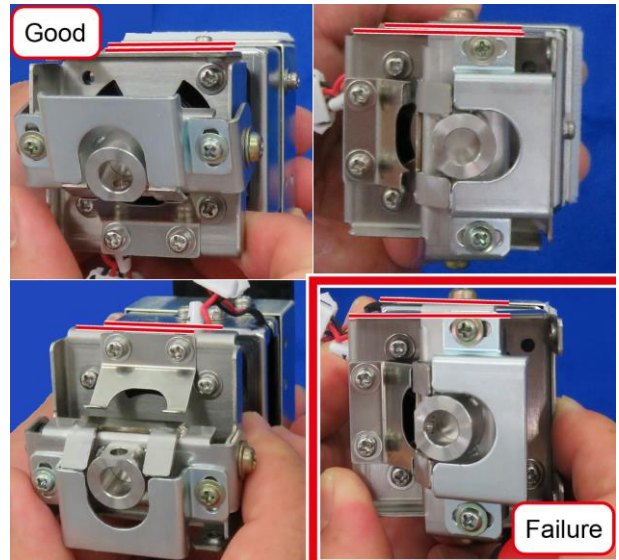
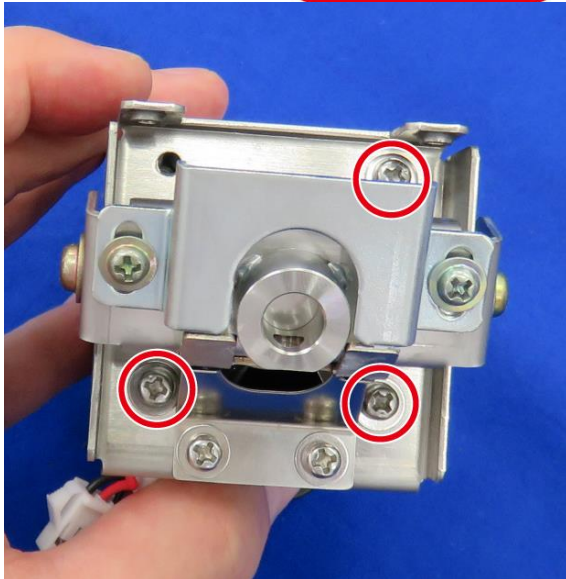

19. Screwing two screws to attach a magnetic catcher as shown in the figure.

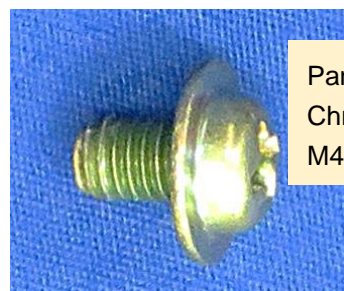
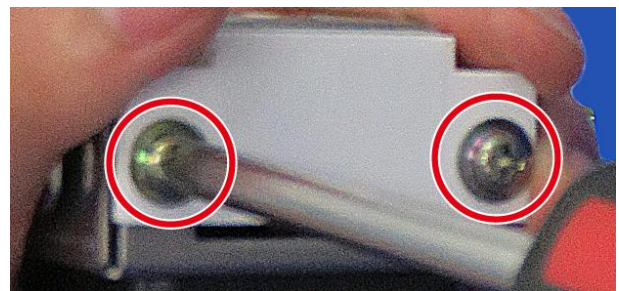

Pan head tapping locking screw
Chromate finish 2360
M4 x 6

Attach the sensor while slightly pushing in the direction of the arrow.

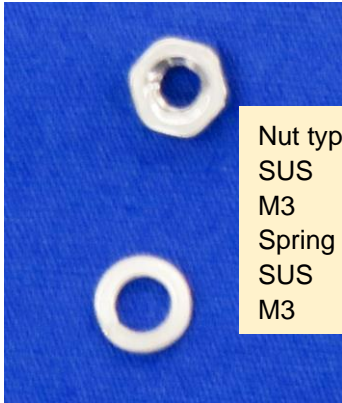
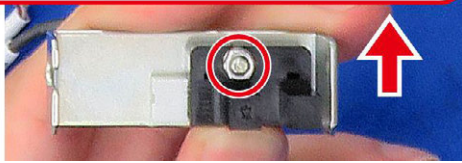

Nut type-1
SUS
M3
Spring washer
SUS
M3

20. Mount a sensor to the bracket with a nut and a spring washer. Then plug a connector.

The tag is positioned out of the bracket.

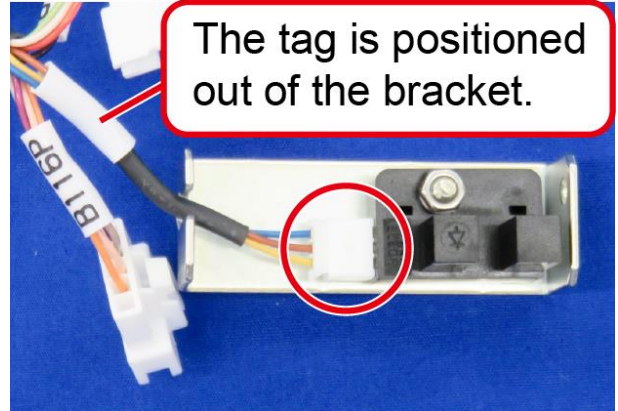

21. Screwing two screws to mount the sensor bracket. The harness through a notch of the sensor bracket.

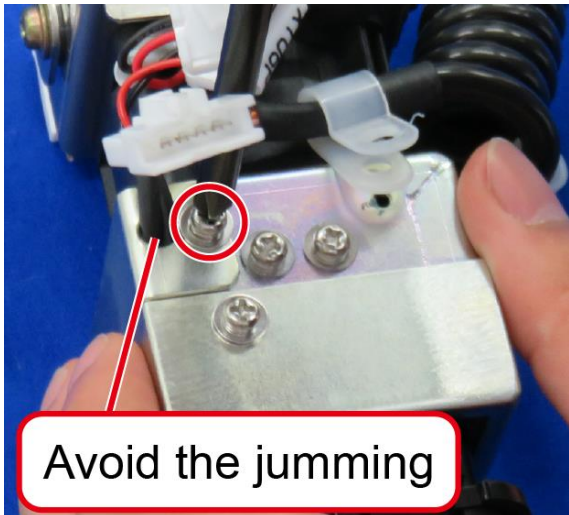

Avoid the jumming



Pan head S2P2 screw
SUS
M3 x 4

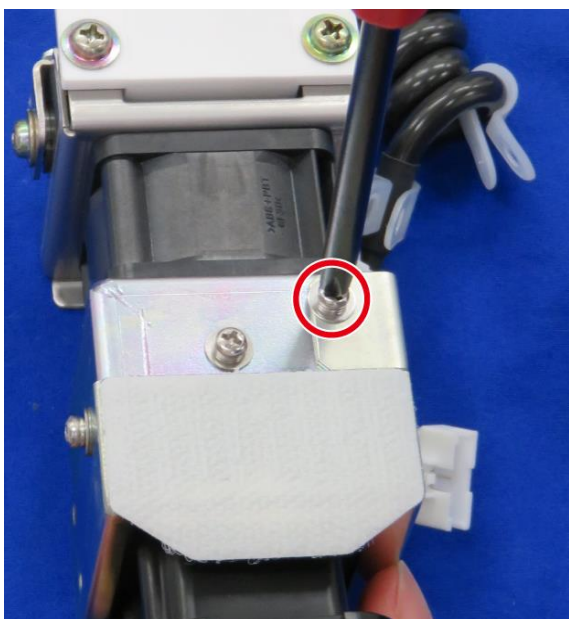

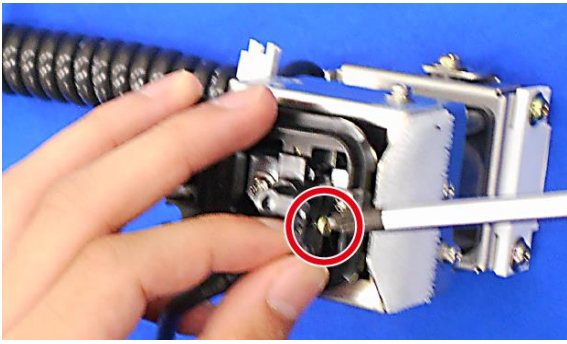

Apply the agent 1401B to prevent screw loosening, leaks, and rust.

22. Apply the locking agent on threads of screw, then screwing a screw to mount a sensor.



To mount a harness without applying any unreasonable force.

Binding tapping screw
Chromate finish
M2 x 8



23. Put the suction head on.

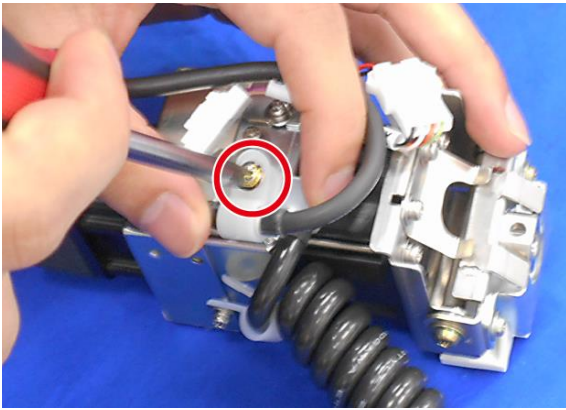

Holding flexible tube

Flat surface at upper

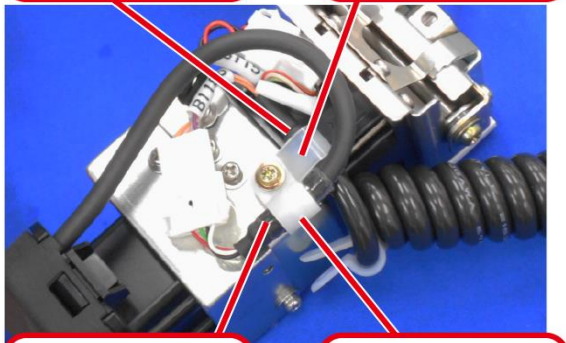

Holding flexible tube

Flat surface at lower

24. Plug a connector then screwing a screw applied the locking agent on threads to attach two cable clamps as shown in the figure. To mount two clamps holding flexible tube area of cords.

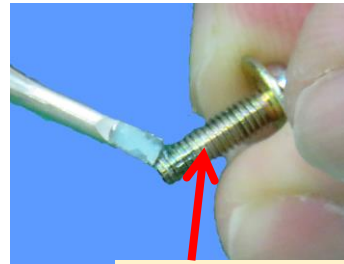

Pan head tapping screw

Chromate finish

M3 x 10

The Agent (1401B) to prevent screw.

To mount the connector such a position as not to interfere with the suction unit as shown in the figure.

Good

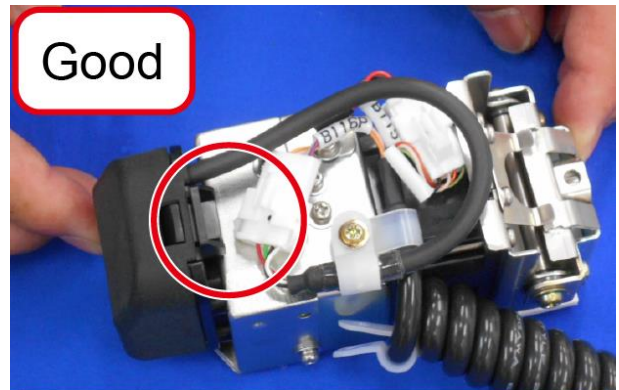

Failure

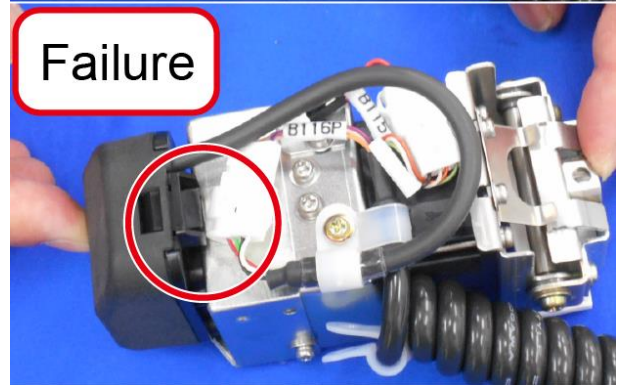

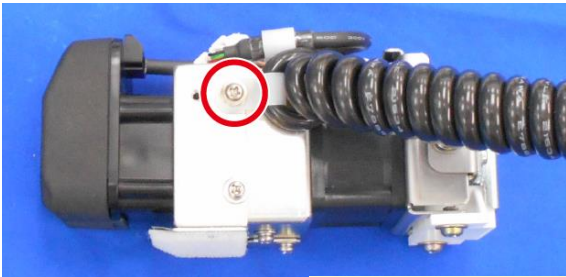

25. Screwing a screw with two flat washers to attach a clamp for a curled cord as follow.
- Screw
 - Two flat washers
 - Cable clamp
- To mount a winding start of curled cord.



Pan head tapping locking screw
SUS 2360
M3 x 6
Flat washer
SUS
M3

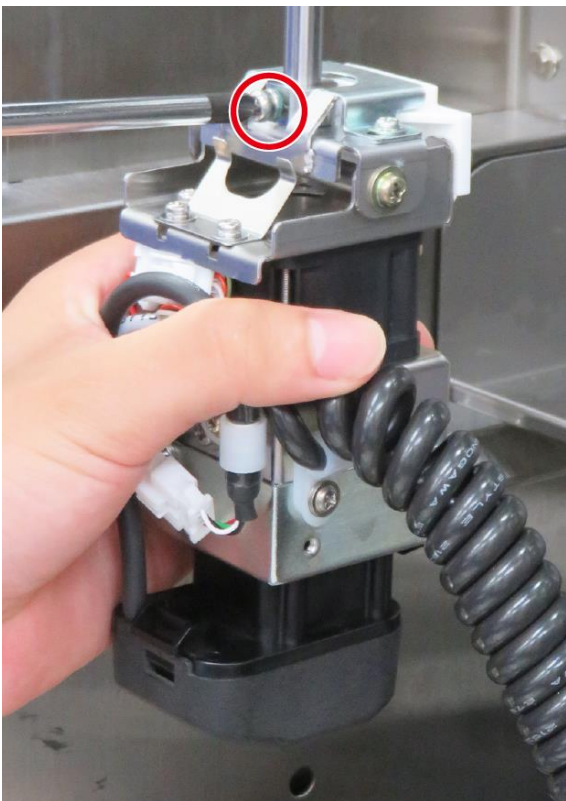

26. Attach the applicator unit to the shaft. Then tighten a screw after rotating the shaft to the position as shown in the figure.

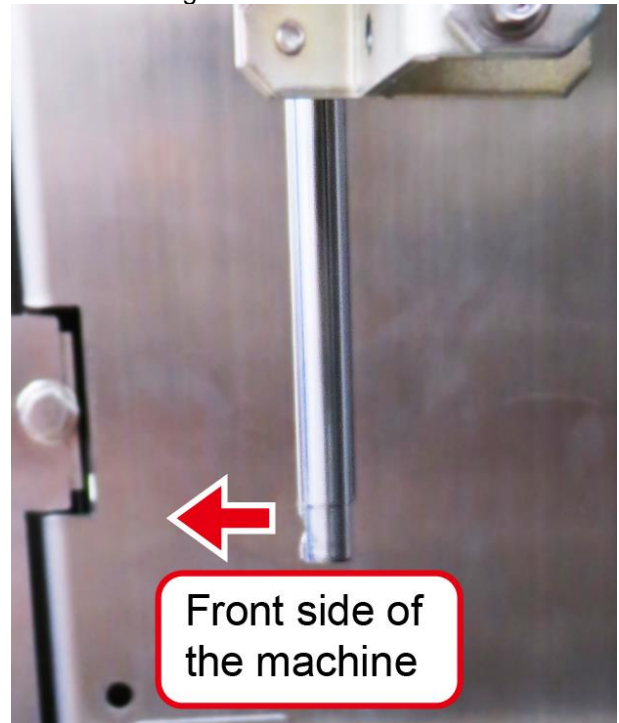

Pan head S2 locking screw
SUS 2360
M4 x 10

27. Screwing a screw to mount a cable clamp for a curled cord.

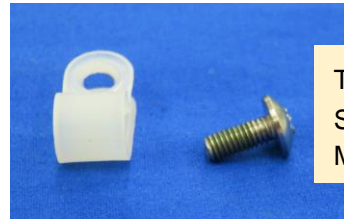
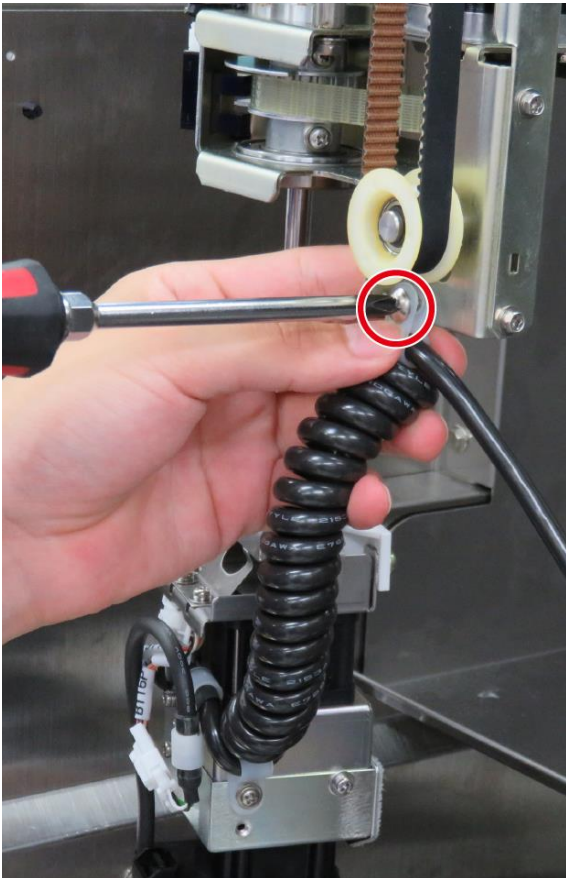

Truss head locking screw
SUS 2360
M4 x 10

To mount flat surface of cable clamp at forward and to attach positioned of curled cord at seventeen turns.

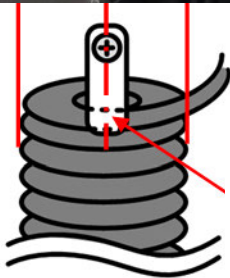

To mount a clamp at position of center of curled cord.

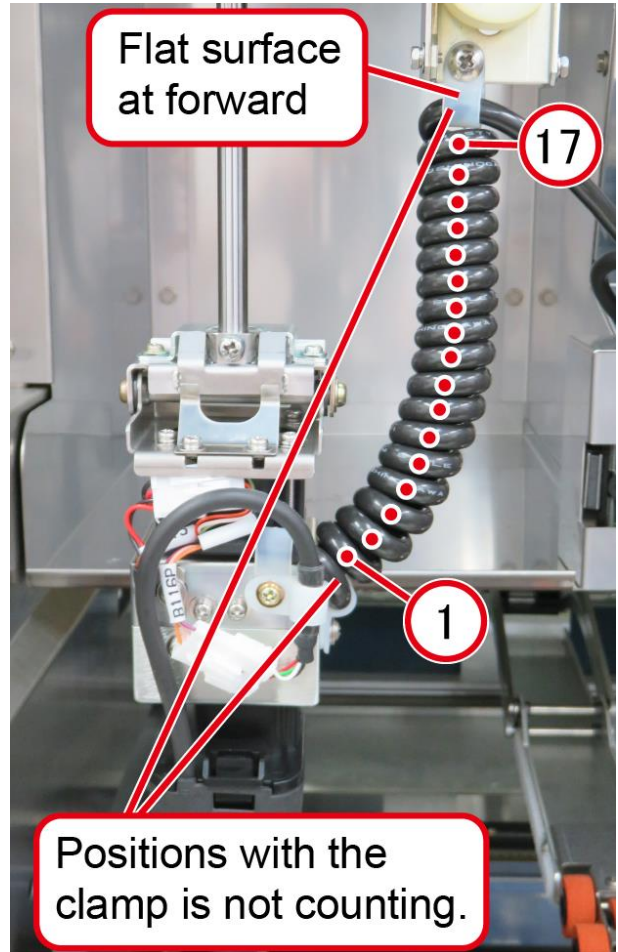

28. Plug the connector for the curled cord.

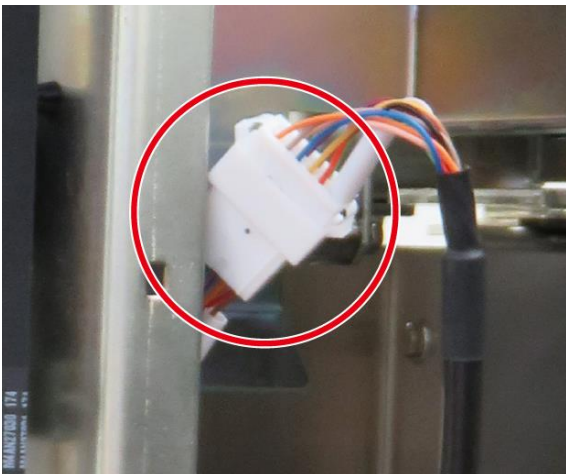

29. Attach a curled cord with three tying bands. Then the cord inserts to the cord holder.

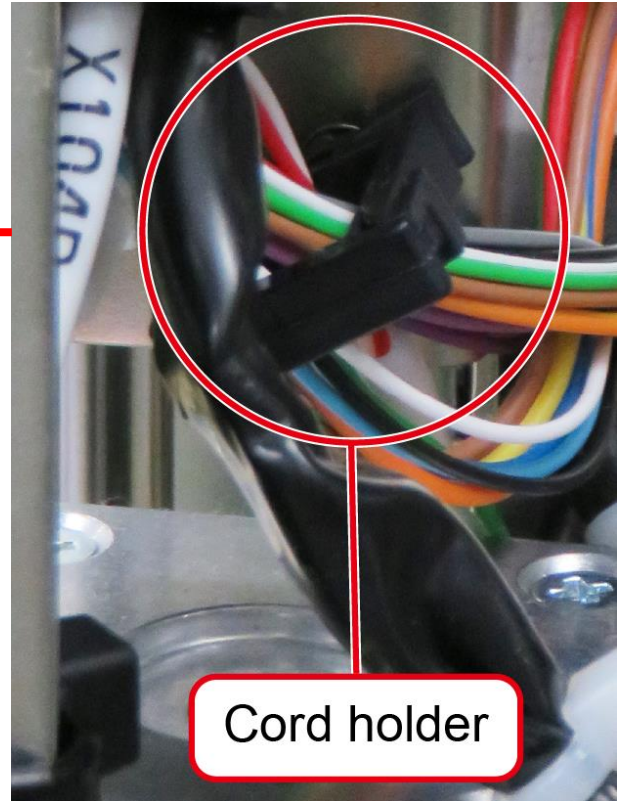
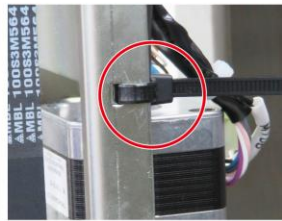
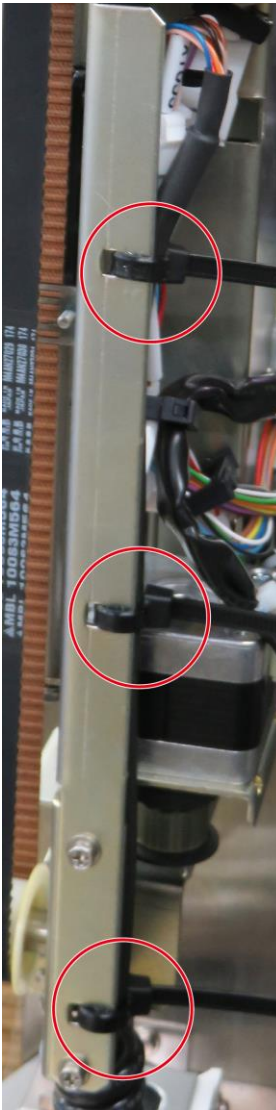

Cord holder

By inserting a tying bands into holes of the frame as shown in the figure.

The locks of tying bands hold inside of the stay of the frame as shown in the figure.

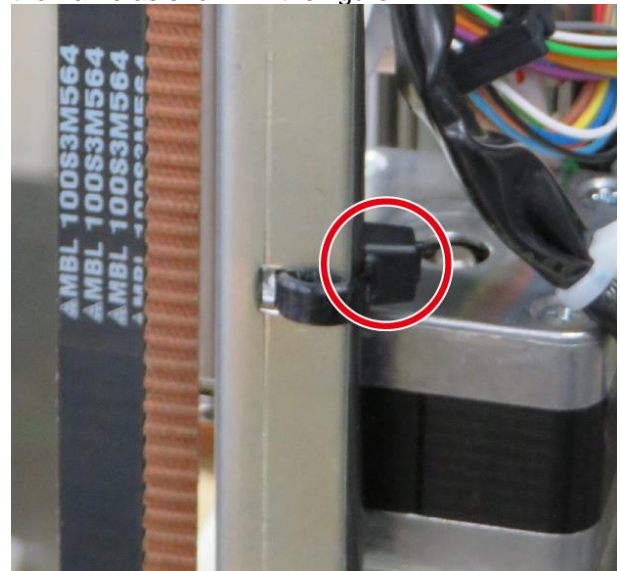

Adjusting after replacement

1. The applicator unit may rotate to press by the curled cord mounted failure.

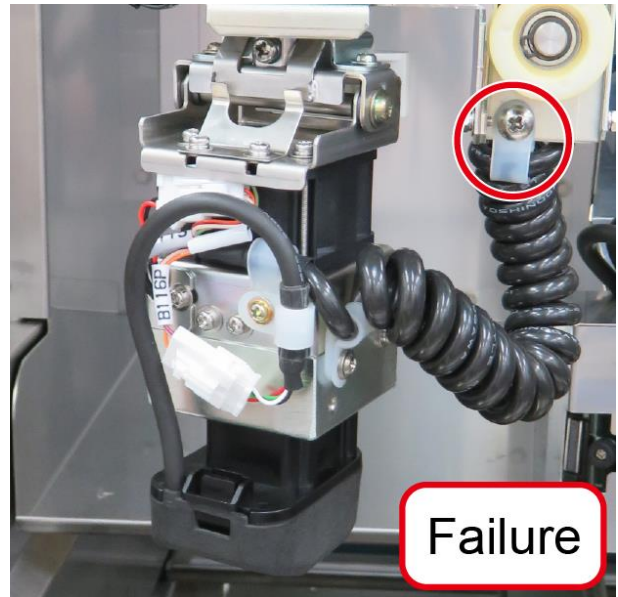
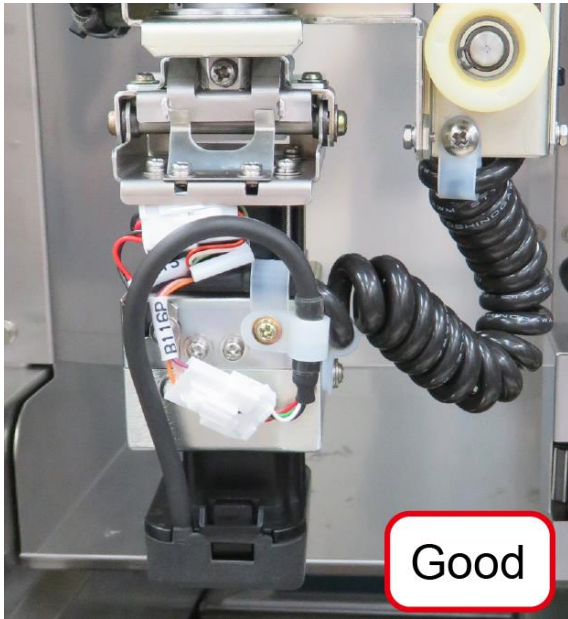

Adjust to change a mounting position of the cable clamp for a curled cord when the applicator unit is rotated by initial force of curled cord.

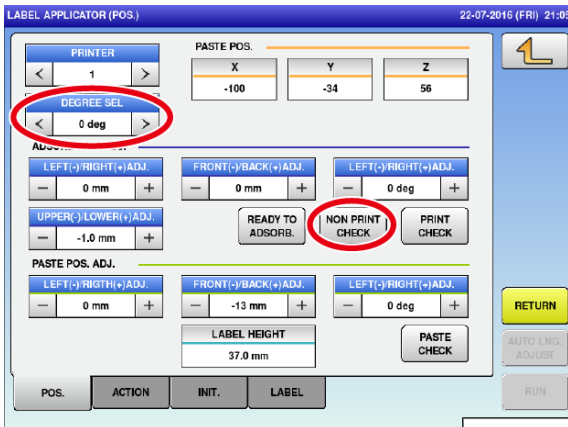

2. Touch [ADJUST] button -> [LABEL APPLICATOR] button -> [POS.] tab, select [0 deg] and [NON PRINT CHECK] button to move down the suction head then check the suction position between the head and O-rings of standby roller.

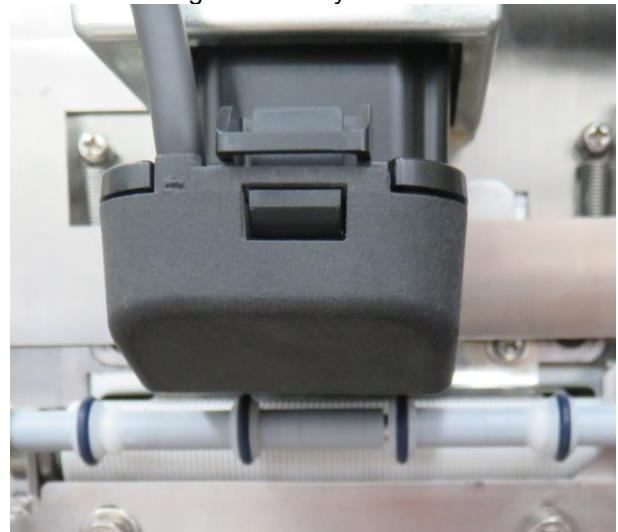

Adjust to lose and tighten three screws to attach symmetry when spaces of left and right are asymmetry.

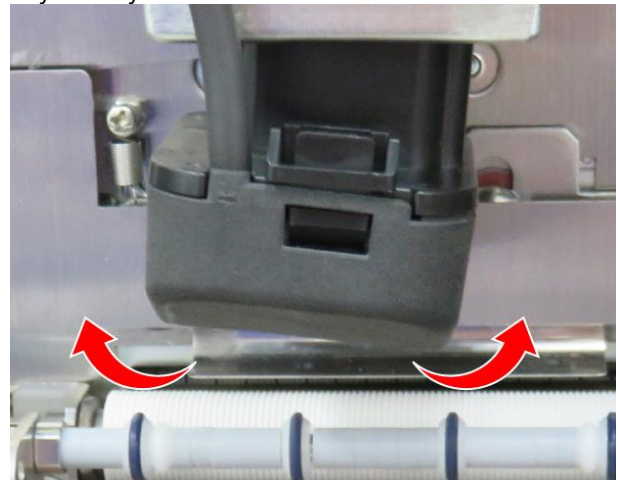

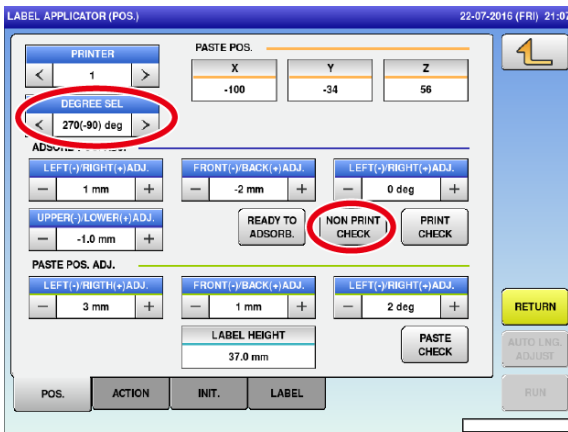

- Also, select [270(-90) deg] and [NON PRINT CHECK] button to check the suction position between the head and O-rings of standby roller.



Adjust to lose and tighten two screws to attach symmetry when spaces are asymmetry by a similar procedure.





4. Mount the applicator unit cover after the cable insert a middle partition area.

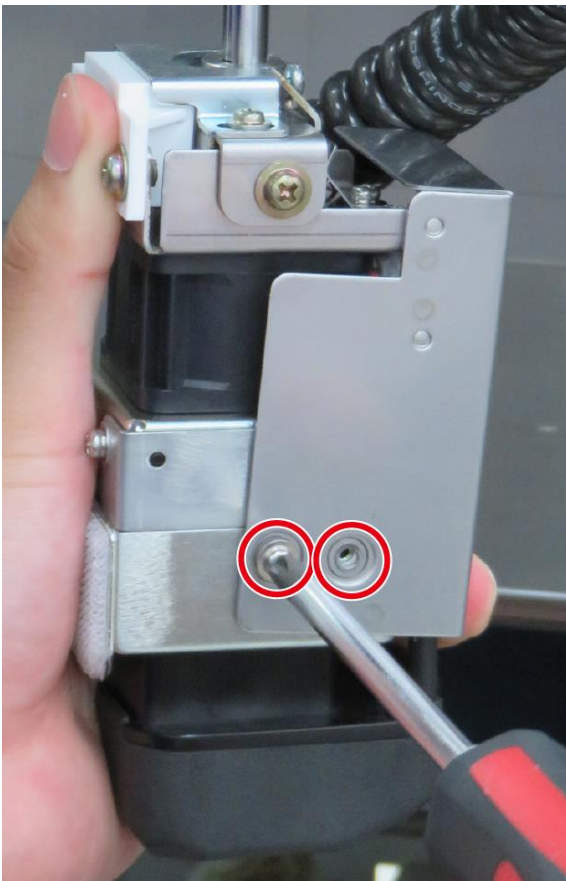

5. Screwing two screws on left side of the unit to attach the cover.



Pan head tapping locking screw
SUS 2360
M3 x 4

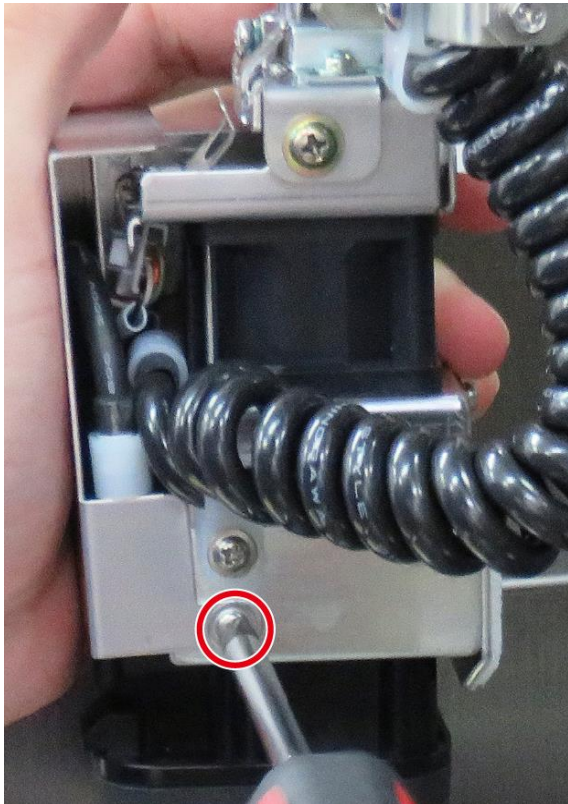

6. Screwing a screw with two flat washers on right side of the unit to attach the cover.

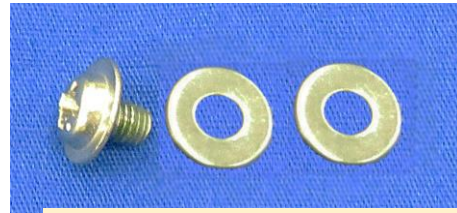

Pan head tapping locking screw
 SUS 2360
 M3 x 4
 Flat washer
 SUS
 M3

There was only one washer when remove the screw, then screwing a screw with a flat washer and check the suction head smoothly to return back when release pushing. Remove them and screwing again with two washers when motion of the suction head is not smooth.

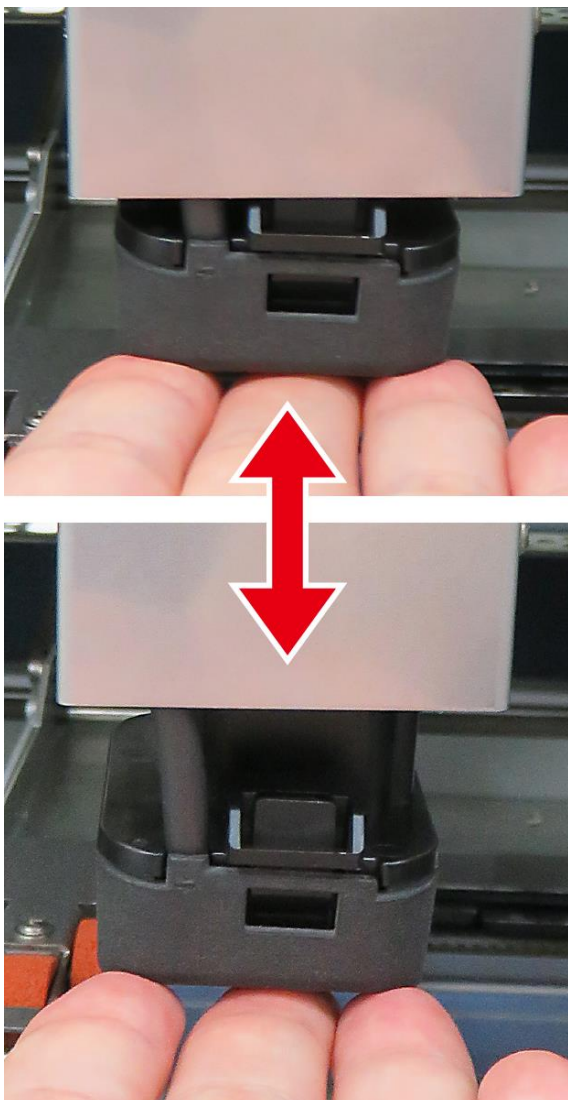

7. To check the suction head smoothly to return back when release pushing. Review the presence/absence of washer or the length of screws for assembling when motion of the suction head is not smooth. Also, check the suction position between the head and O-rings of standby roller again.

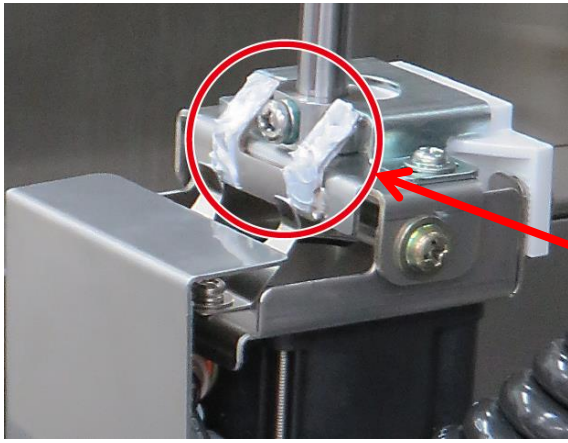

8. Apply the white alcom grease at points as shown in the figure.

White Alcom Grease



9. Mount a cover of the applicator unit.

2.3.3 Feeder Unit

- Remove the feeder unit from the right-hand side.
- To attach the unit, perform the procedure in the reverse order.

2.3.3.1 Preparation

- 1) Turn off the main power supply.
- 2) Remove the removal cover for the right film.

2.3.3.2 Removing the front feeder

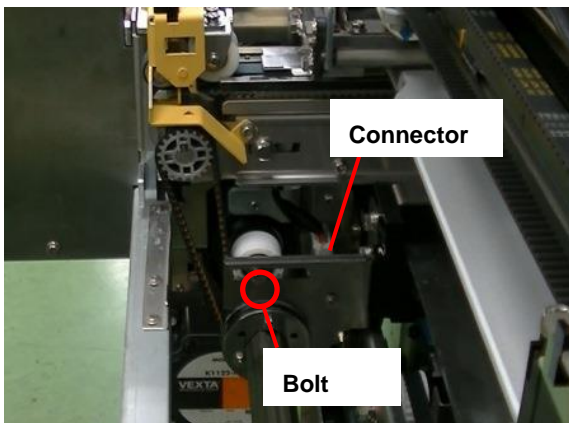

1. Shift the side wrapping plate into the center.
2. Loosen the screw of the tension pulley that attaches the driving belt on the front feeder, and slide it to remove the belt.
3. Remove the connector.

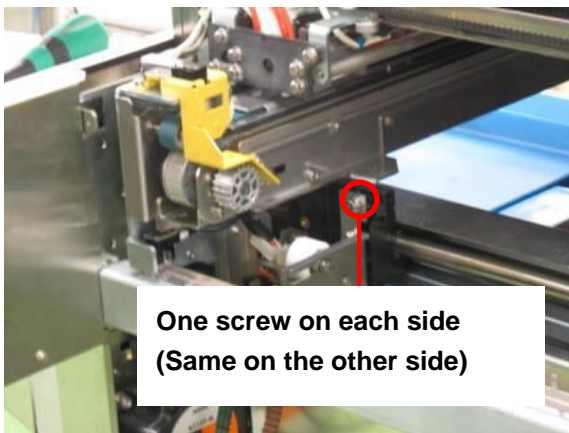

4. Remove the two screws fixing the front feeder on both ends.

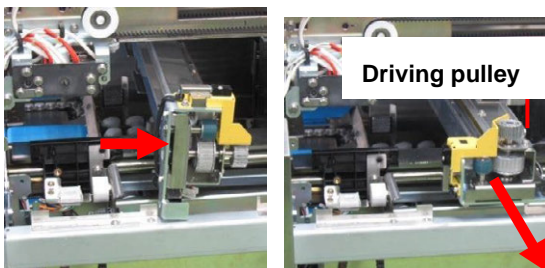

5. Slide the front feeder in the back position, lay down the front feeder so that the driving pulley faces up, and then remove the front feeder.



INFORMATION

Use the same procedure to remove the rear feeder.

2.3.3.3 How to replace the feeder belt

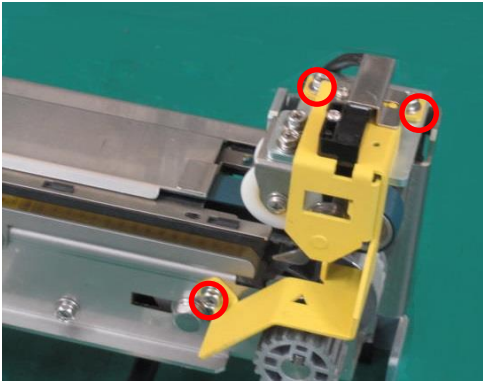

1. Detach the bracket by removing the three screws fixing the bracket.



2. Remove the harness of the detection sensor.

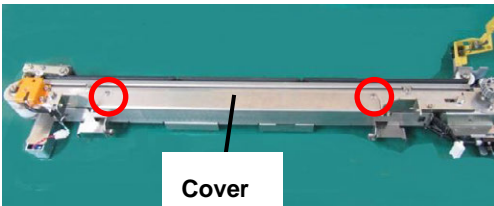

3. Open the feeder cover (lower side) by removing the two screws.

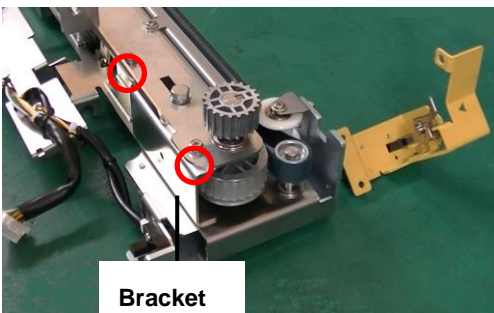

4. Detach the bracket by removing the four screws of the bracket on the both ends.



5. Remove the screws of the solenoid for the belt hold.

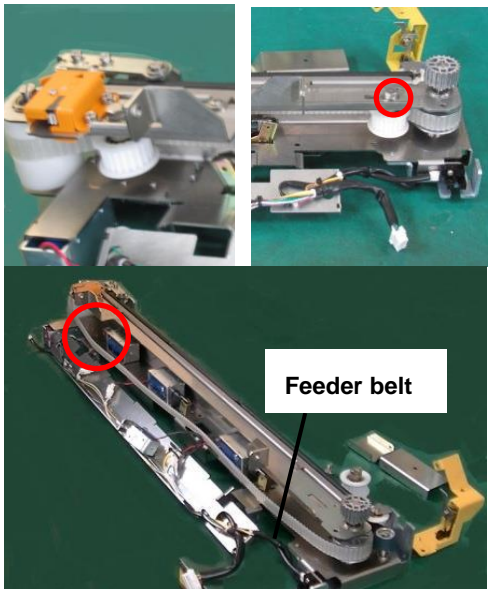

6. Remove the right and left sides of the pulley pressing the feeder belt. Remove first the pulley on tension.
7. Remove the feeder belt by pushing the pawl of the film detector on the left-hand side in an inner direction.

Note:

One side of the feeder belt is cut diagonally to prevent the film from being caught in the belt. Attach a new feeder belt so that the film where is cut diagonally is located in backward position.

Note:

Be sure to perform pinch solenoid adjustment when replacing the feeder belt.
 Confirm that the film pinching part will not be released during film conveyance after performing about 30 times of film feeding operations by use of "27 FILM FEED".

8. To attach the feeder belt, perform the procedure in the reverse order. Adjust the tension of the feeder belt by using the pulley and the tension belt come to the first edge of the long hole.

2.3.3.4 How to replace the clamp

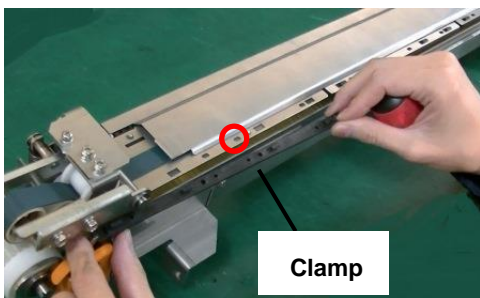

1. Remove the screw, slide and detach the clamp (three locations).

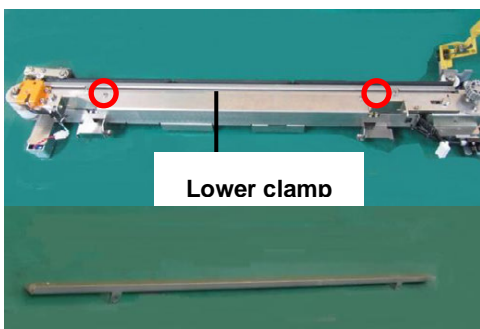

2. Detach the lower clamp by removing the two screws.

2.3.3.5 How to replace the flat belt of feeder

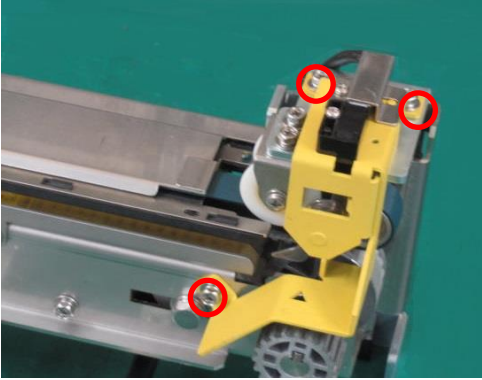

1. Detach the bracket by removing the three screws fixing the bracket.



2. Replace the flat belt by removing the two screws fixing the plate.

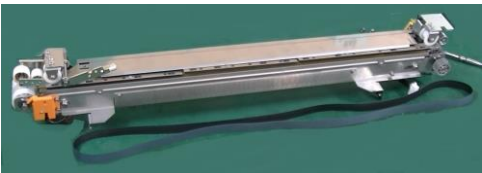

3. To attach the flat belt, perform the procedure in the reverse order.

2.3.3.6 Change of Feeder Flat Belt

In response to an incident report in which the film caught on the flat belt on the rear side and was torn, the end of the flat belt is now processed to make it more slippery, reducing the risk of catching.

Note: There is no change in the front feeder unit flat belt (FLAT BELT:ENDLESS:), but the rotation direction arrows on the flat belt have been removed. Either installation orientation is acceptable.

FLAT BELT:ENDLESS: has been replaced with FLAT BELT:ENDLESS:BLAST.

(Old) 100-002-0179-** → (New) 100-019-0009-**

There is an indication on the end of one side of the FLAT BELT:ENDLESS:BLAST belt. Attach the flat belt so that the end surface side with the indication is on the lift head side.



FLAT BELT:ENDLESS:BLAST installation image

2.3.3.7 Installation of Rail Warp Countermeasure Parts

The "RAIL:LOWER:" and "PLATE A:RAIL:" parts have been changed in order to prevent rail warping when the "RAIL:LOWER:" fixing screws of the feeder unit are inserted. Changing these parts reduces the degree of film slippage caused by rail warping and the generation of film residue during packaging.

Part number	Name	Number required (per unit)
100-135-2868-**	RAIL:LOWER:	2
100-014-5134-**	PLATE A:RAIL:	2
000-079-3018-**	TP SCREW::	10

Installation method

1. Add PLATE A:RAIL: between the screws that secure FRAME:FEEDER: and RAIL:LOWER:. Change the fixing screw to a TP SCREW (M3x6 SUS 2360 with screw lock). (5 red circles below)

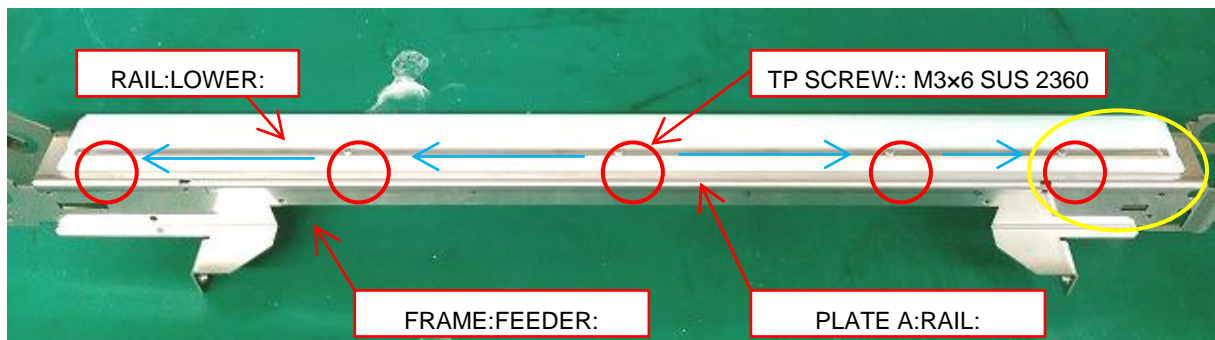

2. To prevent warping, temporarily tighten all fixing screws, then tighten them in order from the center to the outside. (In the order of the blue arrows in the figure above)

Note: The tightening torque is 0.6 Nm (M3 standard tightening torque).

3. The screw fixing position in the yellow circle in the above figure is different depending on when the machine was manufactured. In the case of the same screw fixing position as above, the end of PLATE A:RAIL: cannot be fixed. Therefore, check that the end of the plate does not lift up as shown below. If there is lifting, the plate is warped. Turn the plate over or correct the warp.



2.3.4 In-feed Unit

2.3.4.1 Replacing the in-feed conveyor belt

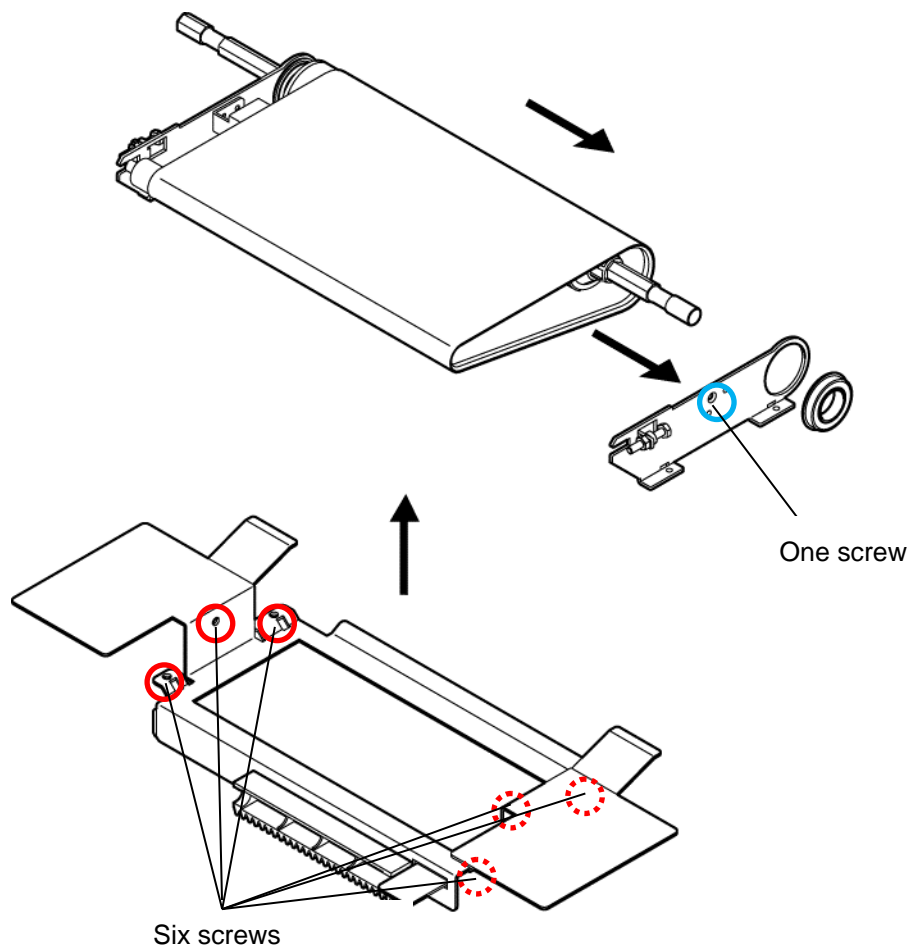

Detach the conveyor from the bracket by removing the six screws.
 Detach the frame by removing one screw after loosening the tension bolt.
 Replace the belt.
 After the replacement, adjust the tension of the belt.
 The tension must be maintained in a level that allows the belt to transfer an object of 6kg
 The following dimension is given as a referential value.

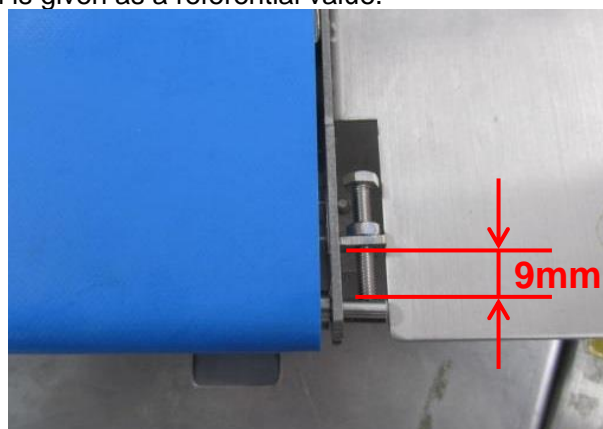

2.3.5 Lift Unit

2.3.5.1 About the assembling of the lift head

1. Use the screws with the following items to mount "GUARD: FILM: LIFT F" to "PLATE B: HEAD: LIFT F". (Refer to Figure1.)

- HEX BOLT: Origin unit 4
- PLAIN WASHER: Origin unit 4
- SPRING WASHER: Origin unit 4

2. Mount "GUARD: FILM: LIFT F" as lift head unit as being centered. The "GUARD: FILM: LIFT F" must be contacted with the lift head unit. (Refer to Figure 1.)

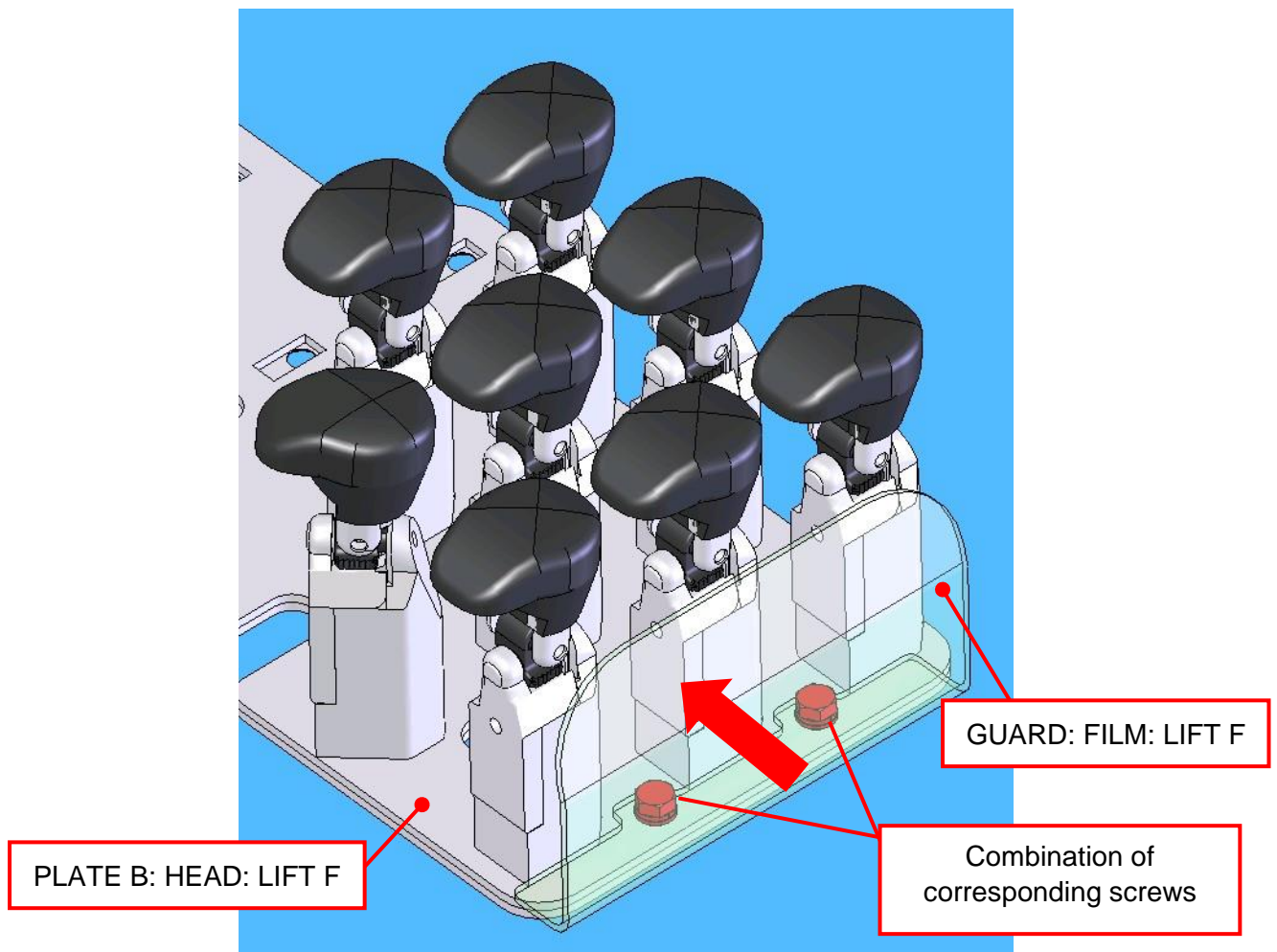
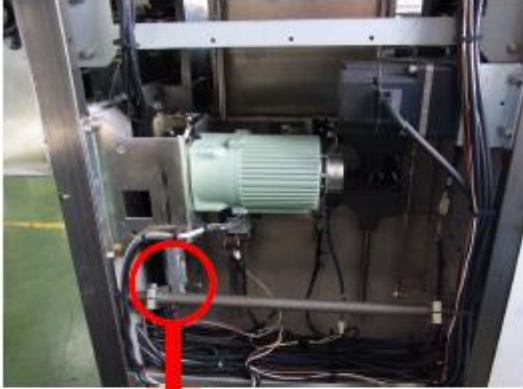

Figure 1: Lift head unit

2.3.5.2 Replacing the lift drive motor

Remove the pin as the yellow arrow shown in the figure below. It is fixed with nut at the opposite side of the pin.

As the pin is pulled and link connection is released, bearing lock is not applied inside the bearing. The bearing lock is applied outside.



2.3.5.3 Mounting the lift drive motor

Mount the motor by placing close to the sensor side.

The elevation stroke cannot be adjusted if the motor is placed to the opposite direction.

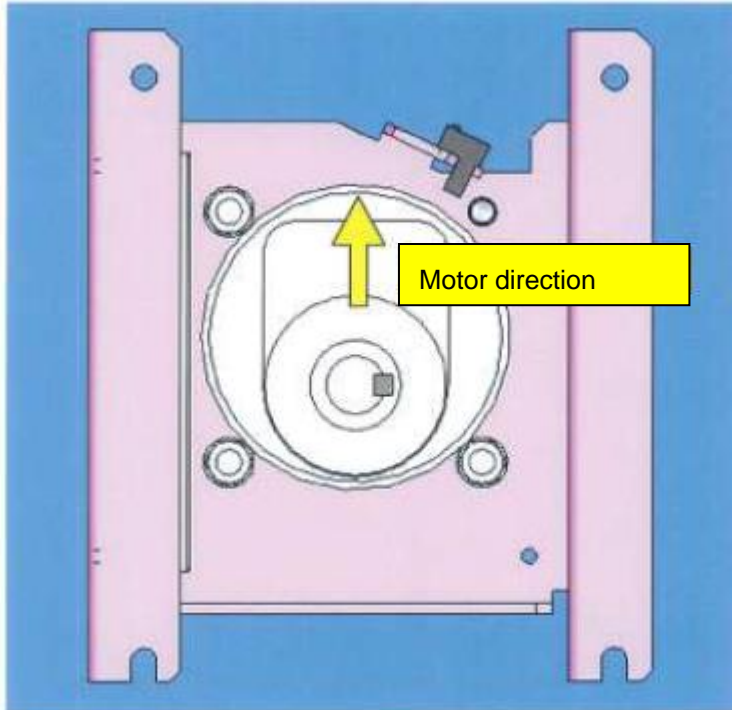

2.3.6 Heater Unit

2.3.6.1 Replacing the heater roller

Replace the heater roller when it is deteriorated or a problem occurs in a heat seal of the film.

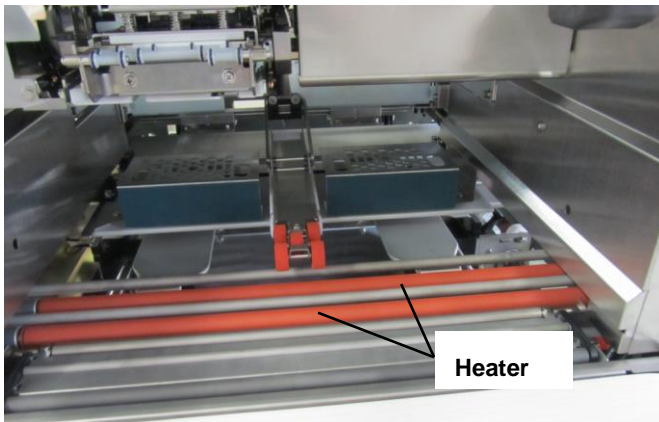

Note:

Before replacing the heater controller, make sure to pull out the power plug from the outlet.

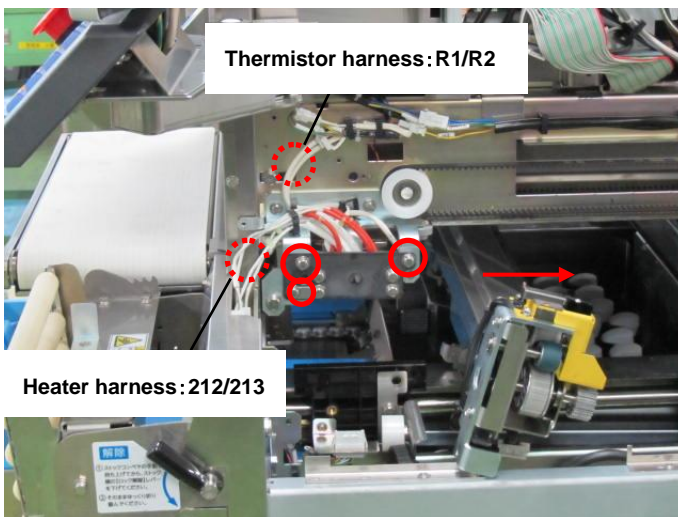

1. Detach the front feeder unit.



REFERENCE

To detach feeder unit, refer to 2.2.2 *Film Feeder Unit*.

2. Remove the harness.

Note:

When attaching harness, use the correct one 212 or 213. Otherwise, it may cause a malfunction.

3. Remove the three screws.

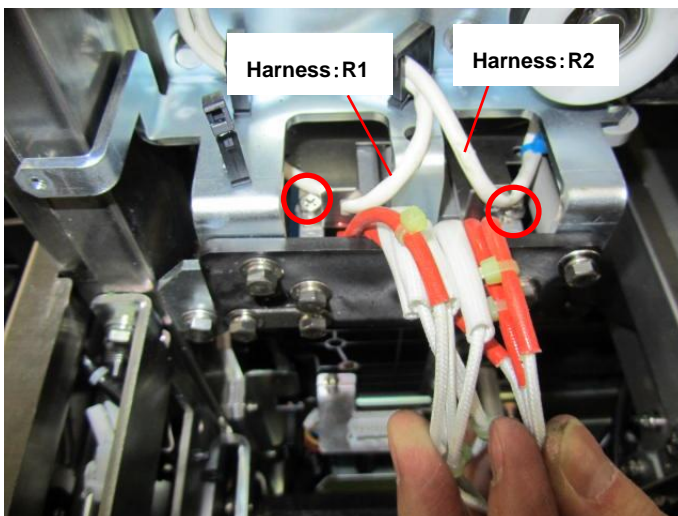

4. Remove the two screws and thermistor.

Note:

When attaching harness, use the correct one R1 or R2. Otherwise, it may cause a malfunction.

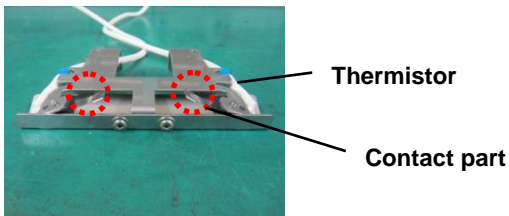

Note:

When attaching and detaching the thermistor, do not bend the contact parts. Make sure that the contact part comes into contact with the heater rollers.

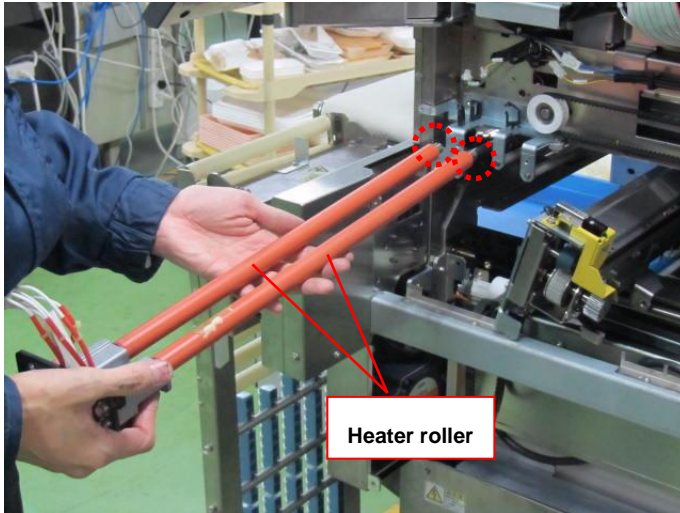

5. Pull out the heater unit and replace the heater rollers.
6. To attach the heater rollers, perform the procedure in the reverse order.



Note:

Two washers are located on the insertion side of the heater unit. Remove the washers before pulling out the heater unit.

2.3.6.2 Attention at the time of the assembling the seal heater unit

Provide restrictions by hanging the harness of the heater roller as shown in the photo below.



2.3.6.3 Fixed position of the heater block

Check the fixed position of the heater block after replacing the heater roller.

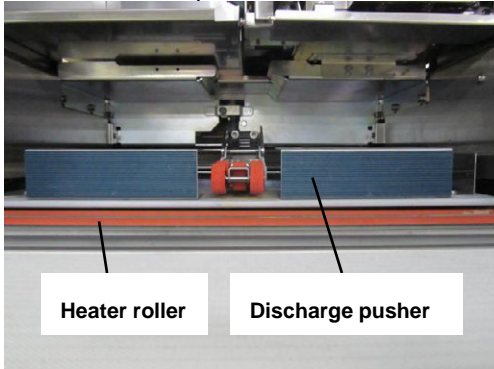

Locate the discharge pusher and heater roller at the same height level. Adjust the fixed position so that the interval between the discharge pusher and the front heater roller is set 1.5 to 2.0 mm, and the interval with the rear heater roller is set 2.5 to 3.0 mm.

The gap between the heater roller and pusher is shown in the figure below.

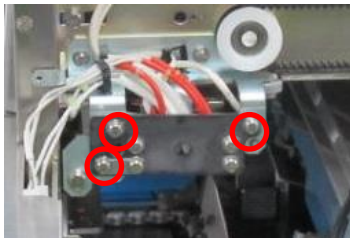
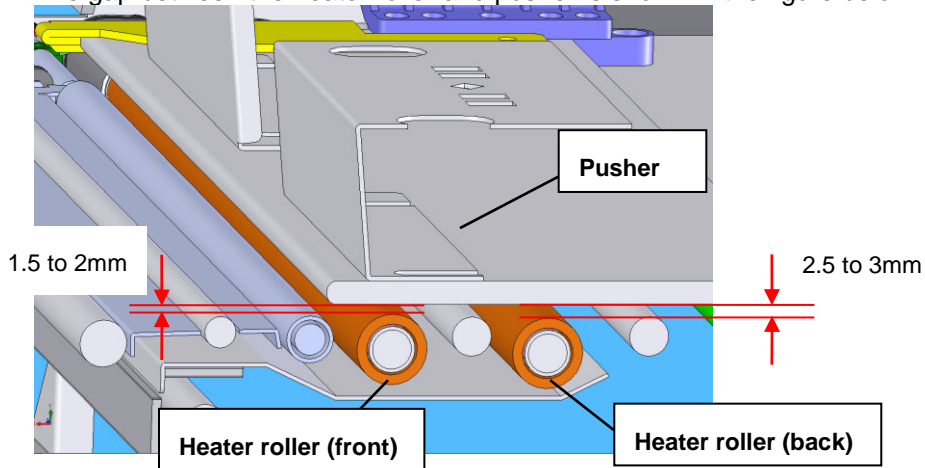

To adjust the fixed position of the heater block, use the three screws on the installation side.



Note:

Make sure that the heater unit does not contact with the side wrapping plates.

2.3.7 Cutter Unit

2.3.7.1 Replacing the cutter

Replace the cutter if there is any problem when cutting films.

To attach the cutter saucer, the cutter unit needs to be adjusted.



1. Remove the film replacement door and left side cover.

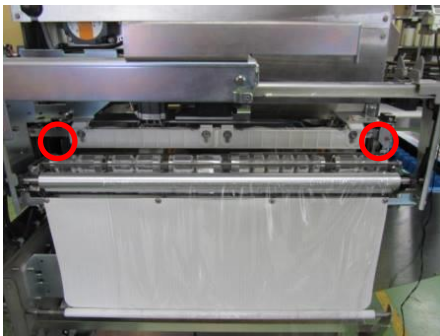

2. Remove the screws on both ends of the cutter unit.



3. Replace the cutter.

Note:

To attach the cutter, attach screw locks to the screws and the installation position of the cutter unit.

2.3.7.2 Attaching and detaching the cutter saucer

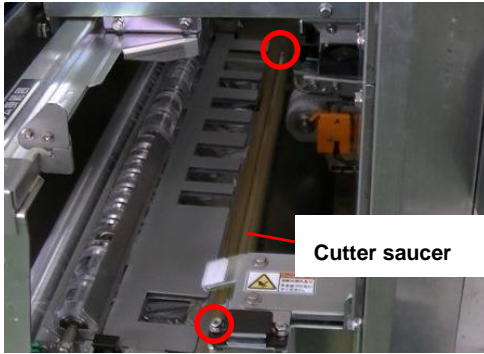

To detach the cutter saucer, remove the screws on both ends of the cutter saucer.

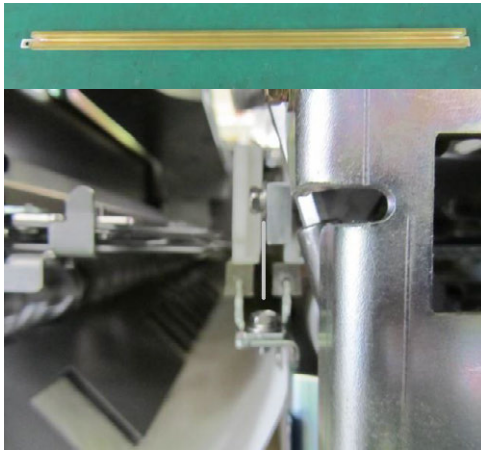

Attaching the cutter saucer to cutter unit

After detaching the cutter saucer, adjust to make the cutter edge to be located in the center of the cutter saucer when the cutter saucer is set on the cutter unit.

2.3.8 Electromagnetic Brake

2.3.8.1 How to remove

- The electromagnetic brake can be detached by removing the bolts with hexagon socket head (3 bolts).
- Note that the lift goes down after the electromagnetic brake is removed from the drive shaft of the DC brushless motor.

2.3.8.2 Precautions on manual elevation of the lift drive unit

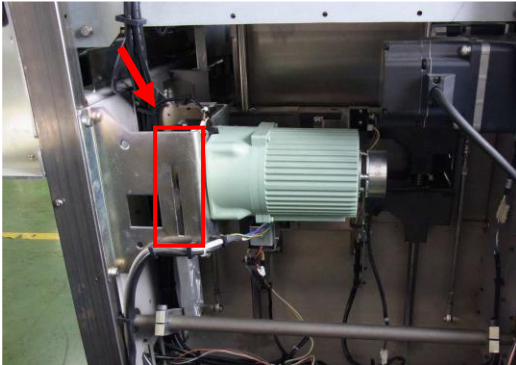

CAUTION

As the lift drive uses a link mechanism; do not turn it to the “no-good side area” when turning it manually.

While it is located in the “no-good side area” and a restore processing is performed, the lift and feeder come in contact with each other, resulting in malfunction.

From the area indicated by the arrow in the picture, check whether it is located in the “no-good side area” or not.

■ Checking for “no-good side area”

It is ok if the detection board mounted on the motor crank is located in forward side.

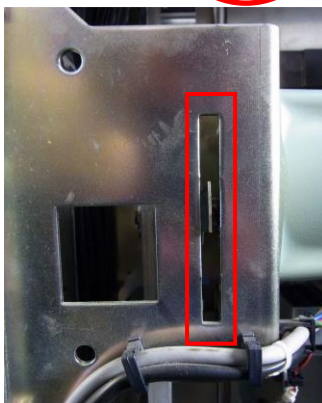
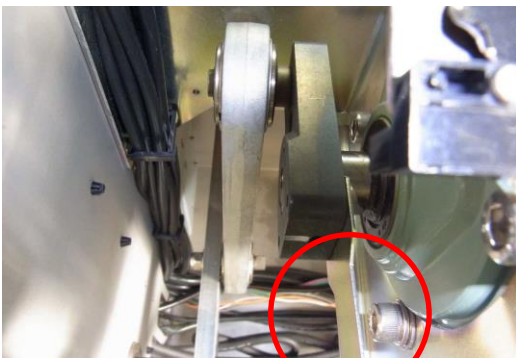

When it is ok, the detection board can be seen from the slit window of the motor bracket.



If the detection board mounted the motor crank is located in the backward side, it is located in the “no-good side area”.

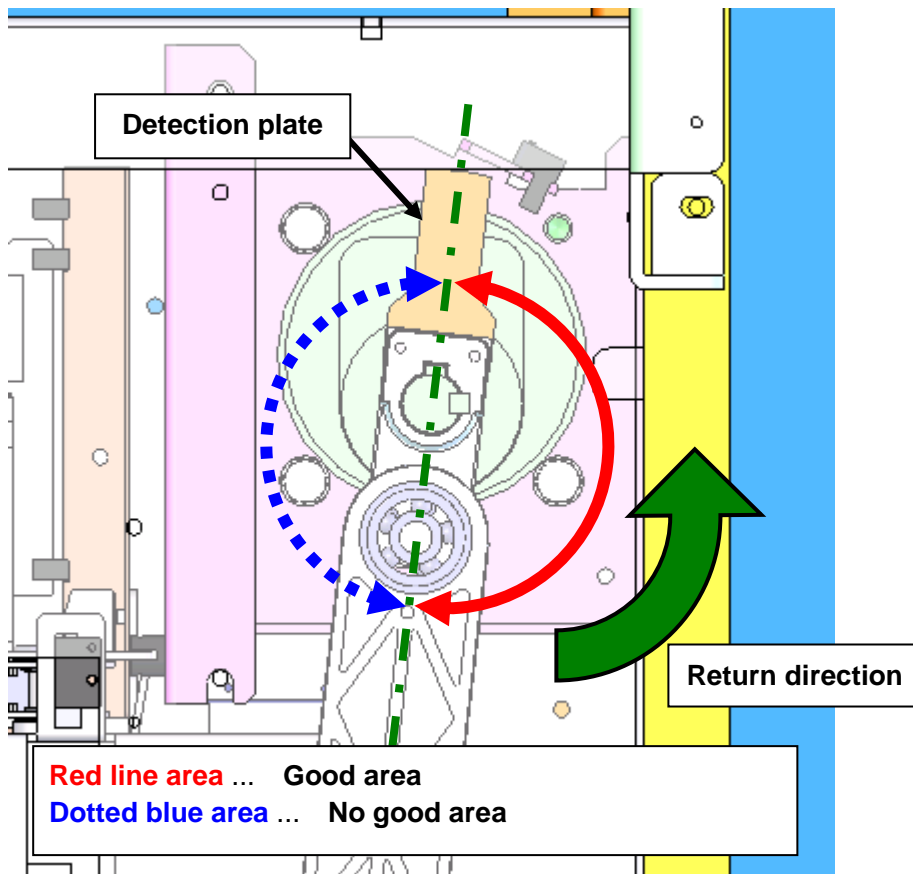

Turn the output axis at the back of the motor with the slotted screwdriver when manually ascending the lift. Before operating manually, be sure to understand the rotation direction and relationship of the elevation shown below.

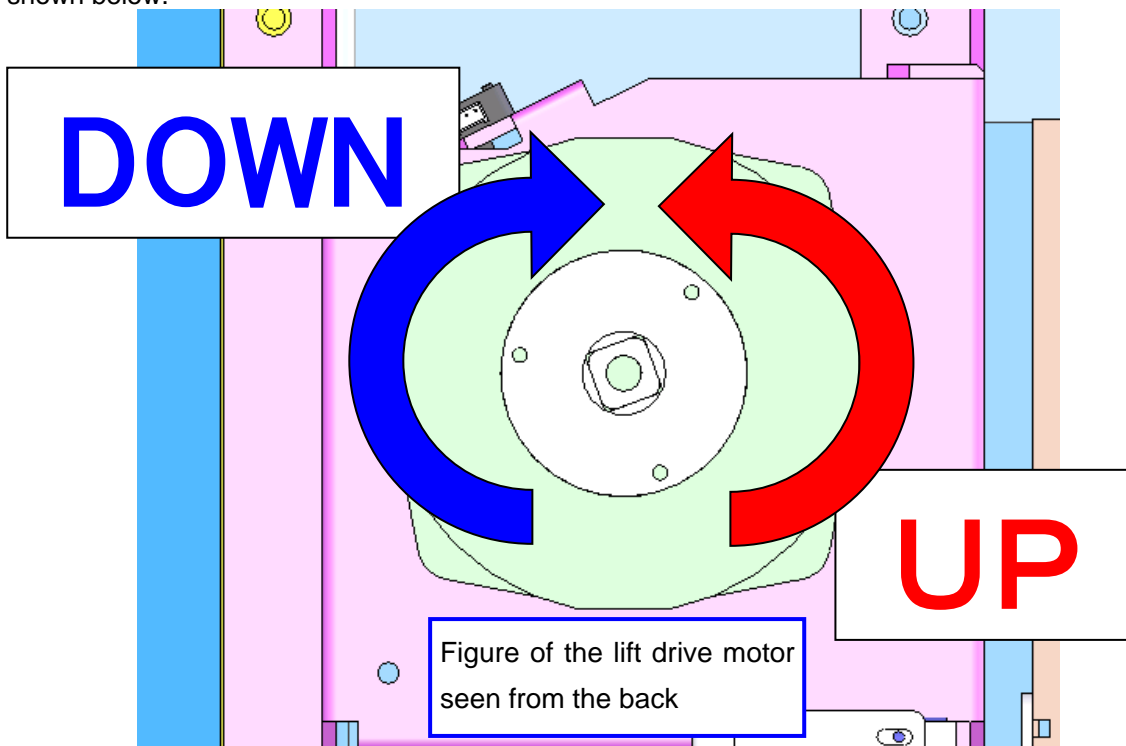

Chapter 3 Electric Components

3.1 Electric Unit Configuration

3.1.1 Overview



Be sure to push the emergency stop switch button when you insert your hand into the machine.



Note that the logic system 24 V DC power is not cut off even if the emergency stop switch button has been pushed.



If the fuse blows, replace it with a designated fuse.

Note:

A precise motor rotation detection sensor is built in the servo motor. Handle the servo motor with extreme care not to give shocks to the motor.

■ Power source

This machine uses two power sources: a single-phase 200 V AC drive system power source that is cut off by pushing an emergency stop switch button, and a 24 V DC constant power supply power source (hereinafter called "logic power source"). The single-phase 200 V AC is supplied to three switching power supplies (for logic power source, wrapper driving, and label applicator driving) via the power switch, built-in breaker, noise filter, and fuse, as well as to P-1105 board, seal heater, and warm air fan heater.

■ Drive system power source

The drive system power source is a power source for movable parts, which is dangerous if it is not cut off when an operator inserts his/her hand in the machine. The drive system power source is cut off by making the electromagnetic contactor operate with the emergency stop switch or four safety switches. The drive system power source supplies power to the single-phase 200 V AC DC brushless motor and stepping motor.

■ Logic power source

The logic power source is generated at the switching power supply for main control on the right side of this machine, and supplied to the logic system circuit, emergency stop switch, and four safety switches.

■ Emergency stop switch / Safety switch

Two contact points are used in the emergency stop switch and four safety switches respectively. One of the contact points of each switch is serially connected to all switches. 24 V DC is supplied to the coil side of the electromagnetic contactor through this serially connected contact point. The other contact point monitors opening and closing of the safety switch with the P-1005 board and displays any errors on the display unit.

■ Electromagnetic contactor

The contact point closes when 24 V DC output from the logic power source is applied to the coil side of the electromagnetic contactor via the emergency stop switch and four safety switches, and 200 V AC is supplied. There are two electromagnetic contactors, and 200 V AC is cut off at the four contact points if 24 V DC is intercepted by opening either the contact point of the emergency stop switch or the contact point of the safety switch. Cut off power supplies are the power source for P-1006 board, power source for P-1105 board, switching power source for wrapper, and switching power source for label applicator.

■ Auxiliary contact point

The electromagnetic contactor has an auxiliary contact point to confirm the switching condition, and the condition is input to the P-1005 board to confirm whether the drive system power source has been intercepted.

■ Motor

As all motors used in this machine have an overload protection circuit, the motors will not burn due to overcurrent.

3.1.2 Back Side of the Machine

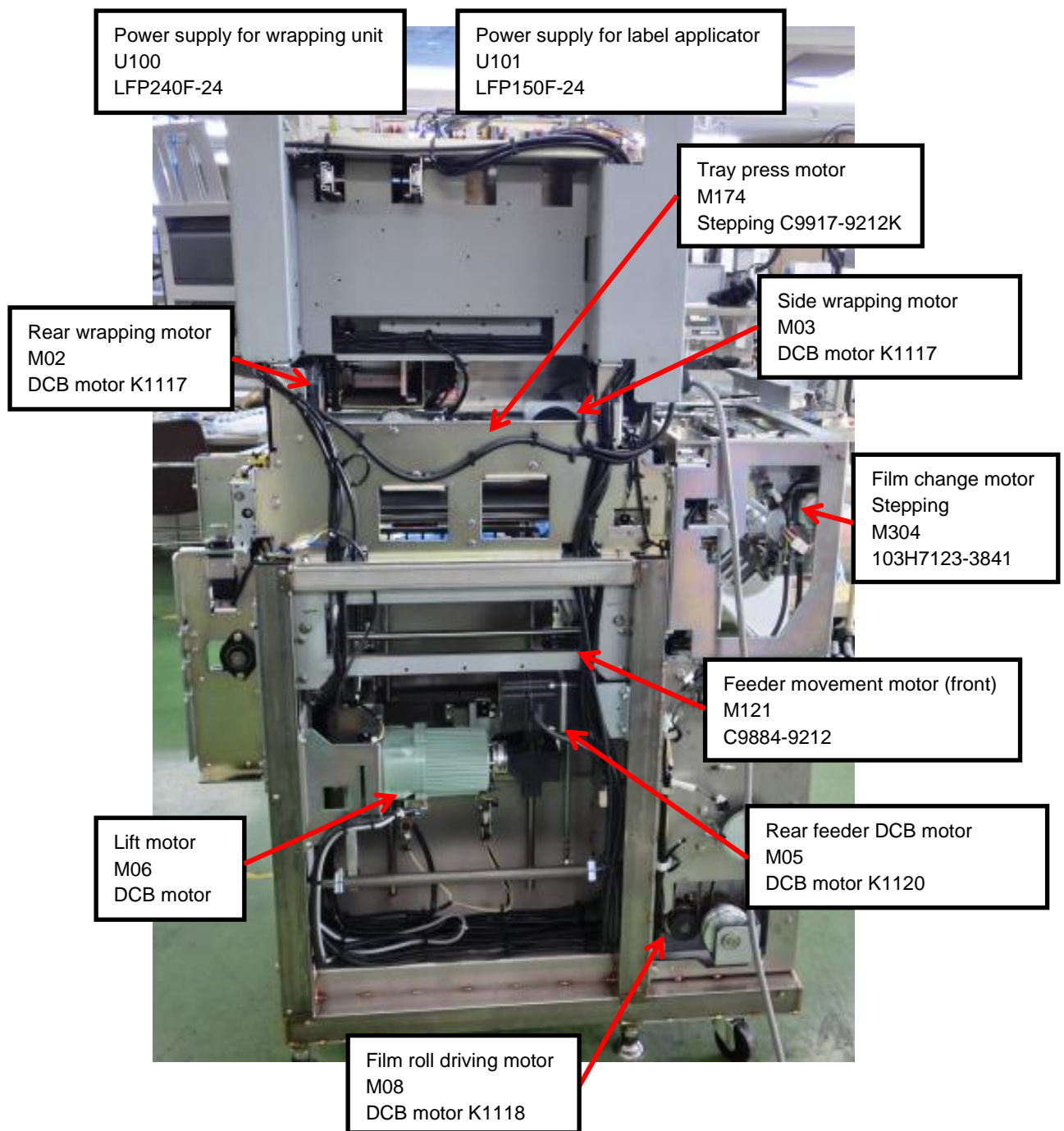

3.1.3 Right Side of the Machine

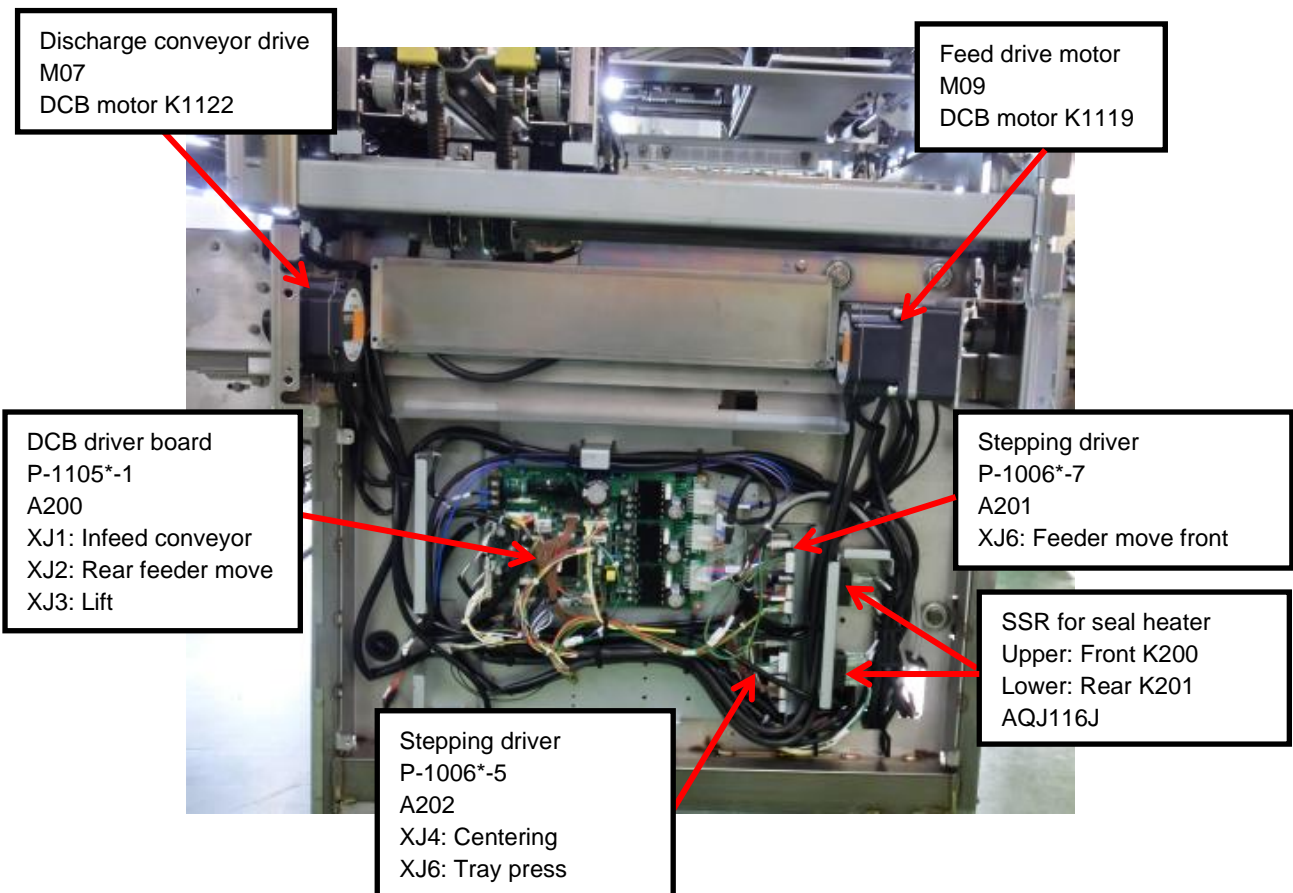
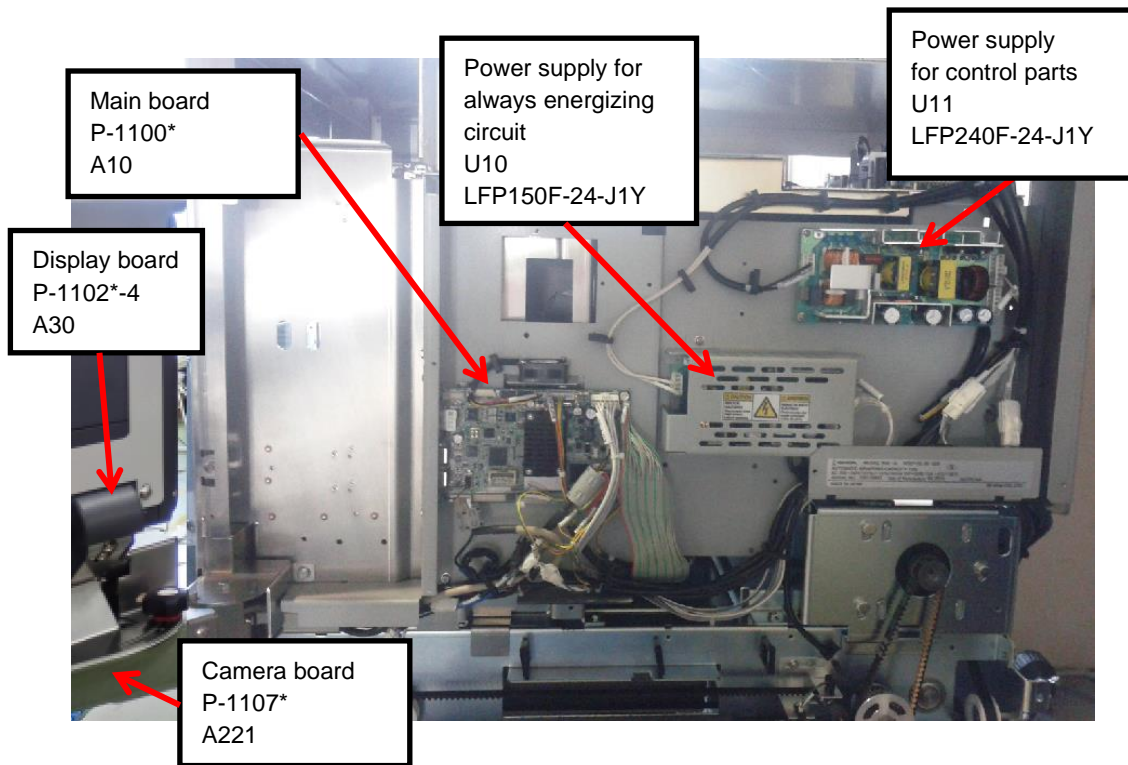

3.1.4 Left Side of the Machine

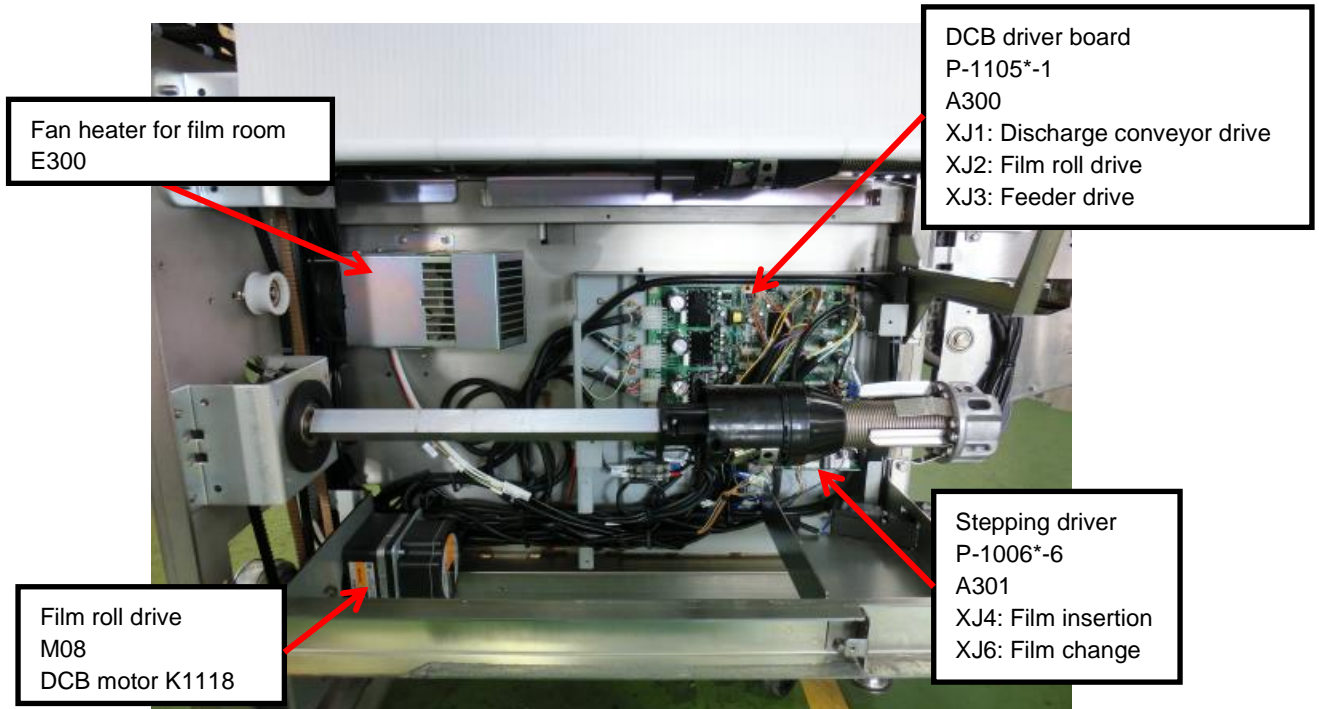
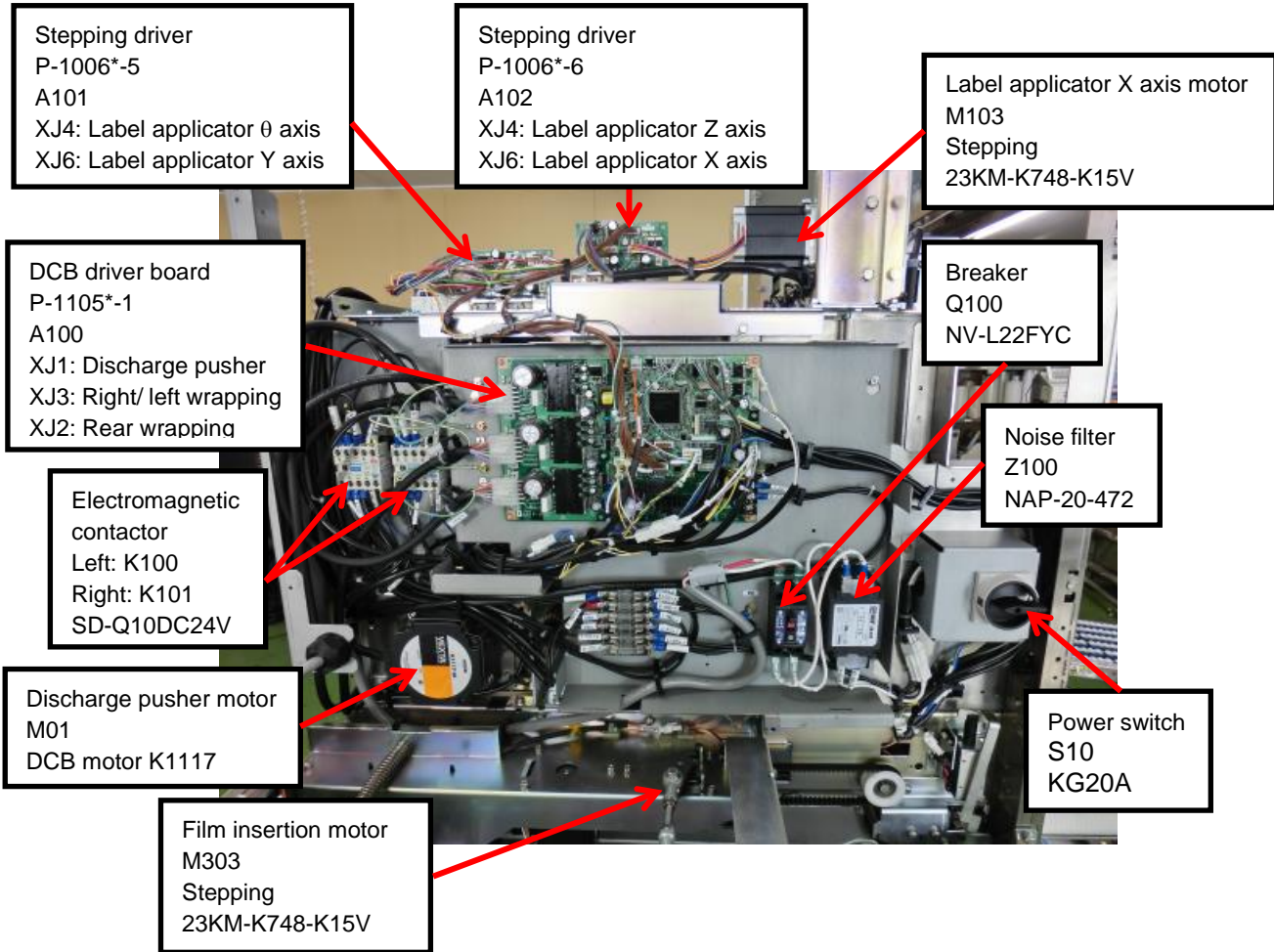

3.2 Main board

3.2.1 Replacing the Main board

P-1100, the main board for AI-series, has applications inside the flash ROM. At shipment, basic software, called boot-software, is installed on the main board for maintenance. Since no application to run exists on the board, it is not operational but only a logo of ISHIDA appears on the screen after power is turned on. Without application, however, the machine can be activated using the application from the USB flash memory, and then software is automatically downloaded from the “Soft” folder in the USB flash memory to the main board.

3.2.1.1 Precaution

When using the USB flash memory for startup, after application has been downloaded to the main board, remove the USB flash memory and restart the machine before you start the work. If directly started from the USB flash memory, the setting may not be properly reflected to the memory of the main body.

Basically, the copy function of “USB > MAIN” only overwrites a file to the flash ROM and does not delete unnecessary files.

If an unnecessary file is accidentally copied, the flash ROM capacity will be consumed, which may cause a copy error of the program file due to capacity shortage. In this case, delete all and copy it again.

If a program of another model is accidentally copied, the machine may not be operational. In this case, restart the machine from the USB flash memory, delete all, and copy the correct program file again.

* To copy the backed up software to the main board, make settings again on the [DOWNLOAD] screen of ADJUST mode after the downloading is automatically completed.

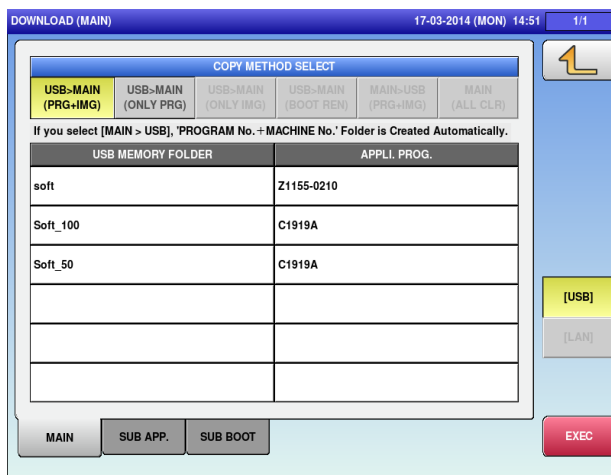

DOWNLOAD (MAIN) screen

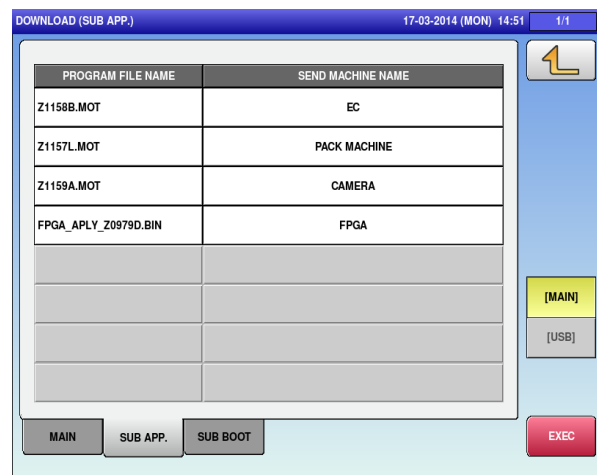

DOWNLOAD (SUB APP.) screen

3.2.1.2 Backing Up Data for Main Board Replacement

- 1 Perform *1.10.2 Backing Up Software on the Main Machine*.
- 2 Display the [FILE Save/Load] screen of SETUP mode.
- 3 Insert the USB flash memory into the USB connector.
- 4 Display the [SCALE > USB] tab.
- 5 Back up the software by selecting “MASTER” in “DATA” and touching the [EXEC] button.

3.2.1.3 Downloading Software after Main board replacement

1. Replace to new main board.
2. Insert the USB flash memory into the USB connector.
3. Apply the power to the main machine.
4. Software starts from the USB flash memory (wait for a while).
5. The [DOWNLOAD] screen of ADJUST mode automatically appears.
6. The program (Soft folder) automatically starts to be downloaded.
7. When a progress status message appears, wait until copying is completed.
8. A confirmation message appears asking to restart the machine, remove the USB flash memory, and restart the machine.

3.3 Sensor

The following Table 1 shows the sensors used for WM-AI.

Table 1

Product No. (As of May 2015)	Product name	Sensor model No.	Sensor type	Description (Connector, harness)	Connector	Unit (See the parts list.)
000-132-6468-**	Photo-interrupter 'transmission type'	KI1480-AAL F	Transmission type	Sensor bottom connector	ZR 3Pin	Heavily used on various units
000-070-5204-**	Photo-interrupter 'transmission type'	KI1285-ID	Transmission type Dark-ON	Sensor side connector Housing: white	PH 3Pin	Heavily used on various units
000-070-5205-**	Photo-interrupter 'transmission type'	KI1286-ID	Transmission type Light-ON	Sensor side connector Housing: black	PH 3Pin	LIFT DRIVE UNIT
000-112-9768-**	Photo-interrupter 'transmission type' light-emitter	KB893-AA12	Emitter	Harness L = 60 mm	SM 2Pin	WRAPPING FRAME UNIT PRINTER FRAME UNIT
000-112-9769-**	Photo-interrupter 'transmission type' light-receiver	KB893-AA22	Receiver Light-ON	Harness L = 60 mm	SM 4Pin	WRAPPING FRAME UNIT PRINTER FRAME UNIT
000-135-0306-**	Sensor AS "centering	APS4-12S-E	Proximity sensor	Harness L = 250 mm	SM 3Pin	FEED UNIT
000-072-2231-**	Sensor AS" upper lift	KR-Q50NWT	Reflection type	Harness L = 140 mm	SM 3Pin	FEEDER MOVE UNIT
100-002-8532-**	Sensor AS"	RS-902S	Proximity sensor	Harness L = 280 mm Insulation tube: black	XA 3Pin	FILM TRANSPORT UNIT (top)
100-002-8533-**	Sensor AS"	RS-902S	Proximity sensor	Harness L = 280 mm Insulation tube: white	XA 2Pin	FILM TRANSPORT UNIT (bottom)
000-112-1169-**	Photo-interrupter 'transmission type' light-emitter	KB1242-ID1 4LF	Emitter Body: gray	Sensor bottom connector	ZR 3Pin	PRINTER UNIT (for peel sensor)
000-112-1170-**	Photo-interrupter 'transmission type' light-receiver	KB1242-ID2 3LF	Receiver Body: black	Sensor bottom connector	ZR 3Pin	PRINTER UNIT (for peel sensor)
100-002-3523-**	Sensor AS"	RS-902S, LN55, PN150	Proximity Emitter + receiver	Harness L = 330 mm	SM 8Pin,2Pin	PRINTER UNIT
000-137-0747-**	Sensor 'Distance'	GP2Y0A41S K0F	Reflection type	Sensor side connector	PH 3Pin	CAMERA UNIT (height detection)
000-135-0220-**	Sensor AS"	ON2153	Reflection type	Harness L = 205 mm	DF 5Pin	APPLICATOR UNIT
000-135-0221-**	Sensor AS"	E3Z-LS61C- SOSHW-P1	Reflection type	Harness L = 340 mm	SM 3Pin	STOCK CONVEYOR UNIT

Make sure that a correct sensor is used for the replacement.

Chapter 4 Setup Mode

4.1 Startup

Turn on the power.

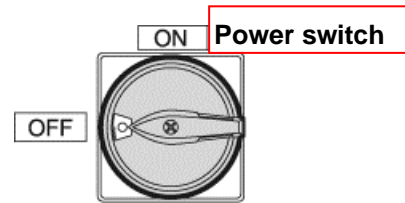

The PREPACK screen in the OPERATE mode appears.

Press  at the upper right side of the screen.



The menu appears in the OPERATE MODE.

Press the [SET UP] button on the screen.

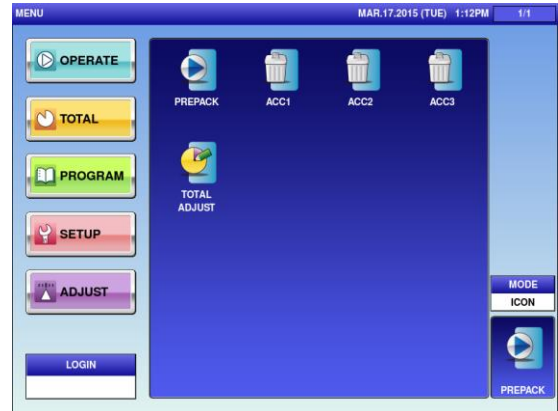

The User Menu screen in the Setup mode appears.

Input the password “495344” using the numerical keys, and press the [LOGIN] button on the screen.

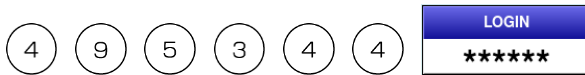

The Maintenance Menu screen appears in the Setup mode.

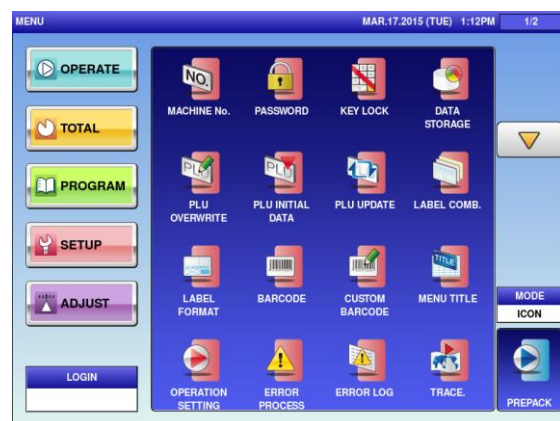

Maintenance Menu screen 1/2

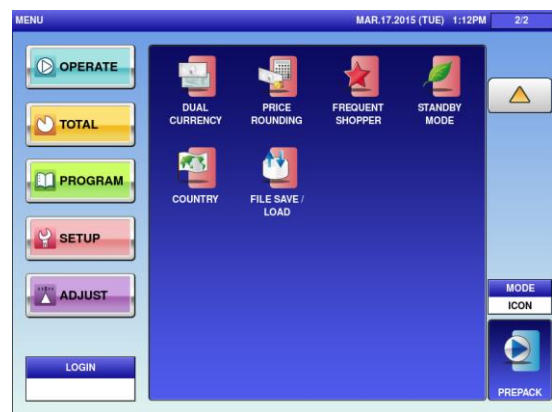

Maintenance Menu screen 2/2



Do not pull out the power supply plug before one minute or less after turning the power switch off

4.2 MACHINE NO. SETTING

4.2.1 MACHINE No. (BASIC)

Menu name	Specification
	Return to Menu. Other tabs also have the same function.
NETWORK No.	Set the machine No. Input range: 0 to 9999
MACHINE SET	Select one of the stand-alone, master or satellite machines. ALONE / MASTER / SAT. This function is enabled only when you log into the service network. The confirmation dialog appears when ALONE, MASTER and SAT. are selected respectively.

4.2.2 MACHINE No. (IP ADDR.)

Menu name	Specification
IP ADDRESS	Set the IP address. Input range: "0.0.0.0" to "255.255.255.255"
SUBNET MASK	Set the subnet mask. Input range: "0.0.0.0" to "255.255.255.255"
DEFAULT GATEWAY	Set the default gateway. Input range: "0.0.0.0" to "255.255.255.255"
DNS SERVER1	Set the IP address of Primary DNS server. Input range: "0.0.0.0" to "255.255.255.255"
DNS SERVER2	Set the IP address of Secondary DNS server. Input range: "0.0.0.0" to "255.255.255.255"
DHCP MODE	Select whether or not to use DHCP.
PING TO PC	Ping the PC. Other tabs also have the same function.
	Enter "."(dot). Used for IP address setting. Other tabs also have the same function.

4.2.3 MACHINE No. (PC COM)

Menu name	Specification
PC IP ADDRESS	Set the PC's IP address. Input range: "0.0.0.0" to "255.255.255.255"
PC PORT No.	Set the PC's port No. Input range: 0 to 65535
COM CHECK PERIOD (SEC)	Set the command check period. Input range: 0 to 9999
COM CHECK TIME OUT (SEC)	Set the command check time-out. Input range: 2 to 5
ERROR LOG SEND	Set whether or not to send the error log.
FIELD NAME ENABLE	Select and set whether or not to add filed name to the CSV title line of the transmission data.
PRESET FUNC. NAME REFER	Select the preset function name reference. COM.DATA / PLU
LAN CONNECT CHECK	Set whether or not to perform LAN connect check.
PROD. TRAN SEND	Set whether or not to perform transmission of Production Transaction. (SLP-5)

4.2.4 MACHINE No. (WiFi)

Menu name	Specification
SECURITY / AUTHENTICATION / ENCRYPTION	Select the method of security/authentication/encryption. NONE / WEP64 / WEP128 / WEP64 Shared Key / WEP128 ShKey / WPA PSK TKIP / WPA PSK CCMP / WPA2 PSK TKIP / WPA2 PSK CCMP
SSID (WIRELESS NETWORK NAME)	Set the SSID. Pressing the button opens the Editor screen to edit.
KEY TYPE	Select the WEP key index. HEX / ASCII / PASSPH
WEP KEY INDEX	Select the WEP key index. 1 / 2 / 3 / 4 This function is enabled only when one of WEP64 / WEP128 / WEP64 Shared Key / WEP128ShKey is selected for security / authentication / encryption.
WEP64 KEY	Set the WEP64 Key. Up to 5 bytes This function is enabled only when one of WEP64 / WEP128 / WEP64 Shared Key / WEP128ShKey is selected for security / authentication / encryption.

4.2.5 MACHINE No. (GLOBAL SV.)

Menu name	Specification
GLOBAL SERVICE ENABLE	Select and set whether or not to use the cloud function (Global Service).
The following parameters are valid only when the GLOBAL SERVICE ENABLE setting is set to [ENABLE] (grayed out when set to [DISABLE])	
GLOBAL SERVICE URL	Set the URL of Cloud server (only when the function is valid). Press the button to open the Editor screen to edit.
PROXY SERVER URL	Set the URL of Proxy server (only when the function is valid). Press the button to open the Editor screen to edit.
PING TO SERVICE	Send PING to the set cloud server (When the cloud function is not in use, the option is grayed out).

4.2.6 MACHINE No. (SYNC.)

The screenshot shows a web-based configuration interface for a device. The title bar reads 'MACHINE No. (SYNC.)' and the top right corner shows the date and time '06-03-2014 (THU) 9:20'. The main content area is divided into sections. At the top, there is a blue header 'CLOCK SYNC. WITH NTP SERVER' with two buttons: 'DISABLE' (grayed out) and 'ENABLE' (yellow). Below this is a text input field labeled 'NTP SERVER URL' containing the text 'ntp.nict.jp'. To the right of the main area is a vertical sidebar with a yellow arrow icon at the top and a red 'PING' button. At the bottom of the screen, there is a horizontal menu with several tabs: 'BASIC', 'IP ADDR.', 'PC COM', 'WiFi', 'GLOBAL SV.', and 'SYNC.'. The 'SYNC.' tab is currently selected.

Menu name	Specification
CLOCK SYNC. WITH NTP SERVER	Select and set whether or not to use the clock synchronization.
NTP SERVER URL	Set the URL of NTP server. When this function is not in use, the option is grayed out. Press the button to open the Editor screen to edit.

4.2.7 MACHINE No. (OUTSIDE PRINTER)

MACHINE No. (OUTSIDE PRINTER) MAR.28.2014 (FRI) 2:36PM

No.	CONNECT		IP ADDRESS
1	USB	LAN	0.0.0.0

PING

BASIC IP ADDR. PC COM WiFi GLOBAL SV. OUTSIDE PRN SYNC.

Menu name	Specification
CONNECT	Select and set the connection method for external printer. USB / LAN
IP ADDRESS	Set the IP address of the printer when the LAN connection is selected. When the USB is selected, this option is grayed out.

4.3 PASSWORD

4.3.1 PASSWORD (OPERATE)

PASSWORD (OPERATE) 06-03-2014 (THU) 10:50 1/1

PASSWORD 000000

MENU NAME	SELECT	
(1001) SALES	USE	NO USE
(1003) ACC1	USE	NO USE
(1004) ACC2	USE	NO USE
(1005) ACC3	USE	NO USE
(1002) TOTAL ADJUST	USE	NO USE
	USE	NO USE
	USE	NO USE

OPERATE TOTAL PROGRAM SETUP ADJUST

Menu name	Specification
PASSWORD	Set the password in six digits. Logging in by this password will release the menu operation prohibited status.
MENU NAME	Display the menu name. Both USE and NO USE for SALES are grayed out because SALES cannot be locked with the password.
SELECT	Select whether or not to lock with the password. USE: Locked NO USE: Not locked

(All tabs have the same operations so their explanations are omitted here.)

4.4 KEY LOCK

4.4.1 KEY LOCK (DISPLAY KEY)

KEY LOCK (DISPLAY KEY) 06-03-2014 (THU) 11:13 1/1

PASSWORD 000000

KEY NAME	KEY LOCK	
PLU NAME AREA	YES	NO
TARE	YES	NO
WEIGHT/PRICE	YES	NO
PCS	YES	NO
	YES	NO
	YES	NO
	YES	NO

DISPLAY KEY FUNCTION KEY STROKE KEY

Menu name	Specification
PASSWORD	Set the password in six digits. Normally in the PRODUCTION screen, enter this password and press KEY LOCK FUNCTION to release the input prohibited status.
KEY NAME	Display the measurement menu on the normal mode screen.
KEY LOCK	Select whether or not to set a key lock. YES: The key lock is set. NO: The key lock is not set.

4.4.2 KEY LOCK (FUNCTION KEY)

KEY LOCK (FUNCTION KEY) 06-03-2014 (THU) 11:13 1/19

PASSWORD 000000

KEY NAME	KEY LOCK	
	YES	NO
PLU	YES	NO
TARE	YES	NO
F/P	YES	NO
MULTI	YES	NO
SPECIAL	YES	NO
-€	YES	NO
-%	YES	NO

DISPLAY KEY FUNCTION KEY STROKE KEY

Menu name	Specification
PASSWORD	Set the password in six digits. Normally in the PRODUCTION screen, enter this password and press KEY LOCK FUNCTION to release the input prohibited status.
KEY NAME	Display the function key name.
KEY LOCK	Select whether or not to set a key lock. YES: The key lock is set. NO: The key lock is not set.

4.4.3 KEY LOCK (STROKE KEY)

KEY LOCK (STROKE KEY) 06-03-2014 (THU) 12:00 1/1

PASSWORD 000000

KEY NAME	KEY LOCK	
TARE	YES	NO
UNIT PRICE	YES	NO
FIXED PRICE	YES	NO
PRESET	YES	NO
	YES	NO
	YES	NO
	YES	NO

DISPLAY KEY FUNCTION KEY STROKE KEY

Menu name	Specification
PASSWORD	Set the password in six digits. Normally in the PRODUCTION screen, enter this password and press KEY LOCK FUNCTION to release the input prohibited status.
KEY NAME	Display the stroke key name.
KEY LOCK	Select whether or not to set a key lock. YES: The key lock is set. NO: The key lock is not set.

4.5 DATA STORAGE

4.5.1 DATA STORAGE (TOTAL ADD.)

DATA STORAGE (TOTAL ADD.) 06-03-2014 (THU) 12:04 1/2

MENU NAME	SELECT	
DAILY TOTAL	NON ADD	ADD
WEEKLY TOTAL	NON ADD	ADD
CUMULATIVE TOTAL	NON ADD	ADD
TIME TOTAL	NON ADD	ADD
OPERATOR TOTAL	NON ADD	ADD
ACC1 TOTAL	NON ADD	ADD
ACC2 TOTAL	NON ADD	ADD
ACC3 TOTAL	NON ADD	ADD

TOTAL ADD. TOTAL PROC. TRANSACTION STORAGE

Menu name	Specification
MENU NAME	Display the menu name.
SELECT	Select whether or not to add. NON ADD / ADD
The TOTAL PROC. / TRANSACTION / STORAGE tabs are displayed only when you access above menus after logging in with the service password.	

4.5.2 DATA STORAGE (TOTAL PROC.)

DATA STORAGE (TOTAL PROC.) 06-03-2014 (THU) 12:04

FIX PRICE ITEM ADD WEIGHT

FIX WEIGHT	REAL WEIGHT
------------	-------------

WRAP MODE WEIGHT ADD

NON ADD	ADD
---------	-----

TOTAL ADD.

TOTAL PROC.

TRANSACTION

STORAGE

Menu name	Specification
FIX PRICE ITEM ADD WEIGHT	Select the addition weight of fixed-price items. FIX WEIGHT / REAL WEIGHT
WRAP MODE WEIGHT ADD	Select and set whether or not to perform Weight Add in the production in the WRAP mode.

4.5.3 DATA STORAGE (TRANSACTION)

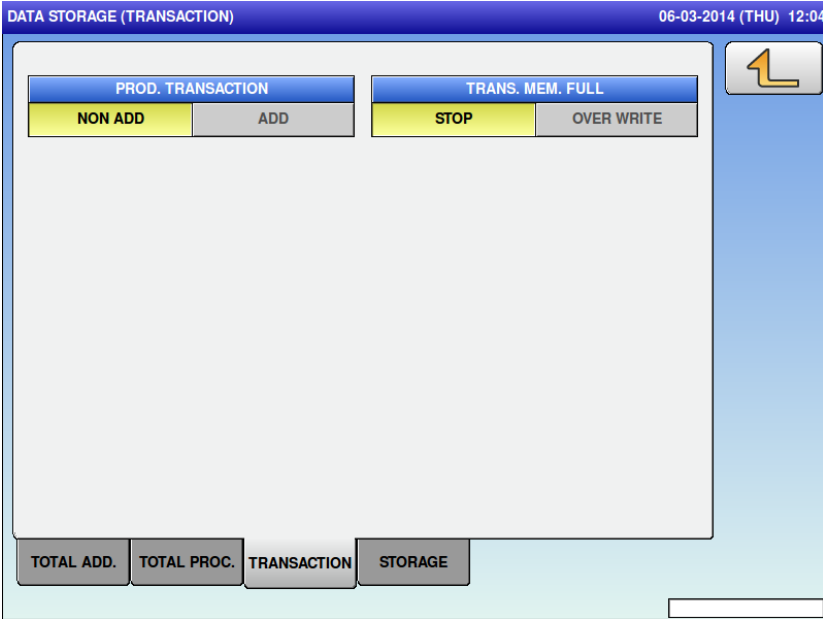

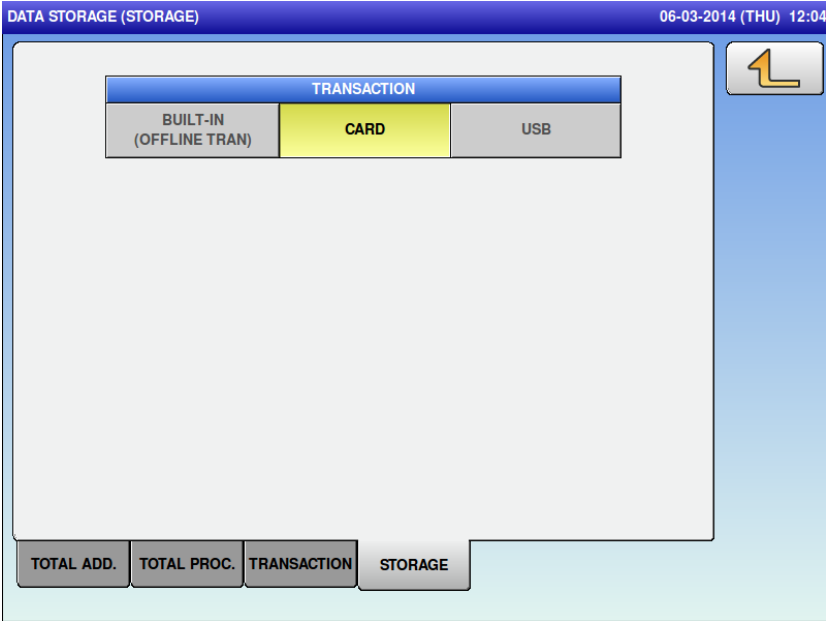

Menu name	Specification
PROD. TRANSACTION	Select whether or not to add the product transaction. NON ADD / ADD
TRANS. MEM. FULL	Select between stopping or overwriting the transaction addition at full memory condition. STOP / OVERWRITE

4.5.4 DATA STORAGE (STORAGE)



Menu name	Specification
TRANSACTION	Select where to save the transaction. BUILT-IN / CARD / USB

4.6 PLU OVERWRITE

PLU MASTER LIST		SELECT	
UNIT PRICE:FIX PRICE	YES	NO	 
MARKDOWN MODE:M/D AMOUNT	YES	NO	
UNIT TYPE:QTY	YES	NO	
FIXED WEIGHT	YES	NO	
PACK DATE/TIME	YES	NO	
SELL BY DATE/TIME	YES	NO	
TARE	YES	NO	
EXTRA MSG.1	YES	NO	
INGREDIENT	YES	NO	
EXTRA MSG.3	YES	NO	

Menu name	Specification
PLU MASTER LIST	Display the PLU master item.
SELECT	Select whether or not to automatically update the PLU master item. YES / NO

4.7 PLU INITIAL DATA

4.7.1 PLU INITIAL DATA (SALE1)

PLU INITIAL DATA (SALE1) MAR.20.2014 (THU) 9:48AM

SALES MODE
UNIT PRICE
OPEN PRICE

< 0:WEIGHT >
0.00
< 0:YES >

FIXED WGT
TARE

0.000
0.000

MARKDOWN MODE
M/D AMOUNT
2nd TARE

< 0:NORMAL >
0.00
0.000

UNIT TYPE
QTY
% TARE

0:NO PRN
0
0.0

LOWER WGT
UPPER WGT
FORCED TARE

0.000
0.000
YES NO

SALE1
MSG.
IMAGE
PRINT
DATE
CODE
WRAP

Menu name	Specification
	Used to enter fractions. (Valid only when entering the fixed No. of items.) Other tabs also have the same function.
(Each item)	Set the initial value to newly create the PLU master.

4.7.2 PLU INITIAL DATA (MSG.)

PLU INITIAL DATA (MSG.) MAR.20.2014 (THU) 9:49AM 1/3

NUTRITION	0	NONE
EXTRA MSG.1	0	NONE
INGREDIENT	0	NONE
EXTRA MSG.3	0	NONE
COUPON MSG.	0	NONE
POP MSG.	0	NONE
COOKING TIME	0	NONE
FREE MSG.1	0	NONE

Menu name	Specification
(Each item)	Set the initial value to newly create the PLU master.

4.7.3 PLU INITIAL DATA (IMAGE)

PLU INITIAL DATA (IMAGE) MAR.20.2014 (THU) 9:49AM

IMAGE 1 0

IMAGE 2 0

IMAGE 3 0

SH. IMAGE 0

SAFE HANDLING IMAGE

NO PRINT

PRINT

SALE1

MSG.

IMAGE

PRINT

DATE

CODE

WRAP

Menu name	Specification
(Each item)	Set the initial value to newly create the PLU master. Pressing an image number item displays the image list.

4.7.4 PLU INITIAL DATA (PRINT)

PLU INITIAL DATA (PRINT) 05-04-2014 (SAT) 13:42



1st LABEL ATTACH TYPE	2nd LABEL TYPE	1st LABEL BAR PRINT
< 0:REFER >	< 1:NO >	< 1:YES >
1st LABEL FORMAT No.	2nd LABEL FORMAT No.	
0	0	
PRINT MODE	1st LABEL PRINT	2nd LABEL PRINT
< 1:YES >	< 1:YES >	< 1:YES >
SUB LABEL PRINT	EYECATCH LABEL PRINT	
< 1:YES >	< 1:YES >	

SALE1 MSG. IMAGE PRINT DATE CODE WRAP

Menu name	Specification
(Each item)	Set the initial value to newly create the PLU master.

4.7.5 PLU INITIAL DATA (DATE)

PLU INITIAL DATA (DATE) MAR.20.2014 (THU) 9:49AM



PACK DATE PRINT <input checked="" type="checkbox"/> YES <input type="checkbox"/> NO	PACK TIME PRINT <input type="checkbox"/> < 0:NO PRINT >	PACK TIME DATA <input type="text"/>
SB DATE PRINT <input checked="" type="checkbox"/> YES <input type="checkbox"/> NO	SB TIME PRINT <input type="checkbox"/> < 0:NO PRINT >	SB TIME DATA <input type="text" value="0 MIN.(S) AFTER"/>
SHELF LIFE(days) <input type="text" value="NEXT DAY(1 day)"/>	USE BY DATE PRINT <input type="checkbox"/> YES <input checked="" type="checkbox"/> NO	UB DATE DATA <input type="text"/>
DATE CAL <input type="checkbox"/> YES <input checked="" type="checkbox"/> NO		

SALE1
MSG.
IMAGE
PRINT
DATE
CODE
WRAP

Menu name	Specification
(Each item)	Set the initial value to newly create the PLU master.

4.7.6 PLU INITIAL DATA (CODE)

PLU INITIAL DATA (CODE) MAR.20.2014 (THU) 9:49AM

ITEMCODE 00000000	REG. CODE 0	POS FLAG 02
BARCODE 00000000000000	POS REFERENCE < 0:REFER >	BARCODE TYPE 0:REFER
POS FORMAT (WGT) REFER	TRACE ENABLE YES NO	
DEPARTMENT 0	GROUP 00	

SALE1 MSG. IMAGE PRINT DATE CODE WRAP

Menu name	Specification
(Each item)	Set the initial value to newly create the PLU master.

4.7.7 PLU INITIAL DATA (WRAP)

PLU INITIAL DATA (WRAP) APR.24.2015 (FRI) 6:07PM



TRAY No.

0

WRAP MODE

< 1:WRAP+LABEL >

VOLUME

< 0:NONE >

PASTE MODE

< 1:AUTO >

DIRECTION

< 0:NORM. PASTE >

TRAY VOL. DETECT.

< 1:AUTO >

FEED SPEED

< 0:TRAY REF. >

WRAP SPEED

< 0:TRAY REF. >

TRAY AUTO DETECT.

< 2:YES >

TRAY CENTERING

< 0:YES >

TRAY OUTFEED STOP

< 0:TRAY REF. >

TRAY HOLD

< 0:TRAY REF. >

SALE1

MSG.

IMAGE

PRINT

DATE

CODE

WRAP

Menu name	Specification
(Each item)	Set the initial value to newly create the PLU master.

4.8 PLU UPDATE

CHANGE RANGE	
START No.	END No.
1	99999999

UNIT PRICE No.					CONDITION	
1	2	3	4	5	NO	YES

No.	LIST NAME	REPLACE CONDITION	CHANGE CONTENTS
1	ITEM CODE		
2	PACK DATE PRINT		
3	PACK TIME PRINT		
4	PACK TIME DATA		
5	SB DATE PRINT		
6	SB TIME PRINT		

Buttons: BATCH DELETE, EXEC

Menu name	Specification
START No.	Set the start No. of the batch change range. Input range: 1 to 99999999
END No.	Set the end No. of the batch change range. Input range: 1 to 99999999
UNIT PRICE No.	Set the unit price No. for the batch change. Touch the button to change the selection.
CONDITION	Select whether or not to specify the replacement condition for the batch change. NO / YES
LIST NAME	Display the item for the batch change. Touch the button to change the selection.
REPLACE CONDITION	Specify the replacement condition. This function is enabled when [YES] is selected in [CONDITION].
CHANGE CONTENTS	Specify the replacement contents.
BATCH DELETE	Cancel all selections.
EXEC	Execute the batch change. The ALL REUPDATE CHECK dialog appears to ask whether to execute the batch change.

4.9 LABEL COMB

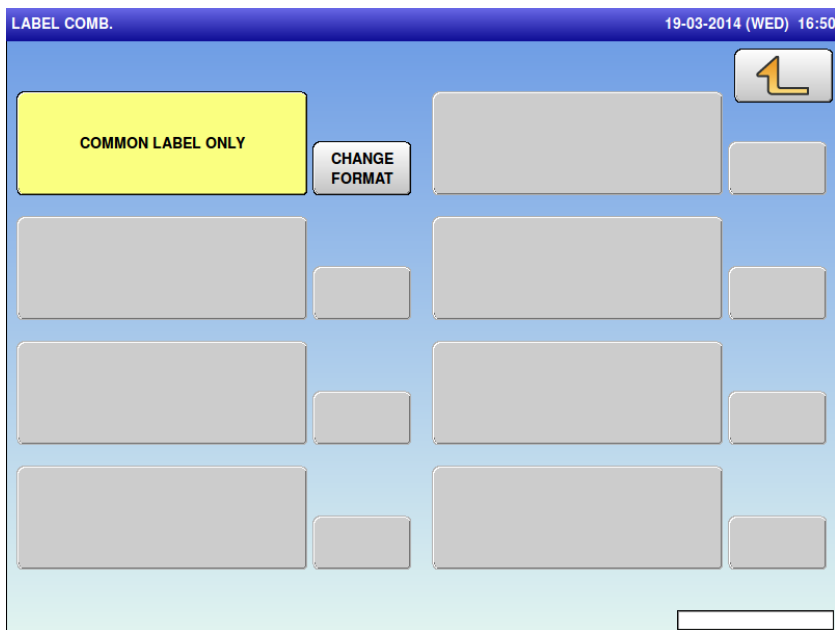

Menu name	Specification
CHANGE FORMAT	Open the LABEL COMB. (BASIC) screen.
COMMON LABEL ONLY	Set the print pattern to [COMMON LABEL ONLY].

4.9.2 LABEL COMB. (LABEL)

LABEL COMB.(LABEL) 19-03-2014 (WED) 18:13

PRINTER PRN 1	CASSETTE No. 1	LABEL No. 01	 FEED PRINT MODIFY FORMAT DETAIL
LABEL TYPE 1:130LA-1	PRINT DENSITY 5	RED DENSITY 5	
PRINT DIRECTION STAND. REVERSE	LABEL GAP 2.2mm		
SENSOR TYPE 2:MARK	PRINT SPEED 100mm/s	BACK FEED NO YES	
SENSOR DISTANCE 51.0mm	FEED LENGTH 7.3mm	PRE-STOP POS. 3.8mm	
CONFIRM TO PRINT		FORMAT INFO	
FMT No. 001	PLU No. 00000000	WIDTH 60.0 mm	
		LENGTH 44.0 mm	
BASIC LABEL UPPER FIX			

Menu name	Specification
PRINTER	Select or set the printer by entering the number. Only the printer connected can be set.
LABEL No.	Set the label master No. Input range: 1 to 99 If there is no set master, the [LABEL SETTING MASTER IS NOT PROGRAMMED] dialog appears to ask whether to create a new master.
LABEL TYPE	Select the label type. 0: RECEIPT / 1: 130LA-1 / 3: 150LA-1
PRINT DENSITY	Set the print density. Input range: 0 to 9
PRINT DIRECTION	Set the print direction. STAND. / REVERSE
LABEL GAP	Set the label gap. Input range: 0 to 99.9
SENSOR TYPE	Set the sensor type. 0: NO USE / 1: LABEL / 2: MARK
PRINT SPEED	Set the print speed. Input range: 60 to 130

Menu name	Specification
BACK FEED	Select whether or not to set the back feed. NO/YES
SENSOR DISTANCE	Set the label sensor distance. Input range: 0 to 99.9
FEED LENGTH	Set the feed length. Input range: 0 to 99.9
PRE-STOP POS.	When printing the second line, feeding of the printed label is stopped and resumed again immediately when the pasting machine absorbs the label. This option sets the label feeding distance to the position from the edge of head front at the temporal stop of the label feeding. Input range: 0 to 99.9
(CONFIRM TO PRINT) FMT No.	Set the test print label format. Input range: 1 to 999
(CONFIRM TO PRINT) PLU No.	Set PLU No. to use for test printing. Input range: 00000000 to 99999999
(FORMAT INFO) WIDTH	Display the format width for the test print.
(FORMAT INFO) LENGTH	Display the format length for the test print.
CASSETTE No.	Display the cassette No. Only for display

4.9.3 LABEL COMB. (UPPER FIX)

The screenshot shows a software interface for setting up label printing. The title bar reads 'LABEL COMB.(UPPER FIX)' and the system clock shows '19-03-2014 (WED) 18:49'. The main display area has three data fields: 'PRINTER' set to 'PRINTER 1', 'FORMAT No.' set to '52', and 'CASSETTE No.' which is currently blank. On the right side, there are four buttons: 'FEED', 'PRINT', 'MODIFY FORMAT' (which is highlighted in green), and 'DETAIL'. At the bottom of the screen, there are three tabs: 'BASIC', 'LABEL', and 'UPPER FIX', with 'UPPER FIX' being the active tab.

Menu name	Specification
PRINTER	When the paste type is set to FIXED, display the printer to print the label. Move to the PRINTER SELECT screen.
FORMAT No.	When the paste type is set to FIXED, set the format to be used in the label printing. Input range: 1 to 999
CASSETTE No.	When the paste type is set to FIXED, set the cassette to use for label printing. Only printers including cassettes can be set.
MODIFY FORMAT	Move to the FORMAT EDIT screen to edit the selected format.

4.9.4 LABEL COMB. / DETAIL

LABEL COMB. / DETAIL						19-03-2014 (WED) 19:02	1/1
LABEL TYPE	PRINTER	FORMAT	CASSET.	LABEL PRINT		CONDITION	
NORMAL LABEL	PRINTER 1	52	1	YES	NO	NO CONDITION	
EYECATCH IMAGE LABEL	PRINTER 1	23	1	YES	NO	W/Eyecatch image	
EYECATCH PRICE LABEL	PRINTER 1	28	1	YES	NO	W/Campaign price	
CAMPAIGN COMMENT LABEL	PRINTER 1	0	1	YES	NO	W/Campaign comment	
CAMPAIGN ORIGIN LABEL	PRINTER 1	0	1	YES	NO	W/Campaign origin	
BARCODE LABEL	PRINTER 1	52	1	YES	NO	B LB: [BAR]	
INGREDIENTS ONLY LABEL	PRINTER 1	61	1	YES	NO	B LB: [INGREDIENTS]	
INGREDIENTS BARCODE LABEL	PRINTER 1	62	1	YES	NO	B LB: [INGREDIENTS]+[BA]	
TOTAL/SUBTTL	PRINTER 1	97	1	YES	NO	TOTAL/SUBTOTAL TOTAL LABEL	

FORMAT EDIT

INITIAL

Menu name	Specification
PRINTER	Display the printer for label printing. Move to the PRINTER SELECT screen.
FORMAT	Set the format to be used in the label printing. Input range: 1 to 999
CASSET.	Display the cassette No. to be used in the label printing.
LABEL PRINT	Set whether or not to perform label printing when the label printing conditions are satisfied.
CONDITION	Move to the PRINT CONDITION SELECT screen (When the label group is "reversely pasted label, total label", the print condition cannot be changed.)
FORMAT EDIT	To edit the selected format, move to the FORMAT EDIT screen.
INITIAL	Initialize the printing pattern.

4.10 LABEL FORMAT

LABEL FORMAT				MAR.14.2014 (FRI) 12:12PM		1/4	
No.	DESCRIPTION	WIDTH (mm)	HEIGHT (mm)				
1		60.0	60.0				
2		60.0	80.0				
3		60.0	82.0				
4	USA	56.0	73.0				
5	USA	56.0	59.0				
6	USA COUPON	56.0	84.0				
7	USA NUTRITION	56.0	146.0				
11	USA	56.0	60.0				
12		80.0	60.0				
20	TRACEABILITY	56.0	73.0				











Menu name	Specification
PRINT CONTROL	Open the PRINT CONTROL screen.
DETAIL	Move to the LABEL FORMAT/DETAIL (BASIC) screen.
DELETE	Return the selected format to the default status.
No.	Display the format No.
DESCRIPTION	Display the format title.
WIDTH	Set the format width. Input range: 0 to 800
HEIGHT	Set the format height. Input range: 0 to 2000

4.10.1 LABEL FORMAT / PRINT CONTROL

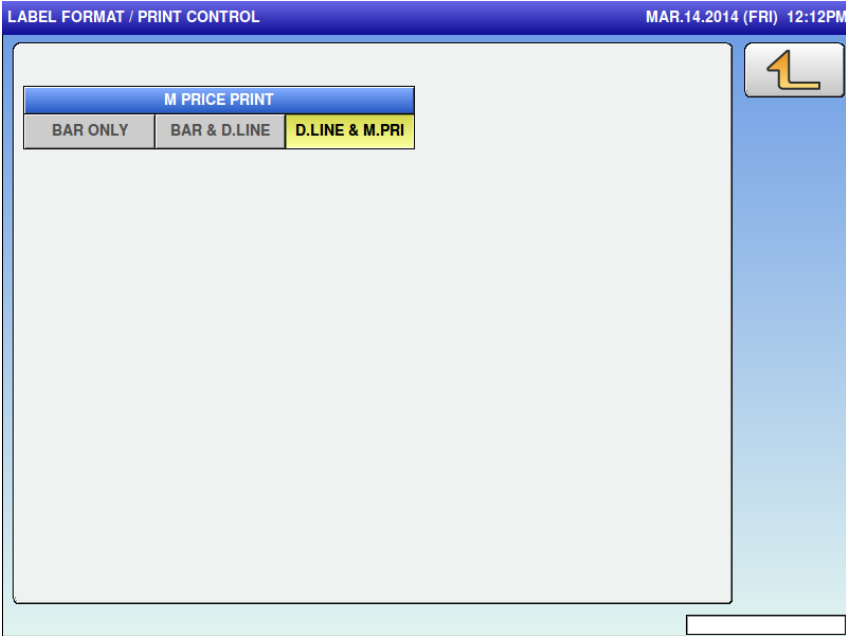

Menu name	Specification
M PRICE PRINT	Select the M price print. BAR ONLY / BAR & D. LINE / D. LINE & M.PRI

4.10.2 LABEL FORMAT / DETAIL (BASIC)

Menu name	Specification
FORMAT NAME	Touch the button to open the format name edit screen. Touch "<" and ">" located at both sides of the box to select the next (or previous) format master.
UNIT No.	Display the unit No. Touch the button to open the unit list set for the current format. The UNIT tab also has the same function.
UNIT NAME(ID)	Display the selected unit name. If nothing is selected, [HEADER] is selected.
PRINTER	Select the printer No.
PLU No.	Set the PLU No. to be used for the test print and preview. Input range: 1 to 99999999 For 0, print the checker label.
LABEL No.	Specify the label No. Input range: 1 to 99
WIDTH	Set the format width. Input range: 0 to 800
HEIGHT	Set the format height. Input range: 0 to 2000
Y-AXIS	Display the Y axis of selected unit. The axis is moved by entering the numerical number.

Menu name	Specification
FEED	Feed the label.
PRINT	Perform test printing by the format called and the item information set by PLU No.
UNIT ERASE	Delete the selected unit.
COPY	Enter the numerical number and press COPY to copy the said numerical number's format.
DELETE	Delete the format master. The dialog appears to ask whether to delete the format master.
←↑→↓	Move the axis of selected unit. If the HEADER is selected, the axis of whole format is moved.

4.10.3 LABEL FORMAT / DETAIL (UNIT)

LABEL FORMAT / DETAIL (UNIT) MAR.14.2014 (FRI) 8:05PM 1/1

1 < > STRING EDIT

UNIT No.	UNIT NAME	A	B	C	D	E	F
0	< HEADER >						

PLU	SET CONTENTS	VALUE
FORMAT No.	Header: 1-99 not able to change	1
X-AXIS	Able to set 0-08000 by 0.1mm	600
Y-AXIS	Able to set 0-2000 by 0.1mm	440
UNIT No.	Able to set 1-63	30
TURN	00:STANDARD 02:REVERSE	00

FEED PRINT UNIT ERASE UNIT COPY UNIT ADD

BASIC UNIT PREVIEW

Menu name	Specification
FORMAT NAME	Touch the button to open the format name edit screen. Touch "<" and ">" located at both sides of the box to select the next (or previous) format master.
STRING EDIT	Open the format string edit screen. Up to 526 bytes
UNIT No.	Display the unit No. Touch the button to open the unit list set for the current format. The UNIT tab also has the same function.
UNIT NAME(ID)	Display the selected unit name. If nothing is selected, "HEADER" is selected.
ABCDEF	Enter the alphabetical character. For hexadecimal entry.
PLU	Display the name of set item.
SET CONTENTS	Display the set contents.
VALUE	Enter the value for set contents.
FEED	Feed the label.
PRINT	Perform test printing by the format being called and the item information set by [PLU No.].
UNIT ERASE	Delete the selected unit.
UNIT COPY	Enter the numerical number and press COPY to copy the said numerical number's format.
UNIT ADD	Add the unit. The header unit also increases by one at the same time.

4.10.4 LABEL FORMAT / DETAIL (PREVIEW)

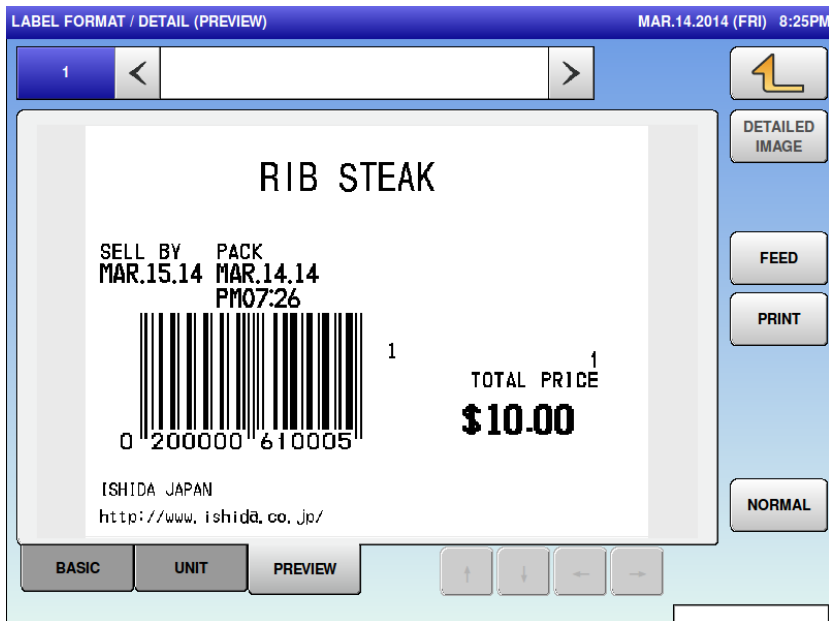

Menu name	Specification
DETAILED IMAGE /WHOLE IMAGE	Select the whole image or detailed image.
FEED	Feed the label.
PRINT	Perform test printing by the format called and the item information set by PLU No.
NORMAL	Set the label type to display. NORMAL / BARCODE / INGREDIENT / INGR. +BAR / SUBTOTAL / TOTAL
←↑→↓	Move the image. This function is enabled only for the detailed image.

4.11 BARCODE

4.11.1 BARCODE (POS FLAG)

BARCODE (POS FLAG) 07-03-2014 (FRI) 10:32

NON-PLU SET

EAN/UPC 13: 02 EAN/UPC 8: 2

PLU SET

10 DIGITS 13: 49 5 DIGITS 8: 49

POS FLAG POS CODE ITEM CODE

Menu name	Specification
EAN/UPC 13	Set the NON-PLU 13 digits. Input range: 00 to 99
EAN/UPC 8	Set the NON-PLU 8 digits. Input range: 0 to 9
10 DIGITS 13	Set the PLU 13 digits. Input range: 00 to 99
5 DIGITS 8	Set the PLU 8 digits. Input range: 00 to 99

4.11.2 BARCODE (POS CODE)

The screenshot shows a software interface for configuring barcode settings. The title bar reads 'BARCODE (POS CODE)' and the top right corner shows the date and time '07-03-2014 (FRI) 10:32'. The main area contains six menu items, each with a left arrow and a right arrow for navigation. The 'POS CODE TYPE' menu is currently selected and shows '1: EAN/UPC 13'. The 'OCR STYLE' menu shows 'EAN13' and 'UPC12'. The 'GS1 EXP FORMAT' menu shows '1:(01)(3922)(3203)'. The 'ITF FORMAT' menu shows 'FFCCCCPPPPW5/Q5(C/D)'. The 'POS FORMAT (WGT)' menu shows 'FFCCCC(C/P)PPPP(C/D)'. The 'POS FORMAT (FIX PRICE)' menu shows 'FFCCCC(C/P)PPPP(C/D)'. At the bottom of the screen, there are three buttons labeled 'POS FLAG', 'POS CODE', and 'ITEM CODE'. A yellow arrow icon is visible in the top right corner of the main area.

Menu name	Specification
POS CODE TYPE	Select the POS code type. 1: EAN/UPC13 2: EAN/UPC 8/3:10 DIGITS 13/4:5DIGITS 8/5:GS1 6:GS1 ST/7:GS1 STO/8:GS1 LIMITED/9:GS1 EXPANDED/10: ITF
OCR	Select the POS code type. 1: EAN/UPC13 2: EAN/UPC 8/3:10 DIGITS 13/4:5DIGITS 8/5:GS1 6:GS1 ST/7:GS1 STO/8:GS1 LIMITED/9:GS1 EXPANDED/10: ITF
GS1 EXP FORMAT	Select the GS1 EXP format. 1:(01) (3922) (3203) / 2:(01) (3922) (3203) (15)
ITF FORMAT	Set the format when POS CODE TYPE is [ITF].
POS FORMAT(WGT)	Select the POS format (weight). Touch the button to open the POS FORMAT list. Select the format from the list.
POS FORMAT (FIX PRICE)	Select the POS format (fix price). Touch the button to open the POS FORMAT list. Select the format from the list.

4.11.3 BARCODE (ITEM CODE)

BARCODE (ITEM CODE) 07-03-2014 (FRI) 10:32

DEPARTMENT No. DIGIT SET

1	2	3	4	5	6	7	8
---	---	---	---	---	---	---	---

GROUP No. DIGIT SET

1	2	3	4	5	6	7	8
---	---	---	---	---	---	---	---

EAN/UPC 13 DIGIT SET

1	2	3	4	5	6	7	8
---	---	---	---	---	---	---	---

EAN/UPC 8 DIGIT SET

1	2	3	4	5	6	7	8
---	---	---	---	---	---	---	---

POS FLAG POS CODE ITEM CODE

Menu name	Specification
DEPARTMENT No. DIGIT SET	<p>Execute the digit set of department No.</p> <p>Press the numerical number to switch the selection.</p> <p>Press the numerical number in series.</p> <p>(e.g. The combination of "1" and "3" cannot be selected. The combination of "1", "2" and "3" can be selected.)</p>
GROUP No. DIGIT SET	<p>Execute the digit set of group No.</p> <p>Press the numerical number to switch the selection.</p> <p>Press the numerical number in series.</p> <p>(e.g. The combination of "1" and "3" cannot be selected. The combination of "1", "2" and "3" can be selected.)</p>
EAN/UPC 13 DIGIT SET	<p>Execute the digit set of JAN code (13 digits).</p> <p>Press the numerical number to switch the selection.</p> <p>Press the numerical number in series.</p> <p>(e.g. The combination of "1" and "3" cannot be selected. The combination of "1", "2" and "3" can be selected.)</p>
EAN/UPC 8 DIGIT SET	<p>Execute the digit set of JAN code (8 digits).</p> <p>Press the numerical number to switch the selection.</p> <p>Press the numerical number in series.</p> <p>(e.g. The combination of "1" and "3" cannot be selected. The combination of "1", "2" and "3" can be selected.)</p>

4.12 CUSTOM BARCODE

Menu name	Specification
ITEMS	Switch the display items between "10 items" and "20 items".
DETAIL	Move to the CUSTOM BARCODE (BASIC) screen, and display the details of custom bar code in selection.
DELETE	Delete the selected line.
SEARCH TEXT	<p>Move to the CUSTOM BARCODE / SEARCH TEXT EDIT screen.</p>
SEARCH	<p>Switch the search condition between [SEARCH] and [CANCEL].</p> <p>SEARCH: Display data including [SEARCH TEXT] in a list. CANCEL: Display all the data in a list.</p>

4.12.1 CUSTOM BARCODE (BASIC)

CUSTOM BARCODE (BASIC) MAR.14.2014 (FRI) 10:24AM 1/1

1 < MEAT >

No.	ID	START	DIGIT	DATA	CTRL
1	PLU No.	1	0:ALL	00000001	0:NONE
2	POS CODE	1	0:ALL	0000000000	0:NONE
3	SELL-BY DATE	1	0:ALL	20140315	0:NONE
4					

PLU 1
FORMAT 1
FORMAT EDIT
INSERT
DELETE

BASIC PREVIEW

Menu name	Specification
PLU	Set the item No. to be used for the preview. Input range: 1 to 99999999 Other tabs also have the same function.
FORMAT	Input range: 1 to 999 Other tabs also have the same function.
FORMAT EDIT	Open the format edit screen. Other tabs also have the same function.
INSERT	Insert the blank line in front of selected line.
DELETE	Delete the selected line.
No.	Touch the button to switch the selection.
ID	Set the ID to be combined. Touch the button to open the CUSTOM BARCODE ID LIST. Select the ID from the list.
START	Set the start digit. Input range: 1 to 999
DIGIT	Set the digit number. 0: ALL or 1 to 999
DATA	Display the set ID data. Touch the button to open the edit screen only when the ID is set to PRE PRINT.
CTRL	Select the control character. 0: NONE 1: ()

4.12.2 CUSTOM BARCODE (PREVIEW)

CUSTOM BARCODE (PREVIEW) MAR.14.2014 (FRI) 10:25AM

1 < MEAT >

00000001000000000020140315

PLU
1

FORMAT
1

FORMAT
EDIT

INSERT

DELETE

BASIC PREVIEW

Menu name	Specification
	The combined-barcode preview is displayed only.

4.13 MENU TITLE

4.13.1 MENU TITLE (OPERATE)

MENU TITLE (OPERATE) 07-03-2014 (FRI) 15:41 1/1

No.	DEFAULT NAME	NEW NAME
1001	PREPACK	PREPACK
1003	ACC1	ACC1
1004	ACC2	ACC2
1005	ACC3	ACC3
1002	TOTAL ADJUST	TOTAL ADJUST

OPERATE TOTAL PROGRAM SETUP ADJUST EDIT

Menu name	Specification
DEFAULT NAME	Display the menu name before editing. Touch the button to select the menu name.
NEW NAME	Display the menu name after editing. Touch the button to select the menu name.
EDIT	Transfer to the edit screen of the selected menu name.

(All tabs have the same operations so their explanations are omitted here.)

4.14 OPERATION SETTING

4.14.1 OPERATION SETTING (CALL1)

OPERATION SETTING (CALL1) 12-03-2014 (WED) 17:10

FIND PLU

START CHAR. | LINE1 | LINE2 | ALL

FREEMASTER FOR URL
15

PACK MODE HOLD
FIXING | ITEM EACH

TORQUE WRAPPING PLU
0

CALL1 | CALL2 | PROD. | PRINT

Menu name	Specification
FIND PLU	Select how to search PLU. START CHAR. / LINE1 / LINE2 / ALL
FREEMASTER FOR URL	Set the freemaster No. to use in the URL. Input range: 0 to 15
PACK MODE HOLD	Select the PACK mode between "fixed to scale" or "set by item". FIXING / ITEM EACH

TORQUE WRAPPING PLU

Specify the product number for torque wrapping.

Input range: 0 to 999999999

When the number specified in production mode is called, the wrapping operation starts and the torque wrapping is automatically set.

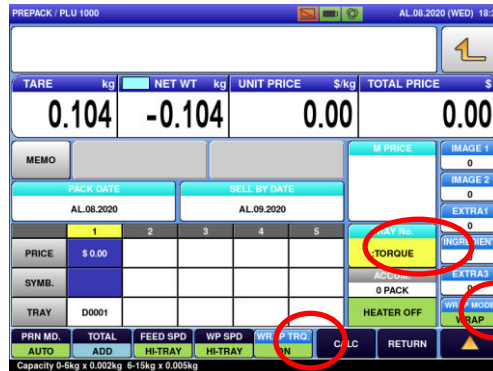

When the torque wrapping is executed, the camera recognizes lengths of the short side and long side, and the upper or lower film is selected for the dual-film type.

At the time of wrapping, the squeezing degree of the right/left wrapping plates and the rear wrapping plate are determined by the DC brushless torque (current).

Priority is given to not breaking the tray, so if the wrapping becomes too strong, wrapping will stop temporarily and the squeezing operation is executed again. Some trays may have some wrinkles.

Note:

When the call number for which a tray is registered is specified for torque wrapping, the number is set as torque wrapping, and therefore only wrapping can be performed but the labeling cannot be performed.

4.14.2 OPERATION SETTING (CALL2)

OPERATION SETTING (CALL2) 12-03-2014 (WED) 17:10

CALL UP UNIT PRICE

EVERY U/P No. 1 LAST CALL UP U/P

CHANGE MASTER

BARCODE TYPE POS REFERENCE POS FLAG BARCODE POS FORMAT(WGT)	POP MSG.	FEED SPEED
PLU U/P	PLU U/P	PLU U/P
	REG. CODE	PASTE MODE
	PLU U/P	PLU U/P
IMAGE 1	IMAGE 2	IMAGE 3
PLU U/P	PLU U/P	PLU U/P
EXTRA MSG. 1	INGREDIENT	EXTRA MSG. 3
PLU U/P	PLU U/P	PLU U/P

CALL1 CALL2 PROD. PRINT

Menu name	Specification
CALL UP UNIT PRICE	Select and set the unit price to be set in the PLU calling. EVERY U/P No.1: 1 is selected for the unit price. LAST CALL UP U/P: the unit No. used latest is selected.
CHANGE MASTER	Select and set the method to be used for each item. PLU: Data permanently set to unit 1 is used. U/P: Data set for each unit is used.

4.14.3 OPERATION SETTING (PROD.)

OPERATION SETTING (PROD.) MAR.13.2014 (THU) 4:53PM

WEIGHTED ITEMS' WEIGHT RANGES CHECK

NO
YES

TARE SELECT

1st TARE
2nd TARE

FIX PRICE ITEMS' WEIGHT RANGES CHECK

NO
YES

@for SET

NO
YES

END OF DAY

16

MEAT CUT TEST

NO
YES

FIX UPR POP UP

NO
YES

MEAT CUT TEST DEL. SELECT

NON USE
USE

CALL1
CALL2
PROD.
PRINT

Menu name	Specification
WEIGHED ITEMS'WEIGHT RANGES CHECK	Select whether or not to check the weight of weighed items. NO / YES
TARE SELECT	Select the tare. 1st TARE / 2nd Tare
FIX PRICE ITEMS' WEIGHT RANGES CHECK	Select whether or not to check the weight of fixed-price product. NO / YES
@for SET	Select and set whether to perform @for calculation (for the fixed price item using "x (MULTI)" key). *Settable only when the country is set to [USA] NO / YES
END OF DAY	Set the time valid for the next day process set for PLU. Input range: 0 to 23
MEAT CUT TEST	Select and set whether to use the Meat Cut Weight Control mode. NO / YES
FIX UPR POP UP	In calling the fixed price item, select and set whether to display the popup display for fixed weight setting. NO / YES
MEAT CUT TEST DEL. SELECT	Select and set whether to use the DELETE button in the Meat Cut Master Setting screen. NON USE / USE

4.14.4 OPERATION SETTING (PRINT.)

OPERATION SETTING (PRINT) 25-04-2014 (FRI) 9:31

ORDER COMPRECACTION SETUP			AUTO SUBTOTAL LABEL		
NONE	BUZZER	MESSAGE	NONE	1	2
TARGET AUTO SETUP			AUTO/MANUAL		
NONE	YES		AUTO	MANUAL	
SUBTOTAL CLEAR			UPPER BAR WHEN UNDER LABEL PRINT		
SUBTOTAL PRINT	PLU CALL		NO PRINT	PRINT	

CALL1 CALL2 PROD. PRINT

Menu name	Specification
ORDER COMPRECACTION SETUP	Select and set the operation when the order is completed. NONE / BUZZER / MESSAGE
AUTO SUBTOTAL LABEL	Select printing of the automatic subtotal label. NONE: Printing is not performed. 1: 1 sheet of subtotal label is printed. 2: 2 sheets of subtotal label are printed. Settable only when the order completion operation selects [MESSAGE].
TARGET AUTO SETUP	Selecting YES sets the same target No. when the target No. setting is completed.
SUBTOTAL CLEAR	Select and set the clear timing of the subtotal data. SUBTOTAL PRINT: Cleared when the subtotal is printed PLU CALL: Cleared when the item is called
AUTO/MANUAL	Select and set the initial value of [PRN MD.] when the screen is moved to OPERATE MODE.
UPPER BAR WHEN UNDER LABEL PRINT	Select and select whether to print the barcode of the 1st LABEL when the 2nd LABEL is printed.

4.15 ERROR PROCESS

4.15.1 ERROR PROCESS (ISSUE)

ERROR PROCESS (ISSUE) 07-03-2014 (FRI) 16:06

PRINTING AT €0 PRICE

BARCODE=0 No PRICE / No BAR. PRICE=0 / No BAR. No PRICE

DISPLAY ERROR: TARE WEIGHT NOT SET

NO / YES

DISPLAY ERROR: ZERO (€ 0) PRICE

NO / YES

PLU NAME LINES OVER ERROR

ERROR / LINE CUT

ISSUE CALL COMMON

Menu name	Specification
PRINTING AT 0 PRICE	Select the action of printing at 0. BARCODE=0 No PRICE / No BAR.PRICE=0 / No BAR. No PRICE The currency unit depends on the country master.
DISPLAY ERROR: TARE WEIGHT NOT SET	Select whether or not to display the error message when the tare weight is not set. NO / YES
DISPLAY ERROR: ZERO PRICE	Select whether or not to display the error message of 0 price. NO / YES
PLU NAME LINES OVER ERROR	Select and set the process when the item line No. is over the set number. ERROR: Display the LINE OVER error, and no item is printed. LINE CUT: Cut the exceeded line, and the item is printed within the display range.

4.15.2 ERROR PROCESS (CALL)

ERROR PROCESS (CALL) APR.21.2014 (MON) 7:36PM

NO POS CODE SET ERROR

NO ERROR DISPLAY	NO LABEL PRINT	NO BAR PRINT
-------------------------	----------------	--------------

ERROR PROCESS

EXTRA MSG.1 NO YES	INGREDIENT NO YES	EXTRA MSG.3 NO YES	COUPON MSG. NO YES
POP MSG. NO YES	FREE MSG.1 NO YES	FREE MSG.2 NO YES	FREE MSG.3 NO YES
FREE MSG.4 NO YES	FREE MSG.5 NO YES	FREE MSG.6 NO YES	FREE MSG.7 NO YES
FREE MSG.8 NO YES	FREE MSG.9 NO YES	FREE MSG.10 NO YES	FREE MSG.11 NO YES
FREE MSG.12 NO YES	FREE MSG.13 NO YES	FREE MSG.14 NO YES	FREE MSG.15 NO YES

ISSUE	CALL	COMMON
-------	------	--------

Menu name	Specification
NO POS CODE SET ERROR	Select the action when the POS code is not set. NO ERROR DISPLAY / NO LABEL PRINT / NO BAR PRINT
ERROR PROCESS	Set the error display operation when the link master at item calling does not exist. NO / YES

4.15.3 ERROR PROCESS (COMMON)

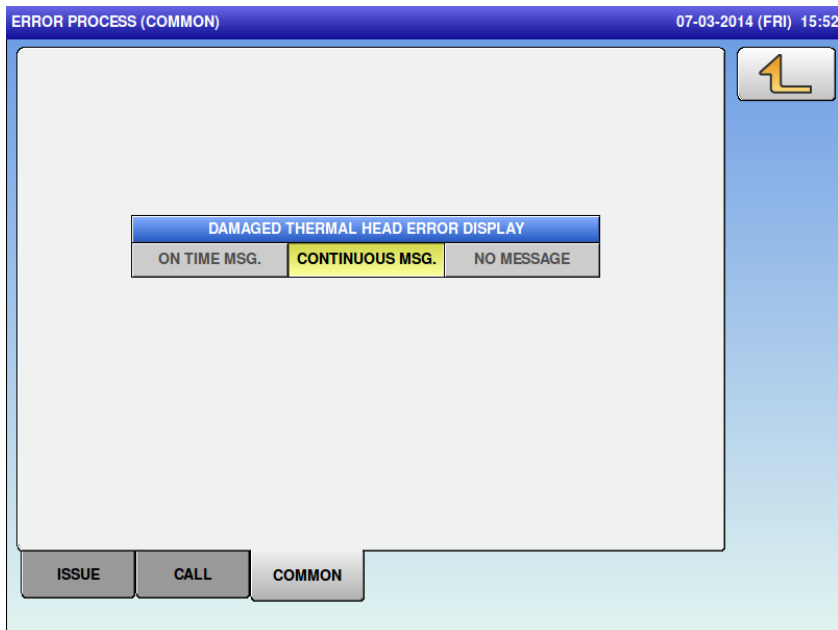

Menu name	Specification
DAMAGED THERMAL HEAD ERROR DISPLAY	Select how to set the error message of damaged thermal head. ON TIME MSG / CONTINUOUS MSG / NO MESSAGE

4.16 ERROR LOG

4.16.1 ERROR LOG (DISPLAY)

ERROR LOG (DISPLAY)					13-03-2014 (THU) 17:37		1/25	
DATE/TIME	ERROR No.	PLU	TRAY	ERROR DESCRIPTION				
03/13 17:30:35	0459-0000	0	0	MACHINE IS RETURNING TO STAND BY POSITION				
03/13 17:30:35	0322-0000	0	0	GO BACK TO ORIGINAL POSITION				
03/13 17:30:28	0801-0001	0	0	CAN NOT COMMUNICATE WITH PRINTER 2				
03/13 17:30:24	0361-0000	0	0	POWER IS ON				
03/13 17:27:28	19006-0000	20140313	0	POWER OFF				
03/13 17:27:00	0459-0000	0	3	MACHINE IS RETURNING TO STAND BY POSITION				
03/13 17:12:21	0459-0000	0	0	MACHINE IS RETURNING TO STAND BY POSITION	LOG LEVEL			
03/13 17:12:20	0322-0000	0	0	GO BACK TO ORIGINAL POSITION	ERR.+OPE.			
03/13 17:12:00	0801-0001	0	0	CAN NOT COMMUNICATE WITH PRINTER 2				
03/13 17:11:56	0361-0000	0	0	POWER IS ON				

DISPLAY DELETE

Menu name	Specification
LOG LEVEL	Select the error log level to be displayed on the list. ONLY ERR. / ERR. +OPE.
DELETE	Delete the error log. The DELETE CHECK dialog appears to ask whether to delete the error log.

4.17 TRACE.

TRACE. 07-03-2014 (FRI) 19:22

TRACEABILITY TYPE
 TYPE1 TYPE2

TRACEABILITY TOTAL
 NON ADD ADD

LOOKUP TABLE EDIT
 NO YES

TRACE. DATA DELETE
 MANUAL AUTO

TRACEABILITY PASSWORD
 0000

Menu name	Specification
TRACEABILITY TYPE	Select the traceability type. TYPE1 / TYPE2 (TYPE1 is simple traceability.)
TRACEABILITY TOTAL	Select whether or not to add the traceability total. NO / YES
TRACE. DATA DELETE	Select the manual or auto deletion of traceability data. MANUAL / AUTO
TRACEABILITY PASSWORD	Set the traceability password. This function is enabled when [TYPE2] is selected in the TRACEABILITY TYPE. 0 or 4-digit number
LOOKUP TABLE EDIT	Select whether or not to enable the lookup table edit on the traceability screen in the normal mode. NO / YES

4.18 DUAL CURRENCY

DUAL CURRENCY 10-03-2014 (MON) 15:31

EXCH. RATE 4293	EXCH. RATE DEC. PNT. POS. 4
PERIOD SELECTION	
LOCAL+FOREIGN	FOREIGN+LOCAL
LOCAL	FOREIGN
LOCAL CURRENCY SYMBOL Lm	LOCAL CURR. DEC. PNT. POS. 3

Menu name	Specification
EXCH. RATE	Set the exchange rate of the second currency. Input range: 0 to 99999999
EXCH. RATE DEC. PNT. POS.	Set the decimal point position of the exchange rate of the second currency. Input range: 0 to 7
PERIOD SELECTION	Select the currency combination. LOCAL+FOREIGN/FOREIGN+LOCAL/LOCAL/FOREIGN
LOCAL CURRENCY SYMBOL	Set the local currency symbol. Up to 3 bytes
LOCAL CURR. DEC. PNT. POS.	Set the decimal point position of the local currency. Input range: 0 to 7

4.19 PRICE ROUNDING

PRICE ROUNDING 10-03-2014 (MON) 20:19

PRICE ROUNDING		DISCOUNT ROUNDING		
4/5	05	DOWN	4/5	UP

Menu name	Specification
PRICE ROUNDING	Select the price rounding type. 4/5 / 05
DISCOUNT ROUNDING	Select the discount rounding type. DOWN / 4/5 / UP

4.20 FREQUENT SHOPPER

FREQUENT SHOPPER 11-03-2014 (TUE) 8:50

1

BARCODE PRICE TYPE

NORMAL MARKDOWN

LOGO IMAGE 1 No.

000

Menu name	Specification
BARCODE PRICE TYPE	Select the barcode price type. NORMAL / MARKDOWN
LOGO IMAGE 1 No.	Set the logo image 1 No. Input range: 0 to 999

4.21 STANDBY MODE

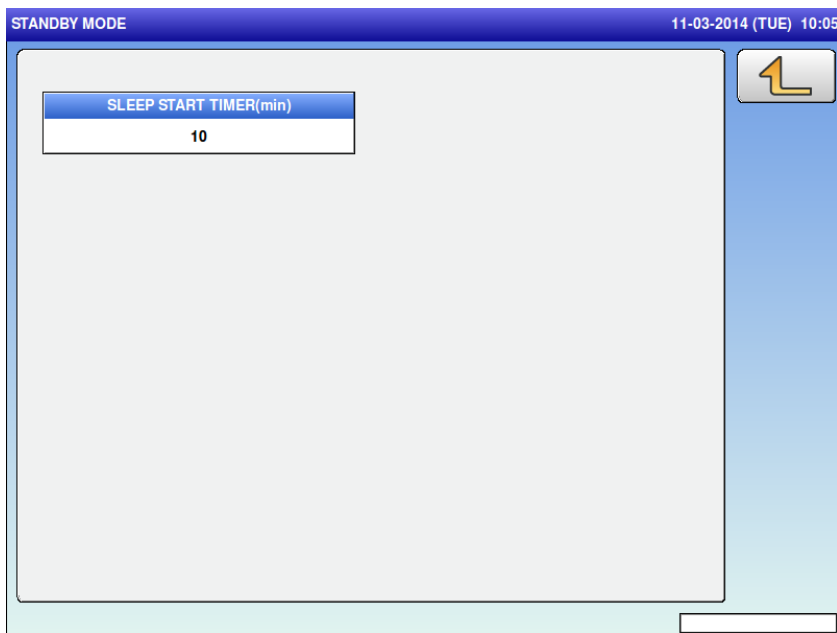

Menu name	Specification
SLEEP START TIMER(min)	Set the time to standby mode. The unit is in minutes.

4.22 COUNTRY

Menu name	Specification
COUNTRY	<p>Select the country.</p> <p>Enter 951753 and press PLU to enable this function.</p> <p>Touch the COUNTRY button to open the list and select the country.</p>
LANGUAGE	<p>Set the first to third language.</p> <p>Touch the button to open the list and select the language.</p>
DETAIL	<p>Transfer to the country setting details screen.</p> <p>Enter 495344 and press PLU to open the screen.</p>

4.22.1 COUNTRY / DETAIL (CURRENCY)

COUNTRY / DETAIL (CURRENCY) 11-03-2014 (TUE) 12:03

1

CURRENCY SYMBOL: €

TEMPERATURE: °C / F

DEC. POINT POSITION: 2

DEC. POINT TYPE: . / ,

INIT.

CURRENCY WEIGHT DATE

Menu name	Specification
CURRENCY SYMBOL	Set the currency symbol. Up to 3 bytes
DEC. POINT POSITION	Set the decimal point position of currency. Input range: 0 to 7
DEC. POINT TYPE	Select the decimal point type. . / , (dot / comma)
TEMPERATURE	Select and set the temperature unit. °C / F
INIT.	Initialize the set value of country master. Other tabs also have the same function.

4.22.2 COUNTRY / DETAIL (WEIGHT)

COUNTRY / DETAIL (WEIGHT) 11-03-2014 (TUE) 16:43

WEIGHT UNIT			MAX. TARE		
lb	kg	g	5998		
DEC. POINT POSITION			MINIMUM PRINT WGT		
3			20e	5e	3e
DEC. POINT TYPE					
.			,		

INIT.

CURRENCY WEIGHT DATE

Menu name	Specification
WEIGHT UNIT	<p>Select the weight unit.</p> <p>Lb / kg / g</p> <p>Enter 14789632 and press PLU to enable this function.</p>
MAX. TARE	<p>Set the maximum tare.</p> <p>For the unit of kg or g: 0 to 5998 For the unit of lb: 0 to 9990</p> <p>Enter 14789632 and press PLU to enable this function.</p>
DEC. POINT POSITION	<p>Set the decimal point position.</p> <p>Input range: 1 to 5</p> <p>Enter 495344 and press PLU to enable this function.</p>
DEC. POINT TYPE	<p>Select the decimal point type.</p> <p>./, (dot / comma)</p> <p>Enter 495344 and press PLU to enable this function.</p>
MINIMUM PRINT WGT	<p>Set the minimum print weight.</p> <p>20e / 5e / 3e</p> <p>Enter 495344 and press PLU to enable this function. This function is enabled only for the manual print.</p>
INIT.	<p>Initialize the set value of country master.</p> <p>Other tabs also have the same function.</p>

4.22.3 COUNTRY / DETAIL (DATE)

COUNTRY / DETAIL (DATE) 11-03-2014 (TUE) 12:03

DATE FORMAT: < 2:D-M-Y >

DATE SPACER: , . : / SPC ymd -

YEAR TYPE: YY(2) YYYY(4)

SHELF LIFE-USE BY: Next Day Today

MONTH TYPE: DIGIT CHAR.(3) CHAR.(2)

INIT.

CURRENCY WEIGHT DATE

Menu name	Specification
DATE FORMAT	Select the date format (order). 0: Y-M-D / 1:M-D-Y / 2: D-M-Y
YEAR TYPE	Select the year type. YY (2) / YYYY (4) Last 2 or 4 digits
MONTH TYPE	Select the month type. DIGIT / CHAR (3) / CHAR (2) Numerical number, three characters or two characters
DATE SPACER	Select the date spacer. , (comma) / . (period) / :(colon) / /(slash) / space / ymd / • (middle point)
SHELF LIFE-USE BY	Select whether or not to set the shelf life "1" to the next day or today. Next Day / Today
INIT.	Initialize the set value of country master. Other tabs also have the same function.

4.23 FILE SAVE /LOAD

4.23.1 FILE SAVE/LOAD (USB>SCALE)

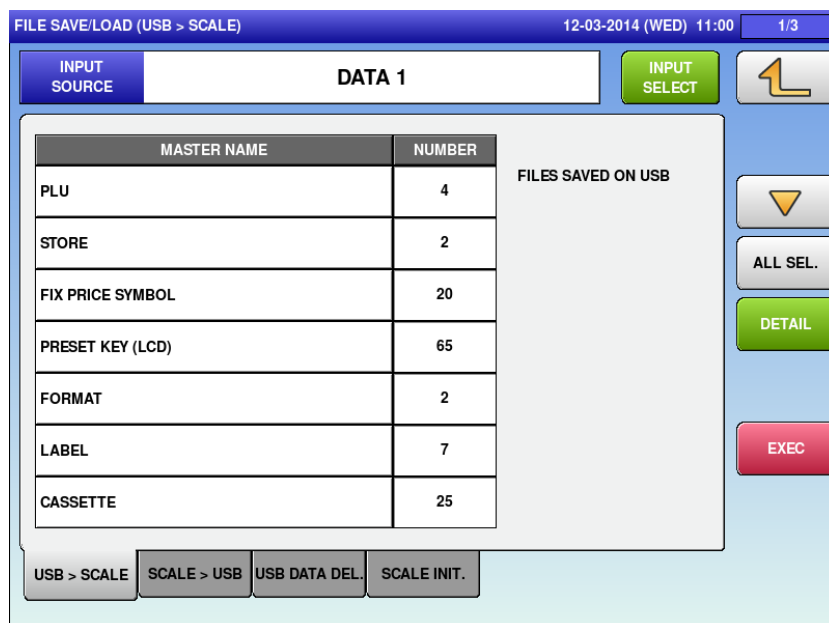

Menu name	Specification
INPUT SOURCE	Display the name of the input source.
INPUT SELECT	Open the FILE SAVE/LOAD IN SELECT screen. The input source is listed only when the files are saved on the USB flash drive.
MASTER NAME	Display the master name. Touch the button to change the selection. Other tabs also have the same function.
NUMBER	Display the number of master data. Other tabs also have the same function.
ALL SEL.	Change the selections of all masters. This function is enabled when the input source file is set. Other tabs also have the same function.
DETAIL	Open the FILE SAVE/LOAD OUT (DETAIL) screen. Other tabs also have the same function.
EXEC	Execute the file input of selected master. The INPUT CHECK dialog appears to ask whether to input the file.

4.23.2 FILE SAVE/LOAD (SCALE>USB)

FILE SAVE/LOAD (SCALE > USB) 12-03-2014 (WED) 11:02 1/9

OUT SOURCE DATA 1 OUTPUT SELECT

MASTER NAME	NUMBER
PLU	4
STORE	2
FIX PRICE SYMBOL	20
FREE MSG.1	0
FREE MSG.2	0
FREE MSG.3	0
FREE MSG.4	0

ALL SEL. DETAIL EXEC

USB > SCALE SCALE > USB USB DATA DEL. SCALE INIT.

Menu name	Specification
OUT SOURCE	Display the name of the output source.
OUTPUT SELECT	Open the FILE SAVE/LOAD OUT SELECT screen. SET: Set the output source. EDIT: Edit the name of the output source.
ALL SEL.	Switch between "All items selected" / "All items unselected".
DETAIL	Move to the FILE SAVE/LOAD / DETAIL screen.
EXEC	Execute the file output of selected master. The OUTPUT CHECK dialog appears to ask whether to output the file.

4.23.2.1 FILE SAVE/LOAD / OUTPUT SELECT

FILE SAVE/LOAD / OUTPUT SELECT		12-03-2014 (WED) 11:02	1/1
No.	INPUT		
1	DATA 1	 EDIT SET	
2			
3			
4			
5			
6			
7			
8			
9			
10			

Menu name	Specification
No.	Display the folder No. displayed in the USB memory. Folder "Data01" to "Data10" = №1 to №10
INPUT	Display the data name (index name) named to each master file group "Data01" to "Data10" memorized in the USB memory.
EDIT	Move to the FILE SAVE/LOAD / OUTPUT SELECT / EDIT INDEX NAME screen.
SET	Determine the input source selected, and return to the previous screen.

4.23.3 FILE SAVE/LOAD (USB DATA DEL.)

FILE SAVE/LOAD (USB DATA DEL.) 12-03-2014 (WED) 11:06 1/4

DELETE SOURCE DATA 1 DELETE SELECT

MASTER NAME	NUMBER
PLU	4
STORE	2
FIX PRICE SYMBOL	20
PRESET KEY (LCD)	65
FORMAT	2
LABEL	7
CASSETTE	25

ALL SEL. DETAIL EXEC

USB > SCALE SCALE > USB USB DATA DEL. SCALE INIT.

Menu name	Specification
DELETE SELECT	Display the name of the deletion source.
MASTER NAME	Display the master name of the file in the folder of USB memory specified as "Deletion destination".
ALL SEL.	Switch between "All items selected" / "All items unselected".
EXEC	Execute the file output of selected master. The OUTPUT CHECK dialog appears to ask whether to output the file.

4.23.3.1 FILE SAVE/LOAD / DELETE SELECT

FILE SAVE/LOAD / DELETE SELECT		12-03-2014 (WED) 11:03	1/1
No.	INPUT		
1	DATA 1	 ALL DEL ERASE SET	
2			
3			
4			
5			
6			
7			
8			
9			
10			

Menu name	Specification
No.	Display the folder No. memorized in the USB memory. Folder "Data01" to "Data10" = No.1 to No.10
INPUT	Display the data name (index name) named to each master file group "Data01" to "Data10" memorized in the USB memory.
ALL DEL	Delete all the files in the USB memory (folders "Data01" to "Data10").
ERASE	Delete all the files in the selected data folder.
SET	Determine the input source selected, and return to the previous screen.

4.23.4 FILE SAVE/LOAD (SCALE INIT.)

FILE SAVE/LOAD (SCALE INIT.) 12-03-2014 (WED) 11:06 1/9

DATA INTERNAL MASTER

MASTER NAME	NUMBER
PLU	4 (4)
STORE	2
FIX PRICE SYMBOL	20
FREE MSG.1	0
FREE MSG.2	0
FREE MSG.3	0
FREE MSG.4	0

MEMORY SPACE
1,547,860 KB

PLU MASTER CONV.
1763079 EA

ALL SEL.

DETAIL

EXEC

USB > SCALE SCALE > USB USB DATA DEL. SCALE INIT.

Menu name	Specification
DATA	Display the master name. Touch the button to change the selection.
MASTER NAME	Display the master name in the scale. Line selection/deselection is available.
NUMBER	Display the data No. of the master inside the scale.
MEMORY SPACE	Display the memory space inside the scale in kilobyte (kB).
PLU MASTER CONV.	Display the approximate value about how many items master can store in the free space.
ALL SEL.	Switch between "All items selected" / "All items unselected".
EXEC	Initialize the selected master. The INITIALIZATION CHECK dialog appears to ask whether to initialize the master.

4.23.5 FILE SAVE/LOAD / DETAIL

FILE SAVE/LOAD / DETAIL 12-03-2014 (WED) 16:26

The screenshot shows a software interface with a blue header bar containing the text 'FILE SAVE/LOAD / DETAIL' and the date/time '12-03-2014 (WED) 16:26'. Below the header is a large white area with a light blue border. In the top right corner of this area is a yellow arrow icon pointing up and left. The main content consists of four vertically stacked sections, each with a blue title bar and two selectable options in a grey box:

- RENEW CONTROL**: Options are 'NO' (selected, highlighted in yellow) and 'YES'.
- TRAY LIMIT**: Options are 'LIMIT' and 'NON LIMIT' (selected, highlighted in yellow).
- CHARACTERS OUT TYPE**: Options are 'CONTROL CODE NO' and 'CONTROL CODE YES' (selected, highlighted in yellow).
- INPUT MODE**: Options are 'CHANGE' (selected, highlighted in yellow) and 'ADDITION'.

Menu name	Specification
RENEW CONTROL	Select whether or not to control update. NO / YES
TRAY LIMIT	Select whether or not to limit the tray. LIMIT / NO LIMIT
CHARACTERS OUT TYPE	Select the character output type. CONTROL CODE NO / CONTROL CODE YES [CONTROL CODE NO] cannot be selected.
INPUT MODE	Select the input mode. CHANGE / ADDITION

Chapter 5 Adjust Mode

5.1 Startup

Turn on the power.

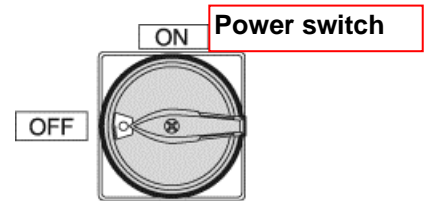

The PREPACK screen in the OPERATE mode appears.

Press  at the upper right side of the screen.



The menu appears in the OPERATE MODE.

Press the [ADJUST] button on the screen.

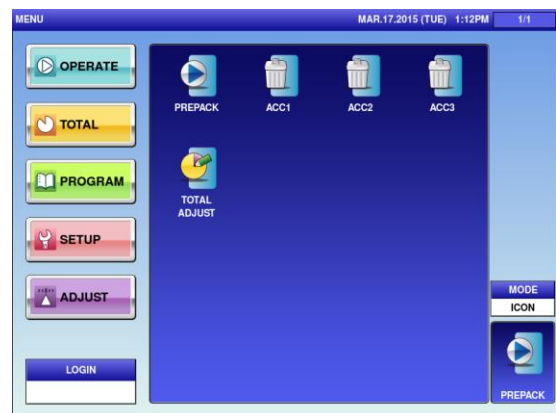

The User Menu screen in the ADJUST mode appears.

Input the password "495344" using the numerical keys, and press the [LOGIN] button on the screen.

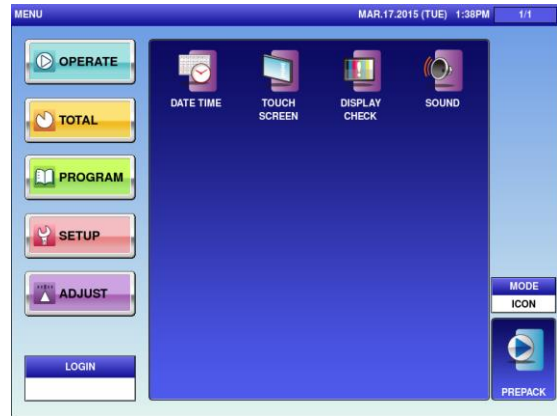
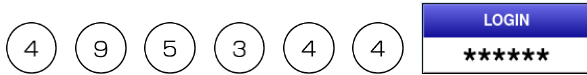

The Maintenance Menu screen appears in the ADJUST mode.



Maintenance Menu screen 1/2



Maintenance Menu screen 2/2

5.2 DATE TIME

DATE TIME NOV.15.2013 (FRI) 04:24PM

DATE NOV.15.2013

TIME 04:11:45PM

KEYIN LEN/DATE FORMAT
 1-2 : DD
 3-4 : MM-DD
 8 : MM-DD-YYYY

JULIAN DATE
 319-2013

KEYIN LEN/TIME FORMAT
 1-2 : SS
 3-4 : MM:SS
 5-6 : HH:MM:SS

SET

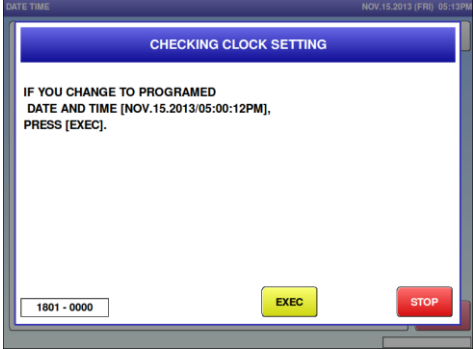
Menu name	Specification
	<p>Return to Menu. When any change is made, save the setting (with confirmation message).</p> 
DATE	<p>Enter the date conforming to KEYIN LEN/DATE FORMAT.</p> <p>If "21022013" is entered, "21-02-2013" is displayed. If "20" is entered, "20-02-2013" is displayed. If "2003" is entered, "20-03-2013" is displayed.</p>
TIME	<p>Enter the time conforming to KEYIN LEN/TIME FORMAT.</p> <p>If "00" is entered, "17:53:00" is displayed. If "2000" is entered, "17:20:00" is displayed. If "152000" is entered, "15:20:00" is displayed.</p>
JULIAN DATE	<p>Display the number of days counted from January 1.</p>
TIME ZONE	<p>Set the time zone. When pressing this button without numeric value, the time zone list is displayed according to country setting. When pressing it with 495344 entered, the entire time zone list is displayed.</p>

	
<p>SET</p>	<p>Set the entered date and time.</p> <p>The CHECKING CLOCK SETTING dialog appears to ask whether to change the date and time.</p>

5.3 TOUCH SCREEN

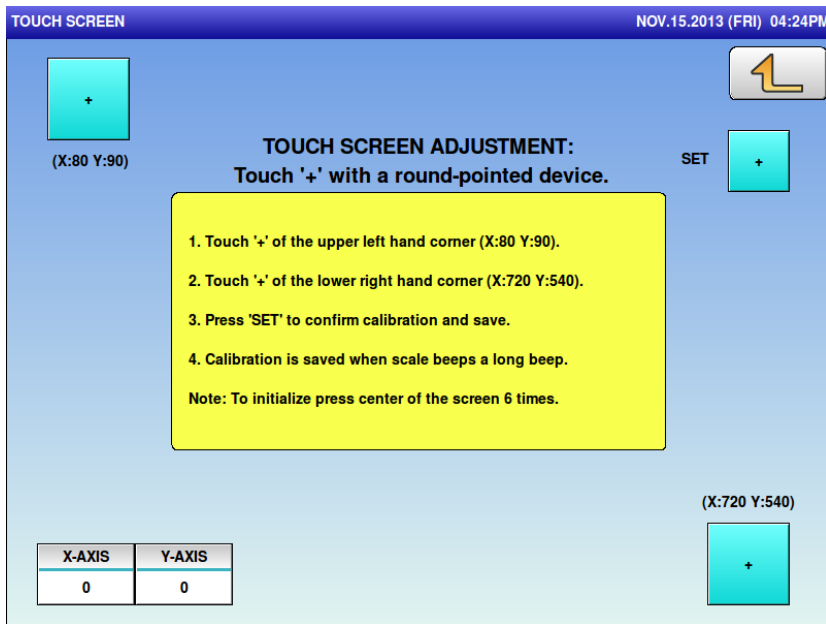

Menu name	Specification
	For initialization of touch panel, press center of the screen 6 times.

5.4 DISPLAY CHECK

● HORIZONTAL screen

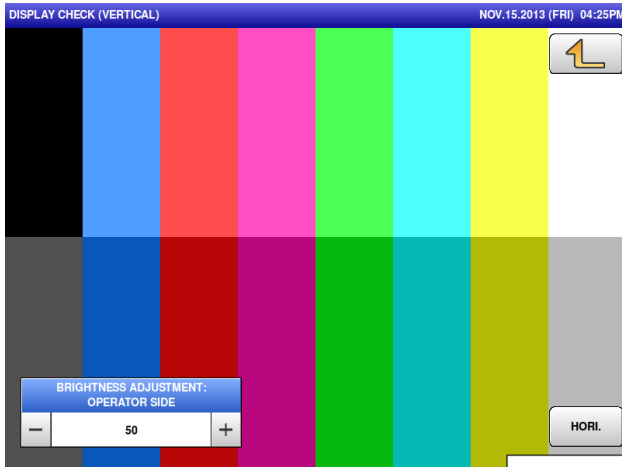

● VERTICAL screen

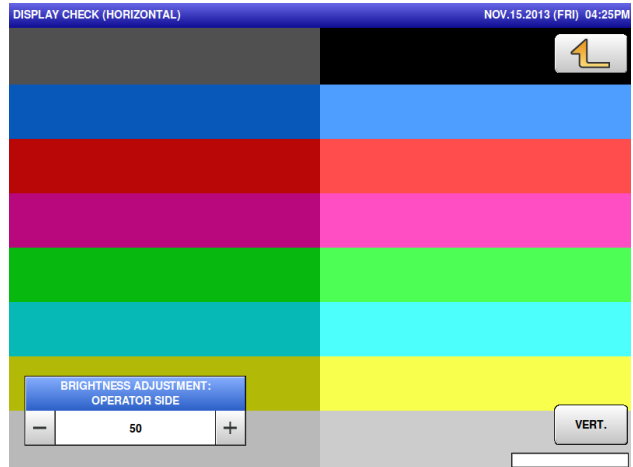

Menu name	Specification
BRIGHTNESS ADJUSTMENT: CUSTOMER SIDE	Adjust the brightness of customer-side display. Input range: 0 to 100
BRIGHTNESS ADJUSTMENT: OPERATOR SIDE	Adjust the brightness of operator-side display. Input range: 0 to 100
VERT. / HORI.	Switch between the vertical and horizontal screen display.

5.5 SOUND

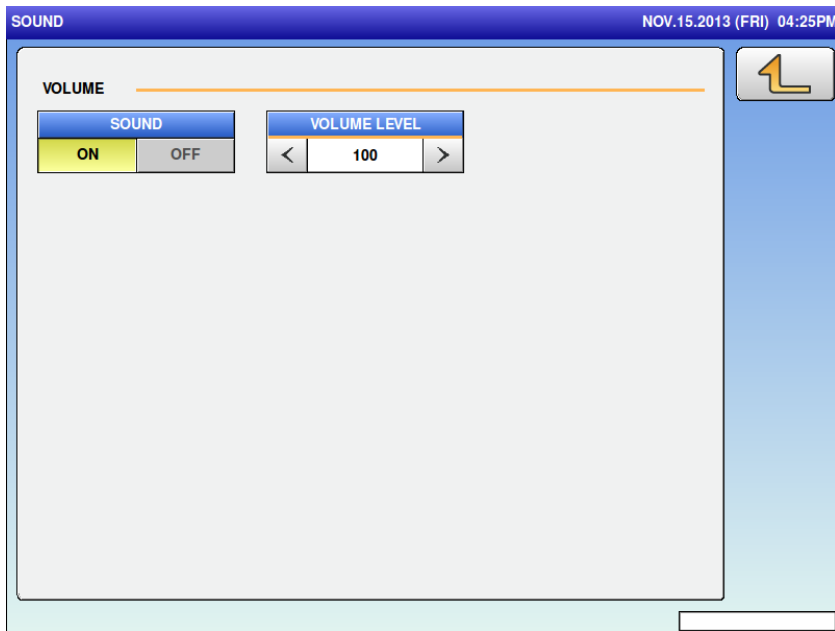

Menu name	Specification
SOUND	Switch between the sound ON and OFF.
VOLUME	Adjust the volume. Input range: 0 to 100

5.6 KEY CHECK

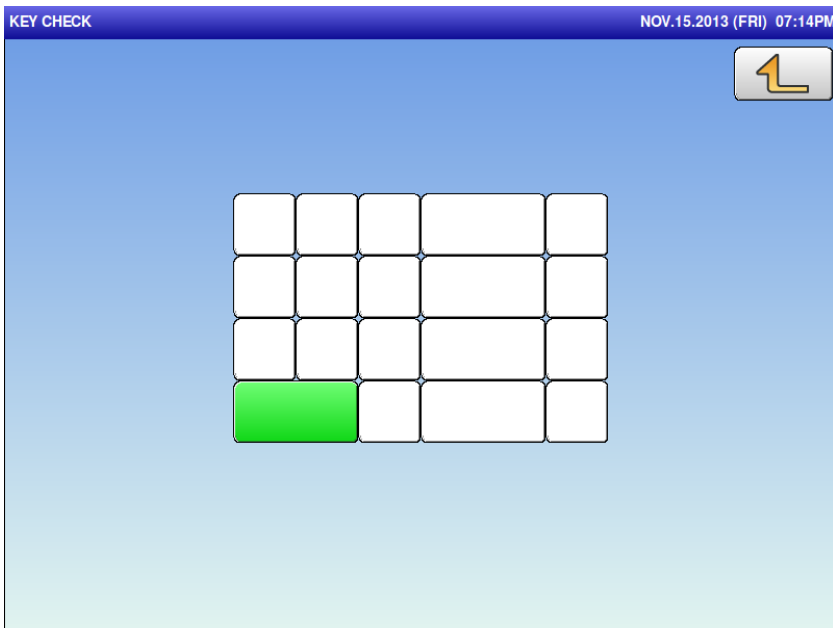

Menu name	Specification
	The touched button changes to green, showing the button is activated.

5.7 FIRMWARE DETAILS

FIRMWARE DETAILS 17-03-2014 (MON) 14:51

TITLE SOFTWARE: **Z1155-0312** LICENSE 

SOFTWARE	VERSION	SOFTWARE	VERSION
MAIN	Z1156	WRAP BOOT	Z1157RHM(J0860A)
SCALE DRIVER (UPDATER)	B0671(J0835)	CAMERA APP.(BOOT)	Z1379A(J0846)
OS	J0829E-TEST	PRINTER APP.(BOOT)	Z1158B1(J0827)
BIOS	J0825		
FPGA APP.(BOOT)	Z0979D(J0824)		
KEY BOARD	J0823A		
SCALE	J0776E		

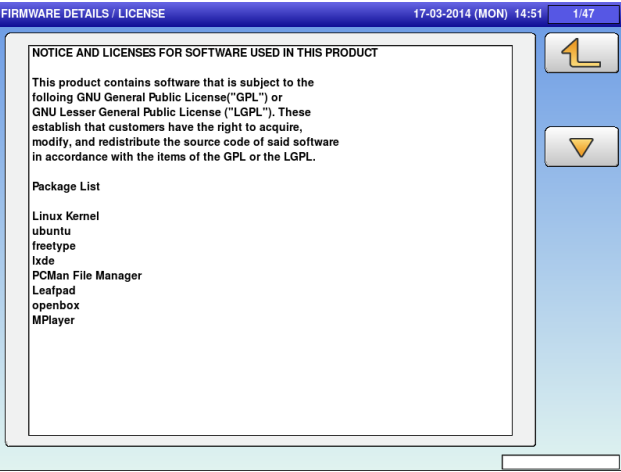
Menu name	Specification
LICENSE	<p>Move to the FIRMWARE DETAILS / LICENSE screen.</p>  <p>The screenshot shows a screen titled 'FIRMWARE DETAILS / LICENSE' with a date and time of '17-03-2014 (MON) 14:51' and a page number '1/47'. The main content area contains the following text:</p> <p>NOTICE AND LICENSES FOR SOFTWARE USED IN THIS PRODUCT</p> <p>This product contains software that is subject to the following GNU General Public License("GPL") or GNU Lesser General Public License ("LGPL"). These establish that customers have the right to acquire, modify, and redistribute the source code of said software in accordance with the items of the GPL or the LGPL.</p> <p>Package List</p> <ul style="list-style-type: none"> Linux Kernel ubuntu freetype lxde PCMan File Manager Leafpad openbox MPlayer

5.8 MEMORY CLEAR

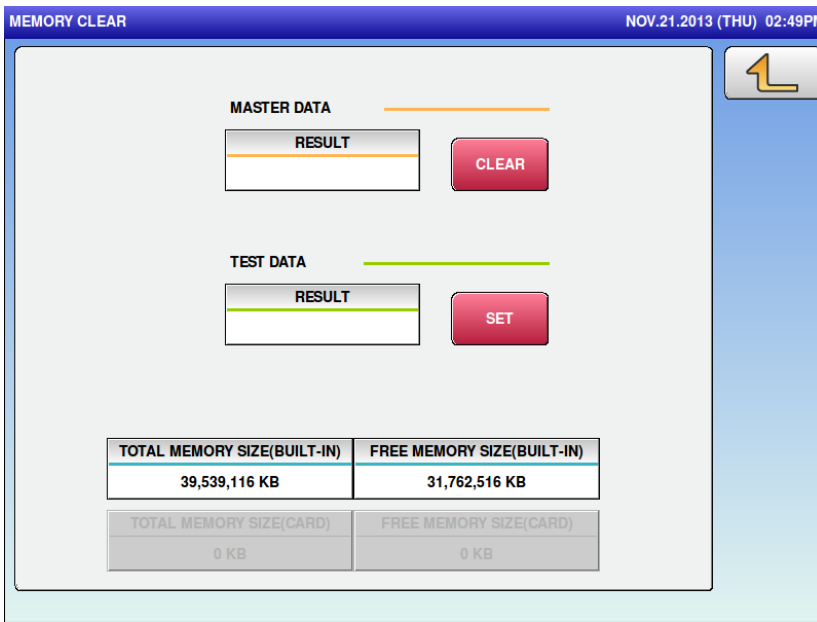

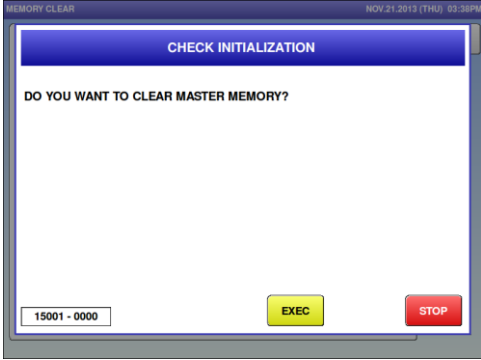
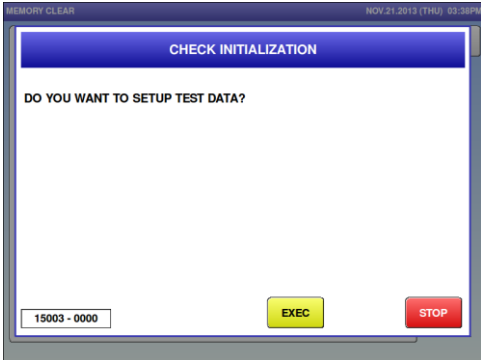
Menu name	Specification
<p>MASTER DATA CLEAR</p>	<p>Clear all DB and initialize the system master.</p> <p>The CHECK INITIALIZATION dialog (memory clear) appears to ask whether to clear the memory.</p> 
<p>TEST DATA SET</p>	<p>Set the initial data and initialize the system master.</p> <p>The CHECK INITIALIZATION dialog (test data setting) appears to ask whether to set the test data.</p> <p>For Oceanian model, the password "951753" should be entered to set the test data.</p> 

Menu name	Specification
MASTER DATA RESULT	Clear the master data and display the result. OK / ERROR
TEST DATA RESULT	Initialize the system data and display the result. OK / ERROR
TOTAL MEMORY SIZE (BUILT-IN)	Display the built-in memory size in kilobyte (kB).
FREE MEMORY SIZE (BUILT-IN)	Display the free memory size in kilobyte (kB).
TOTAL MEMORY SIZE (CARD)	Display the memory size in kilobyte (kB) when the SD card is inserted. If the SD card is not inserted, the option is grayed out.
FREE MEMORY SIZE (CARD)	Display the free memory size in kilobyte (kB) when the SD card is inserted. If the SD card is not inserted, the option is grayed out.

5.9 PRINTER

How to set the hardware for printing and label feeding is described here.

For delivery, perform the adjustment by using the labels actually in use.

To troubleshoot the failures caused by labels, use the genuine monitor labels for comparative evaluation.

5.9.1 PRINTER (HEAD)

Menu name	Specification
PRINTER	Select the printer. Only connected printer is displayed. 1: Model No.1/2: Model No.2/3: External /4: Under/5: POP
FORMAT	Set the format No. for the test print. Input range: 0 to 999 If there is no format, nothing is printed.
TEST PRINT	Select CHECKER (checkered pattern) or NORMAL (normal pattern).
TEST FORMAT(H)	Set the height of format directly. Input range: 0 to 999
BACK FEED ADJUSTMENT	Adjust the back feed for each label length. Input range: 0 to 99
HEAD USAGE	Set the head travel distance. Input range: 0 to 999

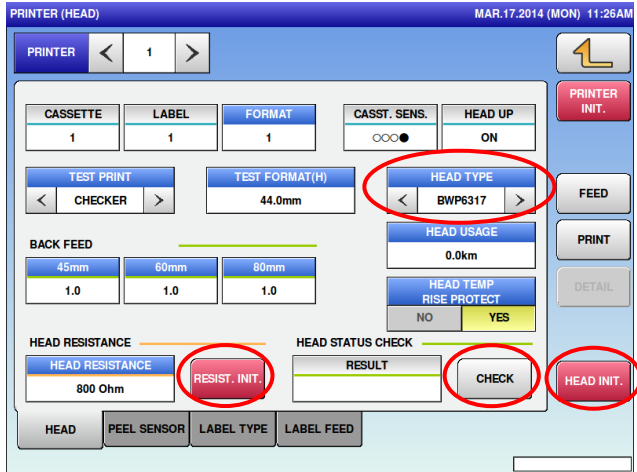
HEAD TEMP RISE PROTECT	Select whether or not to protect the head in case its temperature rises.
HEAD RESISTANCE	Set the head resistance. Input range: 0 to 9999
RESIST.INIT.	Initialize the head resistance.
PRINTER INIT.	Initialize the printer. The CHECK INITIALIZATION dialog (printer initialization) appears to ask whether to initialize the printer. Other tabs also have the same function.
PRINT	Execute the print. Other tabs also have the same function.
FEED	Execute the feed. Other tabs also have the same function.
HEAD INIT.	<p>Initialize the thermal head.</p> <p>The CHECK INITIALIZATION dialog (head initialization) appears to ask whether to initialize the thermal head.</p> <p>Follow the procedure below.</p> <ol style="list-style-type: none"> ① Press [HEAD INIT.]. ② On the confirmation screen, press [EXEC]. ③ Check HEAD TYPE on the printer to set the head type to be mounted. ④ Press [RESIST.INIT.] in HEAD RESISTANCE. ⑤ Press [CHECK] in HEAD STATUS CHECK to check the head availability.  <p>The screenshot shows the PRINTER (HEAD) menu with the following settings and buttons:</p> <ul style="list-style-type: none"> PRINTER: 1 CASSETTE: 1, LABEL: 1, FORMAT: 1 CASST. SENS.: OFF, HEAD UP: ON TEST PRINT: CHECKER TEST FORMAT(H): 44.0mm HEAD TYPE: BWP6317 BACK FEED: 45mm (1.0), 60mm (1.0), 80mm (1.0) HEAD USAGE: 0.0km HEAD TEMP RISE PROTECT: NO HEAD RESISTANCE: 800 Ohm RESIST. INIT. button HEAD STATUS CHECK: CHECK button HEAD INIT. button

5.9.2 PRINTER (PEEL SENSOR)

PRINTER (PEEL SENSOR) MAR.17.2014 (MON) 11:26AM

PRINTER < 1 >

CASSETTE	LABEL	FORMAT	CASST. SENS.	HEAD UP
1	1	1	○○○●	ON

TEST PRINT < CHECKER >

TEST FORMAT(H) 44.0mm

PEEL SENSOR LEVEL	PEEL DETECT.	PEEL SENSITIVITY
48	- 120 +	- 192 +

PRINTER INIT. FEED PRINT DETAIL HEAD INIT.

HEAD PEEL SENSOR LABEL TYPE LABEL FEED

Menu name	Specification
PEEL DETECT.	Set the threshold value of peel sensor. Input range: 0 to 255
PEEL SENSITIVITY	Set the sensitivity of peel sensor. Input range: 0 to 255
PEEL SENSOR LEVEL	Display the output value of peel sensor.
<p>Set the threshold depending on the PEEL SENSOR LEVEL at the time the backing paper remains on the sensor or not.</p> <p>(e.g. If the value at the time the backing paper remains is 180 and if the value at the time the backing paper does not remain is 80, the threshold is set to about 150.)</p>	

5.9.3 PRINTER (LABEL TYPE)

PRINTER (LABEL TYPE) MAR.17.2014 (MON) 11:26AM

PRINTER < 1 >

Menu name	Specification
LABEL TYPE	Select the label type. 0: RECEIPT / 1:130LA-1 / 3:150LA-1
PRINT DENSITY	Adjust the print density. Input range: 0 to 9
PRINT DIRECTION	Select the print direction. STAND. / INVERSE
LABEL GAP	Set the "Interval between labels" of the label roll set to the printer. Input range: 0 to 99.9
LABEL SHAPE	Set the label gap (the gap between labels). Input range: 0 to 999
ROUND LABEL	Set the correction value of irregular-shaped label. Input range: 0 to 999

5.9.4 PRINTER (LABEL FEED)

PRINTER (LABEL FEED) MAR.17.2015 (TUE) 1:41PM

PRINTER < 1 >

CASSETTE 1	LABEL 1	FORMAT 1	CASST. SENS. ○○○●	HEAD UP OFF
TEST PRINT CHECKER		TEST FORMAT(H) 37.0mm	TWIN LABEL PRINT NO YES	
SENSOR TYPE 1:LABEL		PRINT SPEED 150mm/s	BACK FEED NO YES	
LABEL SENS. DIS. 25.0mm	PRE-PRINT LENGTH 7.5mm	PRE-STOP POS. 0.0mm		
LABEL SENSOR LEVEL 255	LABEL GAP DETECT. - 0 +	SENSITIVITY - 0 +		

HEAD PEEL SENSOR LABEL TYPE LABEL FEED

PRINTER INIT. FEED PRINT DETAIL HEAD INIT.

Menu name	Specification
DETAIL	<p>Transfer to the label sensor details screen.</p> 
TWIN LABEL PRINT	<p>Set whether to perform twin label print in the test print. NO: label feed is controlled in pricing in DP mode. YES: label feed controlled on pasting label by the labelling machine.</p>
SENSOR TYPE	<p>Set the sensor type. 0: NONE / 1: LABEL / 2: MARK</p>
PRINT SPEED	<p>Set the print speed. 100 mm/s / 120 mm/s / 150 mm/s</p>
BACK FEED	<p>Select whether or not to set the back feed.</p>
LABEL SENS. DIS.	<p>Set the label sensor distance. Input range: 0 to 99.9</p>
PRE-PRINT LENGTH	<p>Set the pre-print length. Input range: 0 to 99.9</p>

Menu name	Specification
LABEL GAP DETECT.	Set the label sensor threshold. Input range: 0 to 255
SENSITIVITY	Set the label sensor sensitivity. Input range: 0 to 255
LABEL SENSOR LEVEL	Display the output value of label sensor.
Set the label sensor sensitivity so as not to exceed the peak value of label sensor. (e.g. If the label sensor peak is about 120, the threshold is set to about 100.)	

5.10 CALIBRATION

CALIBRATION APR.13.2015 (MON) 2:30PM

SETTING

CAPACITY < 30lb >	RANGE SINGLE MULTI	SPAN A/D 60000	GRAVITATIONAL ACC. 9.7970
-----------------------------	------------------------------	--------------------------	-------------------------------------

SCALE DATA

A/D 19997	CELL VOLTAGE	STATUS 0100 0001
---------------------	---------------------	----------------------------

WGT. CONVERTED

WEIGHT A/D 0	WEIGHT 0.000 lb	DATA DISPLAY WEIGHT VOLTAGE
------------------------	---------------------------	---------------------------------------

OTHERS

1083 2004 01003 003000 004001

DIP SW : 00000000

Capacity 0-15lb x 0.005lb 15-30lb x 0.01lb

Menu name	Specification
CAPACITY	Set the capacity of the scale. 6000g / 6kg / 15kg / 30kg / 30lb
RANGE	Select the range. The range to be selected is limited depending on the capacity.
GRAVITATIONAL ACC.	Set the gravitational acceleration. Input range: 97799 to 98300
DATA DISPLAY	Select the A/D or cell voltage display.
INITIAL	Initialize the scale.
ZERO	Adjust the current scale status to zero.
SPAN	Set the current scale status to CAPACITY according to the CAPACITY setting.
+	Add span value.
-	Deduct span value.

5.11 MACHINE TYPE



Menu name	Specification
AUTO SINGLE	Judge as the auto pasting single type, move to the [MACHINE TYPE / DETAIL] screen. For AS models, select this option.
AUTO DUAL	Judge as the auto pasting dual type, move to the [MACHINE TYPE / DETAIL] screen. For AT models, select this option.
NON-WRAP	Judge as the inspection unit, move to the [MACHINE TYPE / DETAIL] screen.
WRAP ONLY	Judge as the single wrapper model type, move to the [MACHINE TYPE / DETAIL] screen. For the models without printer, select this option.

5.11.1 MACHINE TYPE / DETAIL

MACHINE TYPE / DETAIL MAR.17.2014 (MON) 6:41PM

STRUCTURE **AUTO 1 TYPE** WM PRODUCT ID **0000000**

WRAPPER

STATUS OK	CENTERING NO YES	EJECTION DIR. LEFT RIGHT
TRAY DETECTION NO YES	CHANGE FILM 1 2	STOCK EJECTION DIR. BACK SIDE
VARIATION < 3:TYPE B >	NON-FILM ERROR NO YES	FILM SET POS. SEL. LEFT RIGHT

PRINTER

PRINTER 1 CONNECTION OK	OUTSIDE PRINTER NO YES	PRINT DOT RATIO 1 : 1 1 : 1.1
PRINTER 2 CONNECTION	POP PRINTER CONNECT NO YES	PRINTER 1 POS. SEL. LEFT RIGHT

SET

Menu name	Specification
WM PRODUCT ID	Set the product ID in seven digits.
CENTERING	Select and set whether to use the tray centering function.
EJECTION DIR.	Select and set the tray ejection direction. This option is displayed only when it is valid (depends on the models).
TRAY DETECTION	Select and set whether to use the tray detection function.
CHANGE FILM	Select and set the film number.
STOCK EJECTION DIR.	Select and set the ejection direction of the stock conveyor. This option is displayed only when it is valid (depends on the models).
VARIATION	Select and set the model variation.
NON-FILM ERROR	Select and set whether to display the non-film error.
FILM SET POS. SEL.	Select and set the film set position. Set according to the machine model.
OUTSIDE PRINTER	Select and set whether to connect the external printer.
PRINT DOT RATIO	Select and set the printing dot ratio.
POP PRINTER CONNECT	Select and set whether to connect the POP printer.
PRINTER 1 POS. SEL.	Specify the printer No. 1 for the dual specification.
SET	Save the setting (with confirmation message).
STRUCURE	Display the configuration selected by the previous screen [MACHINE TYPE].

Menu name	Specification
STATUS	Display the communication status with the wrapper.
PRINTER 1 CONNECTION	Display the communication status with Printer No.1.
PRINTER 2 CONNECTION	Display the communication status with Printer No.2.

5.12 DOWNLOAD

5.12.1 DOWNLOAD (MAIN)

DOWNLOAD (MAIN) 17-03-2014 (MON) 14:51 1/1

COPY METHOD SELECT

If you select [MAIN > USB], 'PROGRAM No. + MACHINE No.' Folder is Created Automatically.

USB MEMORY FOLDER	APPLI. PROG.
soft	Z1155-0210
Soft_100	C1919A
Soft_50	C1919A

Menu name	Specification
COPY METHOD SELECT	When "USB>MAIN (PRG+IMG)" is selected, the program and the image data of the selected USB memory folder are downloaded. When "USB>MAIN (ONLY PRG)" is selected, only the program of the selected USB memory folder is downloaded. The image data is not downloaded.
USB MEMORY FOLDER	Touch this button to switch the selection.
APPLI. PROG.	Touch this button to switch the selection.
EXEC	Download the selected program. The CHECK EXECUTION OF MAIN PROGRAM DOWNLOAD dialog appears to ask whether to download the program.

5.12.2 DOWNLOAD (SUB APP.)

DOWNLOAD (SUB APP.) 17-03-2014 (MON) 14:51 1/1

PROGRAM FILE NAME	SEND MACHINE NAME
Z1158B.MOT	EC
Z1157L.MOT	PACK MACHINE
Z1159A.MOT	CAMERA
FPGA_APLY_Z0979D.BIN	FPGA

[MAIN]
[USB]

MAIN SUB APP. SUB BOOT EXEC

Menu name	Specification
PROGRAM FILE NAME	Touch this button to switch the selections.
SEND MACHINE NAME	Touch this button to switch the selections.
MAIN/USB	Select where the program is downloaded from. MAIN / USB
EXEC	Download the selected program. The CHECK FOR EXECUTION OF DEVICE MACHINE PROGRAM dialog appears to ask whether to download the program.

5.12.3 DOWNLOAD (SUB BOOT)

Menu name	Specification
PROGRAM FILE NAME	Touch this button to switch the selections.
SEND MACHINE NAME	Touch this button to switch the selections.
MAIN/USB	Select where the program is downloaded from. MAIN / USB
EXEC	Download the selected program. The CHECK FOR EXECUTION OF DEVICE MACHINE PROGRAM dialog appears to ask whether to download the program.

5.13 OPTION CHECK

5.13.1 OPTION CHECK (SCANNER)

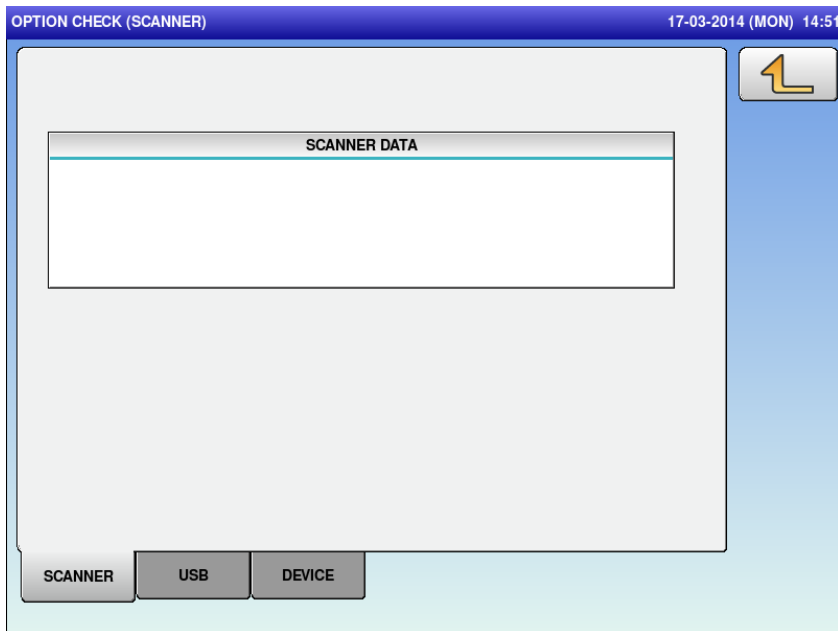

Menu name	Specification
SCANNER DATA	Display the scanned data.

5.13.2 OPTION CHECK(USB)

OPTION CHECK (USB) 17-03-2014 (MON) 14:51

USB MEMORY - 1

TOTAL MEMORY SIZE	FREE MEMORY SIZE
943,840 KB	656,128 KB

USB MEMORY - 2

TOTAL MEMORY SIZE	FREE MEMORY SIZE
0 KB	0 KB

CARD MEMORY

TOTAL MEMORY SIZE	FREE MEMORY SIZE
0 KB	0 KB

Menu name	Specification
USB MEMORY -1	Display the information of connected USB memory.
USB MEMORY -2	Display the information of connected USB memory.
CARD MEMORY	Display the information of connected SD card memory.

5.13.3 OPTION CHECK (DEVICE)

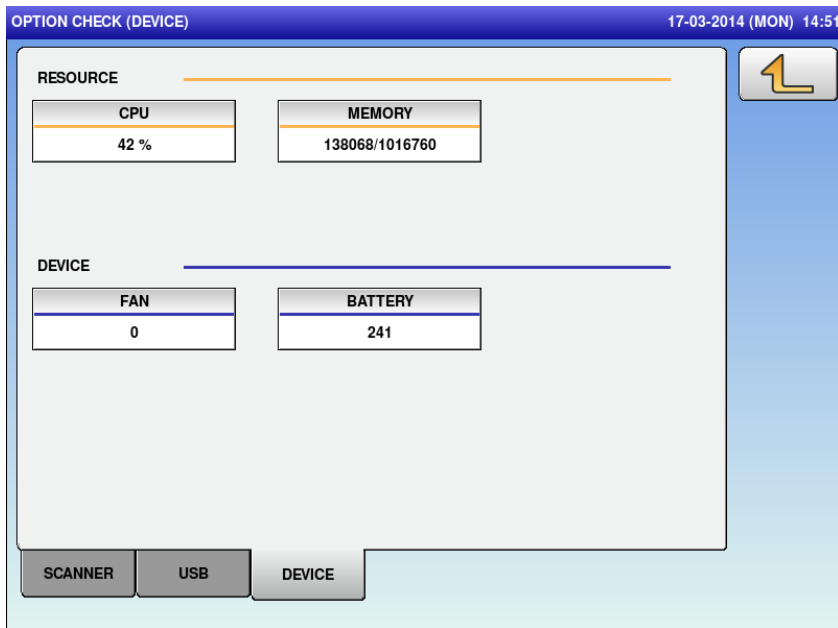

Menu name	Specification
CPU	Display the CPU use rate.
MEMORY	Display the use size and the total size of the internal memory.
FAN	Display the rotation count of the CPU fan. Unit: internal count
BATTERY	Display the battery voltage. Unit: internal AD value

5.14 WRAPPNG MACHINE

5.14.1 WRAPPNG MACHINE (FILM)

Menu name	Specification
SET UPPER FILM	When the film is replaced, prepare to use the film set above the machine.
FEED UPPER FILM	Feed the film for the length of one package from the upper film.
SET LOWER FILM	When the film is replaced, prepare to use the film set below the machine.
FEED LOWER FILM	Feed the film for the length of one package from the lower film.
RETURN	Return to the original position.
FILM MATERIAL	Select the material of the film used by the machine from "1: Vinyl chloride," "2: Poly 1," "3: Poly 2," "4: Poly 3," and "5: Vinyl chloride 3." Set the material by entering a set number. Input range: 1 to 5
(FILM CENTERING) UPPER	Adjust the stopping position of the film when feeding the upper film. Input range: -99 to 99
(FILM CENTERING) LOWER	Adjust the stopping position of the film when feeding the lower film. Input range: -99 to 99
HEATER TEMP	Set the temperature of the film welding heater. Setup range: 80 to 170°C or 176 to 339°F
(FILM LENGTH)	Adjust the length of the film when feeding the upper film.

UPPER	Input range: -99 to 99
(FILM LENGTH)	Adjust the length of the film when feeding the lower film.
LOWER	Input range: -99 to 99
TRAY SEARCH	When just packaging the tray, select when searching for the applicable tray from all the registered trays or from the trays registered in the 5-price table.
(FILM WIDTH INFO.) UPPER FILM	The width of the film set on the upper side can be configured.
(FILM WIDTH INFO.) LOWER FILM	The width of the film set on the lower side can be configured.

Note:

The amount of stretch and slide varies depending on the material or brand of the film.
The user must install the film and make adjustment.
Centering affects the wrapping condition significantly. Adjust the film to stop at the center.

■ Adjustment standard for film conveyance centering

- On the film conveyance adjustment screen, a film equivalent of 680 mm is conveyed.
- As the width from the lower clamp of the rear feeder to the right edge of the clamp cover is 680 mm evenly positioned to the wrapping center, adjust the centering and film length so that the both ends of the film come to the position shown below.

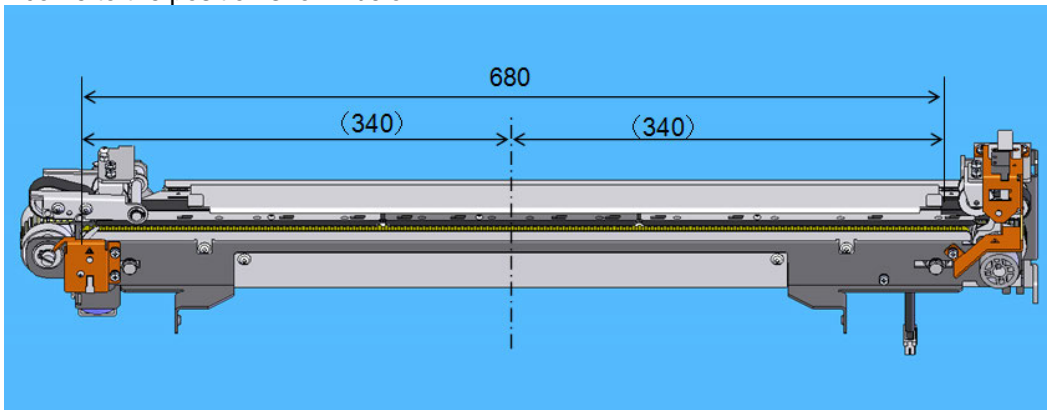

5.14.2 WRAPPING MACHINE (LIFT)

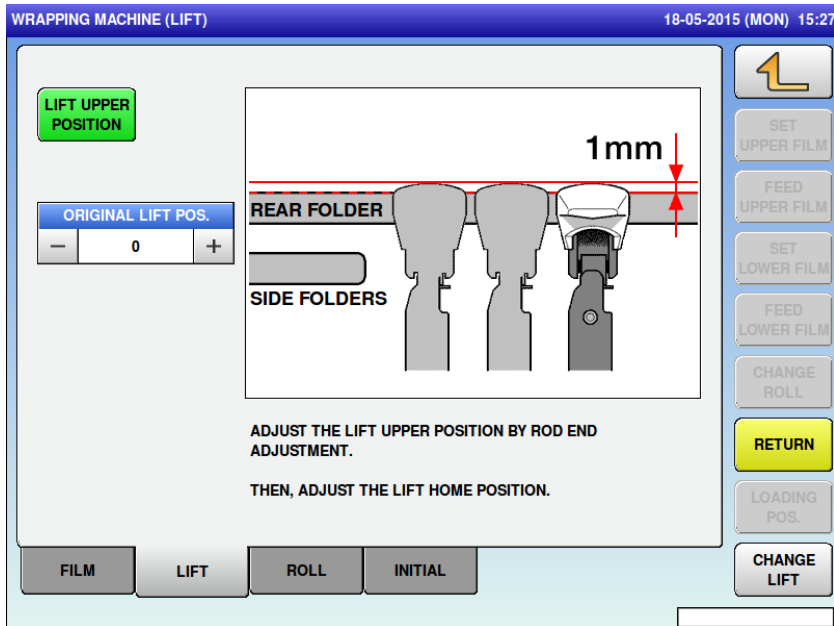

Menu name	Specification
RETURN	Return to the original position.
UPPER LIFT POS.	Raise the lift to the upper lift position.
CHANGE LIFT	After the lift is moved to the position of the lift switching height, the lift switching solenoid is turned ON/OFF repeatedly. Use this button to visually confirm from the rear of the main unit that the lift has been switched.
LIFT UPPER POSITION	Adjust the lift waiting position when supplying products. Adjust the rod end such that the top surface of the rear wrapping plate and top surface of the lift head to follow the relationship shown on the screen above.
ORIGINAL LIFT POS.	Adjust the lift waiting position when supplying products. Adjust the infeed centering conveyor surface and lift head top surface. Positive direction: Up, Negative direction: Down No numeric value input+ press "+" or "-" ... Adjust a positive or negative value by one. Numeric value input+ press "+" or "-" ... Adjust a numeric value to positive or negative by one. Numeric value input+ press other than "+" or "-" ... Adjust a numeric value to positive by one. Input range: -10 to 10

5.14.3 WRAPPING MACHINE (ROLL)

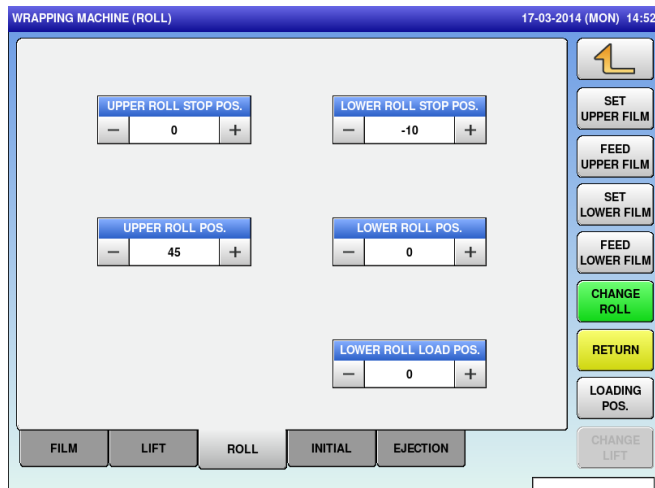

As soon as the film roll drive is stopped, the electromagnetic disk brake is turned ON to prevent the roll overrun.

Abrasion of the disk brake leads to delay in the stop timing.

In the case of an extreme overrun condition, the tension of the film between the delivery unit and roll changes rapidly from loose to tight.

As a result, the film is pulled at the pinching section, or the film run-out occurs.

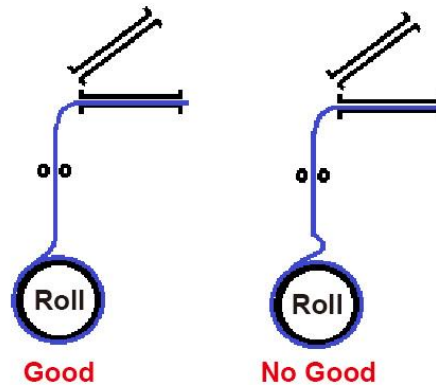

Menu name	Specification
SET UPPER FILM	When the film is replaced, prepare to use the film set above the machine.
FEED UPPER FILM	Feed the film for the length of one package from the upper film.
SET LOWER FILM	When the film is replaced, prepare to use the film set below the machine.
FEED LOWER FILM	Feed the film for the length of one package from the lower film.
CHANGE ROLL	Switch the film.
RETURN	Return to the original position.
LOADING POS.	Confirm the operation of the loading position of the lower film.
UPPER ROLL STOP POS.	Adjust the timing to stop the upper film roll. Input range: -8 to 16
UPPER ROLL POS.	Position the insert plate of the upper film.
LOWER ROLL STOP POS.	Adjust the timing to stop the lower film roll. Input range: -8 to 16
LOWER ROLL POS.	Position the insert plate of the lower film.
LOWER ROLL LOAD. POS	Set the loading position of the lower film.

Adjustment mode – Roll adjustment

[Upper roll stop position, lower roll stop position]

1. Set a new film with maximum roll diameter.
 2. Convey the film for five times and then check the film peeling position.
 3. Adjust the brake configuration for the roll to stop at a 70 to 80 degrees angle.
- * The five times conveyance contributes to the stability of the reading of the roll diameter.

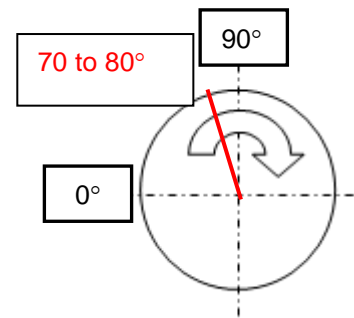

[Upper roll insertion plate position, lower roll insertion plate position]

Enter a numeric value to check the number for the plate to stop horizontally.

Check the numbers by which the gear position moves up and down from the horizontal position, and then enter the intermediate value.

- * If the insertion plate does not become horizontal, check if the insertion plate unit is positioned horizontally, adjust the supporting point mount position of the stopper rack, and then enter a numeric value.

[Lower roll insertion plate loading position]

Adjust the position in which the link lock engages and no movement occurs even if the cover is open.

It must not contact with the rubber feet.

5.14.4 WRAPPING MACHINE (INITIAL)

WRAPPING MACHINE (INITIAL) 17-03-2014 (MON) 14:52

WRAP COUNT

WRAP COUNT	WRAP PRE. COUNT	CLEAR
1050	35	

WRAPPER INIT.

RESULT	INITIAL

FILM LIFT ROLL INITIAL EJECTION

SET UPPER FILM
FEED UPPER FILM
SET LOWER FILM
FEED LOWER FILM
CHANGE ROLL
RETURN
START CONVEYOR
CHANGE LIFT

Menu name	Specification
(WRAP COUNT) CLEAR	Clear the WRAP COUNT. The WRAP PRE. COUNT is cleared by entering 495344 + CLEAR.
(WRAPPER INIT.) INITIAL	Initialize the wrapping machine. After the machine is initialized, it is necessary to set up the wrapping machine adjustment data again.

5.14.5 WRAPPING MACHINE (EJECTION)

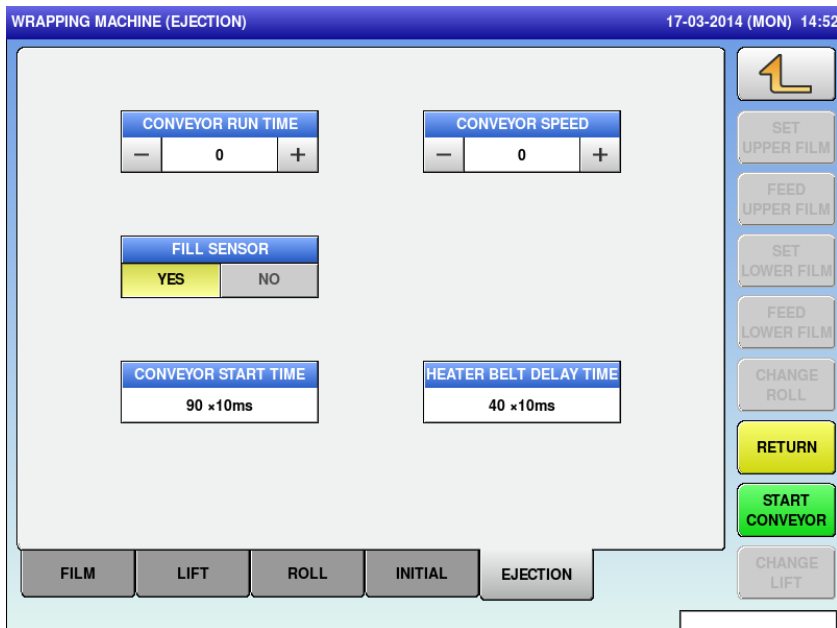

Menu name	Specification
RETURN	Return to the original position.
START CONVEYOR	Start the ejection conveyor.
CONVEYOR RUN TIME	Adjust the operating time of the ejection conveyor.
CONVEYOR SPEED	Adjust the speed of the ejection conveyor.
FILL SENSOR	Select when using the fill sensor.
CONVEYOR START TIME	Set the start time of the optional heater conveyor. *Not used when the optional heater is not connected.
HEATER BELT DELAY TIME	Set the time for the optional heater conveyor to remain stopped. *Not used when the optional heater is not connected.

5.15 CAMERA

5.15.1 CAMERA (BASIC)

Menu name	Specification
SEARCH METHOD	Select a method to obtain the tray information when the product is produced. [AUTO]: Detect the tray automatically using the camera to determine the tray information. [SELECT]: Specify which tray is used in advance.
AUTO EJECTION	Select when ejecting the thrown-in product automatically when it is packaged.
TARE	Set when using the tare of the detected tray. [TRAY]: Reflect the tray's tare after the tray is detected. [PLU]: Not reflect the tray's tare after the tray is detected. (The tare of the product when the product is called out is applied.)
TRAY SIZE LIMIT LENGTH	On the normal production screen, when entering the trays of the products to which the 5-tray search is set (automatic tray search), it is able to display a warning dialog if trays whose sizes are so similar to each other that detection error might occur are registered. So, set a range of the distance from the preset width, which is regarded as the similar size mentioned above. Input range: 0 to 99
TRAY SIZE LIMIT WIDTH	On the normal production screen, when entering the trays of the products to which the 5-tray search is set (automatic tray search), it is able to display a warning dialog if trays whose sizes are so similar to each other that detection error might occur are registered. So, set a range of the distance from the preset depth, which is regarded as the similar size mentioned above. Input range: 0 to 99
FAN/LED OFF	It is able to turn OFF the LED (illumination) of the detector and the

	<p>cooling fan automatically when work such as product call-out or production is not performed in a certain period of time.</p> <p>Set the time to turn OFF the LED (illumination) and fan in minutes after work is stopped.</p> <p>Input range: 0 to 99</p>
<p>ERROR RANGE 5 TRAY L.</p>	<p>Referred to when the 5-tray search is performed.</p> <p>Set a range of the difference between the detected width and the preset width, in which the tray can be judged as detected.</p> <p>Input range: 0 to 99</p>
<p>ERROR RANGE 5 TRAY W.</p>	<p>Referred to when the 5-tray search is performed.</p> <p>Set a range of the difference between the detected depth and the preset depth, in which the tray can be judged as detected.</p> <p>Input range: 0 to 99</p>
<p>ERROR RANGE ALL TRAY L.</p>	<p>Referred to when the all-tray search is performed.</p> <p>Set a range of the difference between the detected width and the preset width, in which the tray can be judged as detected.</p> <p>Input range: 0 to 99</p>
<p>ERROR RANGE ALL TRAY W.</p>	<p>Referred to when the all-tray search is performed.</p> <p>Set a range of the difference between the detected depth and the preset depth, in which the tray can be judged as detected.</p> <p>Input range: 0 to 99</p>
<p>AUTO EJECTION DELAY</p>	<p>On the [Normal: Production] screen, set the timing to eject the tray on the lift automatically.</p> <p>Input range: 0 to 9 When "0" is set, the tray is ejected on the current automatic ejection time, and the delay process is not performed. When "2" is set, the automatic ejection delay timer is set. The tray is ejected automatically 2.0-3.0 seconds after the tray is put on the lift.</p> <p>When the AUTO EJECTION item is set to NO, this item is grayed out and cannot be set up.</p>
<p>CENTERING</p>	<p>Set whether or not to correct the centering amount during tray conveyance.</p> <p>NO/YES (Initial value)</p>
<p>AUTO ADJ. (BRIGHT)</p>	<p>Adjust the brightness of the camera images automatically. The adjustment items are the five ones below:</p> <p>LED / CAMERA GAIN / THRESHOLD LEVEL / CONTRAST FILTER / DARK FILTER</p>
<p>AUTO ADJ. (DISTORT)</p>	<p>Adjust the distortion of the camera lens automatically. The adjustment items are the seven ones below:</p> <p>GRADIENT ADJ (OFFSET LEN, OFFSET WID)/ HEIGHT ADJ (OFFSET LEN, OFFSET WID) / TRAPEZOID ADJ. (OFFSET LEN, OFFSET WID) / ANGLE ADJ (OFFSET ANGLE)</p>

5.15.2 CAMERA (ADJUSTMENT)

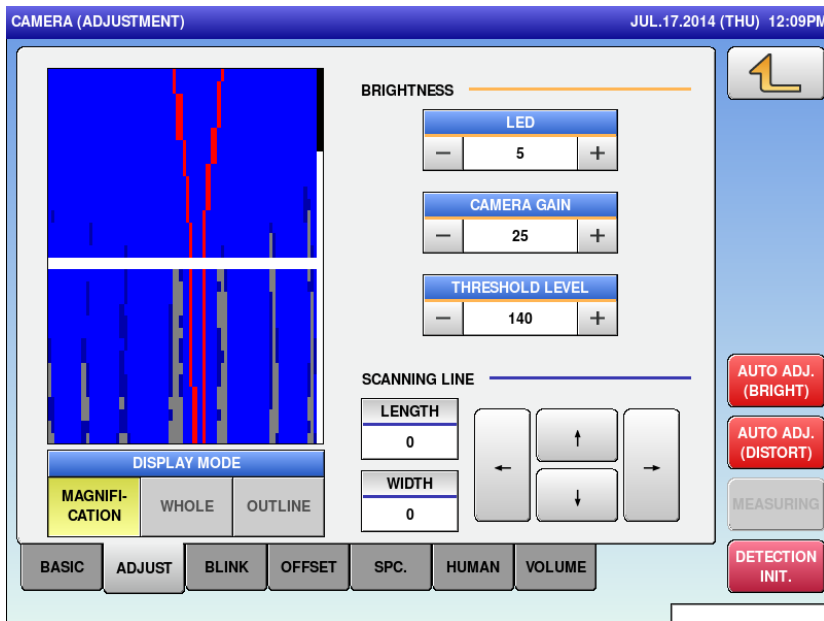

Menu name	Specification
(BRIGHTNESS) LED	Set the brightness of the LED. Input range: 0 to 15
(BRIGHTNESS) CAMERA GAIN	Set the aperture of the camera. Input range: 0 to 127
(BRIGHTNESS) THRESHOLD LEVEL	Set the reference value (threshold level) to judge if the object is a tray. Input range: 0 to 255
SCANNING LINE ←↑↓→	Correct the capturing position of the camera. If a set number is applicable, specify the set number* (-1). Otherwise, decrement the current value. The entry range is -127 to 127.
DISPLAY MODE	[MAGNIFICATION]: Magnify and display the image before conversion (imaging). [WHOLE]: Display the whole image before conversion (imaging). [OUTLINE]: Display the whole image after conversion (imaging).
DETECTION INIT.	Initialize the information on the camera.
AUTO ADJ. (BRIGHT)	Adjust the brightness of the camera images automatically. The adjustment items are the five ones below: LED / CAMERA GAIN / THRESHOLD LEVEL / CONTRAST FILTER / DARK FILTER
AUTO ADJ. (DISTORT)	Adjust the distortion of the camera lens automatically. The adjustment items are the seven ones below: GRADIENT ADJ (OFFSET LEN, OFFSET WID)/ HEIGHT ADJ (OFFSET LEN, OFFSET WID) / TRAPEZOID ADJ. (OFFSET LEN, OFFSET WID) / ANGLE ADJ (OFFSET ANGLE)

5.15.3 CAMERA (BLINK)

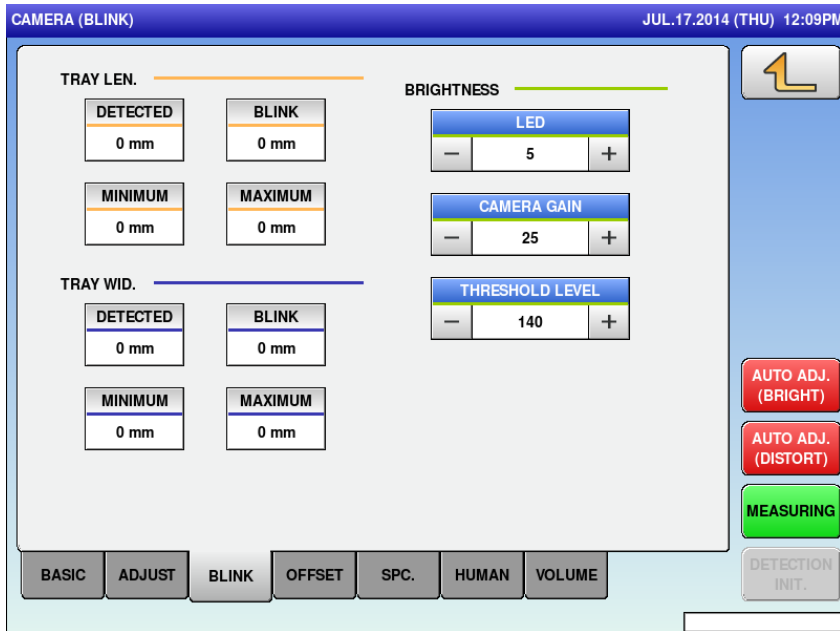

Menu name	Specification
(BRIGHTNESS) LED	Set the brightness of the LED. Input range: 0 to 15
(BRIGHTNESS) CAMERA GAIN	Set the aperture of the camera. Input range: 0 to 127
(BRIGHTNESS) THRESHOLD LEVEL	Set the reference value (threshold level) to judge if the object is a tray. Input range: 0 to 255
MEASURING	Calculate and display flickering width and depth, minimum value, and maximum value.
AUTO ADJ. (BRIGHT)	Adjust the brightness of the camera images automatically. The adjustment items are the five ones below: LED / CAMERA GAIN / THRESHOLD LEVEL / CONTRAST FILTER / DARK FILTER
AUTO ADJ. (DISTORT)	Adjust the distortion of the camera lens automatically. The adjustment items are the seven ones below: GRADIENT ADJ (OFFSET LEN, OFFSET WID)/ HEIGHT ADJ (OFFSET LEN, OFFSET WID) / TRAPEZOID ADJ. (OFFSET LEN, OFFSET WID) / ANGLE ADJ (OFFSET ANGLE)

5.15.4 CAMERA (OFFSET)

Menu name	Specification
HEIGHT SELECT	Select a height of the reference detection object (tray).
GRADIENT ADJ. OFFSET LEN.	Correction of camera gradient distortion Decrement the value if the detected size is larger when the detection object is placed to the right. Increment the value if the detected size is smaller when the detection object is placed to the right.
GRADIENT ADJ. OFFSET WID.	Correction of camera gradient distortion Decrement the value if the detected size is larger when the detection object is placed short. Increment the value if the detected size is smaller when the detection object is placed short.
HEIGHT ADJ. OFFSET LEN.	Enter the difference between the depth size of the width of the detection object and the detected depth size.
HEIGHT ADJ. OFFSET WID.	Enter the difference between the width and depth of the detected object.
TRAPEZOID ADJ. OFFSET LEN.	Correction of camera trapezoidal distortion (width direction) *Set "0" for manual adjustment. When the detection object is placed short and in the center of the weighing plate, if the difference of the detected width values is large, adjust as follows: - If the width sensed short is larger, increase the setting. - If the width in the center of the weighing plate is larger, decrease the setting.
TRAPEZOID ADJ.	Correction of camera trapezoidal distortion (depth direction)

OFFSET WID.	<p>*Set "0" for manual adjustment.</p> <p>When the detection object is placed on the left and right sides of the weighting plate, if the difference of the detected depth values is large, adjust as follows:</p> <ul style="list-style-type: none"> - If the depth on the left side is larger, increase the setting. - If the depth on the right side is larger, decrease the setting.
ANGLE ADJ. OFFSET ANGLE	<p>Rotational correction of scanning line (by rotating the scanning line in accordance with the rotational gradient of the camera).</p> <ul style="list-style-type: none"> - If rotating the scanning line CW, increment the setting. - If rotating the scanning line CCW, decrement the setting.
AUTO ADJ. (BRIGHT)	<p>Adjust the brightness of the camera images automatically. The adjustment items are the five ones below:</p> <p>LED / CAMERA GAIN / THRESHOLD LEVEL / CONTRAST FILTER / DARK FILTER</p>
AUTO ADJ. (DISTORT)	<p>Adjust the distortion of the camera lens automatically. The adjustment items are the seven ones below:</p> <p>GRADIENT ADJ (OFFSET LEN, OFFSET WID)/ HEIGHT ADJ (OFFSET LEN, OFFSET WID) / TRAPEZOID ADJ. (OFFSET LEN, OFFSET WID) / ANGLE ADJ (OFFSET ANGLE)</p>

5.15.5 CAMERA (SPC.)

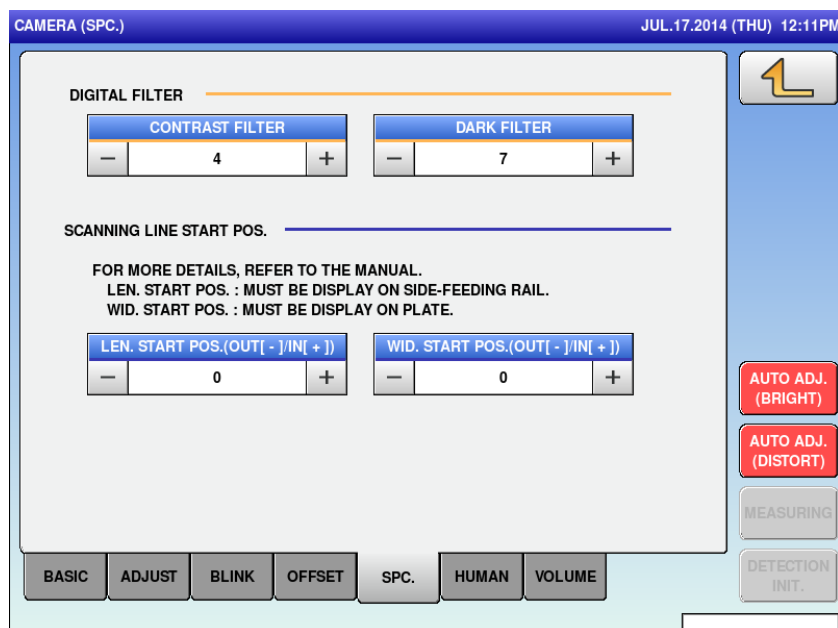

Menu name	Specification
DIGITAL FILTER CONTRAST FILTER	Adjust the judgment level of the tray by changing brightness. - Increment the value if contrast is strong on the weighing plate. - Decrement the value if contrast is weak on the weighing plate and the light-blueish tray is detected.
DIGITAL FILTER DARK FILTER	Adjust the camera exposure. - If the ambient environment is so bright that the camera image is blown out, increment the value. - If the ambient environment is so dark that the tray cannot be detected even by raising the gain, decrement the value.
LINE START POS.	Adjust the start position of the scanning line in the width direction. - If the start position is outside the supply rail, decrement the value. - If the start position is inside the supply rail, increment the value.
WID START POS.	Adjust the start position of the scanning line in the depth direction. - If the start position is outside the weighing plate, decrement the value. - If the start position is inside the weighing plate, increment the value.
AUTO ADJ. (BRIGHT)	Adjust the brightness of the camera images automatically. The adjustment items are the five ones below: LED / CAMERA GAIN / THRESHOLD LEVEL / CONTRAST FILTER / DARK FILTER
AUTO ADJ. (DISTORT)	Adjust the distortion of the camera lens automatically. The adjustment items are the seven ones below: GRADIENT ADJ (OFFSET LEN, OFFSET WID)/ HEIGHT ADJ (OFFSET LEN, OFFSET WID) / TRAPEZOID ADJ. (OFFSET LEN, OFFSET WID) / ANGLE ADJ (OFFSET ANGLE)

5.15.6 CAMERA (HUMAN)

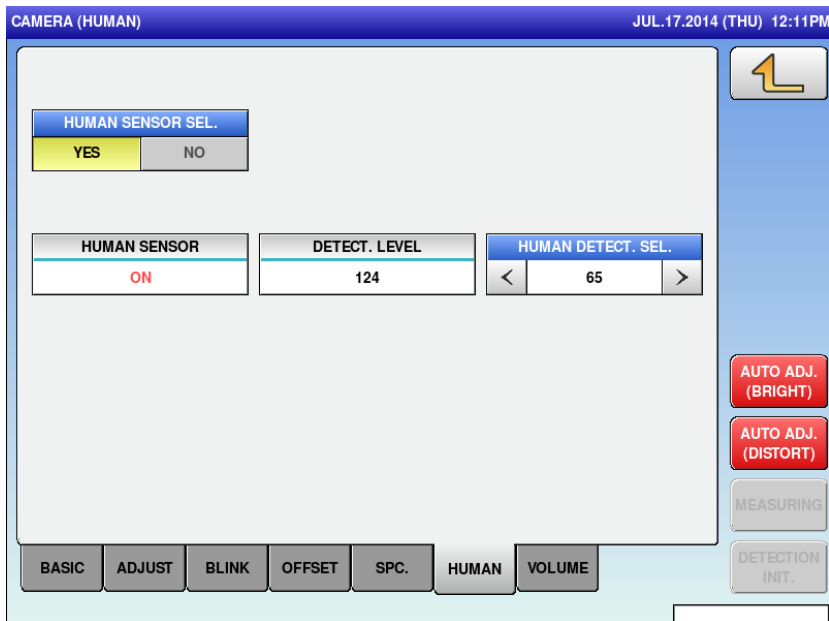

Menu name	Specification
HUMAN SENSOR SEL.	Select when using the human sensor.
HUMAN DETECT. SEL.	Set the reference value (threshold level) to judge if the sensor is sensing the presence of a person. Input range: 0 to 255
AUTO ADJ. (BRIGHT)	Adjust the brightness of the camera images automatically. The adjustment items are the five ones below: LED / CAMERA GAIN / THRESHOLD LEVEL / CONTRAST FILTER / DARK FILTER
AUTO ADJ. (DISTORT)	Adjust the distortion of the camera lens automatically. The adjustment items are the seven ones below: GRADIENT ADJ (OFFSET LEN, OFFSET WID)/ HEIGHT ADJ (OFFSET LEN, OFFSET WID) / TRAPEZOID ADJ. (OFFSET LEN, OFFSET WID) / ANGLE ADJ (OFFSET ANGLE)

5.15.7 CAMERA (VOLUME)

CAMERA (VOLUME) JUL.17.2014 (THU) 7:52PM

VOLUME

VOLUME SENSOR SEL.
 YES NO

AUTO ADJ. (VOLUME)

CALC. RESULT: 0 mm VOLUME SENSOR LEVEL: 0 VOLUME DETECT. ADJ.: < 0 >

DON'T PUT ANYTHING ON THE PLATTER.
AND ADJUST [CALC. RESULT] = 0.

AUTO ADJ. (BRIGHT)
 AUTO ADJ. (DISTORT)
 MEASURING
 DETECTION INT.

BASIC ADJUST BLINK OFFSET SPC. HUMAN VOLUME

Menu name	Specification
VOLUME SENSOR SEL.	Select when using the volume sensor.
VOLUME DETECT. ADJ.	Adjust the detection level of the volume sensor. Input range: -7 to 7 - If raising the volume, increment the setting. - If lowering the volume, decrement the setting.
AUTO ADJ. (VOLUME)	Adjust the dispersion of the sensitivity of the volume sensor.
AUTO ADJ. (BRIGHT)	Adjust the brightness of the camera images automatically. The adjustment items are the five ones below: LED / CAMERA GAIN / THRESHOLD LEVEL / CONTRAST FILTER / DARK FILTER
AUTO ADJ. (DISTORT)	Adjust the distortion of the camera lens automatically. The adjustment items are the seven ones below: GRADIENT ADJ (OFFSET LEN, OFFSET WID) / HEIGHT ADJ (OFFSET LEN, OFFSET WID) / TRAPEZOID ADJ. (OFFSET LEN, OFFSET WID) / ANGLE ADJ (OFFSET ANGLE)

5.16 LABEL APPLICATOR

5.16.1 LABEL APPLICATOR (POS.)

Menu name	Specification
RETURN	Return to the original position.
PRINTER	Select a printer or enter a set number (1 for printer No.1 and 2 for printer No.2). Only the printer being connected can be set up.
DEGREE SEL	Select a degree to paste the label when the label applicator is operated in testing.
(ADSORB POS. ADJ.) LEFT (-)/RIGHT (+) ADJ. [mm]	Adjust the position in which the label applicator adsorbs the label (in the right-left direction) when the applicator comes to the label output port of the selected printer. The adjustment range is -3 to 3 mm. (*This is -99 to 99 mm in the ROOT mode.)
(ADSORB POS. ADJ.) FRONT (-)/BACK (+) ADJ. [mm]	Adjust the position in which the label applicator adsorbs the label (in the front-back direction) when the applicator comes to the label output port of the selected printer. The adjustment range is -3 to 3 mm. (*This is -99 to 99 mm in the ROOT mode.)
(ADSORB POS. ADJ.) LEFT (-)/RIGHT (+) ADJ. [°]	Adjust the position in which the label applicator adsorbs the label (in the rotational direction) when the label applicator comes to the label output port of the selected printer. The adjustment range is -3 to 3°. (*This is -99 to 99° in the ROOT mode.)
(ADSORB POS. ADJ.) UPPER (-)/LOWER (+) ADJ. [mm]	Adjust the position in which the label applicator adsorbs the label (in the vertical direction) when the label applicator comes to the label output port of the selected printer.

(+) ADJ.	The adjustment range is -3.0 to 3.0 mm. (*This is -99.9 to 99.9 mm in the ROOT mode.)
READY TO ADSORB.	Move the label applicator to the label adsorption position in front of the label output port of the printer.
NON PRINT CHECK	The label is not issued but the label applicator operates to adsorb the label, and operates to paste the label to the tray.
PRINT CHECK	The label is issued and the label applicator adsorbs the issued label, and pastes the label to the tray.
(PASTE POS. ADJ.)	Set the position (in the width direction) in which the selected label applicator pastes the label to the tray.
LEFT (-)/RIGHT (+) ADJ. [mm]	The adjustment range is -8 to 8 mm. (*This is -99 to 99 mm in the ROOT mode.)
(PASTE POS. ADJ.)	Set the position (in the depth direction) in which the selected label applicator pastes the label to the tray.
FRONT (-)/BACK (+) ADJ. [mm]	The adjustment range is -10 to 10 mm. (*This is -99 to 99 mm in the ROOT mode.)
(PASTE POS. ADJ.)	Set the position (in the rotational direction) in which the selected label applicator pastes the label to the tray.
LEFT (-)/RIGHT (+) ADJ. [°]	The adjustment range is -5 to 5°. (*This is -90 to 90° in the ROOT mode.)
PASTE CHECK	The label is issued, and the label applicator pastes the label to the pusher.

5.16.2 LABEL APPLICATOR (ACTION)

The screenshot shows a software interface for a label applicator. At the top, it says 'LABEL APPLICATOR (ACTION)' and '19-03-2014 (WED) 13:11'. The main area contains four menu items: 'PRINTER' with a value of '1', 'SET COUNT' with a value of '0', 'COUNTER' with a value of '0', and 'DEGREE' with two options: '0 deg' (highlighted in yellow) and '-90 deg'. On the right side, there is a yellow 'RETURN' button and a green 'RUN' button. At the bottom left, there are three buttons: 'POS.', 'ACTION', and 'INIT.'. A small white box is visible at the bottom right of the interface.

Menu name	Specification
RETURN	Return to the original position.
RUN	Start continuous operation for the number of times specified on the continuous operation count item.
PRINTER	Select a printer or enter a set number (1 for printer No.1 and 2 for printer No.2). Only the printer being connected can be set up.
SET COUNT	Set the number of times of repeating the operation of issuing a label, adsorbing it, and pasting it. Specify this item by setting a number. The setup range is 0-998. If "0" is specified, this operation is repeated infinitely.
DEGREE	Select a degree to paste the label when the label applicator is operated continuously.

5.16.3 LABEL APPLICATOR (INIT.)

Menu name	Specification
(PASTE COUNT) CLEAR	Clear the number of times of the pasting operation which was performed by the label applicator.
(APPLICATOR INIT.) INITIAL	Initialize the information on the label applicator. It is necessary to adjust the information again after the applicator is initialized.
FAN OFF TIME	The adsorption fan can be turned OFF automatically when work such as product call-out or production is not performed in a certain period of time. Set the time to turn OFF the fan in minutes after the work is stopped. Specify this item by setting a number. Input range: 0 to 99
VOLUME	Set the position in which the label is pasted when the height of the product volume is small to large as the distance from the height to paste the label when the product has no volume. Input range: 0 to 99
PASTE CTRL.	Select a method to determine the pasting position in the height direction. When the paste sensor is selected, the tray is detected by the paste sensor, and the pasting position is determined. When [TRAY H.] is selected, the label is pasted in the position which is above the top surface of the ejection stand and calculated by subtracting the pasting height adjustment value from the height of the tray master.
PASTE H. ADJ.	When [PASTE CTRL.] is specified as [TRAY H.], the pasting position might be too high or low due to the size difference among the trays. So correct the position using the [PASTE H. ADJ.] item.

	Input range: -99 to 99 *This setting is referred to only when [PASTE CTRL.] is specified as [TRAY H.]
LABEL WAIT STAND	Select an option according to the mounted label wait stand.

5.17 UNIT ACTION

5.17.1 UNIT ACTION (WRAP)

UNIT ACTION (WRAP) 19-03-2014 (WED) 15:07 1/2

No.	UNIT	No.	UNIT	No.	UNIT
1	SENSOR CHECK	9	FRONT FEEDER MOVE	17	FRONT CLAMP
2	LIFT	10	REAR FEEDER MOVE	18	REAR CLAMP
3	LIFT CHANGE	11	SIDE PLATE	19	LIFT SOLENOID
4	FEED	12	BACK PLATE	20	HEATER GUARD
5	CENTERING	13	PUSHER	21	EJECT CONVEYOR
6	INSERT	14	TRAY PRESS	22	UNDER SOLENOID
7	ROLL	15	CUTTER	23	UNDER ADSB. FAN
8	FEEDER	16	PINCH	24	

ACTION No.
0

WRAP LABEL APP.

RETURN

KEY LOCK (UNLOCK)

RUN

Menu name	Specification
RETURN	Return to the original position.
KEY LOCK	Prohibit/release the execution of testing operation. In the LOCK state, only stopping is permitted.
RUN	Operate the unit of the selected number. (If this item is not selected or number zero is selected, operation is stopped.)
ACTION No.	Select a unit to operate. Specify a set number. The numbers on the unit list can be specified.
UNIT	Select a unit to operate.

5.17.2 UNIT ACTION (LABEL APP.)

UNIT ACTION (LABEL APP.) 19-03-2014 (WED) 15:07 1/1

No.	UNIT	No.	UNIT	No.	UNIT
1	APPL CONTROL SENSOR	9	FAN ROTATION	17	
2	APPL SAFETY SENSOR	10	WRAPPER(U)+APPL(1)	18	
3	LEFT AND RIGHT MOVE	11	WRAPPER(U)+APPL(2)	19	
4	BACK AND FRONT MOVE	12	WRAPPER(D)+APPL(1)	20	
5	UP AND DOWN MOVE	13	WRAPPER(D)+APPL(2)	21	
6	AXIS DIRECTION MOVE	14		22	
7	APPL(1) ALL	15		23	
8	APPL(2) ALL	16		24	

ACTION No.
0

WRAP LABEL APP.

RETURN

KEY LOCK (UNLOCK)

RUN

Menu name	Specification
RETURN	Return to the original position.
KEY LOCK	Prohibit/release the execution of testing operation. In the LOCK state, only stopping is permitted.
RUN	Operate the unit of the selected number. (If this item is not selected or number zero is selected, operation is stopped.)
ACTION No.	Select a unit to operate. Specify a set number. The numbers on the unit list can be specified.
UNIT	Select a unit to operate.

5.18 DISPLAY CAPTURE



Menu name	Specification
DISPLAY CAPTURE	<p>Select display capturing.</p> <p>At power ON, [NO] is selected as a default setting.</p> <p>Selecting [YES] displays the camera mark at the lower left side of the screen. Pressing the camera mark on each screen captures the screen, and creates the PNG file. The data is stored in the Capture folder in the USB memory.</p> <p>The PNG file name is created in series with the name from "000_xxxx.jpg" to "999_xxxx.jpg" (xxxx refers to the screen name). When a file already has the same name, the file is overwritten. The data is reset when the power is ON, and is created again from the name "000_xxxx.jpg".</p>

5.19 GRAVITY

GRAVITY NOV.21.2013 (THU) 01:55PM

SETTING

CAPACITY	RANGE	SPAN A/D	GRAVITATIONAL ACC.
15kg	MULTI	75000	9.8066

SCALE DATA

A/D	STATUS
20000	0101 0001

WGT. CONVERTED

WEIGHT A/D	WEIGHT
0	0.000 kg

OTHERS

DIP SW : 00000000

ZERO

Capacity 0- 6kg x 0.002kg 6-15kg x 0.005kg

Menu name	Specification
CAPACITY	Display the capacity.
RANGE	Display the range type.
GRAVITATIONAL ACC.	Set the gravitational acceleration. Setting range: 97799 to 98300
SPAN A/D	Display the span count.
A/D	Display the A/D count.
STSTATUS	Display the scale status.
WEIGHT A/D	Display the A/D count for weight conversion.
WEIGHT	Display the weight.
DIP SW	Display the DIP SW status of the scale.
ZERO	Display the zero-point adjustment.

Chapter 6 Trouble Shooting



INFORMATION

The latest trouble shooting is on the FullWEB. For details, please refer [WM-AI Trouble Shooting] on the FullWEB.

6.1 Operation as IP (scale and printer)

This section describes how to temporarily use the wrapper as IP (scale and printer only available) when the machine cannot be used as intended due to an error, etc.

- 1 Turn off the power of the wrapper.
- 2 Apply the power to the wrapper. The following screen 1 appears.
- 3 Press the emergency stop switch of the wrapper.
- 4 Press the [RETURN] button of the wrapper 11 times. The screen 1 disappears and changes to the regular screen.
- 5 After opening the front cover, the wrapper can be used as IP (scale price labeler).

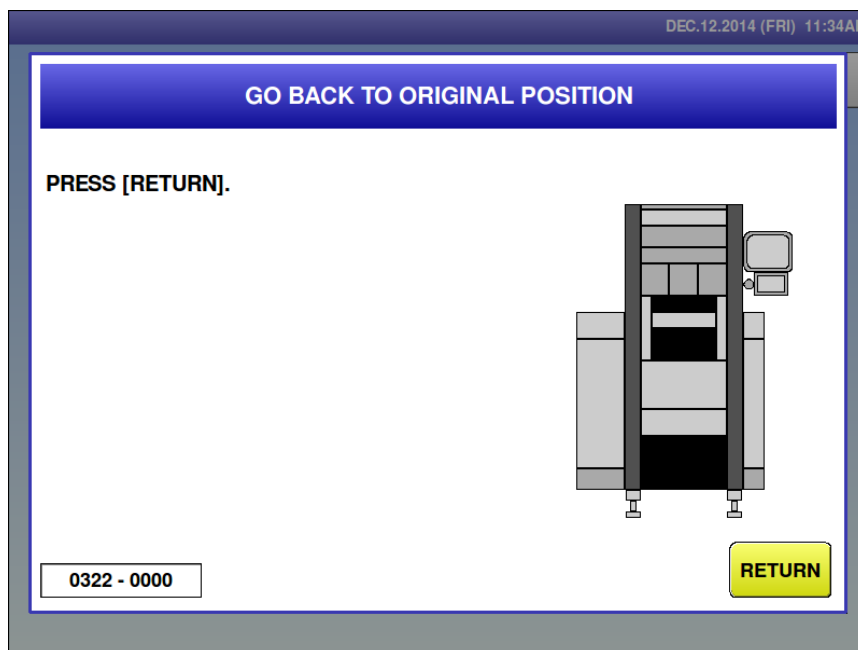

Screen 1: When power-on

6.2 Error Message

6.2.1 Error Screen

When the machine detects an error, the following error message and error No. are displayed. Some errors can be recovered simply by pressing corresponding buttons.

Some require combination of the button and simple operations, or maintenances such as replacing parts.

Be sure to check an error No. when you receive an inquiry from a user.

Even error messages are similar, different solution may be necessary to clear the errors.

Error No. consists of main No. (4 digits) + Sub-No. (4 digits).

If only a type of sub-No. (0000) exists, an error message list displays main No. only.

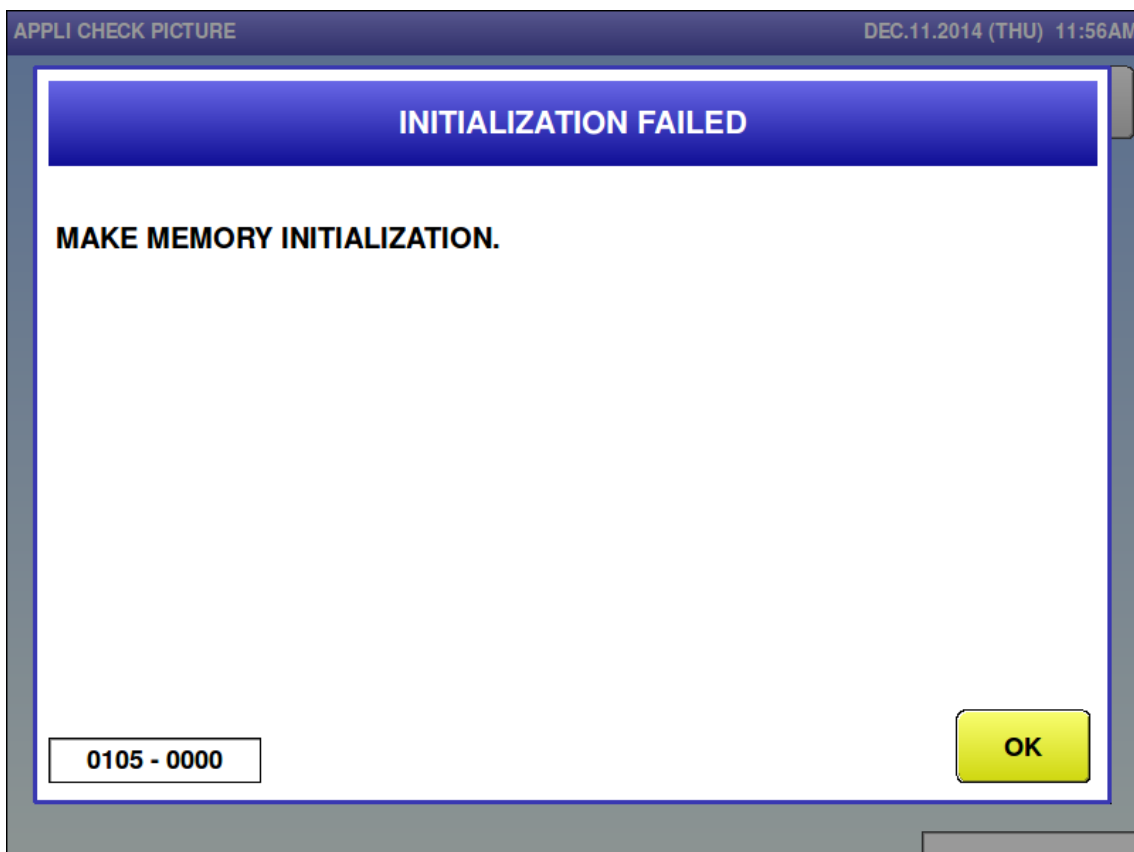

Screen 2: Example of error screen

6.3 System Error

6.3.1 System-related Error (No. 100s)

- Initialization failed (0105)

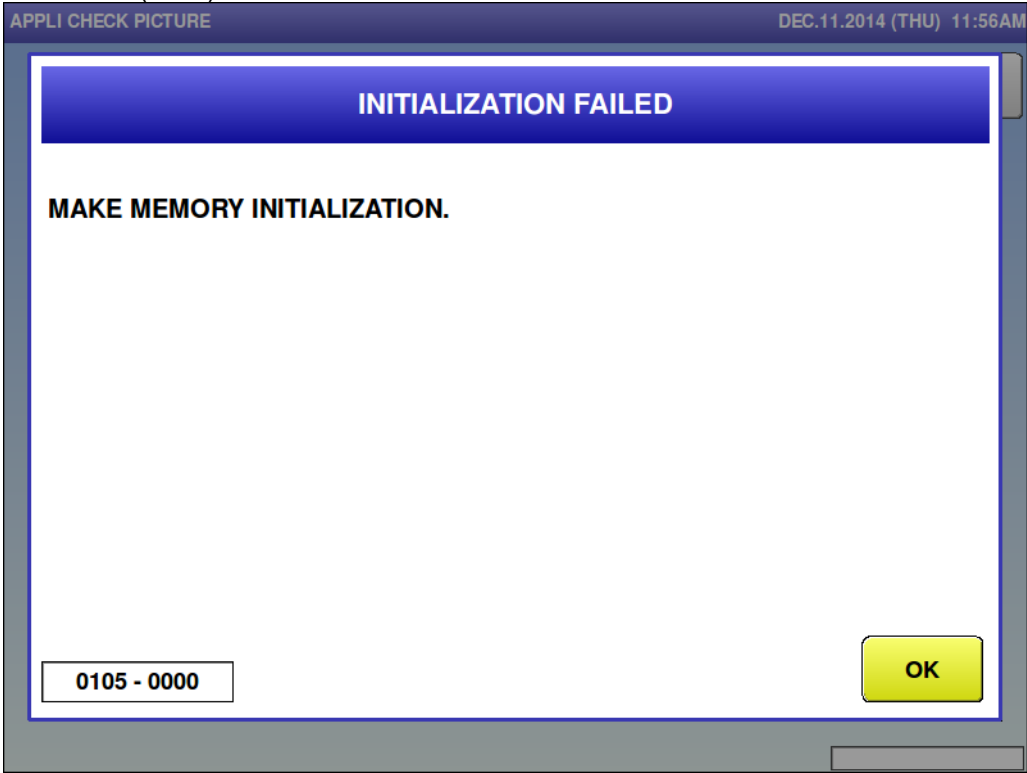

Error content	Initialization failed.
Detail	Initialization has not been performed.
Solution	[OK] button
Action by user	
Action by service representative	Perform memory initialization.
Related part	Main board
Remarks	Memory needs to be cleared on the [ADJUST (MEMORY CLEAR)] screen.

■ Battery is faulty (0106)

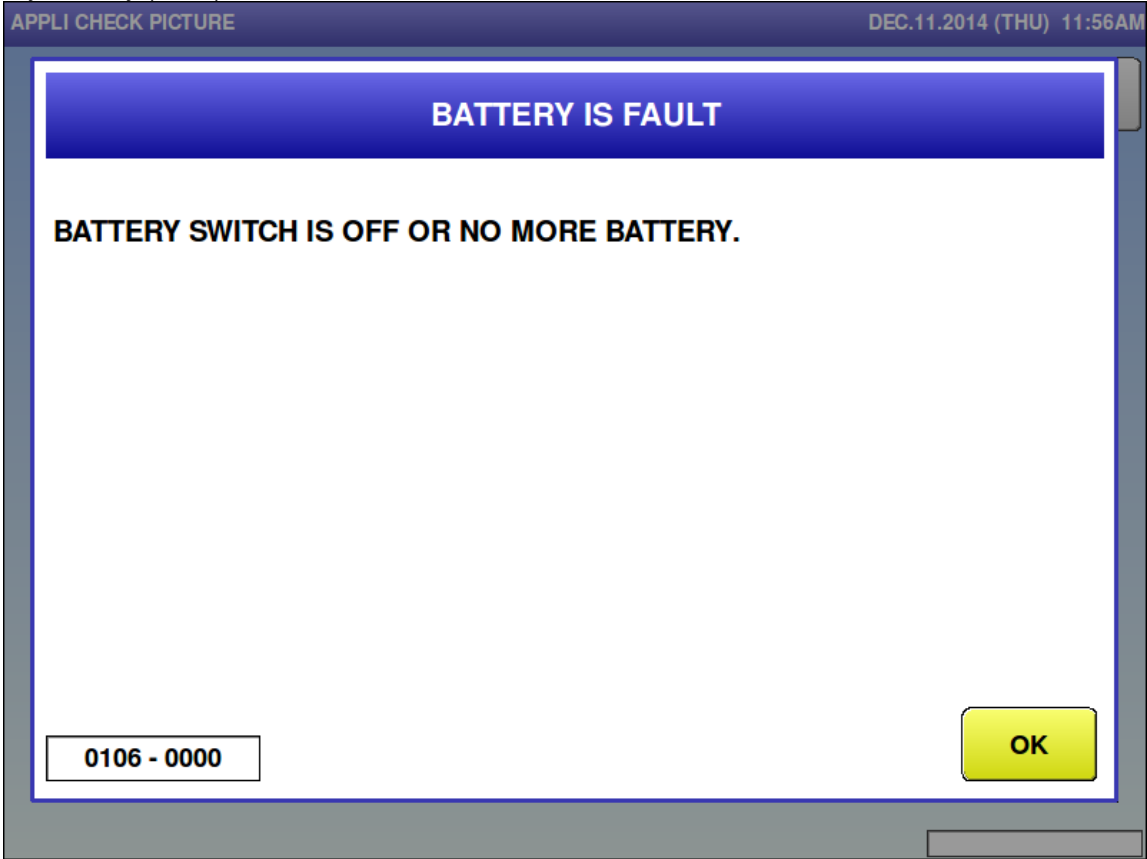

Error content	Battery is faulty.
Detail	Battery in the board is exhausted.
Solution	[OK] button
Action by user	
Action by service representative	Check the battery of the main board. Check the battery switch of the main board.
Related part	Main board
Remarks	Turn off the machine and replace the battery in the board. Confirm the battery switch.

- Touch screen adjustment is not completed yet (0107)

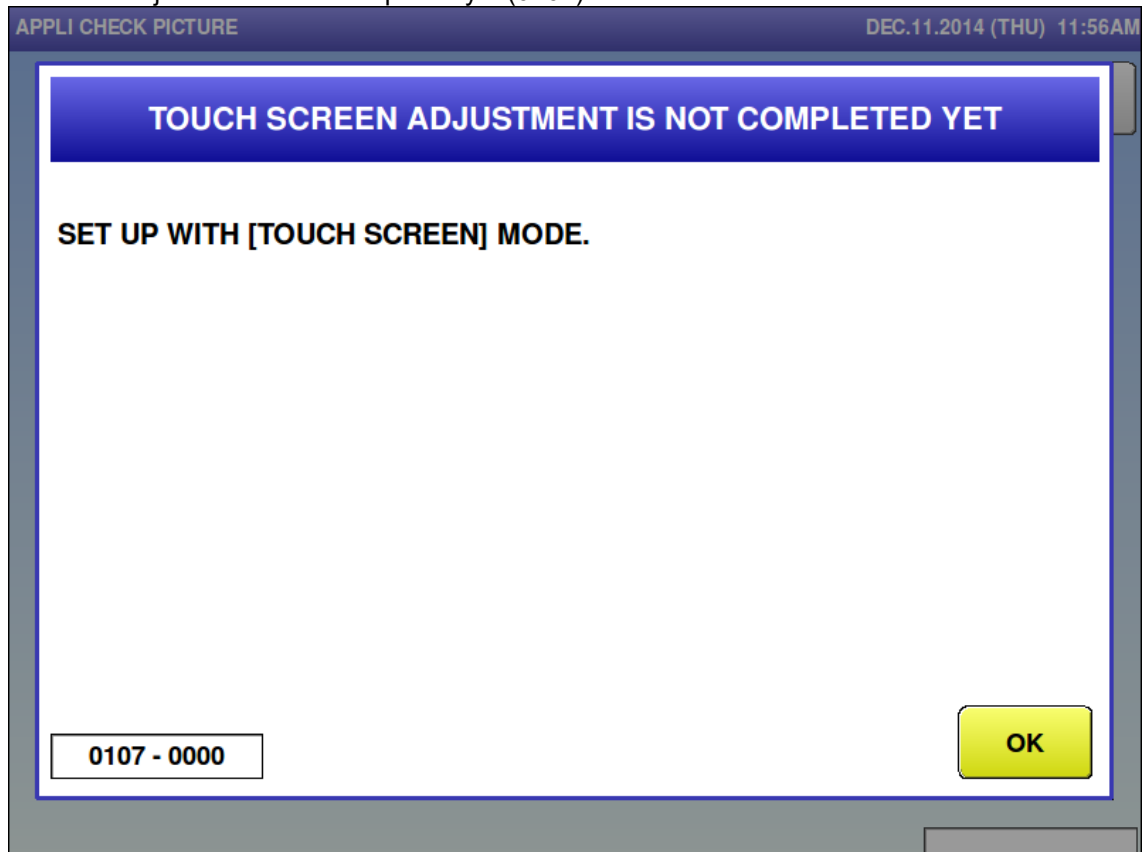

Error content	Touch screen adjustment is not completed yet.
Detail	
Solution	[OK] button
Action by user	Perform touch panel adjustment.
Action by service representative	Perform touch panel adjustment.
Related part	Main board Display board
Remarks	Set up on the [ADJUST (TOUCH SCREEN)] screen.

■ Clock setting is not completed yet (0108)

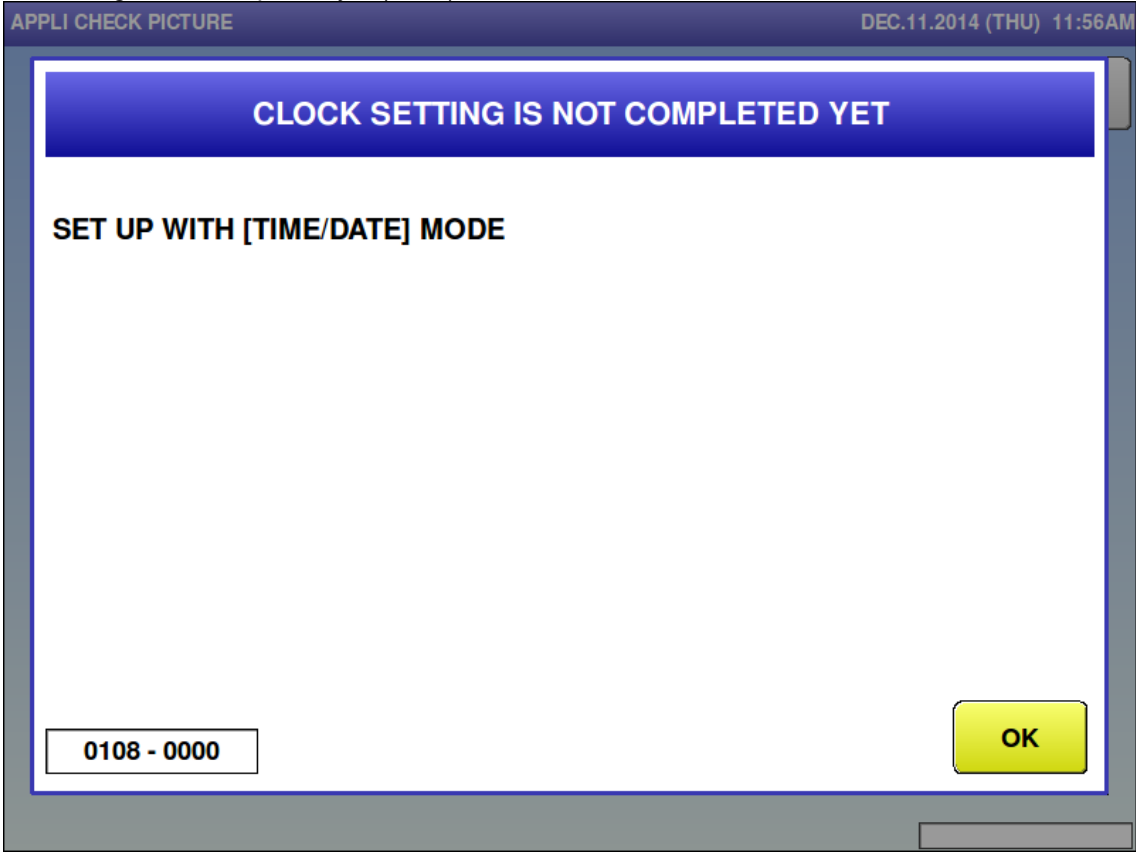

Error content	Clock setting is not completed yet.
Detail	
Solution	[OK] button
Action by user	Perform date adjustment.
Action by service representative	Perform date adjustment.
Related part	Main board
Remarks	Set up on the [ADJUST (DATE TIME)] screen.

■ Printer 1 initialization was not done yet (0109)

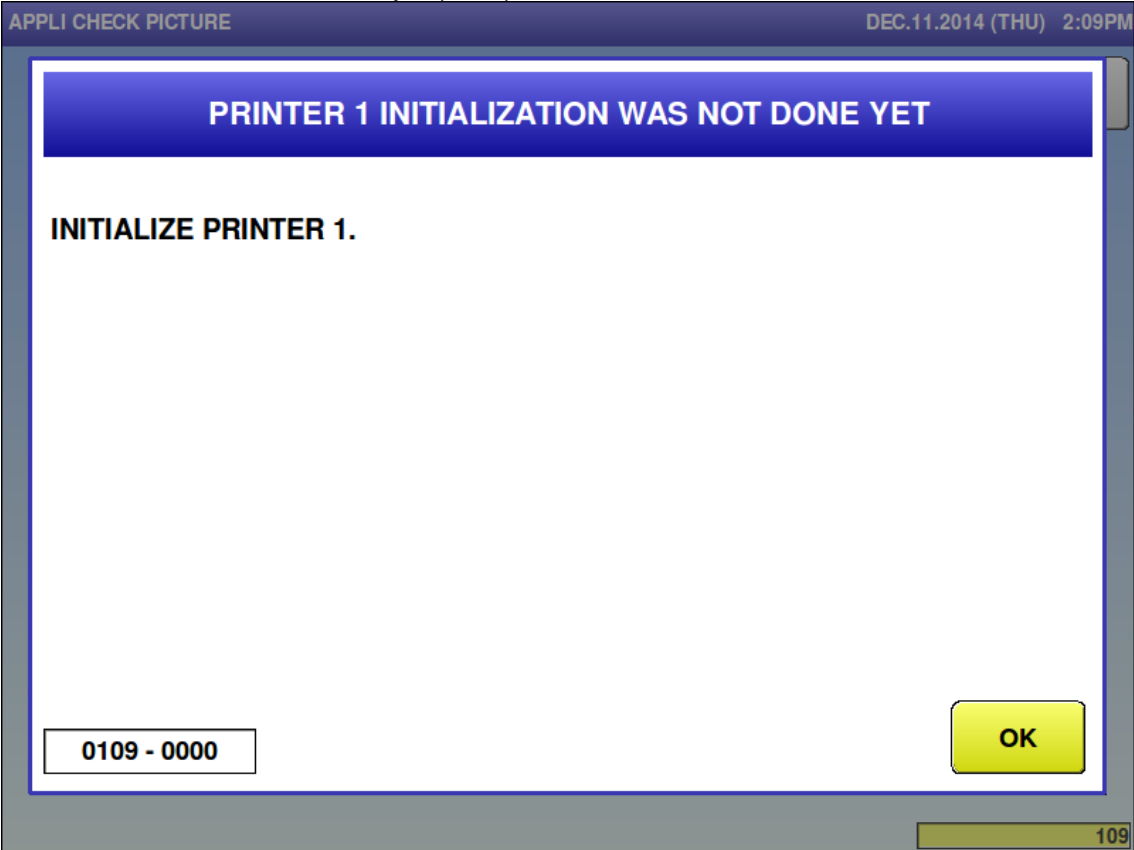

Error content	Printer 1 initialization was not done yet.
Detail	Sub-error is the printer number. 0000: Printer No.1 0001: Printer No.2
Solution	[OK] button
Action by user	
Action by service representative	Perform printer initialization.
Related part	Main board
Remarks	The title of "Printer No.1" depends on sub error No. Perform printer initialization on the [ADJUST (PRINTER)] screen.

■ Machine setting is not completed (0110)

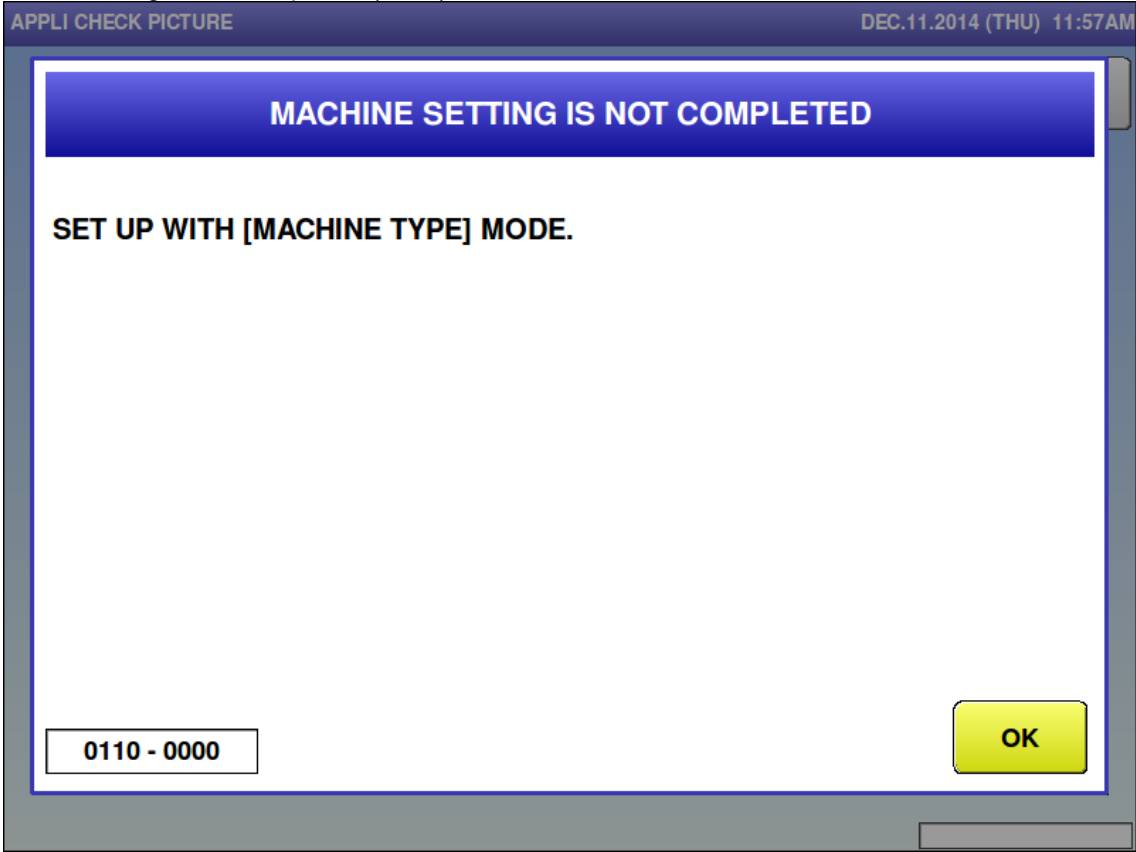

Error content	Machine setting is not completed.
Detail	
Solution	[OK] button
Action by user	
Action by service representative	Perform machine type settings.
Related part	Main board
Remarks	Set up on the [ADJUST (MACHINE TYPE)] screen.

- The display confirmation is not completed (0111)

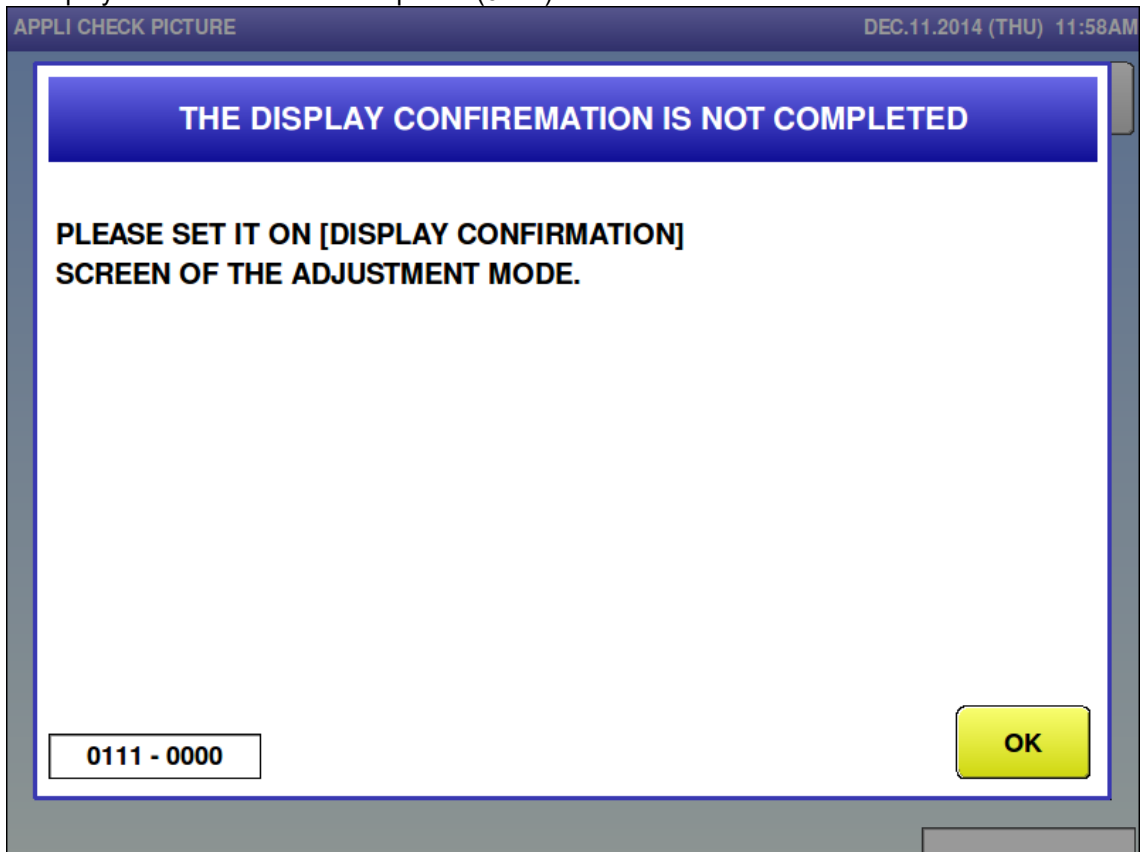

Error content	The display confirmation is not completed.
Detail	
Solution	[OK] button
Action by user	
Action by service representative	Perform display settings.
Related part	Main board
Remarks	Set the brightness on the [ADJUST (DISPLAY CHECK)] screen.

- Confirm operation of the tactile keyboard (0112)

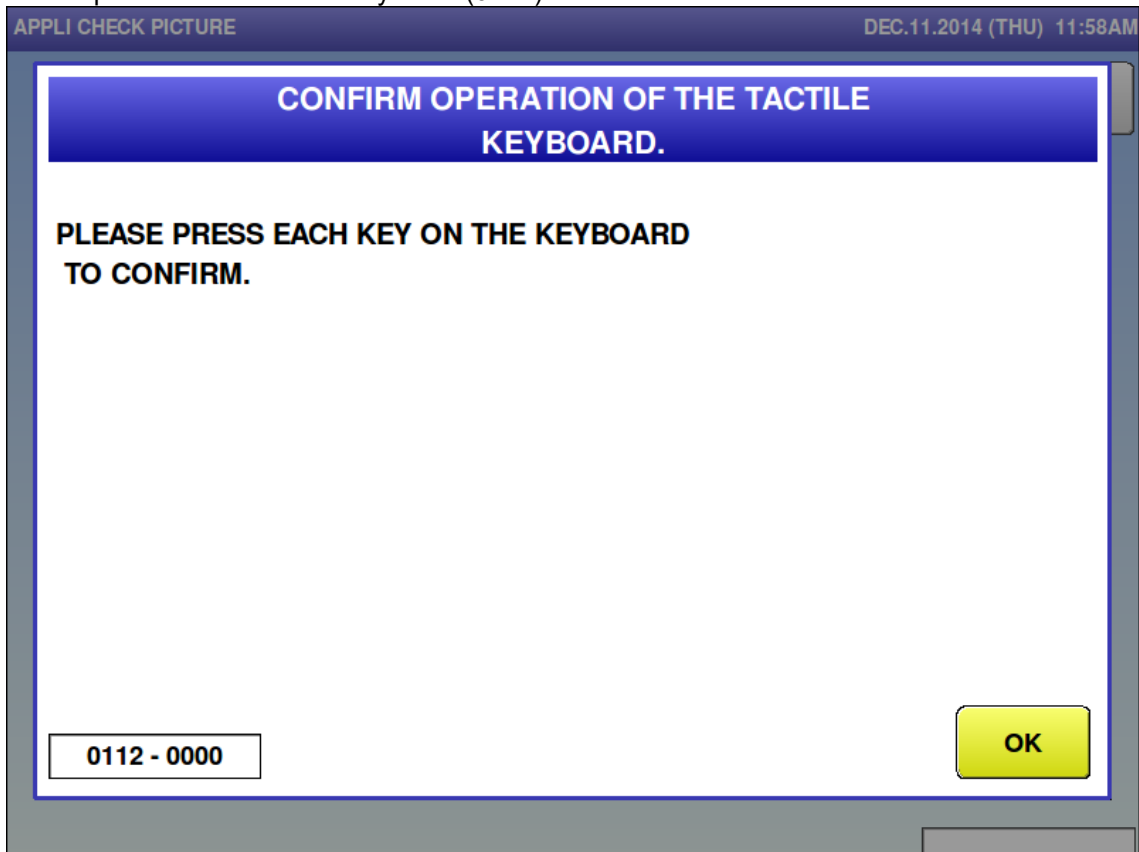

Error content	Confirm operation of the tactile keyboard
Detail	
Solution	[OK] button
Action by user	
Action by service representative	Confirm the key operation.
Related part	Main board Display key board
Remarks	Check the key on the [ADJUST (KEY CHECK)] screen.

■ Data composition is different (0114)

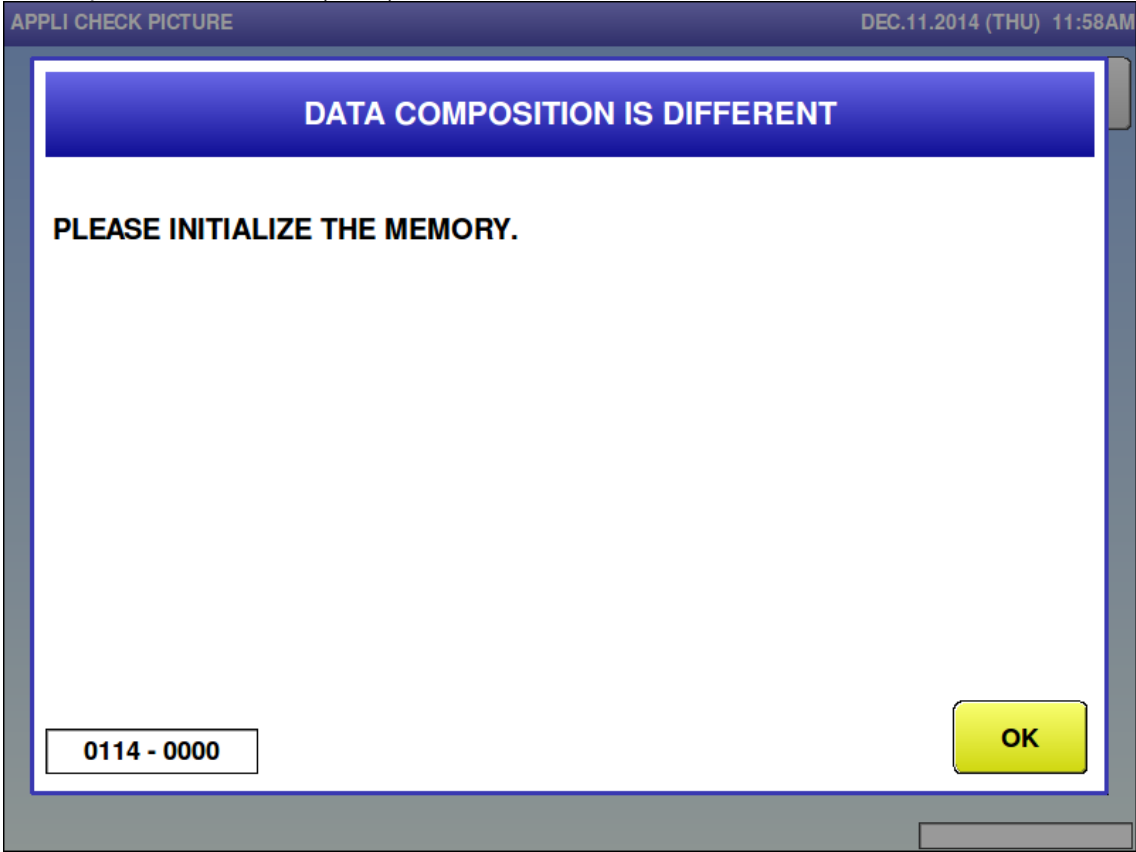

Error content	Data composition is different.
Detail	Data composition of data base is different
Solution	[OK] button
Action by user	
Action by service representative	Master return after memory initialization
Related part	Main board
Remarks	Data composition is different. Change is made to data composition.

- The country has not been selected (0118-0000)



Error content	Confirm country selection.
Detail	Country is not selected.
Solution	[OK] button
Action by user	
Action by service representative	Select a country.
Related part	Main board
Remarks	

■ FAN is abnormal. (0121-0000)

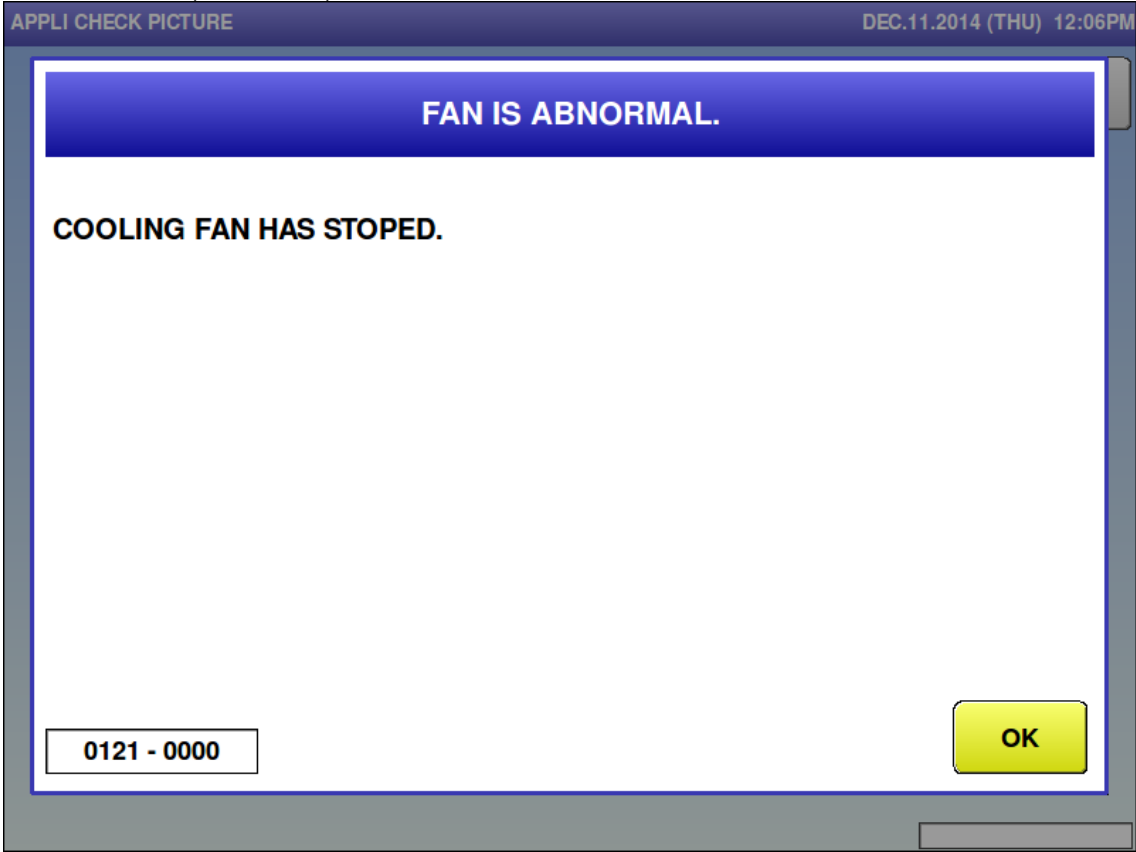

Error content	FAN error
Detail	
Solution	[OK] button
Action by user	
Action by service representative	Check the connection between the main board and fan. Check the fan.
Related part	Main board CPU-FAN
Remarks	

6.3.2 Memory-related Error (No. 200s)

- PLU master is not programmed (0202)

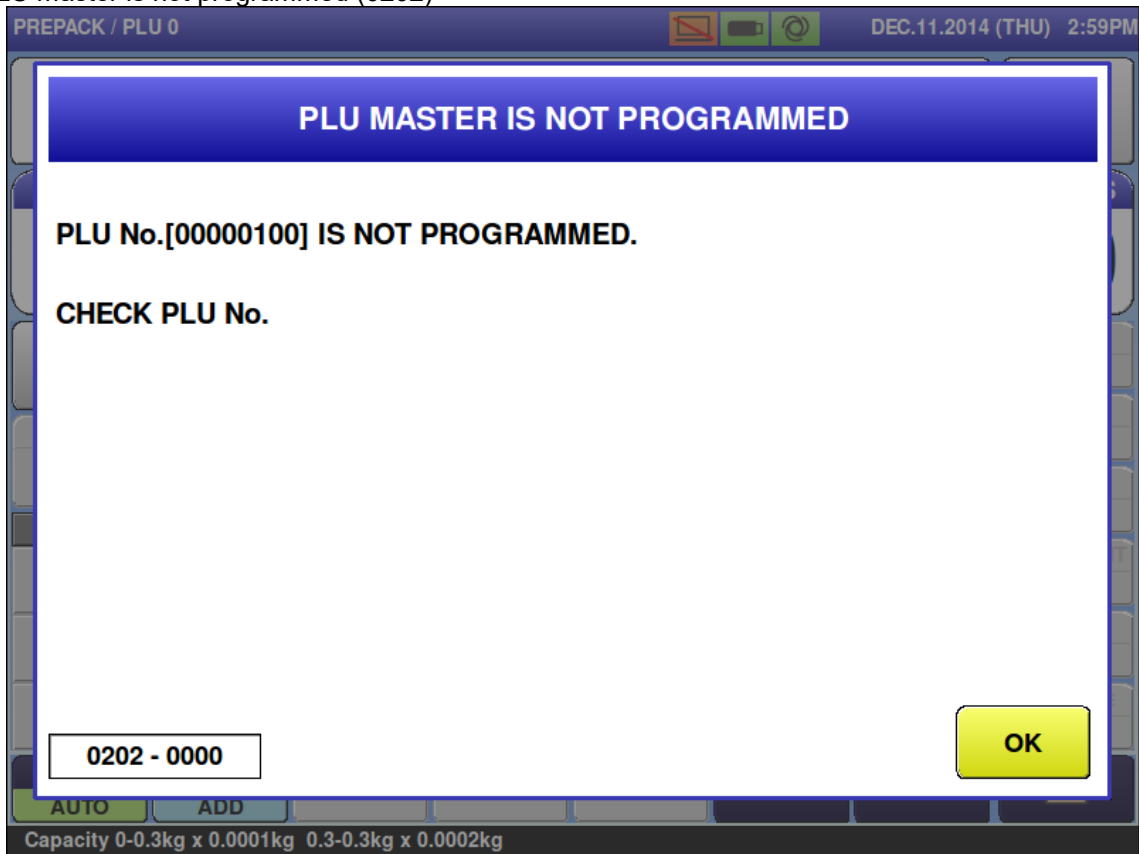

Error content	PLU master is not programmed
Detail	Does not exist in internal master.
Solution	[OK] button
Action by user	Reconfirm the PLU No. Add the product master.
Action by service representative	Confirm the master. Setting mode (Production): Confirm the auto product deletion setting.
Related part	Main board
Remarks	The product number is displayed.

■ POP master is not programmed (0203)

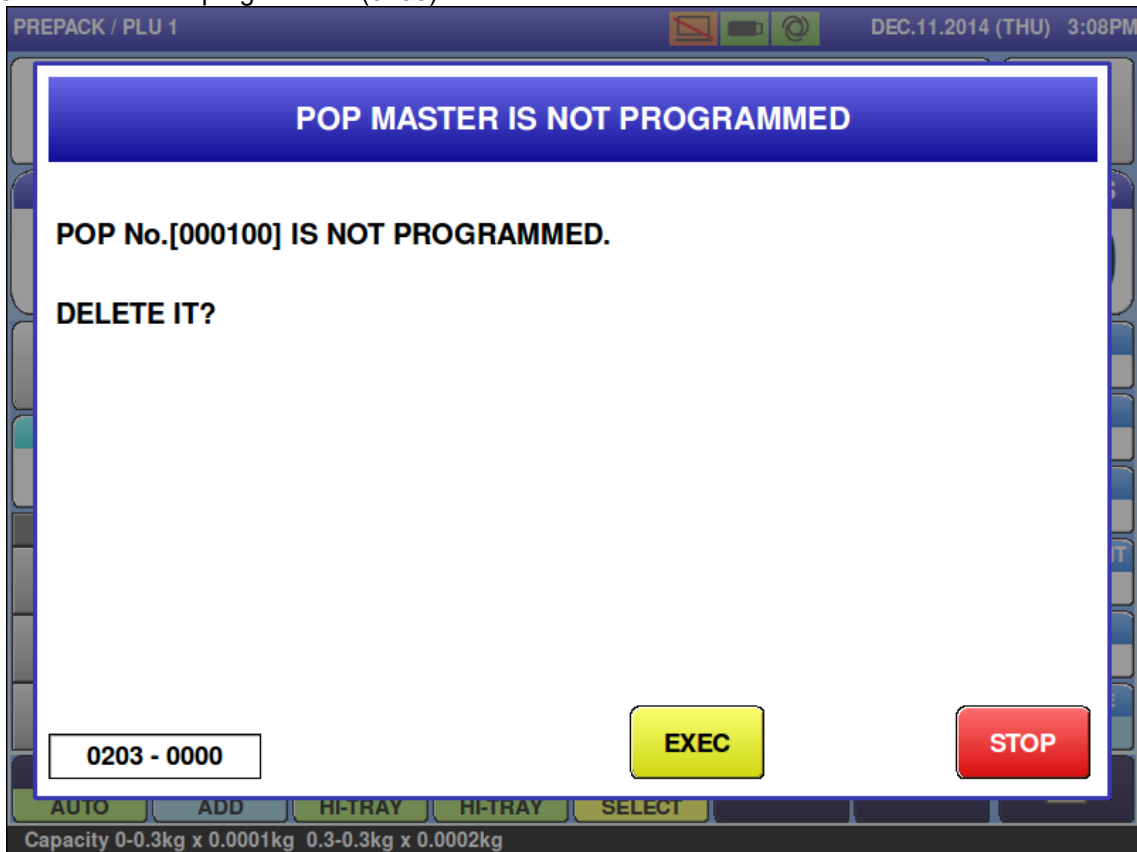

Error content	POP master is not programmed.
Detail	Does not exist in internal master.
Solution	[EXEC] button => Delete Product Master POP No. [STOP] button => Cancel error.
Action by user	Reconfirm the POP number. Add the POP master.
Action by service representative	Confirm the master.
Related part	Main board
Remarks	The POP No. is displayed. In the case of no automatic POP No. update, product master is not changed. Error screen can be changed in link master error settings.

- Tray master is not programmed (0210)

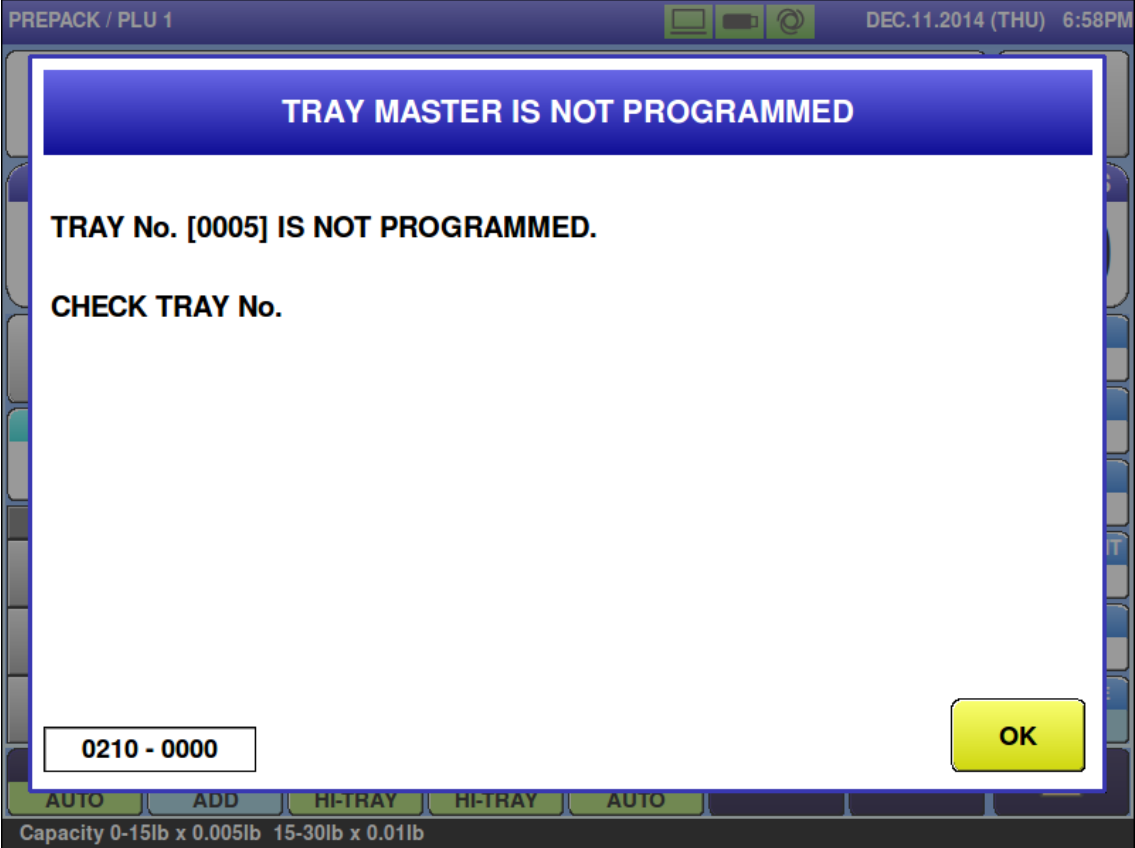

Error content	Tray master is not programmed.
Detail	Does not exist in internal master.
Solution	[OK] button
Action by user	Reconfirm the tray master number. Add the tray master.
Action by service representative	Confirm the master.
Related part	Main board
Remarks	Tray master No. is registered.

■ Free 1 master is not registered (0212)

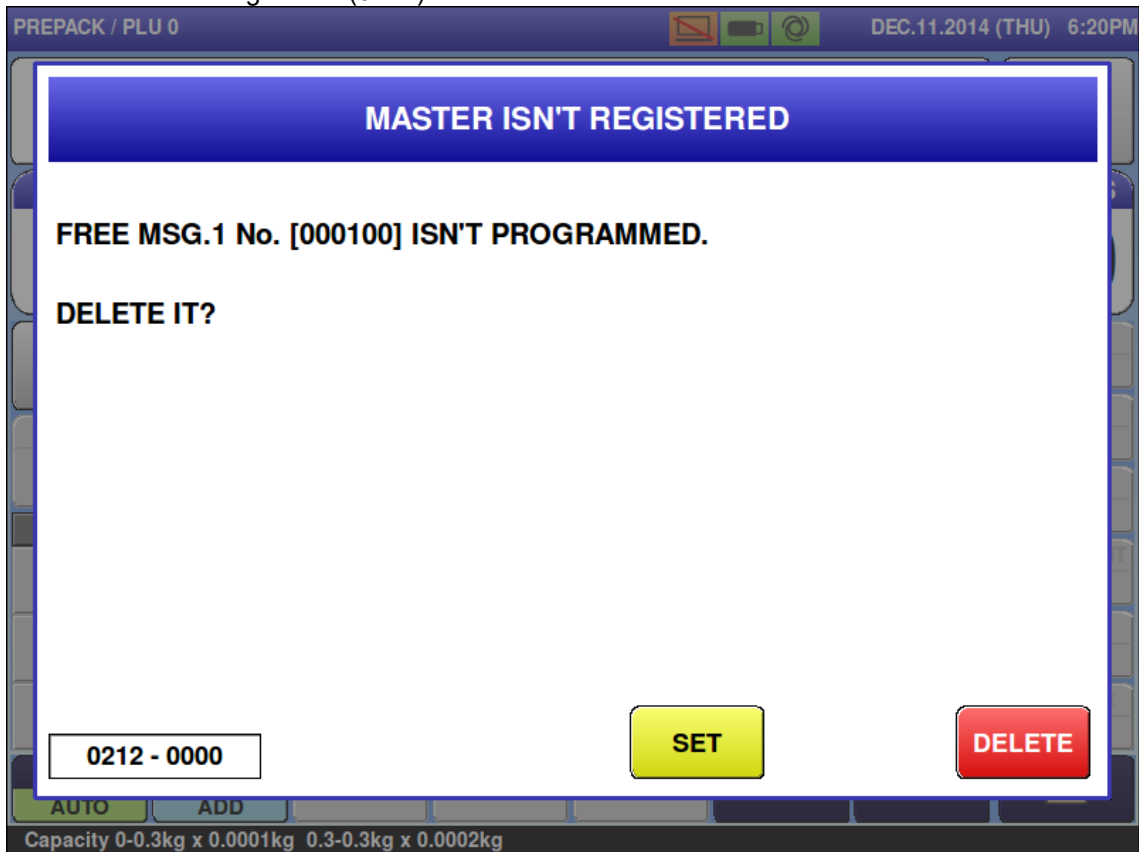

Error content	Free 1 master is not registered.
Detail	Does not exist in internal master.
Solution	[DELETE] button => Delete free No.1 of product master. [SET] button => Cancel error.
Action by user	Reconfirm the free 1 master number. Add free 1 master.
Action by service representative	Confirm the master.
Related part	Main board
Remarks	<ul style="list-style-type: none"> ▪ Free 1 is displayed. ▪ In the case of no free 1 No. automatic update, product master is not changed. ▪ Error screen can be changed in link master error settings. ▪ Master name can be checked in "Free master name settings".

■ Free 2 master is not registered (0213)

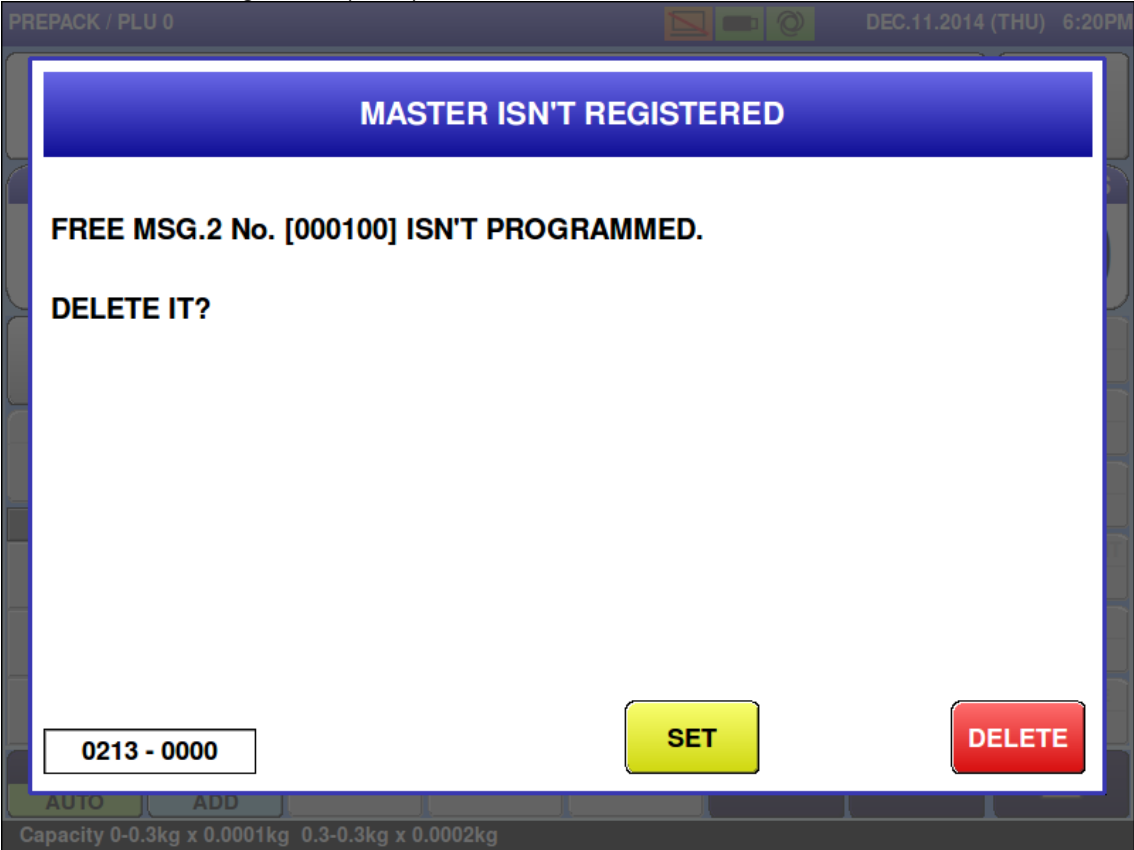

Error content	Free 2 master is not registered.
Detail	Does not exist in internal master.
Solution	[DELETE] button => Delete free No. 2 of product master. [SET] button => Cancel error.
Action by user	Reconfirm the free 2 master number. Add free 2 master.
Action by service representative	Confirm the master.
Related part	Main board
Remarks	<ul style="list-style-type: none"> ▪ Free 2 is displayed. ▪ In the case of no free 2 No. automatic update, product master is not changed. ▪ Error screen can be changed in link master error settings. ▪ Master name can be checked in "Free master name settings".

■ Free 3 master is not registered (0214)

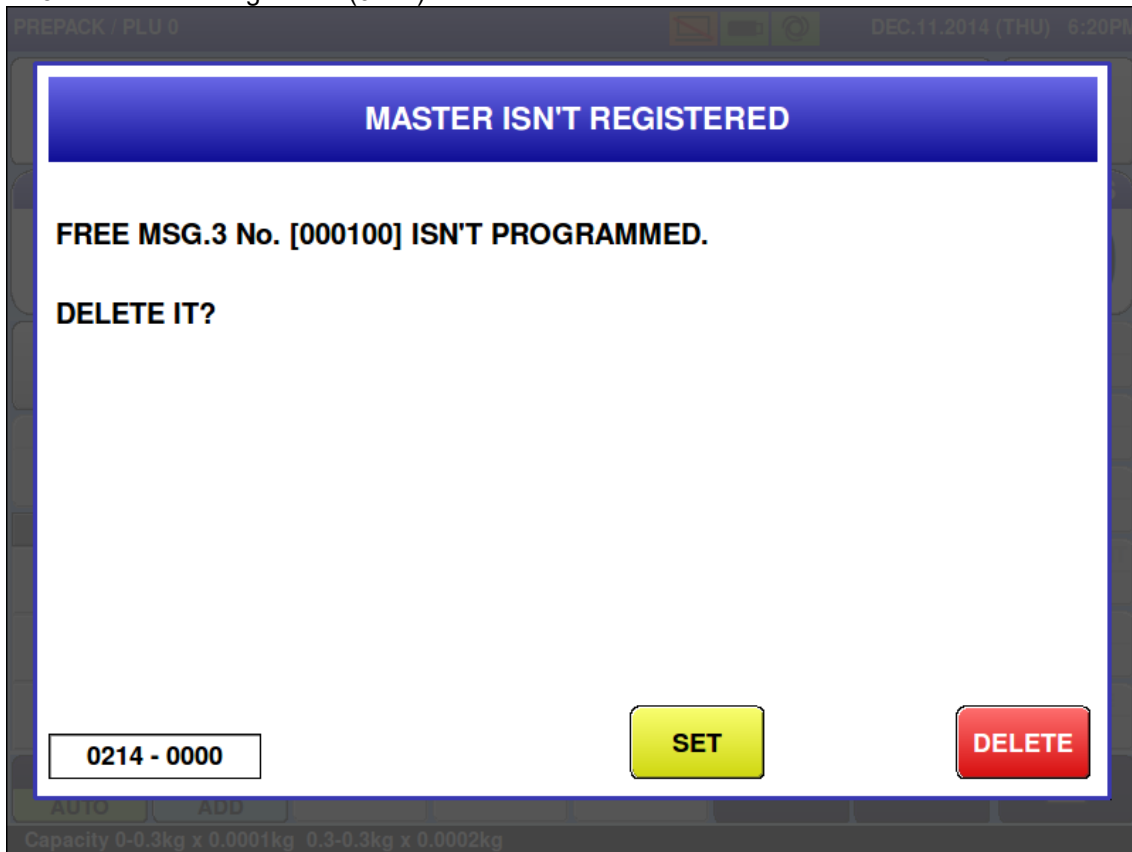

Error content	Free 3 master is not registered.
Detail	Does not exist in internal master.
Solution	[DELETE] button => Delete free No. 3 of product master. [SET] button => Cancel error.
Action by user	Reconfirm the free 3 master number. Add free 3 master.
Action by service representative	Confirm the master.
Related part	Main board
Remarks	<ul style="list-style-type: none"> ▪ Free 3 is displayed. ▪ In the case of no free 3 No. automatic update, product master is not changed. ▪ Error screen can be changed in link master error settings. ▪ Master name can be checked in "Free master name settings".

■ Free 4 master is not registered (0215)

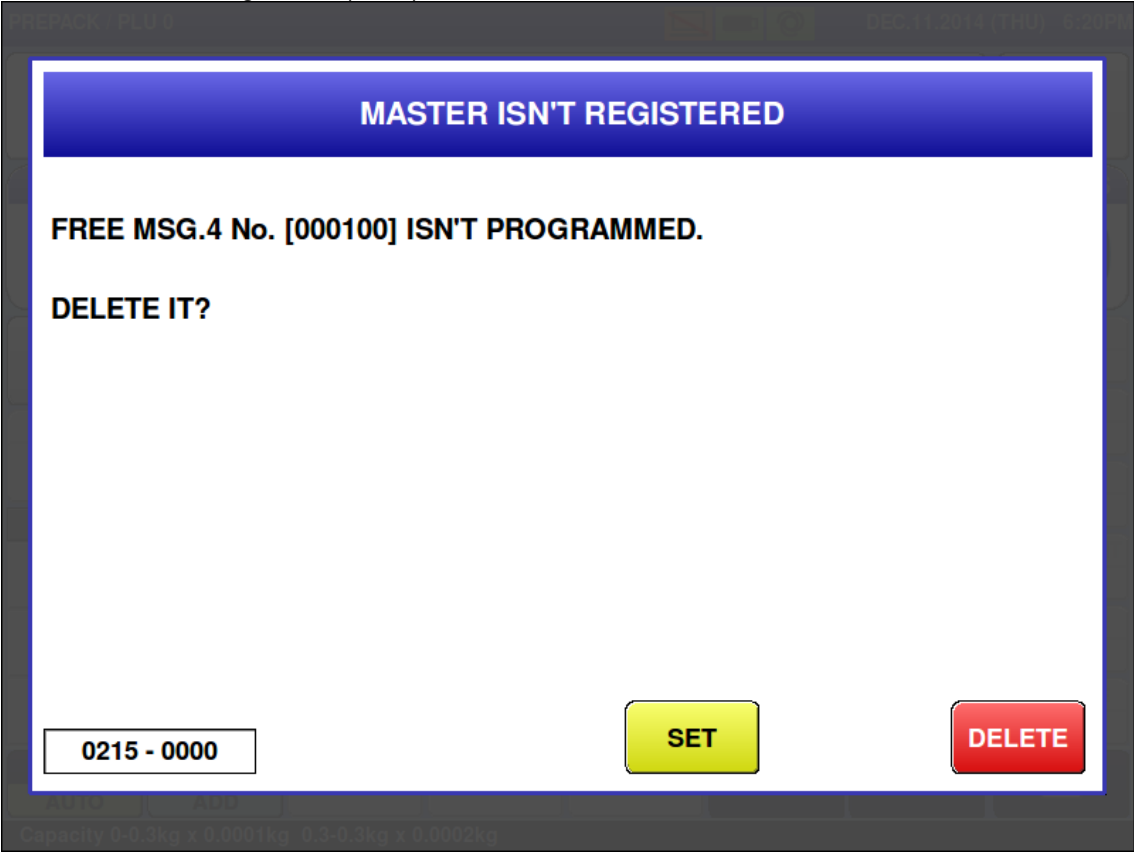

Error content	Free 4 master is not registered.
Detail	Does not exist in internal master.
Solution	[DELETE] button => Delete free No. 4 of product master. [SET] button => Cancel error.
Action by user	Reconfirm the free 4 master number. Add free 4 master.
Action by service representative	Confirm the master.
Related part	Main board
Remarks	<ul style="list-style-type: none"> ▪ Free 4 is displayed. ▪ In the case of no free 4 No. automatic update, product master is not changed. ▪ Error screen can be changed in link master error settings. ▪ Master name can be checked in "Free master name settings".

■ Free 5 master is not registered (0216)

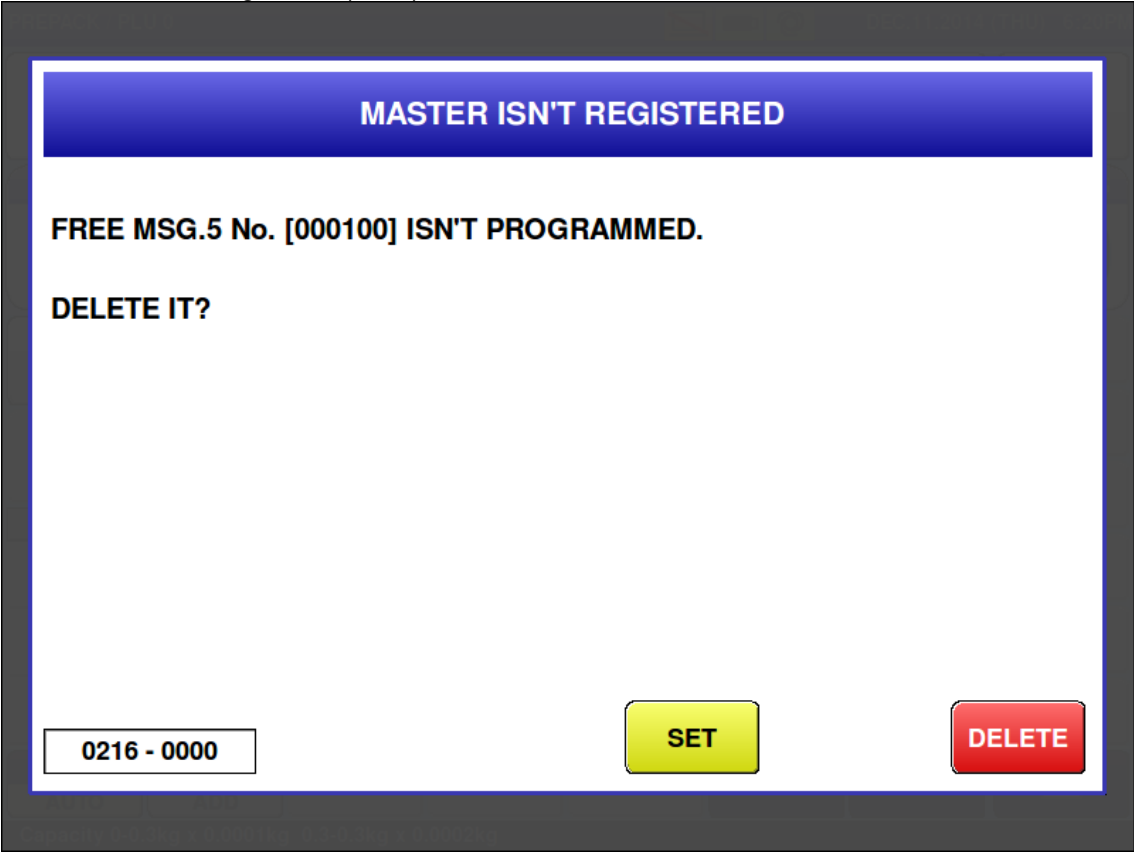

Error content	Free 5 master is not registered.
Detail	Does not exist in internal master.
Solution	[DELETE] button => Delete free No. 5 of product master. [SET] button => Cancel error.
Action by user	Reconfirm the free 5 master number. Add free 5 master.
Action by service representative	Confirm the master.
Related part	Main board
Remarks	<ul style="list-style-type: none"> ▪ Free 5 is displayed. ▪ In the case of no free 5 No. automatic update, product master is not changed. ▪ Error screen can be changed in link master error settings. ▪ Master name can be checked in "Free master name settings".

■ Amount of internal memory is short (0226)

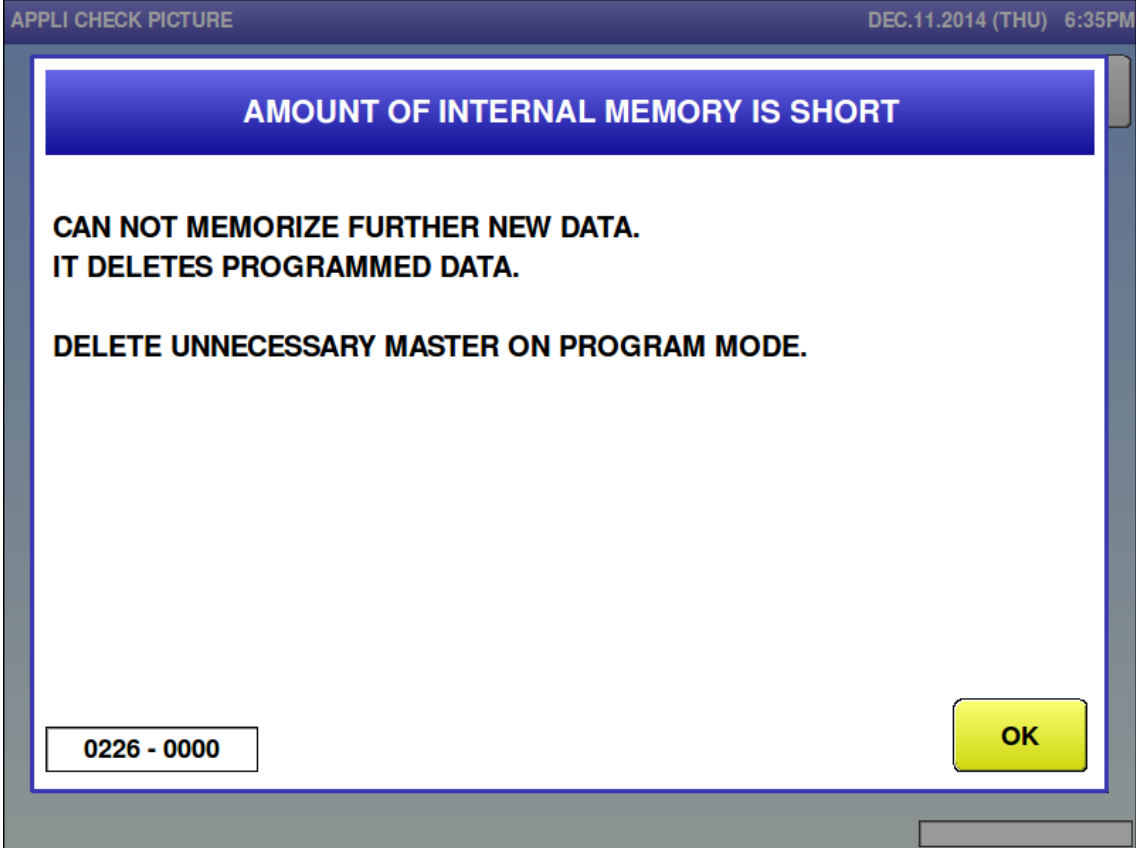

Error content	Amount of internal memory is short
Detail	Error indicates that memory space is insufficient when saving master to DB.
Solution	[OK] button, organize memory. Delete unnecessary data for each master using the [Organize Memory] function key.
Action by user	Perform Organize Memory using the [Organize Memory] function key. Delete unnecessary masters.
Action by service representative	Perform Organize Memory. Delete unnecessary masters.
Related part	Main board
Remarks	Sub error indicates each master No.

■ Amount of internal memory for total is full (0227)

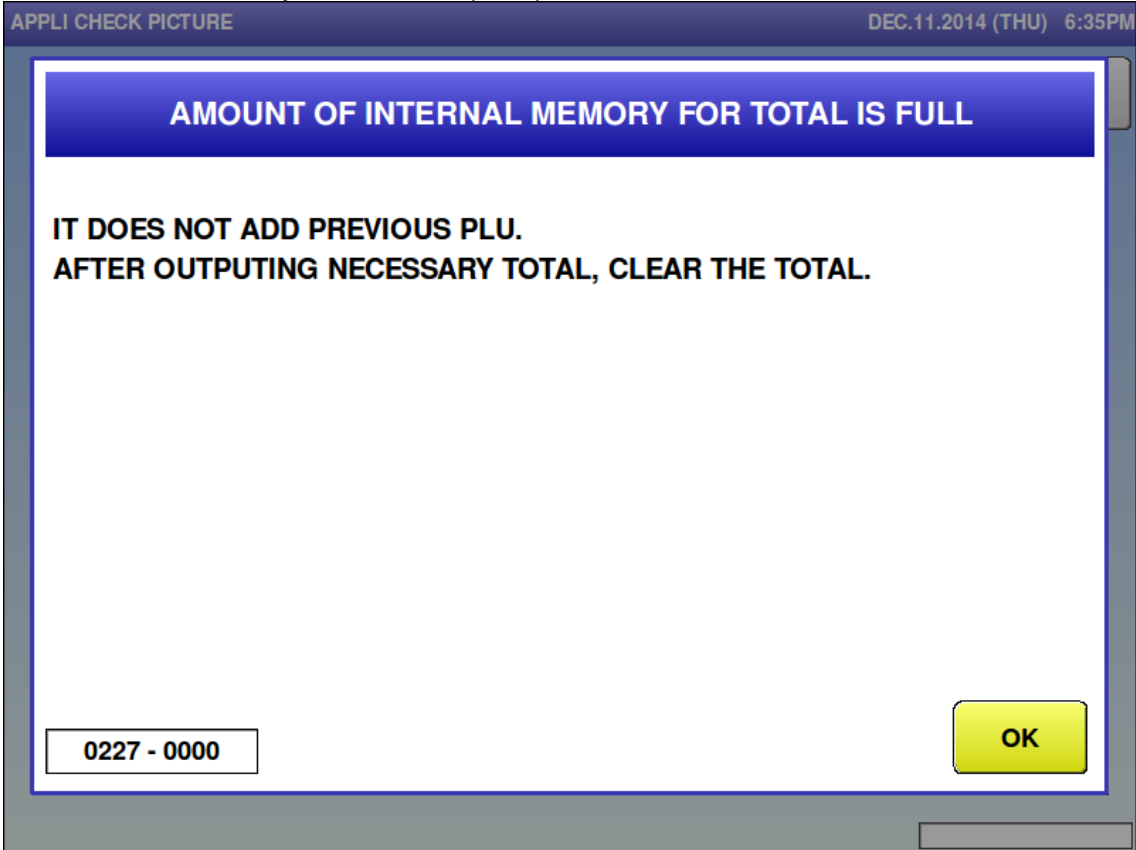

Error content	Amount of internal memory for total is full.
Detail	Error indicates that internal memory is insufficient when saving production result.
Solution	[OK] button and clear the total. Organize memory using the [Organize Memory] function key.
Action by user	Perform [Organize Memory] using the [Organize Memory] function key after deleting summary data. Delete unnecessary masters.
Action by service representative	Perform [Organize Memory]. Delete unnecessary masters.
Related part	Main board
Remarks	Make sure to organize memory after clearing the total.

■ File system is abnormal (0229)

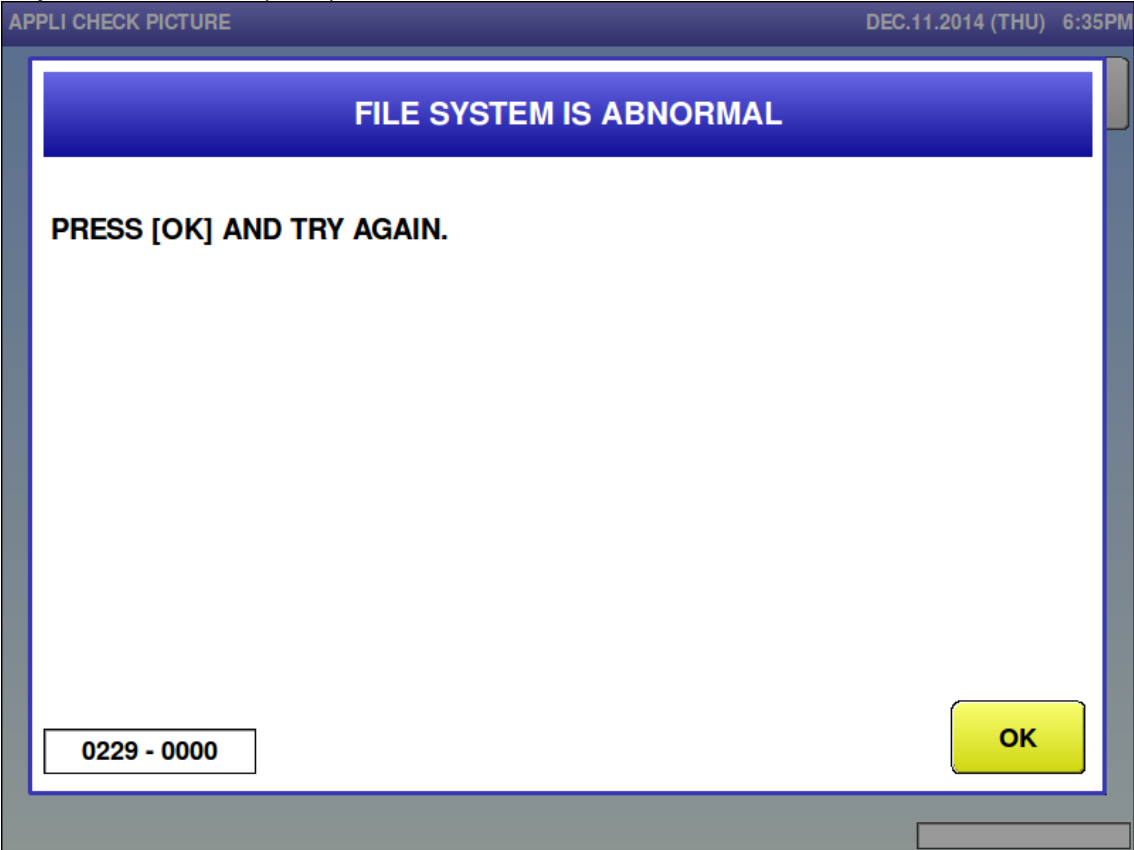

Error content	Occurs when there is an internal file is abnormal.
Detail	Failure of access to the program file of copy source, copy destination, and delete destination when downloading program.
Solution	[OK] button
Action by user	
Action by service representative	Confirm the internal master. Perform memory initialization. After that input the backup data.
Related part	Main board
Remarks	Check the program file of copy source, copy destination, and delete destination. 0229-0001 File System is Abnormal - Recovery from Backup indicates the memory has some corruption. When [OK] is pressed the wrapper should restore the files from its internal backup and return to normal operation. The internal backup was created the last time the wrapper powered down normally so the prices may be out of date. If the database is corrupted it will require a memory clear to resolve. Otherwise the message will continue to recur when the wrapper is powered off/on. After the memory clear, reload a good USB backup then download the current data from SLP-5. A potential cause of a corrupted database is disconnecting the power without turning off the power switch and waiting for the wrapper to completely shut down. Or, turning the power switch off and immediately back on. It can take up to a minute to fully shut down.

■ File input error (0266-0000)

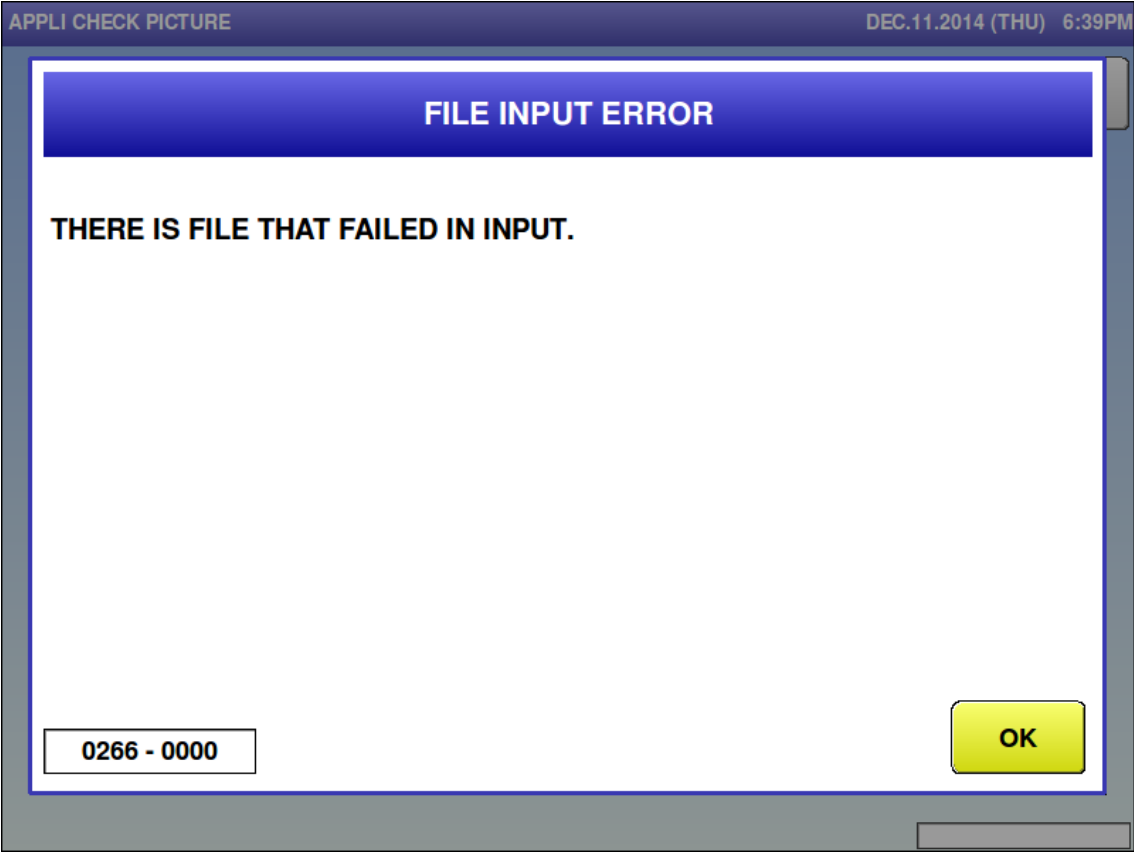

Error content	There is file that failed in input from external to internal device on the [SETUP: FILE SAVE/LOAD(INPUT) screen.
Detail	Input data is separated by sub-error No. 0000: Master data
Solution	[OK] button
Action by user	
Action by service representative	Confirm the internal master data.
Related part	Main board
Remarks	

■ File input error (0266-0001)

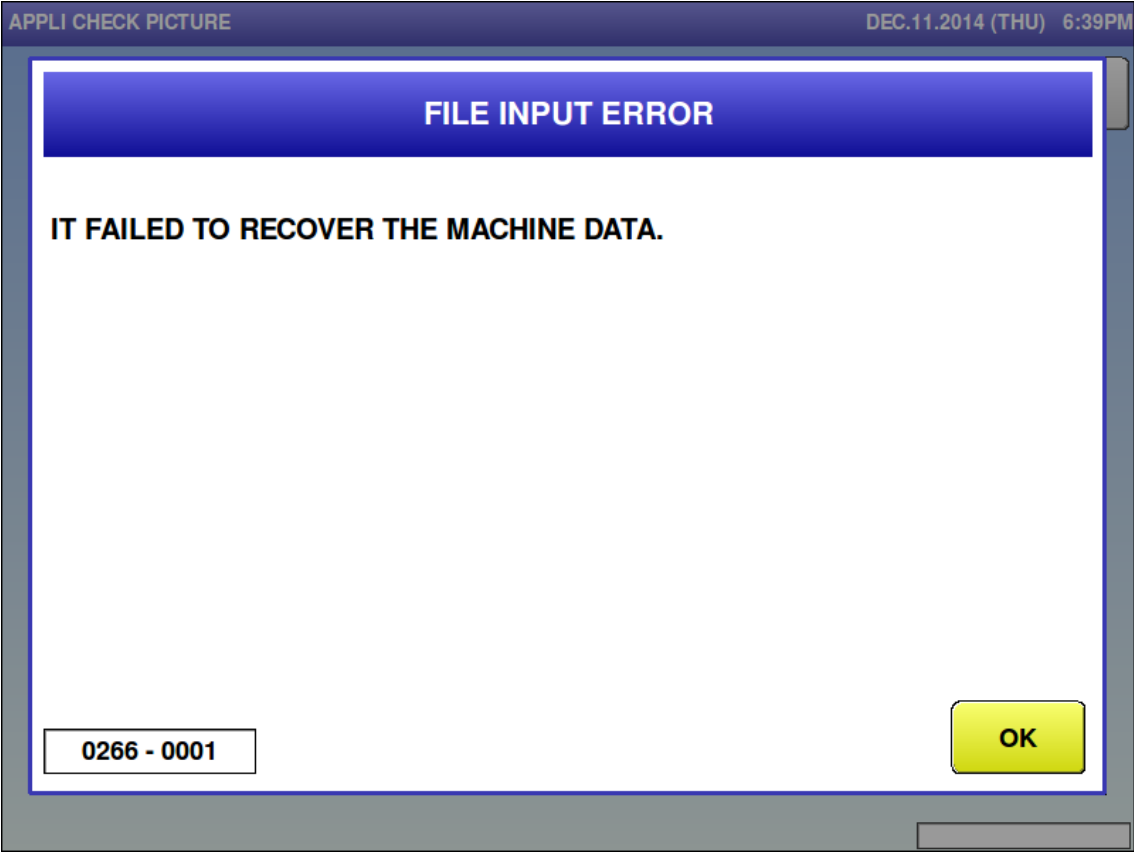

Error content	There is file that failed in input from external to internal device on the [SETUP: FILE SAVE/LOAD(INPUT) screen.
Detail	Input data is separated by sub-error No. 0001: SRAM data
Solution	[OK] button
Action by user	
Action by service representative	Confirm the internal master data.
Related part	Main board
Remarks	

■ File input error (0266-0002)

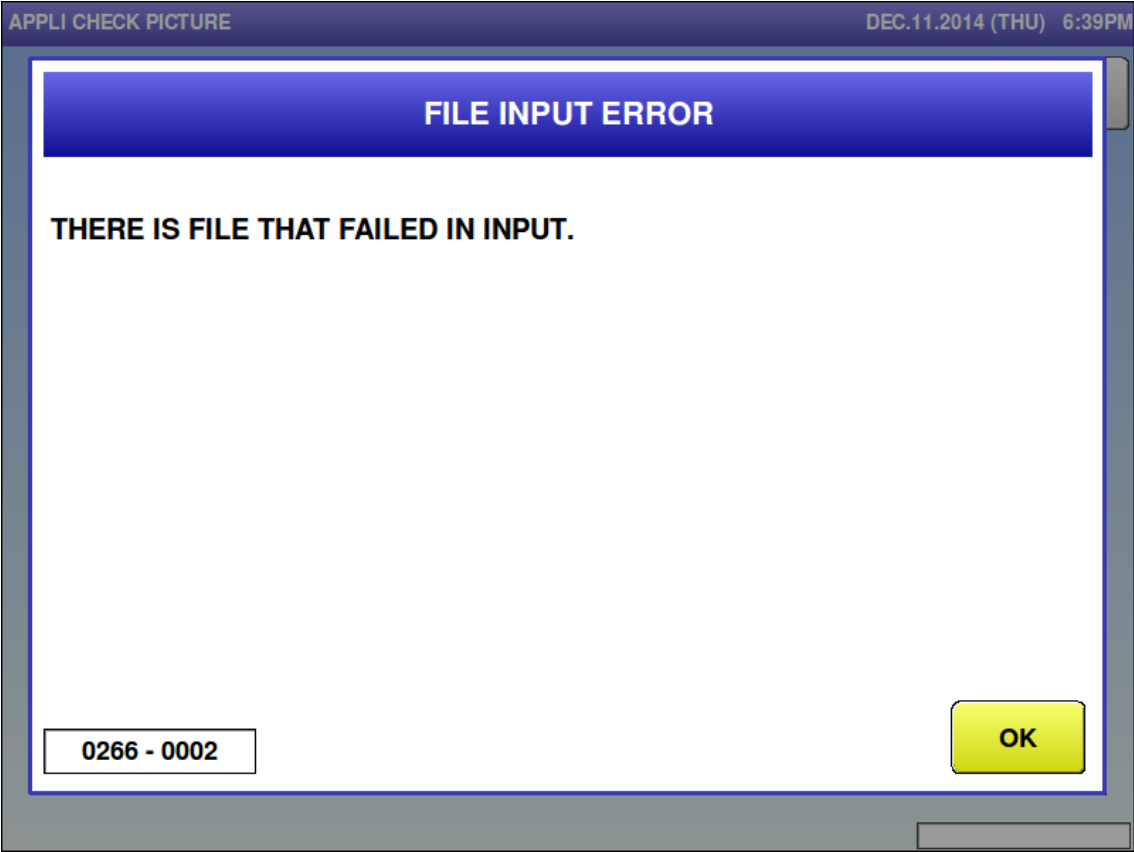

Error content	There is file that failed in input from external to internal device on the [SETUP: FILE SAVE/LOAD(INPUT) screen.
Detail	Input data is separated by sub-error No. 0002: Master data (all master)
Solution	[OK] button
Action by user	
Action by service representative	Confirm the internal master data.
Related part	Main board
Remarks	

- File output error (0267–0000)
File output error of master data

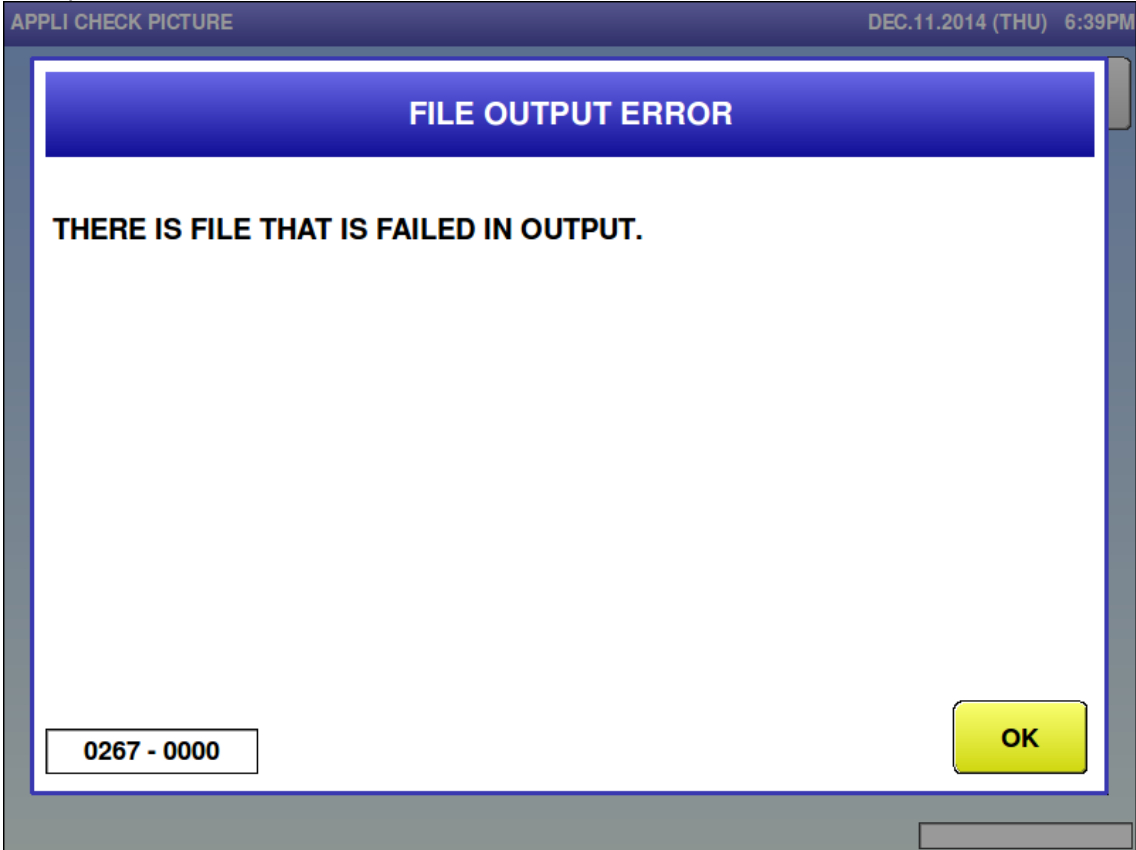

Error content	There is file that failed in output from internal to internal device on the [SETUP: FILE SAVE/LOAD(OUTPUT)] screen.
Detail	Output source data is separated by sub-error No. 0000: Master data
Solution	[OK] button
Action by user	
Action by service representative	Confirm the internal master data.
Related part	Main board
Remarks	

■ File output error (0267–0001)

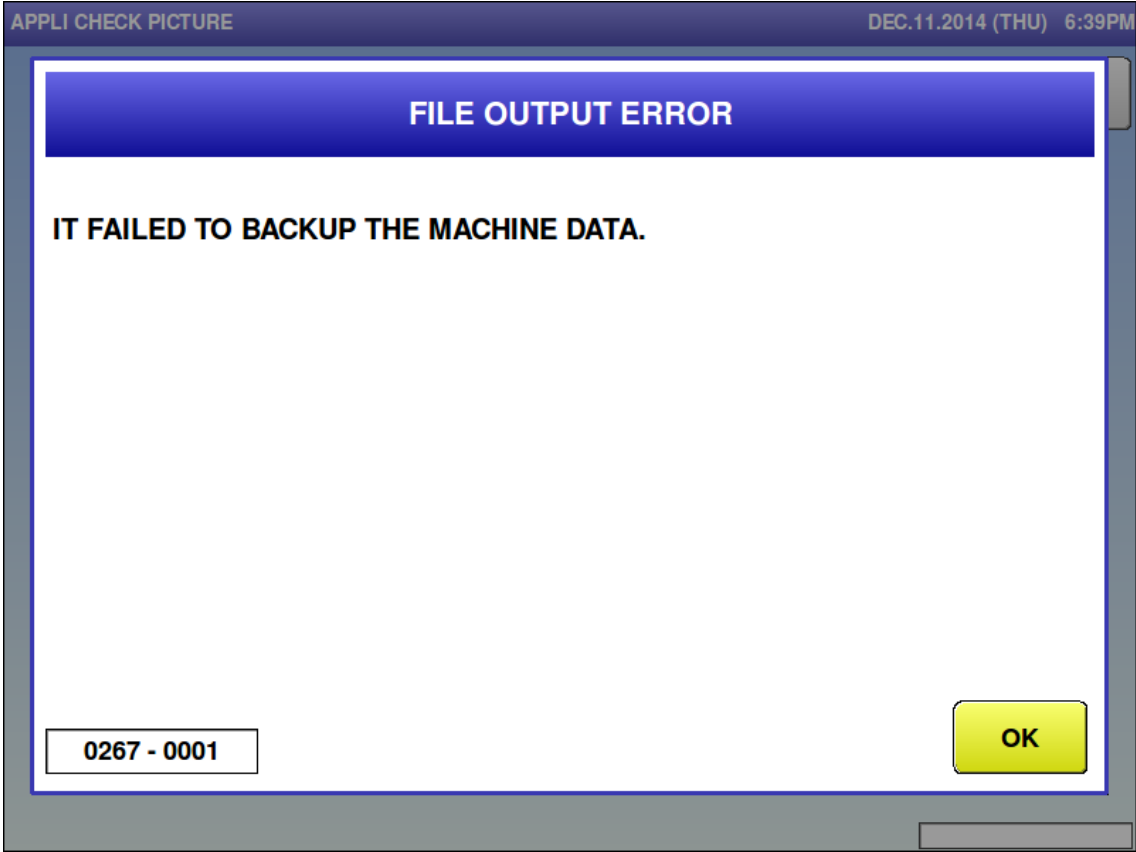

Error content	There is file that failed in output from internal to internal device on the [SETUP: FILE SAVE/LOAD(OUTPUT)] screen.
Detail	Output source data is separated by sub-error No. 0001: SRAM data
Solution	[OK] button
Action by user	
Action by service representative	Confirm the internal master data.
Related part	Main board
Remarks	

■ File output error (0267–0002)

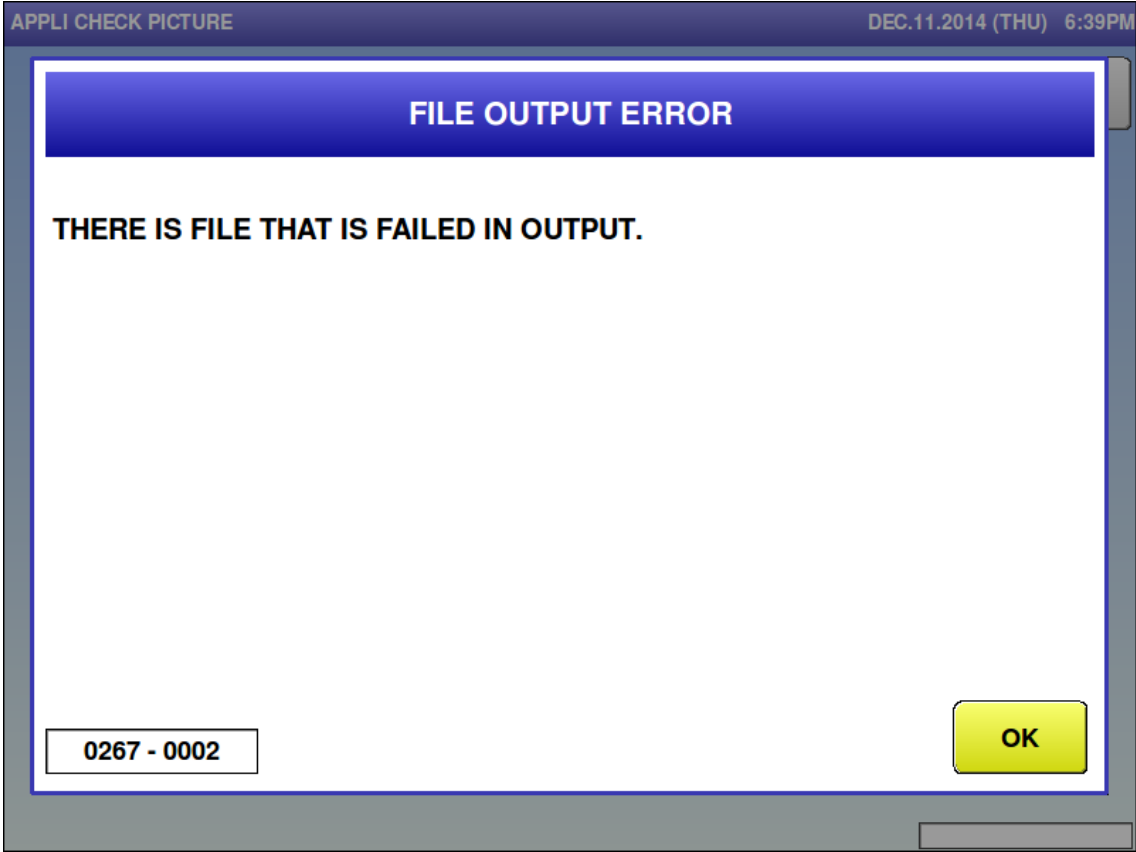

Error content	There is file that failed in output from internal to internal device on the [SETUP: FILE SAVE/LOAD(OUTPUT)] screen.
Detail	Output source data is separated by sub-error No. 0002: Master data (all master)
Solution	[OK] button
Action by user	
Action by service representative	Confirm the internal master data.
Related part	Main board
Remarks	

■ File delete error (0268-0000)

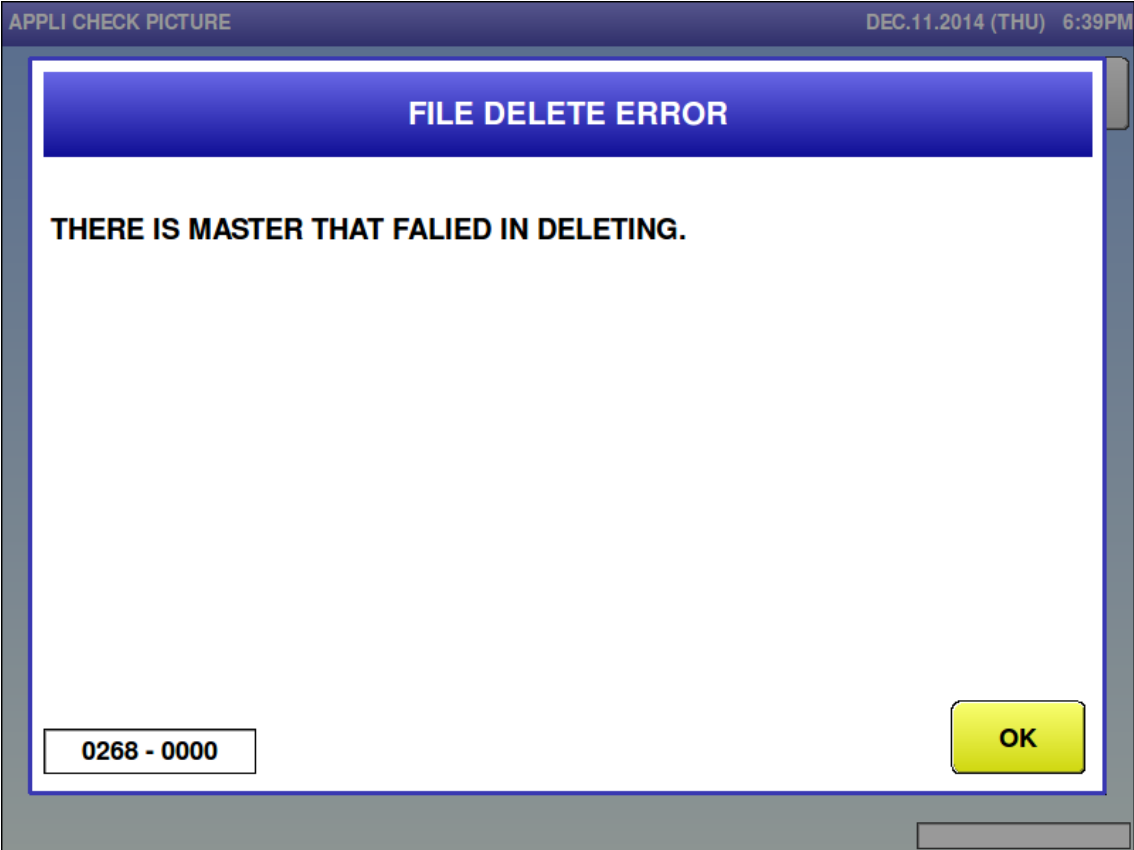

Error content	There is external device data or SRAM data that failed in deleting on the [SETUP: FILE SAVE/LOAD(DELETE)] screen.
Detail	Data to delete is separated by sub-error No. 0000: External device data (master specified)
Solution	[OK] button
Action by user	
Action by service representative	Confirm the internal master data.
Related part	Main board
Remarks	

■ File delete error (0268-0001)

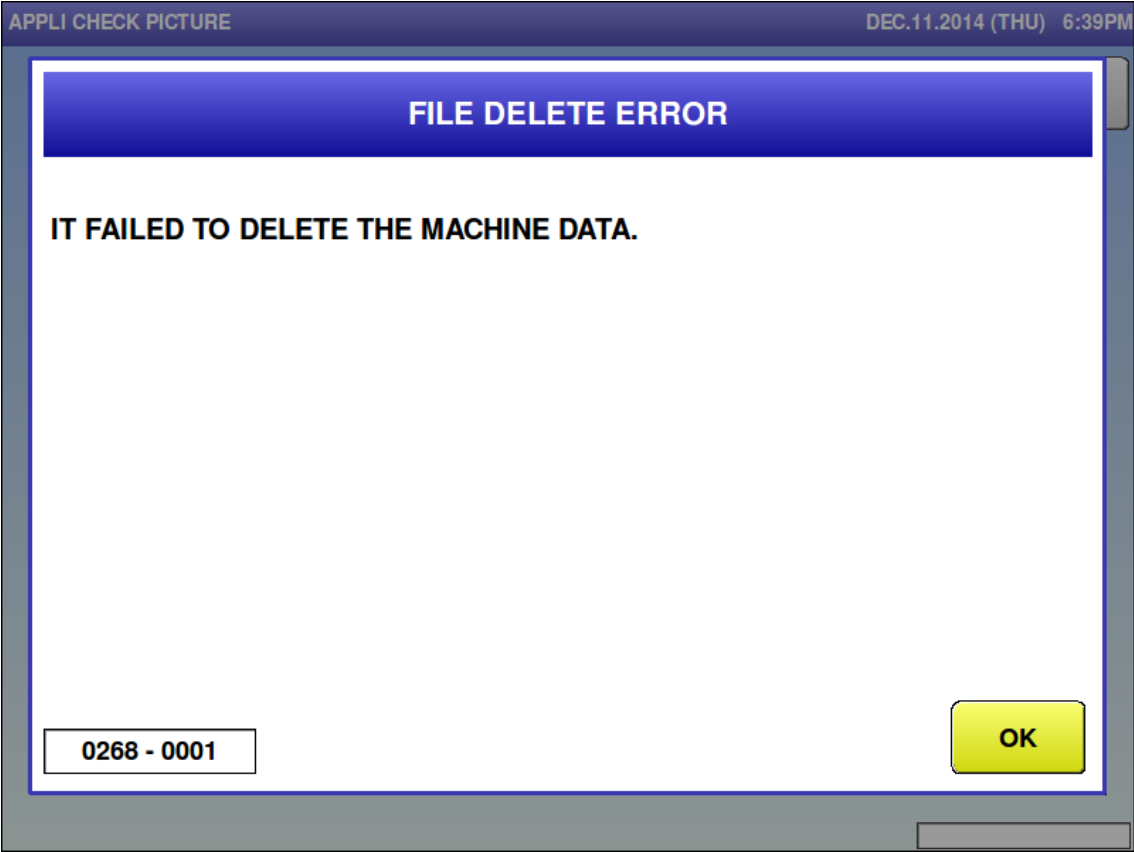

Error content	There is external device data or SRAM data that failed in deleting on the [SETUP: FILE SAVE/LOAD(DELETE)] screen.
Detail	Data to delete is separated by sub-error No. 0001: SRAM data
Solution	[OK] button
Action by user	
Action by service representative	Confirm the internal master data.
Related part	Main board
Remarks	

■ File delete error (0268-0002)

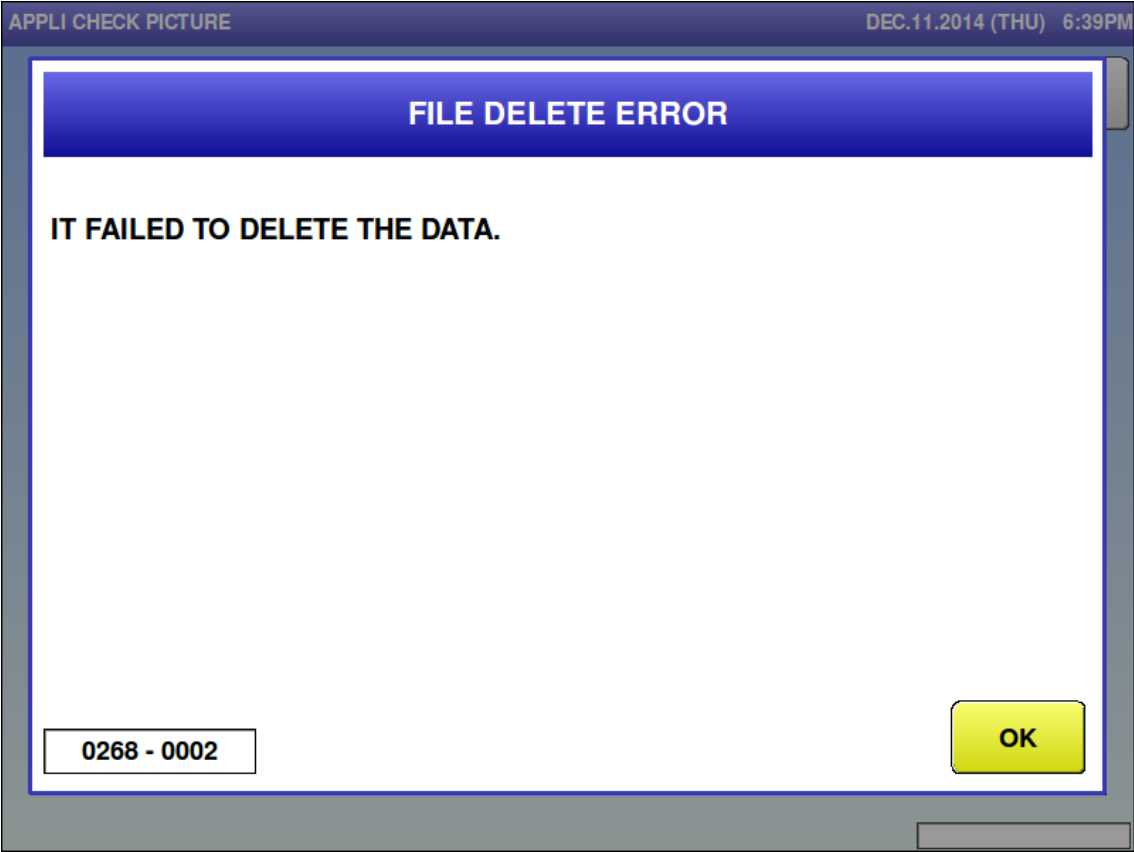

Error content	There is external device data or SRAM data that failed in deleting on the [SETUP: FILE SAVE/LOAD(DELETE)] screen.
Detail	Data to delete is separated by sub-error No. 0002: External device data (data specified)
Solution	[OK] button
Action by user	
Action by service representative	Confirm the internal master data.
Related part	Main board
Remarks	

■ File delete error (0268-0003)

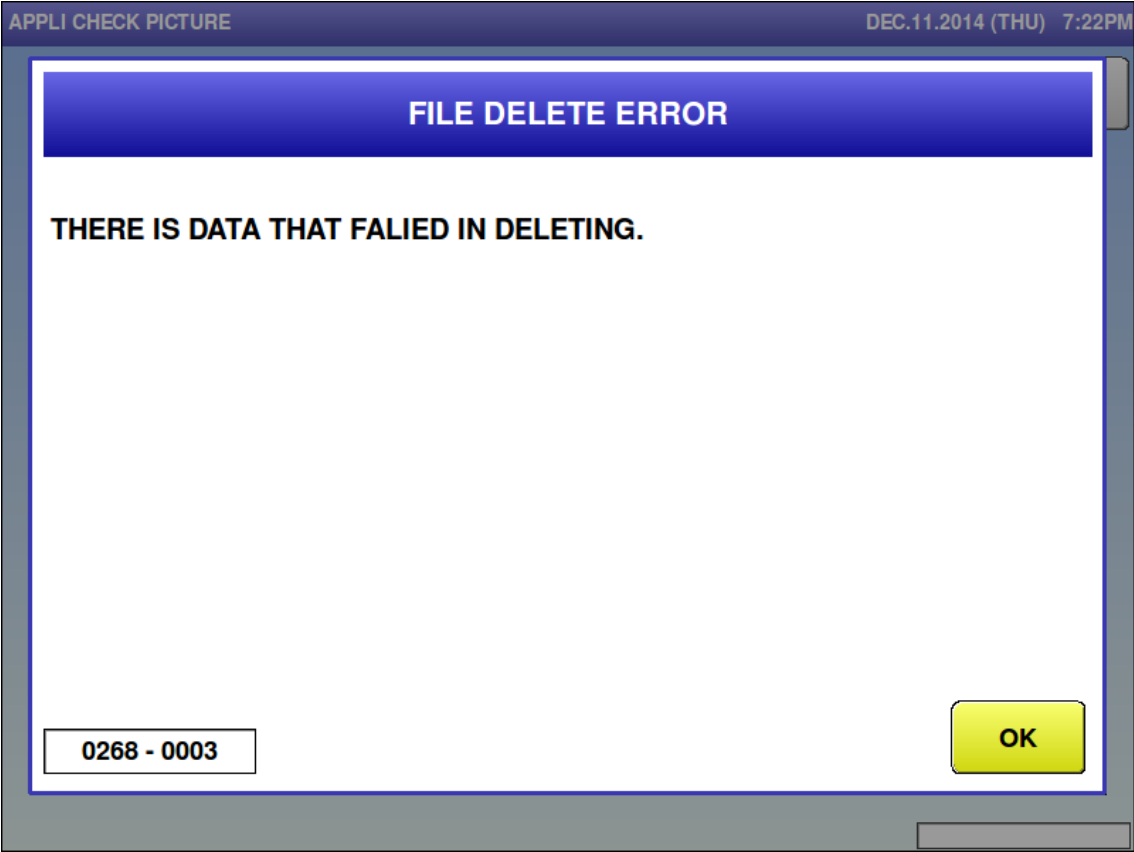

Error content	There is external device data or SRAM data that failed in deleting on the [SETUP: FILE SAVE/LOAD(DELETE)] screen.
Detail	Data to delete is separated by sub-error No. 0003: External device data (all data)
Solution	[OK] button
Action by user	
Action by service representative	Confirm the internal master data.
Related part	Main board
Remarks	

■ Initialize error (0271)

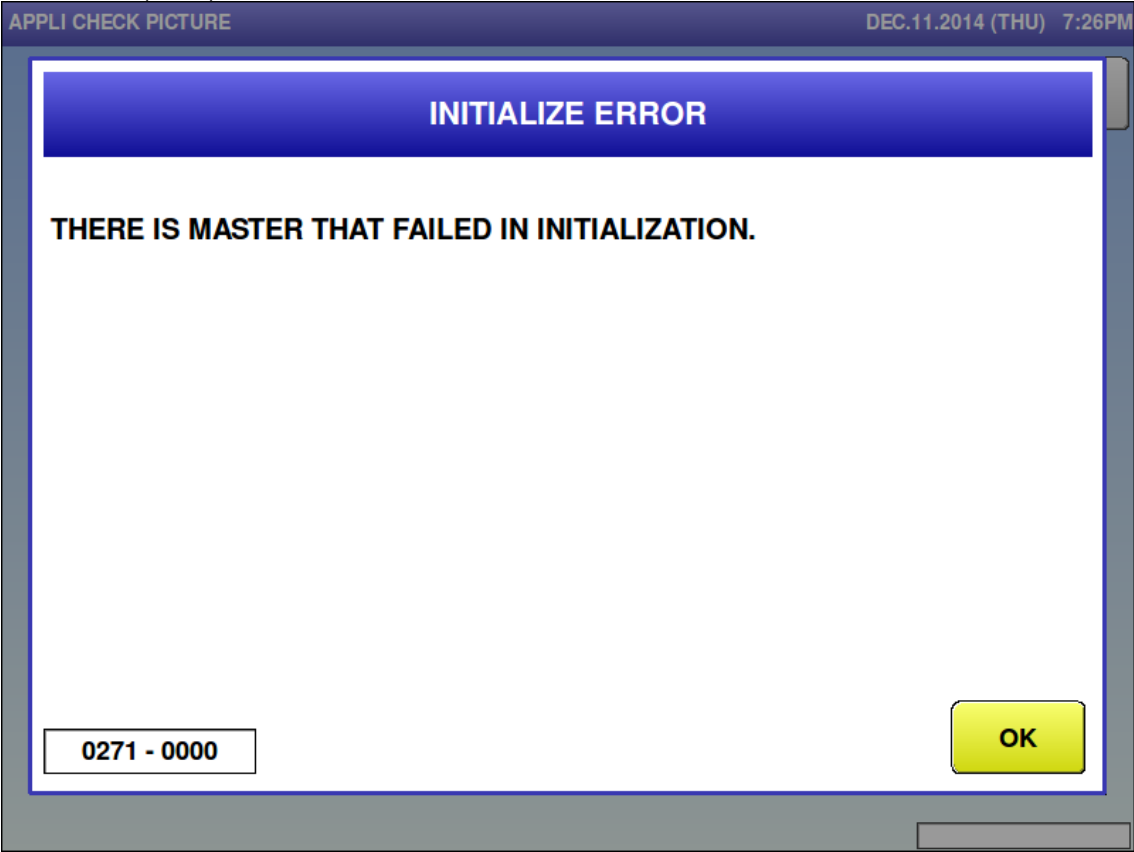

Error content	There is internal master that failed in initialization on the [SETUP: FILE SAVE/LOAD(INIT.)] screen.
Detail	
Solution	[OK] button
Action by user	
Action by service representative	Confirm the internal master data.
Related part	Main board
Remarks	

- Extra message 1 master is not programmed (0286)

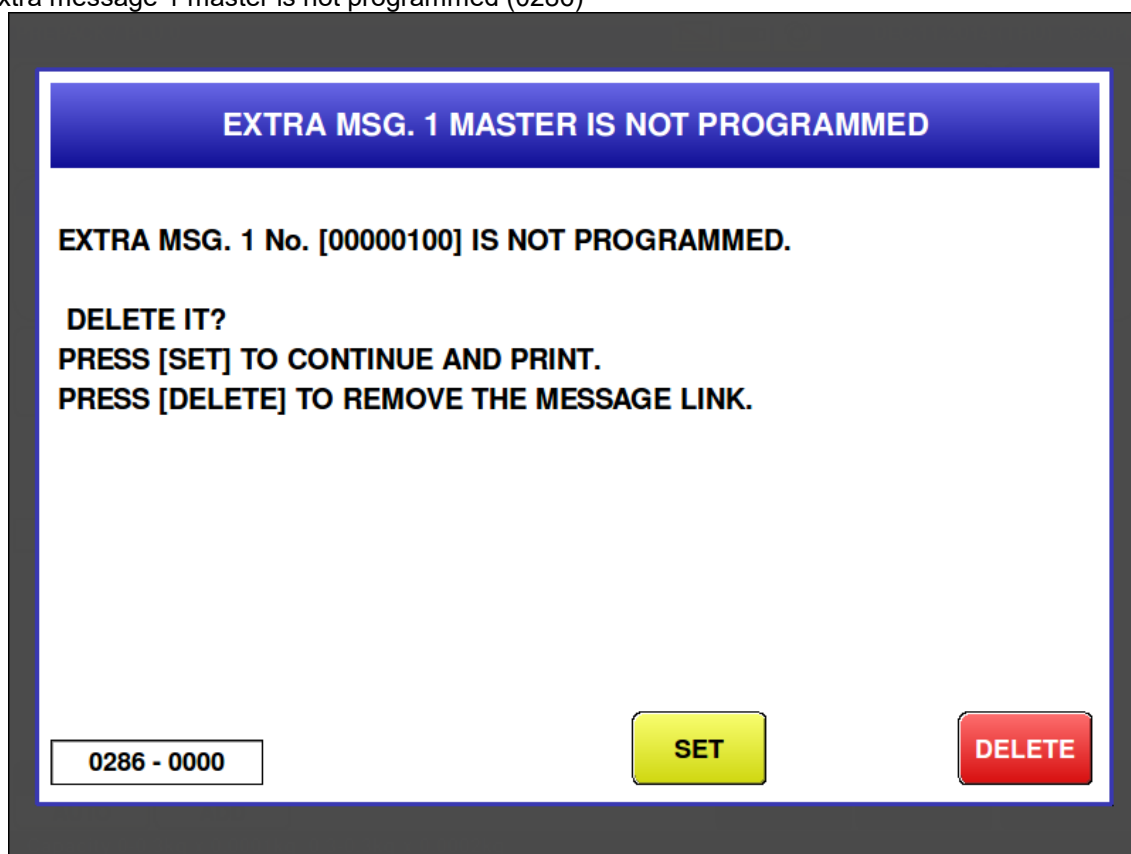

Error content	The called extra message 1 master has not been registered.
Detail	Does not exist in the internal master.
Solution	[DELETE] button => Delete extra message 1 No. of product master. [SET] button => Cancel error.
Action by user	Reconfirm the extra message 1 master number. Add the extra message 1 master.
Action by service representative	Confirm the master.
Related part	Main board
Remarks	<ul style="list-style-type: none"> • The called extra message 1 No. is displayed. • In the case of no extra message 1 No. update, product master is not changed. • Error screen can be changed in link master error settings. • Master name can be checked in "MENU TITLE (OPERATE) settings".

■ Ingredient master is not programmed (0287)

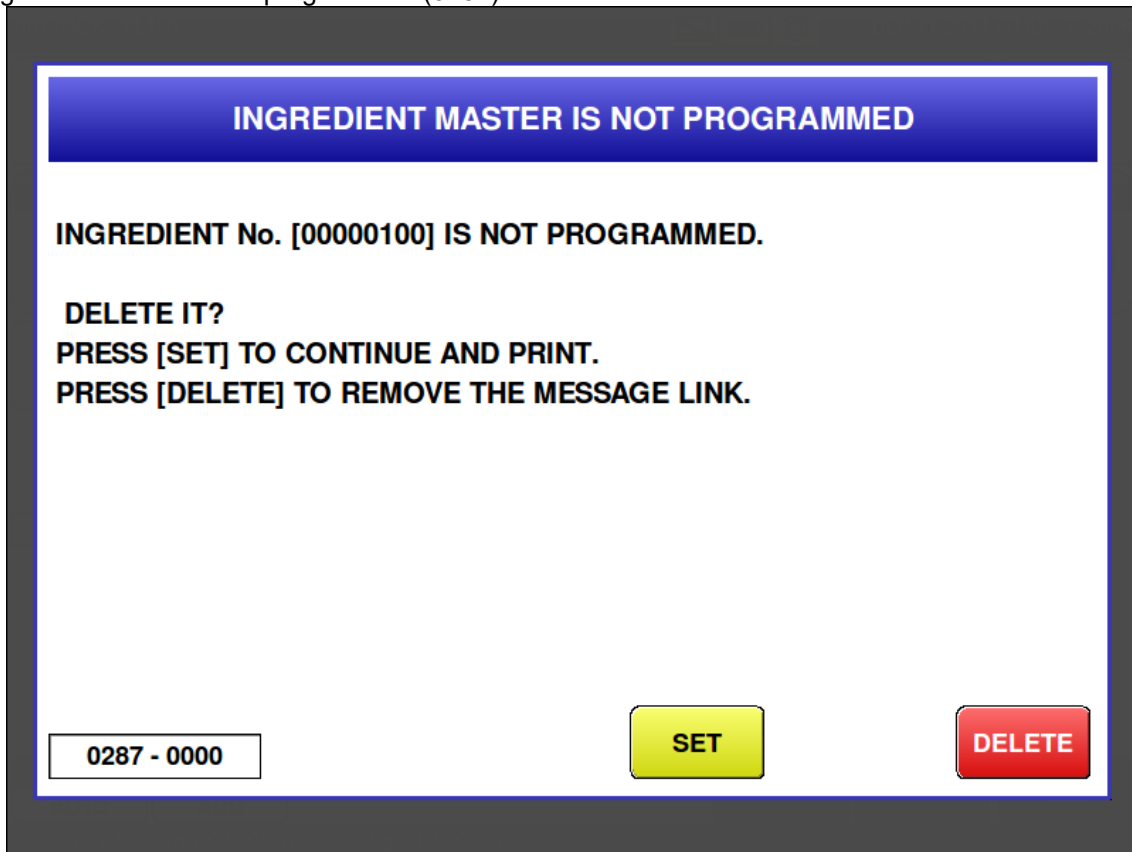

Error content	The called ingredient master has not been registered.
Detail	Does not exist in the internal master.
Solution	[DELETE] button => Delete ingredient No. of product master. [SET] button => Cancel error.
Action by user	Reconfirm the ingredient master number. Add the ingredient master.
Action by service representative	Confirm the master.
Related part	Main board
Remarks	<ul style="list-style-type: none"> ▪ The called ingredient No. is displayed. ▪ In the case of no ingredient No. update, product master is not changed. ▪ Error screen can be changed in link master error settings. ▪ Master name can be checked in "MENU TITLE (OPERATE) settings".

- Extra message 3 master is not programmed (0289)

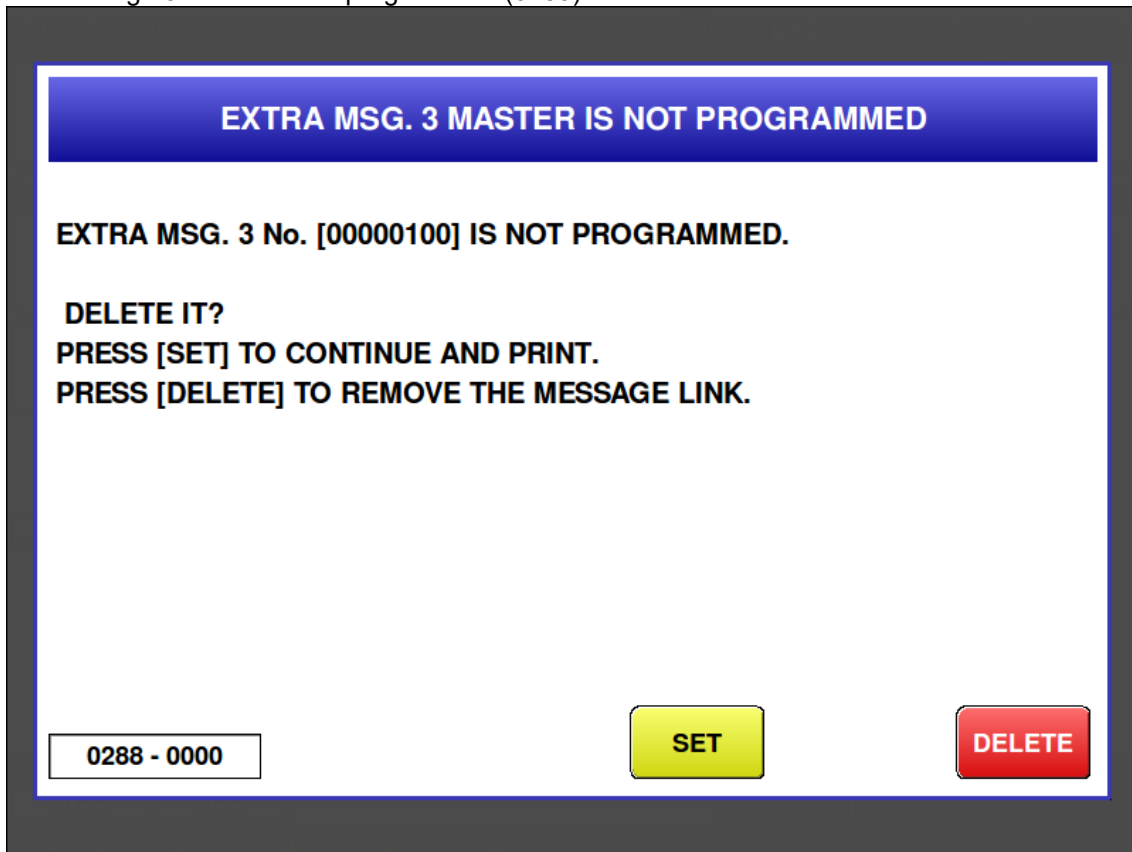

Error content	The called extra message 3 master has not been registered.
Detail	Does not exist in the internal master.
Solution	[DELETE] button => Delete extra message 3 No. of product master. [SET] button => Cancel error.
Action by user	Reconfirm the extra message 3 master number. Add the extra message 3 master.
Action by service representative	Confirm the master.
Related part	Main board
Remarks	<ul style="list-style-type: none"> • The called extra message 3 No. is displayed. • In the case of no extra message 3 No. update, product master is not changed. • Error screen can be changed in link master error settings. • Master name can be checked in "MENU TITLE (OPERATE) settings".

■ Free 6 master is not registered (0294)

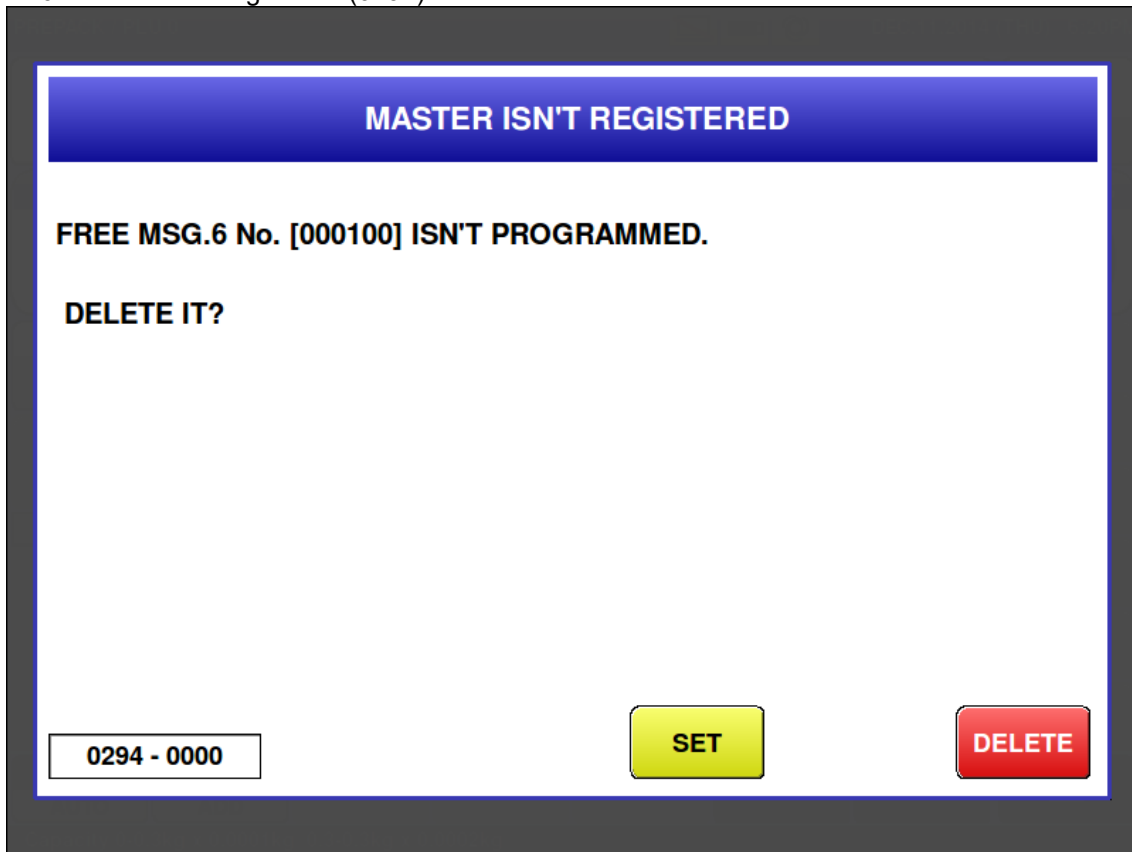

Error content	The called free 6 master has not been registered.
Detail	Does not exist in the internal master.
Solution	[DELETE] button => Delete free 6 No. of product master. [SET] button => Cancel error.
Action by user	Reconfirm the free 6 master number. Add the free 6 master.
Action by service representative	Confirm the master.
Related part	Main board
Remarks	<ul style="list-style-type: none"> ▪ The called free 6 No. is displayed. ▪ In the case of no free 6 No. update, product master is not changed. ▪ Error screen can be changed in link master error settings. ▪ Master name can be checked in "MENU TITLE (OPERATE) settings".

■ Free 7 master is not registered (0295)

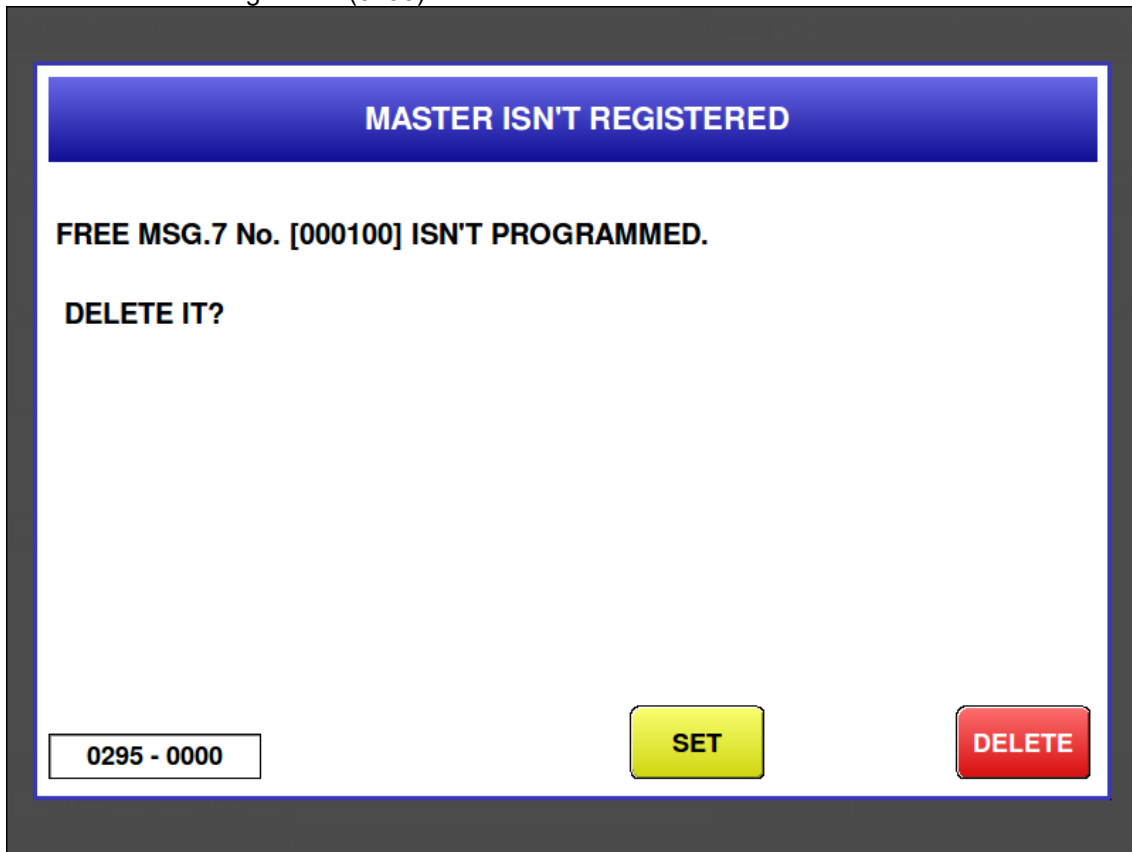

Error content	The called free 7 master has not been registered.
Detail	Does not exist in the internal master.
Solution	[DELETE] button => Delete free 7 No. of product master. [SET] button => Cancel error.
Action by user	Reconfirm the free 7 master number. Add the free 7 master.
Action by service representative	Confirm the master.
Related part	Main board
Remarks	<ul style="list-style-type: none"> ▪ The called free 7 No. is displayed. ▪ In the case of no free 7 No. update, product master is not changed. ▪ Error screen can be changed in link master error settings. ▪ Master name can be checked in "MENU TITLE (OPERATE) settings".

■ Free 8 master is not registered (0296)

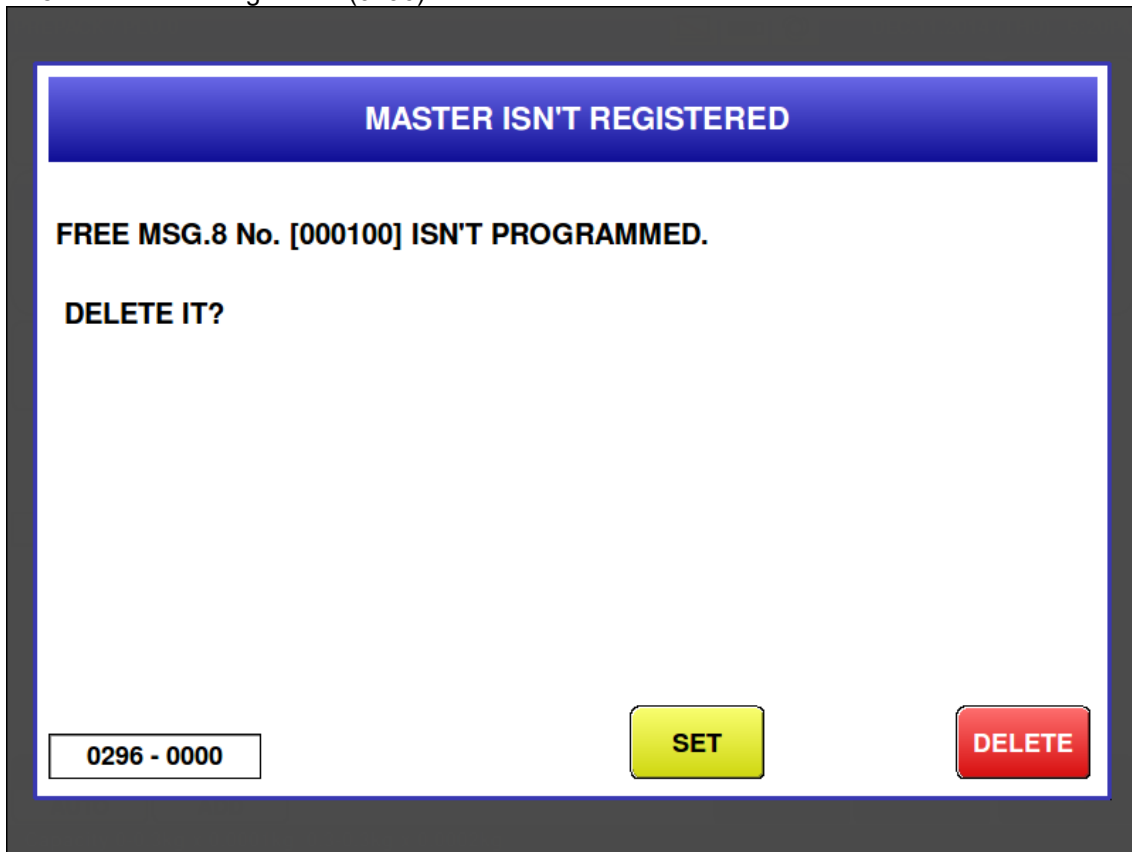

Error content	The called free 8 master has not been registered.
Detail	Does not exist in the internal master.
Solution	[DELETE] button => Delete free 8 No. of product master. [SET] button => Cancel error.
Action by user	Reconfirm the free 8 master number. Add the free 8 master.
Action by service representative	Confirm the master.
Related part	Main board
Remarks	<ul style="list-style-type: none"> ▪ The called free 8 No. is displayed. ▪ In the case of no free 8 No. update, product master is not changed. ▪ Error screen can be changed in link master error settings. ▪ Master name can be checked in "MENU TITLE (OPERATE) settings".

■ Free 9 master is not registered (0297)

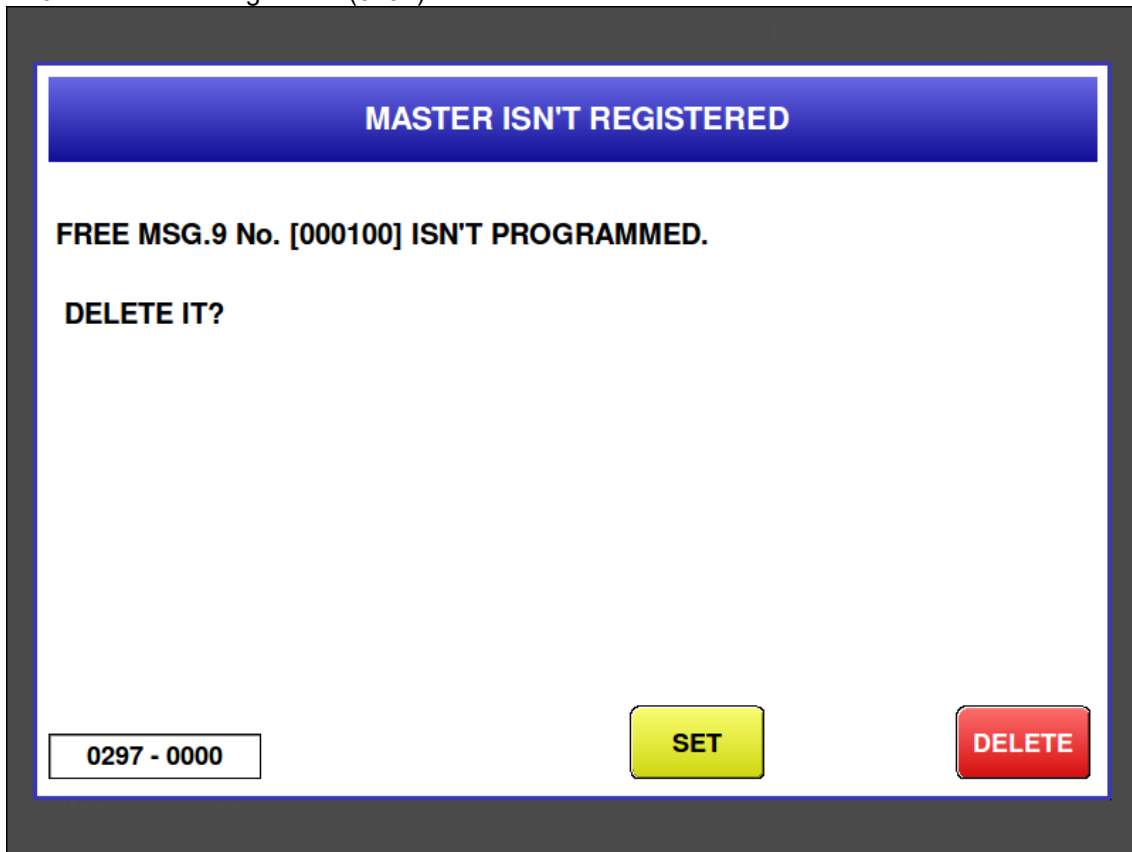

Error content	The called free 9 master has not been registered.
Detail	Does not exist in the internal master.
Solution	[DELETE] button => Delete free 9 No. of product master. [SET] button => Cancel error.
Action by user	Reconfirm the free 9 master number. Add the free 9 master.
Action by service representative	Confirm the master.
Related part	Main board
Remarks	<ul style="list-style-type: none"> ▪ The called free 9 No. is displayed. ▪ In the case of no free 9 No. update, product master is not changed. ▪ Error screen can be changed in link master error settings. ▪ Master name can be checked in "MENU TITLE (OPERATE) settings".

■ Free 10 master is not registered (0298)

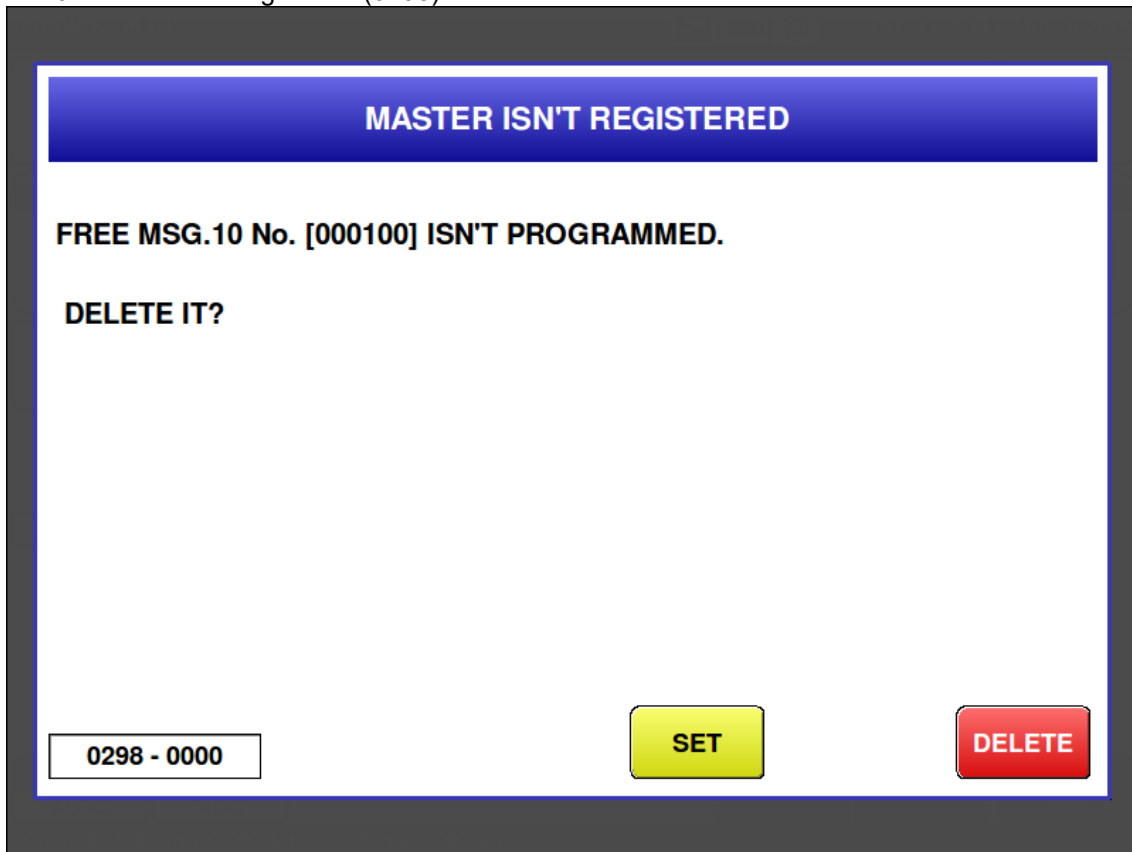

Error content	The called free 10 master has not been registered.
Detail	Does not exist in the internal master.
Solution	[DELETE] button => Delete free 10 No. of product master. [SET] button => Cancel error.
Action by user	Reconfirm the free 10 master number. Add the free 10 master.
Action by service representative	Confirm the master.
Related part	Main board
Remarks	<ul style="list-style-type: none"> ▪ The called free 10 No. is displayed. ▪ In the case of no free 10 No. update, product master is not changed. ▪ Error screen can be changed in link master error settings. ▪ Master name can be checked in "MENU TITLE (OPERATE) settings".

6.3.3 Precheck-related Error (No. 300s)

- Emergency switch has been pushed (0301)

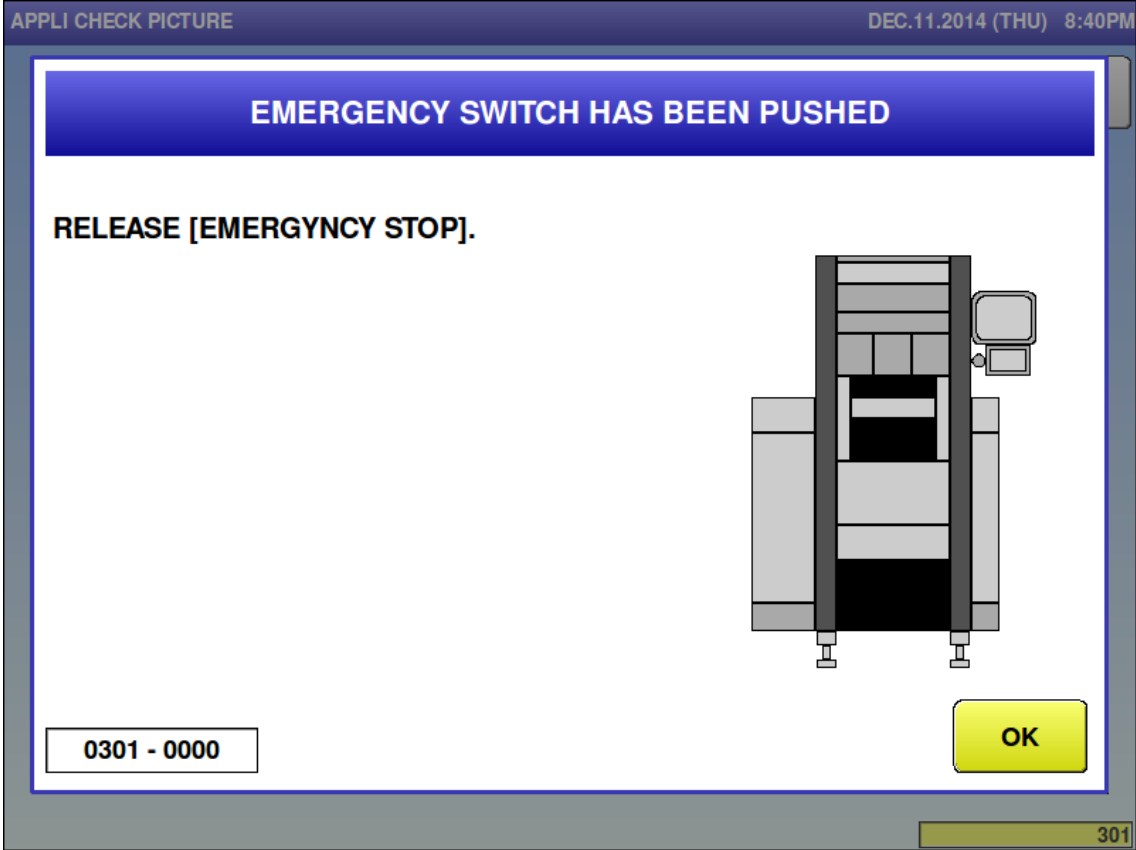

Error content	Emergency switch has been pushed.
Detail	The emergency stop switch is pushed before operation. The emergency stop switch is blinking red on the wrapping unit display.
Solution	Release emergency stop switch, [OK] button.
Action by user	Release the emergency stop button.
Action by service representative	Release the emergency stop button.
Related part	Main board, wrapping machine board
Remarks	

■ Front cover is open (0303)

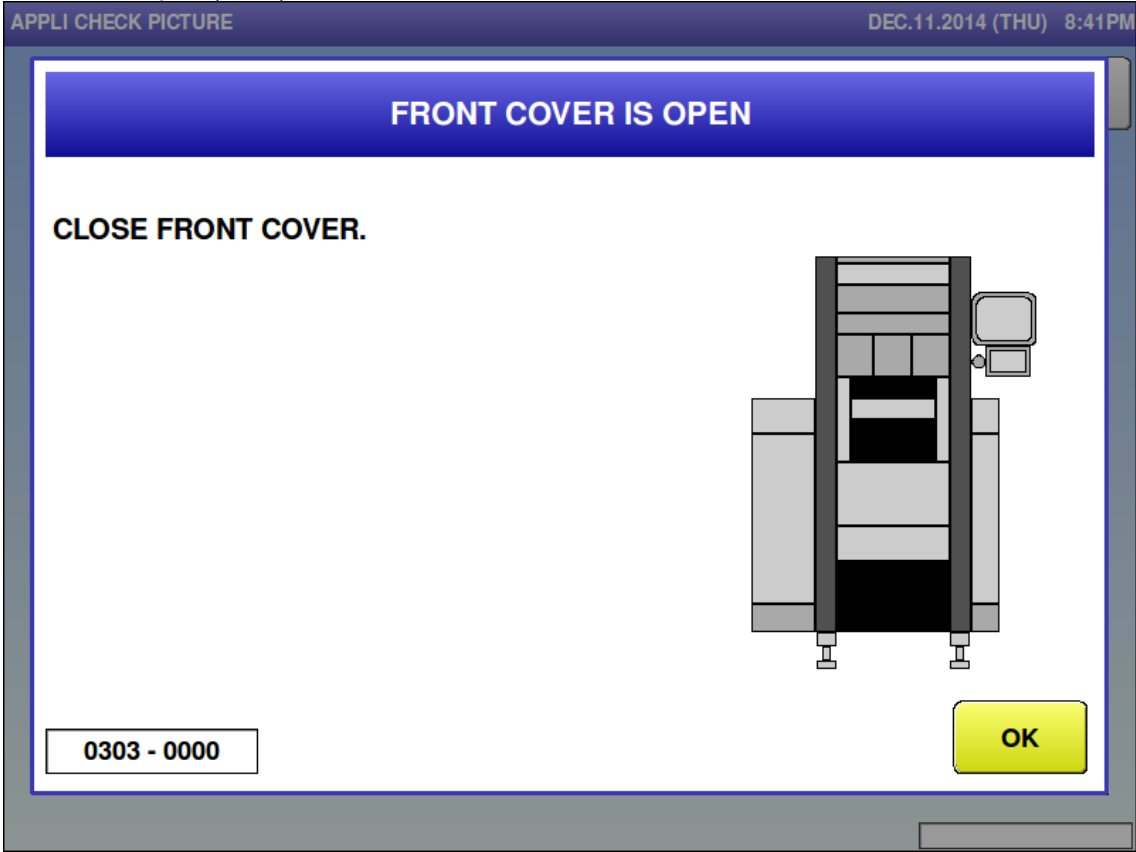

Error content	Front cover is open.
Detail	Occurs when the front cover is open. before operation.
Solution	Close the front cover, [OK] button.
Action by user	Close the front cover.
Action by service representative	Close the front cover.
Related part	Main board, wrapping machine board
Remarks	

■ Infeed is slided (0305)

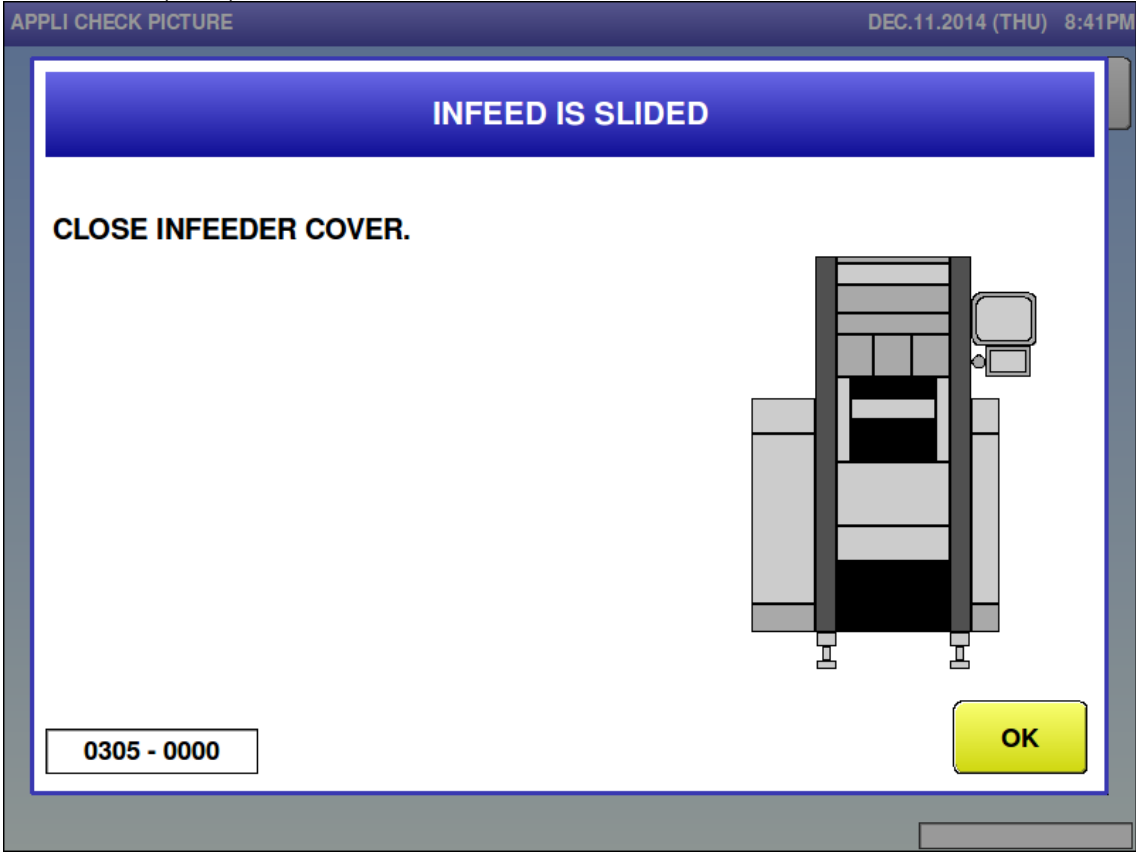

Error content	Infeed is slided
Detail	Occurs when the infeed conveyor or infeed cover is open before operation.
Solution	Set the infeed conveyor or close infeed cover, [OK] button.
Action by user	Close the infeed bottom cover. Set the infeed unit.
Action by service representative	Close the infeed bottom cover. Set the infeed unit.
Related part	Main board, wrapping machine board
Remarks	

■ Right film remove cover is open (0306)

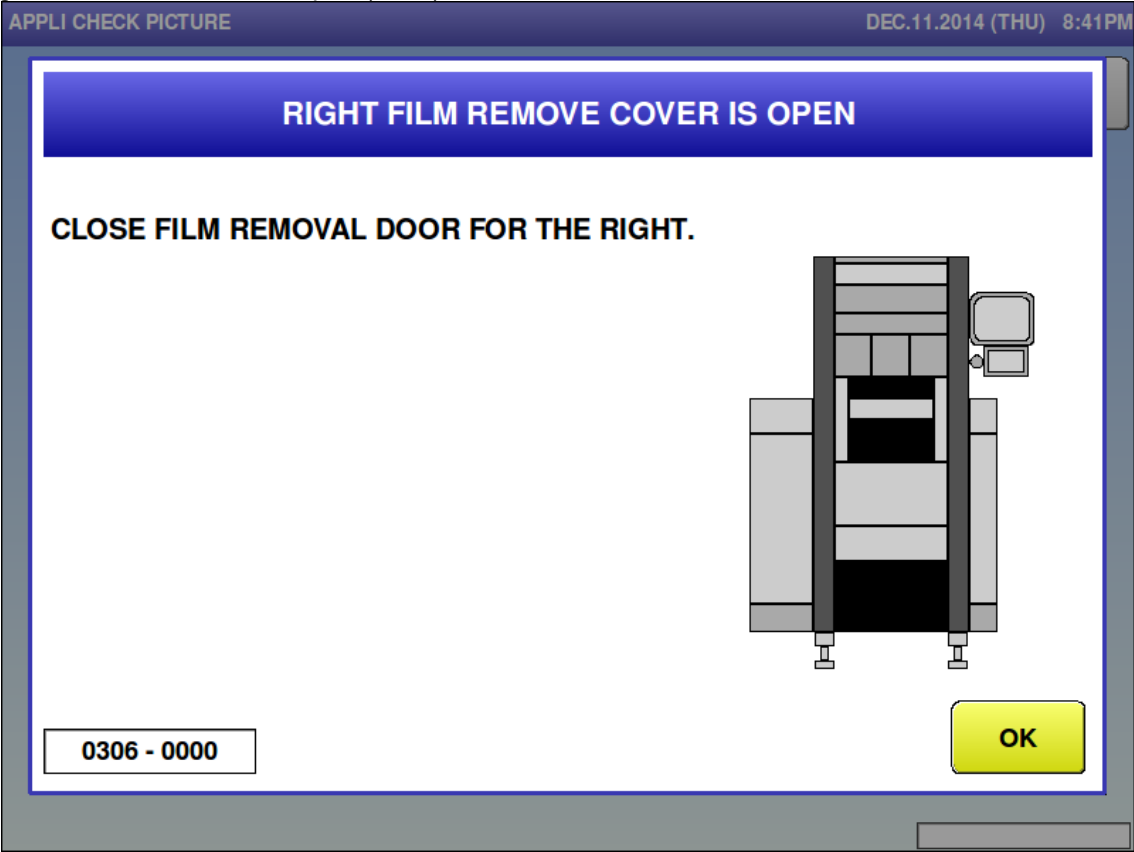

Error content	Right film remove cover is open.
Detail	Occurs when the right film remove cover is open before operation.
Solution	Close Right film remove cover, [OK] button.
Action by user	Close the film removal door on the right.
Action by service representative	Close the film removal door on the right.
Related part	Main board, wrapping machine board
Remarks	

■ Left film remove cover is open (0307)

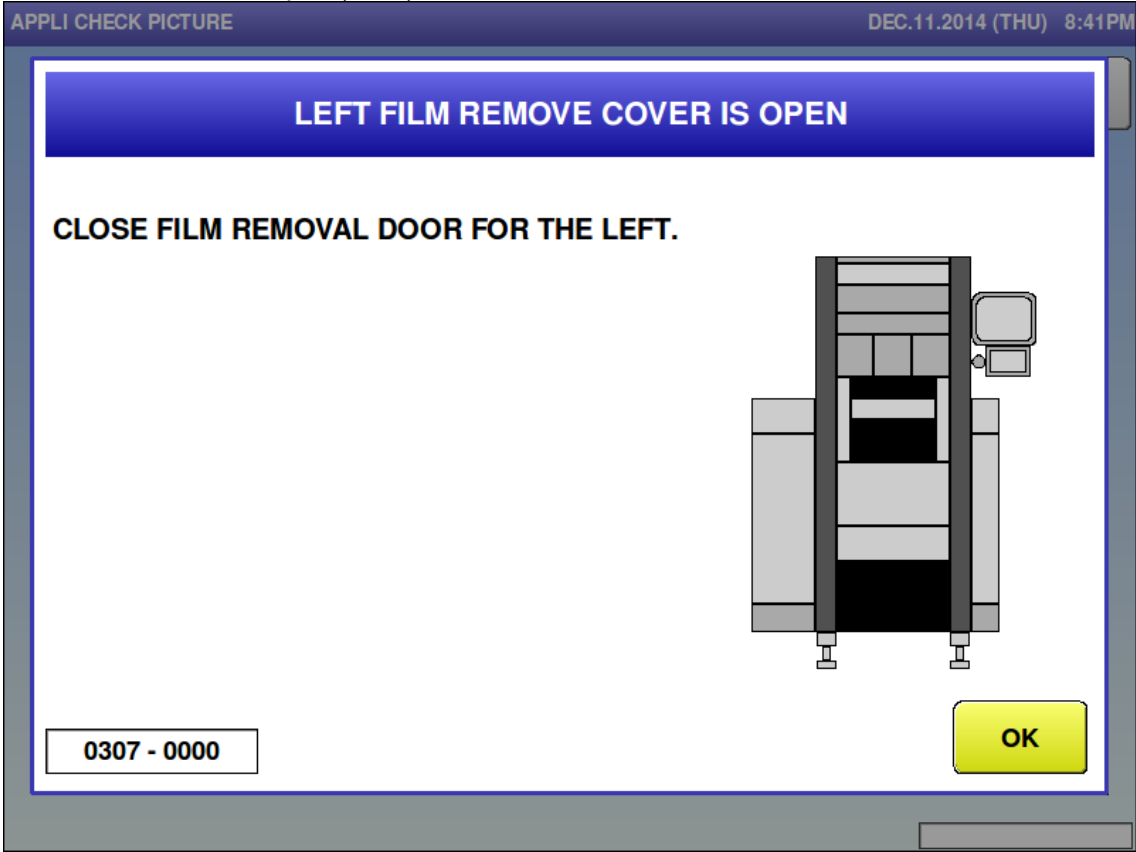

Error content	Left film remove cover is open.
Detail	Occurs when the left film remove cover is open before operation.
Solution	Close left film remove cover, [OK] button.
Action by user	Close the film removal door on the left.
Action by service representative	Close the film removal door on the left.
Related part	Main board, wrapping machine board
Remarks	

■ Left film exchange cover is open (0309)

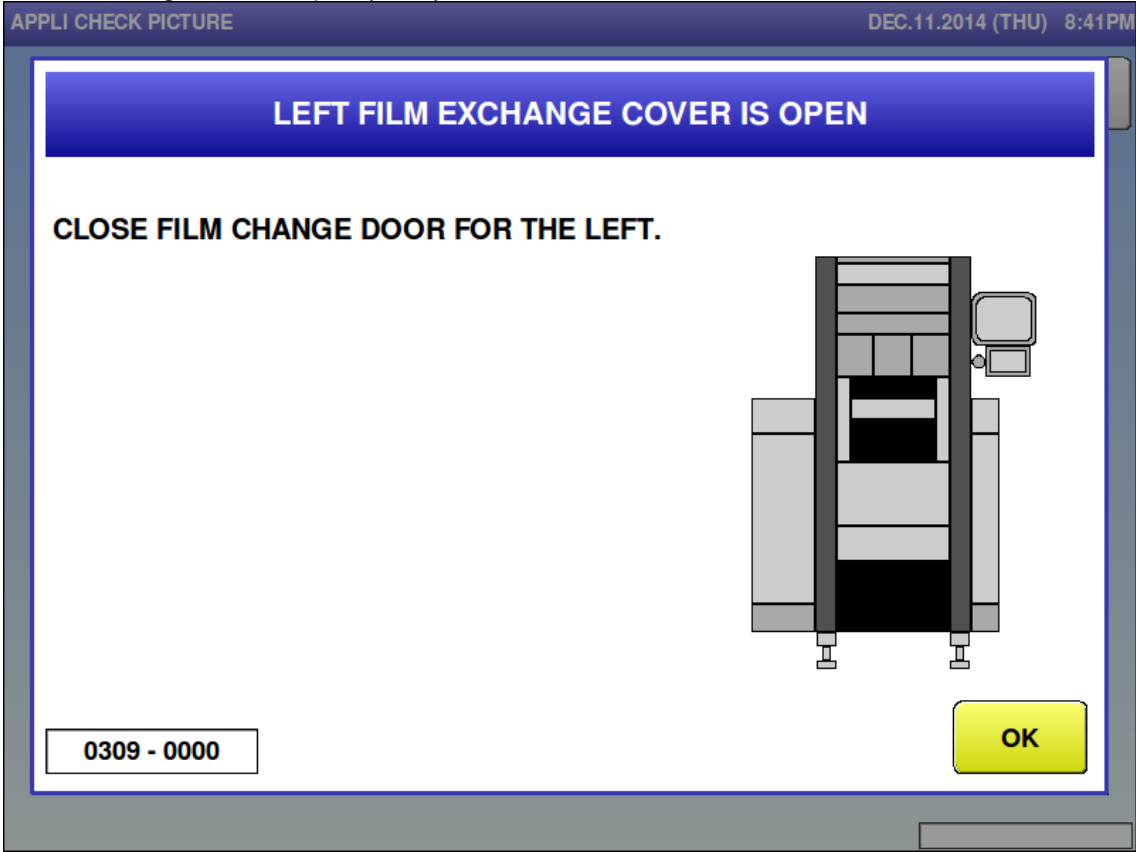

Error content	Left film exchange cover is open.
Detail	Occurs when the left film exchange cover is open before operation.
Solution	Close left film exchange cover, [OK] button.
Action by user	Close the film replacement door on the left.
Action by service representative	Close the film replacement door on the left.
Related part	Main board, wrapping machine board
Remarks	

■ Bracket for camera is up (0310)

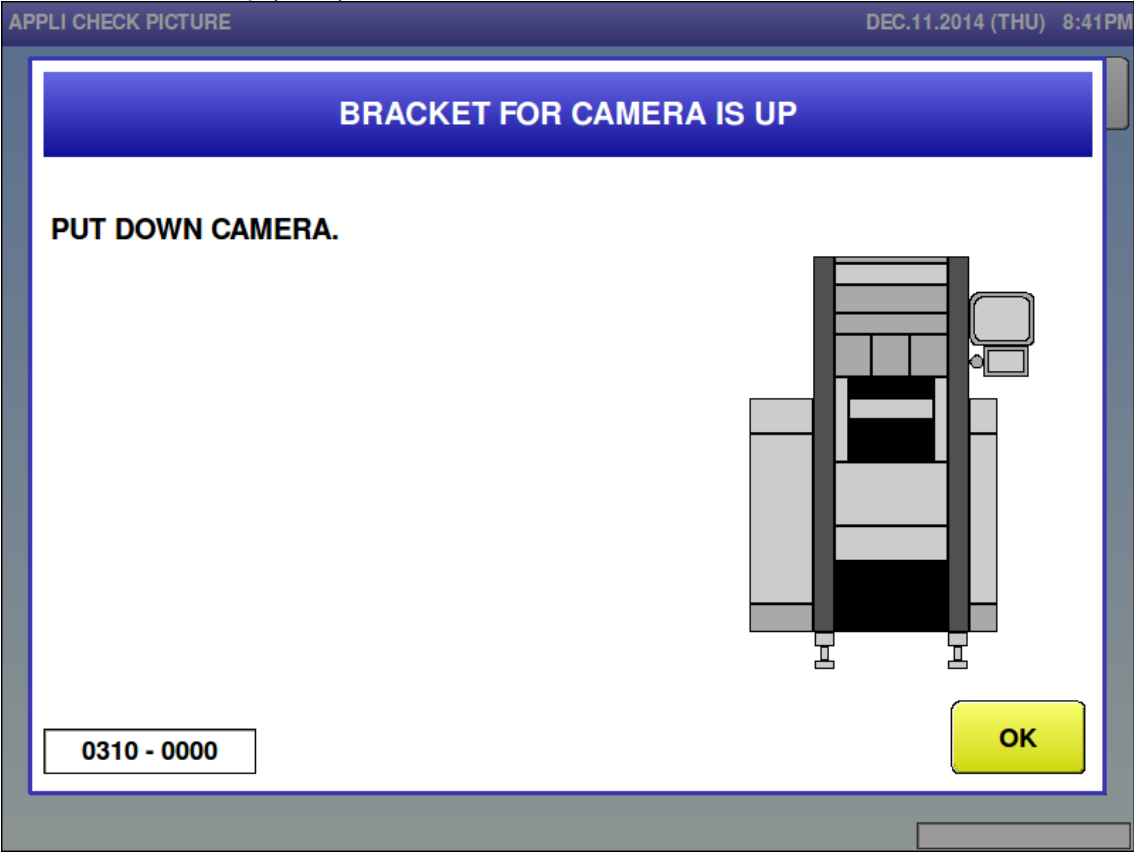

Error content	Bracket for camera is up.
Detail	Camera is pushed up when production.
Solution	Back the camera to the original position, [OK] button.
Action by user	Put the camera back to the original position. Press the [OK] button
Action by service representative	Put the camera back to the original position.
Related part	Main board, wrapping machine board
Remarks	

■ Label is remaining (0312)

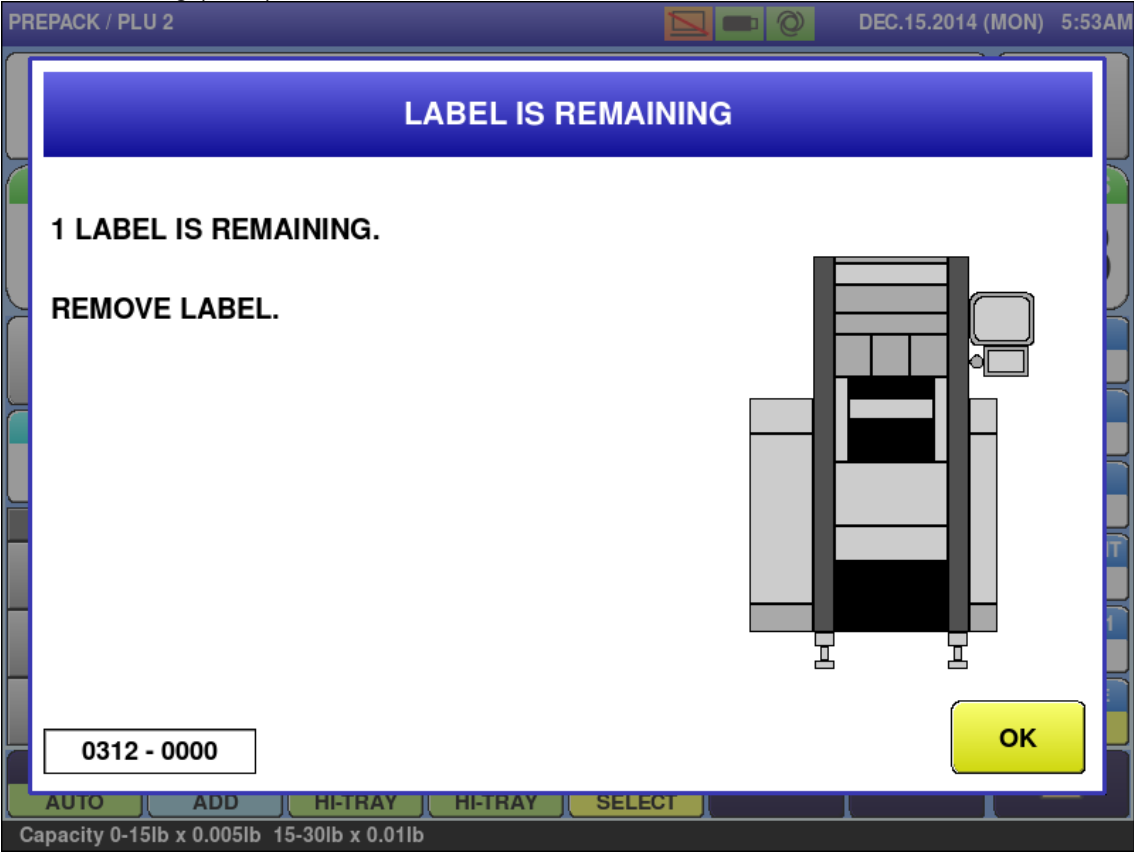

Error content	Label is remaining.
Detail	Separated by sub-error No. 0000: Printer
Solution	Remove label, [OK] button.
Action by user	Remove the label of the printer.
Action by service representative	Confirm the peel sensor operation of the printer on which an error occurred.
Related part	Main board, printer board
Remarks	

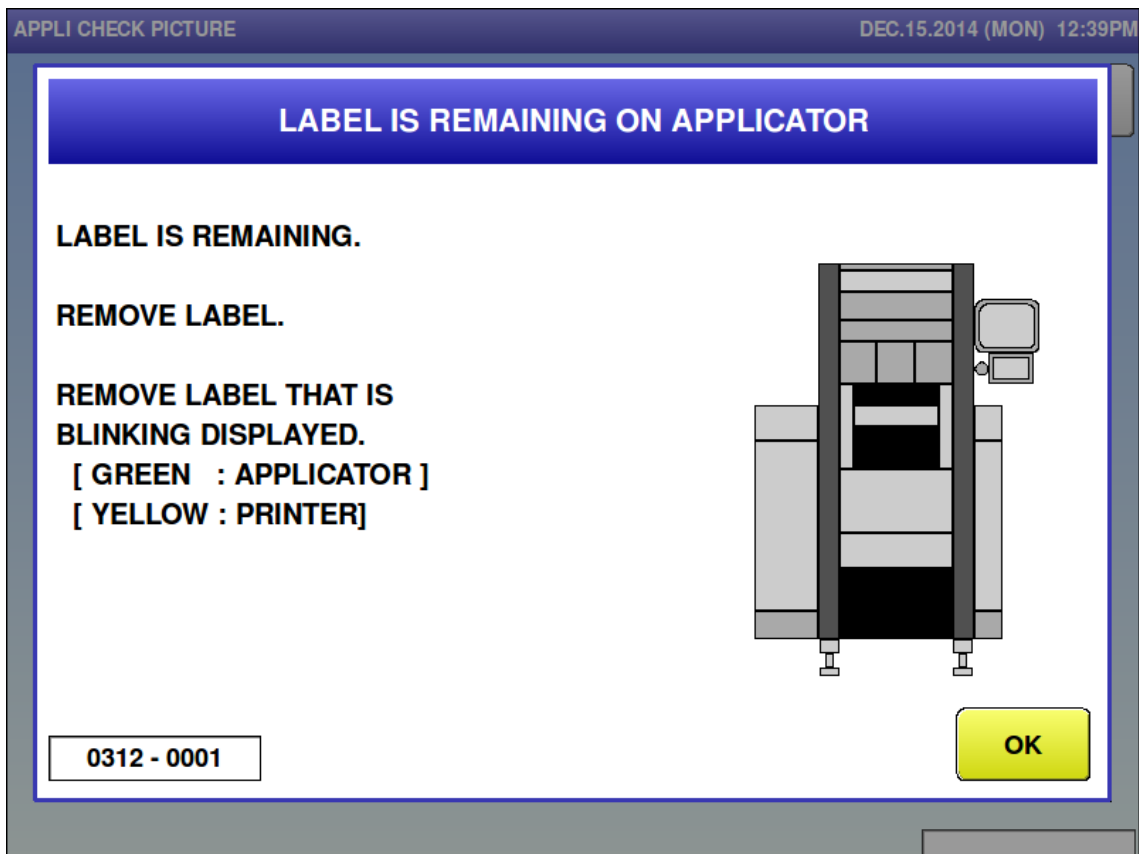

Error content	Label is remaining on applicator.
Detail	Separated by sub-error No. 0001: Applicator
Solution	Remove the label on applicator, [OK] button.
Action by user	Remove the label of the printer.
Action by service representative	Confirm the operation of the printer sensor.
Related part	Main board, wrapping machine board
Remarks	

■ Printer thermal head is up (0313)

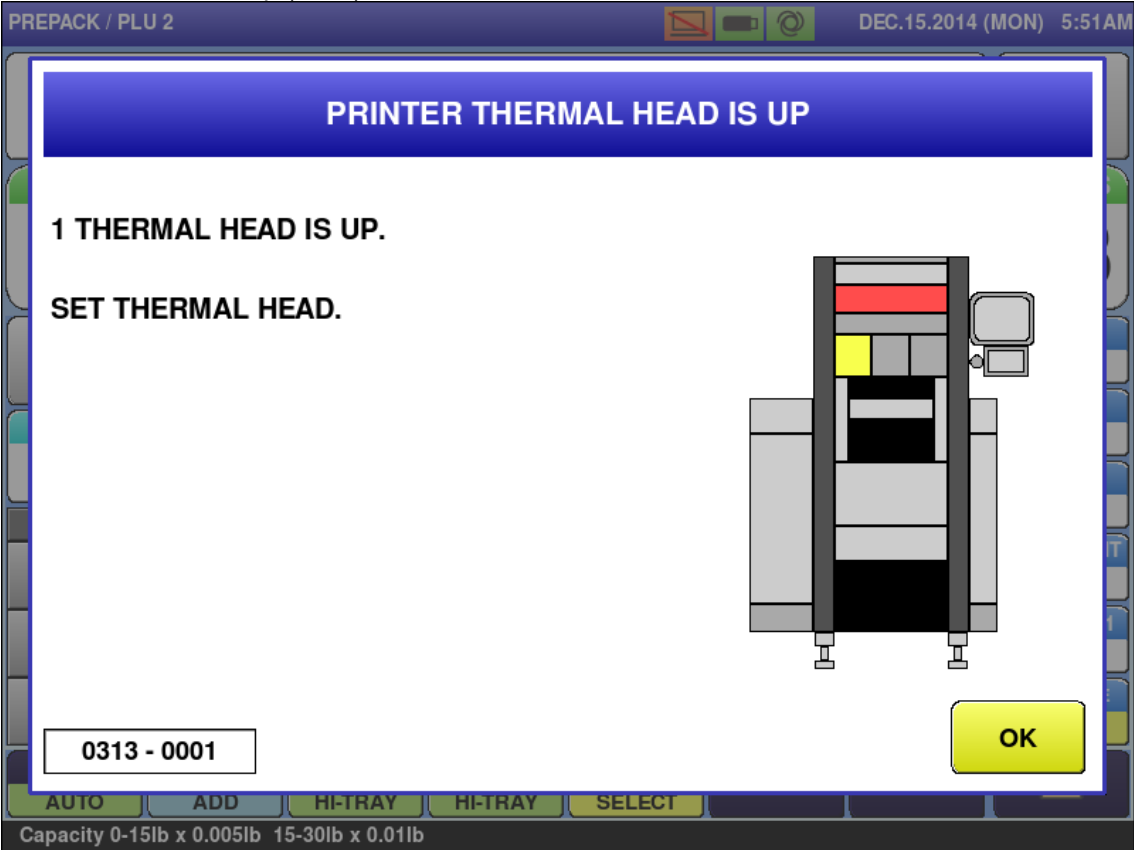

Error content	Printer thermal head is up.
Detail	Separated by sub-error No. 0001: WM-AI
Solution	Set thermal head, [OK] button.
Action by user	Set the thermal head.
Action by service representative	Confirm the thermal head sensor.
Related part	Main board, printer board
Remarks	

■ Products are stuck on the stock conveyor (0315)

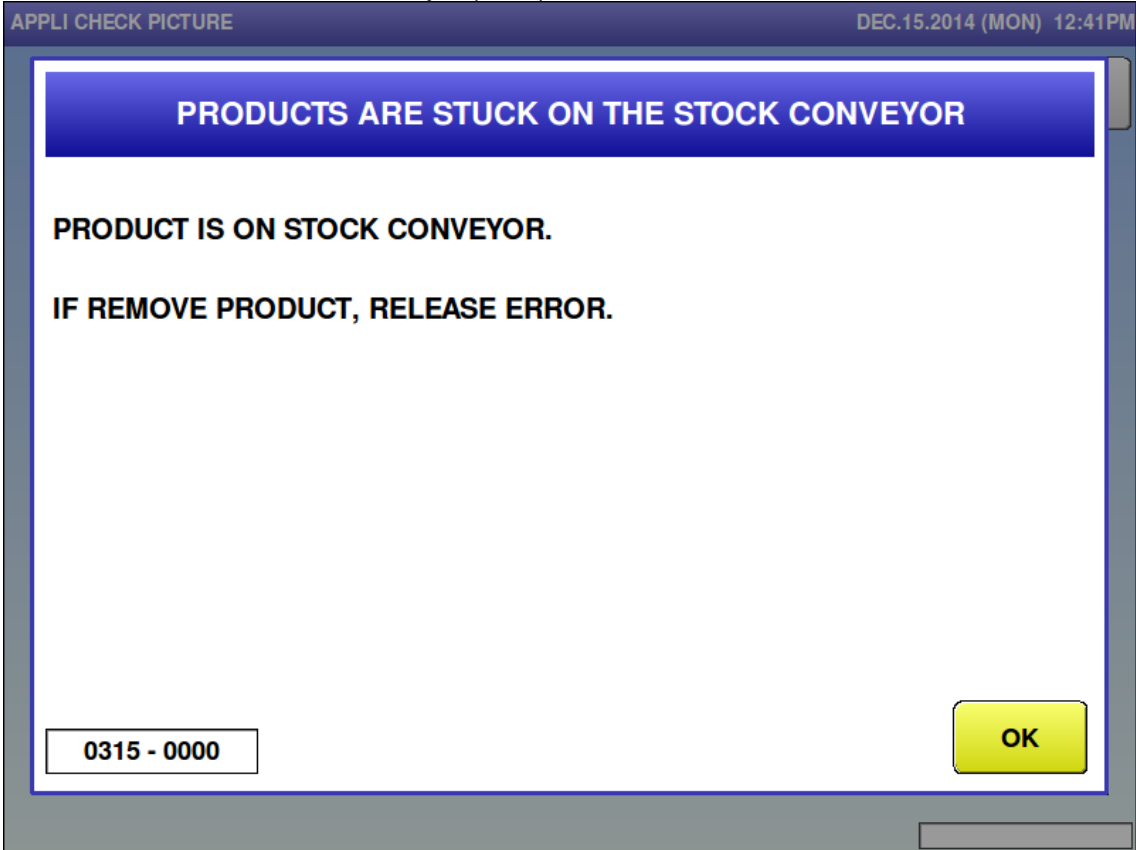

Error content	Products are stuck on the stock conveyor.
Detail	Occurs while the product blocks the full sensor from light when products remain on the discharge conveyor.
Solution	[OK] button, remove products on stock conveyor.
Action by user	Remove the product on the stock conveyor. * The error is cleared when the product is removed.
Action by service representative	Confirm the operation of the full sensor.
Related part	Main board, wrapping machine board
Remarks	Sensor calibration - Remove the cover under the sensor. - Potentiometer is accessed from the left through a hole in the frame using a long thin screwdriver. - The pot is a 10-turn type. The optimal setting is in the center (5 turns).

- Mark down price is more than original price (0316)

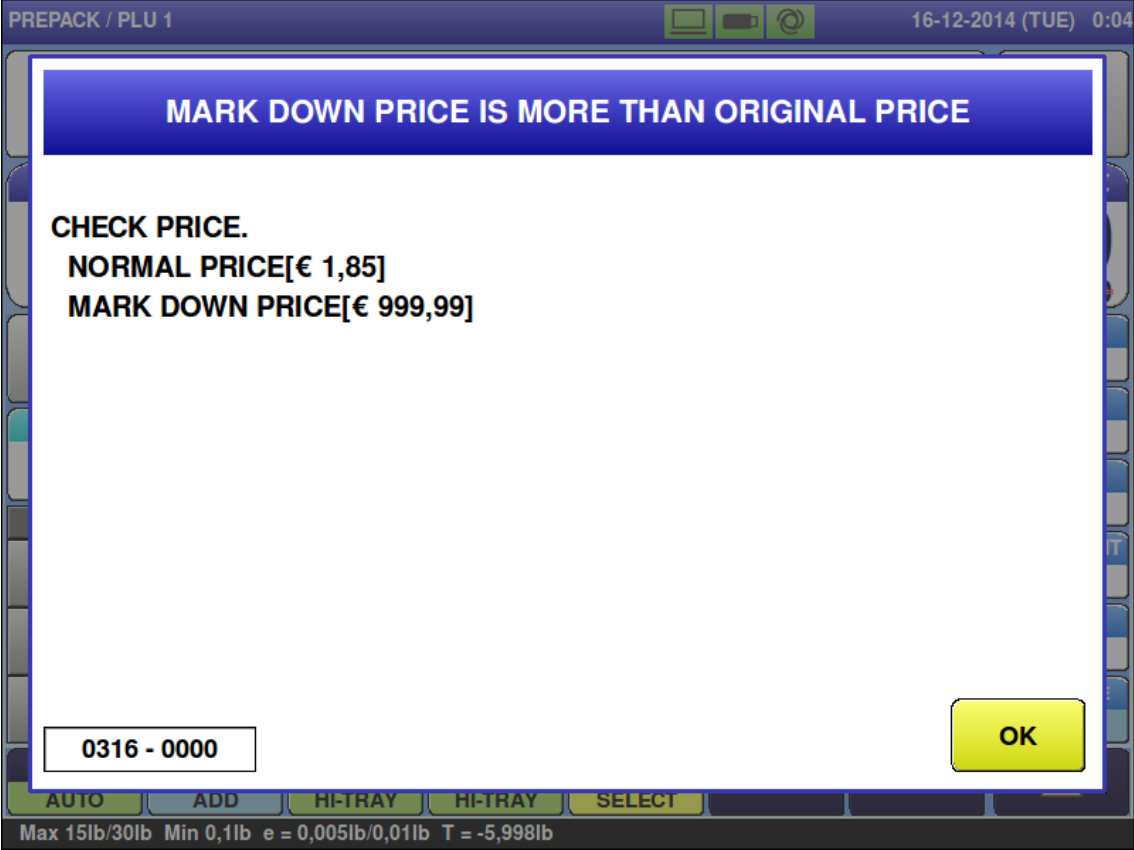

Error content	Mark down price is more than original price.
Detail	
Solution	[OK] button
Action by user	Change the mark down price. * Set the mark down price lower than the original price.
Action by service representative	Change the mark down price. Confirm the product master. Confirm the host product master when linked with the host system.
Related part	Main board
Remarks	Original price and markdown price are displayed.

- Mark down unit price is more than original price (0318)

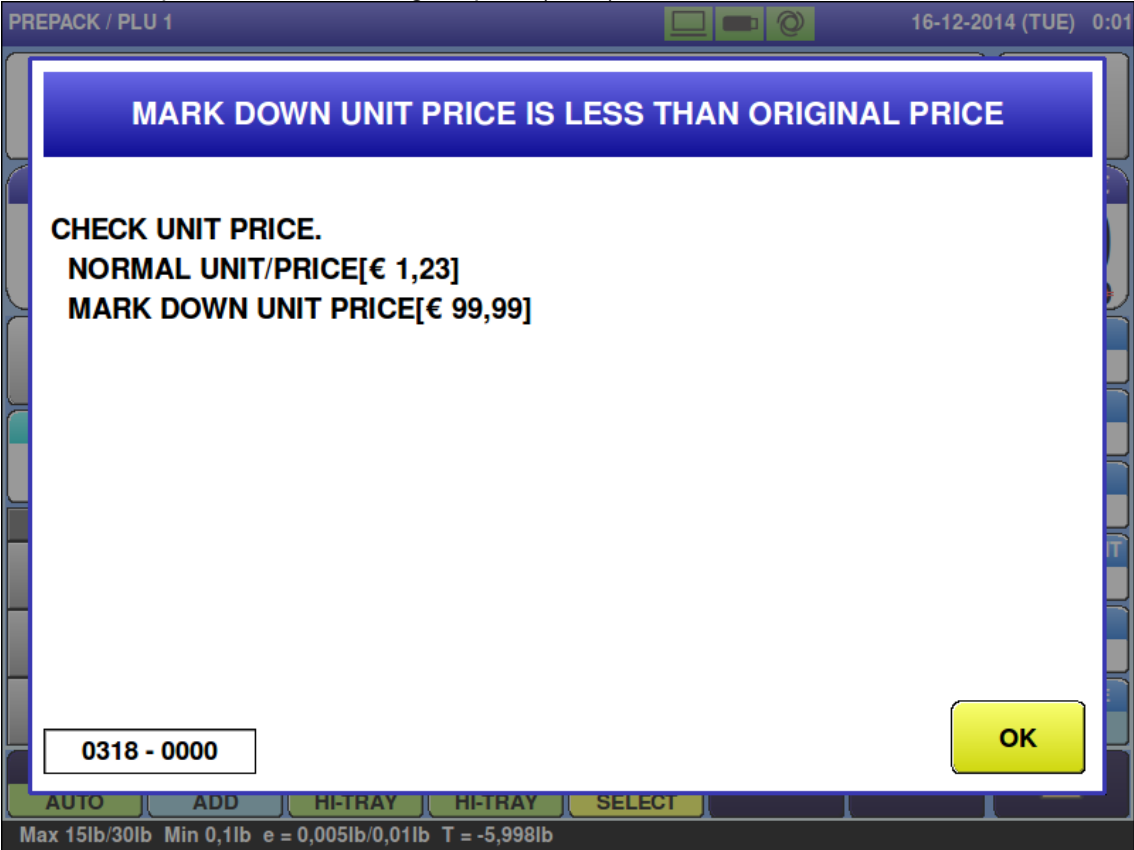

Error content	Mark down unit price is less than original price.
Detail	
Solution	[OK] button
Action by user	Change the mark down price. * Set the mark down price lower than the original price.
Action by service representative	Change the mark down price. Confirm the product master. Confirm the host product master when linked with the host system.
Related part	Main board
Remarks	Original price and markdown unit price are displayed.

■ Production for target is completed (0319)

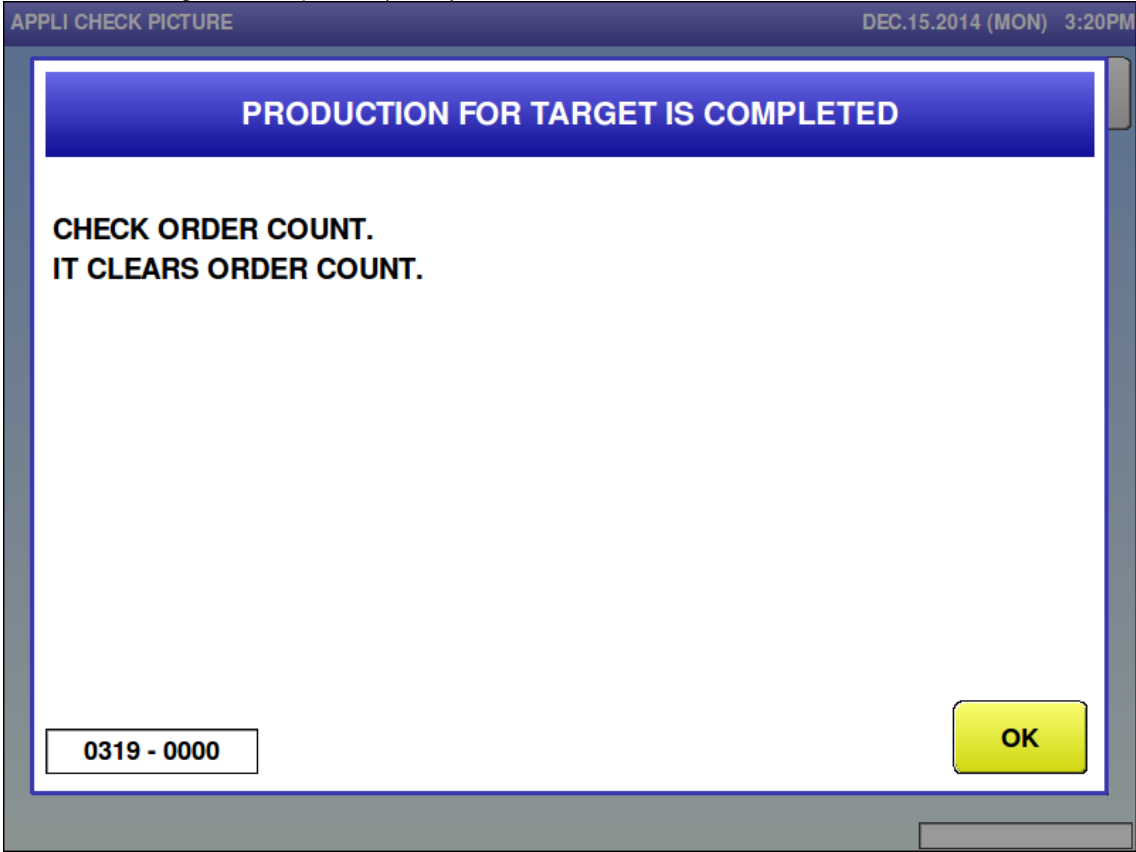

Error content	Production exceeding order count is attempted.
Detail	
Solution	[OK] button
Action by user	Press the [OK] button. Continue production after releasing the error.
Action by service representative	Press the [OK] button.
Related part	Main board
Remarks	Clears order count.

■ Price is not programmed (0321)



Error content	Price is not programmed.
Detail	
Solution	[OK] button
Action by user	Enter the price. Confirm the product master.
Action by service representative	Enter the price. Confirm the product master. Confirm the host product master when linked with the host system.
Related part	Main board
Remarks	Does not occur when [Do not display] is selected for 0 price error.

■ Go back to original position (0322)

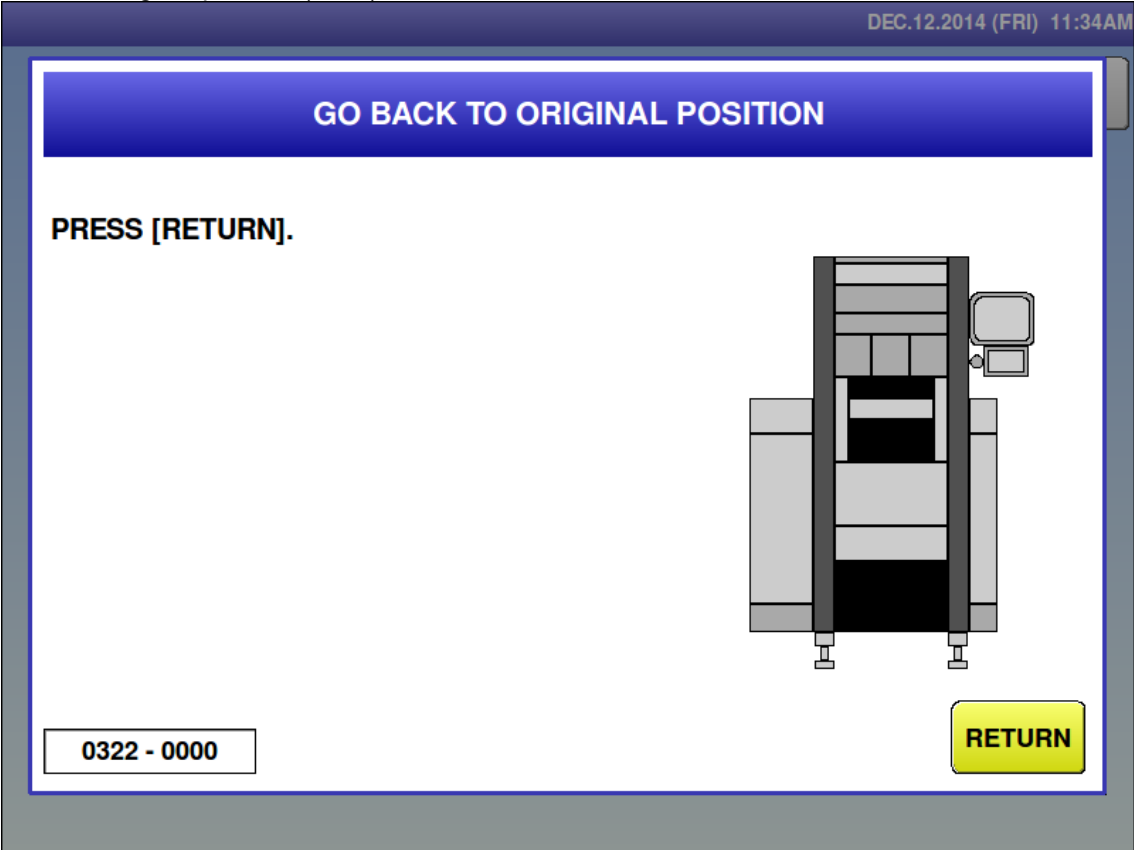

Error content	Go back to original position.
Detail	
Solution	[RETURN] button
Action by user	Press the[RETURN] button.
Action by service representative	Press the[RETURN] button.
Related part	Main board, wrapping machine board
Remarks	<ul style="list-style-type: none"> ▪ Origin position return processing is performed by pressing the [RETURN] button. ▪ Only once after power is turned ON.

■ Weight is out of range (0325—0000)

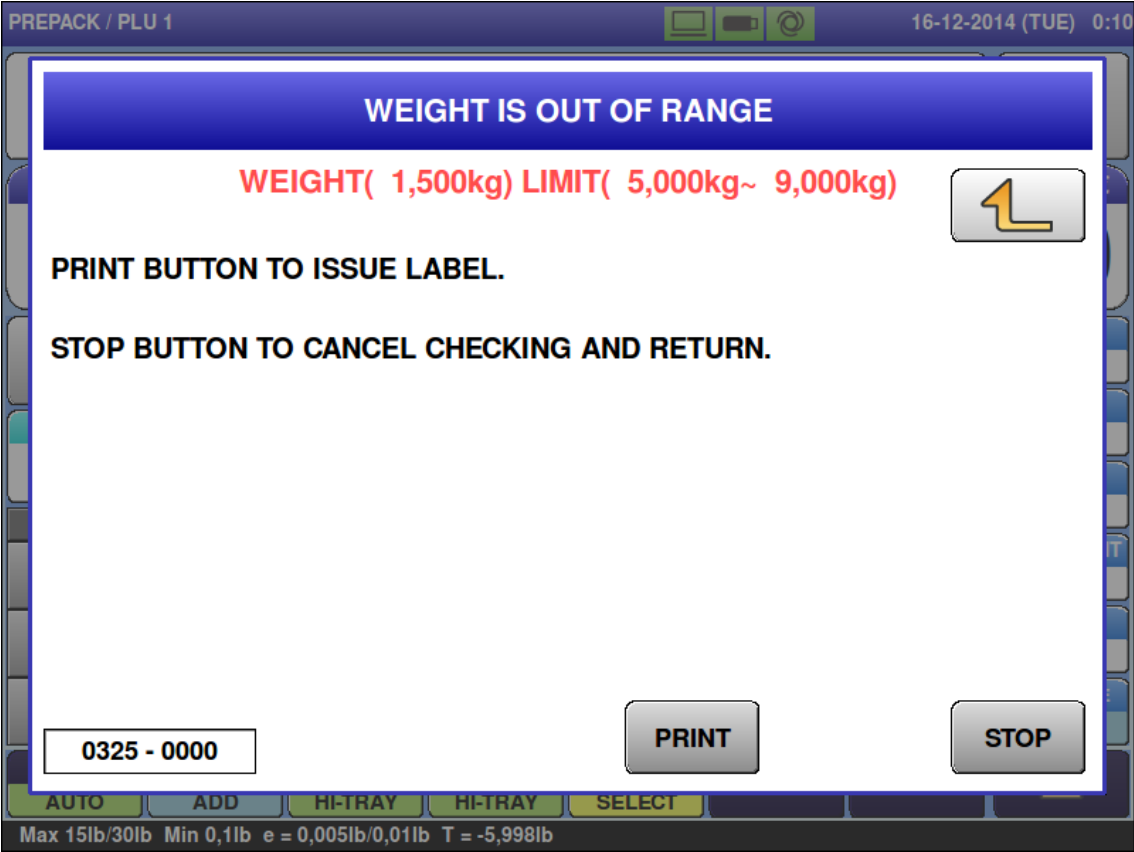

Error content	Weight is out of range.
Detail	Separated by sub-error No. 0000: weight out of range error
Solution	* When there is error because Weight is out of range. [PRINT] button: no error [STOP] button: will not check weight until next product is called. Numeric key: close the error screen.
Action by user	Increase the weight of the product. Confirm [Upper Limit Weight] and [Lower Limit Weight] of the product master.
Action by service representative	Confirm the product master. Confirm the host product master when linked with the host system.
Related part	Main board
Remarks	Does not check product limits when [No] is selected for product weight measurement in system data settings.

■ Weight is out of range (0325—0001)

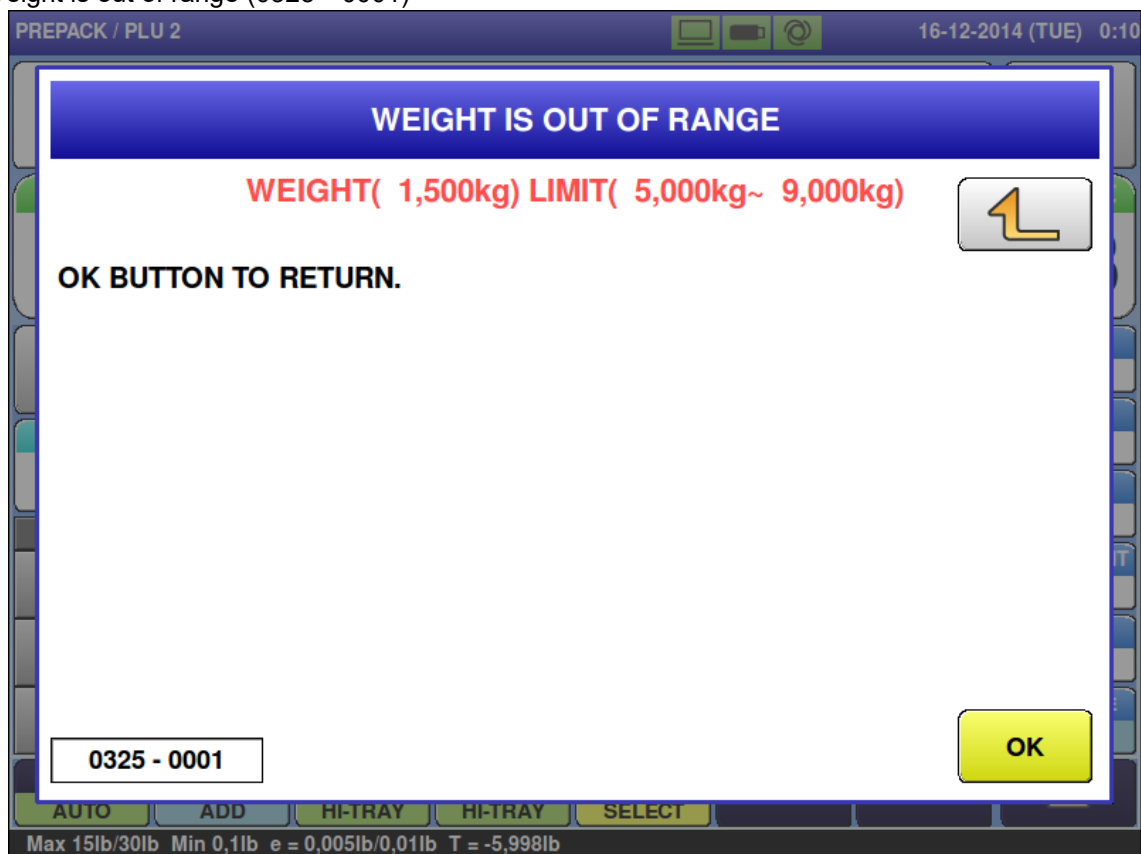

Error content	Weight is out of range.
Detail	Separated by sub-error No. 0001: weight out of range error
Solution	[OK] button
Action by user	Increase the weight of the product. Confirm [Upper Limit Weight] and [Lower Limit Weight] of the product master.
Action by service representative	Confirm the product master. Confirm the host product master when linked with the host system.
Related part	Main board
Remarks	Does not check product limits when [No] is selected for product weight measurement in system data settings.

■ It cannot detect tray (0326)

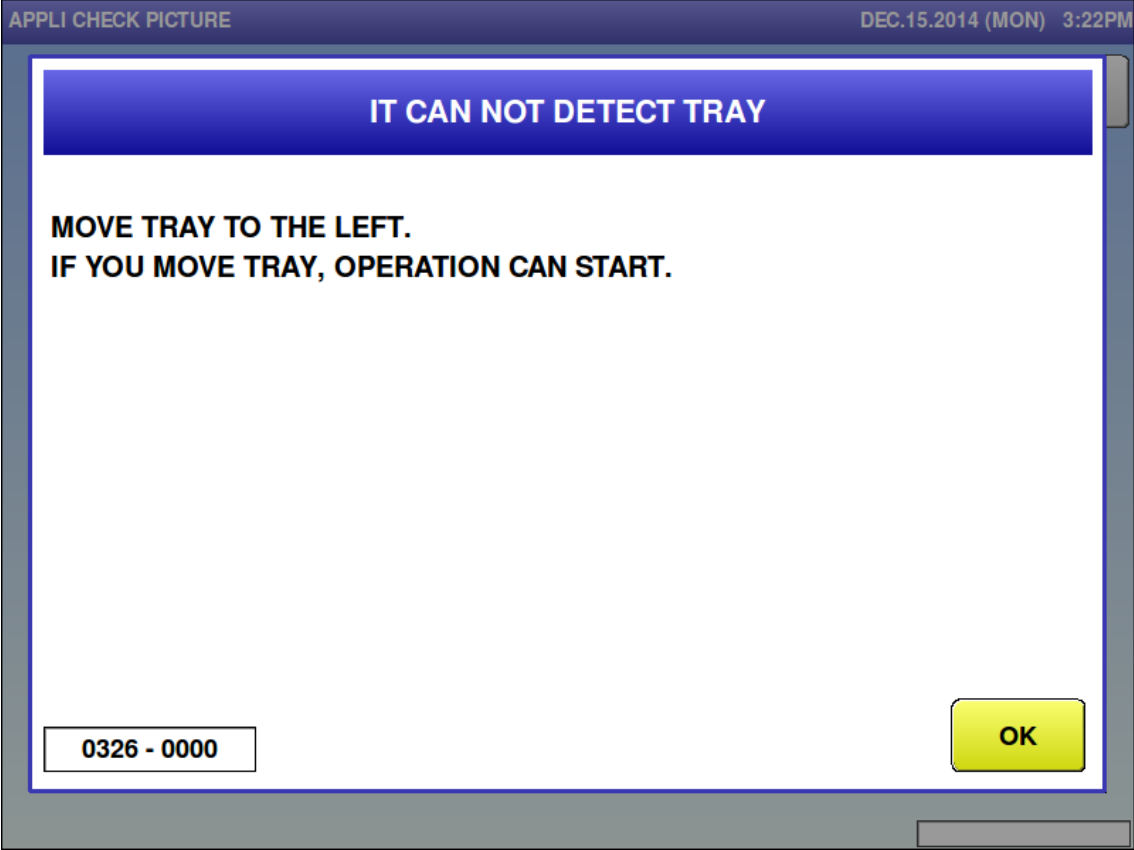

Error content	Tray detection error.
Detail	The right side of the tray is protruding.
Solution	Fix tray placement, [OK] button
Action by user	Place the tray in the center again.
Action by service representative	Place the tray in the center again. Confirm the camera detection.
Related part	Main board, detection board
Remarks	

■ It cannot detect tray (0327)

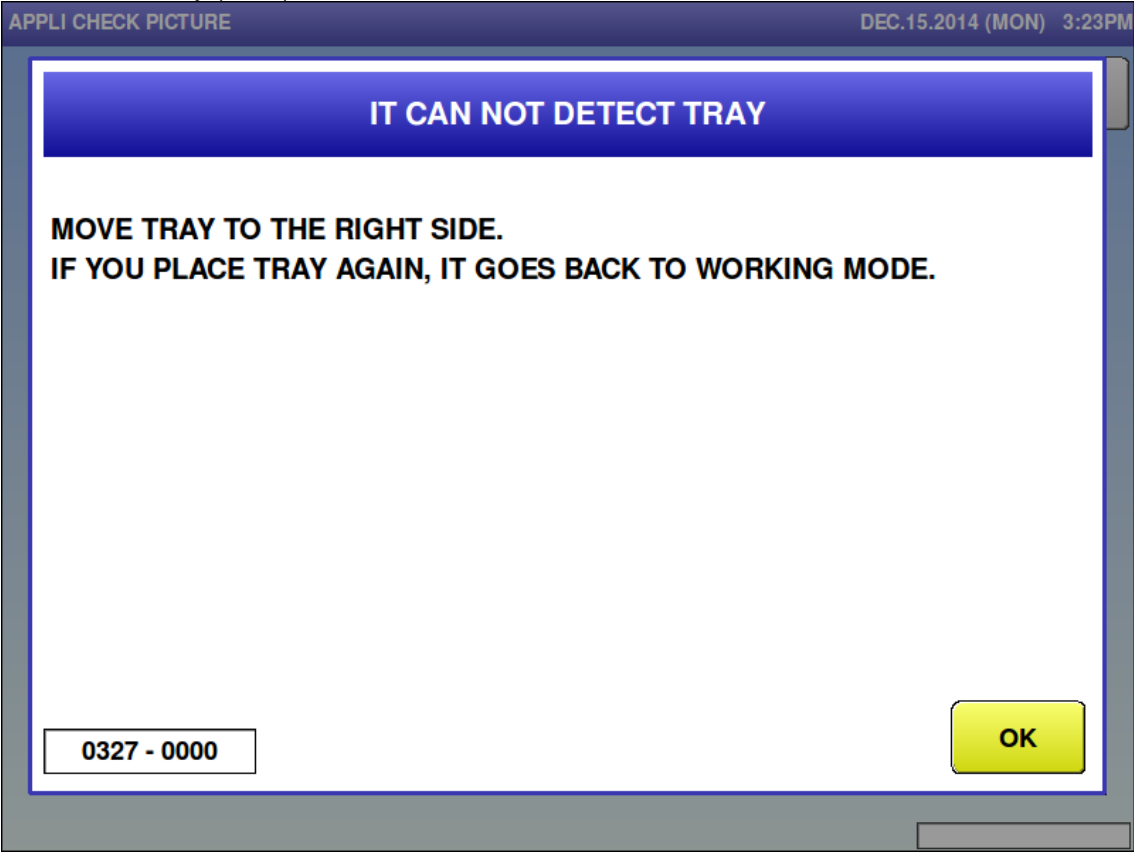

Error content	Tray detection error.
Detail	The left side of the tray is protruding.
Solution	Fix tray placement, [OK] button
Action by user	Place the tray in the center again.
Action by service representative	Place the tray in the center again. Confirm the camera detection.
Related part	Main board, detection board
Remarks	

- It cannot differentiate tray (0328)

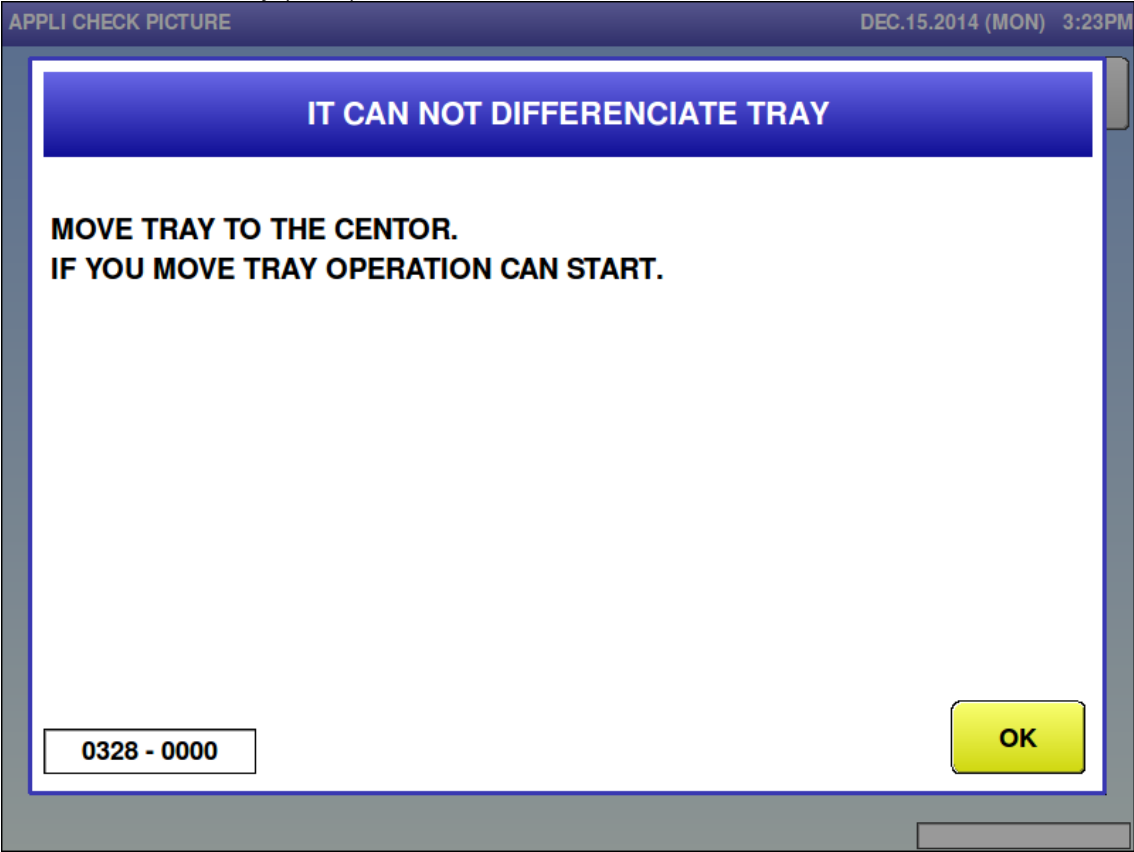

Error content	Tray detection error.
Detail	Right and left sides of the tray are protruding. Lower side of the tray is protruding. Sub-error 0001 data abnormally
Solution	Fix tray placement, [OK] button
Action by user	Place the tray in the center again.
Action by service representative	Place the tray in the center again. Confirm the camera detection.
Related part	Main board, detection board
Remarks	

■ It cannot differentiate tray (0333)

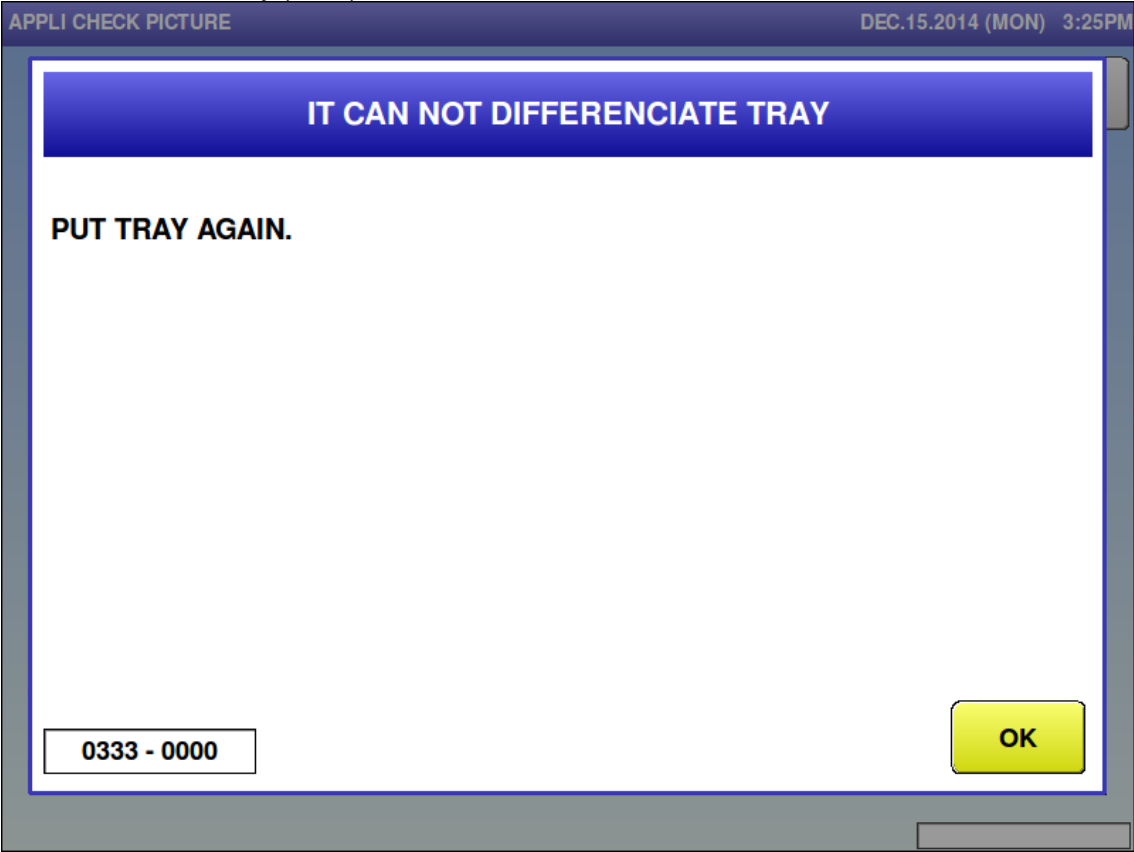

Error content	Tray detection error.
Detail	Tray in size as detected by detector is not registered in master
Solution	Fix tray placement, [OK] button
Action by user	Place the tray in the center again.
Action by service representative	Place the tray in the center again. Confirm the camera detection.
Related part	Main board, detection board
Remarks	

■ Tray is not programmed (0334)

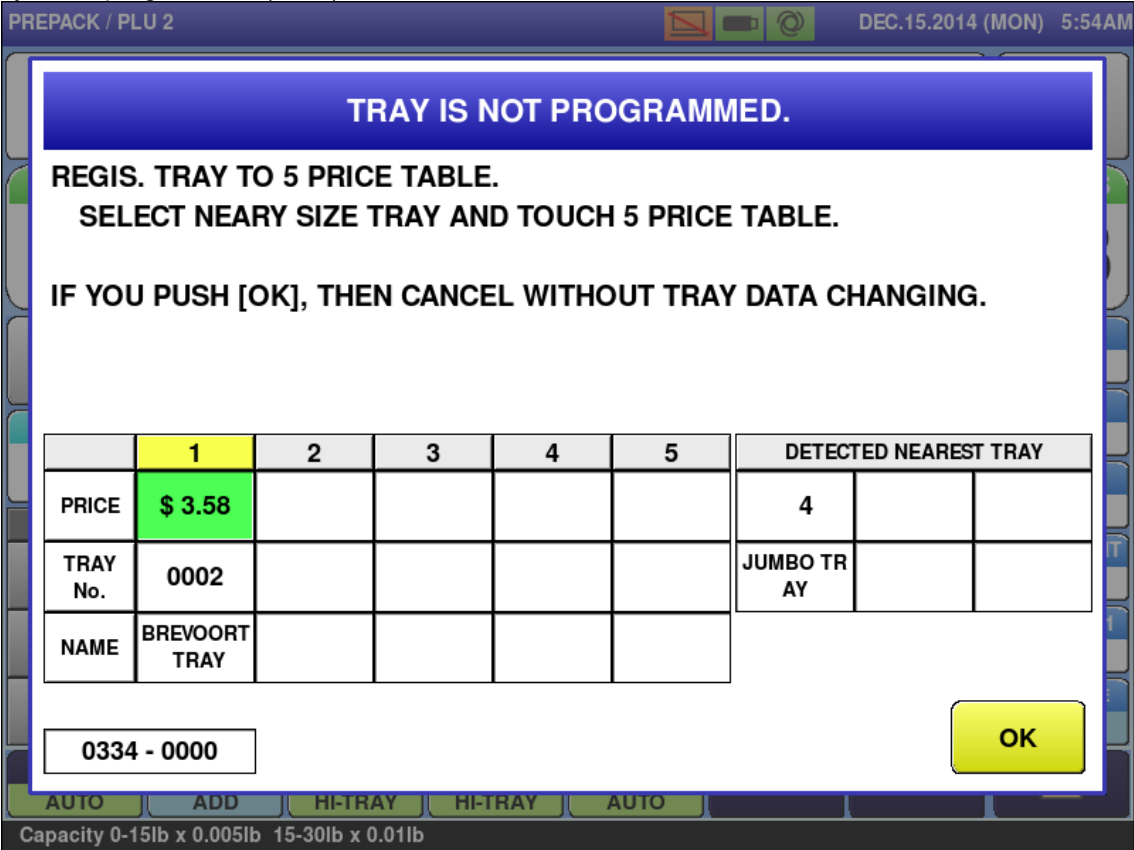

Error content	Tray is not programmed in the 5 price table. Similar tray in size is registered in the master.
Detail	
Solution	Register the tray in the 5 price table, [OK] button.
Action by user	Register the tray number that is used in the 5 price table. Confirm the product master.
Action by service representative	Confirm the product master. Confirm the host product master when linked with the host system.
Related part	Main board, detection board
Remarks	

■ Close tray is programmed (0335)

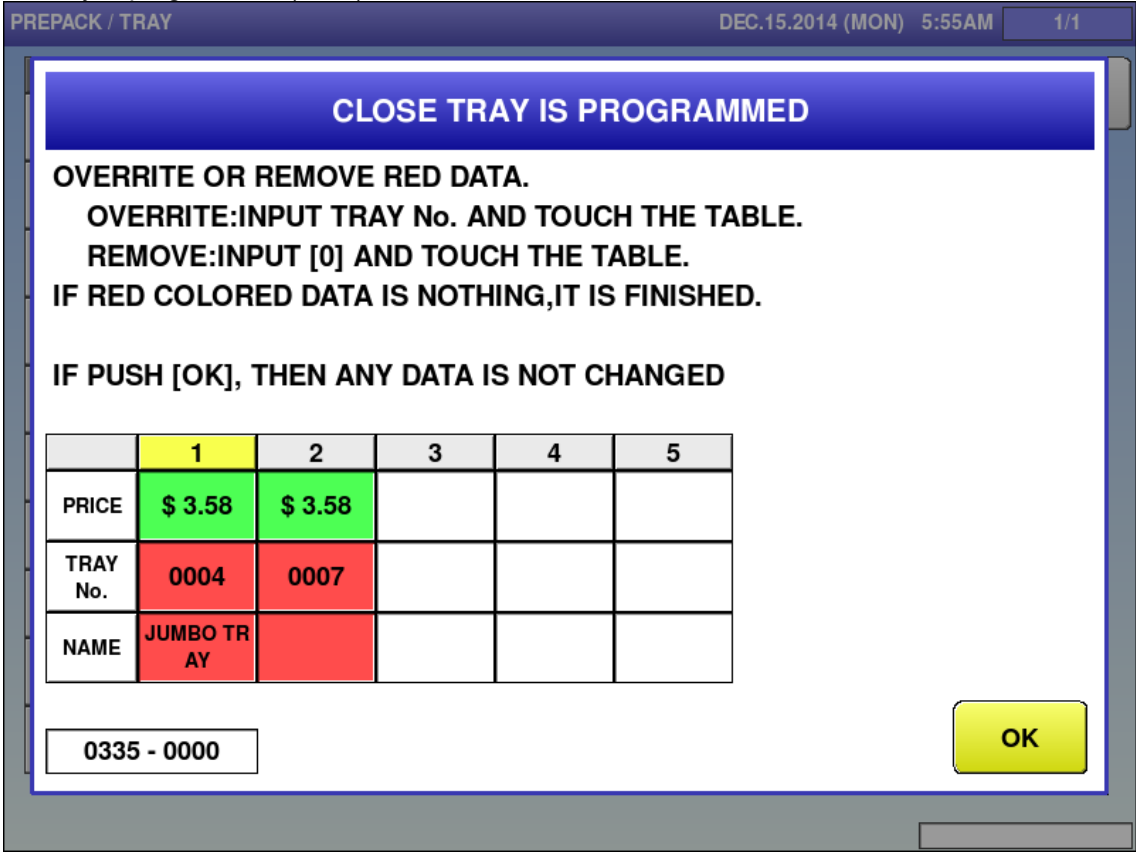

Error content	Similar tray in size is registered in the 5 price table.
Detail	Multiple trays exist in the 5 price table in system mode automatic tray recognition input limitation settings.
Solution	Delete similar tray, [OK] button.
Action by user	Delete the tray number that is not used in the 5 price table. Confirm the product master.
Action by service representative	Confirm the product master. Confirm the host product master when linked with the host system.
Related part	Main board, detection board
Remarks	

■ Completed production for order count (0336)

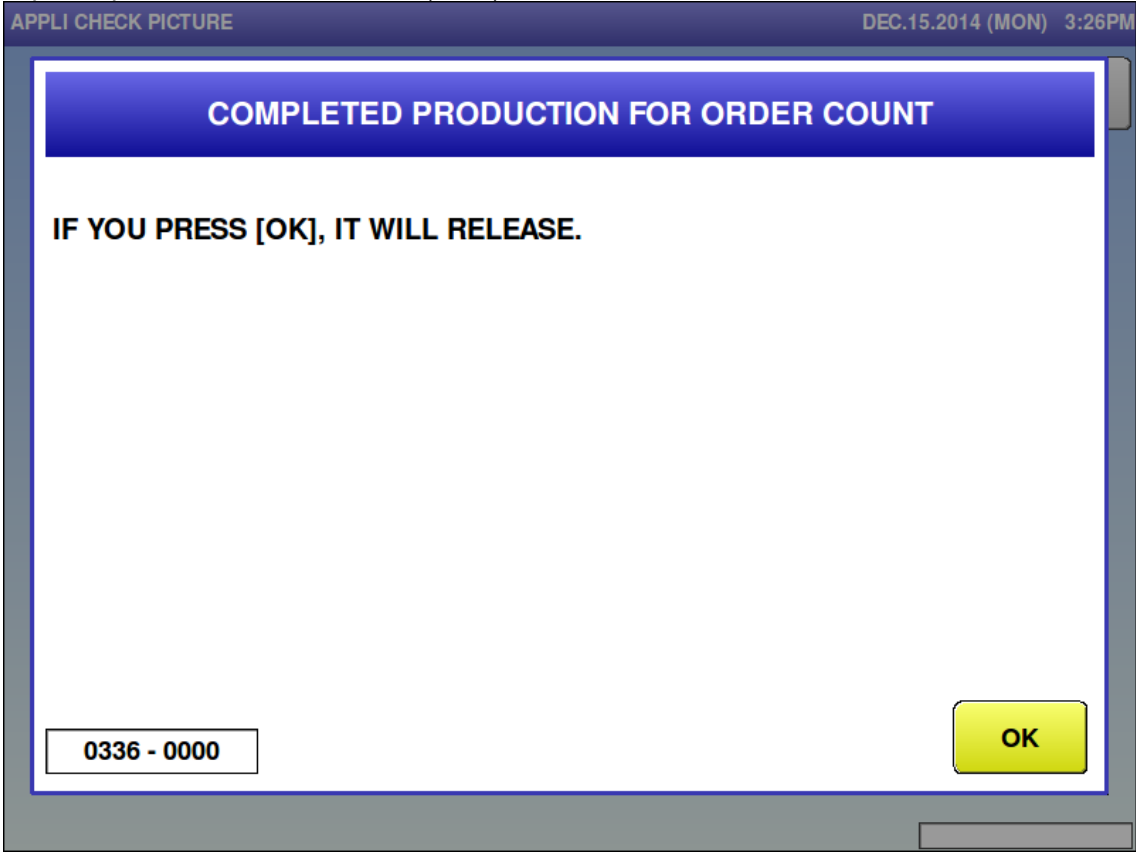

Error content	Order count has been completed.
Detail	
Solution	[OK] button
Action by user	Press the [OK] button.
Action by service representative	Press the [OK] button.
Related part	Main board
Remarks	Displayed when [End message] is selected in system data settings in system mode.

■ Order is deleted (0337)

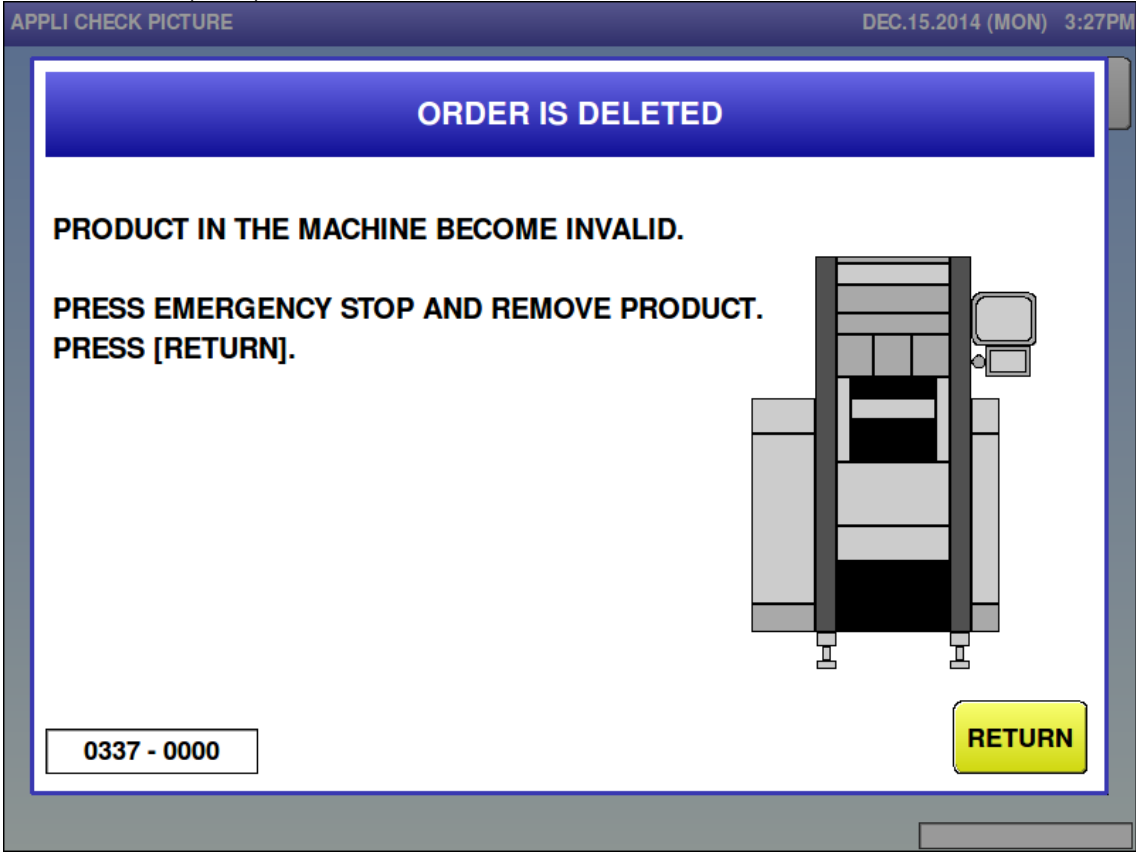

Error content	Data has been deleted.
Detail	
Solution	[RETURN] button.
Action by user	Press the emergency stop button, remove the product in the wrapper, and then press the [RETURN] button.
Action by service representative	Press the emergency stop button, remove the product in the wrapper, and then press the [RETURN] button.
Related part	Main board
Remarks	This screen is displayed when the products in the wrapper become invalid after data has been deleted.

■ Lower value is less than fixed weight (0339)

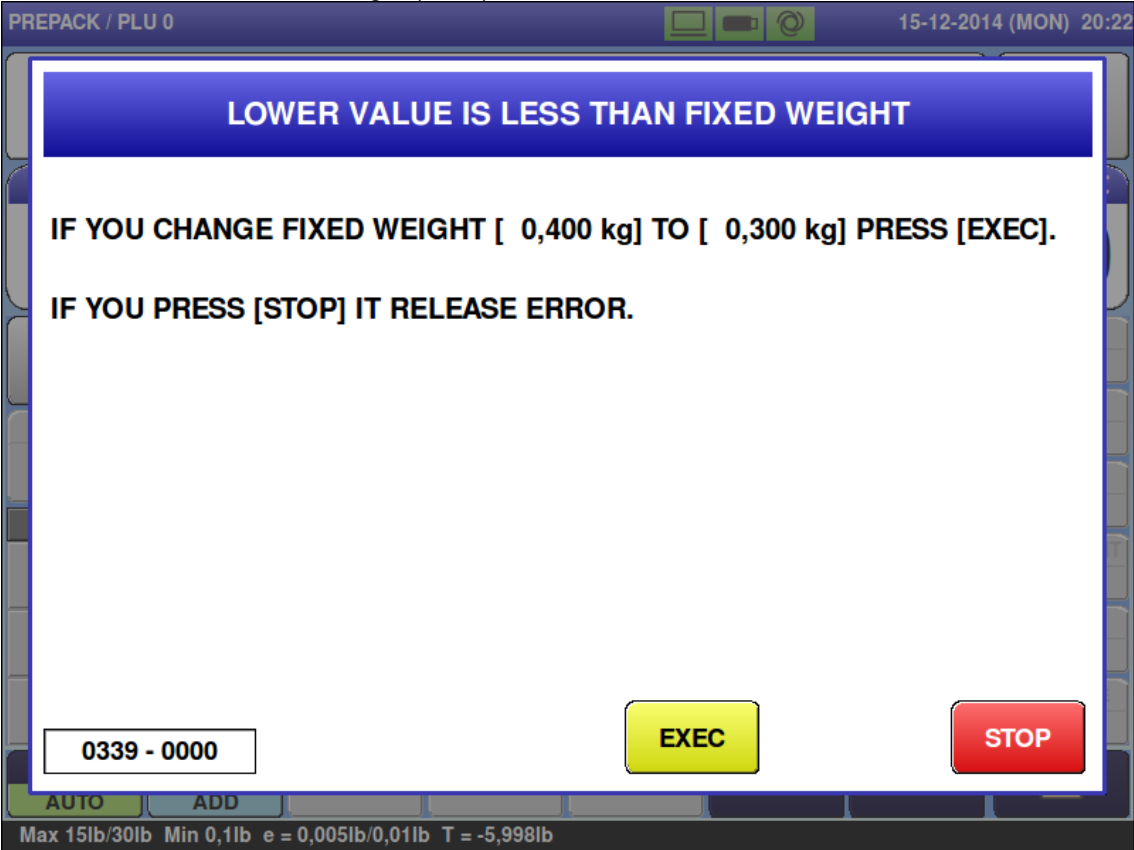

Error content	Lower value is less than fixed weight.
Detail	Attempted to enter a minimum value lighter than the fixed weight in fixed weight mode.
Solution	[EXEC] button => Set fixed weight to the minimum value. [STOP] button => Release error.
Action by user	Confirm [Fixed weight] and [Lower limit weight] of the product master.
Action by service representative	Confirm the product master. Confirm the host product master when linked with the host system.
Related part	Main board
Remarks	The minimum value will remain the same if the error is released.

■ Product is remaining on the lift (0341)

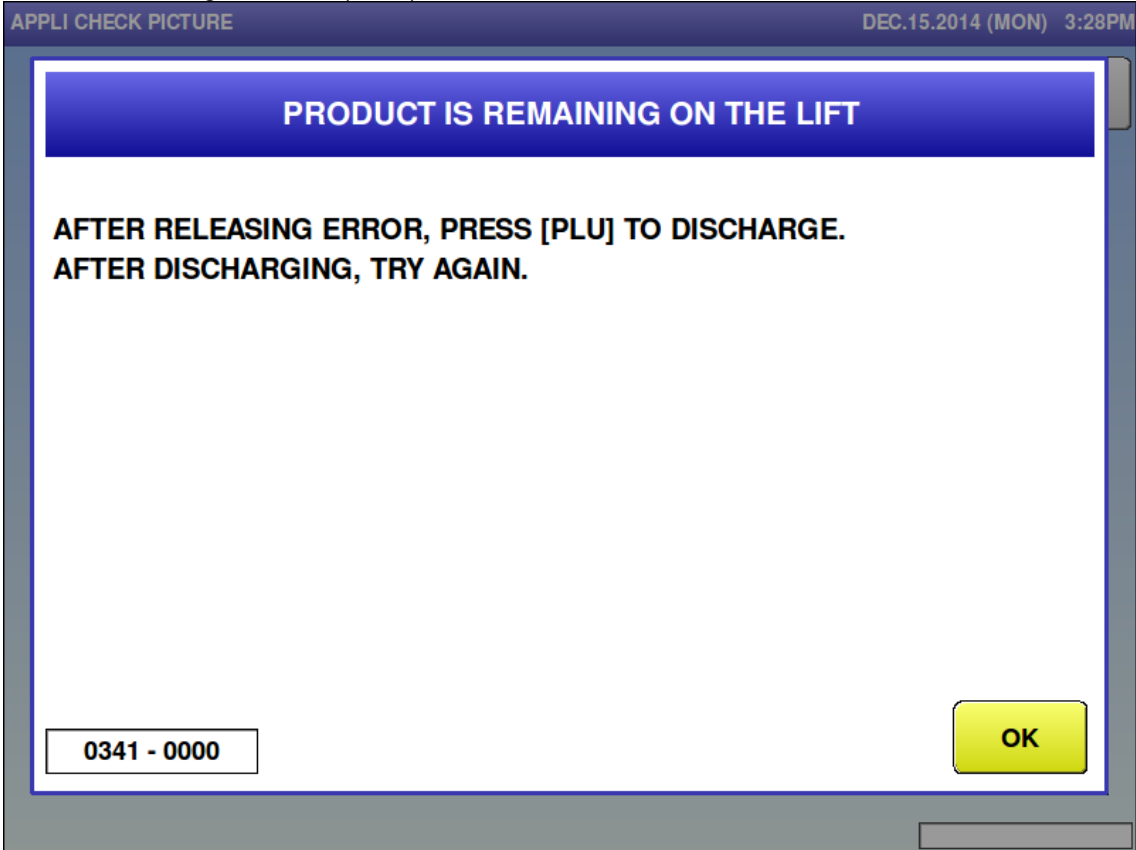

Error content	Product is remaining on the lift.
Detail	
Solution	[OK] button
Action by user	Press the [OK] button to release the error screen, press the [PLU] key to discharge the product on the lift.
Action by service representative	Press the [OK] button to release the error screen, press the [PLU] key to discharge the product on the lift.
Related part	Main board, wrapping machine board
Remarks	Press the [PLU] button and remove the product after releasing the error.

■ POS code is not programmed (0342)

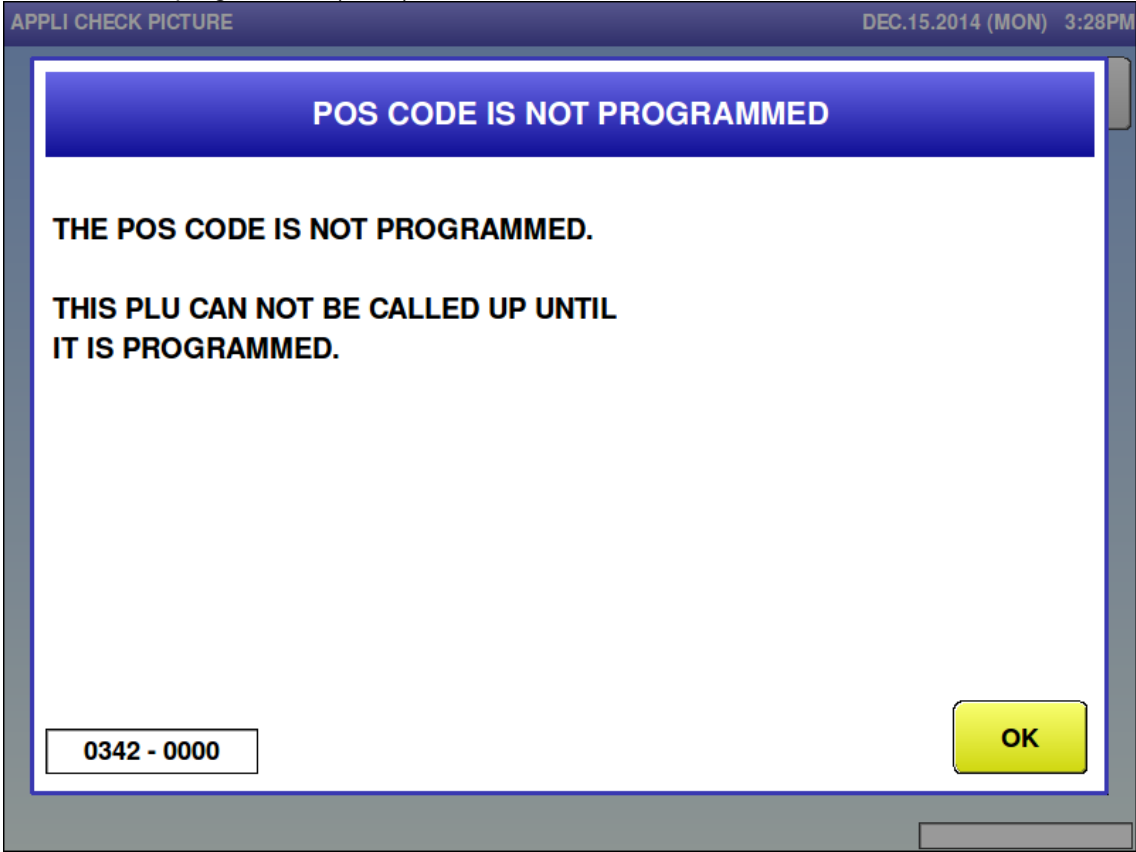

Error content	POS code is not programmed.
Detail	
Solution	[OK] button
Action by user	On the [Register: Product] screen, enter "POS code" of the target product.
Action by service representative	Confirm the product master. Confirm the host product master when linked with the host system.
Related part	Main board
Remarks	* Occurs when [POS code unregistered error] is set. *Labels cannot be issued.

■ Tray no. is not programmed (0350)

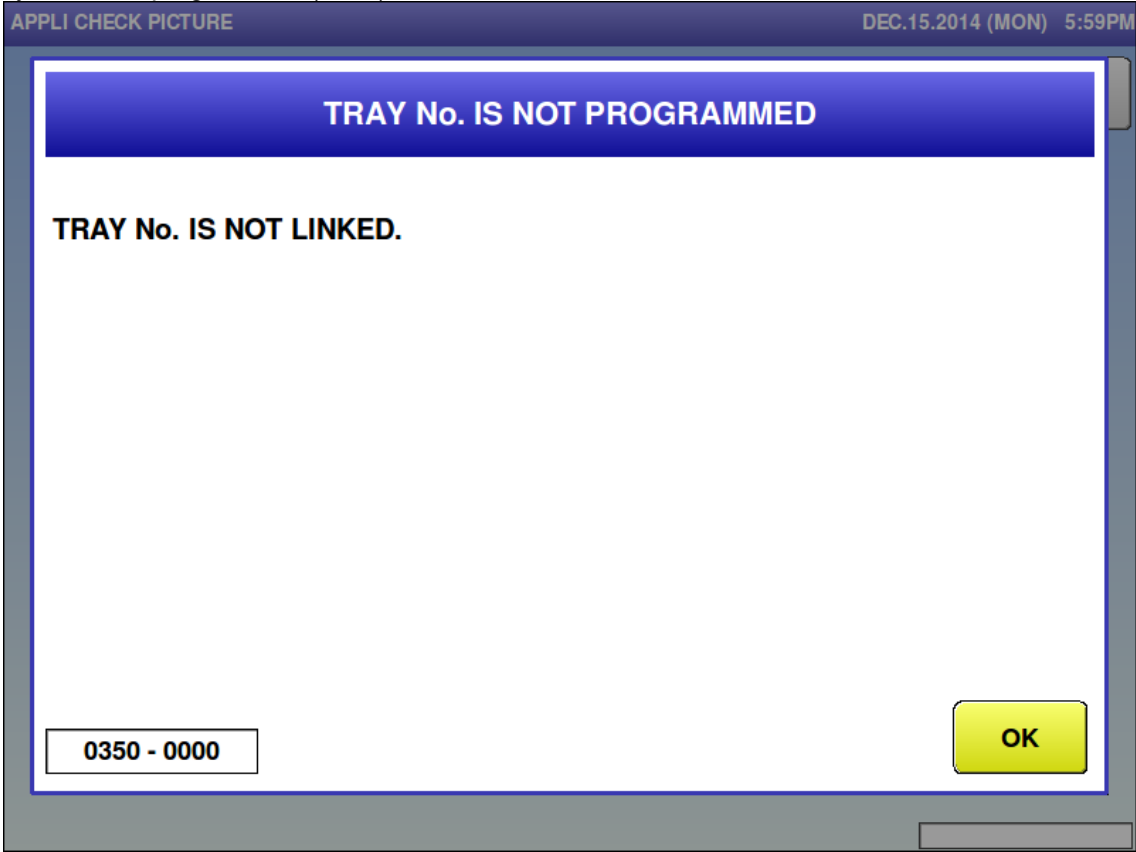

Error content	Tray no. is not programmed in product.
Detail	
Solution	[OK] button
Action by user	Enter the tray number to use.
Action by service representative	Confirm the product master. Confirm the tray master. Confirm the host product master when linked with the host system.
Related part	Main board
Remarks	

■ Label is remaining (0351)

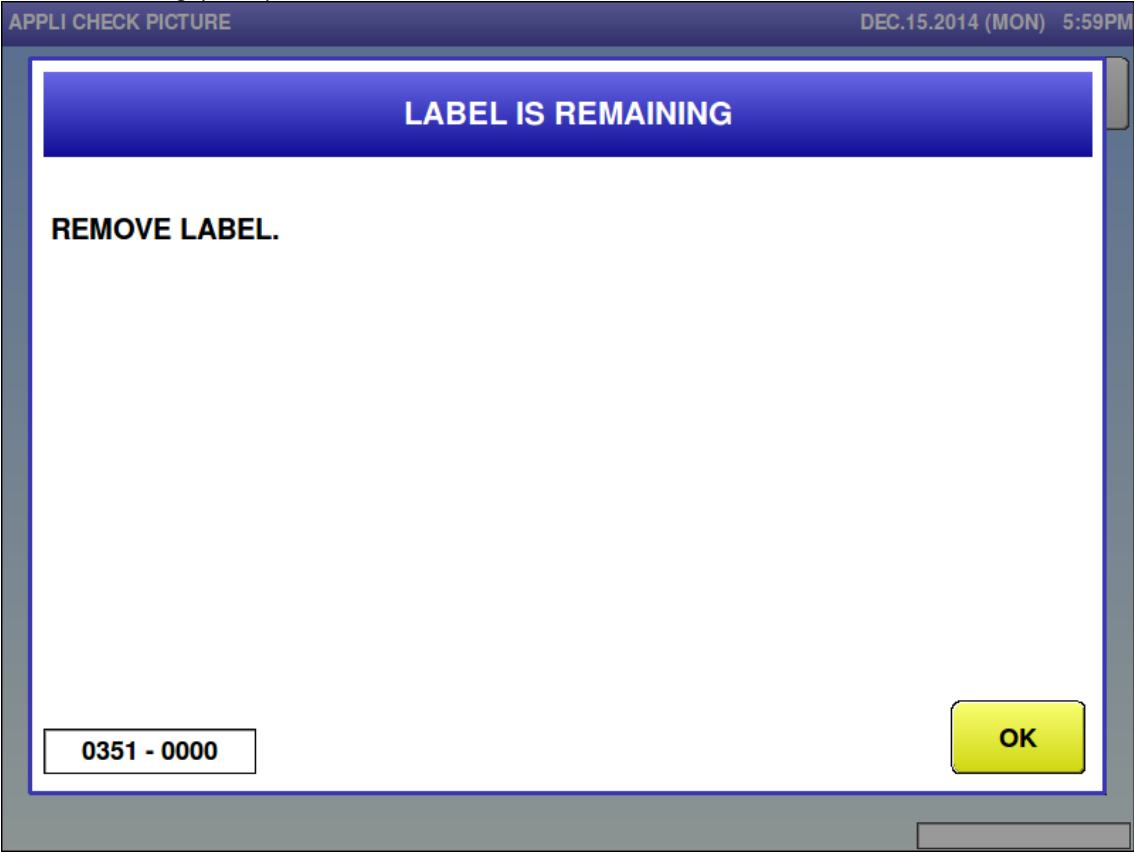

Error content	Label is remaining.
Detail	
Solution	Remove label, [OK] button.
Action by user	Press the [OK] button to finish production.
Action by service representative	Press the [OK] button to finish production. Confirm that there is no actual result remaining error.
Related part	Main board
Remarks	

■ Tray no. is not programmed (0355)

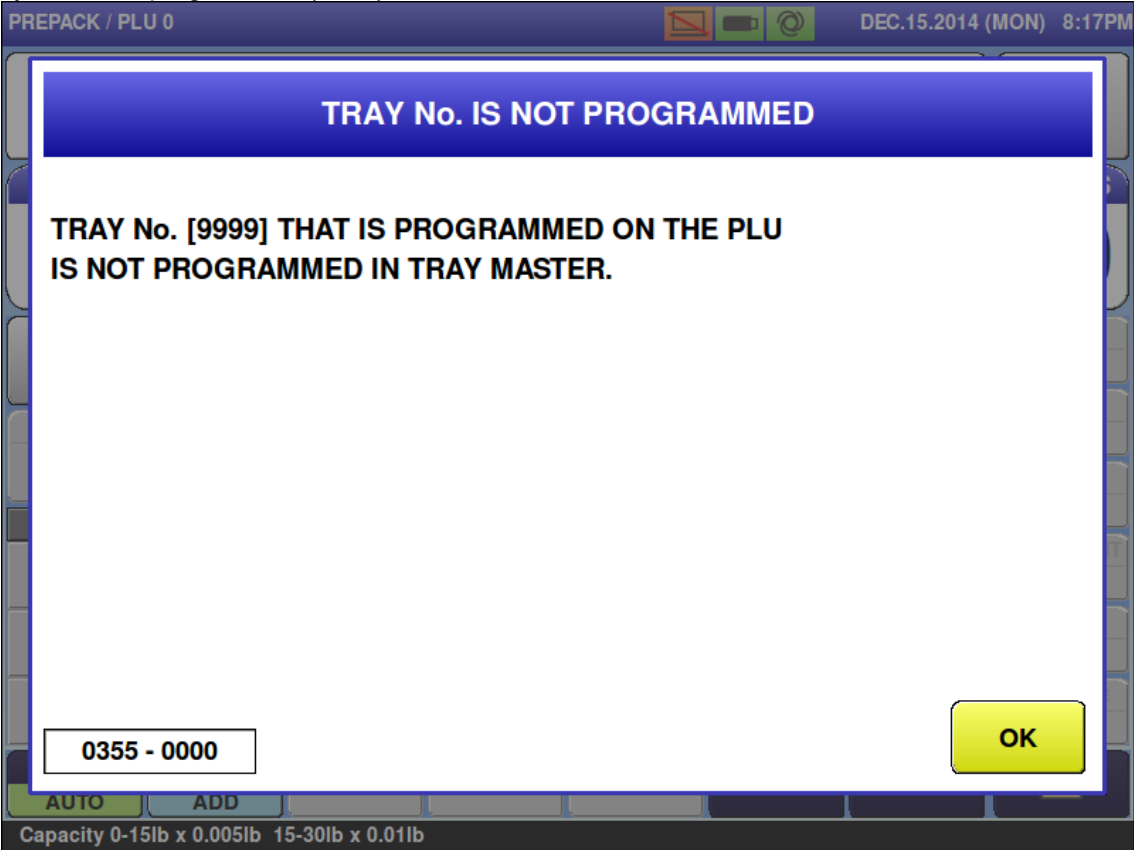

Error content	The tray number set for the product is not registered in the tray master.
Detail	
Solution	[OK] button
Action by user	Register the tray number to be used for tray master. Confirm the product master.
Action by service representative	Confirm the tray master and product master. Confirm the host product master and tray master when linked with the host system.
Related part	Main board
Remarks	Tray no. that is set is displayed.

■ Open the front cover (0360)

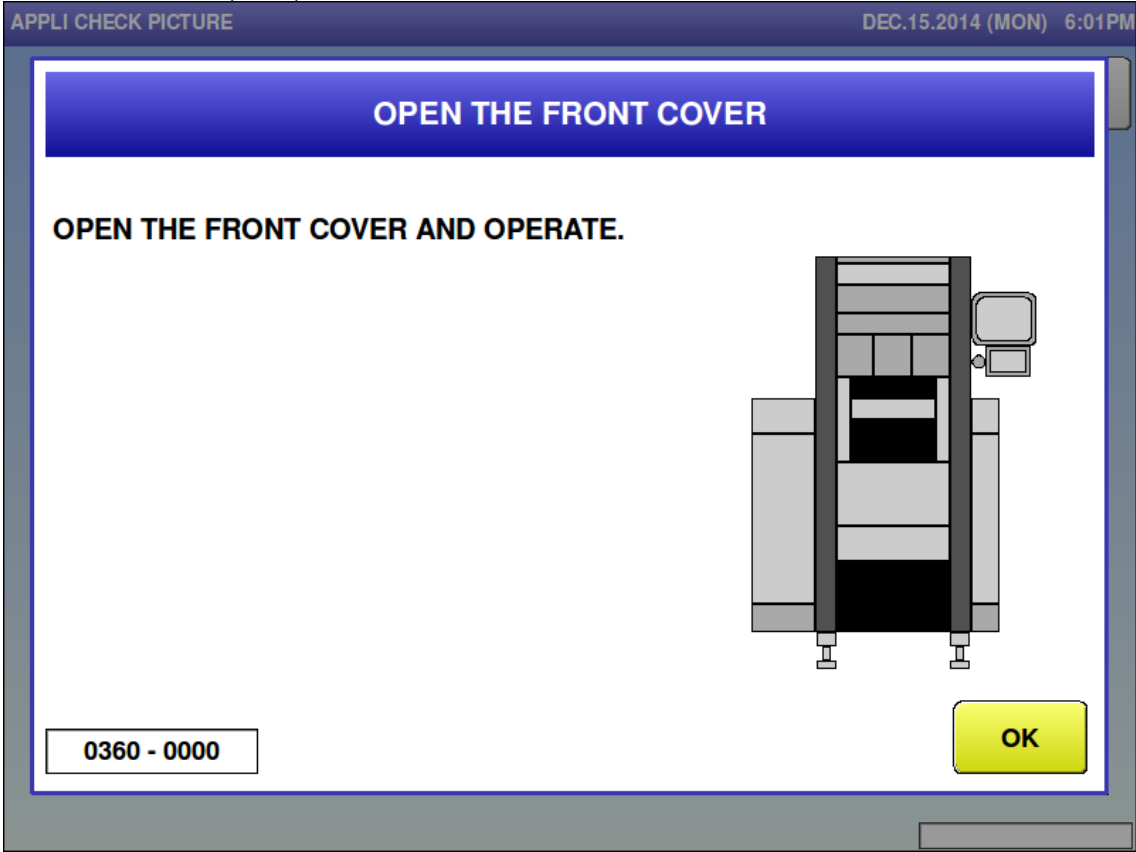

Error content	Front cover is closed.
Detail	Occurs when performing printing or unloaded feed (No.1.and 2) while front cover is closed.
Solution	Open the front cover, [OK] button.
Action by user	Open the front cover.
Action by service representative	Open the front cover.
Related part	Main board, wrapping machine board
Remarks	

■ It could not detect the tray (0363)

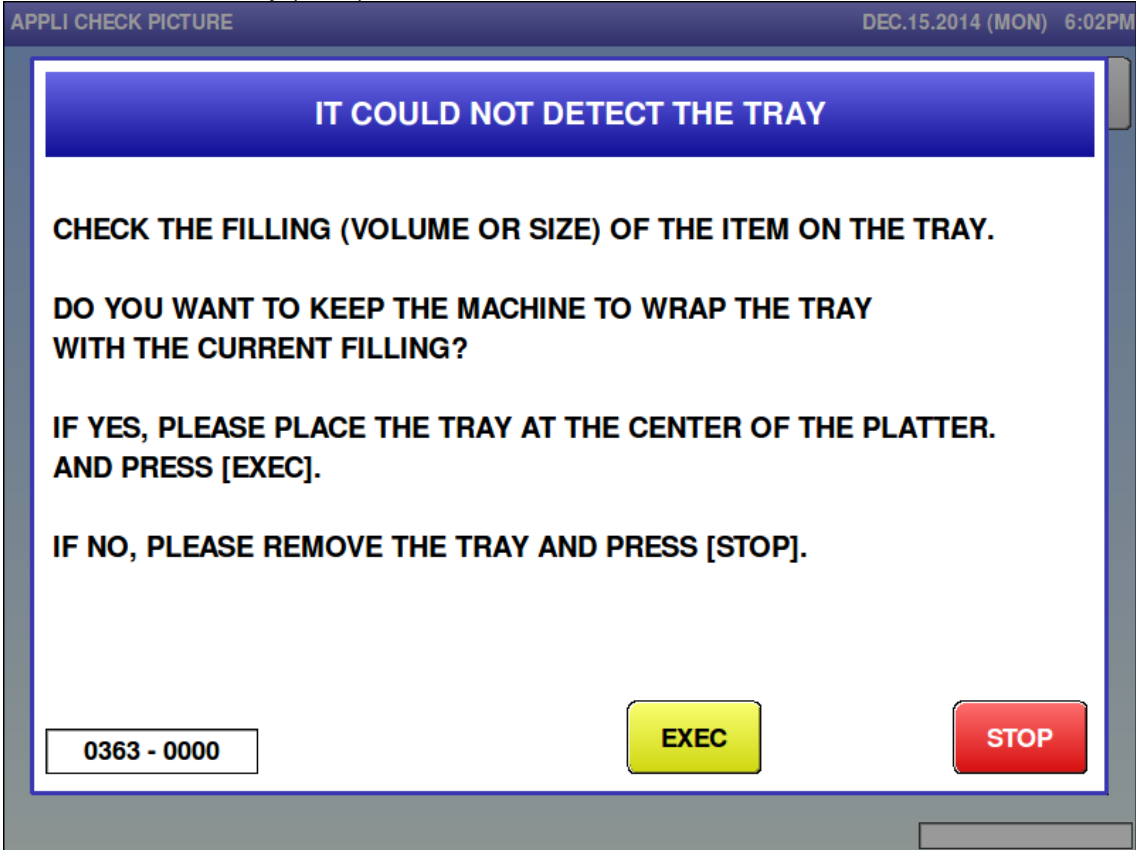

Error content	It could not detect the tray.
Detail	Occurs when a centered tray can't be detected normally. Occurs when a transparent tray is set to the above conditions.
Solution	Unstable, [EXEC] button.
Action by user	Place the tray again. Confirm the tray master. Press the [EXEC] button. Change the setting to [Centering: No].
Action by service representative	Confirm the tray master. Change the setting to [Centering: No].
Related part	Main board, detection board
Remarks	

■ Product is remaining (0368)

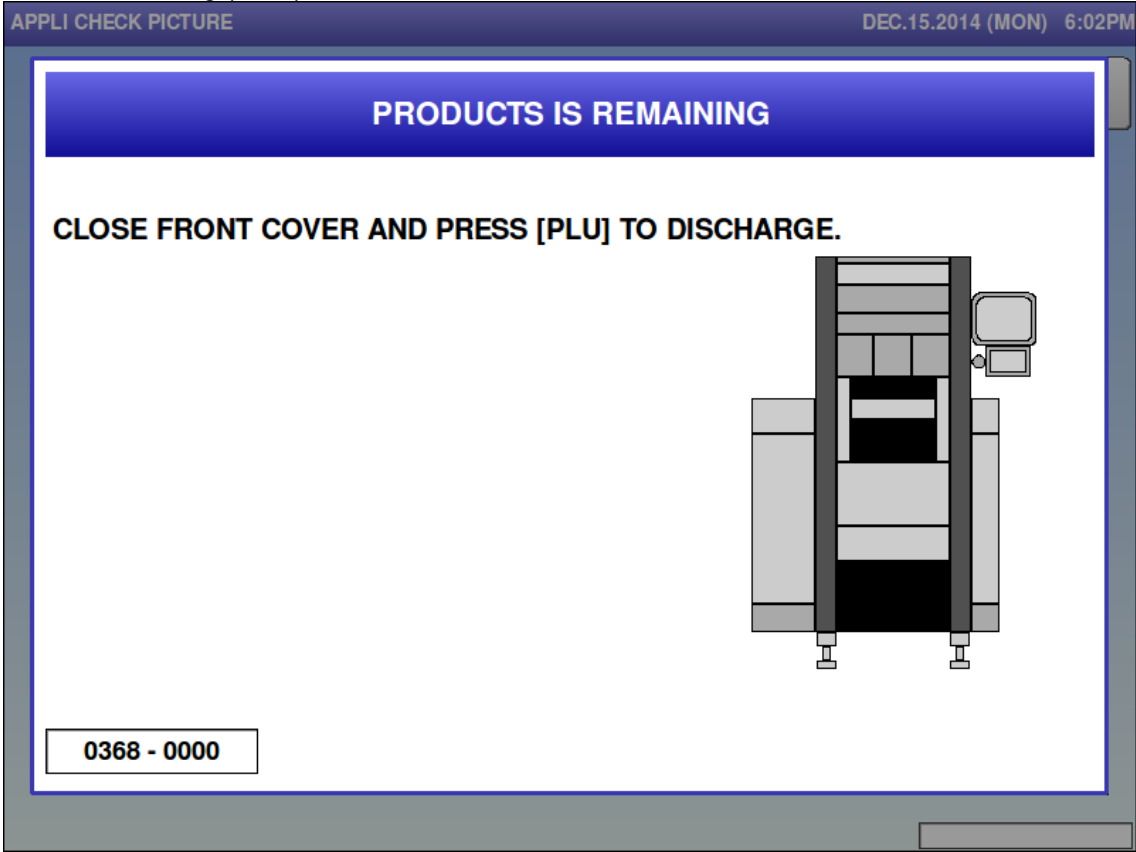

Error content	The front cover was opened when the wrapper stopped and products remained on the lift.
Detail	
Solution	[PLU] button
Action by user	Close the front cover and press the [PLU] key.
Action by service representative	Close the front cover and press the [PLU] key.
Related part	Main board, wrapping machine board
Remarks	* Product is discharged by pressing the [PLU] button. * Added to the total amount.

■ No USB memory (0396)

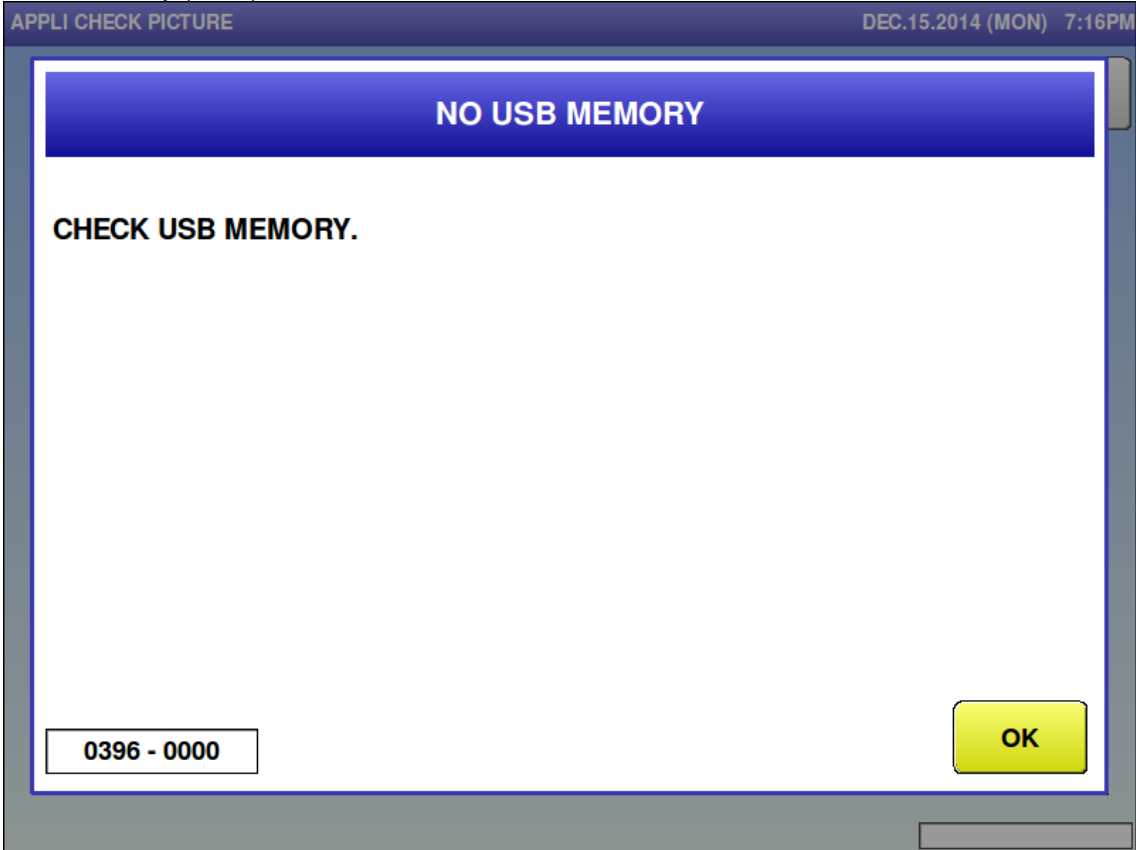

Error content	USB memory is not inserted.
Detail	
Solution	[OK] button
Action by user	Set the USB memory to the machine.
Action by service representative	Set the USB memory to the machine. Confirm the USB memory (recommended by Ishida) inserted.
Related part	Main board
Remarks	

6.3.4 Wrapper-related Error (No. 400s, 500s)

- Wrapper is not connected (401)

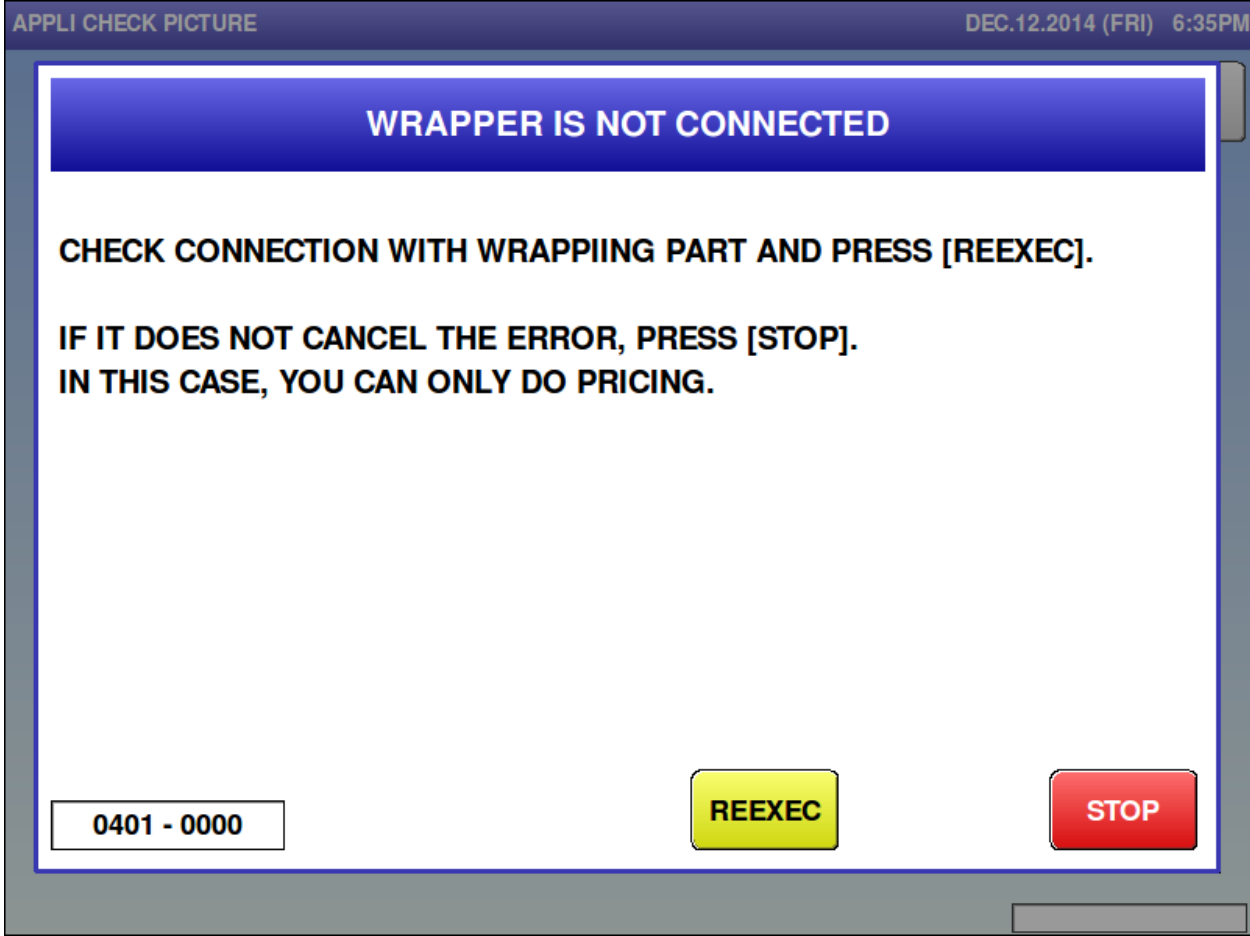

Error content	Wrapper is not connected.
Detail	Communication error before power has been turned ON. Communication phase No. is listed in the sub-error.
Solution	[STOP] button=> Cancel error [REEXEC] button => Re-check the connection with the wrapper.
Action by user	Perform turn ON/OFF of the power supply.
Action by service representative	
Related part	
Remarks	After pressing the [STOP] button, only pricing can be performed.

■ No response from wrapper (402)

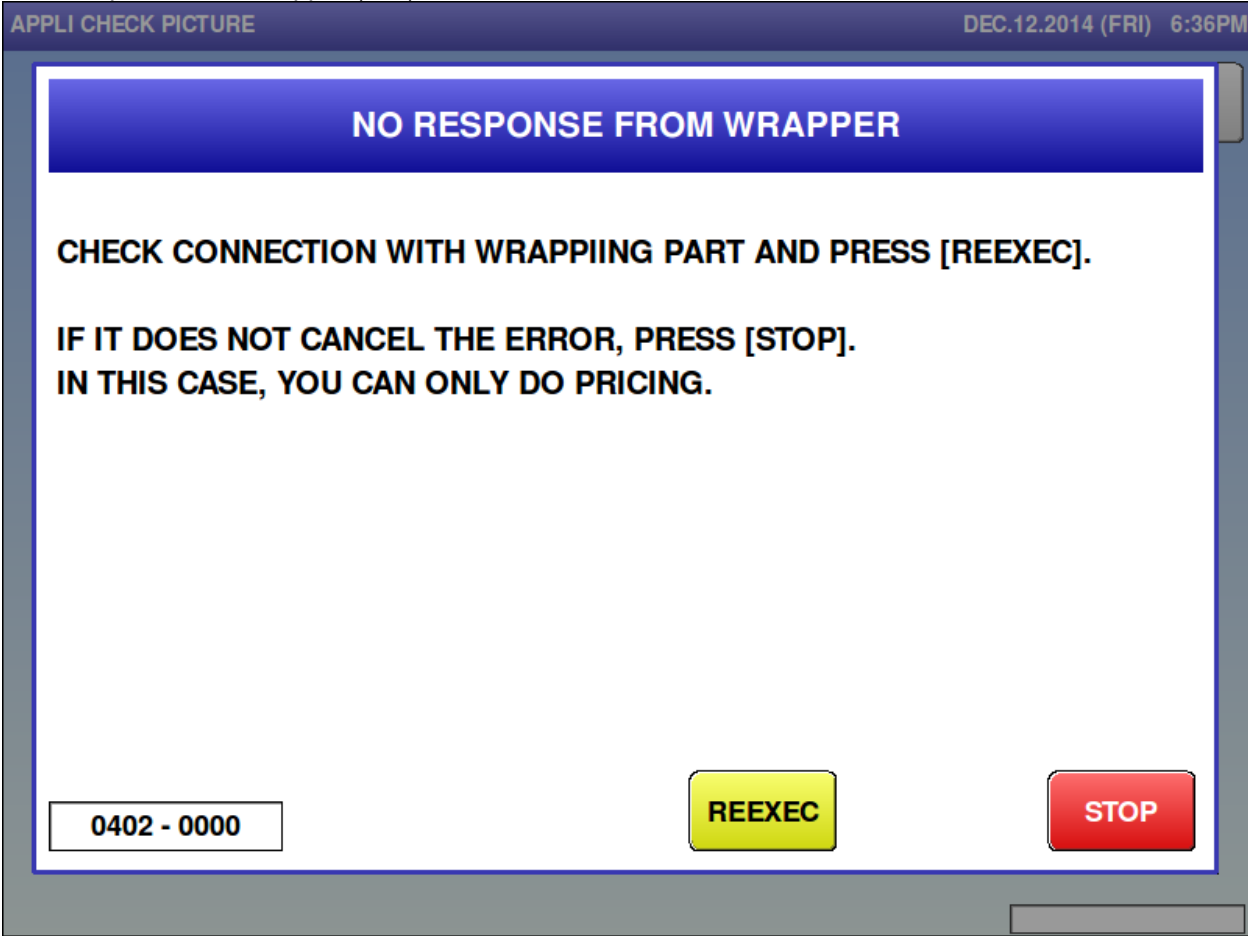

Error content	No response from wrapper.
Detail	Communication error after power has been turned ON. Communication phase is listed in the sub-error.
Solution	[STOP] button => Cancel error. [REEXEC] button => Re-check the connection with the wrapper.
Action by user	Perform a power cycle.
Action by service representative	
Related part	① P-1105 [A200] ② 24VDC to the power supply (XJ12) of P-1105 [A200] ③ RS485 communication cable between main boards (P-1100, P-1163, P-1000) [A10] and P-1105 [A100, A200, A300]
Remarks	After pressing the [STOP] button, only pricing can be performed.

■ Problem caused on wrapper (403)

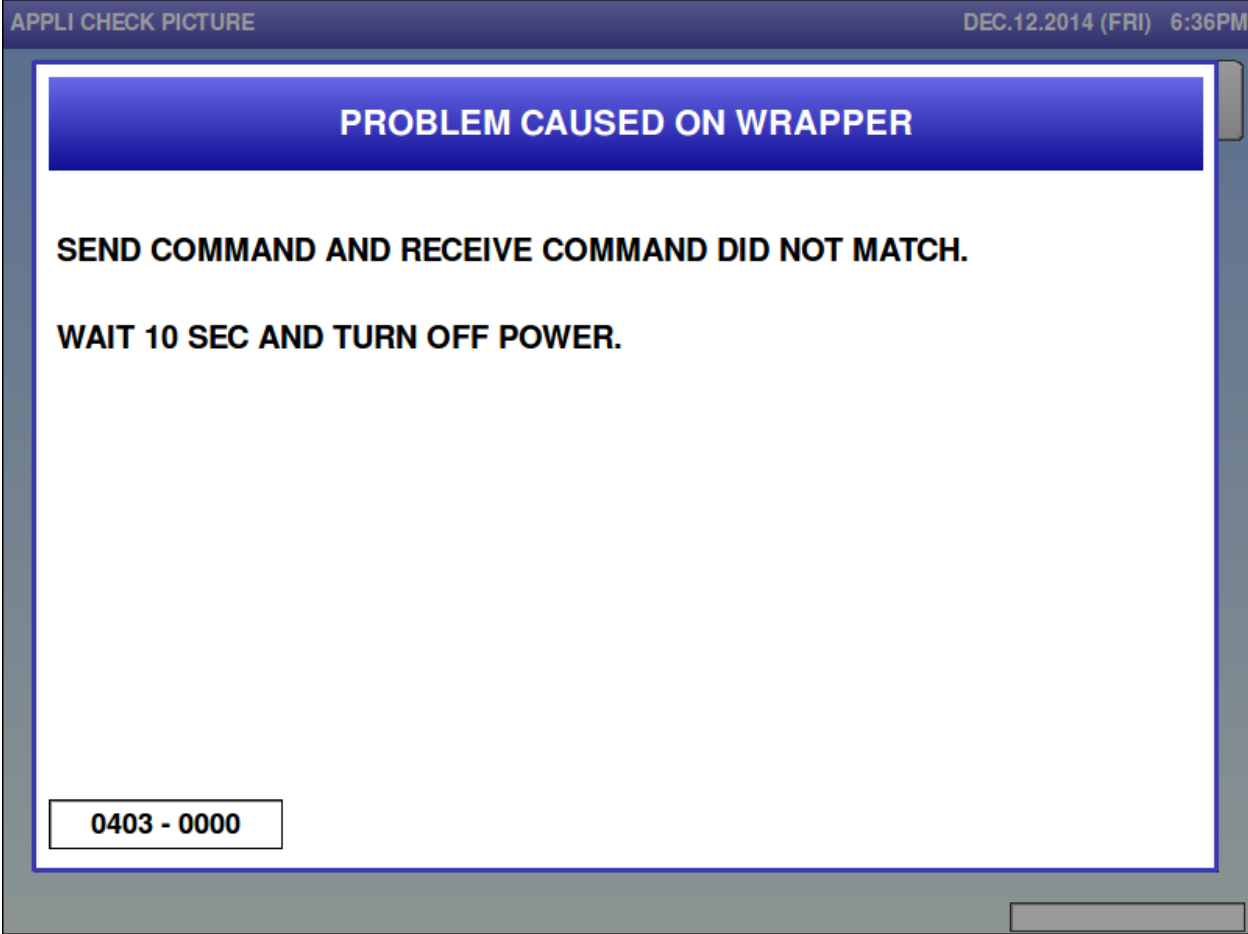

Error content	Communication failure with the wrapper.
Detail	Send command and receive command do not match.
Solution	Restore power.
Action by user	Perform a power cycle.
Action by service representative	
Related part	① Main board (P-1100, P-1163 or P-1000) [A10] ② P-1105 [A100, A200, A300]
Remarks	

■ Wrapper detected temporary blackout (406)

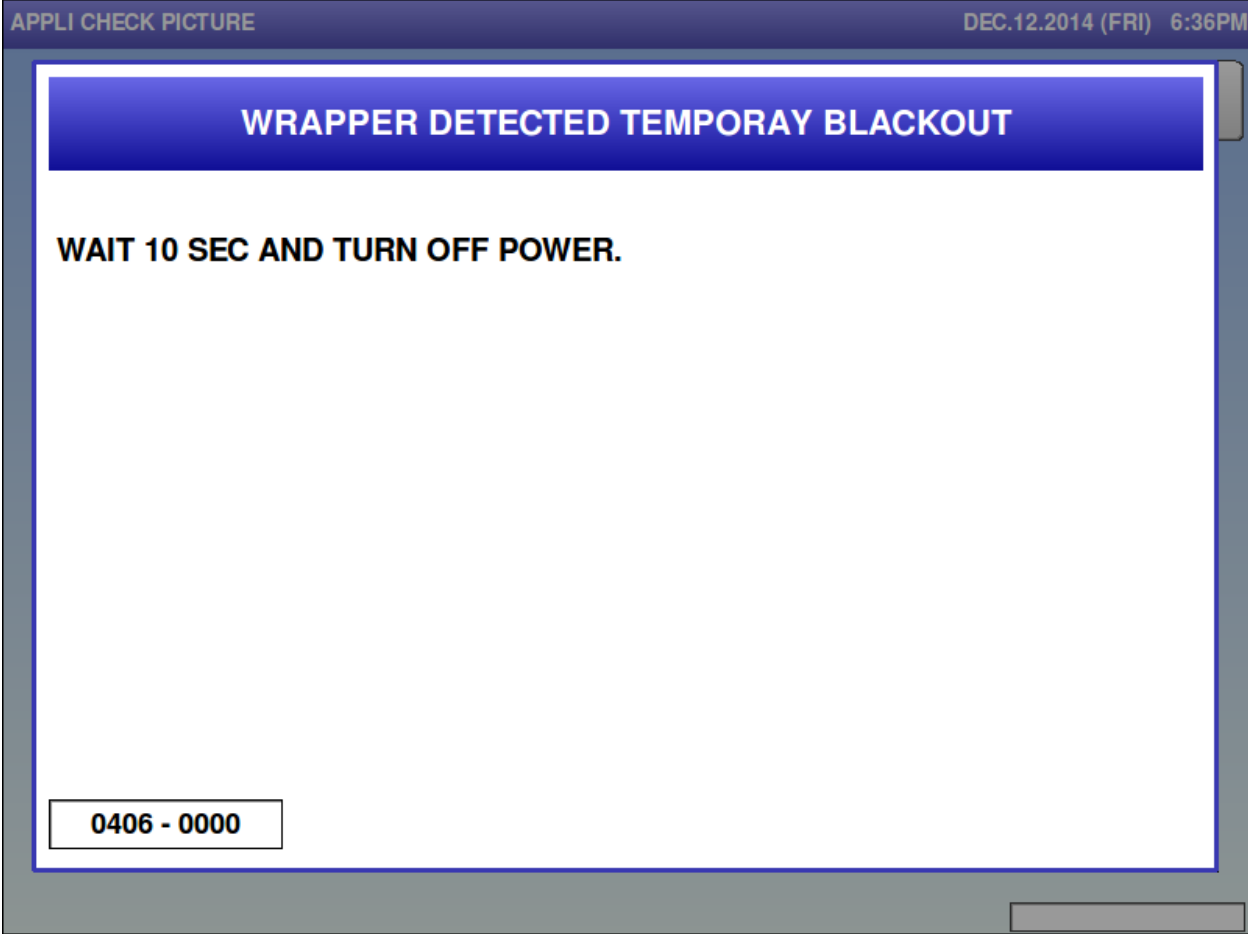

Error content	The wrapper control board detected the CPU reset.
Detail	The console received power ON notification (status query) twice from the wrapper.
Solution	Restore power
Action by user	Perform a power cycle.
Action by service representative	
Related part	① P-1105 [A200] ② Control unit section switching power supply [U10]
Remarks	

■ Temporary blackout on console (407)

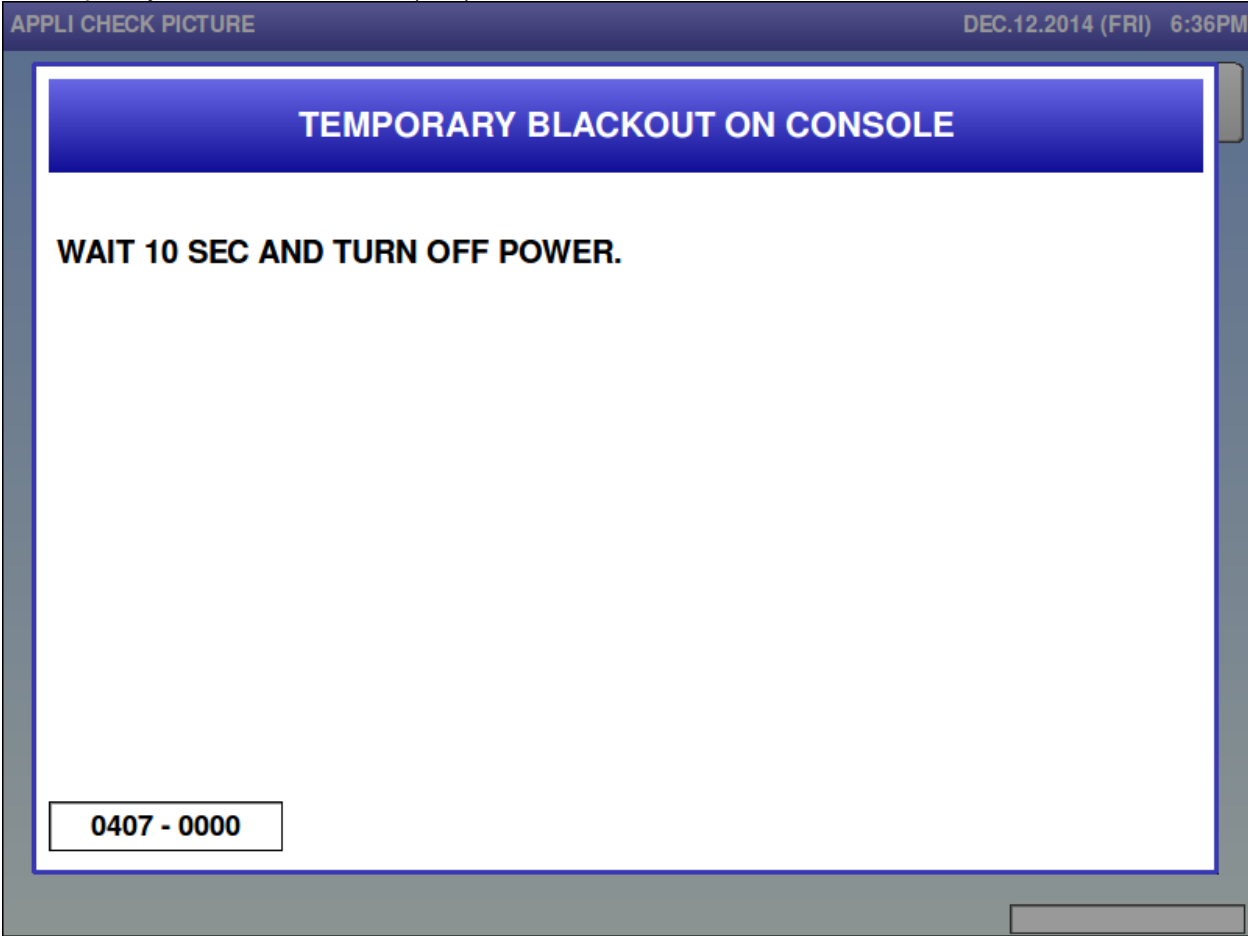

Error content	Console CPU was reset.
Detail	Received Power ON notification from the console twice.
Solution	
Action by user	Perform a power cycle.
Action by service representative	
Related part	① Main board (P-100, P-1163 or P-1000) [A10] ② Control unit section switching power supply [U10]
Remarks	

■ No response from wrapper (409)

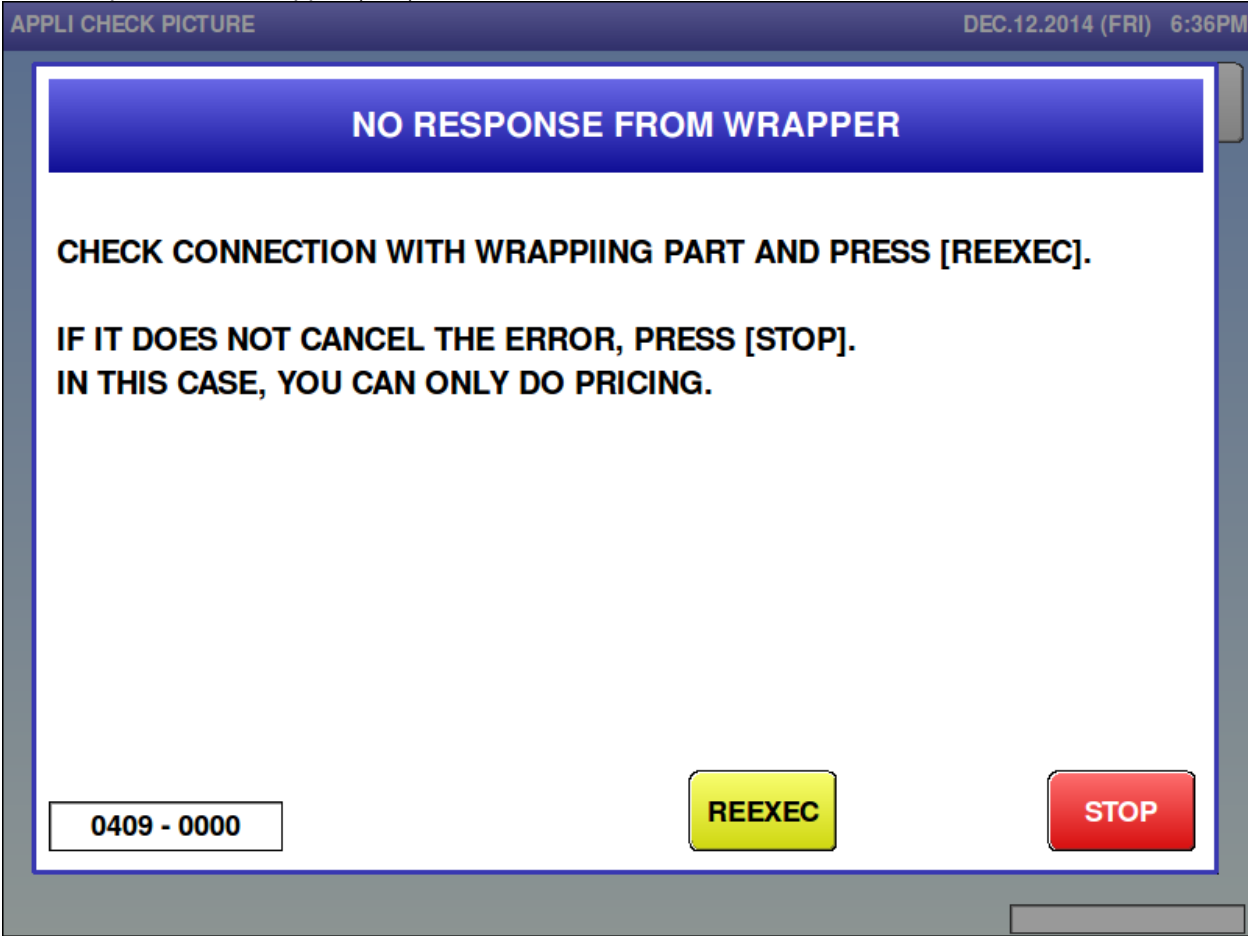

Error content	The wrapper is not connected.
Detail	Communication error when power has been turned ON. Communication phase is listed in the sub-error.
Solution	[STOP] button => Cancel error. [REEXEC] button => Re-check the connection with the wrapper.
Action by user	Perform a power cycle.
Action by service representative	
Related part	
Remarks	After pressing the [STOP] button, only pricing can be performed.

■ Lift motor is abnormal (410)

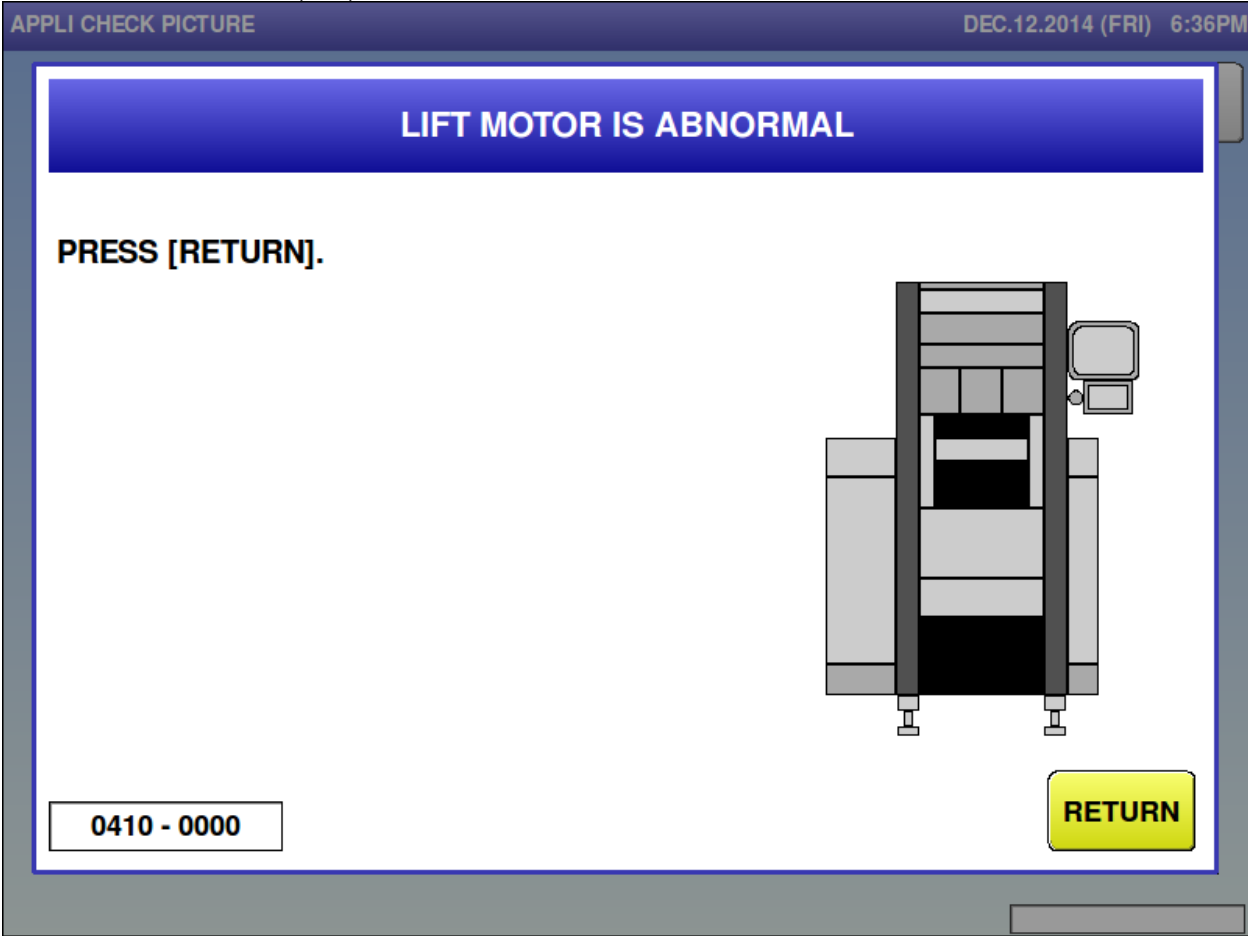

Error content	Lift motor is abnormal
Detail	<p>Lift motor operation did not finish normally. Sub-error meanings are as follows:</p> <p>0001: Operation wasn't completed when the operation protection timer run out. 0003: DCB motor is overloaded. 0004: Feedback pulse from DCB motor has an error (phase interruption). 0101: The lower side of lift [B203] is not receiving light, when lowering the lift. 0102: The lower side of lift [B203] is emitted light, after switching or returning the lift. 0103: The origin point of lift [B202] and the lift safety [B204] are not receiving light when the lift backs to its origin point. 0104: The origin point of lift [B202] and the lift safety [B204] are not receiving light when the lift is in its switch position. 0105: The origin point of lift [B202] is not receiving light when lowering the lift. The lift lower side position [B203] is emitted light wen the lift backs to its origin point. 0106: Do not block light of the lift origin point [B200] when the lift is moving to the origin point after the lift changeover. 0107: The lift origin point [B200] is not receiving light when lowering the lift. 0201: The lift origin point [B200] is not receiving light even after a certain period of time after the lift starts operation.</p>
Solution	[RETURN] button
Action by user	
Action by service	

representative	
Related part	① P-1105 [A200] ② Motor for lift [M06] ③ Sensors described above: [B200], [B202], [B203], [B204]
Remarks	

■ Motor for film feed is abnormal (411)

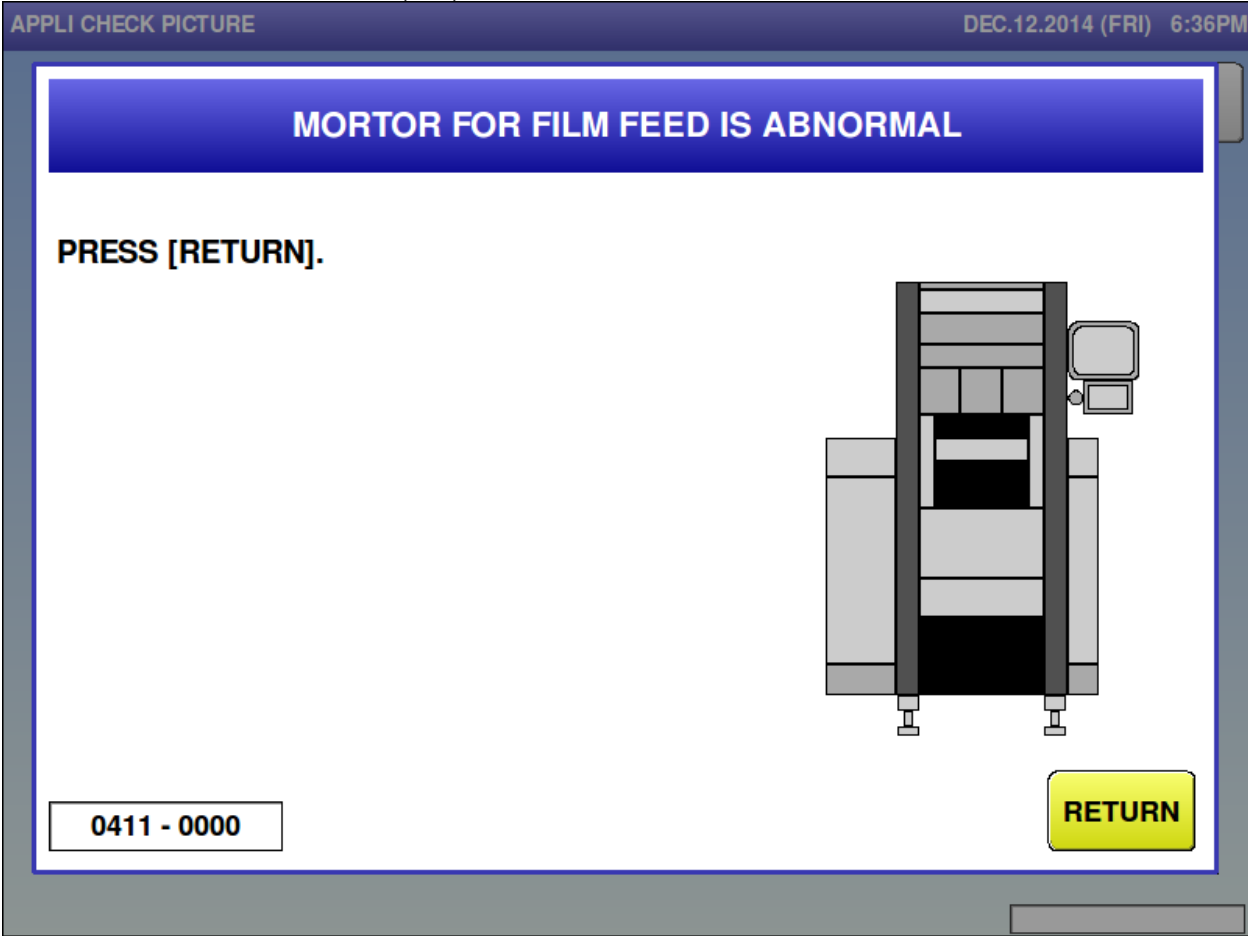

Error content	Motor for film feed is abnormal.
Detail	Film insert motor operation did not finish normally. Sub-error meanings are as follows: 0001: Operation wasn't completed when the operation protection timer run out. 0011: The insert motor was stepped out when the film is traveling. 0021: The insert didn't back to the normal position when the cutter starts operation.
Solution	[RETURN] button
Action by user	
Action by service representative	
Related part	① P-1105 [A300] ② P-1006 [A301] ③ Stepping motor for film feed [M303] ④ Film feed origin point [B301]
Remarks	

■ Motor for film change is abnormal (412)

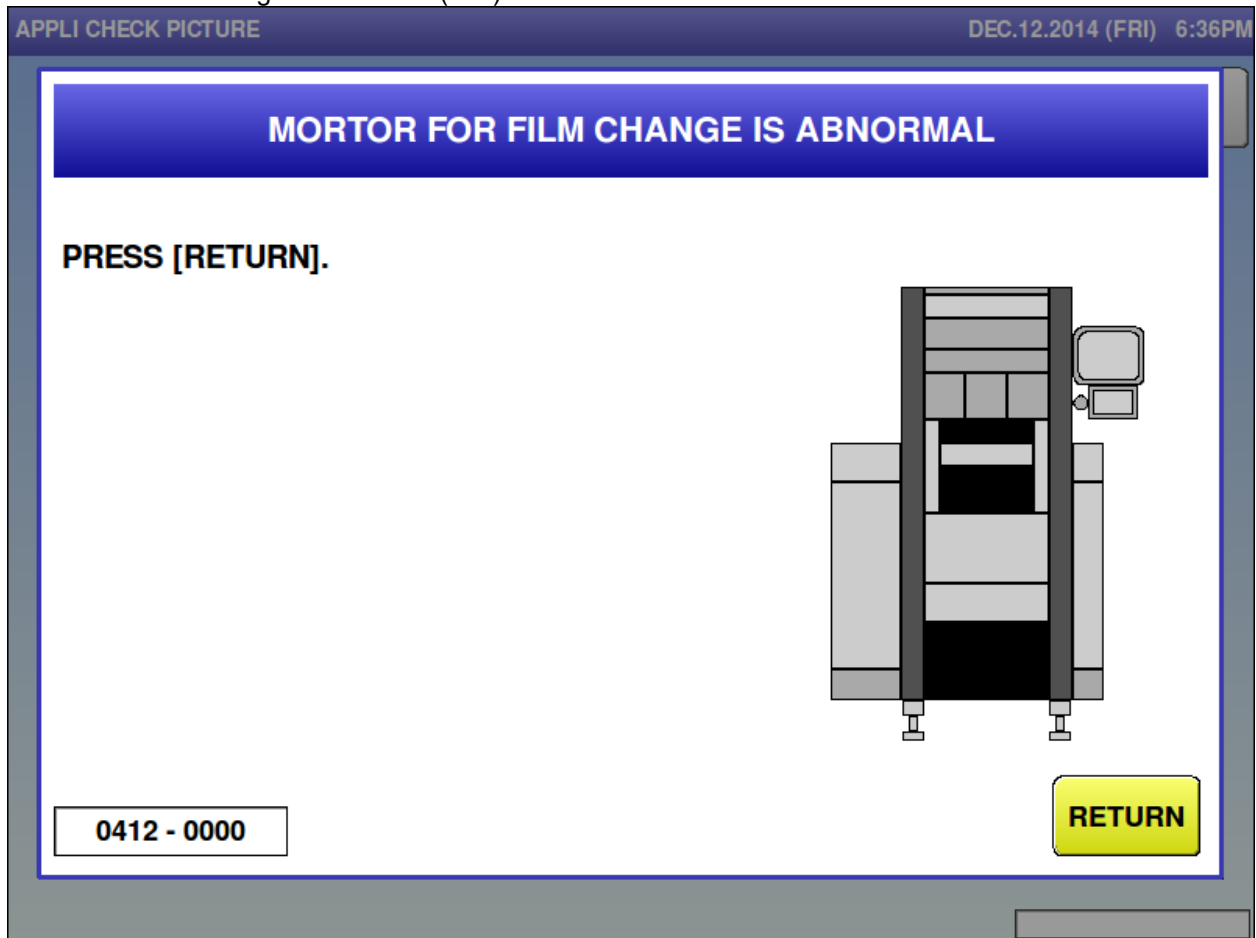

Error content	Motor for film change error.
Detail	<p>Motor for film change operation did not finish normally.</p> <p>Sub-error meanings are as follows:</p> <p>0001: Operation wasn't completed when the operation protection timer run out.</p> <p>0011, 12: The origin point of film 2 change [B309] is not receiving light at the timing not to receive light.</p> <p>0020: The origin point of film 1 change [B304] and the origin point of film 2 change [B309] are receiving light when the insert operation or change operation start.</p>
Solution	[RETURN] button
Action by user	
Action by service representative	
Related part	<p>① P-1105 [A300]</p> <p>② P-1006 [A301]</p> <p>③ Stepping motor for film change [M304]</p> <p>④ Origin point of film 1 change [B304], origin point of film 2 change [B309]</p>
Remarks	

■ Film driving motor is abnormal (413)

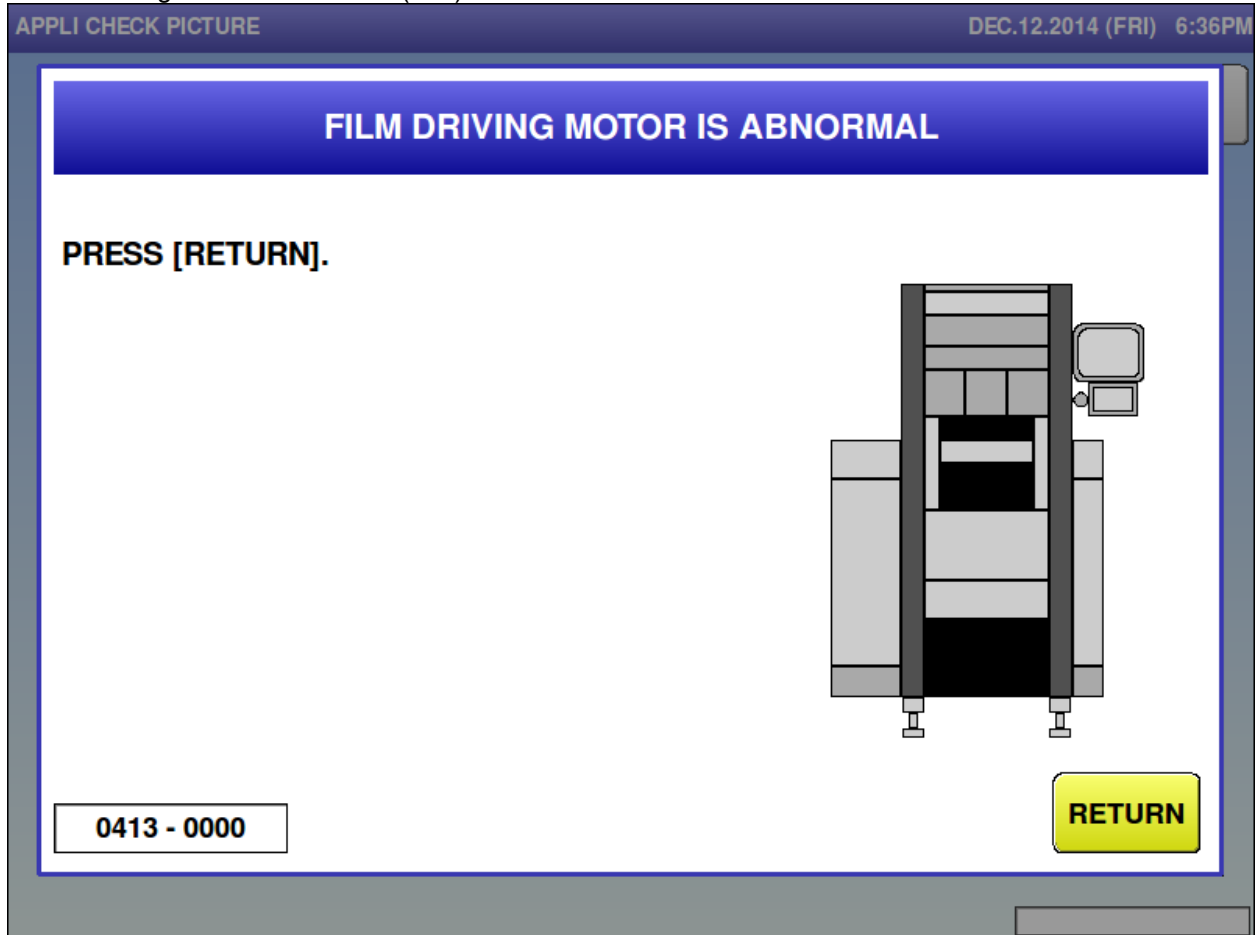

Error content	Film driving motor error.
Detail	Film driving (right) motor operation did not finish normally. Sub-error meanings are as follows: 0001: Operation wasn't completed when the operation protection timer run out. 0003: DCB motor is overloaded. 0004: Feedback pulse from DCB motor has an error (phase interruption).
Solution	[RETURN] button
Action by user	
Action by service representative	
Related part	① P-1105 [A300] ② Film driving motor [M08]
Remarks	

■ Motor for back squeeze plate is abnormal (415)

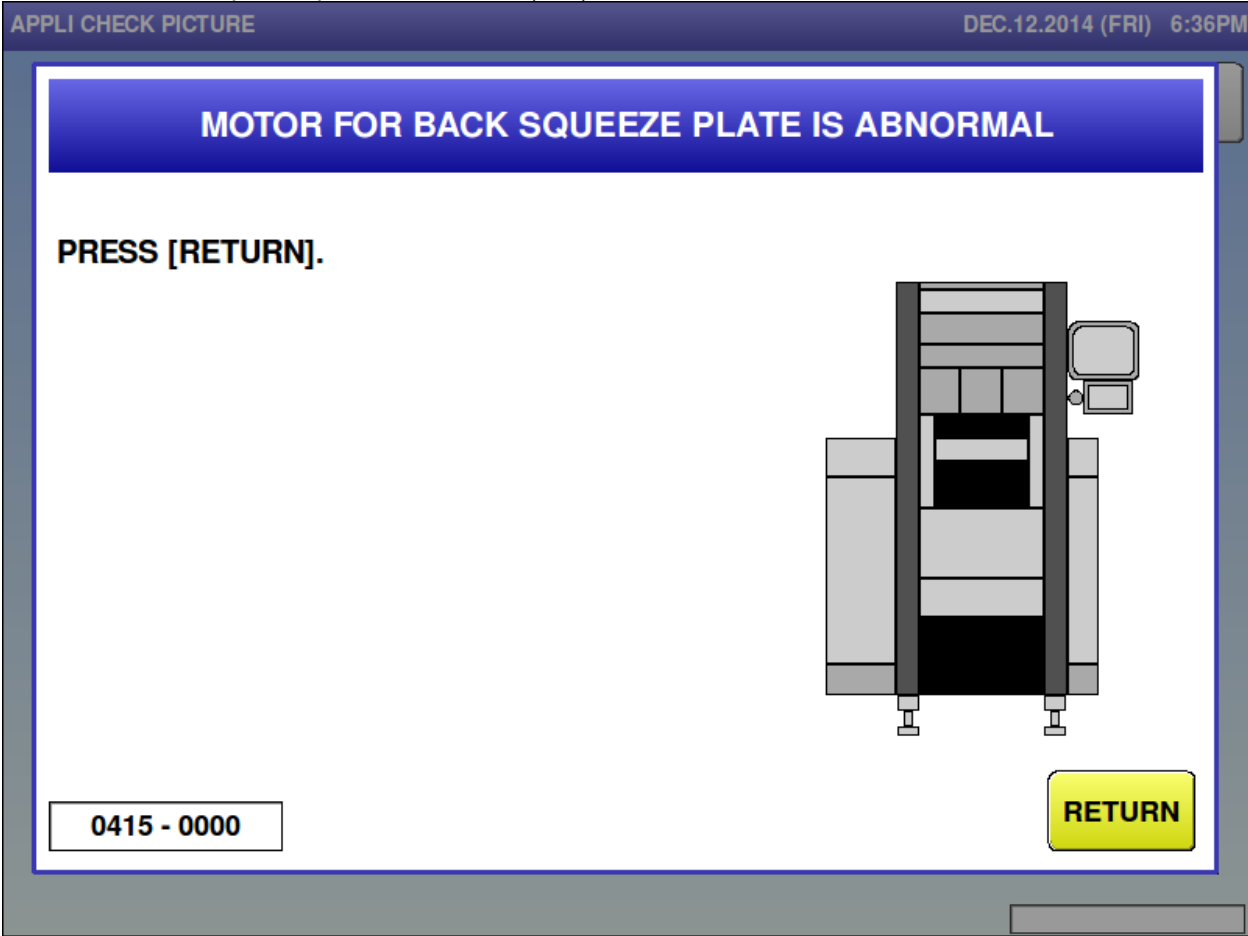

Error content	Motor for back squeeze plate error.
Detail	<p>Motor for back squeeze plate operation did not finish normally.</p> <p>Sub-error meanings are as follows:</p> <p>0001: Operation wasn't completed when the operation protection timer run out.</p> <p>0003: DCB motor is overloaded.</p> <p>0004: Feedback pulse from DCB motor has an error (phase interruption).</p> <p>0011: The origin sensor is not receiving light at the timing with the origin sensor not receiving light.</p>
Solution	[RETURN] button
Action by user	
Action by service representative	
Related part	<p>① P-1105 [A100]</p> <p>② Driving motor for back squeeze plate [M02]</p> <p>③ Origin point of back squeeze plate [B101]</p>
Remarks	

■ Motor for R/L squeeze is abnormal (416)

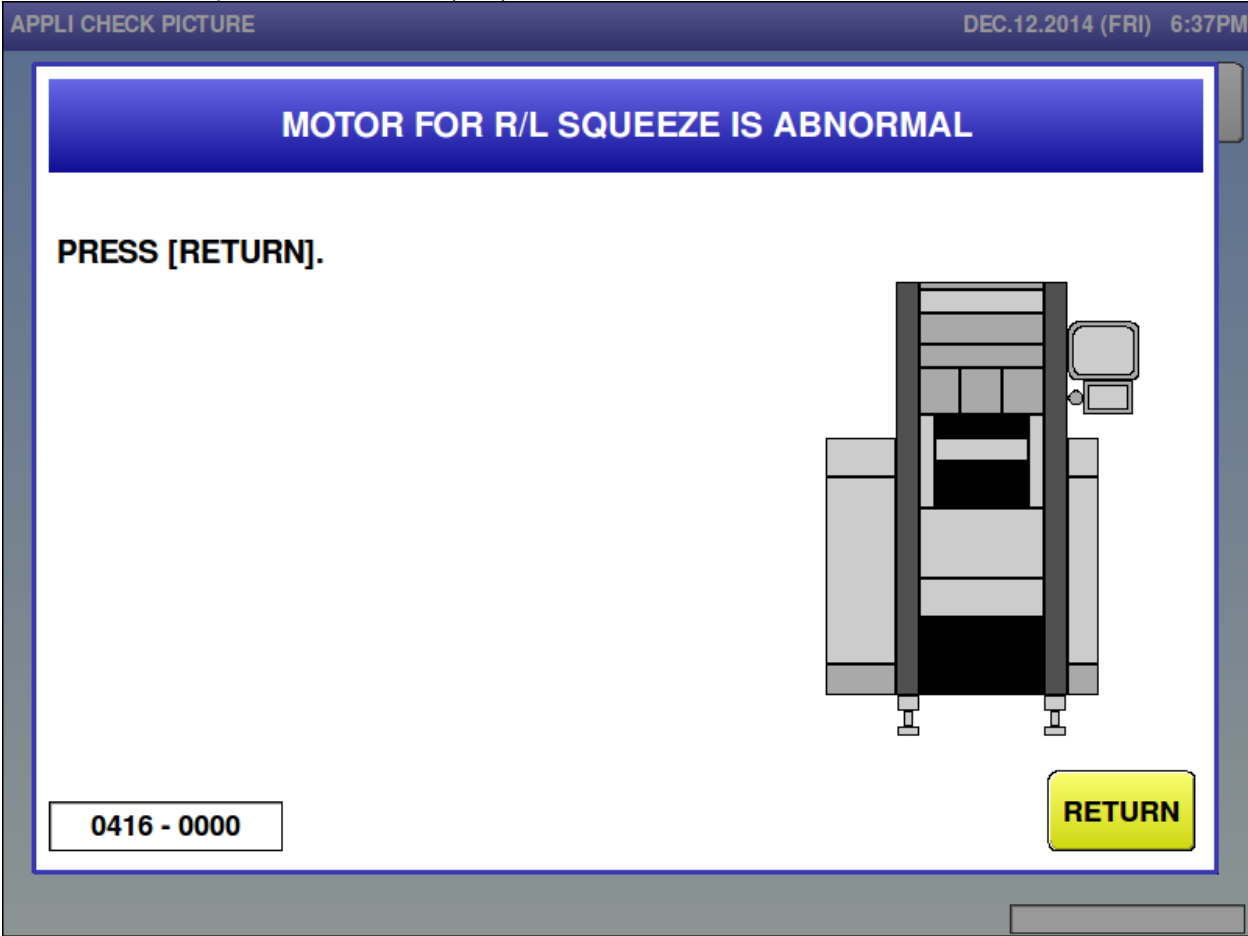

Error content	Motor for R/L squeeze error.
Detail	<p>Motor for R/L squeeze operation did not finish normally.</p> <p>Sub-error meanings are as follows:</p> <p>0001: Operation wasn't completed when the operation protection timer run out.</p> <p>0003: DCB motor is overloaded.</p> <p>0004: Feedback pulse from DCB motor has an error (phase interruption).</p> <p>0011: The origin sensor is not receiving light at the timing with the origin sensor not receiving light.</p>
Solution	[RETURN] button
Action by user	
Action by service representative	
Related part	<p>① P-1105 [A100]</p> <p>② Driving motor for R/L squeeze [M03]</p> <p>③ Origin point of R/L squeeze [B102]</p>
Remarks	

■ Outfeed pusher motor is abnormal (417)

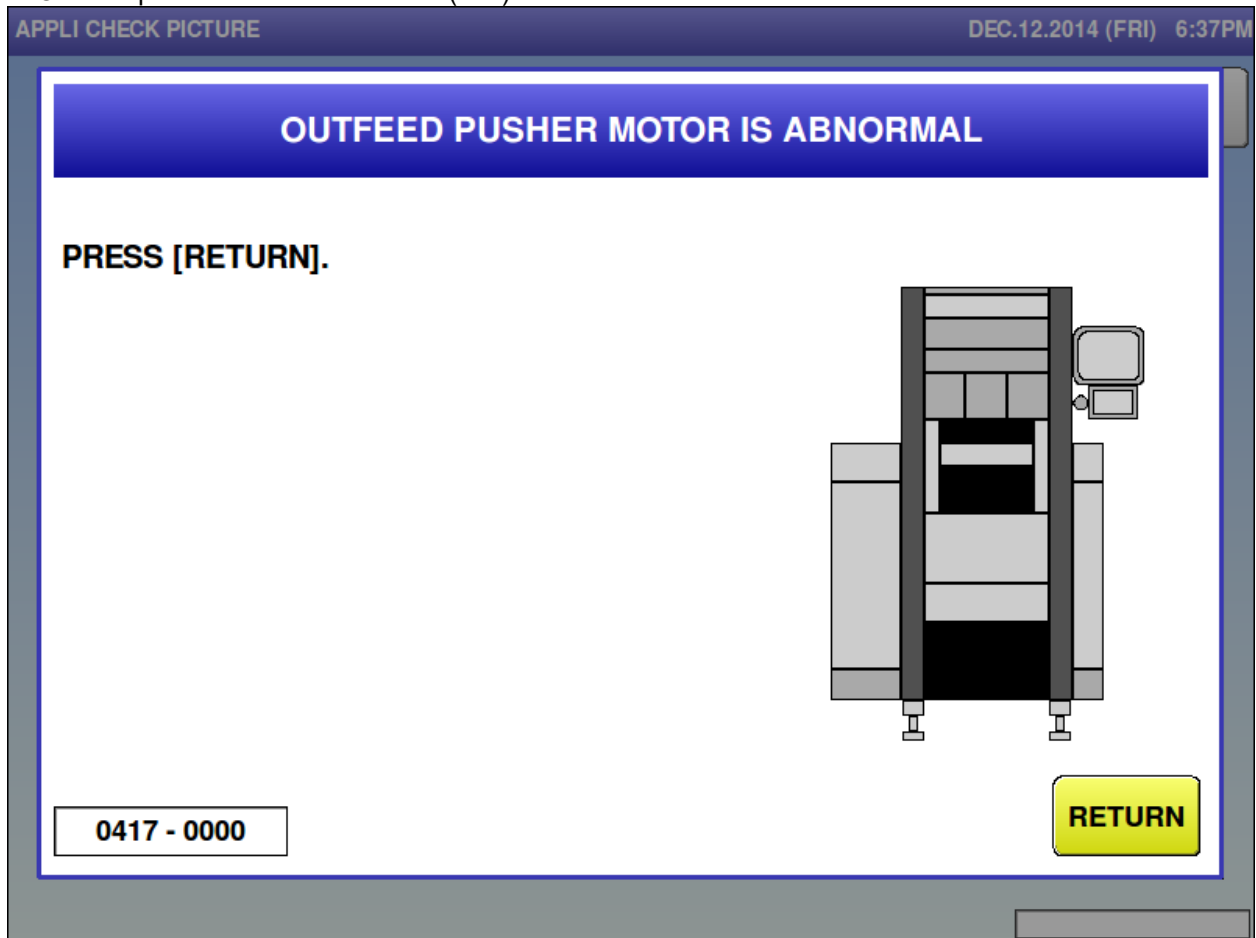

Error content	Outfeed pusher motor error.
Detail	<p>Outfeed pusher motor operation did not finish normally.</p> <p>Sub-error meanings are as follows:</p> <p>0001: Operation wasn't completed when the operation protection timer run out.</p> <p>0002: Cannot detect speed pulse signal from the DCB motor (driver board).</p> <p>0003: DCB motor is overloaded.</p> <p>0004: Feedback pulse from DCB motor has an error (phase interruption).</p> <p>0005: Began next product operation before the previous operation was completed (unsuitable wrapper condition).</p> <p>0006: The next product stuck out before the previous operation was completed (unsuitable wrapper condition).</p> <p>1003: Tray press operation wasn't completed when the operation protection timer run out.</p>
Solution	[RETURN] button
Action by user	
Action by service representative	
Related part	<p>① P-1105 [A100]</p> <p>② Driving motor for outfeed pusher [M01]</p>
Remarks	

■ Feeder motor is abnormal (418)

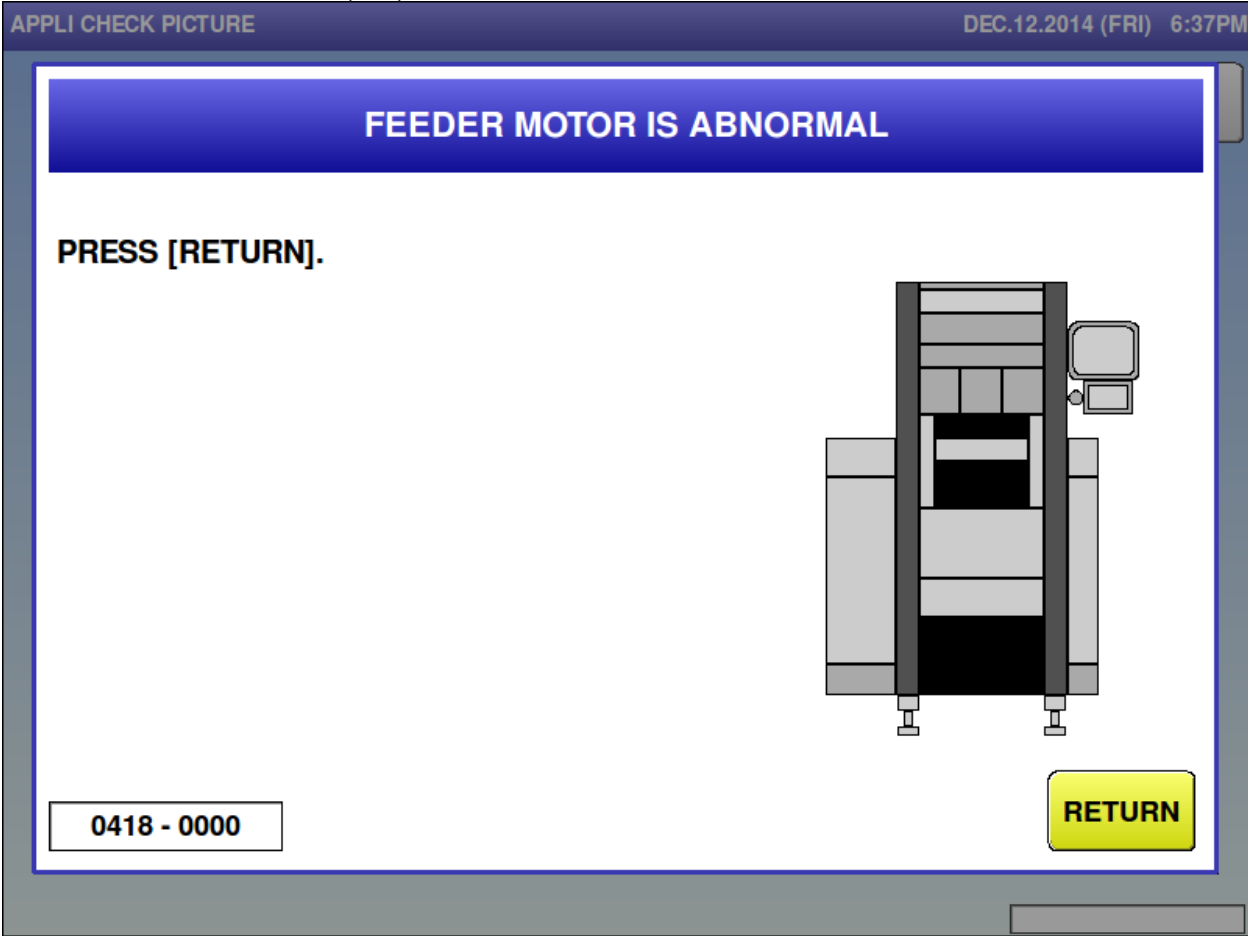

Error content	Feeder motor error.
Detail	Feeder motor operation did not finish normally. Sub-error meanings are as follows: 0001: Operation wasn't completed when the operation protection timer run out. 0003: DCB motor is overloaded. 0004: Feedback pulse from DCB motor has an error (phase interruption).
Solution	[RETURN] button
Action by user	
Action by service representative	
Related part	① P-1105 [A300] ② Driving motor for feeder [M09]
Remarks	0418-0003 - Check the condition of the drive belts on the large hex shaft on the right side of the wrapper. - Remove and inspect the film feeders for excessive film pieces or belt damage.

■ Motor front feeder move is abnormal (419)

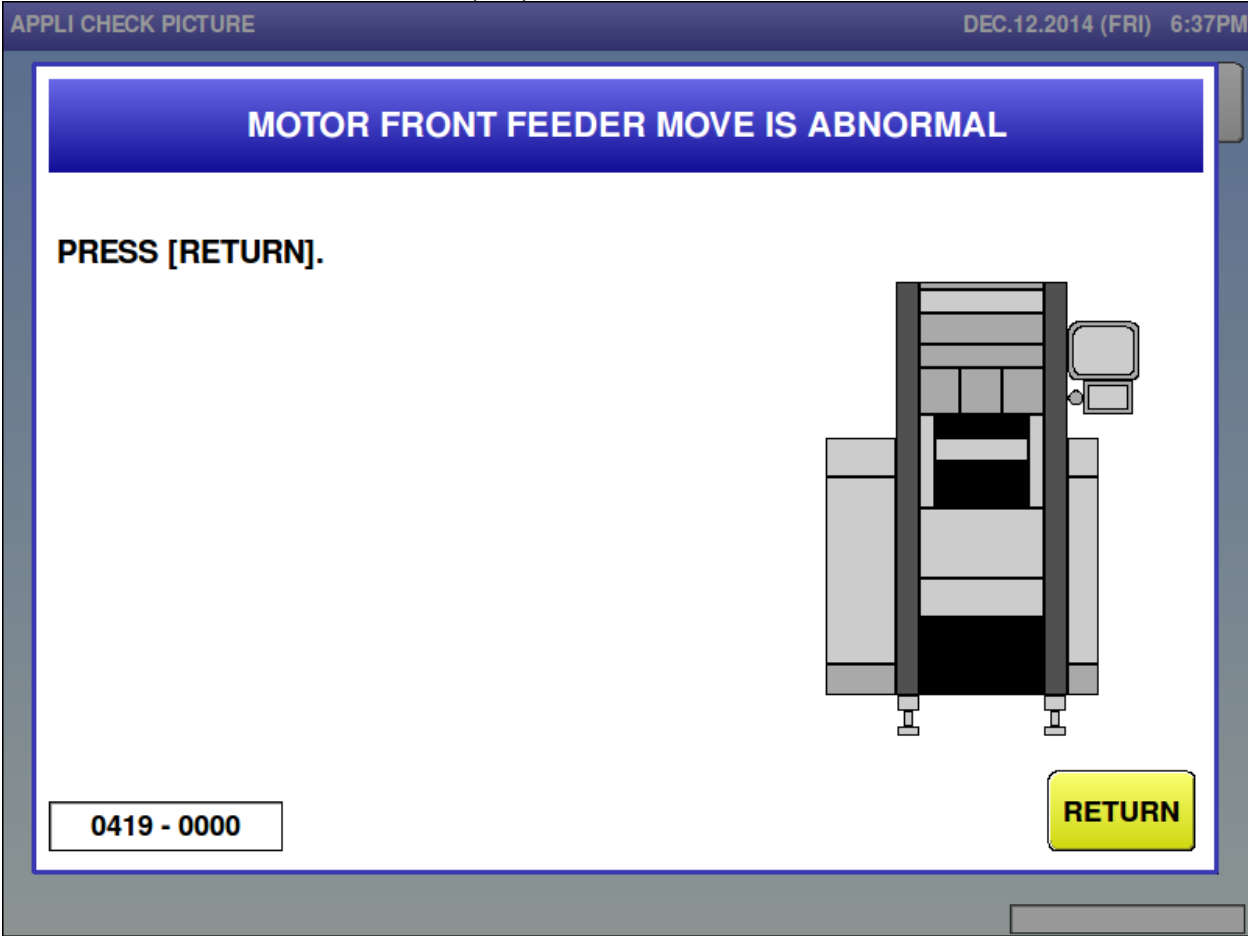

Error content	Motor front feeder error
Detail	Motor front feeder operation did not finish normally. Sub-error meanings are as follows: 0001: Operation wasn't completed when the operation protection timer run out. 0012: No signal from home position sensor
Solution	[RETURN] button
Action by user	
Action by service representative	
Related part	① P-1105 [A200] ② P-1006 board for front feeder [A201] ③ Driving motor for feeder [M121] ④ Origin point of front feeder [B***]
Remarks	

■ Motor rear feeder move is abnormal (420)

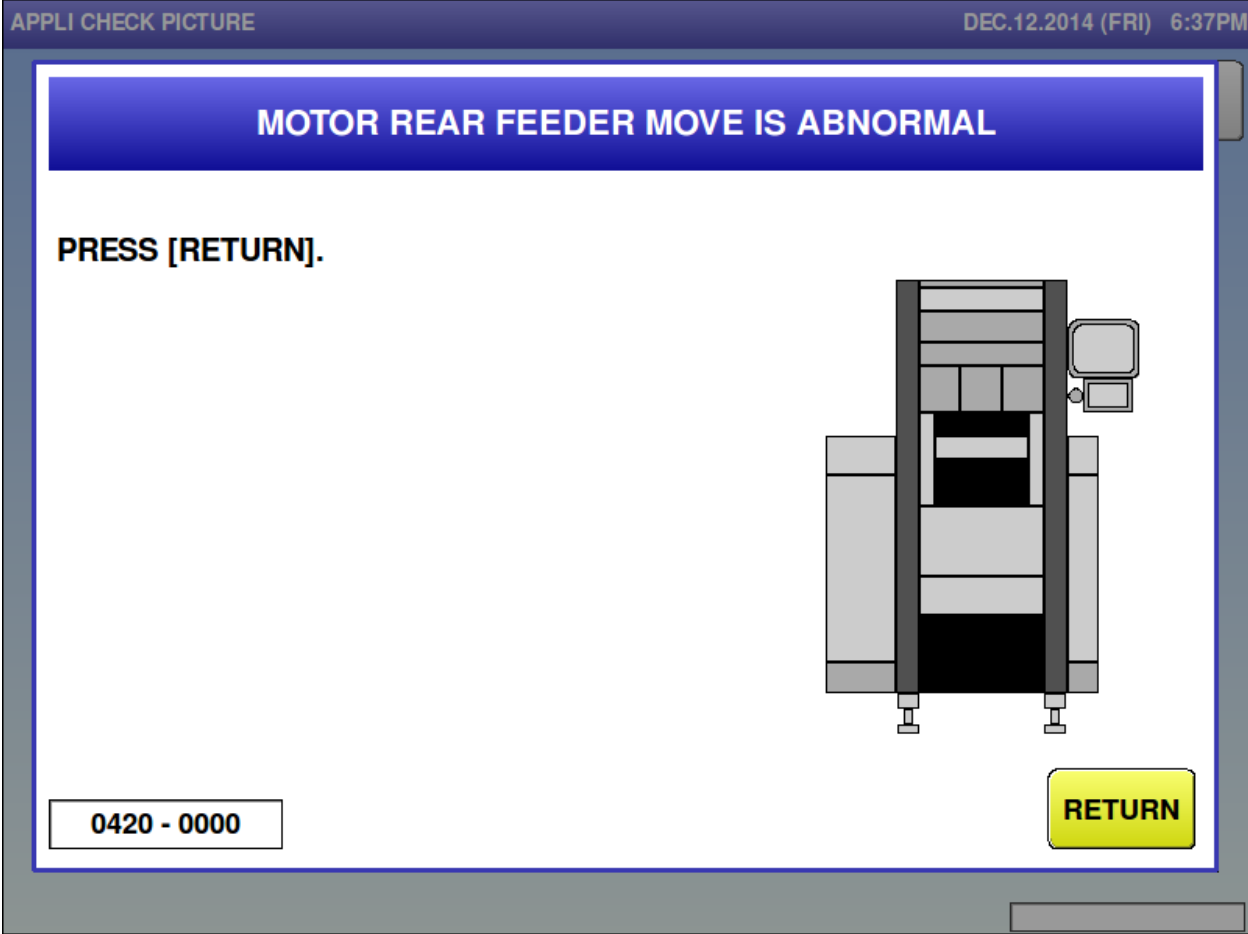

Error content	Motor rear feeder error
Detail	Motor rear feeder operation did not finish normally. Sub-error meanings are as follows: 0001: Operation wasn't completed when the operation protection timer run out. 0003: DCB motor is overloaded. 0004: Feedback pulse from DCB motor has an error (phase interruption).
Solution	[RETURN] button
Action by user	
Action by service representative	Check three rear feeder position sensors and flags located on the right side of the wrapper: B212: Home position, B217: Small Lift safety detect, and B218: Large Lift safety detect.
Related part	① P-1105 [A200] ② Driving motor for feeder [M05] ③ Origin point of rear feeder [B212]
Remarks	Rear Feeder moves to the back side and stops <ul style="list-style-type: none"> ▪ Flag under the right side is not breaking the three sensors: [B212, B217, B218] p/n 104239 ▪ Flag is thin and easily bent. ▪ Usually occurs after the feeder has been remove and reinstalled. 0420-0003 DCB Motor Overload <ul style="list-style-type: none"> ▪ Rear Film Feeder moves forward then moves to the back, hits the frame and stops. ▪ Check the film width sensor attached to the bottom of the right side of the Film Feeder: [B0207] p/n 104239

■ Infeed pusher bar motor is abnormal (421)

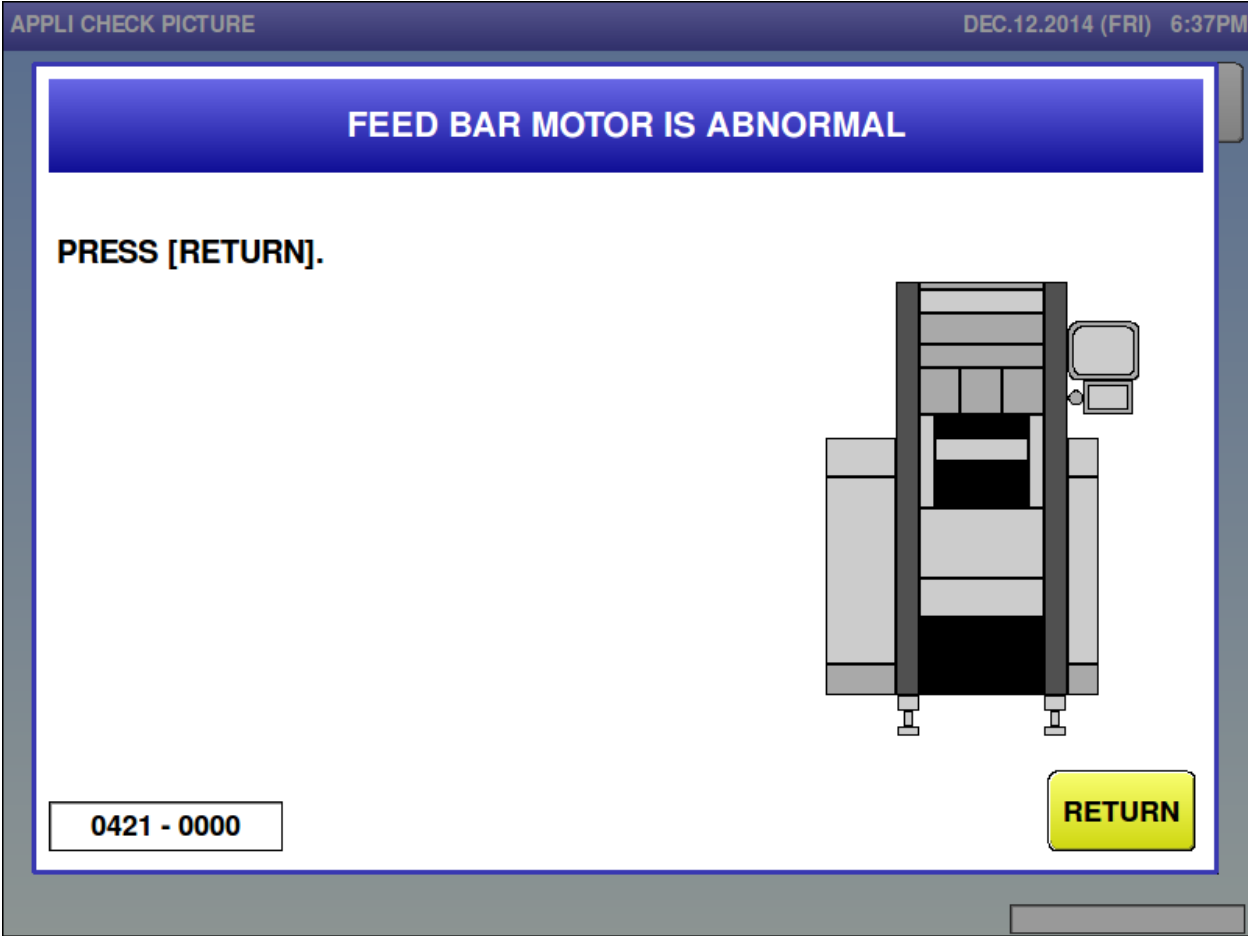

Error content	Infeed pusher bar motor error.
Detail	<p>Infeed pusher bar motor operation did not finish normally.</p> <p>Sub-error meanings are as follows:</p> <p>0001: Operation wasn't completed when the operation protection timer run out.</p> <p>0003: DCB motor is overloaded.</p> <p>0004: Feedback pulse from DCB motor has an error (phase interruption).</p> <p>0999: Back feed was performed exceeding the count limit.</p> <p>1xxx: Motor was stepped out. The "xxx" value indicates approximate location where stepping out was detected.</p> <p>3xxx: Motor torque was too high at the start of the infeed operation. The "xxx" value indicates the approximate motor stop position when the fault occurred.</p>
Solution	[RETURN] button
Action by user	
Action by service representative	
Related part	<p>① P-1105 [A200]</p> <p>② Infeed pusher bar motor [M04]</p> <p>③ Origin point of feed bar [B204]</p>
Remarks	

■ Centering motor is abnormal (422)

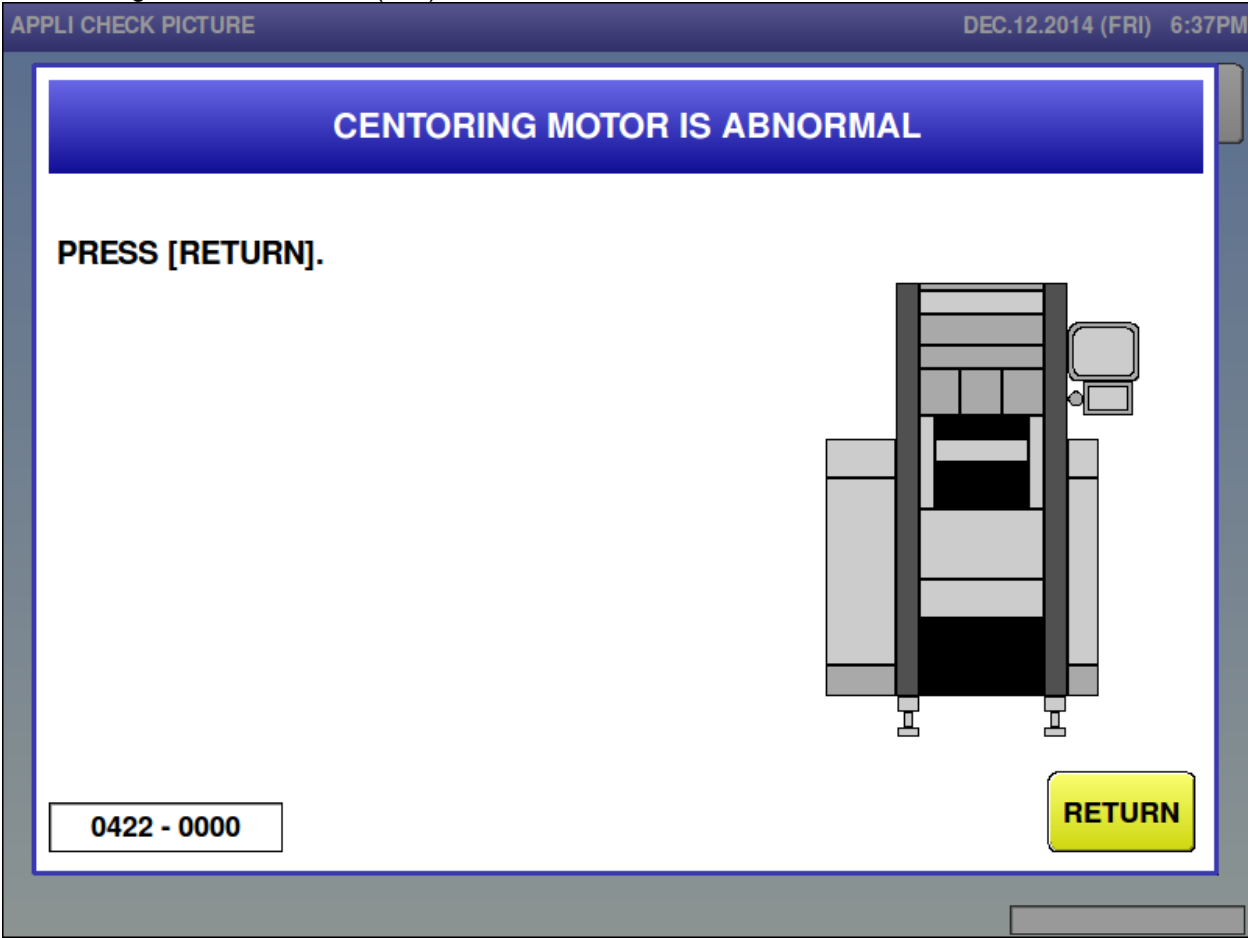

Error content	Centering motor error.
Detail	Centering motor operation did not finish normally. Sub-error meanings are as follows: 0001: Operation wasn't completed when the operation protection timer run out.
Solution	[RETURN] button
Action by user	
Action by service representative	
Related part	① P-1105 [A200] ② P-1006 board for tray press/centering [A202] ③ Centering motor [M205] ④ Centering origin [B205]
Remarks	

■ Lift change is abnormal (423)

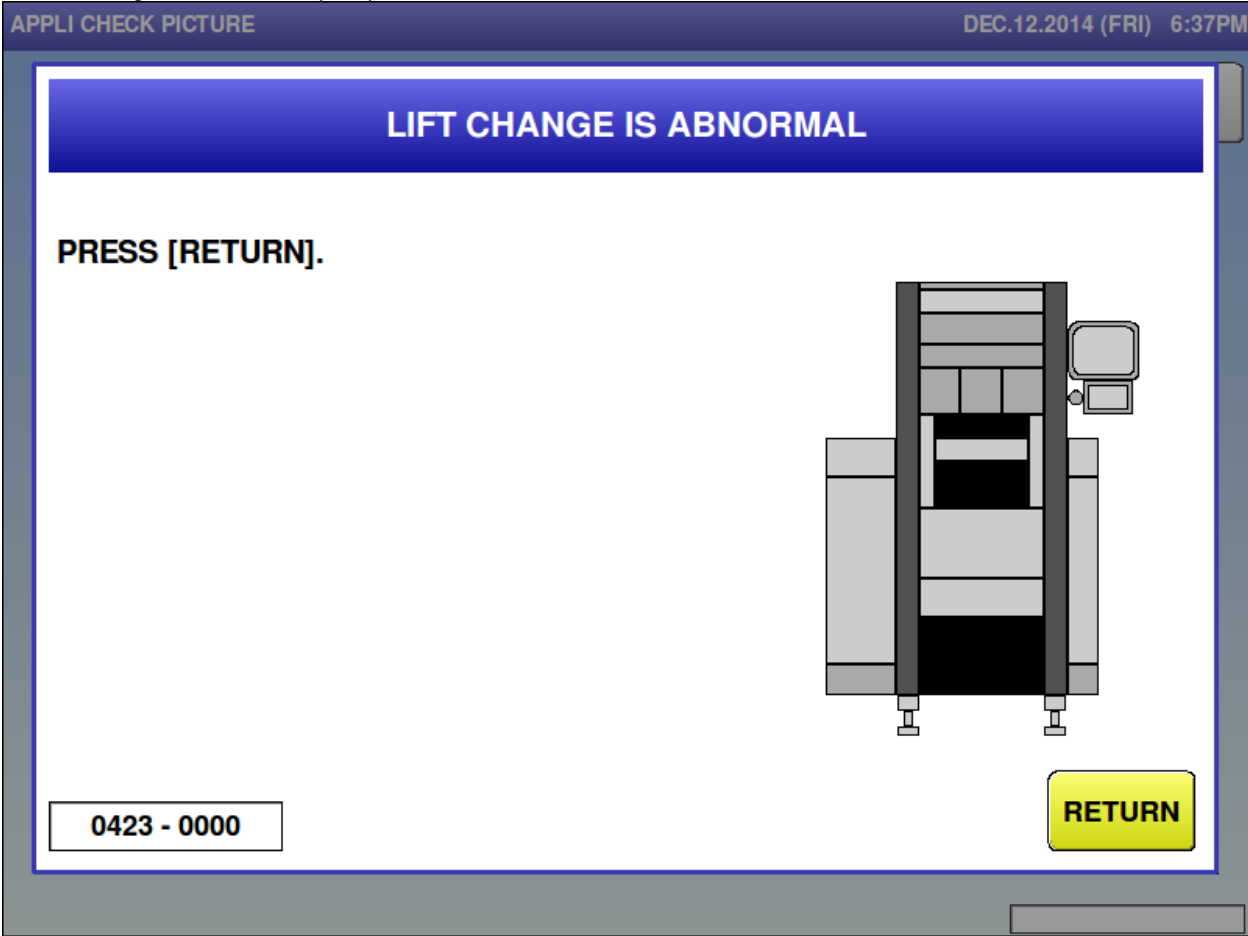

Error content	Lift change error.
Detail	Lift change operation did not finish normally. Sub-error meanings are as follows: 0003: Changeover sensor is not receiving light when lowering the lift. 0010: Operation wasn't completed during changing to small lift. 0011: Operation wasn't completed during the changing to large lift.
Solution	[RETURN] button
Action by user	
Action by service representative	
Related part	① P-1105 [A200] ② Lift change solenoid position [B214] ③ Lift change solenoid [L200]
Remarks	

■ Outfeed change motor is abnormal (424)

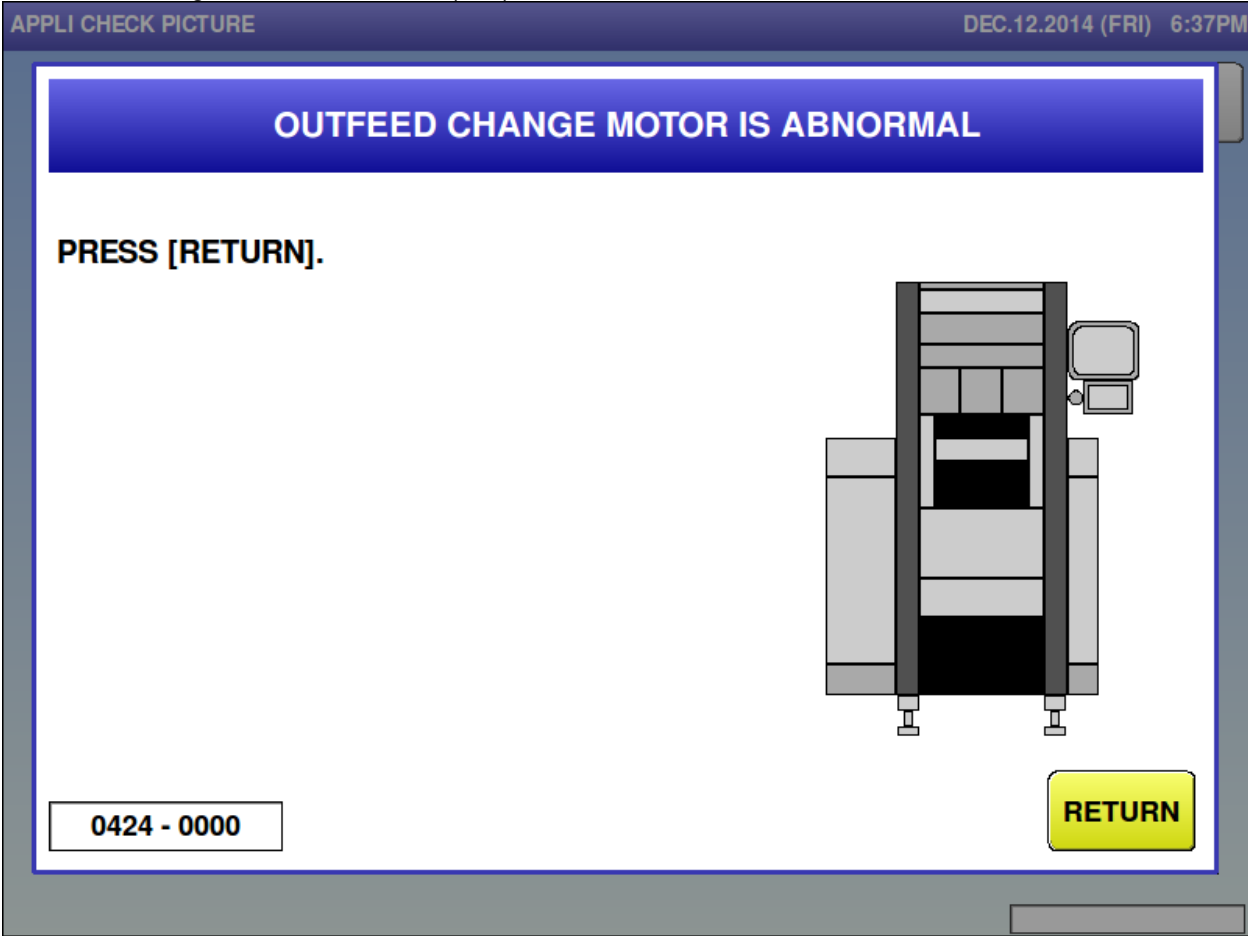

Error content	Outfeed change motor error.
Detail	An error occurred in the stock conveyor attached to the wrapper. Outfeed change motor operation did not finish normally. Sub-error meanings are as follows: 0001: Operation wasn't completed when the operation protection timer run out. 0003: DCB motor is overloaded. 0004: Feedback pulse from DCB motor has an error (phase interruption).
Solution	[RETURN] button
Action by user	
Action by service representative	
Related part	① P-1105 [A300] ② Driving motor for outfeed conveyor [M07]
Remarks	

■ Film heater has problem (426)

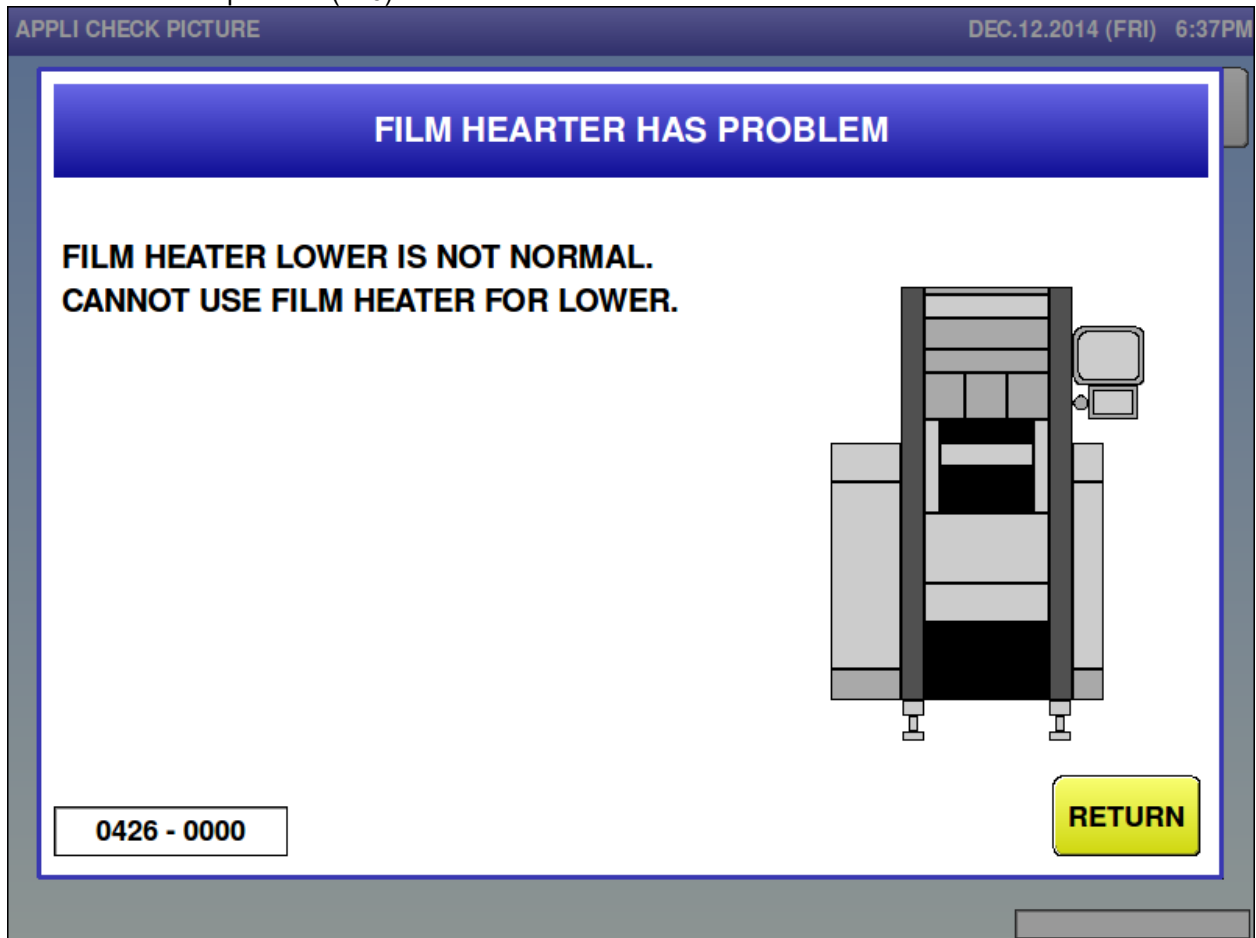

Error content	Film heater error.
Detail	As an error occurs in film heater, unable to use the heater. Sub-error meanings are as follows: 0001: Thermistor of film heater is disconnected. 0100: A fan alarm occurs (alarm also occurs when connector is not inserted).
Solution	[RETURN] button
Action by user	
Action by service representative	
Related part	① P-1105 [A300] ② Thermistor for film heater [R300] ③ Fan for film heater [M305]: Sub-error is 100
Remarks	After the error occurrence, unable to use the left side film heater.

■ Something is stuck underneath of lift (434)

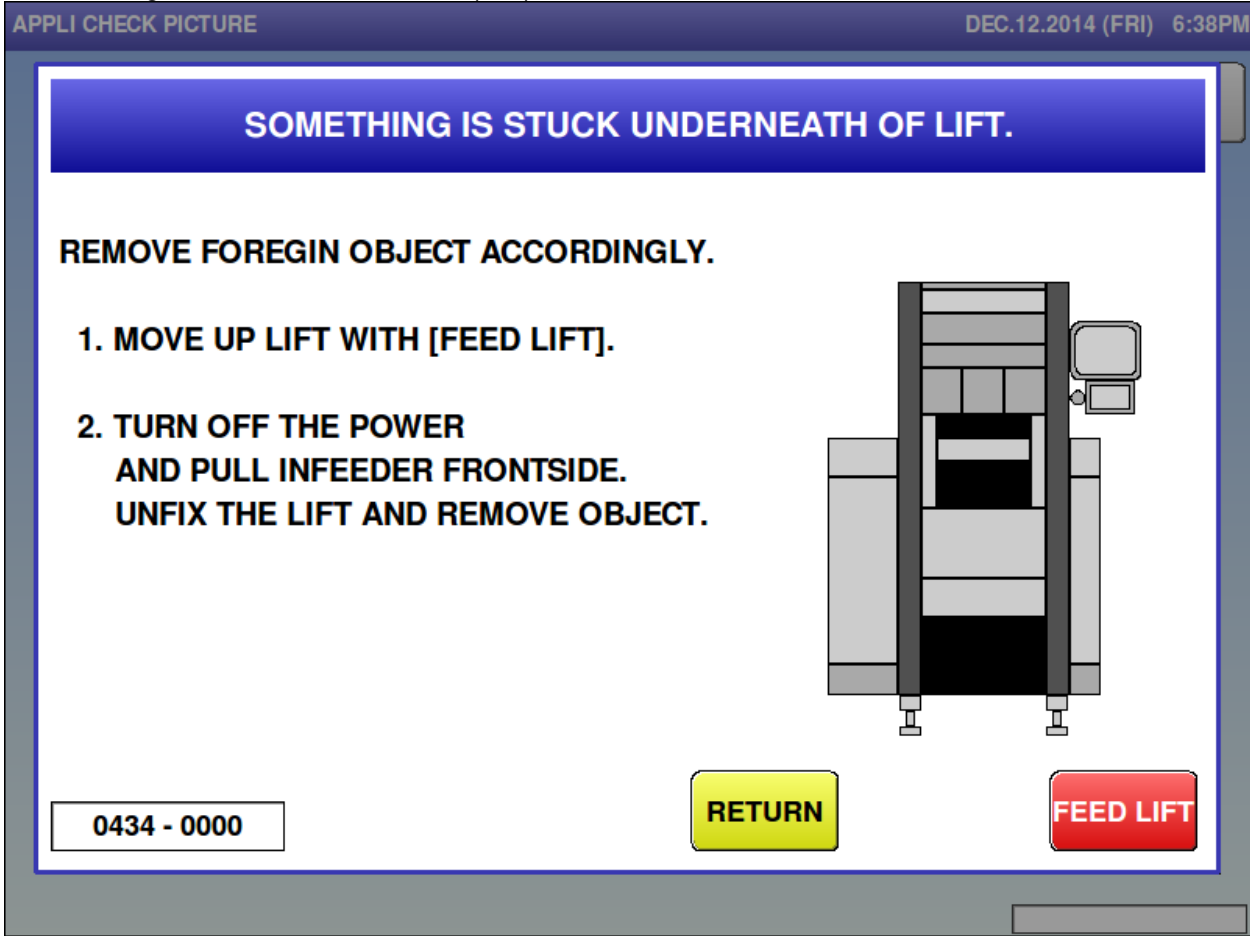

Error content	An object is caught under the lift.
Detail	Occurs when an overload of lift motor is detected caused by an object caught under the lift. 0000: Operation speed of lift motor is down. 0001: Operation wasn't completed after 5 second since the lift motor has operated.
Solution	[RETURN] button => Restore operation Lift inching => Lift inching operation
Action by user	
Action by service representative	
Related part	① P-1105 [A200] ② Motor for lift [M06] ③ Lift origin point [B200]
Remarks	Use lift inching to get rid of something caught under the lift.

■ Motor voltage is abnormal (435)

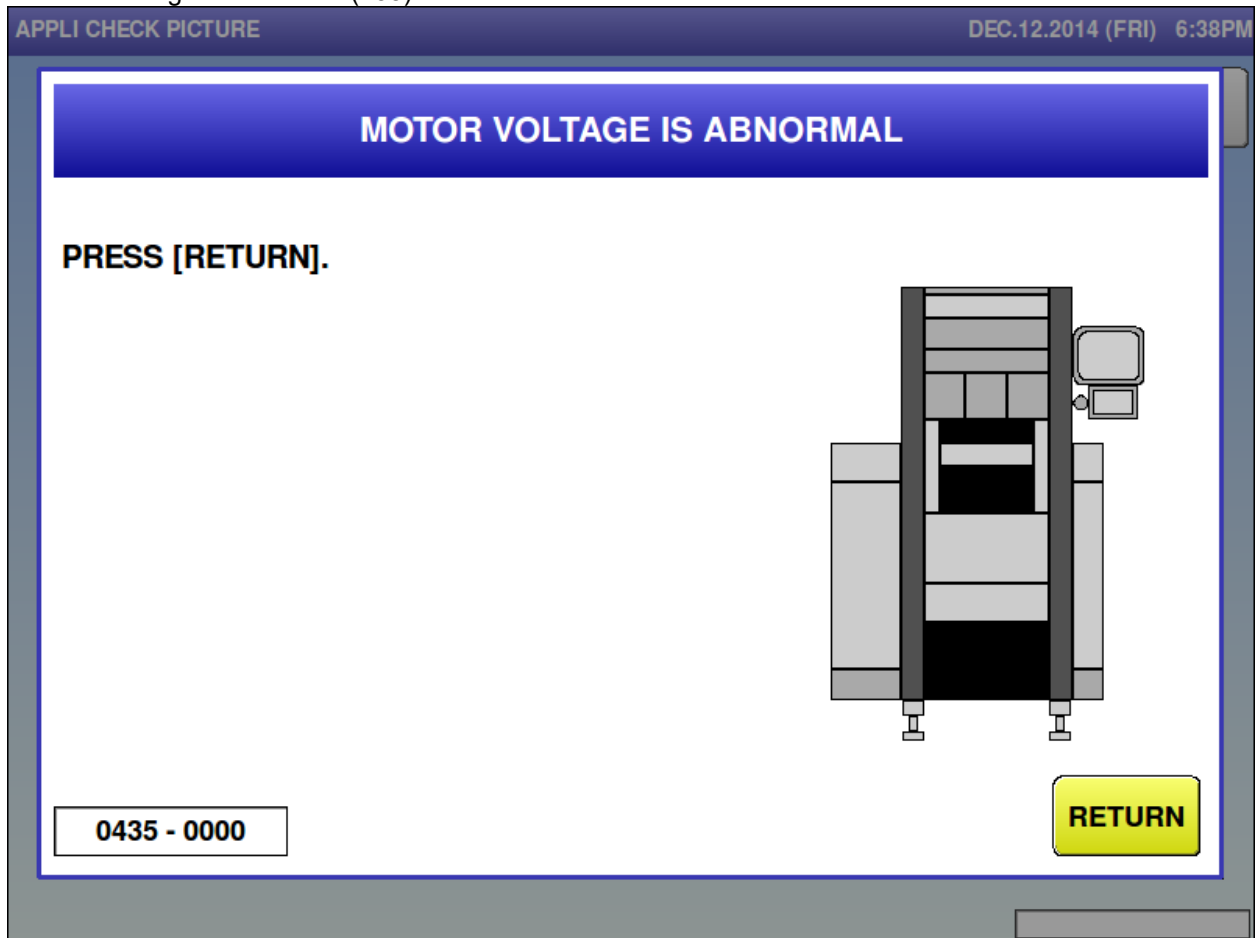

Error content	Power supply voltage error.
Detail	Occurs when voltage error is detected in the P-1105 board. Sub-error meanings are as follows: 0001: Undervoltage was detected in P-1105 [A200]. 0002: Overvoltage was detected in P-1105[A200]. 0011: Undervoltage was detected in P-1105 [A100]. 0012: Overvoltage was detected in P-1105 [A100]. 0021: Undervoltage was detected in P-1105 [A300]. 0022: Overvoltage was detected in P-1105 [A300].
Solution	[RETURN] button
Action by user	
Action by service representative	
Related part	① Confirm the power supply of input power 200 to 240 V AC. ② P-1105 [A100, A200, A300]
Remarks	

■ Emergency stop has been pushed (440)

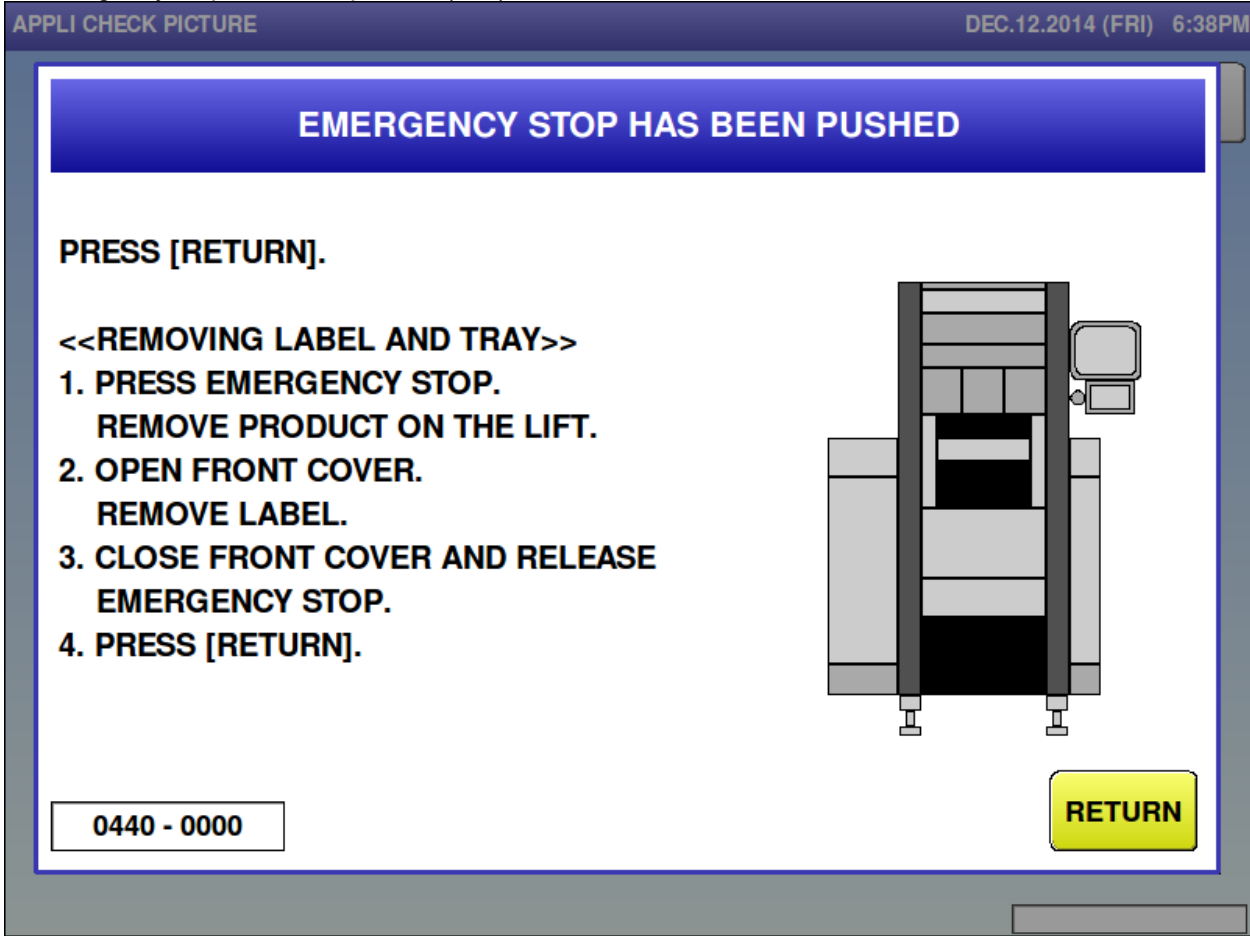

Error content	Emergency stop has been pushed during operation.
Detail	Occurs when the emergency stop switch is pushed while the wrapper is operating.
Solution	Press the [RETURN] button after releasing the emergency stop switch.
Action by user	
Action by service representative	
Related part	
Remarks	

■ Film remove cover is open (441)

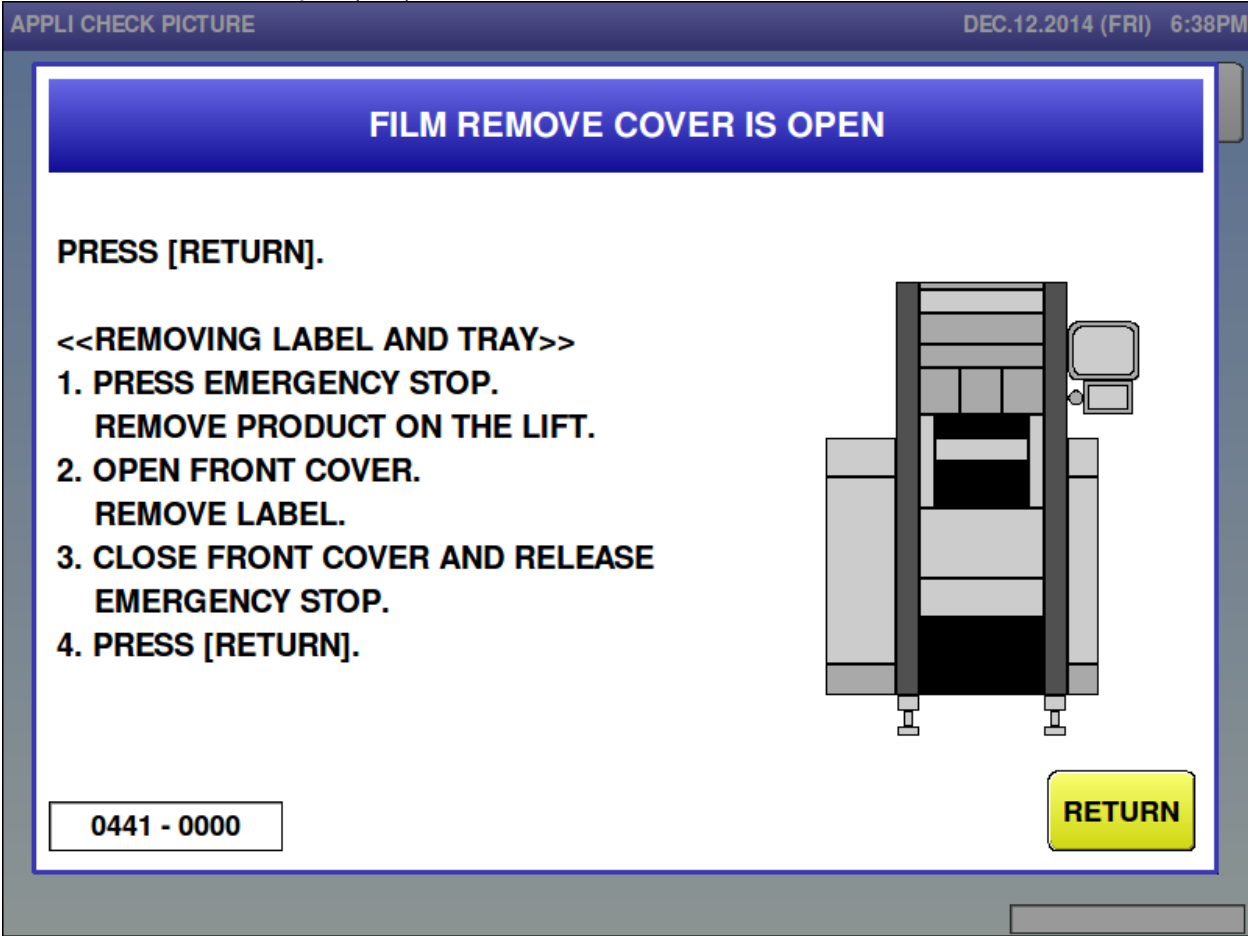

Error content	The right film remove cover was opened during operation.
Detail	Occurs when the right film remove cover is opened while the wrapper is operating.
Solution	Press the [RETURN] button after closing the right film remove cover.
Action by user	
Action by service representative	
Related part	
Remarks	

■ Film exchange cover is open (444)

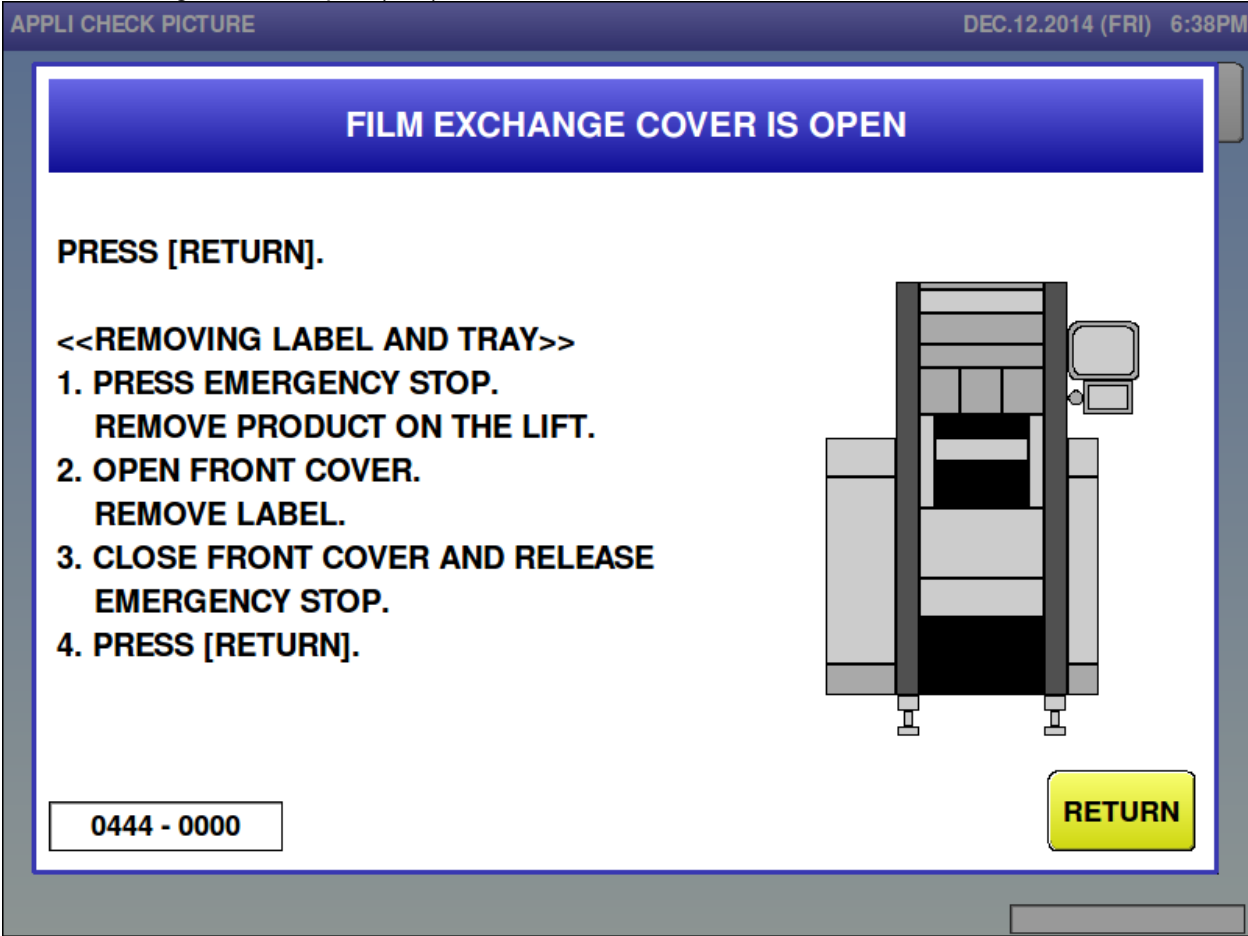

Error content	The left film exchange cover was opened during operation.
Detail	Occurs when the left film exchange cover is opened while the wrapper is operating.
Solution	Press the [RETURN] button after closing the left film exchange cover.
Action by user	
Action by service representative	
Related part	
Remarks	

■ Front cover is opened (445)

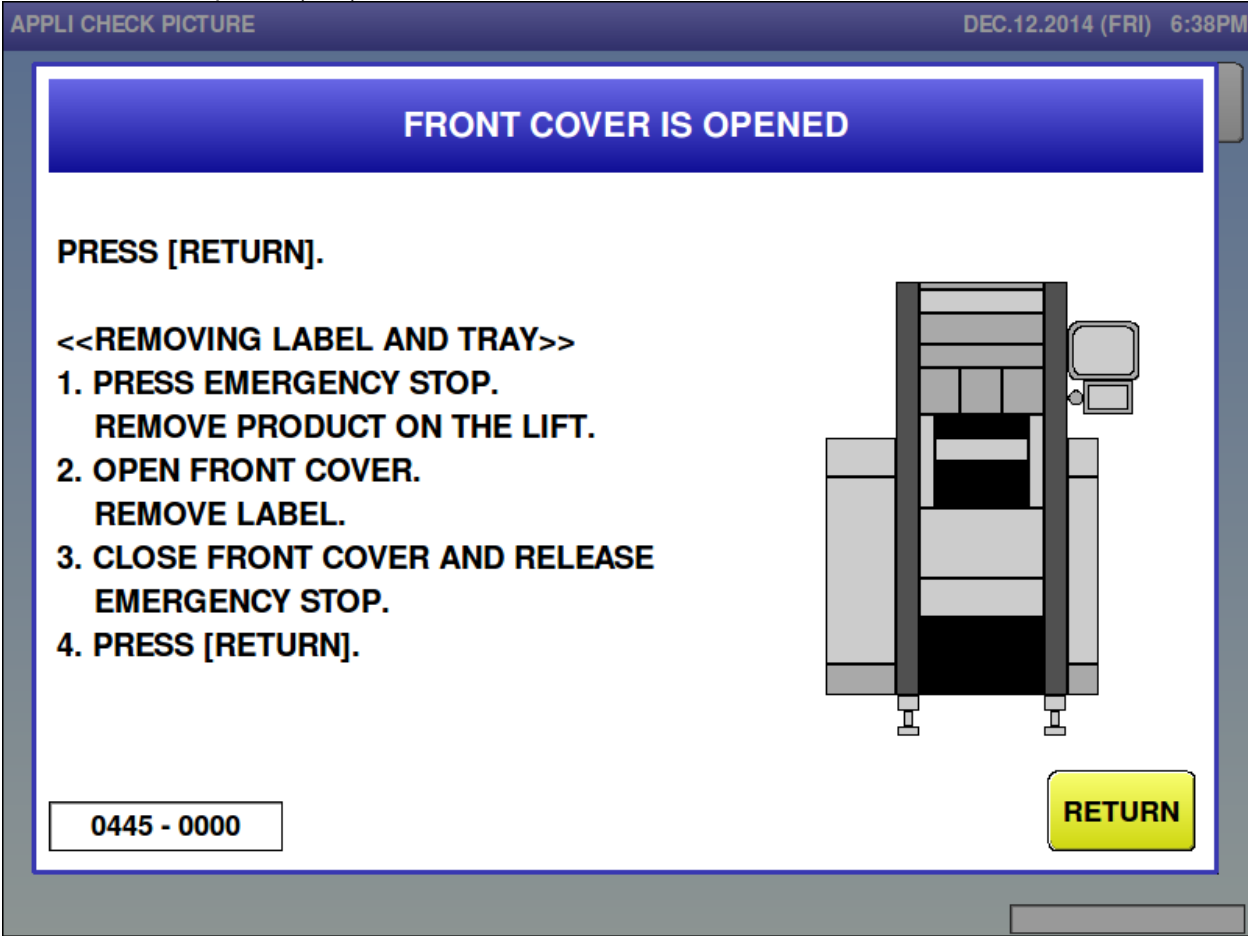

Error content	The front cover was opened during operation.
Detail	Occurs when Front cover is opened while the wrapper is operating.
Solution	Press the [RETURN] button after closing the front cover.
Action by user	
Action by service representative	
Related part	
Remarks	

■ Infeed conveyor is out (447)

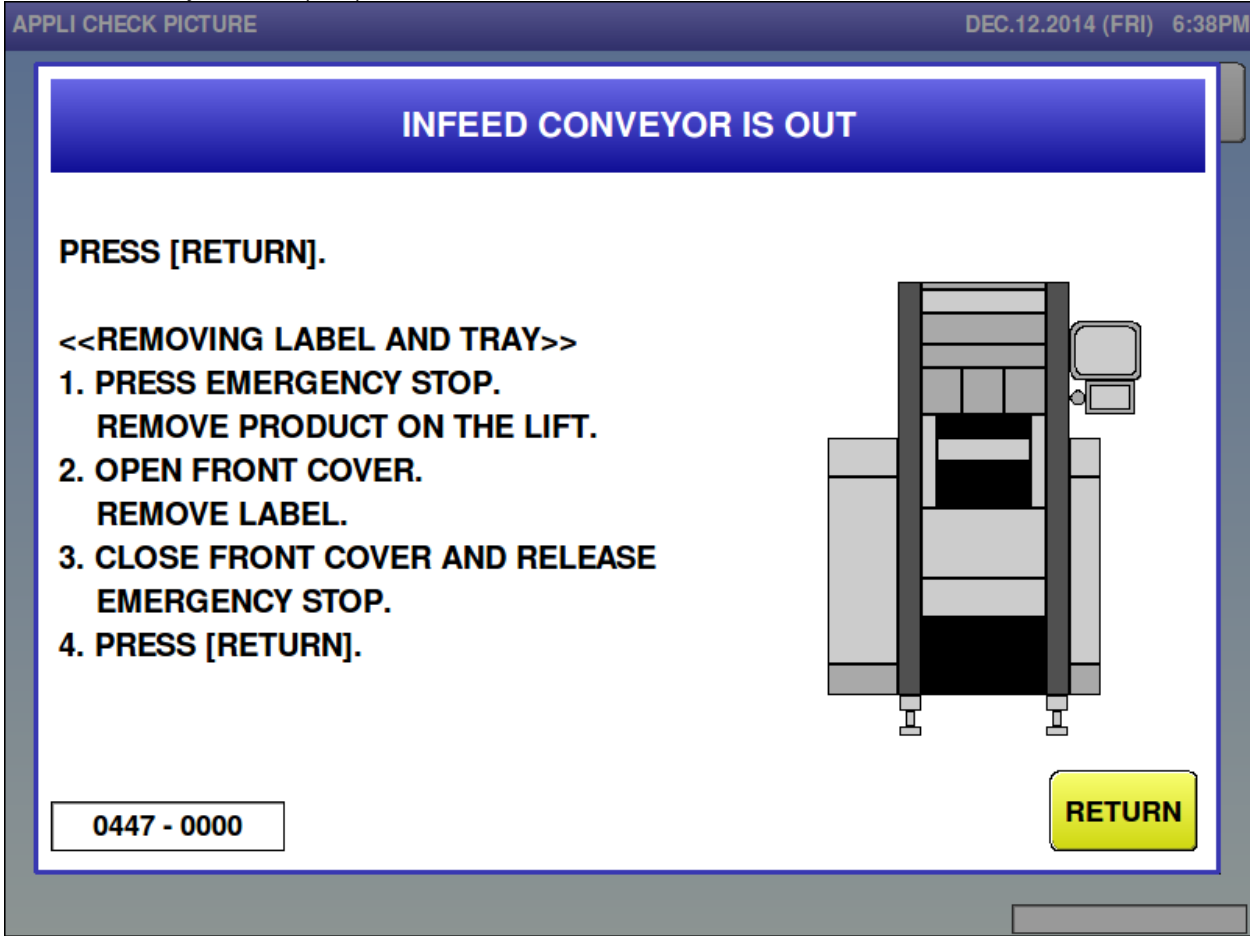

Error content	The infeed conveyor bottom cover was opened during operation.
Detail	Occurs when the infeed conveyor bottom cover is opened while the wrapper is operating
Solution	Press the [RETURN] button after setting the infeed conveyor cover.
Action by user	
Action by service representative	
Related part	
Remarks	

- Do not put your hands into the machine (448)

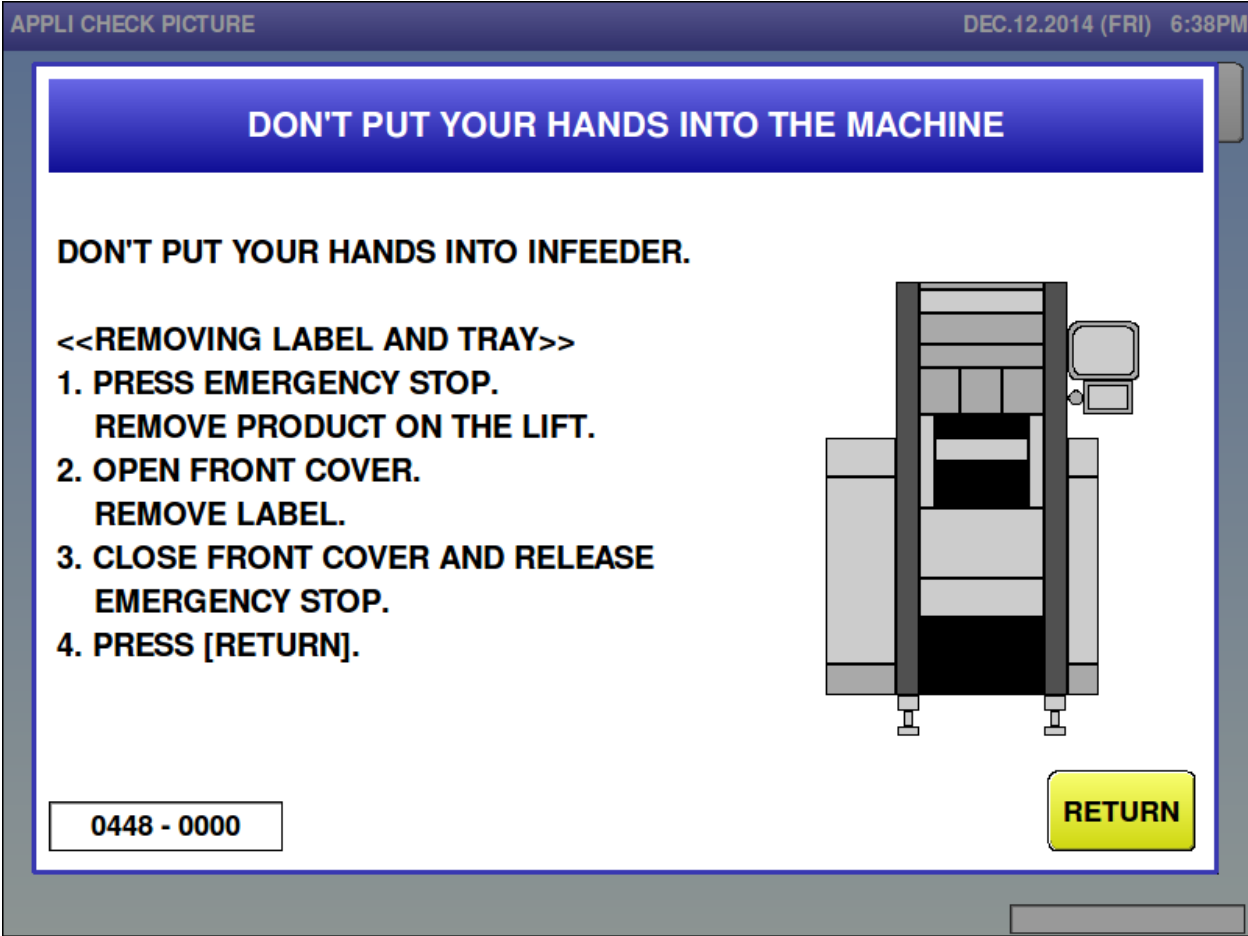

Error content	A hand was put into the wrapper during operation.
Detail	Occurs when a hand or object is detected entering the infeed conveyor while the wrapper is operating. 0000: A hand is detected entering the infeed conveyor in forward side. 0001: A hand is detected entering the infeed conveyor in backward side
Solution	[RETURN] button
Action by user	
Action by service representative	1. Clean Hand insertion sensors [B215, B216]. 2. Check Hand insertion sensors [B215, B216] in Adjust menu > Unit Action > Sensor Check.
Related part	① P-1105 [A200] - consider the board only after cleaning or replacing the sensors. ② Hand insertion in the infeed conveyor <upper front side> (light receiving/emitting) L: [B215] R: [B215T] ③ Hand insertion in the infeed conveyor <lower rear side> (light receiving/emitting) R: [B216] L: [B216T]
Remarks	Press the [RETURN] button after making sure a hand or object is not in the wrapper. B215, B216: p/n 125712 B215T, B216T: p/n 125711 Sensor cover: p/n 189254

- Do not put your hands into the machine (449)

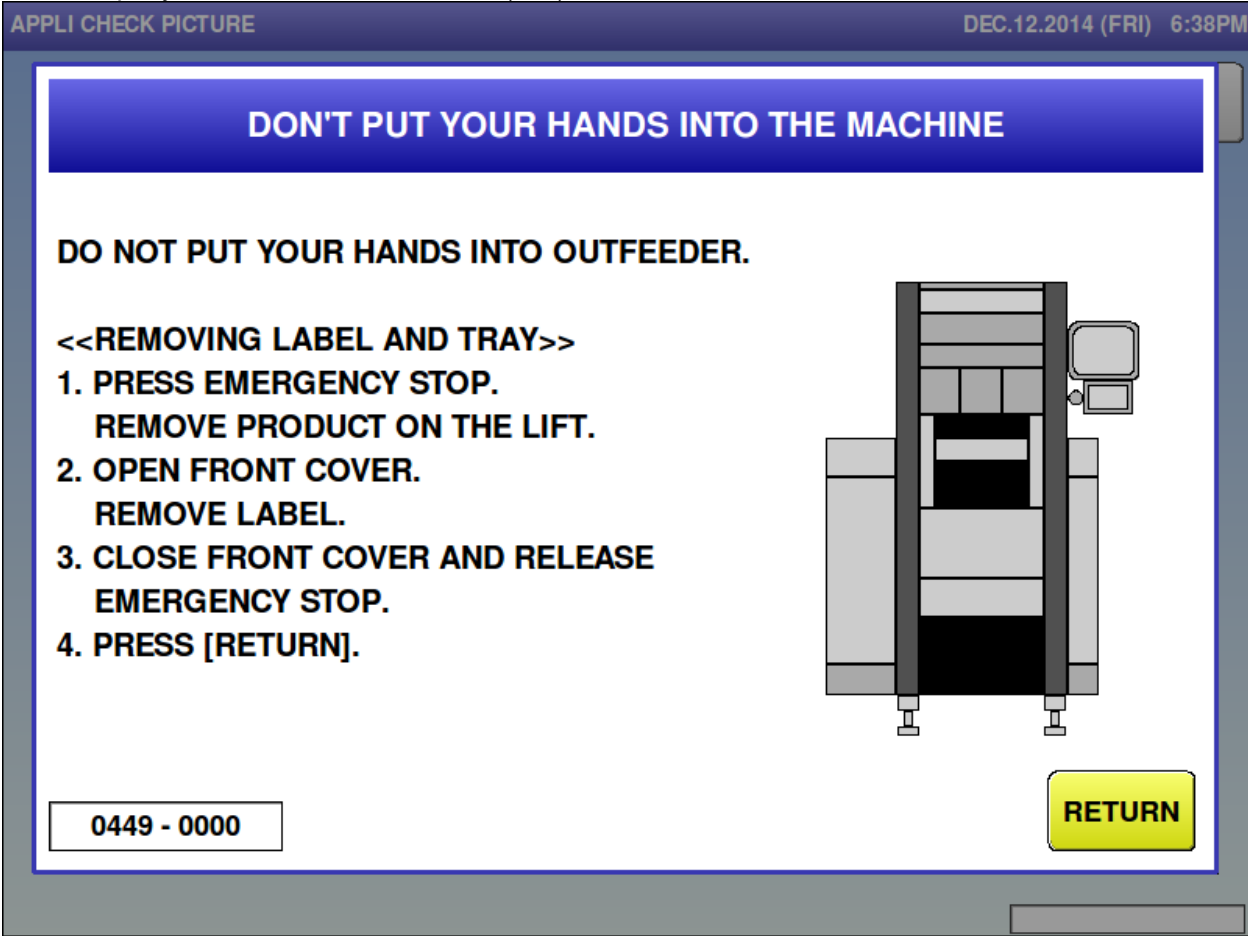

Error content	A hand was put into the wrapper during operation.
Detail	Occurs when a hand or object is detected entering the discharge area while the wrapper is operating. Sub-error meanings are as follows: 0000: Detected by a sensor located over the outfeed seal heater. 0001: Detected by a sensor located under the printer door cover.
Solution	Press the [RETURN] button after making sure a hand or object is not placed.
Action by user	
Action by service representative	① Clean Hand insertion sensors [B106, B107]. ② Check Hand insertion sensors [B106, B107] in Adjust menu > Unit Action > Sensor Check.
Related part	① P-1105 [A100] - consider the board only after cleaning or replacing the sensors. ② Hand insertion at the outfeeder (light receiving/emitting) L: [B106] R: [B106T] : Sub-error is 0000. ③ Hand insertion below the front print cover (light receiving/emitting) R: [B107] L: [B107T] : Sub-error is 0001.
Remarks	Press the [RETURN] button after making sure a hand or object is not in the wrapper. B106, B107: p/n 125712. B106T, B107T: p/n 125711.

- Machine is returning to standby position (459—0000)

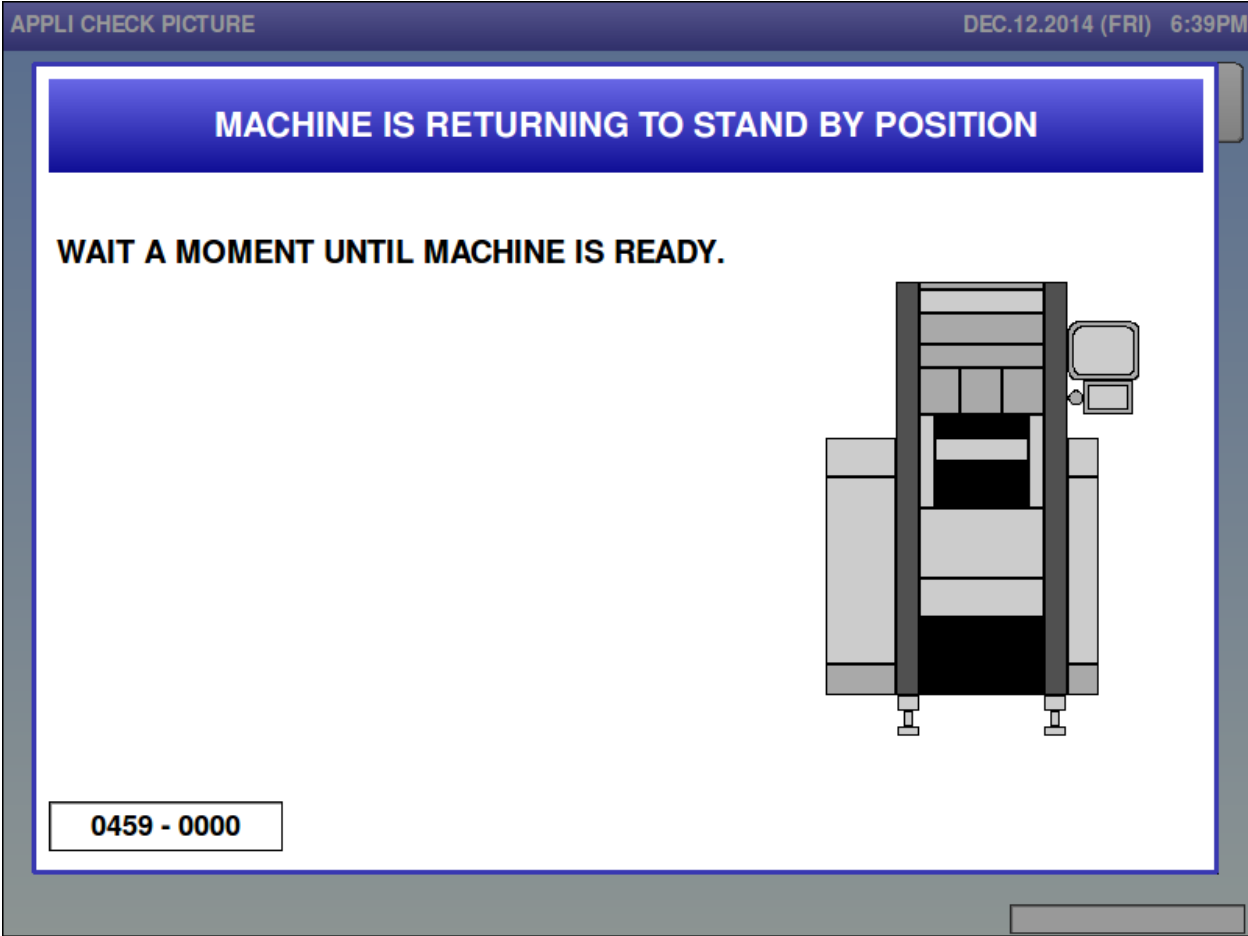

Error content	Machine is returning to standby position.
Detail	Message indicates that the wrapper is during the returning operation.
Solution	
Action by user	
Action by service representative	
Related part	
Remarks	

■ Machine is returning to standby position (459—9999)

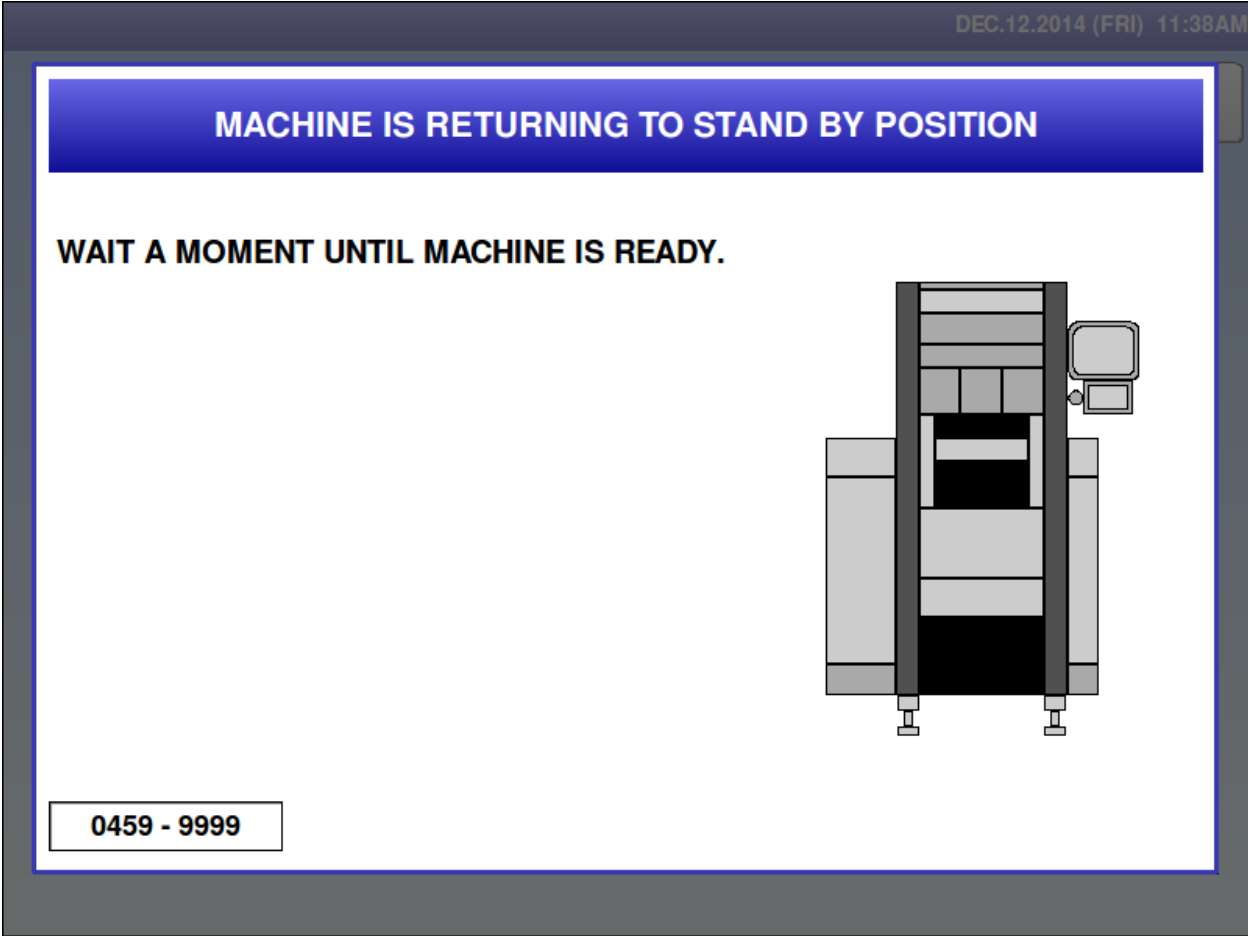

Error content	Machine is returning to standby position.
Detail	Message indicates that the wrapper is during the returning operation.
Solution	After this message, the “459—0000 “ error screen is displayed.
Action by user	
Action by service representative	
Related part	
Remarks	

■ Product was not feeded (460)

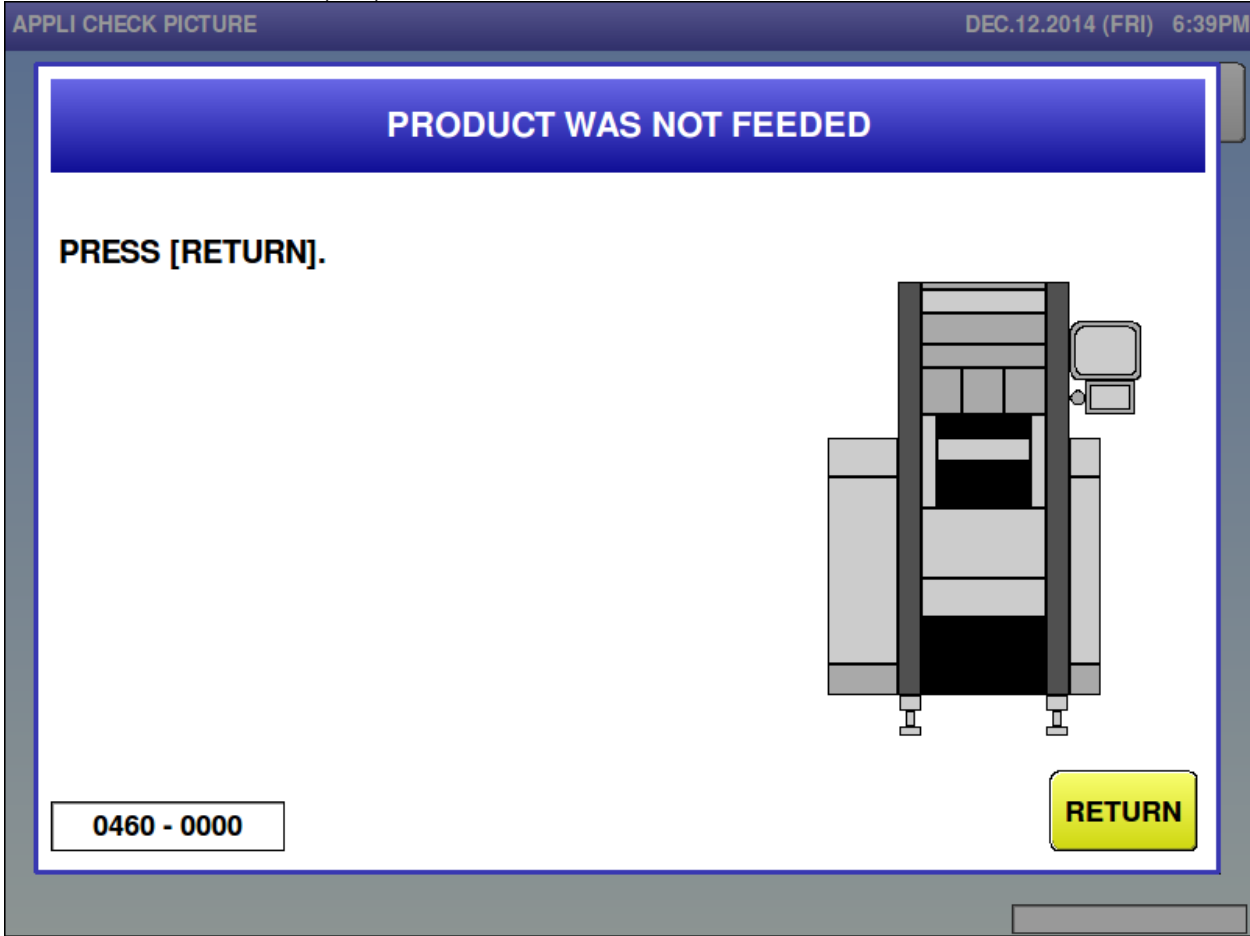

Error content	Product was not fed.
Detail	The wrapper failed to detect a product on the lift during one cycle operation. In addition, the product on the lift failed to be detected when the lift starts pushing up the product.
Solution	[RETURN] button
Action by user	
Action by service representative	
Related part	
Remarks	

- Film over error for the upper (461)
- Film over error for the lower (462)

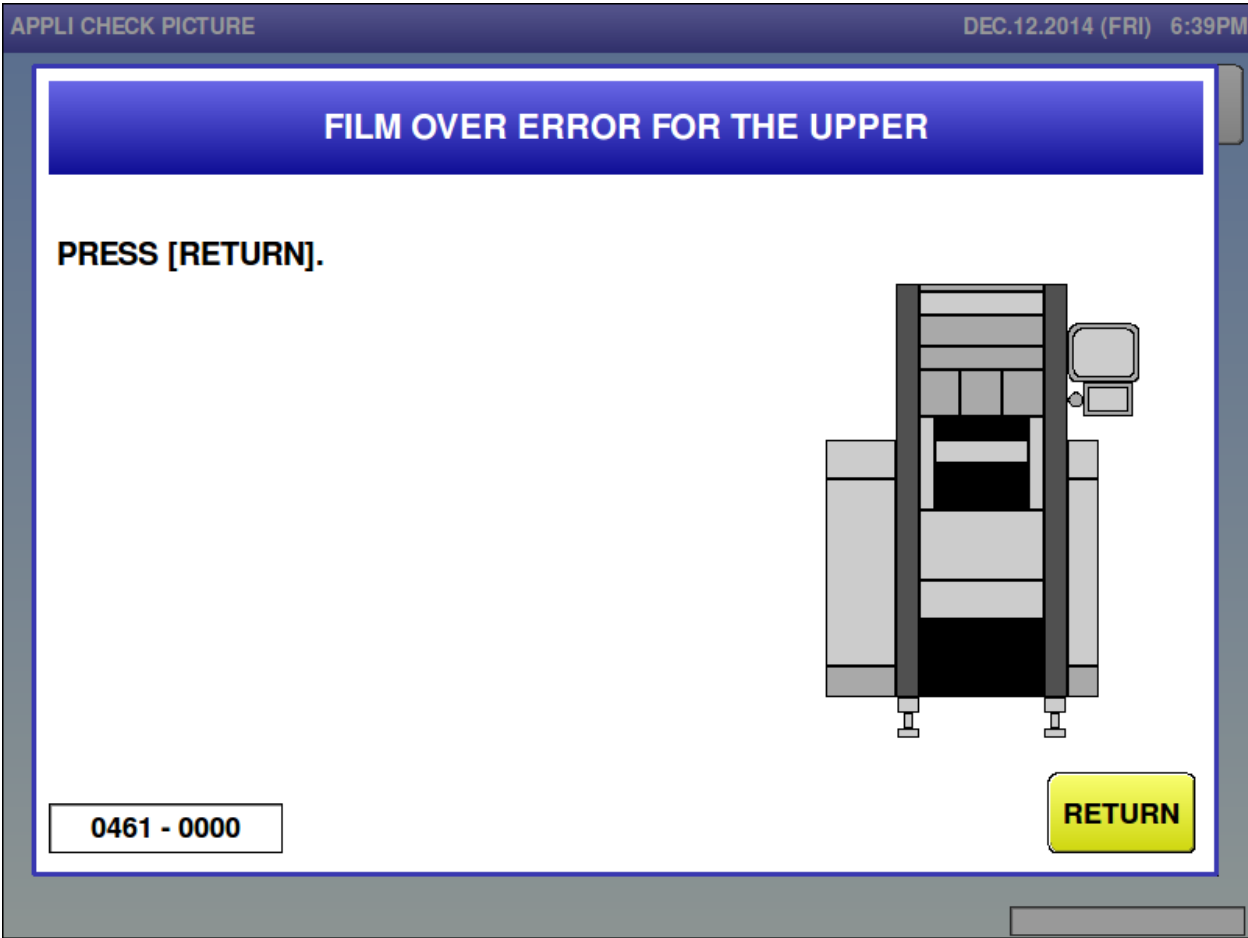

Error content	Film over error for the upper / lower.
Detail	When upper / lower film was sending, the film detection board for film over was fallen down. Sub-error meanings are as follows: 0001: During the film centering. 0002: Performing unloaded feeding. 0003: During the film feeding.
Solution	[RETURN] button
Action by user	
Action by service representative	
Related part	
Remarks	Remove film after recovery operation. <Points to be checked> ① P-1105 [A200] ② Front belt film over detector [B209]. ③ Rear belt film over detector [B211].

■ Film feeding error for the upper (465)

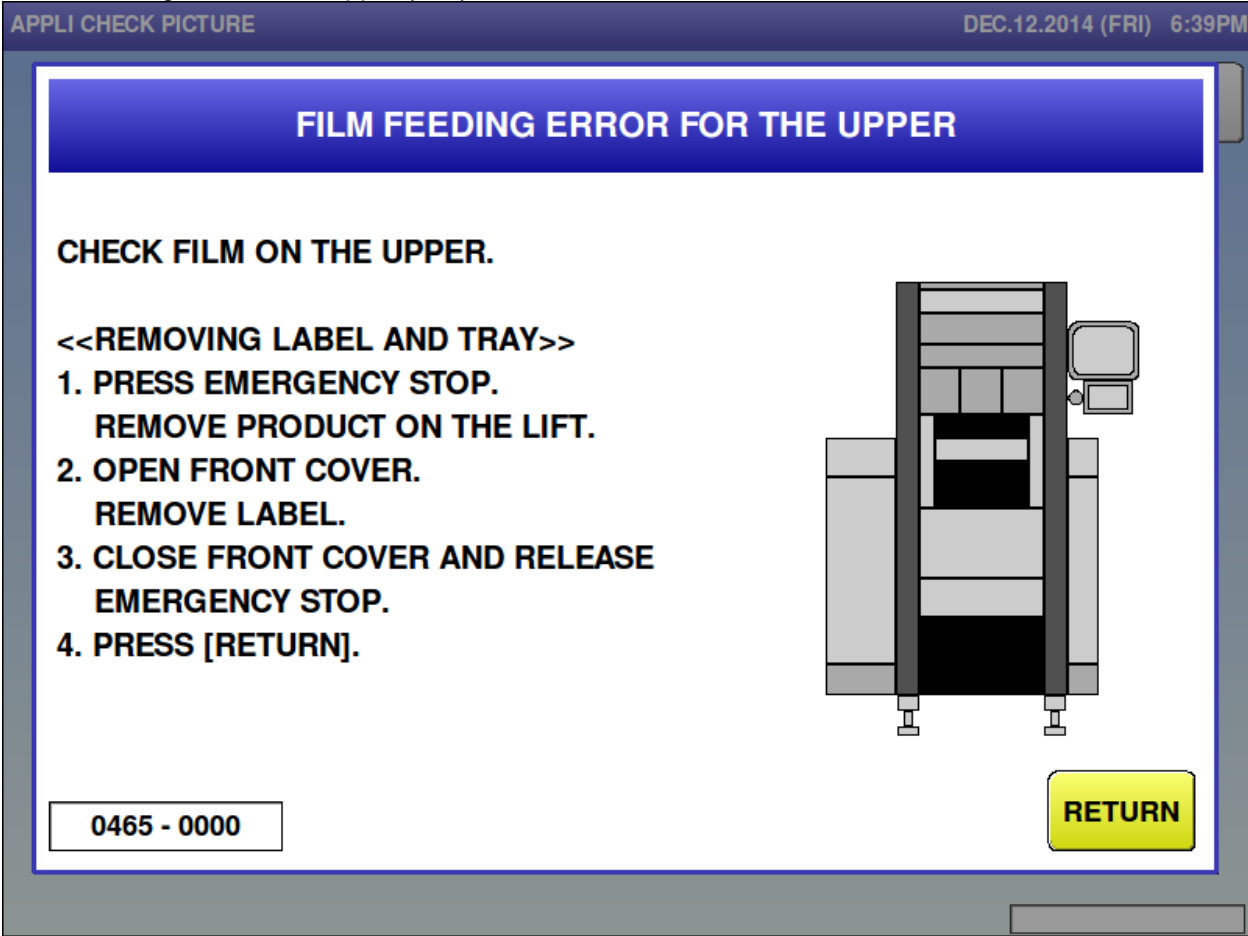

Error content	Upper film was not supplied.
Detail	upper film was sent, but the upper film detection board did not fall down. Sub-error meanings are as follows: 0XXX: Shortly before the operation, no film was changed over. 1XXX: Shortly before the operation, film was changed over. XXX indicates the external diameter of roll [mm] when an error detected. (If an error occurs by the film feeding for the first time after the film loading or the power is turned on, external diameter of roll becomes 0).
Solution	Press the [RETURN] button after checking the upper film.
Action by user	
Action by service representative	
Related part	
Remarks	The error will not be displayed by selection [No] in film error machine settings.

■ Film feeding error for the lower (466)

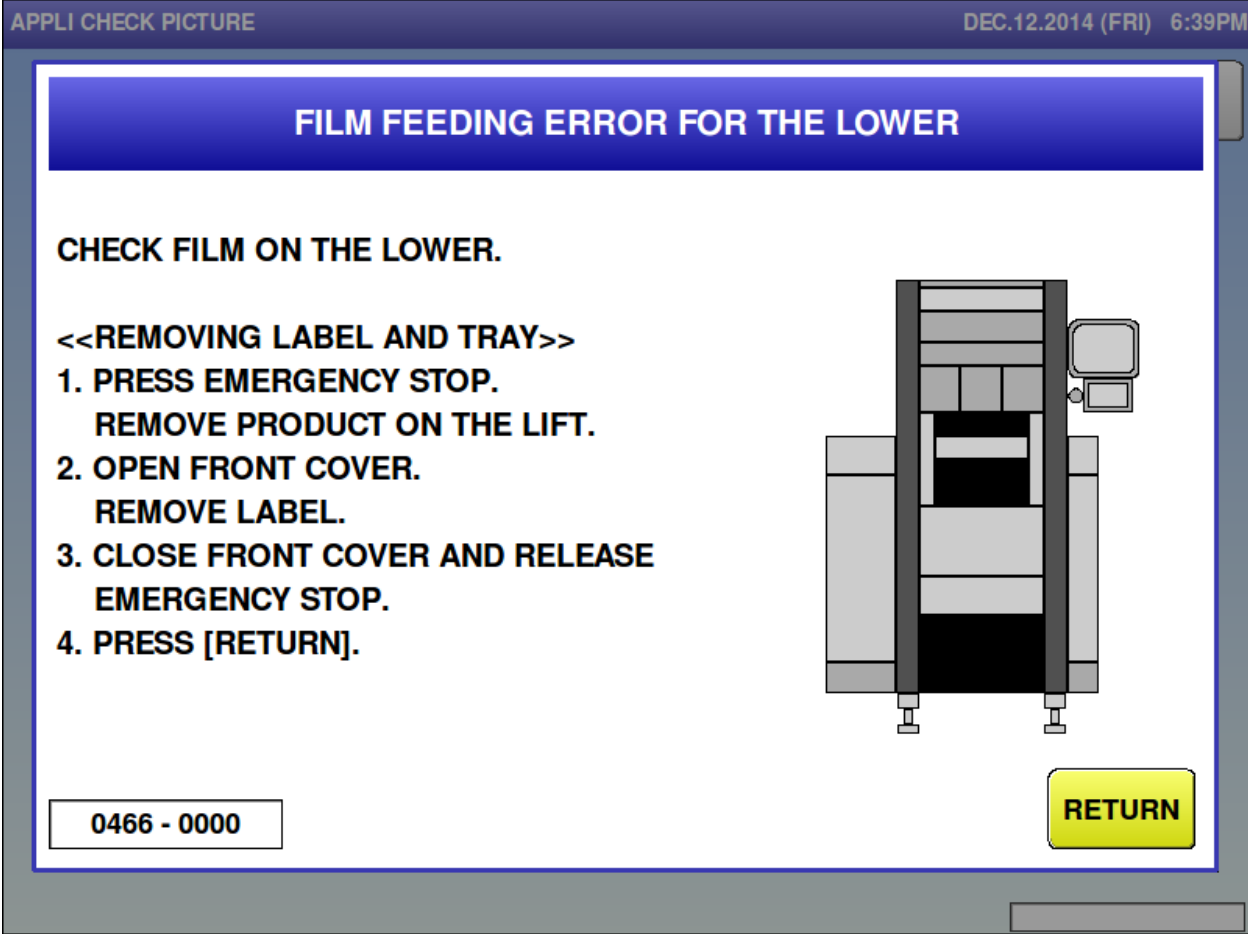

Error content	Lower film was not supplied.
Detail	Lower film was sent, but the lower film detection board did not fall down. Sub-error meanings are as follows: 0XXX: Shortly before the operation, no film was changed over. 1XXX: Shortly before the operation, film was changed over. XXX indicates the external diameter of roll [mm] when an error detected. (If an error occurs by the film feeding for the first time after the film loading or the power is turned on, external diameter of roll becomes 0).
Solution	Press the [RETURN] button after checking the lower film.
Action by user	
Action by service representative	
Related part	
Remarks	The error will not be displayed by selection [No] in film error machine settings.

■ Film loading was failed on the upper (467)

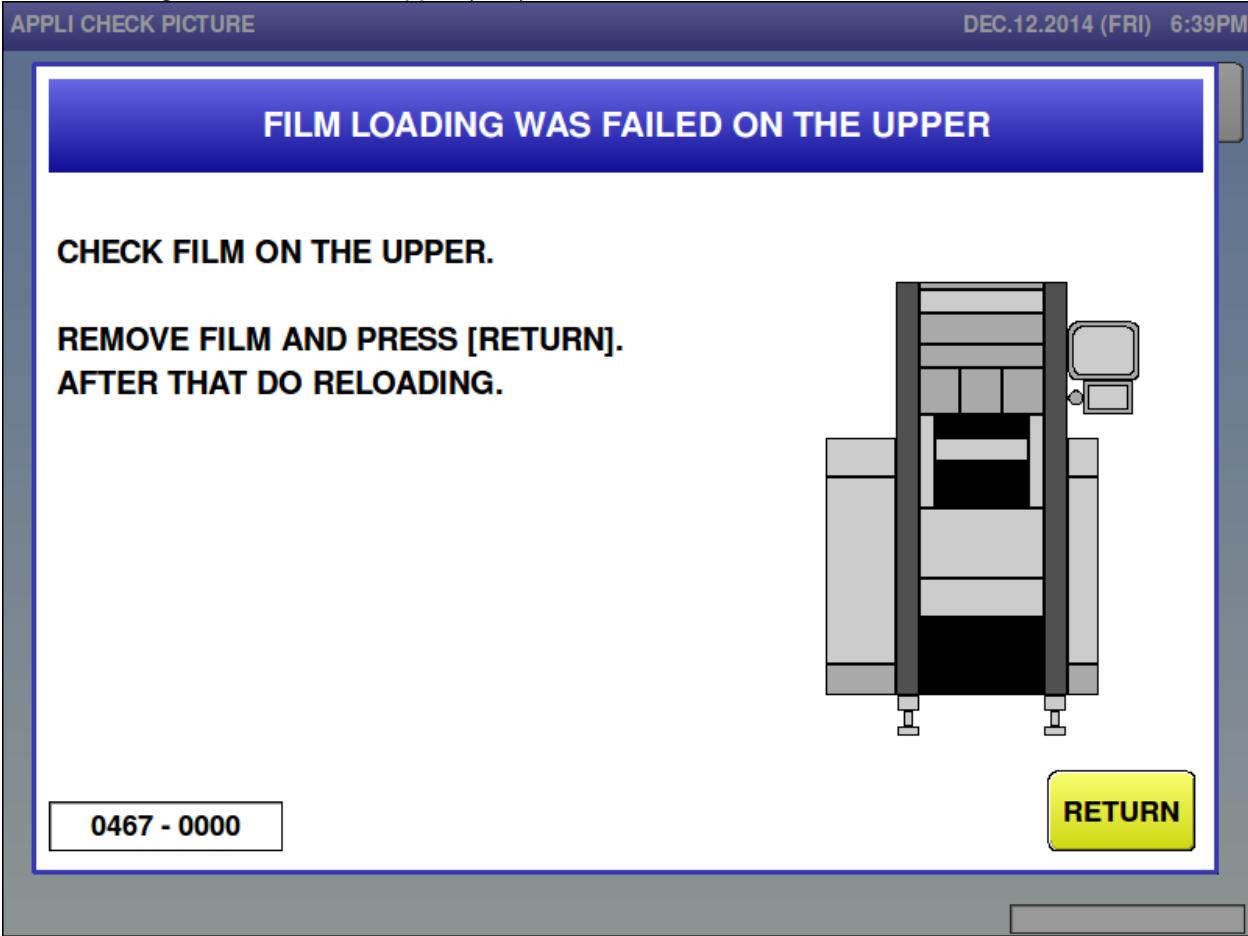

Error content	Film loading was failed on the upper.
Detail	Film transport could not compete successfully in film loading operation because send film detection board did not fall down in right order. Sub-error meanings are as follows: 0000: upper film loading failed. 0001: Lower film loading failed.
Solution	Press the [RETURN] button after removing the remaining film on the side blinking blue.
Action by user	
Action by service representative	
Related part	
Remarks	The error will not be displayed by selection [No] in film error machine settings.

- There is problem on wrapping controller (470)

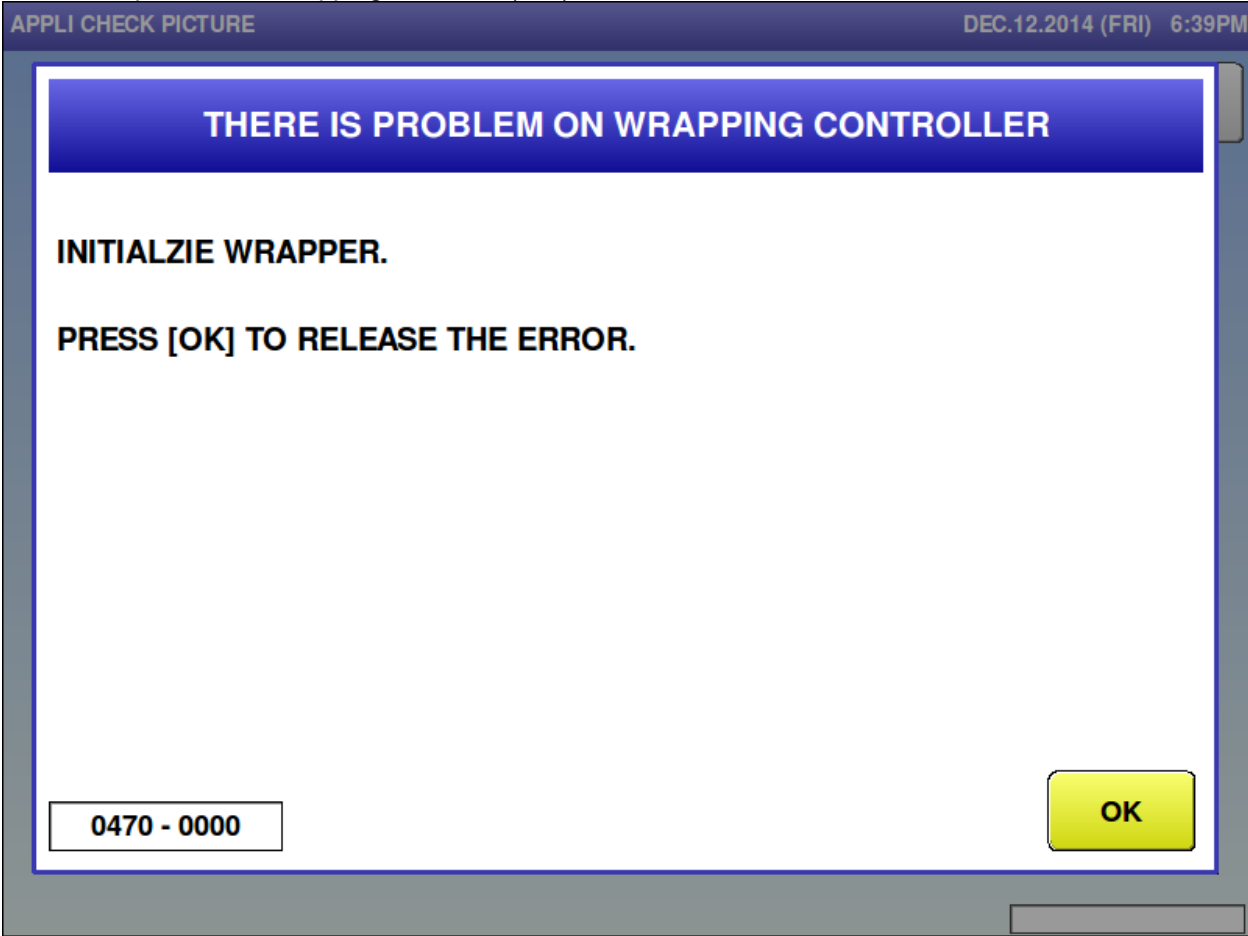

Error content	Wrapper is not initialized.
Detail	Wrapper E2ROM is not initialized (Stored E2ROM checksum error).
Solution	[OK] button
Action by user	
Action by service representative	
Related part	
Remarks	Initialize wrapper in test mode wrapper settings after canceling the error. If available, press the [RESTORE] button to reload the P-1105 board.

- There is problem on wrapping controller (471)

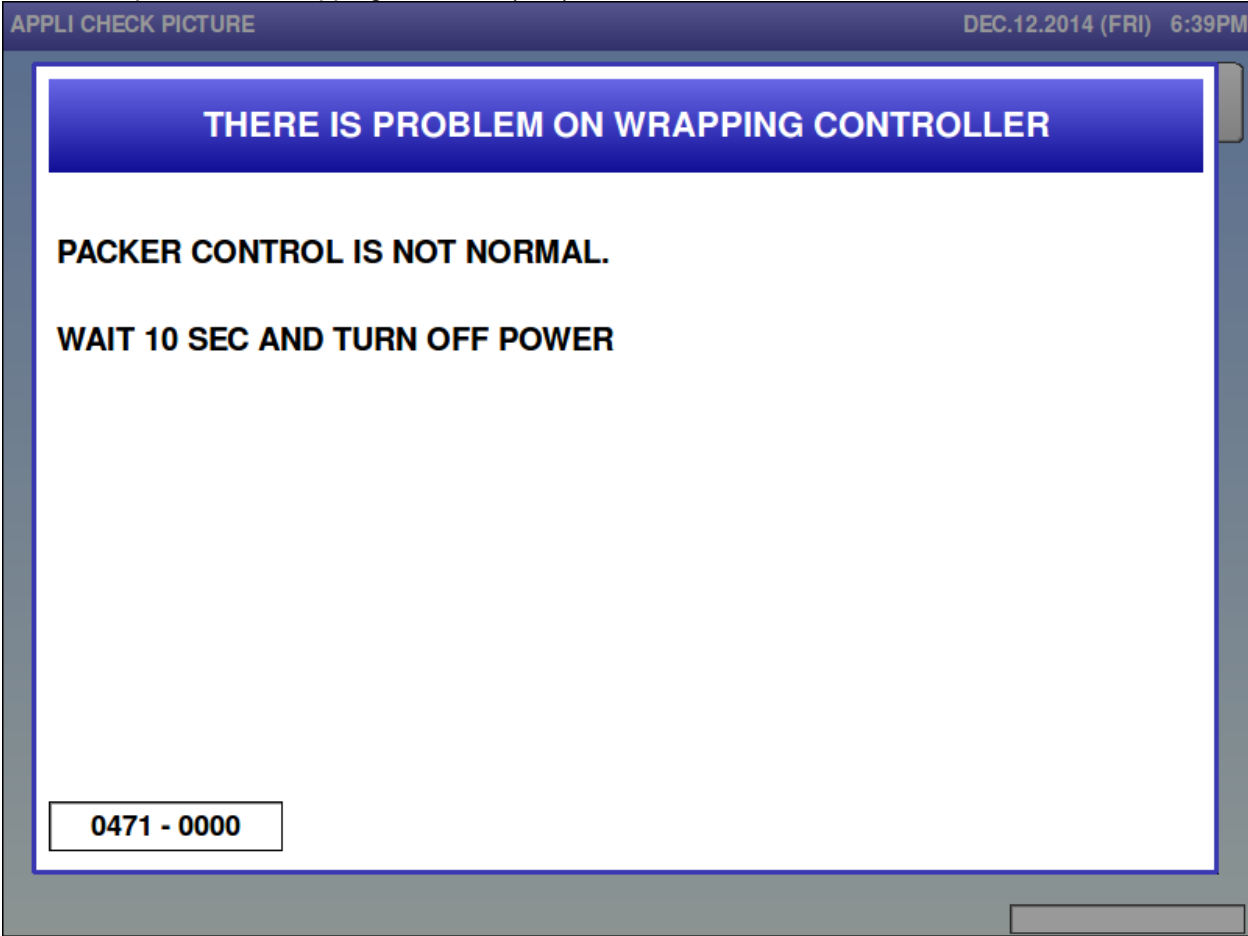

Error content	Wrapper control board is abnormal.
Detail	An error occurred in the wrapper control board. Sub-error meanings are as follows: 0003: E2ROM writing error. 0088: IC for general-purpose communication error. 0999: High speed, external CPU reset interrupt.
Solution	
Action by user	
Action by service representative	
Related part	P-1105 [A100, A200, A300]
Remarks	

- There is problem on wrapping controller (472)

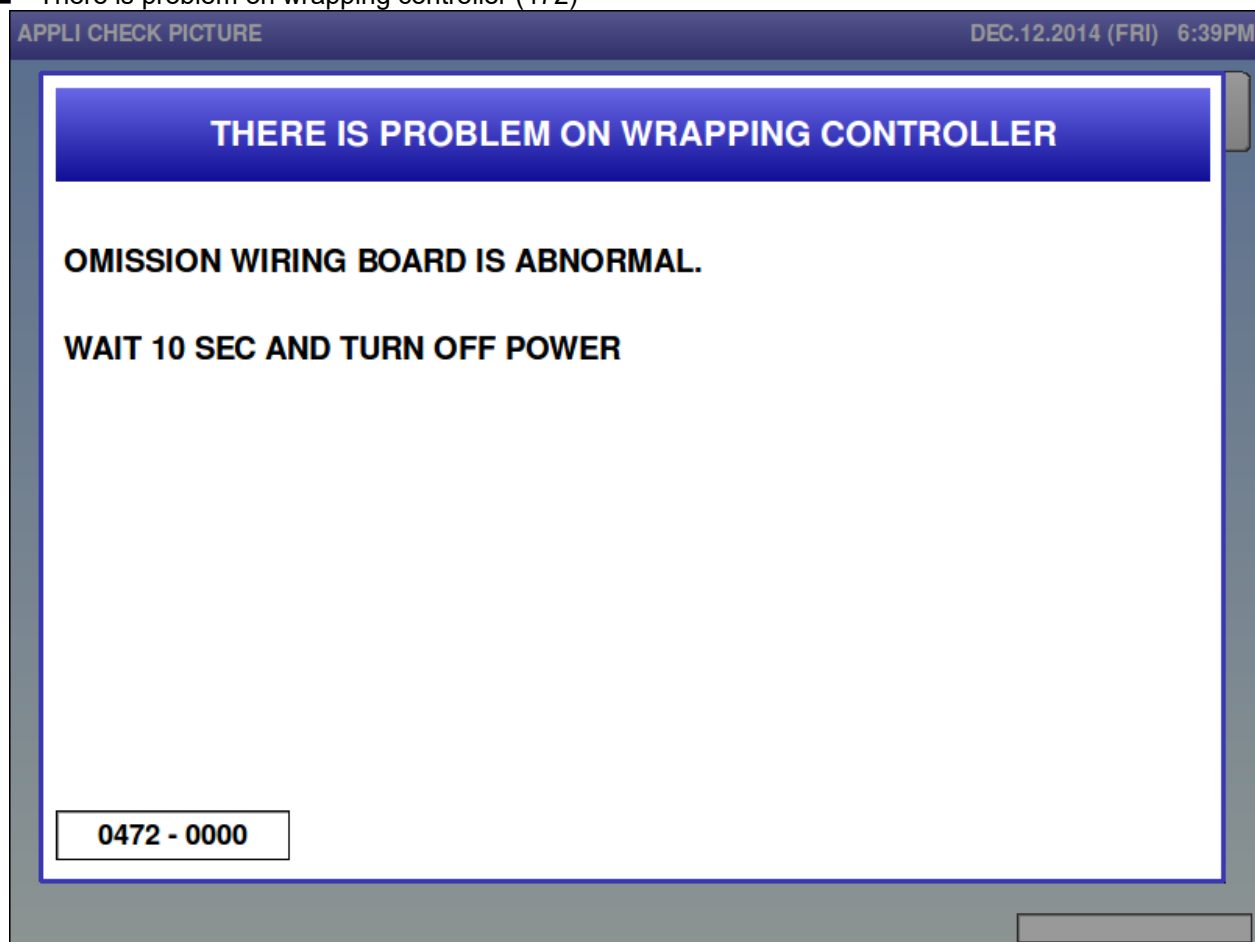

Error content	Wrapper wiring board error.
Detail	A communication error occurred between parent (wrapper control board: P-1105: A200) and child (P-1105: A100, A300). Sub-error meanings are as follows: 0000: A communication error between P-1105 [A100] and P-1105 [A300]. 0001: A communication error with P-1105 [A300]. 0002: A communication error with P-1105 [A100].
Solution	Restore power
Action by user	
Action by service representative	
Related part	<ul style="list-style-type: none"> ① P-1105 [A100], [A200], [A300] ② 23-pin and 24-pin in XJ7 of P1105 [A100] must be short-circuited. ③ 21-pin and 22-pin in XJ7 of P1105 [A200] must be short-circuited. ④ 21-pin and 22-pin, and 23-pin and 24-pin in XJ7 of P1105 [A100] must be short-circuited.
Remarks	

■ There is problem on seal heater (473)

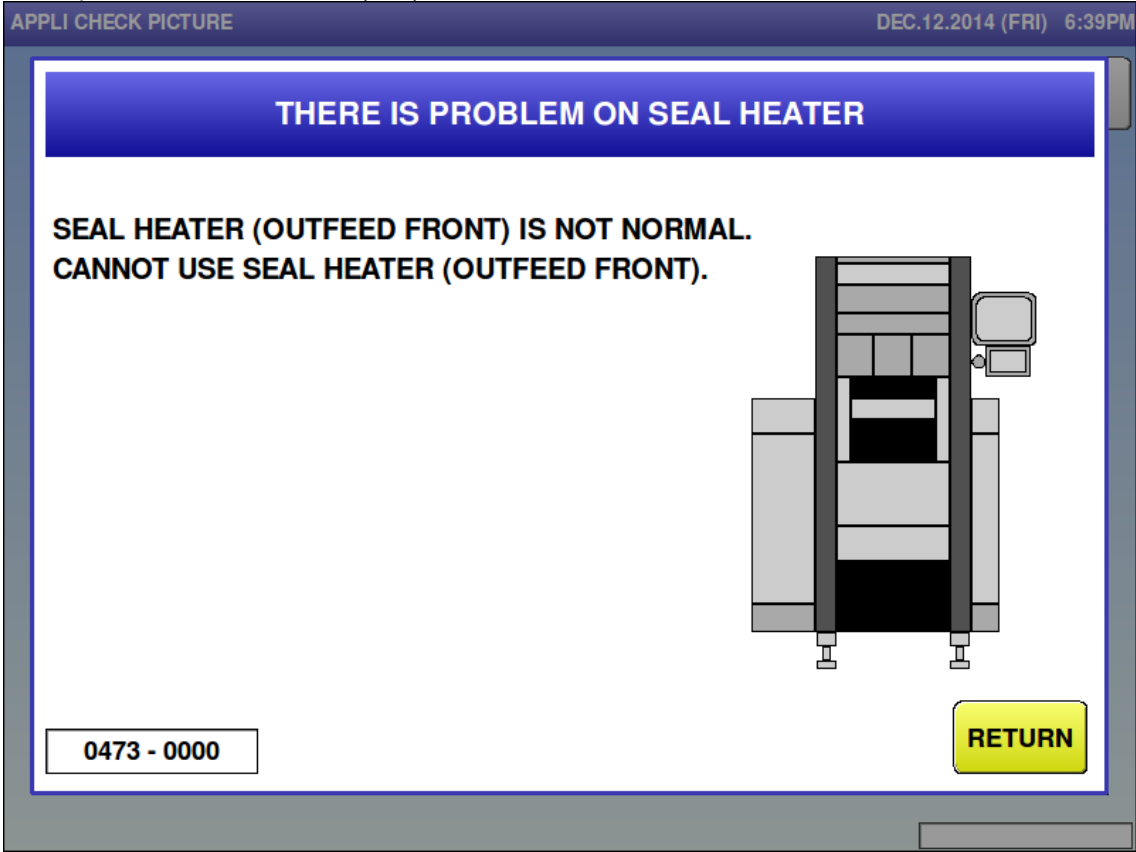

Error content	Front outfeed heater error.
Detail	An error occurred in either the front heater or the thermostat monitoring the front heater temperature. Sub-error meanings are as follows: 0000: The heater temperature does not rise while heating (Thermostat value does not change). 0001: Thermostat error (Disconnection or short circuit).
Solution	[RETURN] button
Action by user	
Action by service representative	
Related part	① P-1105 [A200] ② Outfeed front heater [E70]. ③ Fuse for outfeed heater [F106, F107]. ④ Thermistor for outfeed front heater [R1]. ⑤ SSR for outfeed front heater [K200].
Remarks	The heater is switched OFF when this error occurs.

- There is problem on seal heater (474)

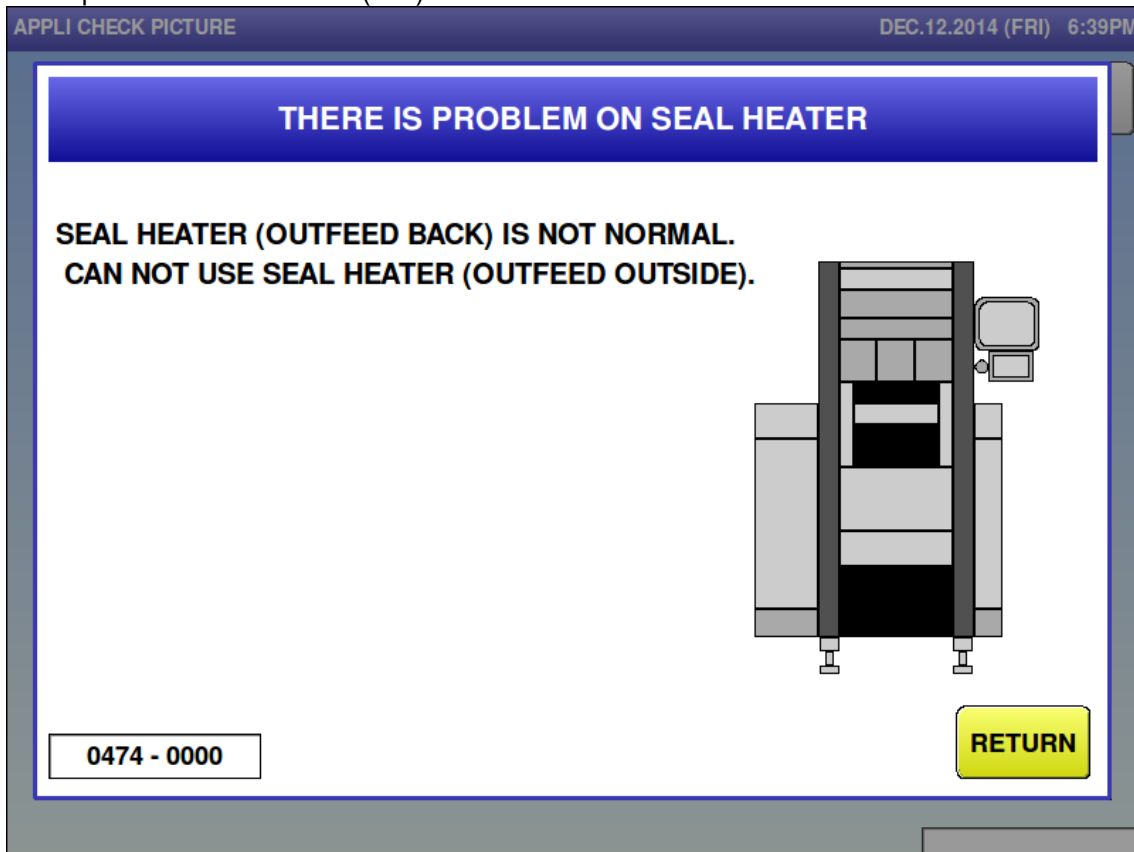

Error content	Back outfeed heater error.
Detail	An error occurred in either the rear heater or the thermostat monitoring the rear heater temperature. Sub-error meanings are as follows: 0000: The heater temperature does not rise while heating (Thermostat value does not change). 0001: Thermostat error (Disconnection or short circuit).
Solution	[RETURN] button
Action by user	
Action by service representative	
Related part	① P-1105 [A200] ② Outfeed front heater [E71]. ③ Fuse for outfeed heater [F106, F107]. ④ Thermistor for outfeed front heater [R2]. ⑤ SSR for outfeed front heater [K201].
Remarks	The heater is switched OFF when this error occurs.

■ Wrong selection for big/small lift (475)

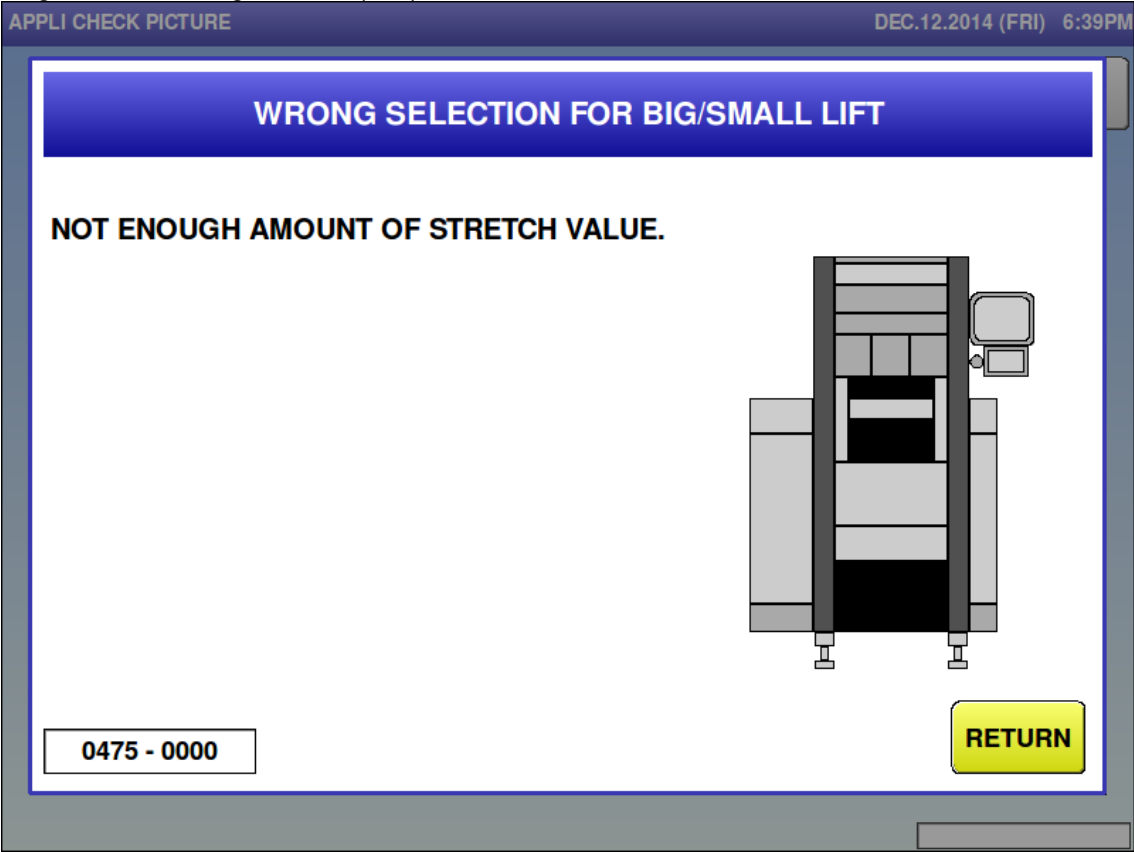

Error content	Wrong selection for big/small lift.
Detail	The rear feeder is in a position where it may come in contact with the lift when it is pushed up. Sub-error meanings are as follows: 0000 or 001*: Error occurs when small lift is selected (Not enough stretch). 0001 or 002*: Error occurs when large lift is selected (Lift selection is unsuitable or not enough stretch). * either 0,1, or 2
Solution	[RETURN] button
Action by user	
Action by service representative	
Related part	
Remarks	Set the appropriate values for the lift selection and the stretch (fine adjustment) after cancelling the error.

■ Wrong tray against programmed tray (476)

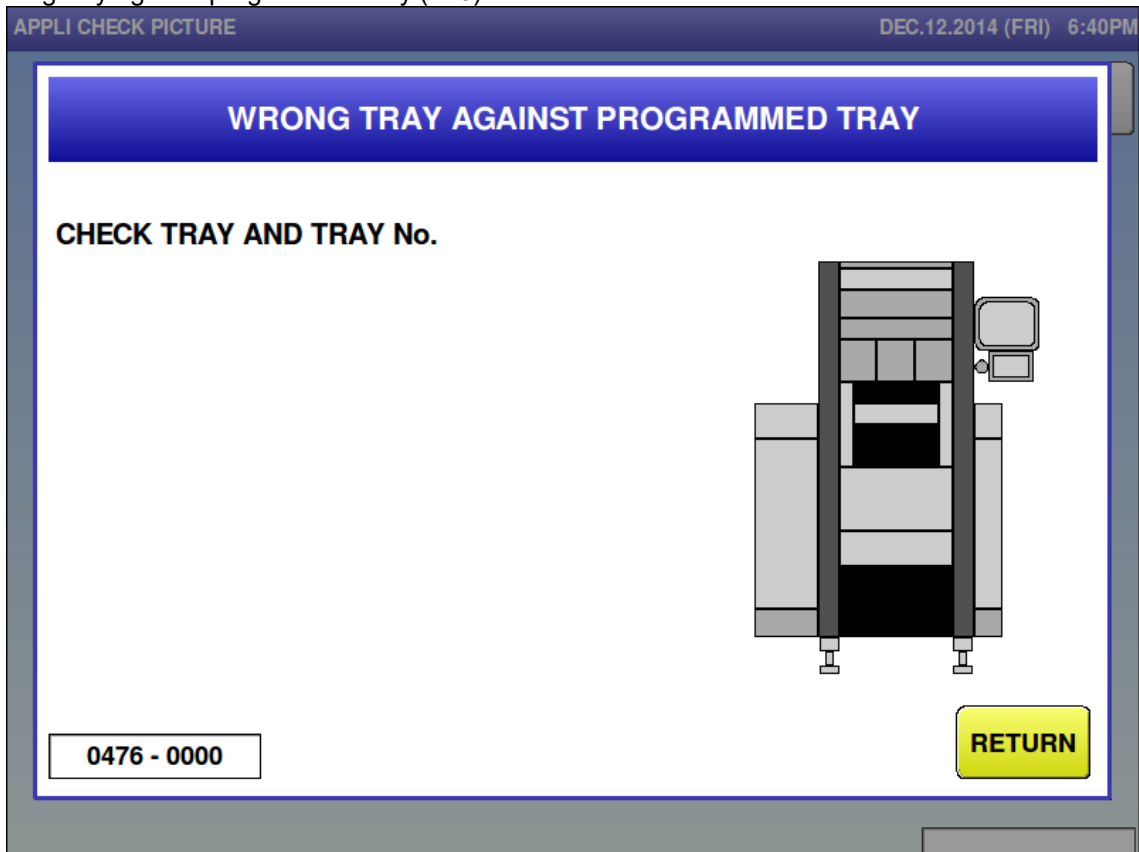

Error content	Tray settings and feed tray are different.
Detail	The wrapper detected the narrow-side dimensions of the feed tray are more than 50 mm larger than the selected tray. The narrow-side dimensions detected by the wrapper are shown in the sub-error.
Solution	[RETURN] button
Action by user	Clean up the sensor that detects products on the lift.
Action by service representative	Adjust the sensitivity of the sensor that detects products on the lift.
Related part	① P-1105 [A200] ② Detection of products on the lift [B206]. ③ Feeder motor
Remarks	See error 486 Product Is On The Lift for sensor calibration instructions.

■ Feeder bar is not original position (477)

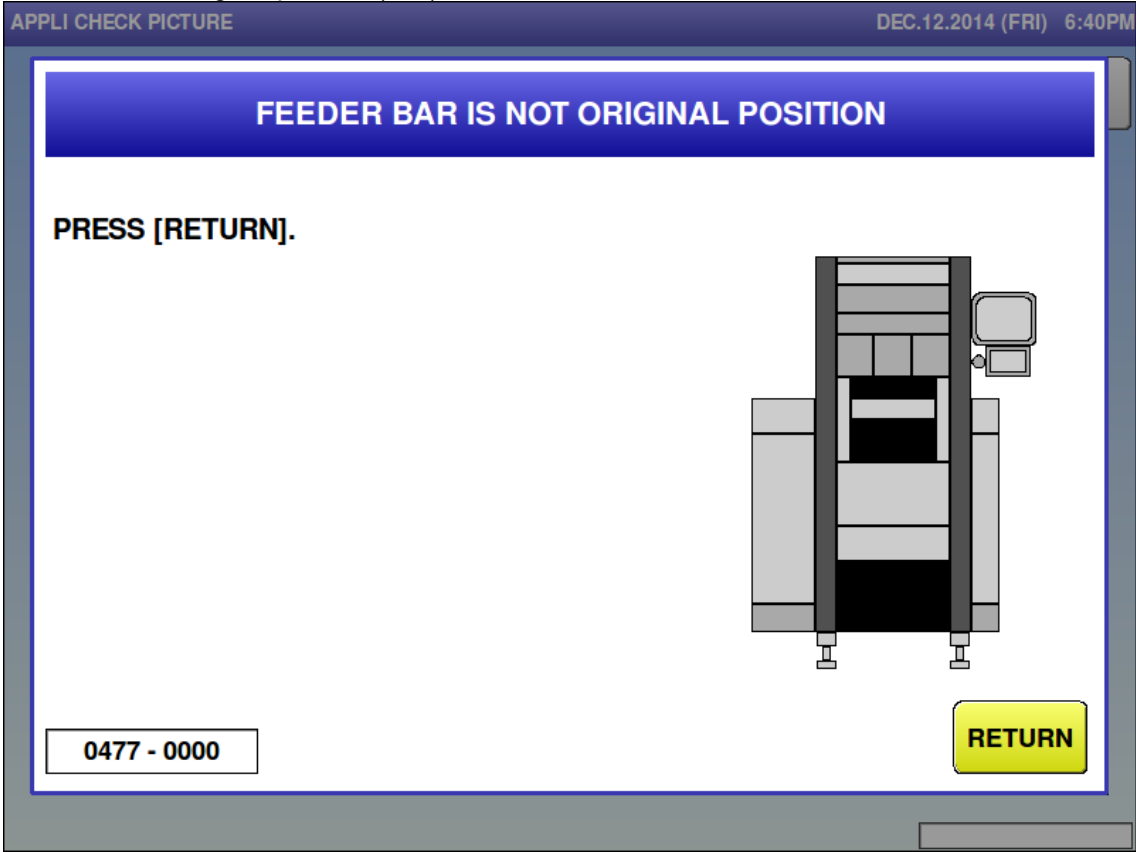

Error content	Feeder bar is not original position.
Detail	The feeder bar was not in its original position when the wrapper started feeder operations (excluding return operation).
Solution	[RETURN] button
Action by user	
Action by service representative	
Related part	① P-1105 [A200] ② Origin point of feeder bar [B204].
Remarks	

■ Insert plate is not set for the upper (478)

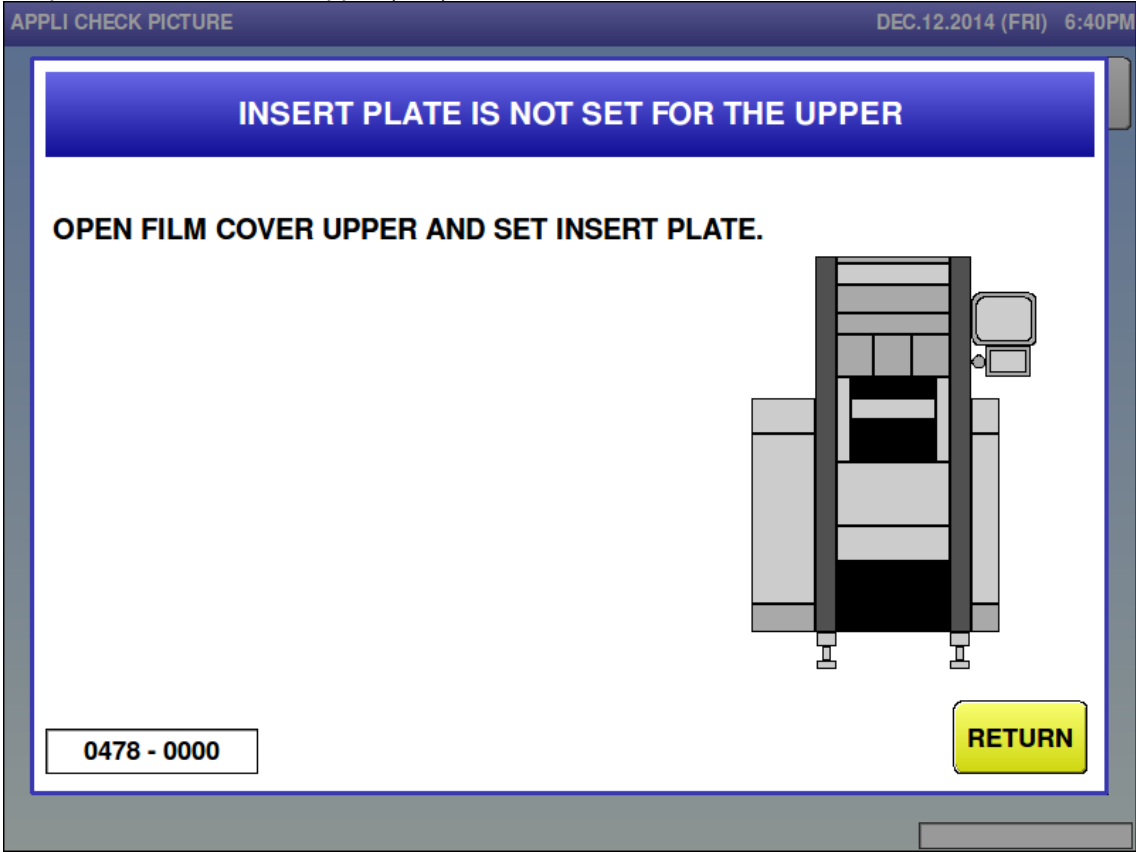

Error content	Insert plate is not set for the upper.
Detail	Film exchange cover is closed, but upper film insert open/close is open.
Solution	Press the [RETURN] button after setting the insert plate.
Action by user	
Action by service representative	
Related part	<If the error persists even after the insert open/close is closed> ① P-1105 [A300] ② Upper film inserts open/close [B307].
Remarks	

■ Insert plate is not set for the lower (479)

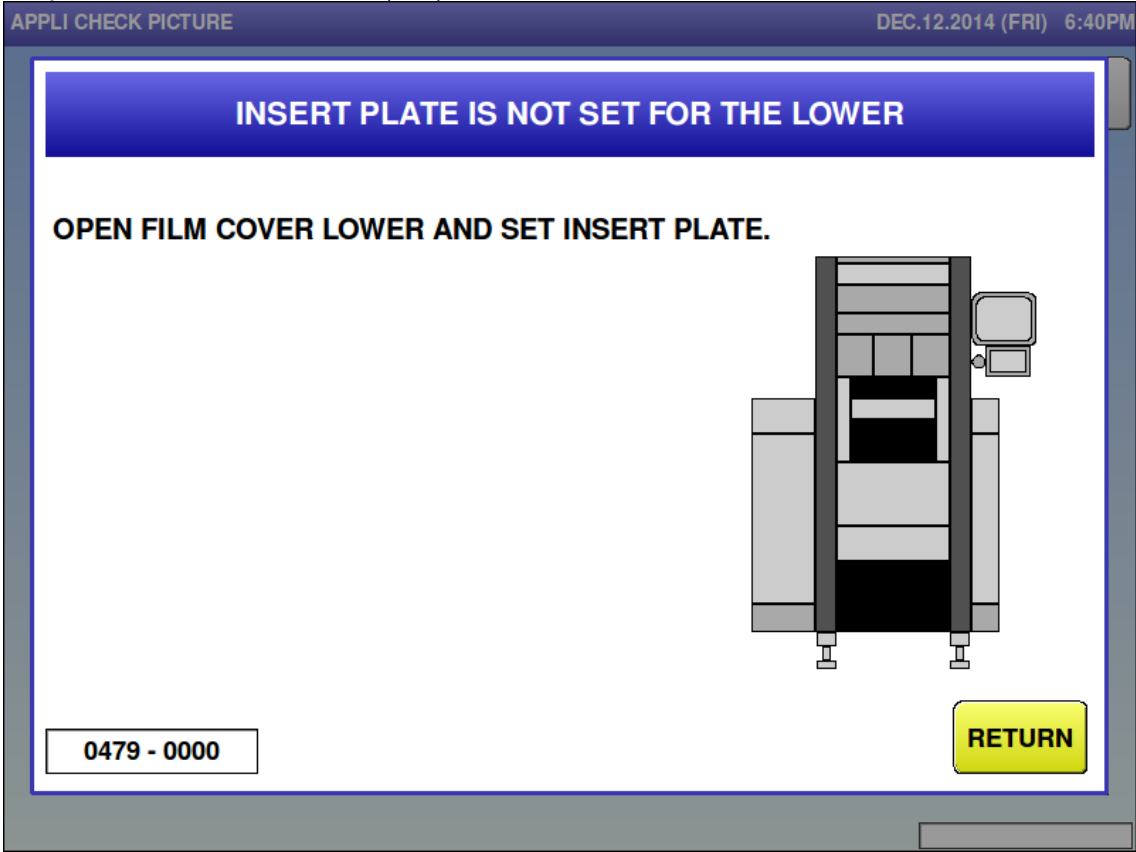

Error content	Insert plate is not set for the lower.
Detail	Film exchange cover is closed, but lower film insert open/close is open.
Solution	Press the [RETURN] button after setting the insert plate.
Action by user	
Action by service representative	
Related part	<If the error occurs even after the insert open/close is closed> ① P-1105 [A300] ② Lower film inserts open/close [B305]
Remarks	

■ Film is remaining (480-0001)

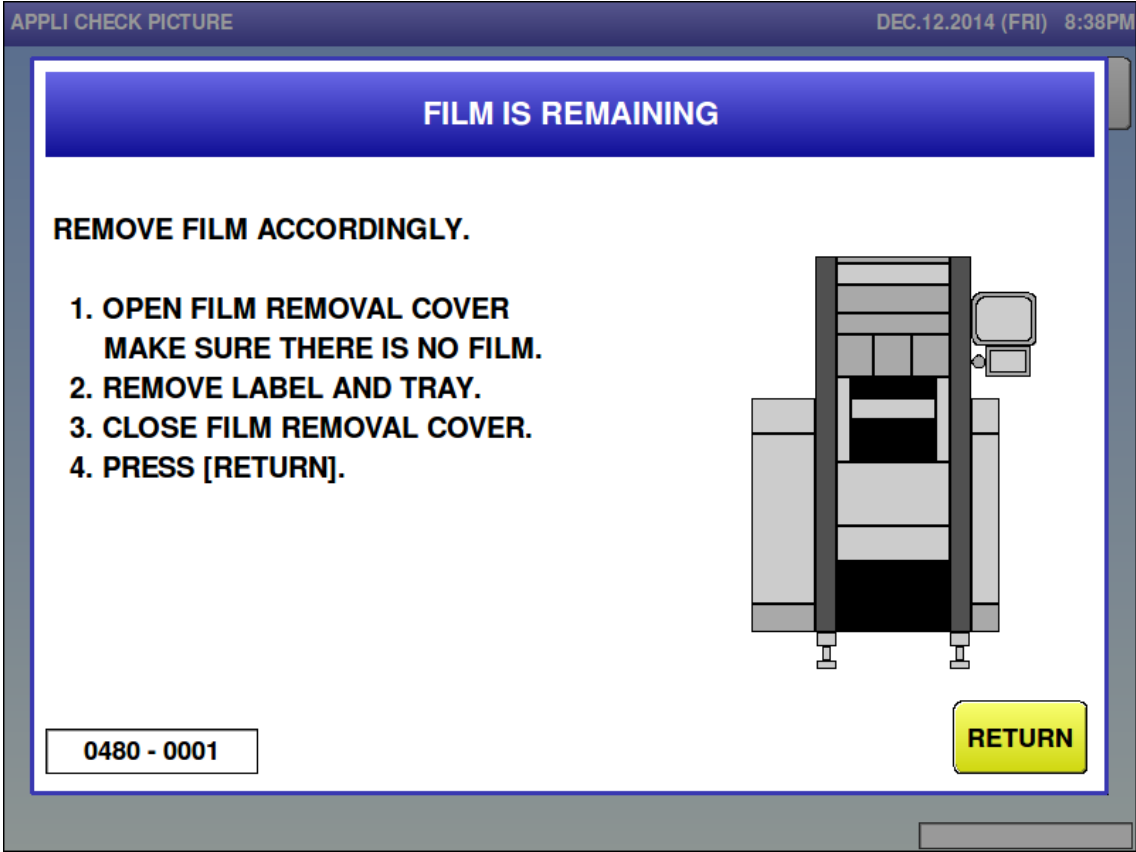

Error content	Film is remaining.
Detail	The film sensor board is knocked over when the film started to be sent. The bit mask shows the knocked over sensor location. Number and location correlation are as follows: 0001: Rear right 0010: Front right 0100: Rear left 1000: Front left (Ex) If remaining film were detected in the rear right and front right, the sub-error would be 0011.
Solution	Press the [RETURN] button after removing film.
Action by user	
Action by service representative	
Related part	<If the error occurs even after the film is removed> ① P-1105 [A200] ② Film presence front right [B209]. ③ Film presence front left [B208]. ④ Film presence rear left [B210]. ⑤ Film presence rear right [B209].
Remarks	

■ Film is remaining (480—0100)

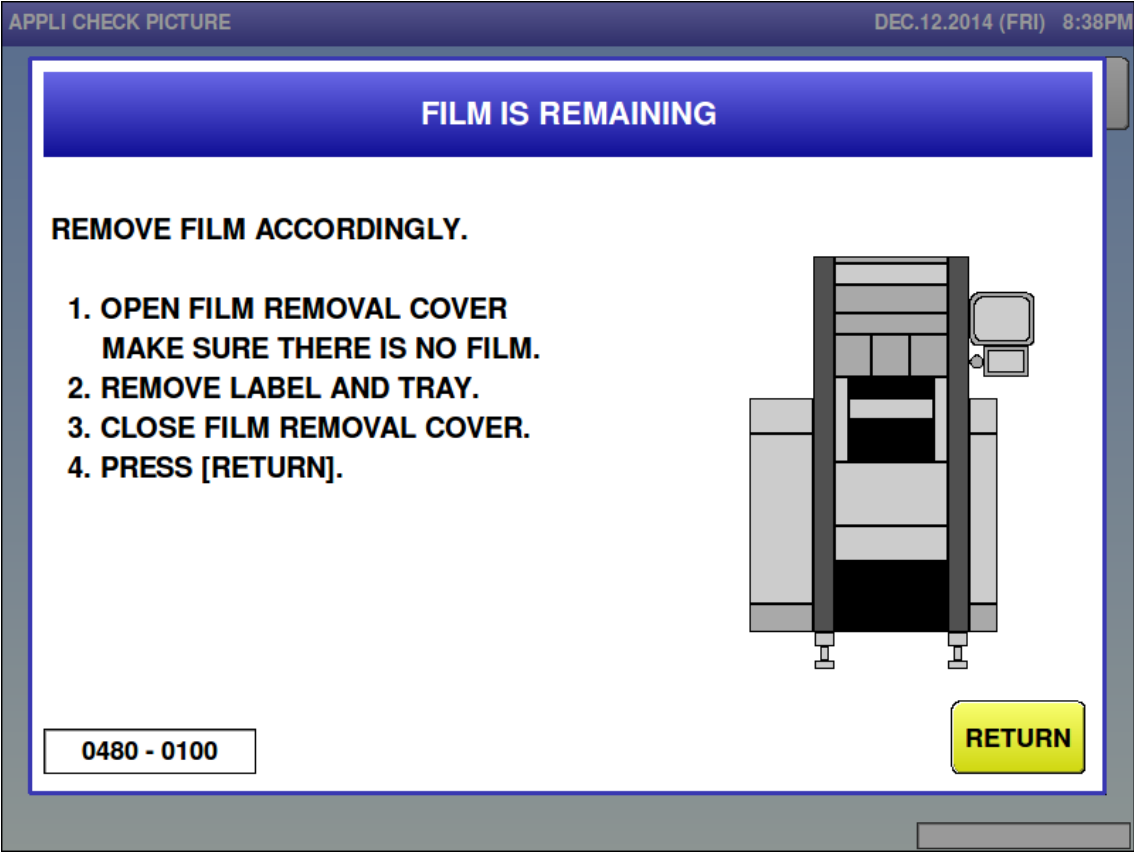

Error content	Film is remaining.
Detail	<p>The film sensor board is knocked over when the film started to be sent.</p> <p>The bit mask shows the knocked over sensor location. Number and location correlation are as follows:</p> <p>0001: Rear right 0010: Front right 0100: Rear left 1000: Front left</p> <p>(Ex) If remaining film were detected in the rear right and front right, the sub-error would be 0011.</p>
Solution	Press the [RETURN] button after removing film.
Action by user	
Action by service representative	
Related part	<p><If the error occurs even after the film is removed></p> <p>① P-1105 [A200] ② Film presence front right [B209]. ③ Film presence front left [B208]. ④ Film presence rear left [B210]. ⑤ Film presence rear right [B211].</p>
Remarks	

■ Film is remaining (480-0101)

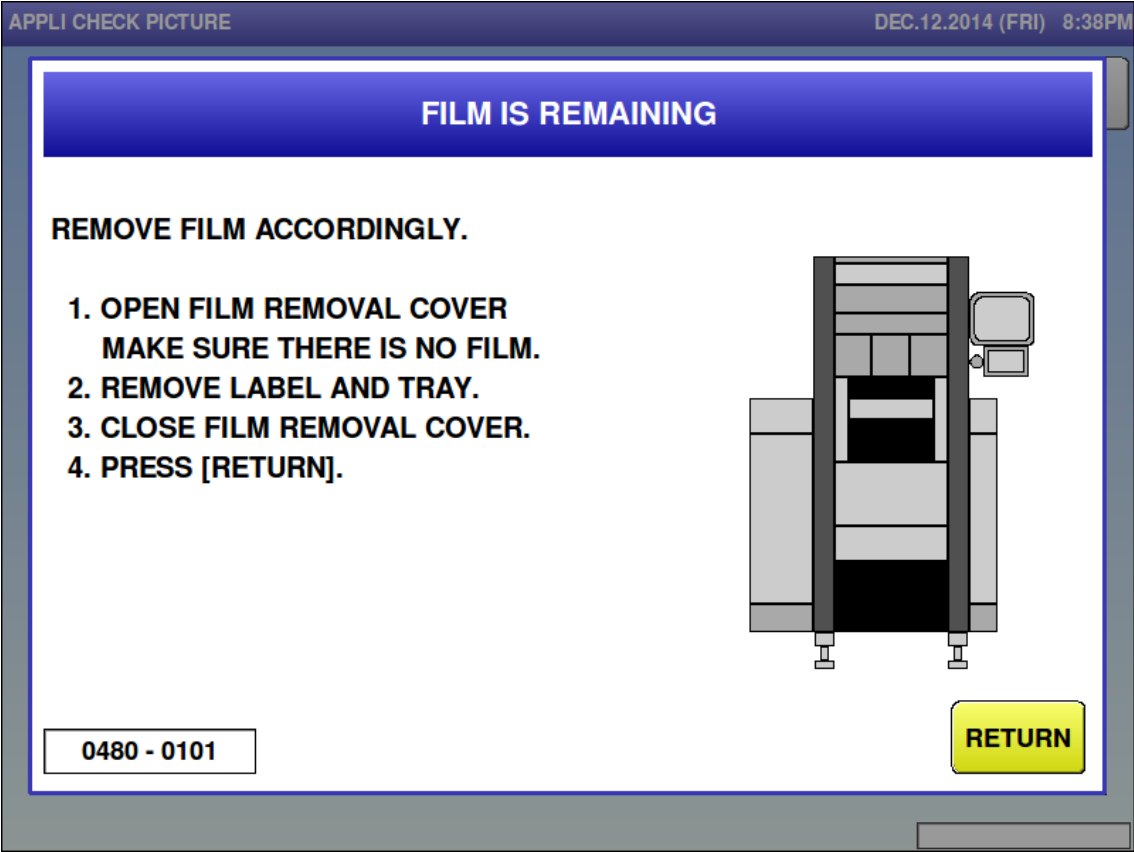

Error content	Film is remaining.
Detail	<p>The film sensor board is knocked over when the film started to be sent.</p> <p>The bit mask shows the knocked over sensor location. Number and location correlation are as follows:</p> <p>0001: Rear right 0010: Front right 0100: Rear left 1000: Front left</p> <p>(Ex) If remaining film were detected in the rear right and front right, the sub-error would be 0011.</p>
Solution	Press the [RETURN] button after removing film.
Action by user	
Action by service representative	
Related part	<p><If the error occurs even after the film is removed></p> <p>① P-1105 [A200] ② Film presence front right [B209]. ③ Film presence front left [B208]. ④ Film presence rear left [B210]. ⑤ Film presence rear right [B211].</p>
Remarks	

■ Cutter is not back to original position (481)

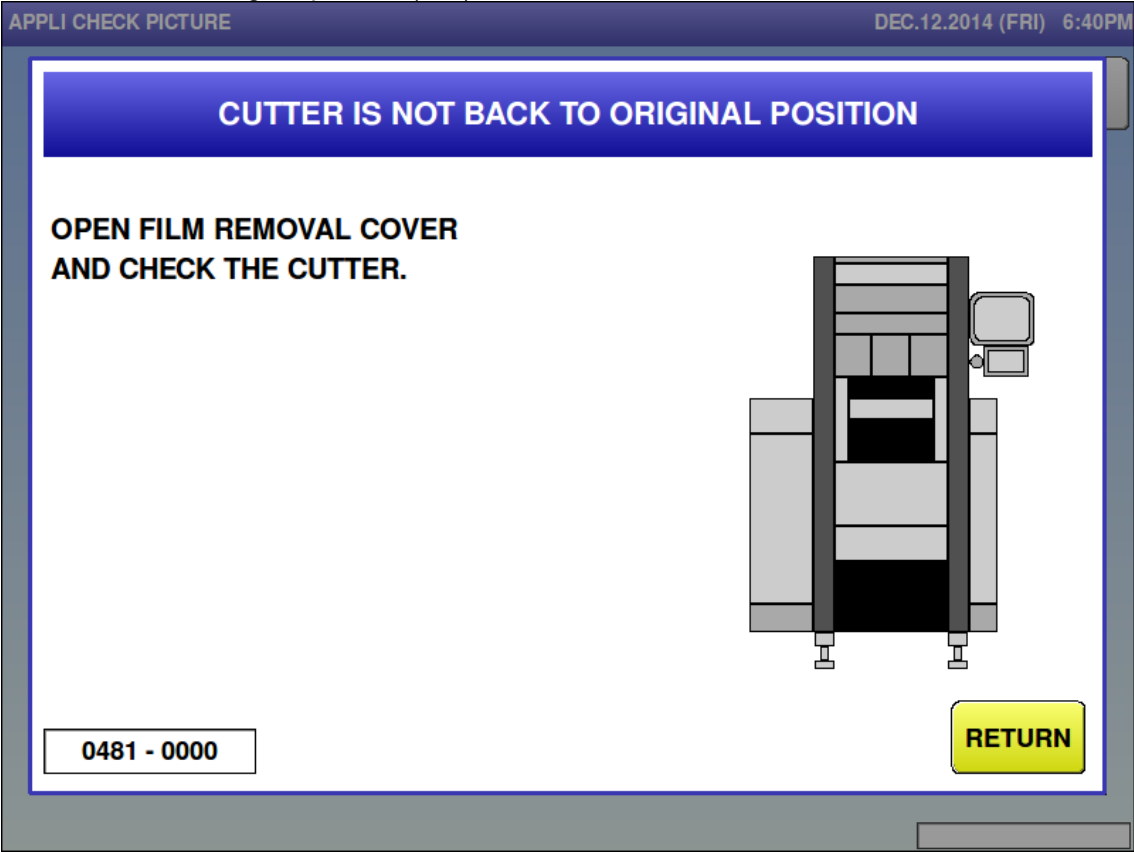

Error content	Cutter is not back to original position.
Detail	Cutter is not back to original position when starting cutter operation.
Solution	Press the [RETURN] button after checking for objects.
Action by user	
Action by service representative	
Related part	<ul style="list-style-type: none"> ① P-1105 [A300] ② Origin point of cutter [B300]. ③ Cutter solenoid front [L300]. ④ Cutter solenoid rear [L301].
Remarks	

■ Insert plate is not back to original position (482)

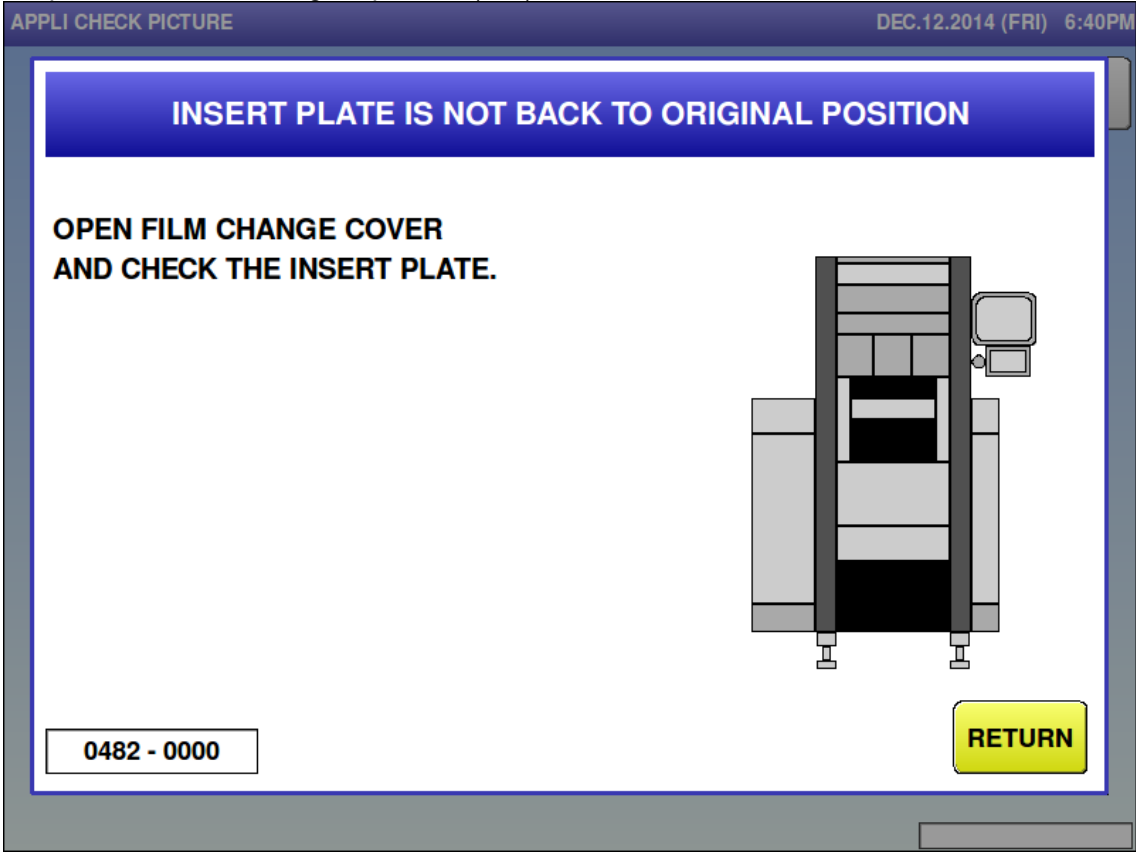

Error content	Insert plate is not back to original position.
Detail	<p>The cutter can't be switched on as the insert plate has not returned to its original position when cutter operation started.</p> <p>Sub-error meanings are as follows:</p> <p>0000: Upper side insert plate did not return to its original position.</p> <p>0001: Lower side insert plate did not return to its original position.</p> <p>0006: Insert plate of send side did not return to its original position during returning operation.</p> <p>0007: Insert plate did not return to its original position while loading.</p>
Solution	Press the [RETURN] button after checking the insert plate.
Action by user	
Action by service representative	
Related part	<p>① P-1105 [A300]</p> <p>② Origin point of insert [B301].</p>
Remarks	

■ Sensor for the back side of feeder is abnormal (483)

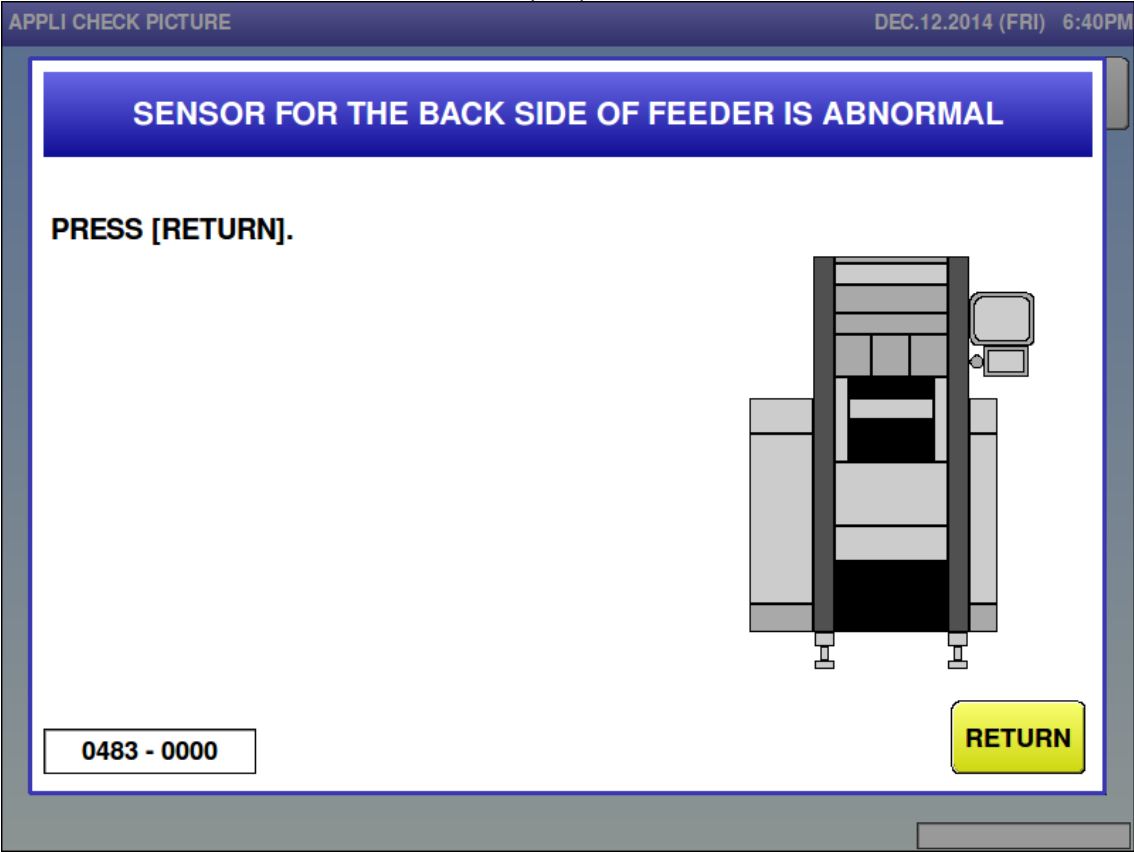

Error content	Sensor for the back side of feeder is abnormal.
Detail	<p>An impossible input combination has occurred in the sensor (Original point, small lift boundary, large lift boundary) detecting the back feeder position. The sub-error screens the input conditions as shown below.</p> <p>0003: Original point and the small lift boundary sensor are not receiving light.</p> <p>0005: The small lift boundary sensor and the large lift boundary sensor are not receiving light.</p> <p>0006: The original point sensor and the large lift boundary sensor are not receiving light.</p> <p>0007: Three of them are not receiving light.</p>
Solution	[RETURN] button
Action by user	
Action by service representative	
Related part	<p>① P-1105 [A200]</p> <p>② Back side of feeder, origin point [B212].</p> <p>③ Back side of feeder, position small [B217].</p> <p>④ Back side of feeder, position large [B218].</p>
Remarks	

■ Heater safety guard is up (484)

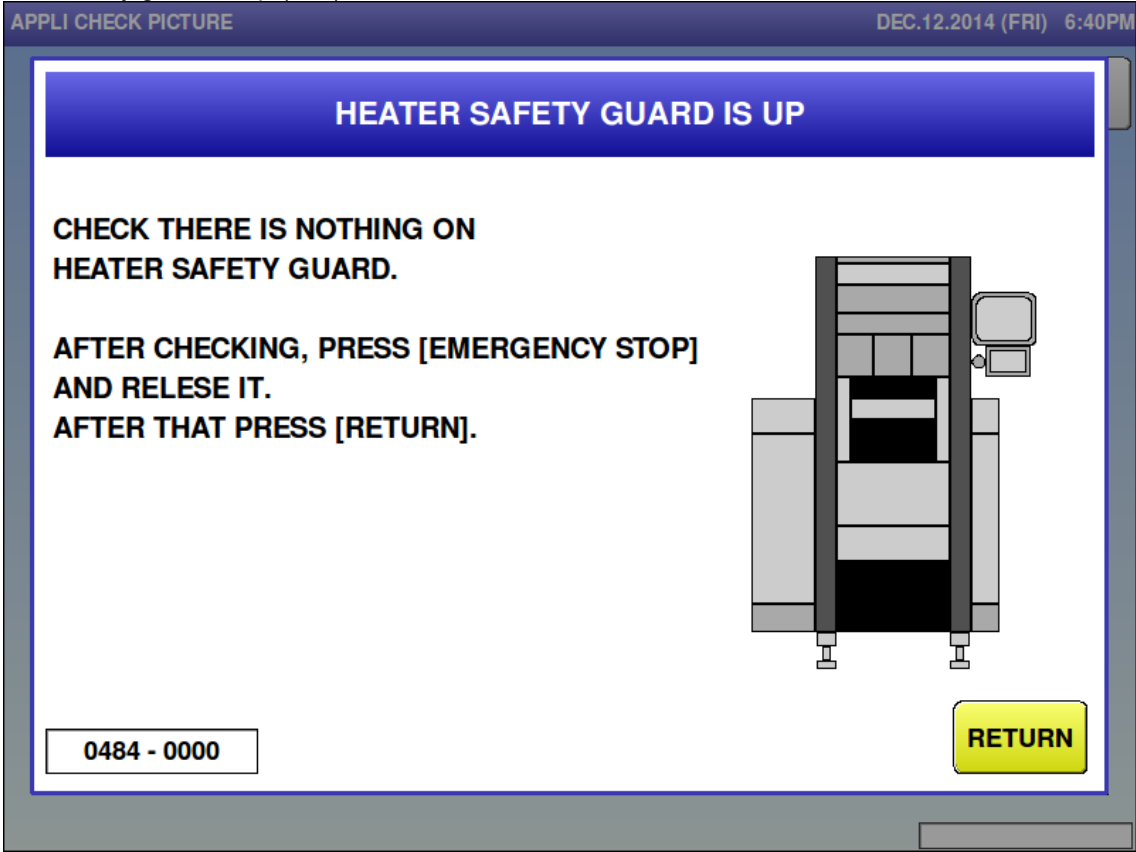

Error content	Heater safety guard is up.
Detail	After the pusher is restored, if the heater safety guard is up, the pusher downs the guard. If the sensor is still emitted afterwards, an error occurs.
Solution	[RETURN] button
Action by user	
Action by service representative	
Related part	<ul style="list-style-type: none"> ① P-1105 [A100] ② Origin point of heater safety guard [B103]. ③ Heater safety guard solenoid [L100].
Remarks	

■ Auxiliary for magnetic contact is abnormal (485)

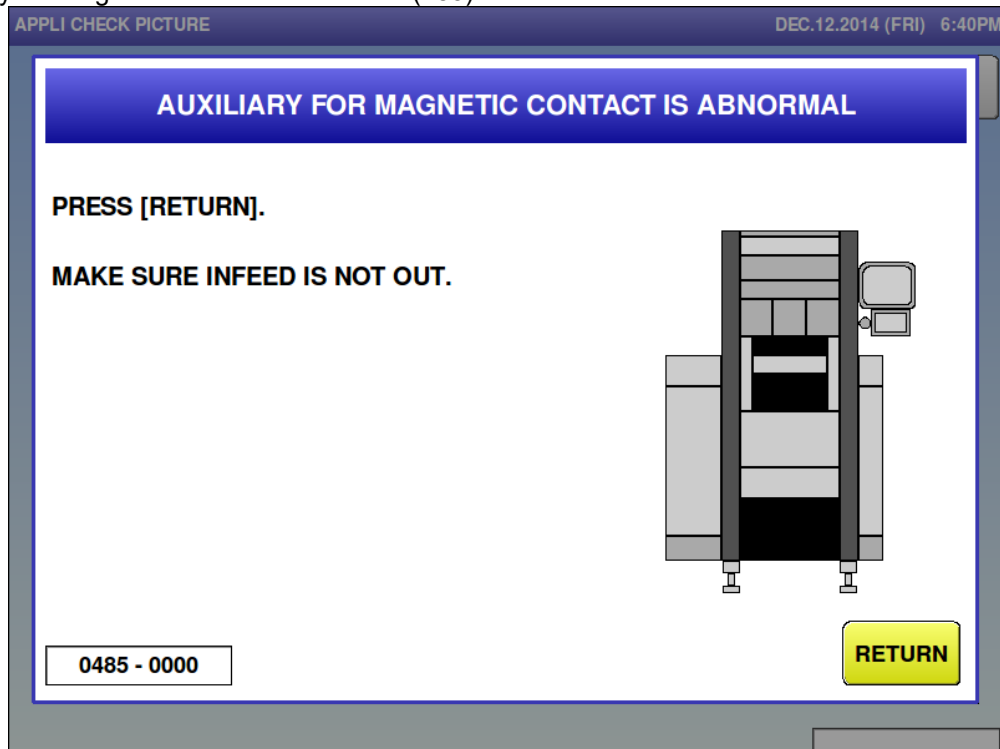

Error content	Auxiliary for magnetic contact is abnormal
Detail	<p>Error occurred between the electromagnetic contact auxiliary contact input opening and closing the power line and each cover switch open/closed condition while waiting for the wrapper or during operation. This electromagnetic switch is blocking the power line (200VAC, 24VDC).</p> <p>For example, if the electromagnetic switch auxiliary contact is open and each cover safety switch and the emergency stop switch are closed and this error continues for 5 seconds, this error occurs.</p> <p>The switch location where the error occurred is displayed in the sub-error as below.</p> <p>If multiple covers are open, values given below are added and displayed in the sub-error.</p> <p>2048: Film replacement cover open.</p> <p>1024: Front cover is open.</p> <p>0256: Infeed conveyors pulled out.</p> <p>0128: Emergency stop switch ON.</p> <p>0064: Film removal cover is open.</p> <p>0000: No cover is open.</p>
Solution	[RETURN] button
Action by user	
Action by service representative	
Related part	<p>[485-0000]</p> <p>① P-1105 [A100-XJ19]</p> <p>② Magnetic contact [K100, K101] and wiring of magnetic contact.</p> <p>[Other than 485-0000]</p> <p>① Wiring to the switch described in the detail.</p>
Remarks	It is not an actual failure; however, this error occurs easily when a cover is half-way closed.

■ Product is on the lift (486)

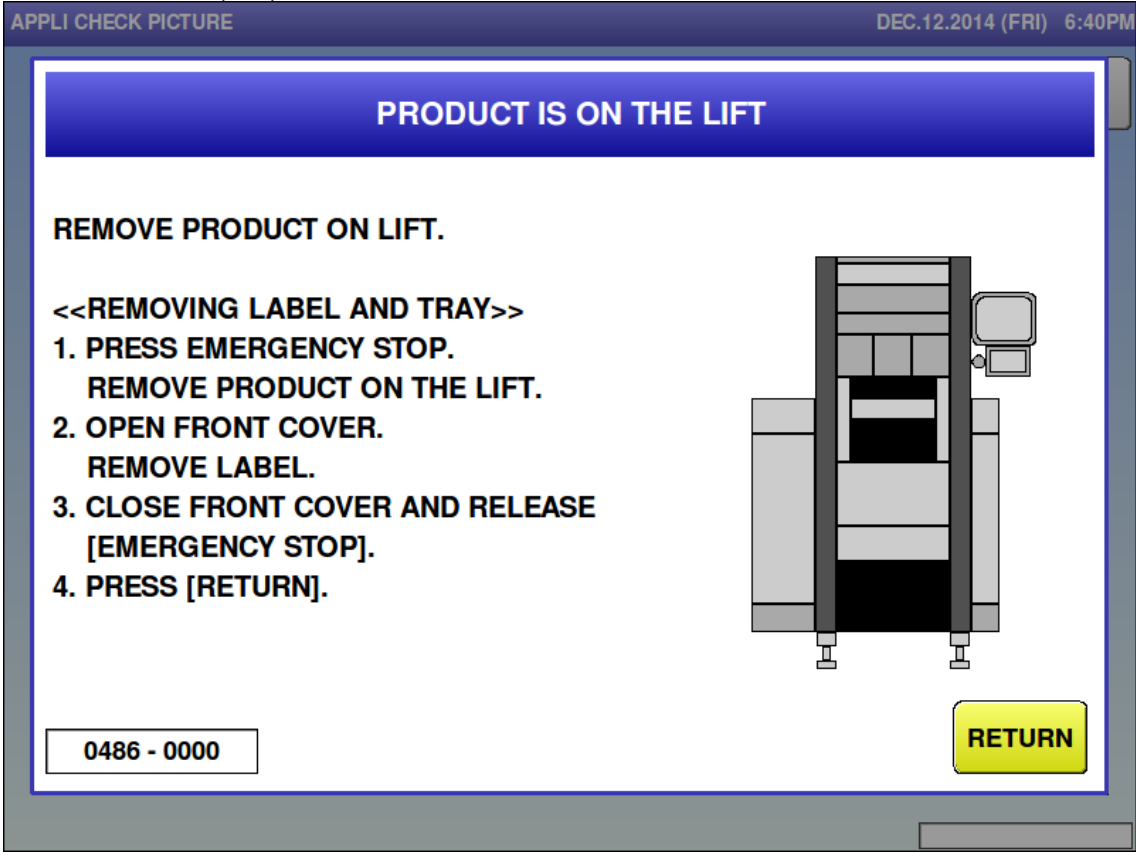

Error content	Product is on the lift
Detail	<p>There was a product on the lift when each of the following operations was started (completed).</p> <p>Sub-error meanings are as follows:</p> <p>0000: After completion of returning operation</p> <p>0004: Wrapping the first product is attempted.</p> <p>0007: Shifting to sleep mode</p> <p>Others: Sending film or film loading is attempted</p>
Solution	Press the [RETURN] button after removing the product
Action by user	
Action by service representative	<ol style="list-style-type: none"> 1. Clean the "Product on Lift" sensor and reflector. 2. Verify the Lift does block the "Product on Lift" sensor, adjust height as needed. 3. Calibrate the "Product on Lift" sensor*.
Related part	<ol style="list-style-type: none"> ① P-1105 [A200] ② Detection of products on the lift [B206]
Remarks	
*Sensor calibration:	<ol style="list-style-type: none"> 1. Place the lowest height tray (or a transparent tray if used in the wrapper) on the lift. <ol style="list-style-type: none"> a. Turn the sensitivity potentiometer all the way to the Minimum. b. Adjust the sensitivity little by little until the red LED turns on – this is position "A". c. If the LED does not turn on after turning all the way to Maximum then the Maximum end point will be the position "A". 2. Remove the tray and turn the sensitivity all the way to the Maximum. <ol style="list-style-type: none"> a. Adjust the sensitivity little by little until the red LED turns off – this is position "B". b. If the LED does not turn off after turning all the way to Minimum then the Minimum end point will be the position "B". 3. Adjust the sensitivity to the middle position between point "A" and point "B".

■ Film loading for the upper (490—0000)

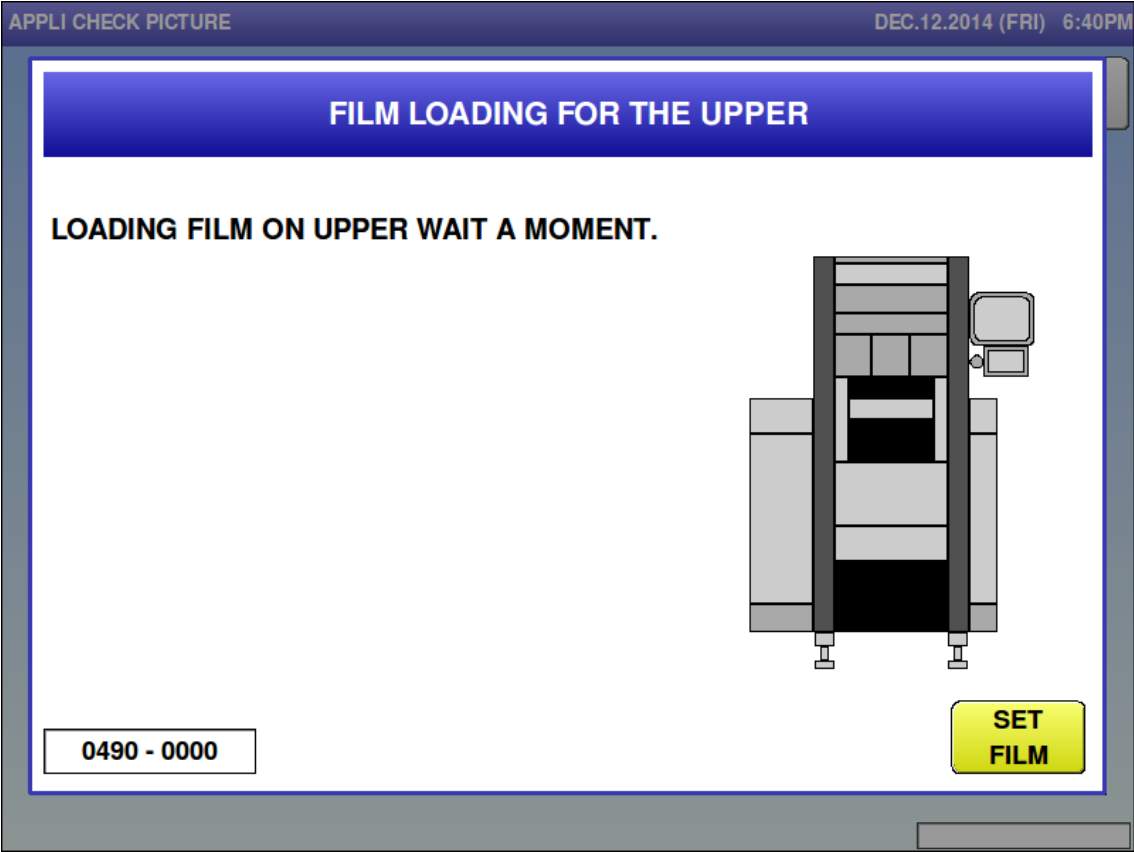

Error content	Starting the upper film loading.
Detail	Film loading operation began after film loading procedure completion. Film loading operation began after pressing the film set button.
Solution	Ends automatically after film loading has completed.
Action by user	
Action by service representative	
Related part	
Remarks	

■ Film loading for the lower (490–0001)

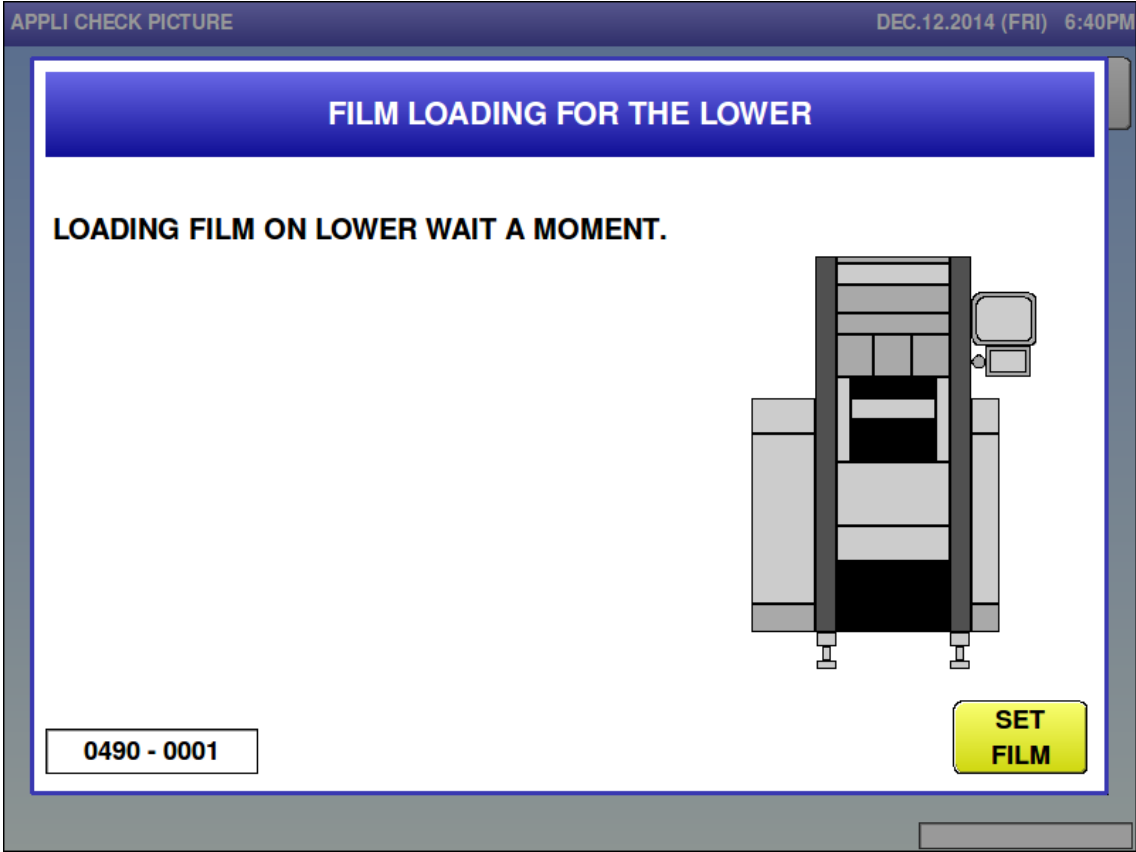

Error content	Starting the lower film loading.
Detail	Film loading operation began after film loading procedure completion. Film loading operation began after pressing the film set button.
Solution	Ends automatically after film loading has completed.
Action by user	
Action by service representative	
Related part	
Remarks	

- Film loading for the upper is completed (491—0000)

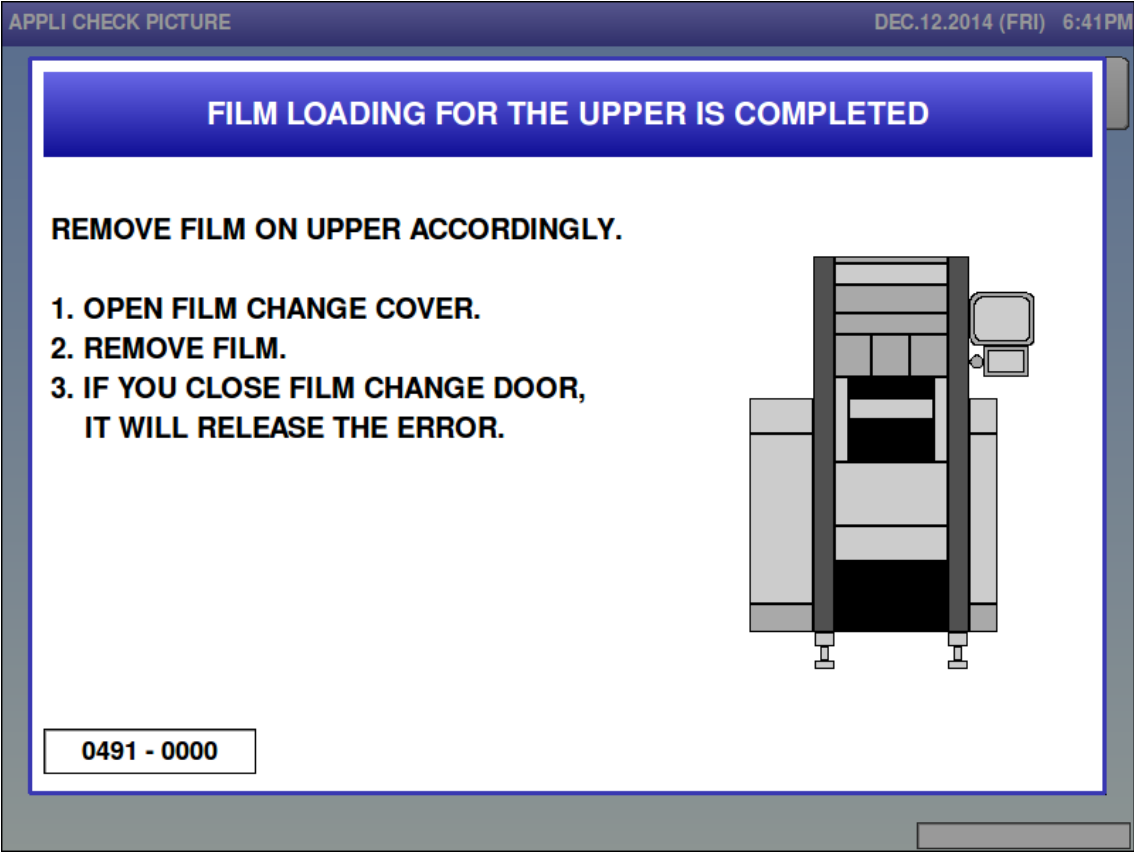

Error content	Film loading for the upper is completed.
Detail	Film loading is completed.
Solution	Open the film remove cover, remove film, and close the door.
Action by user	
Action by service representative	
Related part	
Remarks	

- Film loading for the lower is completed (491-0001)

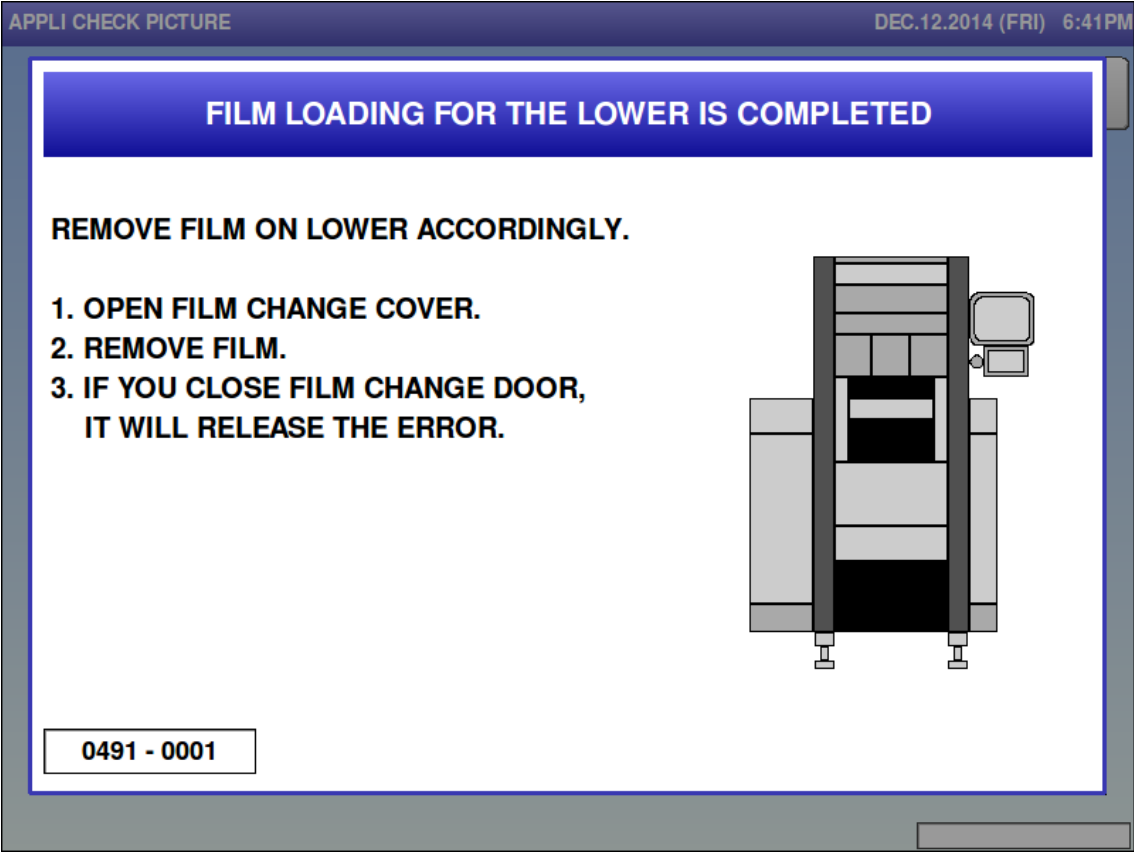

Error content	Film loading for the lower is completed.
Detail	Film loading is completed.
Solution	Open the film remove cover, remove film, and close the door.
Action by user	
Action by service representative	
Related part	
Remarks	

■ Film removal is completed (492—0001)

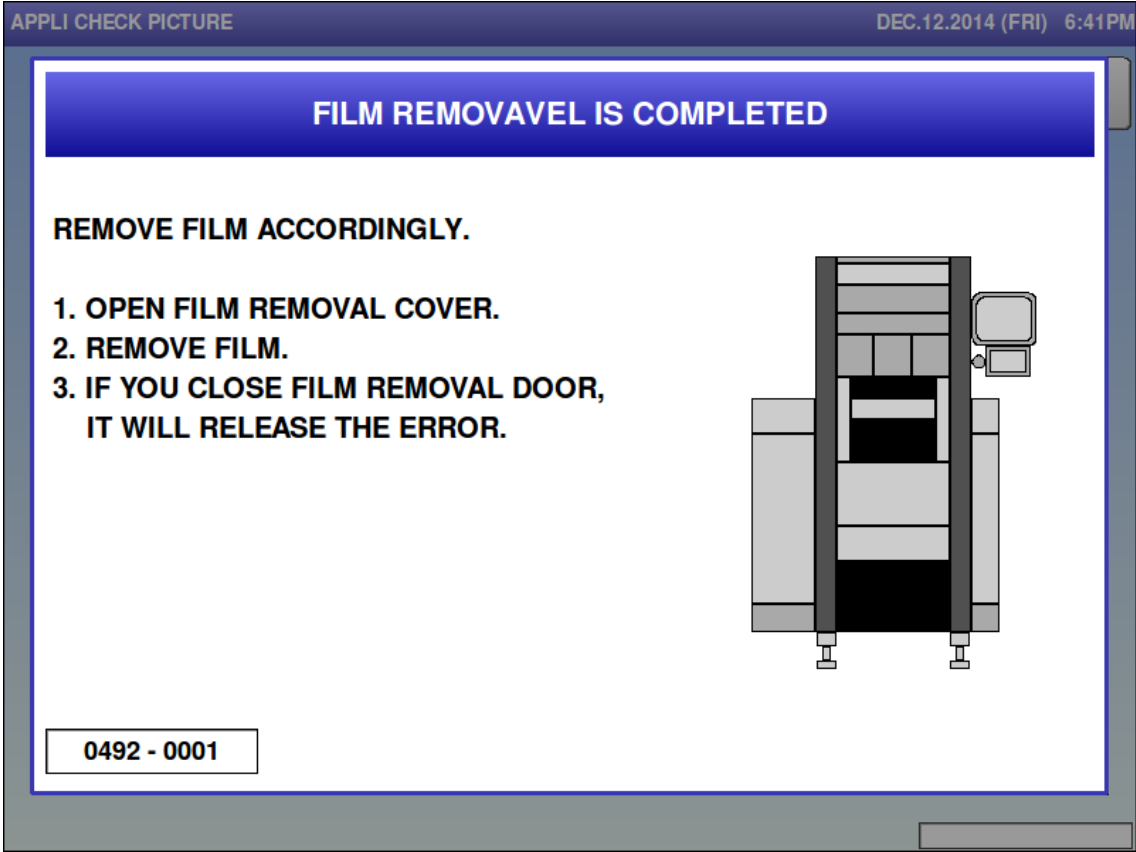

Error content	Film removal is completed.
Detail	Film removal is completed.
Solution	Open the film remove cover, remove film, and close the door.
Action by user	
Action by service representative	
Related part	
Remarks	

■ Film removal is completed (492—0002)

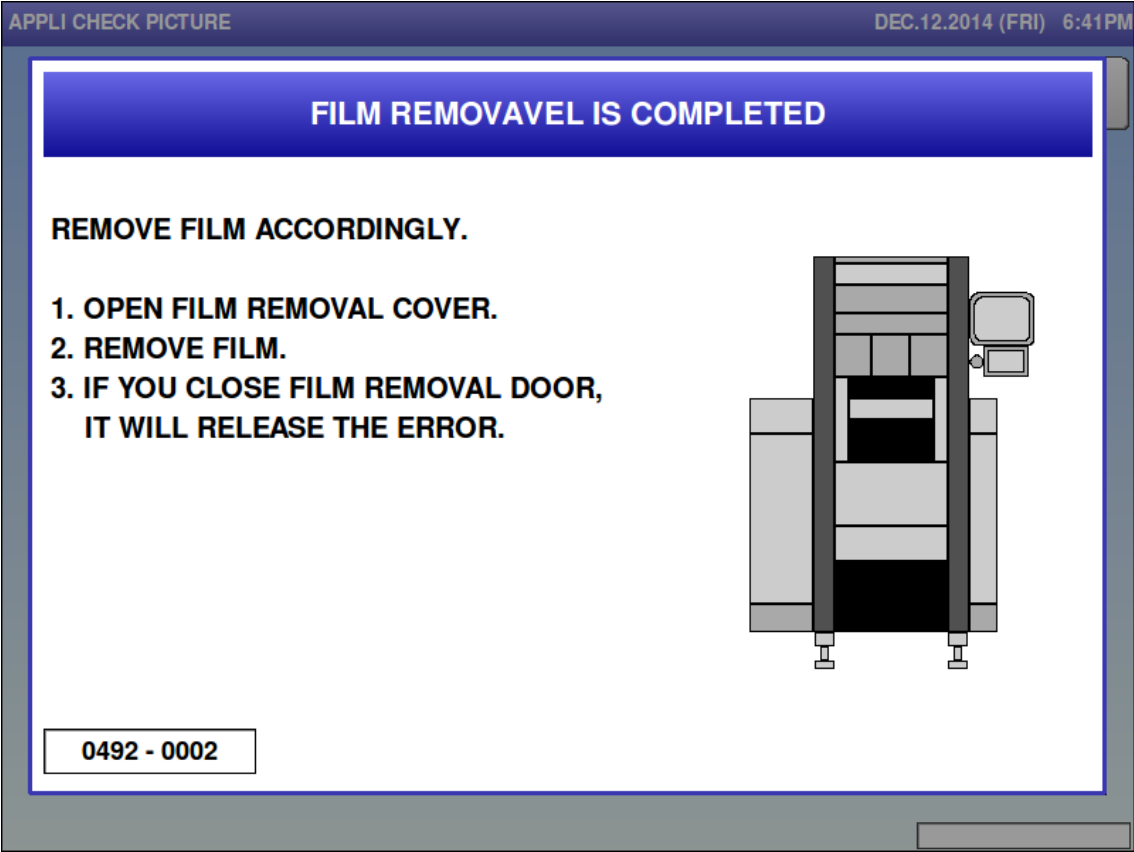

Error content	Film removal is completed.
Detail	Film removal is completed.
Solution	Open the film remove cover, remove film, and close the door.
Action by user	
Action by service representative	
Related part	
Remarks	

■ Problem on wrapping part (494)

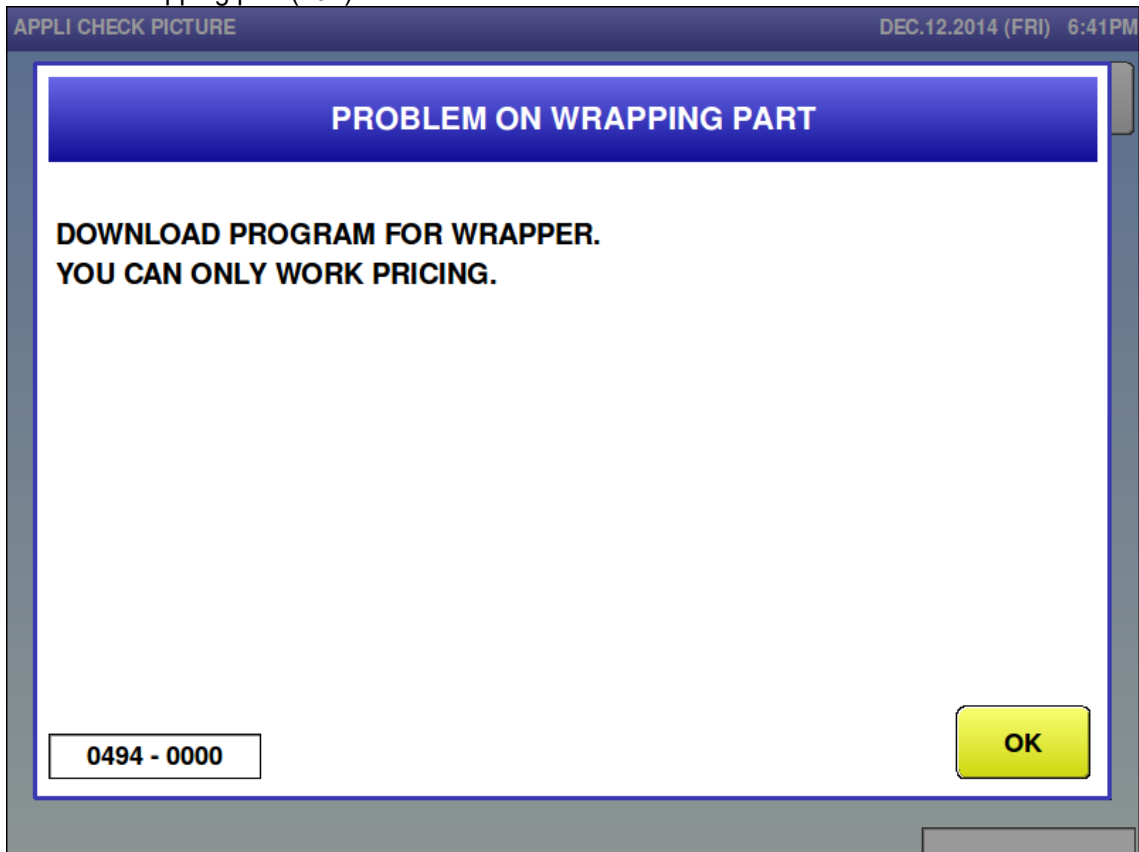

Error content	Wrapper application program is not installed.
Detail	<p>Wrapper application program is not installed (Not downloaded correctly). Sub-error meanings are as follows: 0000: When the [A200] board is replaced to new one. (Application program checksum doesn't match.) 0001: Failure transitioning to the application. 0009: Either of [A100], [A200], or [A300] board is replaced to new one. (Application program checksum of all the boards is not always the same.)</p>
Solution	[OK] button
Action by user	
Action by service representative	
Related part	
Remarks	Download wrapper application program - firmware sub apps - as needed.

■ Sum value for receiving is abnormal (495)

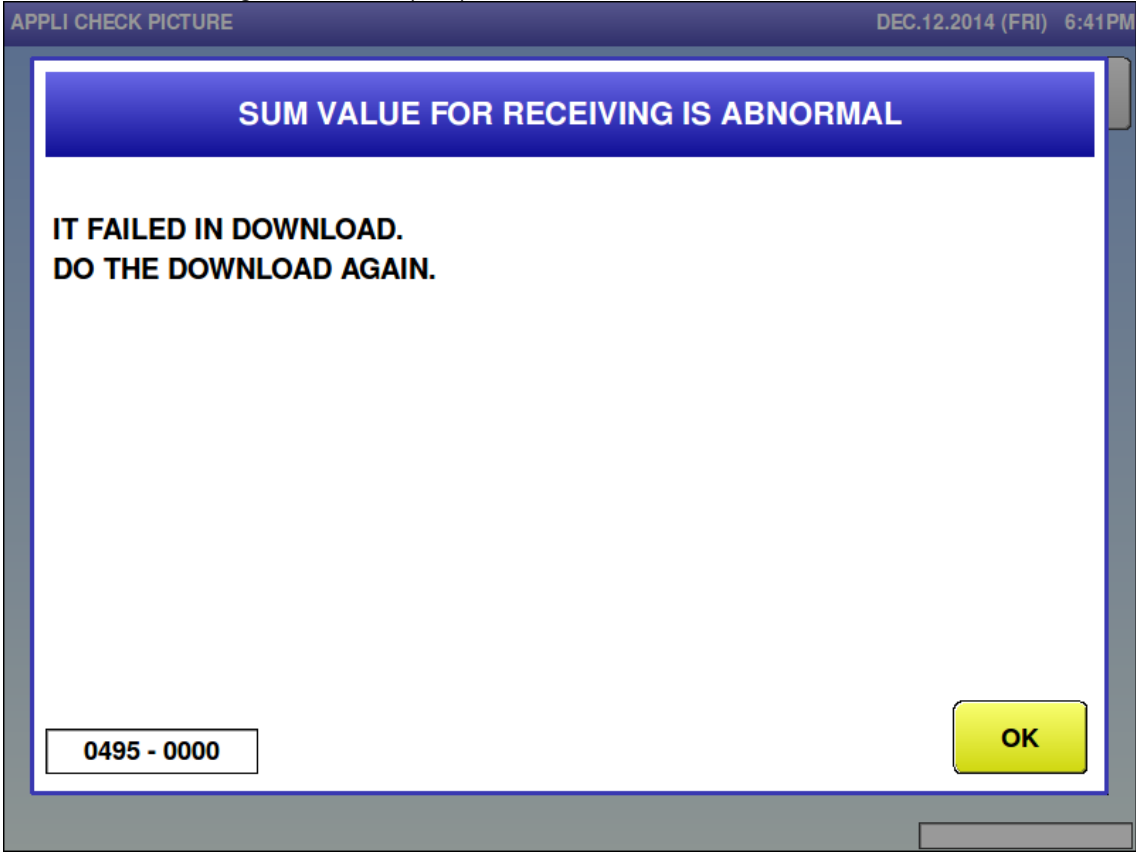

Error content	Sum value for receiving is abnormal.
Detail	The program data sum value received from the wrapper is different from the sum value in the message.
Solution	[OK] button
Action by user	
Action by service representative	
Related part	
Remarks	Re-download

■ Writing for flash ROM is busy (496)

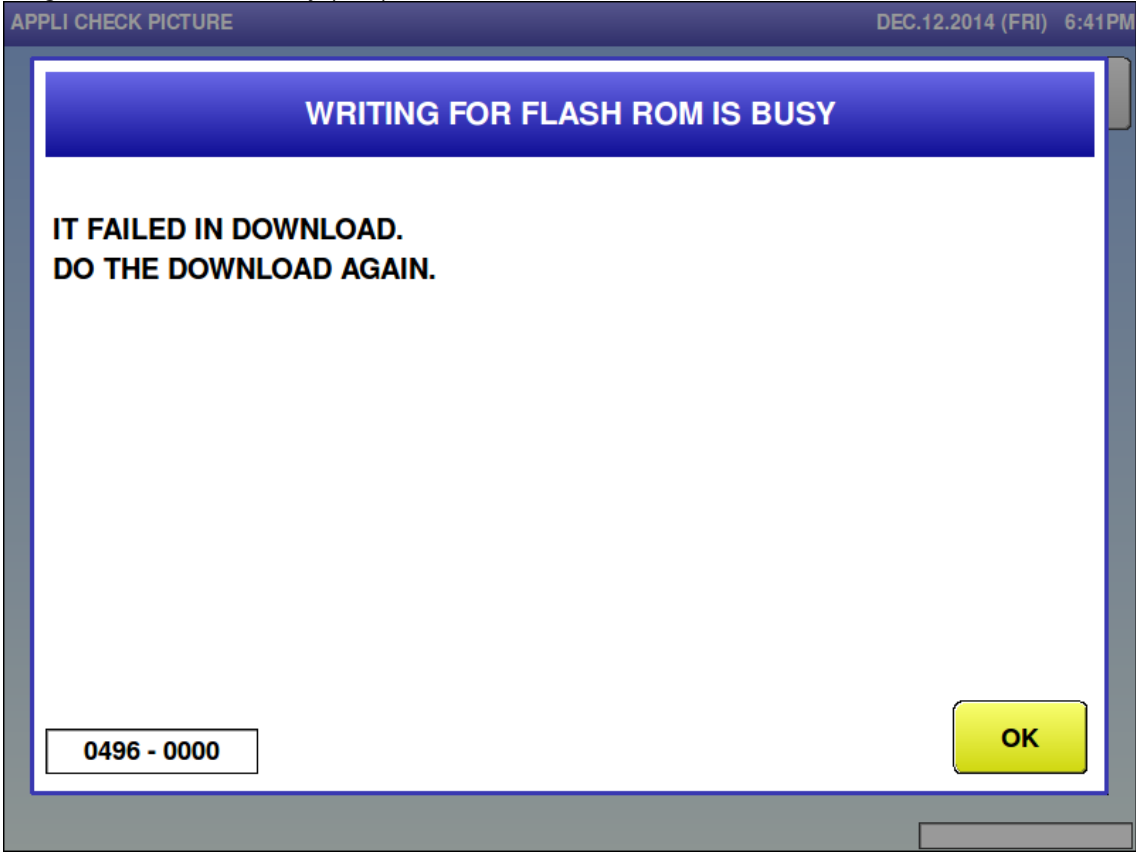

Error content	Flash ROM write condition exceeded the specified time amount.
Detail	Does not change even if the flash ROM write condition exceeds the specified time amount in wrapper application program download.
Solution	[OK] button
Action by user	
Action by service representative	
Related part	
Remarks	Re-download

■ Failed in writing in flash ROM (497)

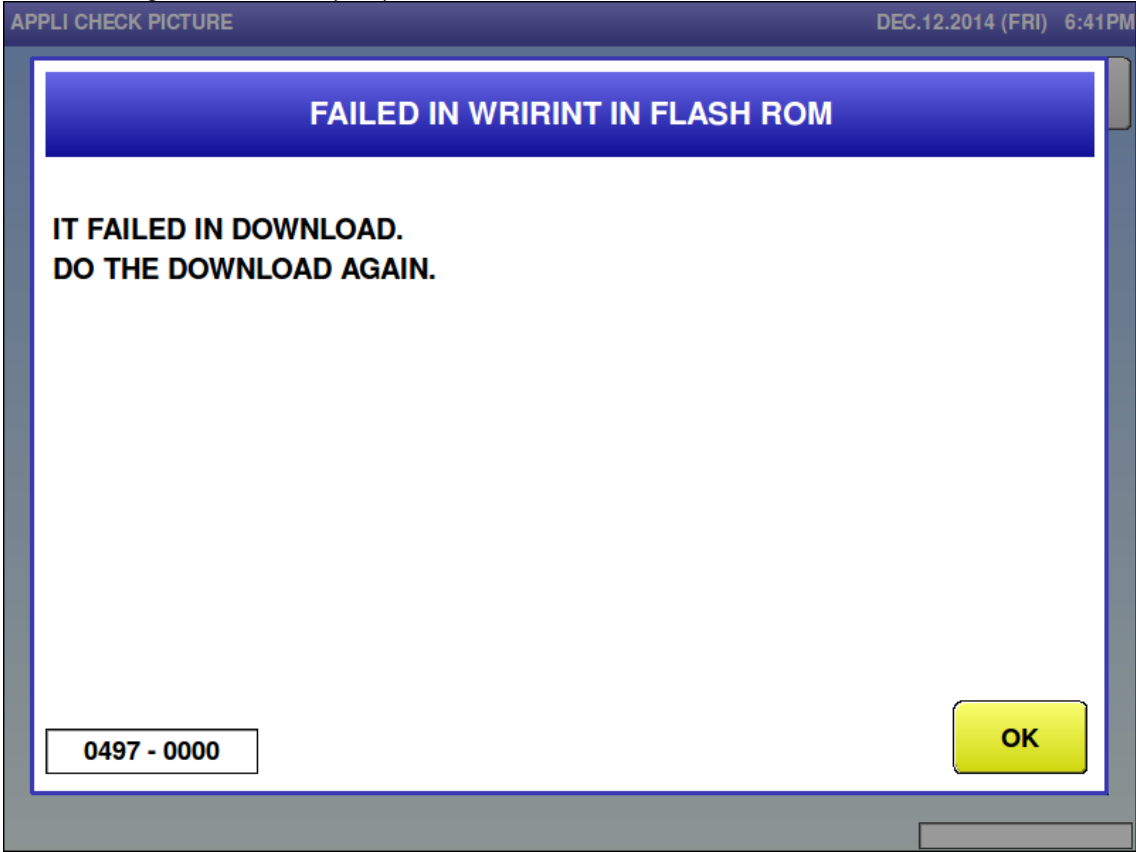

Error content	Flash ROM write-in error in wrapper program download.
Detail	An error occurred when writing program data received from the wrapper to the flash ROM. Sub-error meanings are as follows: 0001: Flash ROM erasure failure. 0002: Application program flash ROM write-in failure. 0003: Application program sum value flash ROM write-in error. 0004: Message sequence extending to flash ROM write-in is mismatched. 0005: Received a download command even though it is not in boot mode (during application program operation).
Solution	[OK] button
Action by user	
Action by service representative	
Related part	Confirm that all 2, 3 and 4 of DIP switch 1 of P-1105 [A100, A200, A300] are OFF.
Remarks	Re-download

■ Problem on wrapping part (498)

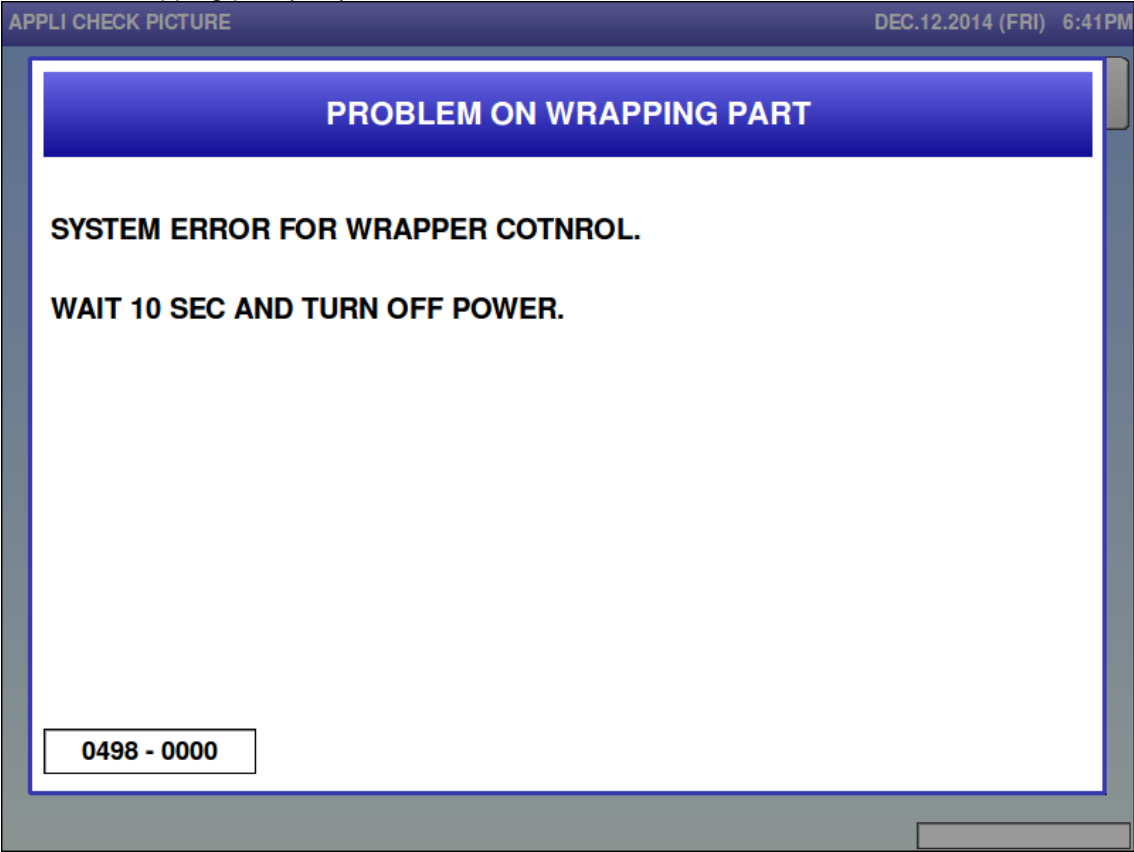

Error content	Wrapper system error.
Detail	<p>A malfunction occurred in the wrapper program. Sub-error meanings are as follows:</p> <p>001X to 003X: CAN communications are not synchronized.</p> <p>0012: For a wrapping request, only child (A100) received a command / For sending hold instruction, no response was received.</p> <p>0013: For a discharge request, only child (A100) received a command / For sending hold instruction, no response was received.</p> <p>0017: For a wrapping request, only child (A100) received a command / For sending hold instruction, different answer from sending was returned.</p> <p>0018: For a discharge request, only child (A100) received a command / For sending hold instruction, different answer from sending was returned.</p> <p>0022: For a wrapping request, only child(A300) received a command / For sending hold instruction, no response was received.</p> <p>0023: For a discharge request, only child(A300) received a command / For sending hold instruction, no response was received.</p> <p>0027: For a wrapping request, only child(A300) received a command / For sending hold instruction, different answer from sending was returned.</p> <p>0028: For a discharge request, only child(A300) received a command / For sending hold instruction, different answer from sending was returned.</p> <p>0032: For a wrapping request, both of child(A100) and child(A300) received a command / For sending hold instruction, no response was received.</p> <p>0033: For a discharge request, both of child(A100) and child(A300) received a command / For sending hold instruction, no response was received.</p> <p>0037: For a wrapping request, both of child(A100) and child(A300) received a command / For sending hold instruction, different answer from sending was returned.</p>

	<p>0038: For a discharge request, both of child(A100) and child(A300) received a command / For sending hold instruction, different answer from sending was returned.</p> <p>1014: Operation was not completed after the grip operation protection timer run out.</p> <p>1017: Operation was not completed after the cutter operation protection timer run out.</p>
Solution	Restore power
Action by user	
Action by service representative	
Related part	
Remarks	

■ Preparing film set (593—0000)

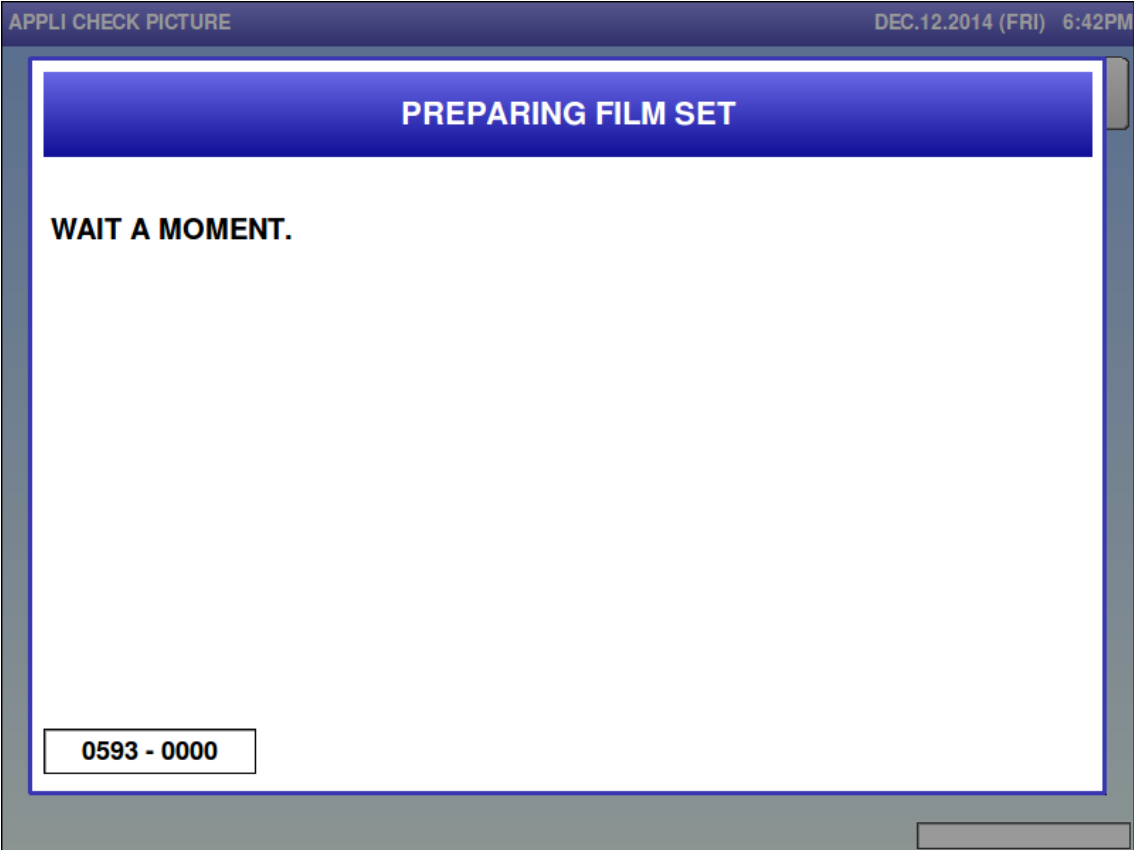

Error content	Preparing film set.
Detail	Message indicates that the insert plate is moving towards the film set position.
Solution	Clears automatically when the insert plate reached the film set position.
Action by user	
Action by service representative	
Related part	
Remarks	Sub-error 0000 is displayed when upper film is set.

■ Preparing film set (593—0001)

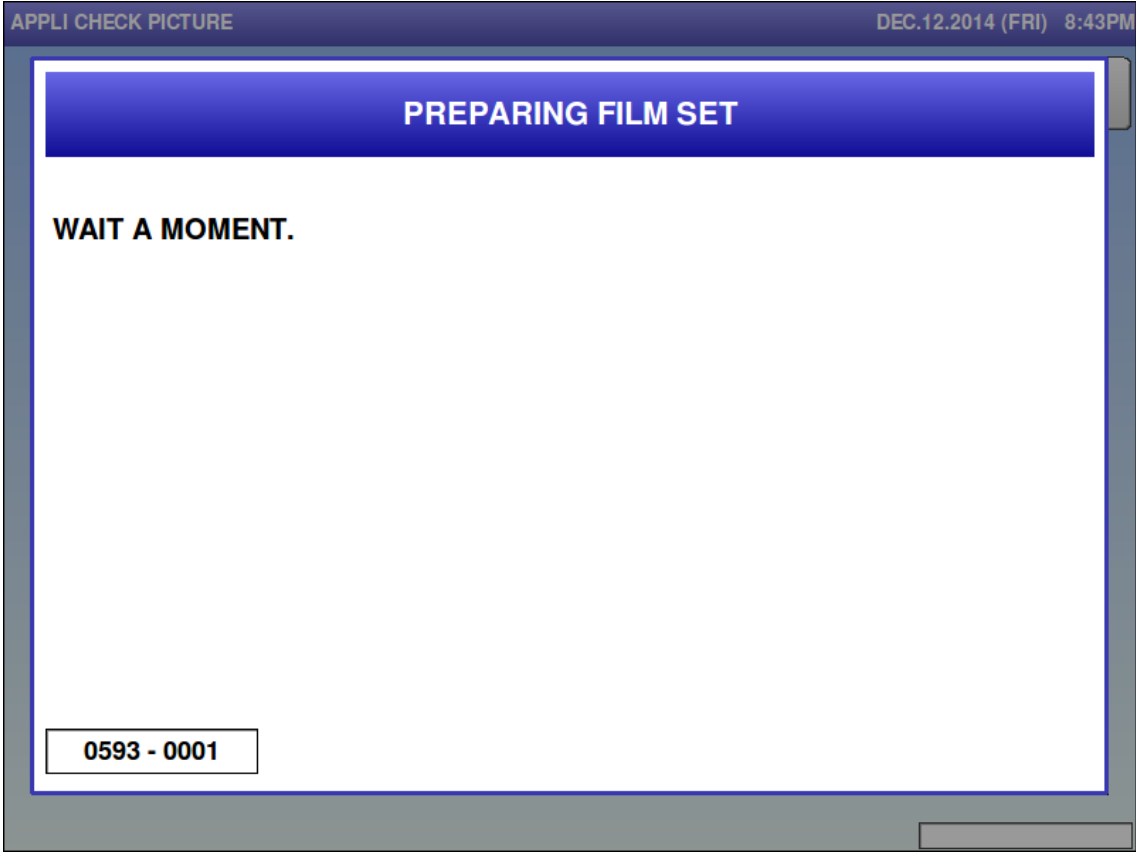

Error content	Preparing film set.
Detail	Message indicates that the insert plate is moving towards the film set position.
Solution	Clears automatically when the insert plate reached the film set position.
Action by user	
Action by service representative	
Related part	
Remarks	Sub-error 0001 is displayed when lower film is set.

■ Film loading instructions (597—0000)

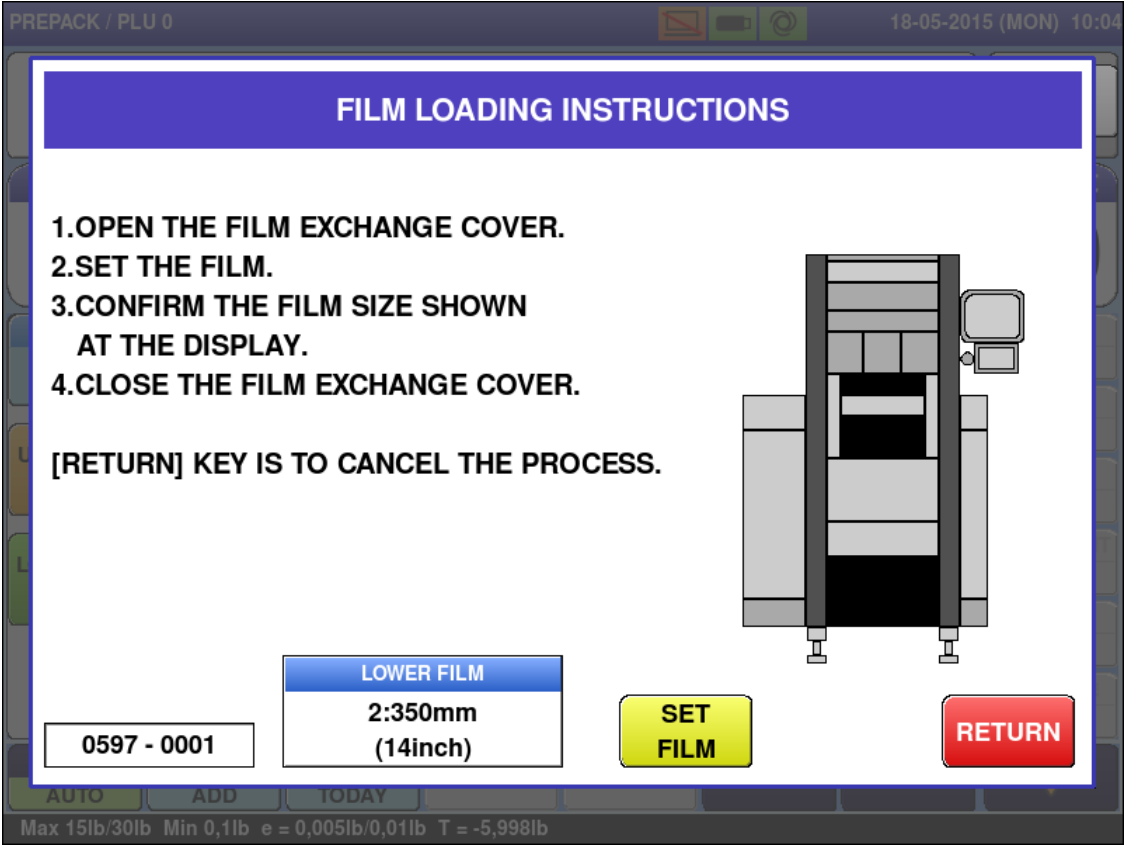

Error content	Film loading instructions.
Detail	Message indicates that the insert plate reached the film set position. Sets the film size or film. [UPPER FILM] sets the upper film size.
Solution	① Press either the [RETURN] button or the [SET FILM] button. [RETURN]: Returns to the original screen. *Film size returns to the original data. [SET FILM]: Sets the film. ② Open the film exchange cover and close the cover after the film is set.
Action by user	
Action by service representative	
Related part	
Remarks	Sub-error 0000 is displayed when upper film is set.

■ Film loading instructions (597-0001)

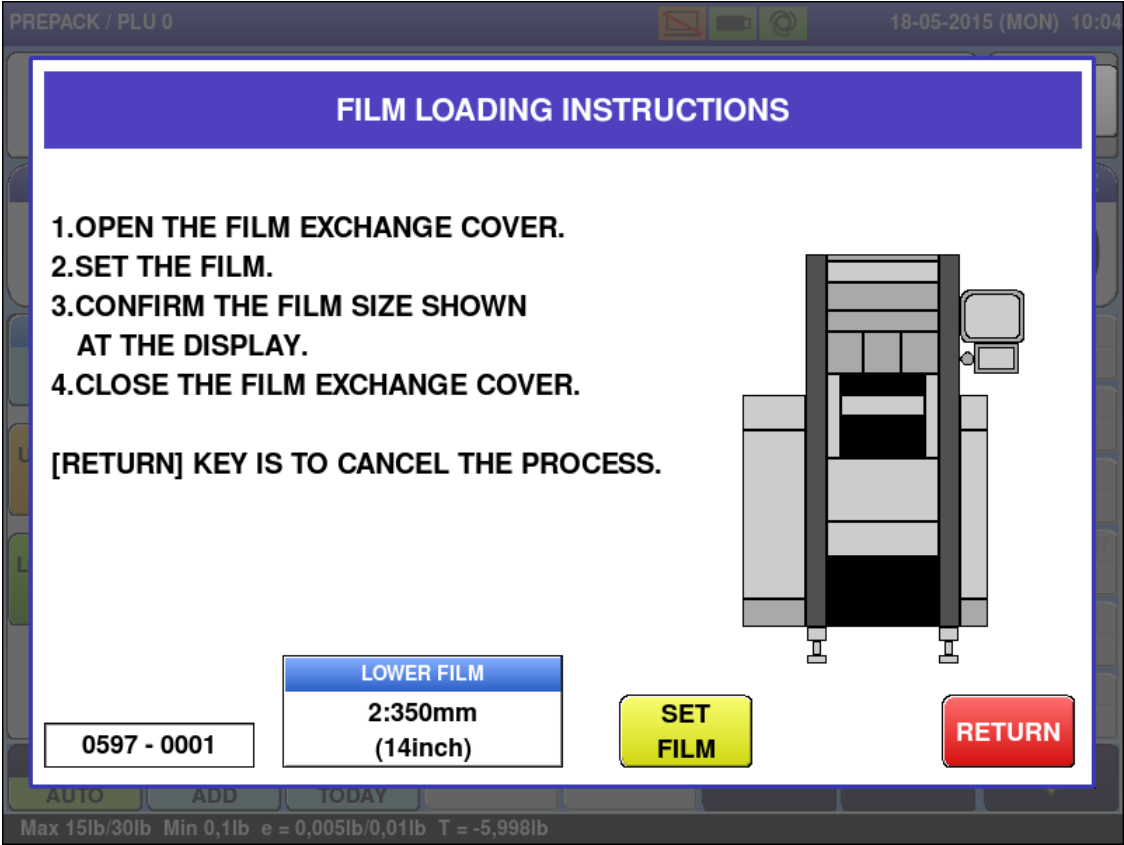

Error content	Film loading instructions.
Detail	Displays until operation of insert plate is completed towards the film set position. Sets the film size or film. [LOWER FILM] sets the lower film size.
Solution	① Press either the [RETURN] button or the [SET FILM] button. [RETURN]: Returns to the original screen. *Film size returns to the original data. [SET FILM]: Sets the film. ② Open the film exchange cover and close the cover after the film is set.
Action by user	
Action by service representative	
Related part	
Remarks	Sub-error 0001 is displayed when lower film is set.

6.3.5 Applicator-related Error (No. 600s)

- No connection with applicator (601)

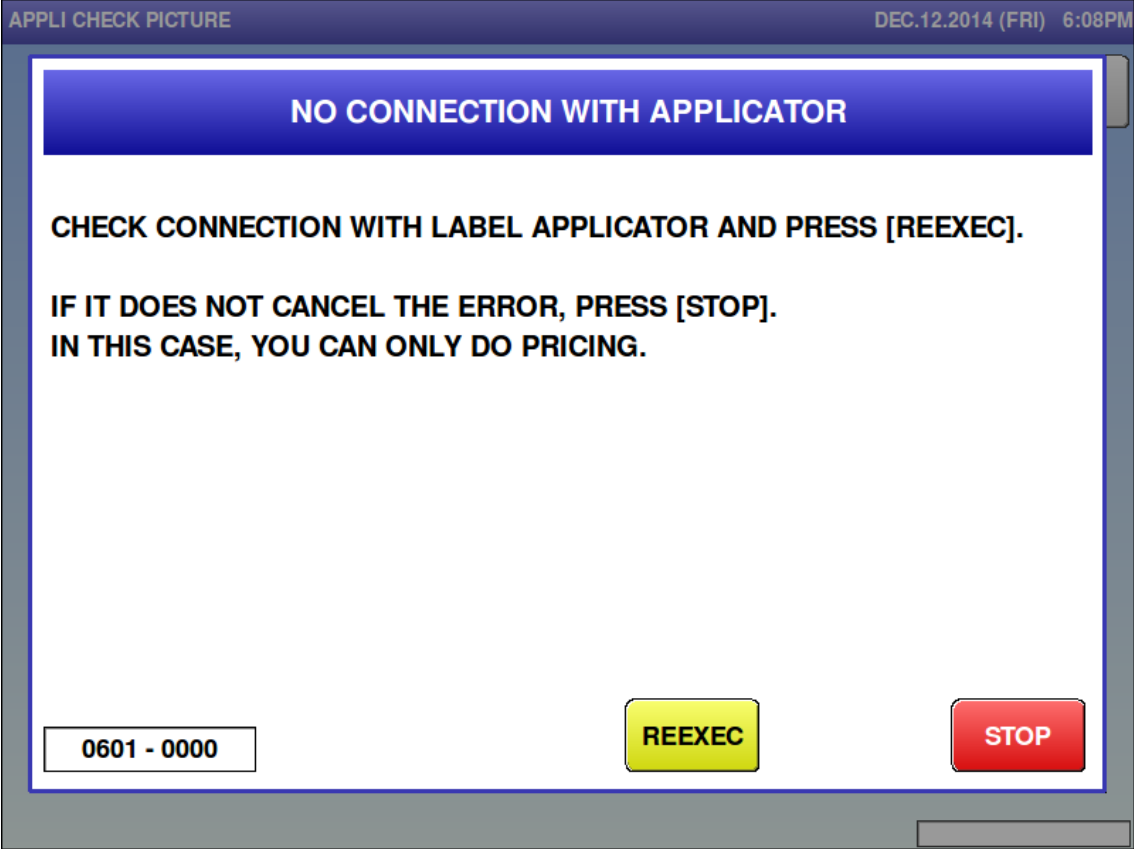

Error content	No connection with applicator.
Detail	<ul style="list-style-type: none">• Communication wasn't achieved between the console and the applicator.• Communication phase number is in the sub-error.• Communication errors after power ON result in this error.
Solution	[STOP] => Cut communication with the applicator. Operate without the applicator. [REEXEC] => Check connection with the applicator. The error is cleared if connection is confirmed.
Action by user	
Action by service representative	
Related part	
Remarks	Operation without the applicator is possible after pressing the [STOP] button.

■ No response from applicator (602)

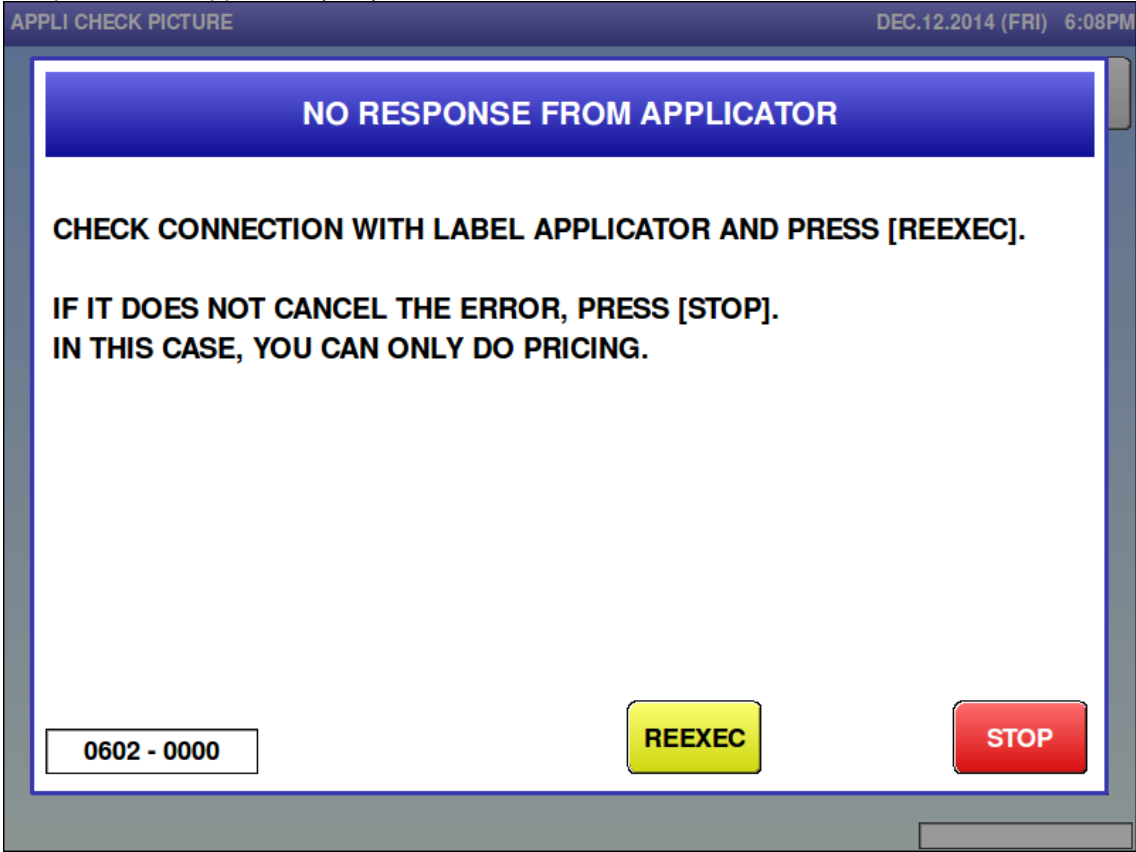

Error content	No response from applicator except for power-on notification.
Detail	<ul style="list-style-type: none">• Communication wasn't achieved between the console and the applicator.• Communication phase number is in the sub-error.• Communication errors after power ON result in this error.
Solution	[STOP] => Cut communication with the applicator. Operate without the applicator. [REEXEC] =>Check connection with the applicator. The error is cleared if connection is confirmed.
Action by user	
Action by service representative	
Related part	
Remarks	Operation without the applicator is possible after pressing the [DTOP] button.

■ Problem on the applicator (603)

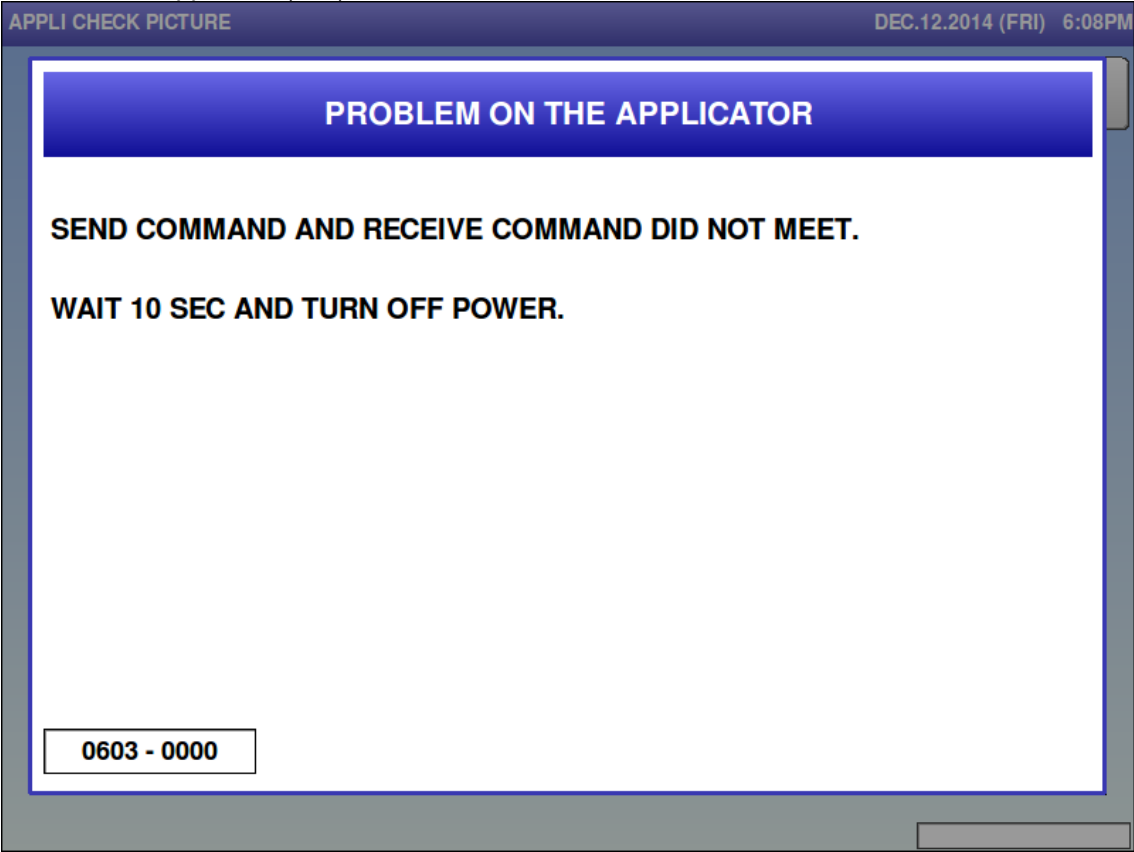

Error content	The command sent to the applicator and the command contained in the answer is different.
Detail	
Solution	Restore power
Action by user	
Action by service representative	
Related part	
Remarks	

■ Blackout for the console (604)

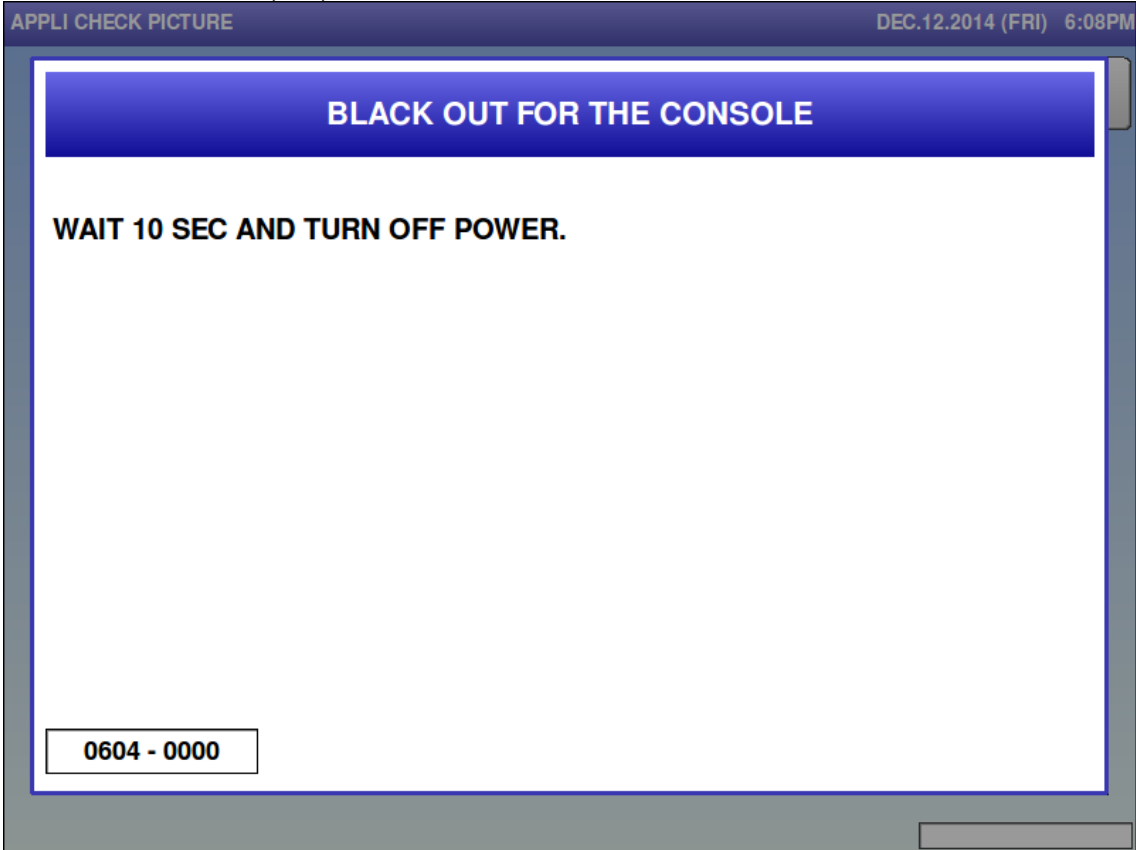

Error content	Power failure detected in the applicator.
Detail	Power ON notification command was received twice from the console.
Solution	Restore power
Action by user	
Action by service representative	
Related part	<ul style="list-style-type: none"> ② 24 V DC to the power supply (XJ12) of P-1105 [A100]. ② RS485 communication cable between main boards (P-1100, P-1163, P-1000) [A10] and P-1105 [A100].
Remarks	

- It detected blackout for the applicator (605)

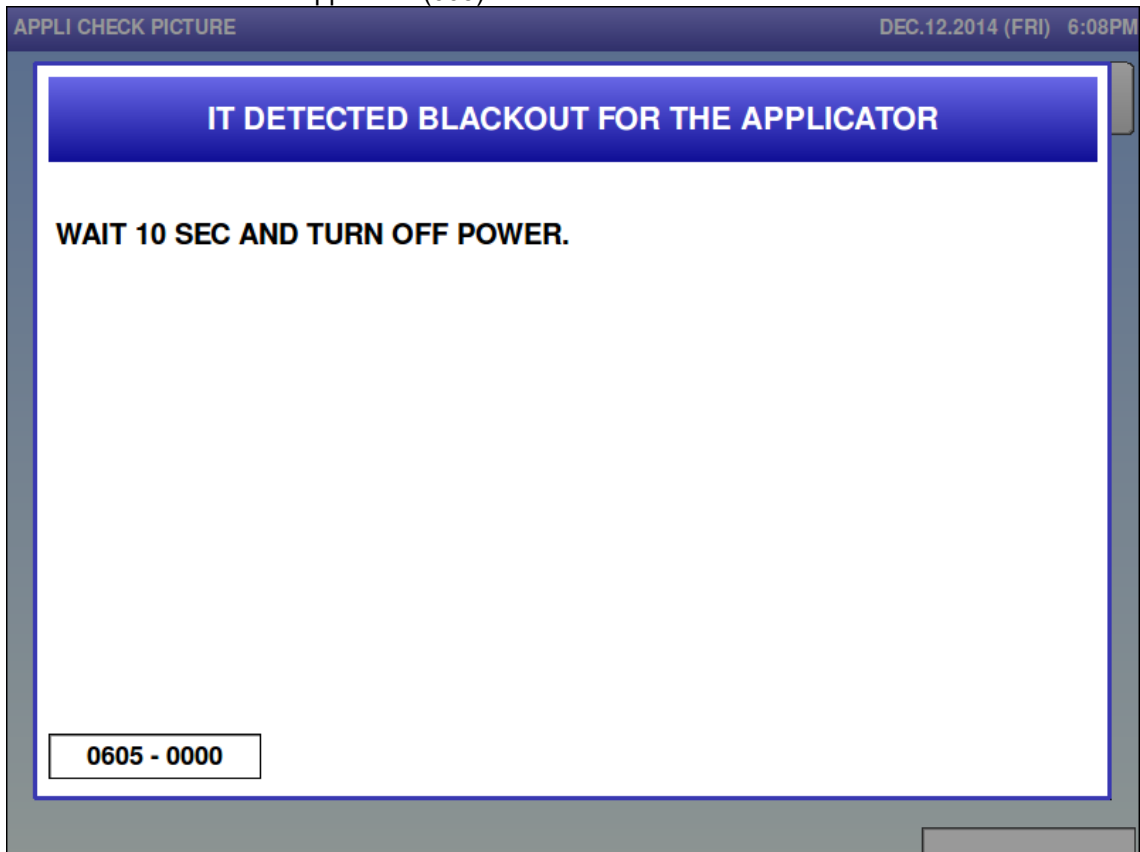

Error content	Applicator CPU was reset.
Detail	Before receiving the acknowledge power ON command, the applicator received a different command.
Solution	Restore power
Action by user	
Action by service representative	
Related part	① 24 V DC to the power supply (XJ12) of P-1105 [A100]. ② RS485 communication cable between main boards (P-1100, P-1163, P-1000) [A10] and P-1105 [A100].
Remarks	

■ Problem on the applicator (606)

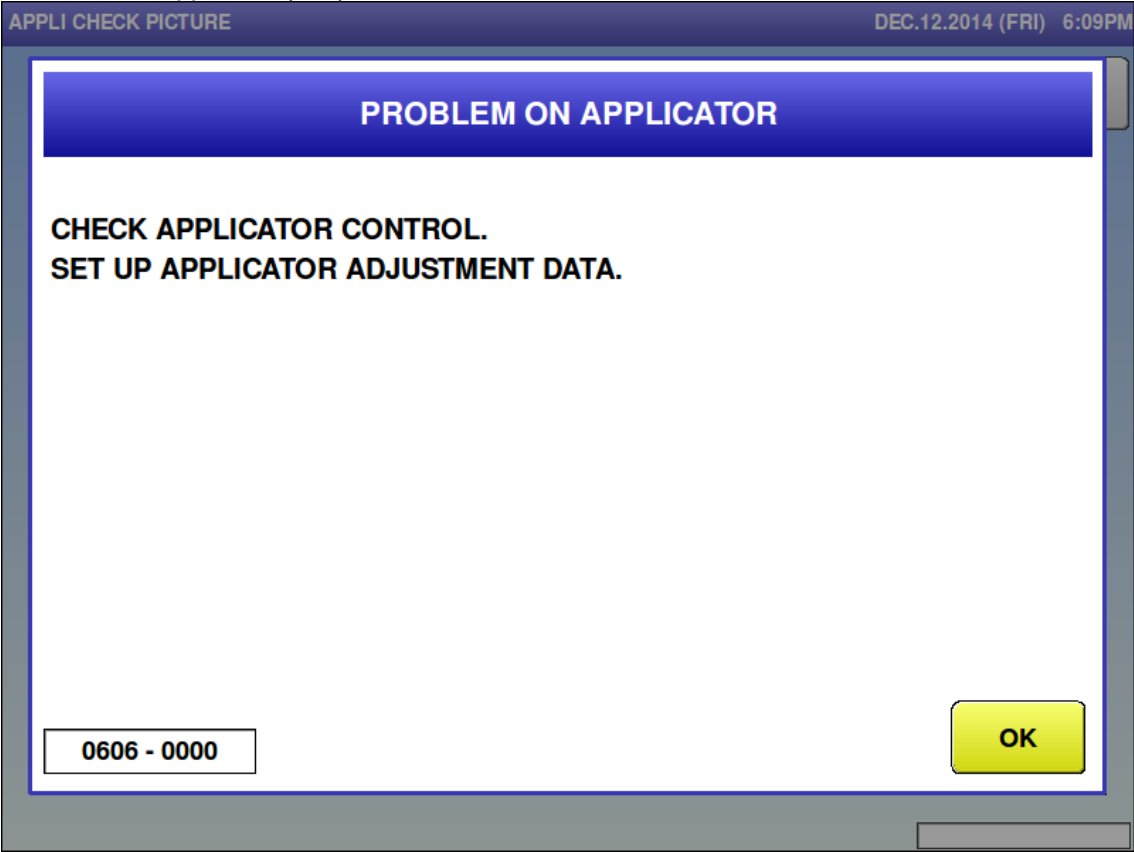

Error content	Applicator alignment data has not been set.
Detail	
Solution	Press the [OK] button; initialize the applicator for the adjustment.
Action by user	
Action by service representative	
Related part	
Remarks	

■ Problem on applicator (607)

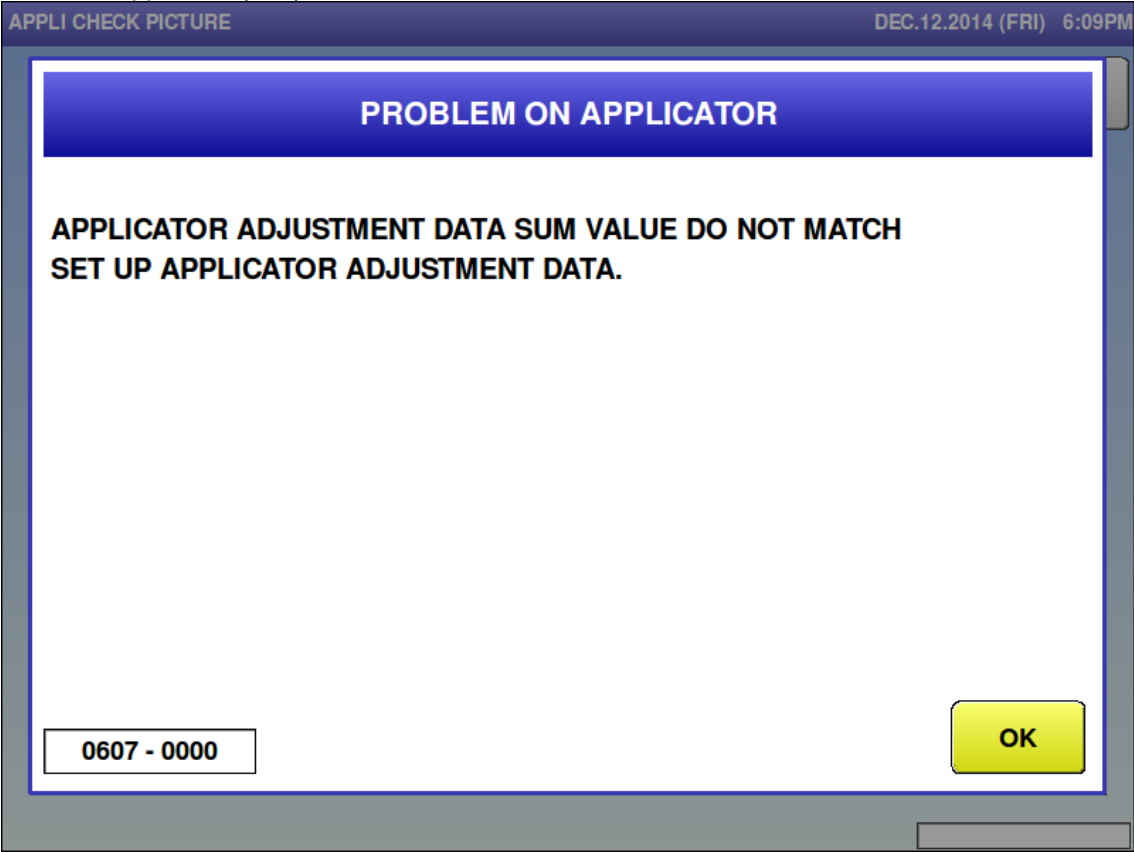

Error content	Applicator data checksum value is abnormal.
Detail	
Solution	Press the [OK] button and adjust the applicator.
Action by user	
Action by service representative	
Related part	
Remarks	

■ Applicator has stopped (608)

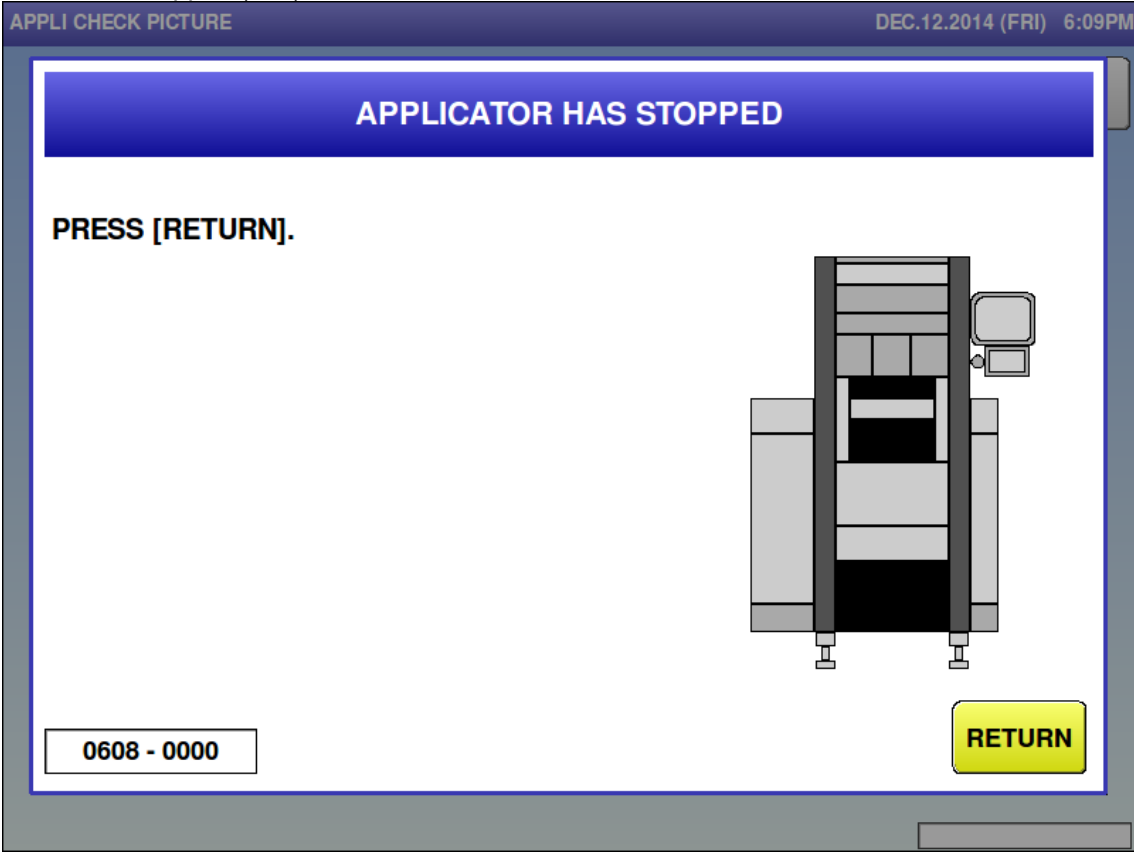

Error content	Applicator has stopped.
Detail	The emergency stop switch was used during applicator operation.
Solution	[RETURN] button
Action by user	
Action by service representative	
Related part	
Remarks	

- It could not suck label (609)

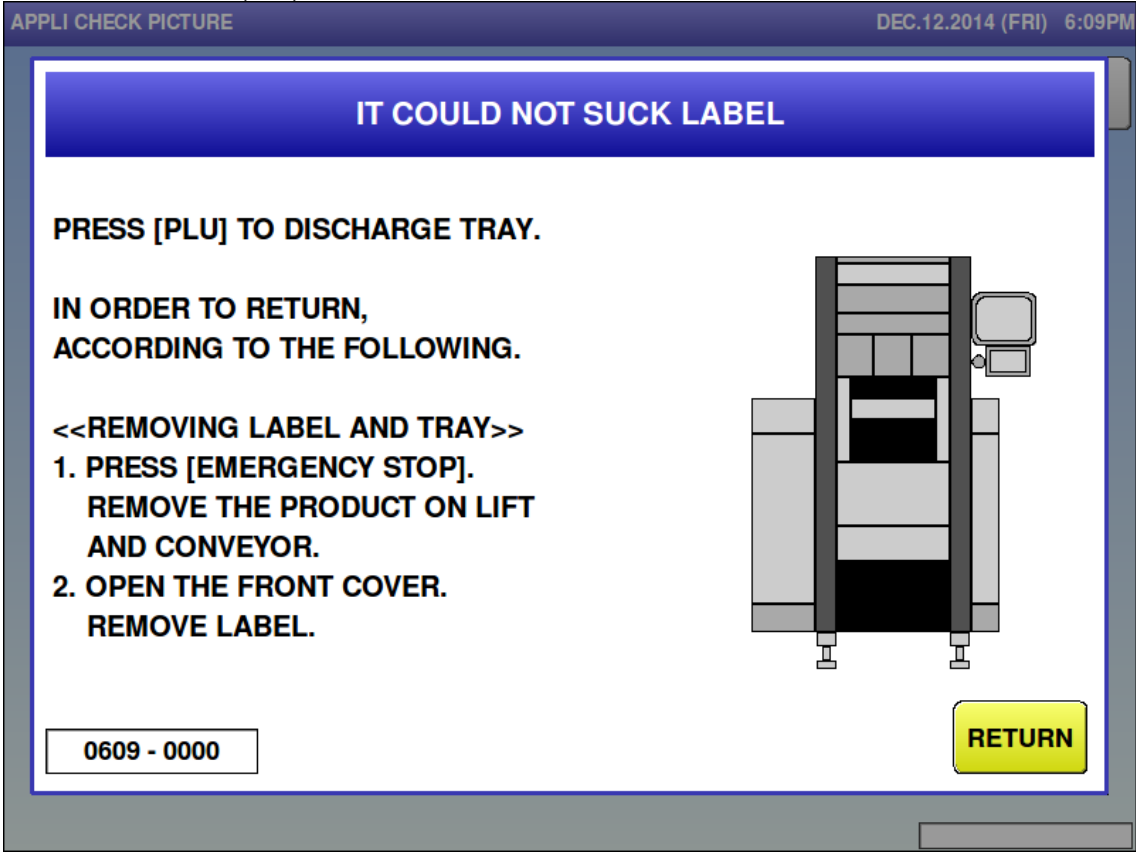

Error content	Applicator failed in label application. The label was not picked up from the label roller table.
Detail	Sub-error meanings are as follows: 0000: Applicator failed in labeled absorption.
Solution	Use either (1) or (2) to clear the error. ① [RETURN] button ② [PLU] button
Action by user	Clean up the label presence sensor.
Action by service representative	Clean up the label presence sensor. Adjust the issue position by printing adjustment. Adjust the suction position on the printer adjustment screen.
Related part	① P-1105 [A100] ② P-1006 [A101] ③ Label presence [B116] ④ Label suction fan [M107]
Remarks	

■ No label to apply (610)

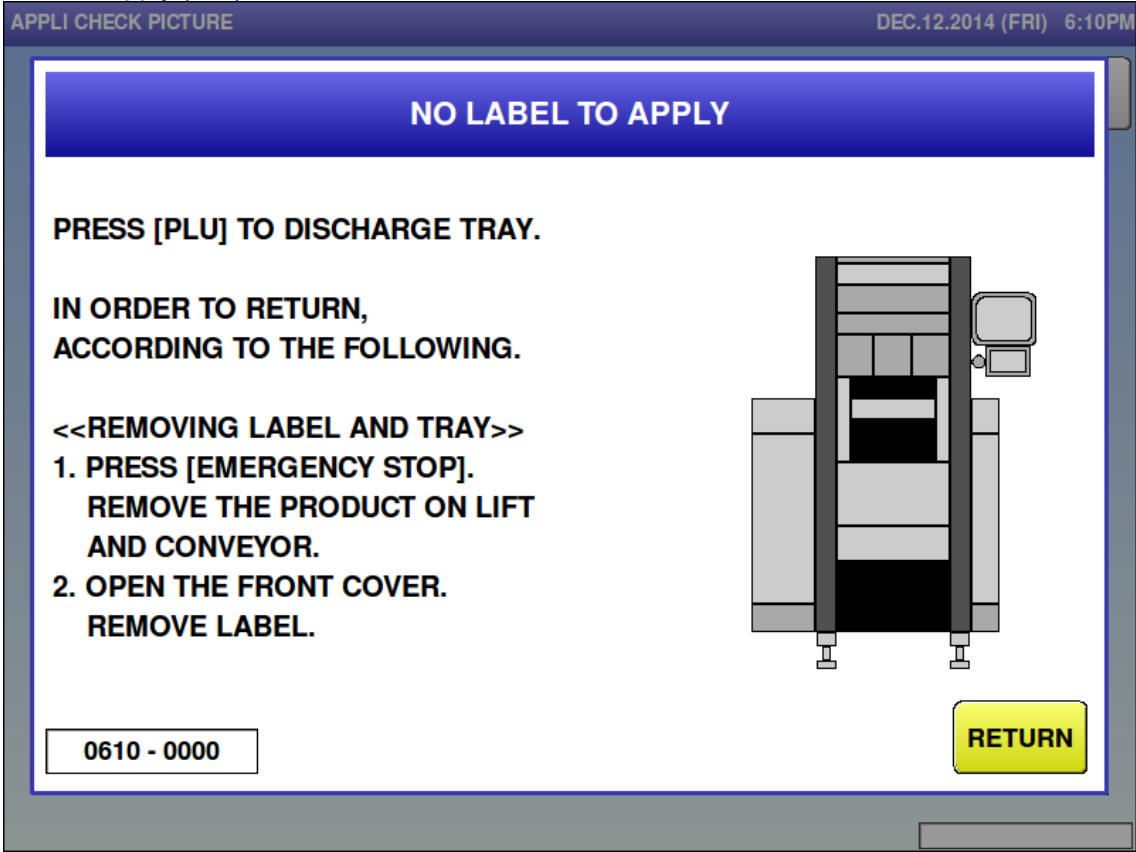

Error content	No label to apply. The label was lost between the label roller table and application to the package.
Detail	There was no label when application was attempted Sub-error meanings are as follows: 0000: Applicator failed in labeled absorption.
Solution	[RETURN] button
Action by user	Clean up the label presence sensor
Action by service representative	Clean up the label presence sensor
Related part	① P-1105 [A100] ② P-1006 [A101] ③ Label presence [B116] ④ Label suction fan [M107]
Remarks	

■ Missed to apply label (611)

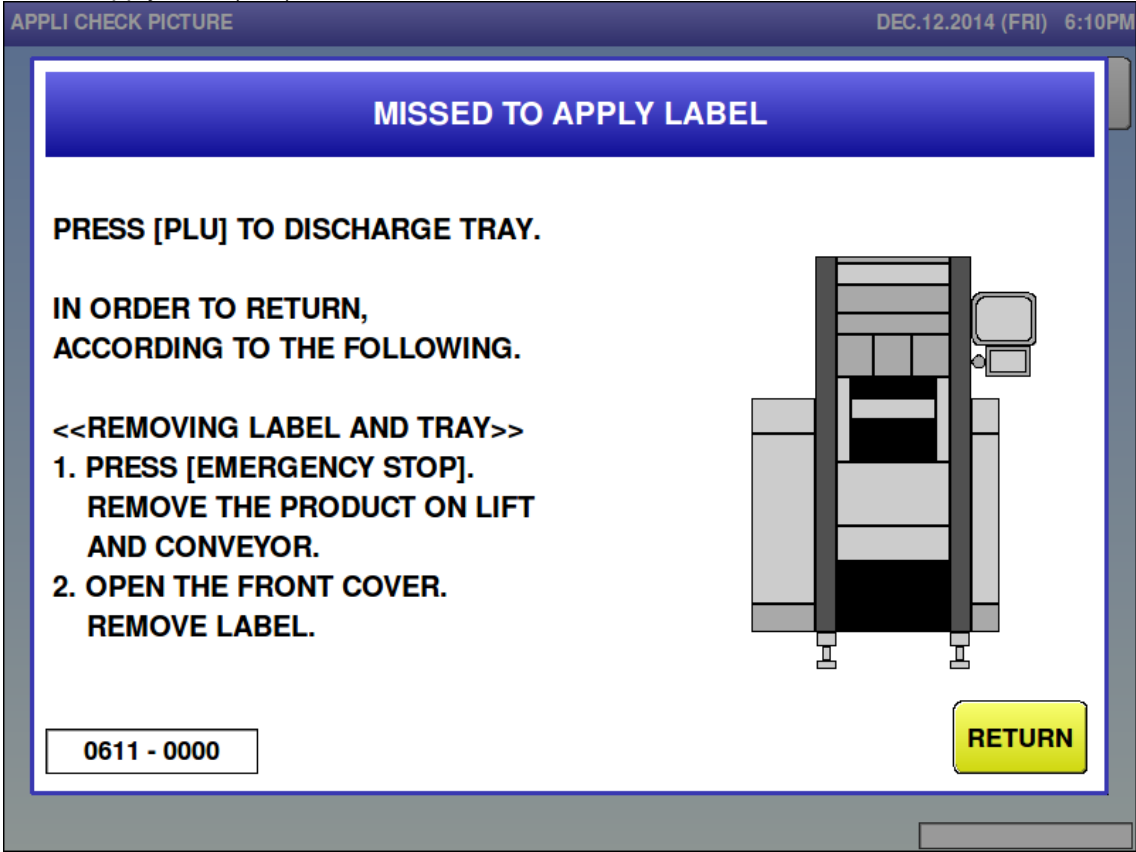

Error content	Missed to apply label.
Detail	Sub-error meanings are as follows: 0000: Pasting preparation was not completed when pasting time was run out. 0001: Previous pasting was not completed when pasting timing signal was received. 0002: The tray height message was not received when the pasting timing signal was received.
Solution	[RETURN] button
Action by user	
Action by service representative	
Related part	
Remarks	

■ Missed to apply label (612)

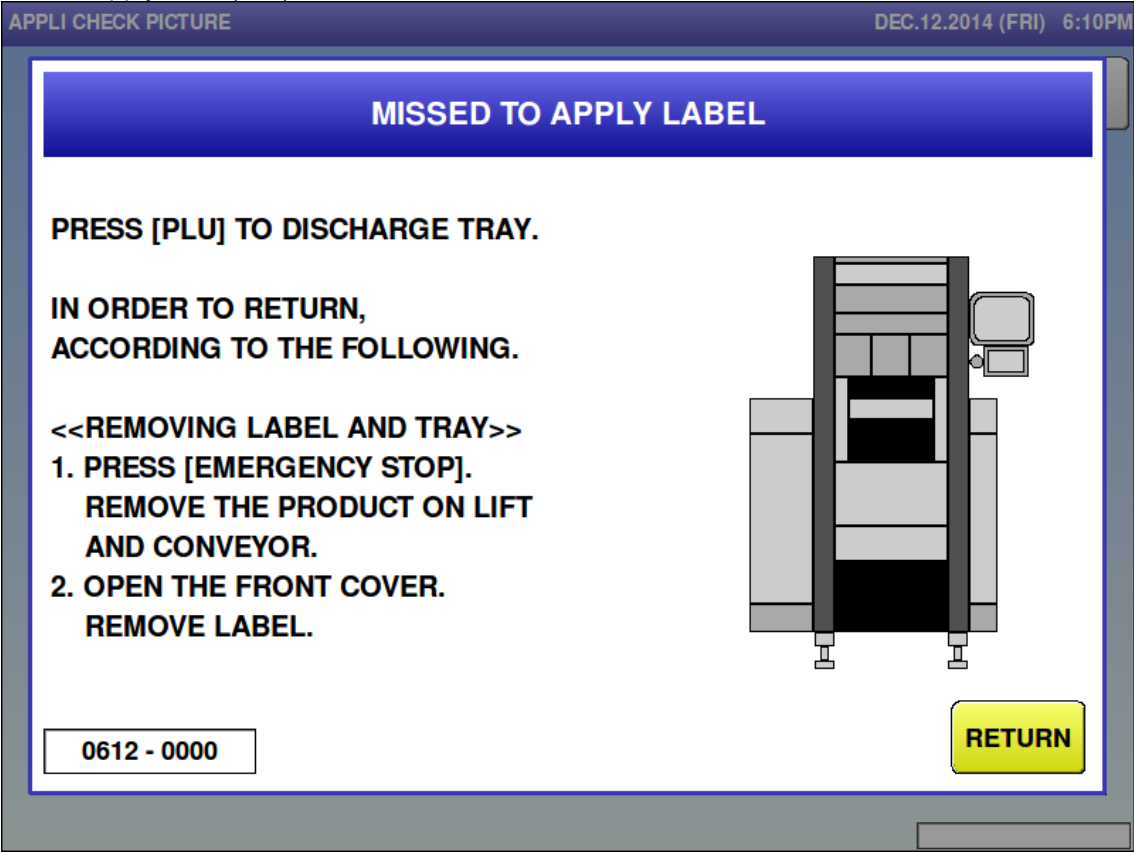

Error content	Missed to apply label.
Detail	Pasting timing signal was not received.
Solution	[RETURN] button
Action by user	
Action by service representative	
Related part	
Remarks	

■ Label is remaining on applicator (613)

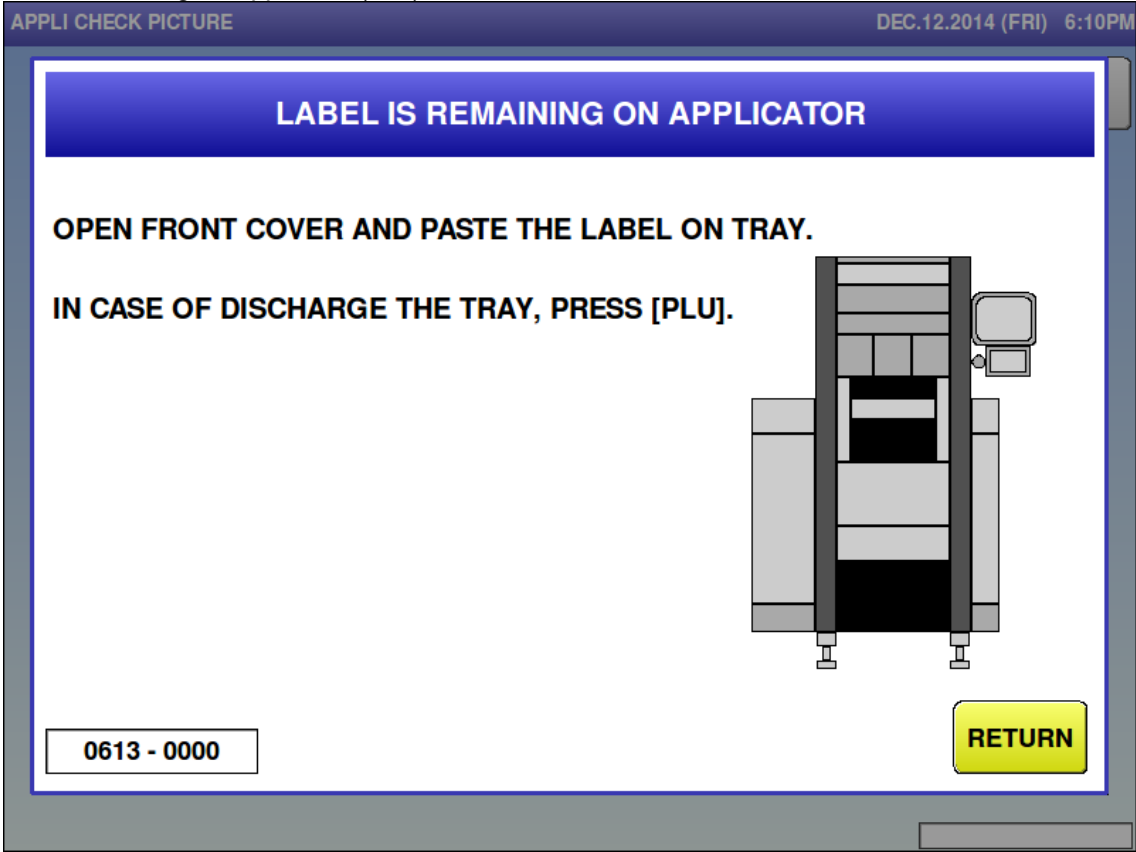

Error content	Label is remaining on applicator.
Detail	A label remains on the applicator after application.
Solution	Press the [RETURN] button after removing the label.
Action by user	Check if the tray height setting matches the actual height.
Action by service representative	Check the pasting height adjustment value if the printing control setting of the printer in adjustment mode is tray height.
Related part	
Remarks	

■ Don't put your hands in (614)

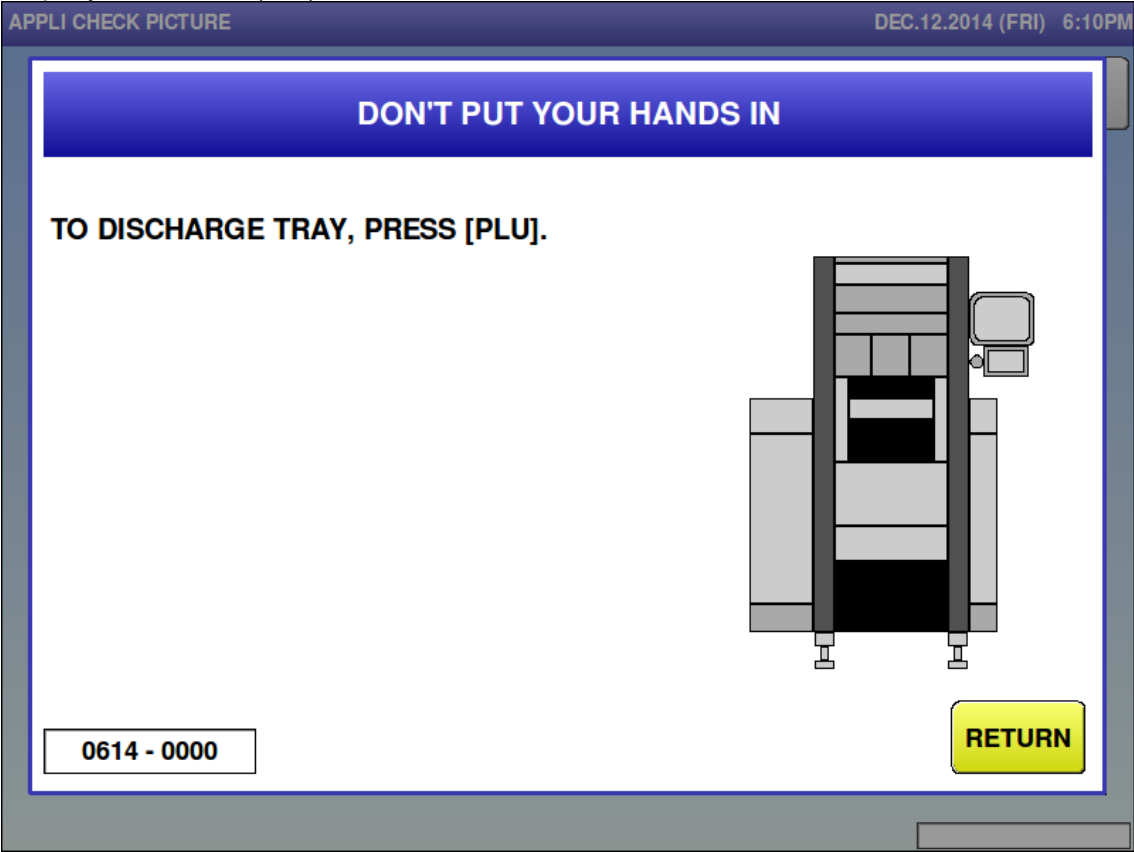

Error content	A hand was put inside the front cover.
Detail	The applicator safety switch did not receive light during applicator operation.
Solution	[RETURN] button
Action by user	
Action by service representative	
Related part	Hand insertion in the front cover (light receiving/emitting) [B107].
Remarks	

■ Abnormal for applicator (615)

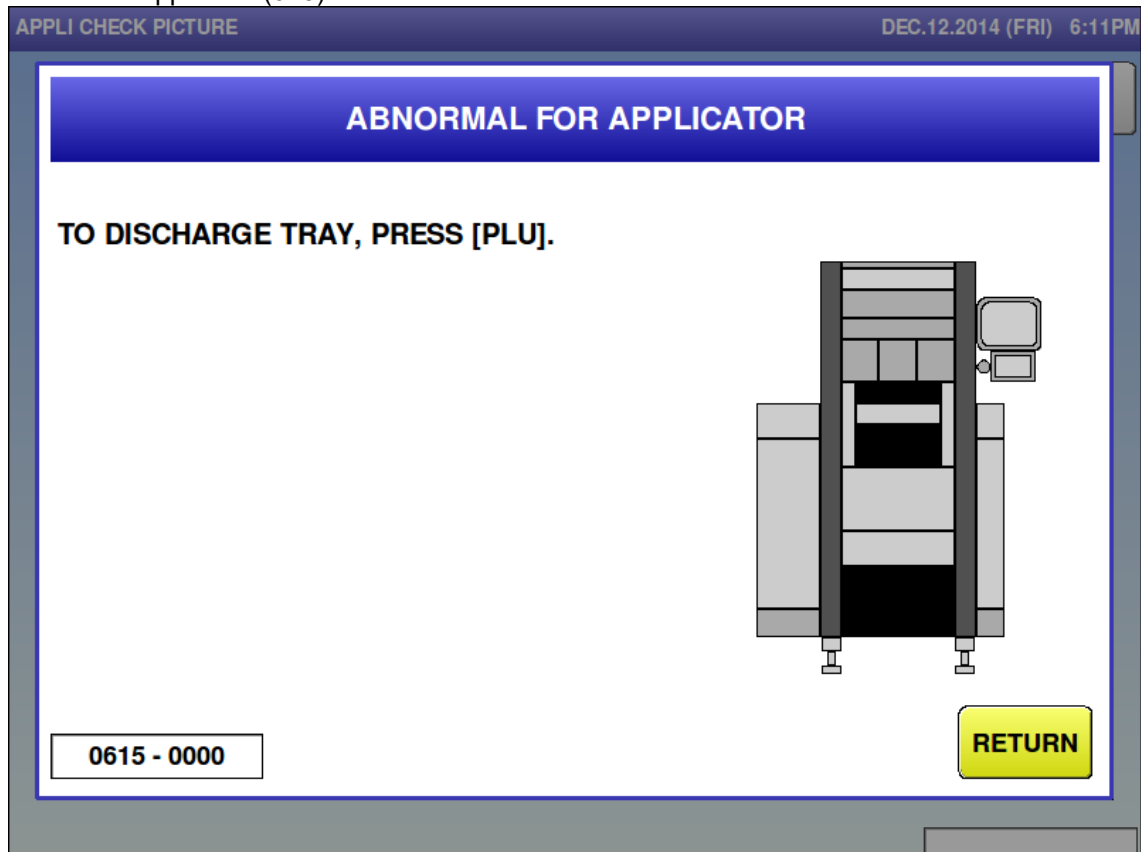

Error content	Abnormal for applicator.
Detail	<p>Operation was not completed within the set time.</p> <p>Sub-error meanings are as follows:</p> <p>000*: X axis (* = 0: moving left, 1: moving right)</p> <p>001*: Y axis (* = 0: moving forward, 1: moving backward)</p> <p>002*: Z axis (* = 0: moving up, 1: moving down)</p> <p>003*: θ axis (* = 0: rotating to right, 1: rotating to left)</p> <p>013*: θ axis (* = 0: rotating to right, 1: rotating to left) In case that a sensor event does not occur after the set time, while operating corrections.</p> <p>0100: Absorption was expected to be done by printer No.1, however, the applicator was moved in front of printer No.2.</p> <p>0101: Absorption was expected to be done by printer No.2, however, the applicator was moved in front of printer No.1.</p>
Solution	[RETURN] button
Action by user	Check if the printer can be moved smoothly with hands with the emergency stop switched pressed.
Action by service representative	Check the grease condition.
Related part	<p><X axis></p> <p>① P-1105 [A100]</p> <p>② P-1006 [A102]</p> <p>③ X-axis motor [M103]</p> <p>④ X-axis origin point [B108]</p> <p>⑤ Printer No.1 position [B109]</p>

	<p>⑥ Printer No.2 position [B110]</p> <p><Y axis></p> <p>① P-1105 [A100]</p> <p>② P-1006 [A101]</p> <p>③ Y-axis motor [M104]</p> <p>④ Y-axis origin point [B111]</p> <p><Z axis></p> <p>① P-1105 [A100]</p> <p>② P-1006 [A101], [A102]</p> <p>③ Z-axis motor [M105]</p> <p>④ Z-axis origin point [B112]</p> <p><θ axis></p> <p>① P-1105 [A100]</p> <p>② P-1006 [A101]</p> <p>③ θ-axis motor [M106]</p> <p>④ Below θ-axis detection board [B113]</p> <p>⑤ Above θ-axis detection board [B114]</p>
<p>Remarks</p>	<ul style="list-style-type: none"> ▪ Check all the sensors. ▪ Check the flags are aligned, secure, and tight. ▪ Initialize the Applicator. ▪ Try downloading the Applicator firmware again before replacing any boards.

■ Abnormal for sensor (616)

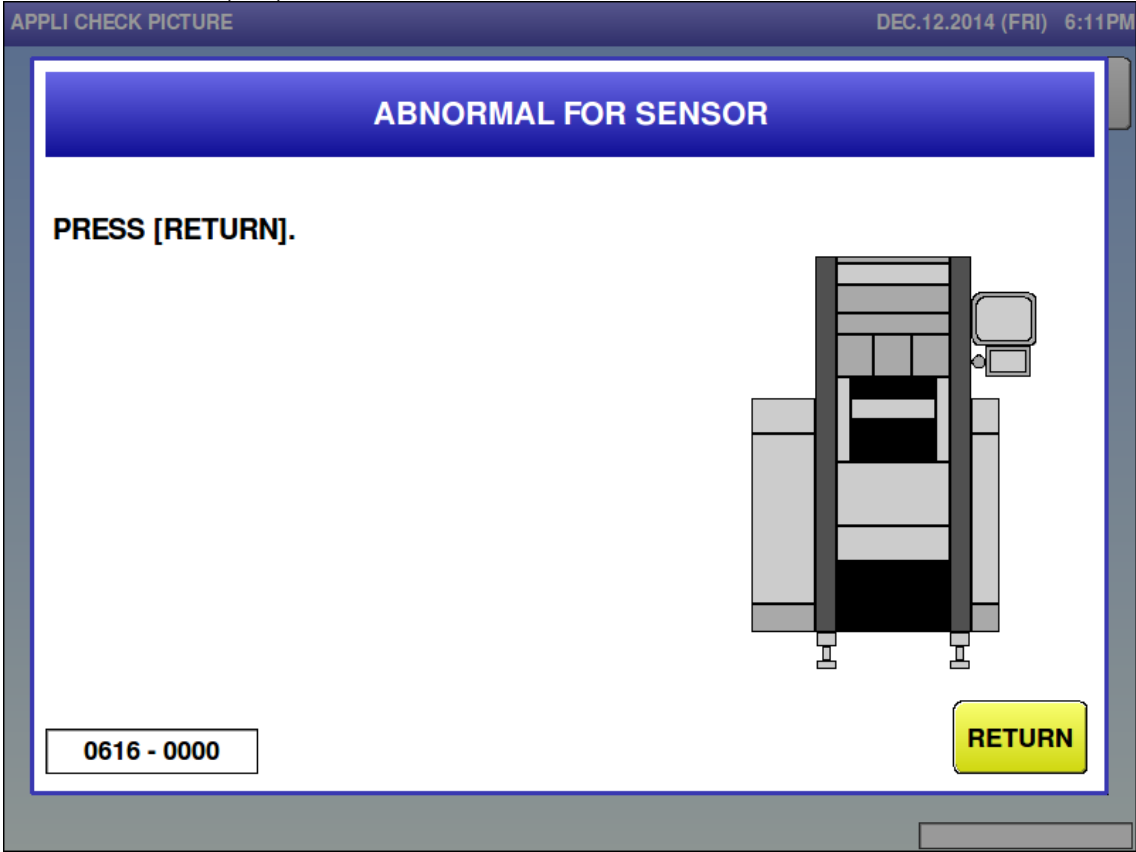

Error content	Abnormal for sensor.
Detail	A sensor that does not have light blocked is blocked from light. Sub-error meanings are as follows: 0000: X axis
Solution	[RETURN] button
Action by user	
Action by service representative	
Related part	① X-axis origin point [B108] ③ Printer No.1 position [B109] ④ Printer No.2 position [B110]
Remarks	

■ Abnormal for the position of applicator (617)

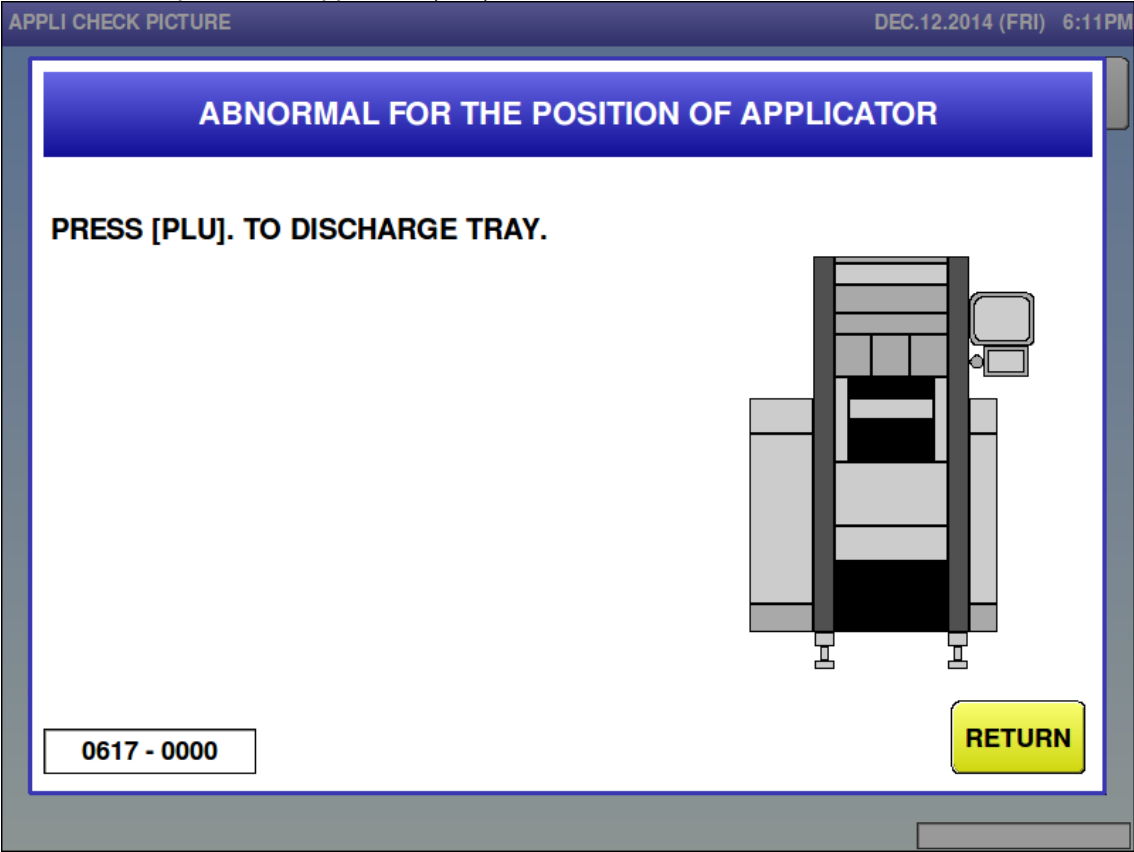

Error content	Abnormal for the position of applicator.
Detail	The original point sensor of Y axis was not blocked from light when applicator attempted to start operation.
Solution	[RETURN] button, [PLU] button
Action by user	
Action by service representative	
Related part	① Y-axis motor [M104] ② Y-axis origin point [B111]
Remarks	

■ Problem on the applicator controller (621)

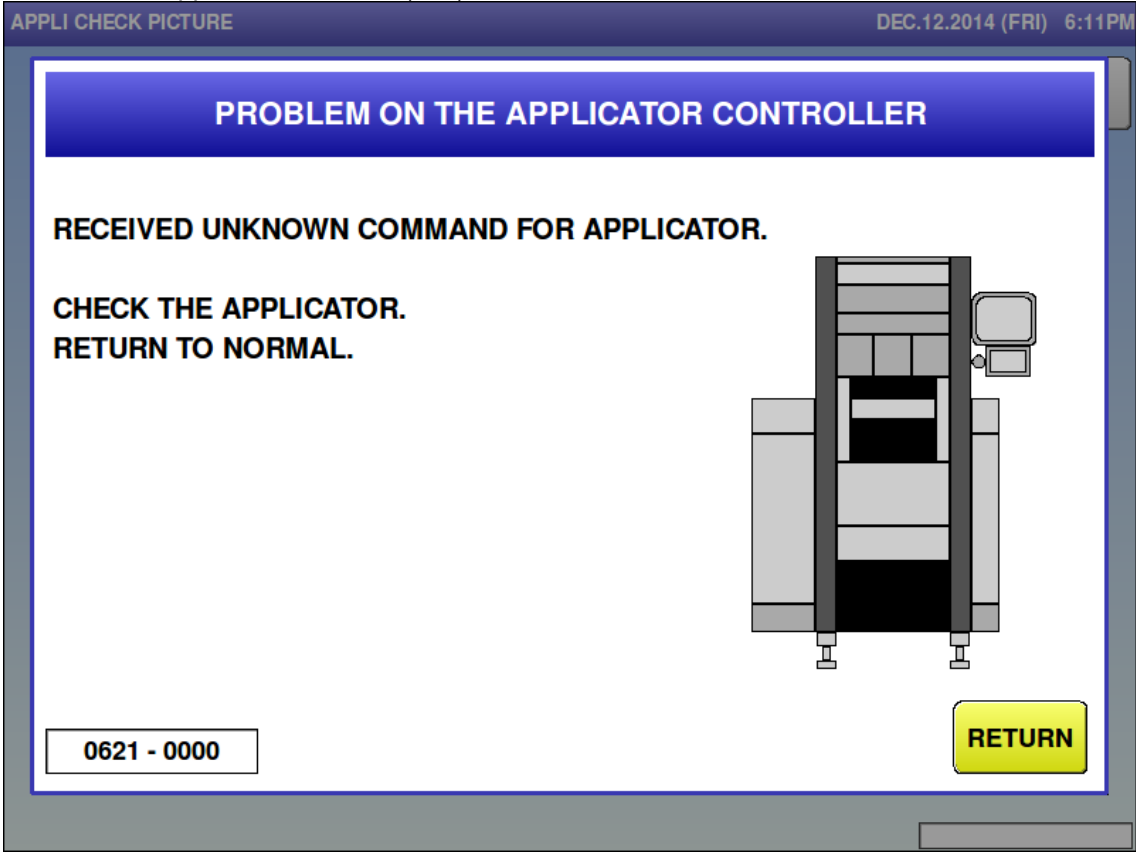

Error content	The applicator is not responding to the command received from the console.
Detail	
Solution	[RETURN] button
Action by user	
Action by service representative	
Related part	
Remarks	Check the main software and applicator software versions and confirm the combination is compatible.

■ No response from applicator (650)

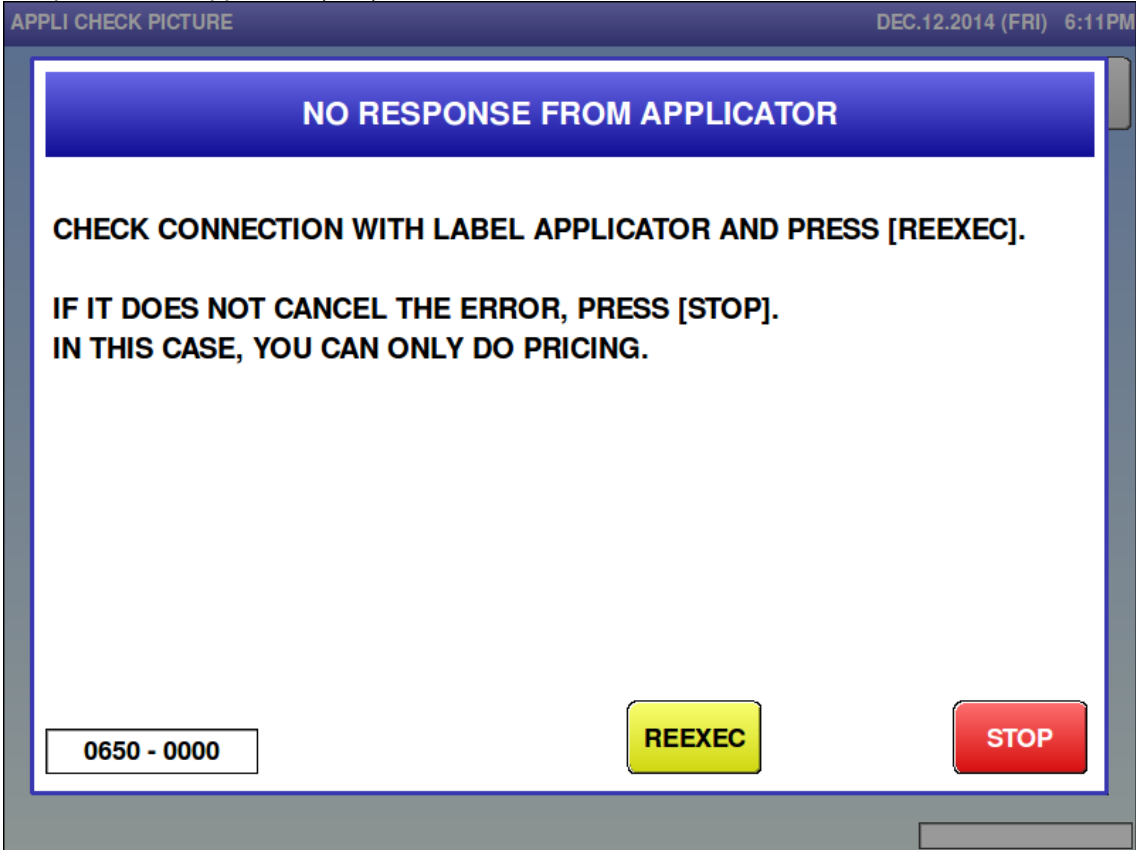

Error content	No response from applicator except for power-on notification.
Detail	<ul style="list-style-type: none">• Communication wasn't achieved between the console and the applicator.• Communication phase number is in the sub-error.• Communication errors after power ON result in this error.
Solution	[STOP]=> Cut communication with the applicator. Operate without the applicator. [REEXEC] => Check connection with the applicator. The error is cleared if connection is confirmed.
Action by user	
Action by service representative	
Related part	
Remarks	Operation without the applicator is possible after pressing the [STOP] button.

6.3.6 Printer-related Error (No. 700s, 800s)

- Printer 1 has problem (703, 803)

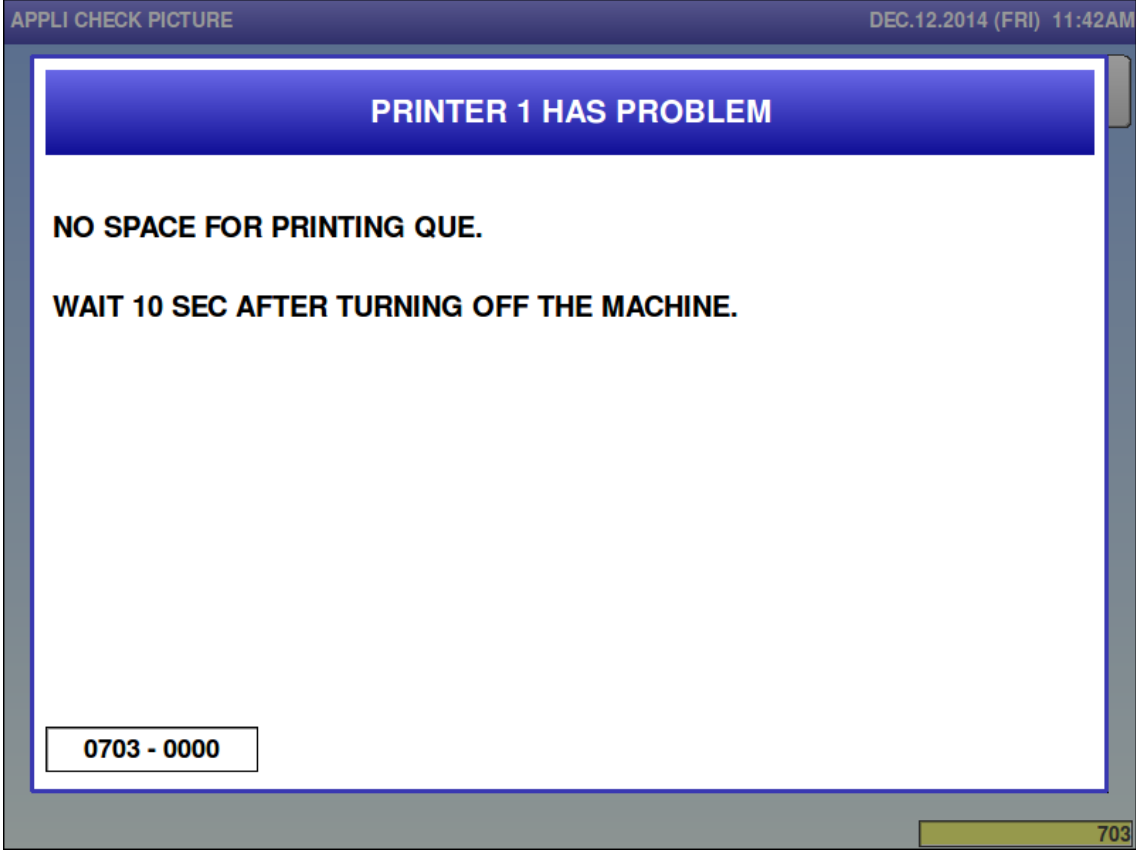

Error content	Printer system error.
Detail	The print queue in main program has error.
Solution	Restore power
Action by user	
Action by service representative	
Related part	
Remarks	“Printer No.1” changes depending on error No.

- Printer 1 has problem (704, 804)

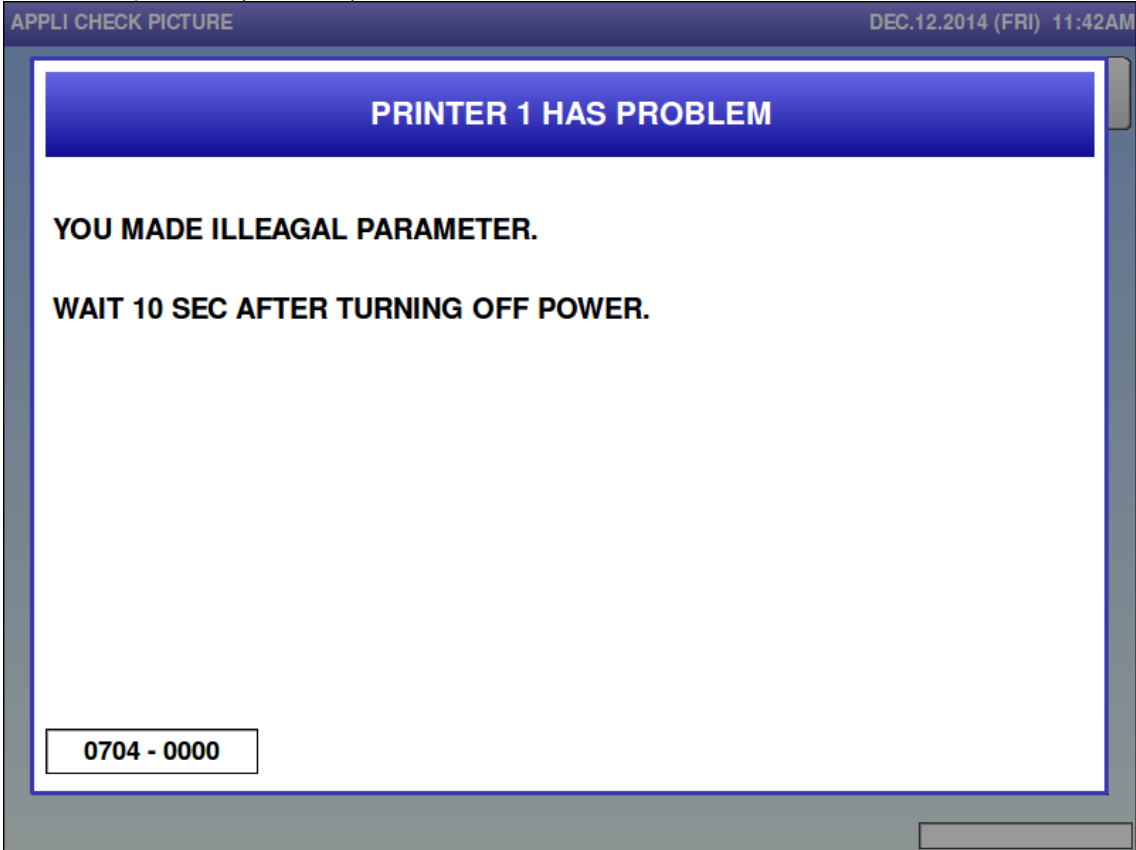

Error content	Printer system error.
Detail	Processed an invalid parameter.
Solution	Restore power
Action by user	
Action by service representative	
Related part	
Remarks	"Printer No.1" changes depending on error No.

■ Printer1 is not initialized (707, 807)

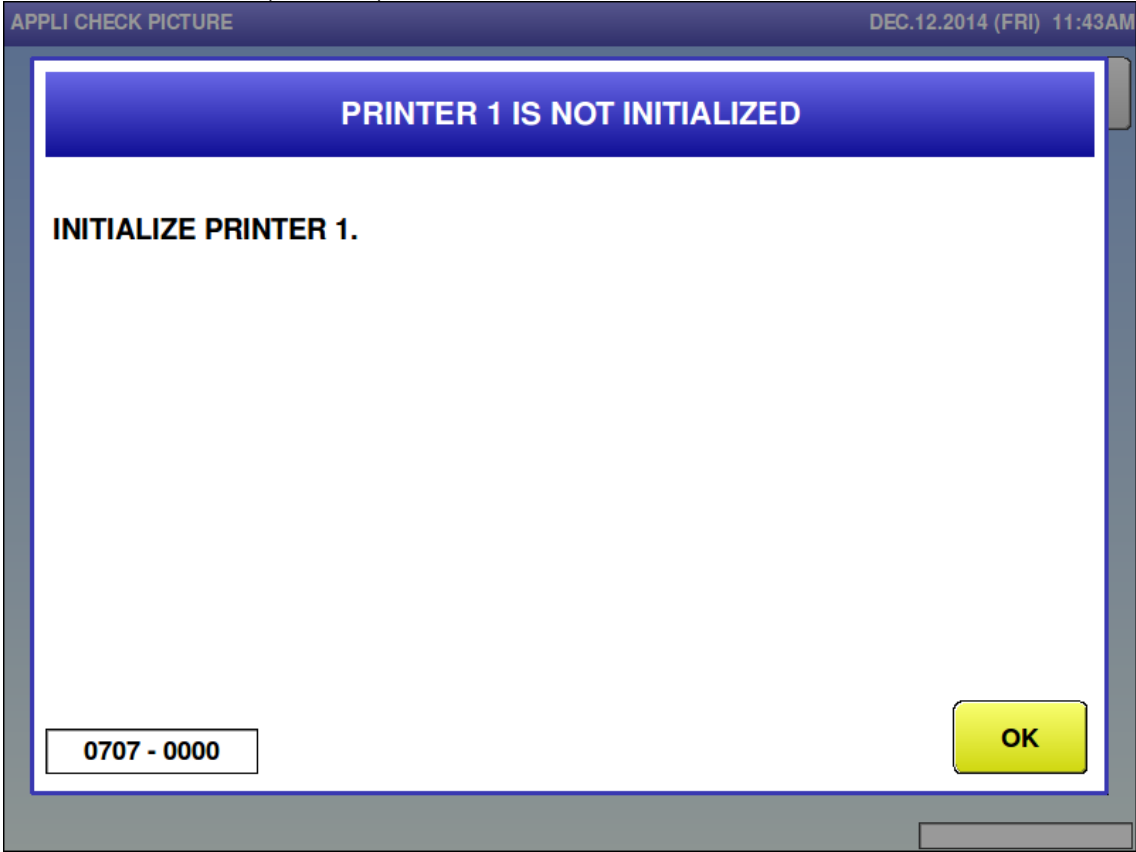

Error content	The printer is not initialized.
Detail	Incomplete printer initialization.
Solution	[OK] button
Action by user	
Action by service representative	
Related part	
Remarks	<ul style="list-style-type: none"> ▪ “Printer No.1” changes depending on error No. ▪ Printer unit memory needs to be initialized on the [ADJUST (PRINTER)] screen.

■ No label for printer1 (710-0001, 810-0001)

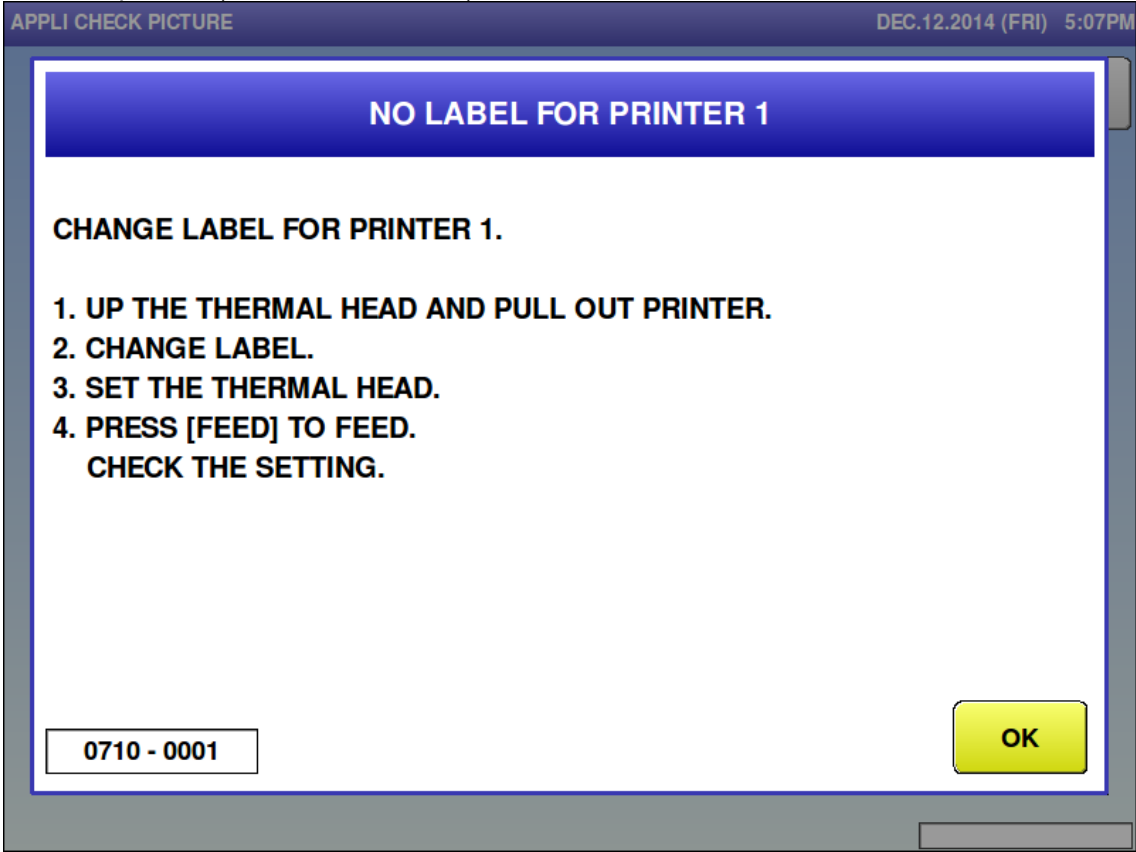

Error content	Printer label finished.
Detail	Message indicates that labeling issue is completed in DP mode.
Solution	Press the [OK] button after replacing the label, then performing unloaded feed.
Action by user	
Action by service representative	
Related part	
Remarks	"Printer No.1" changes depending on error No.

■ No label for printer1 (710-0002, 810-0002)

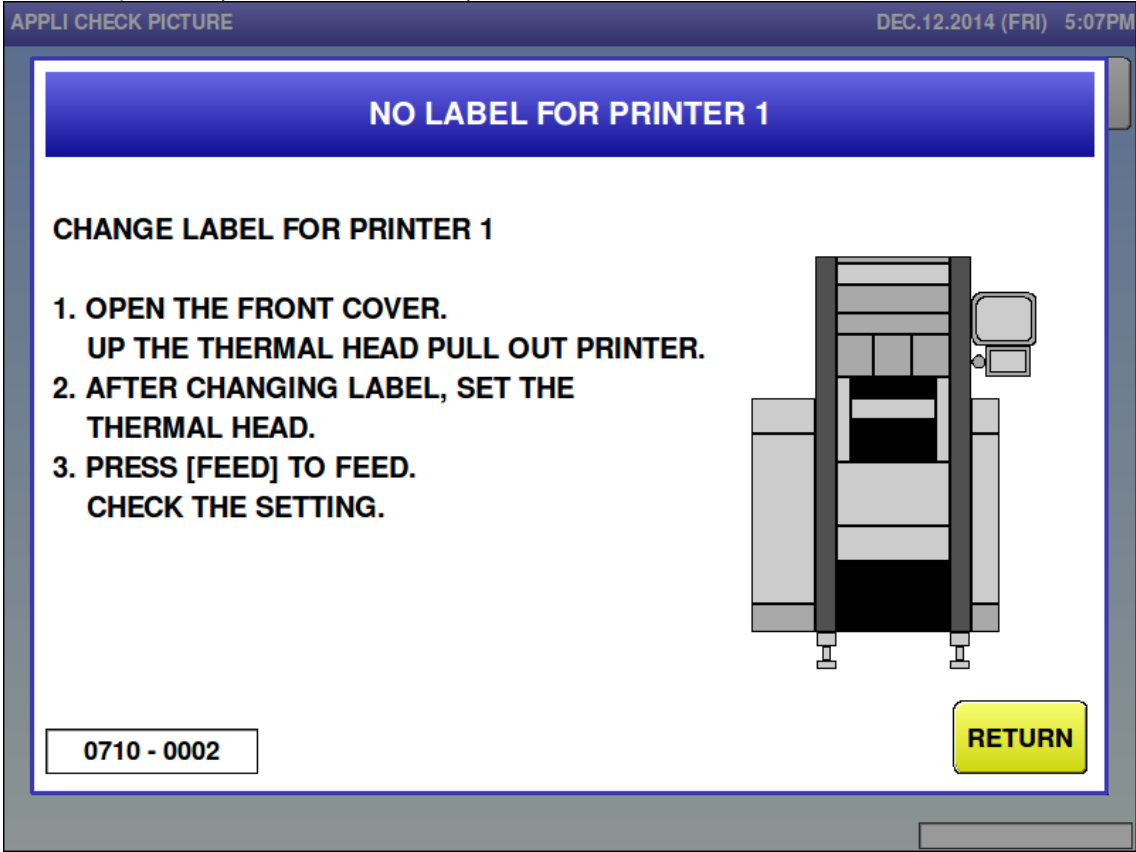

Error content	Printer label finished.
Detail	Message indicates that labeling issue is completed in DP mode, and closing the front cover.
Solution	Replace the label by performing unloaded feed, close the front cover, then press the [RETURN] button or the [PLU] button.
Action by user	
Action by service representative	
Related part	
Remarks	"Printer No.1" changes depending on error No.

■ Label size error for printer1 (711-0001, 811-0001)

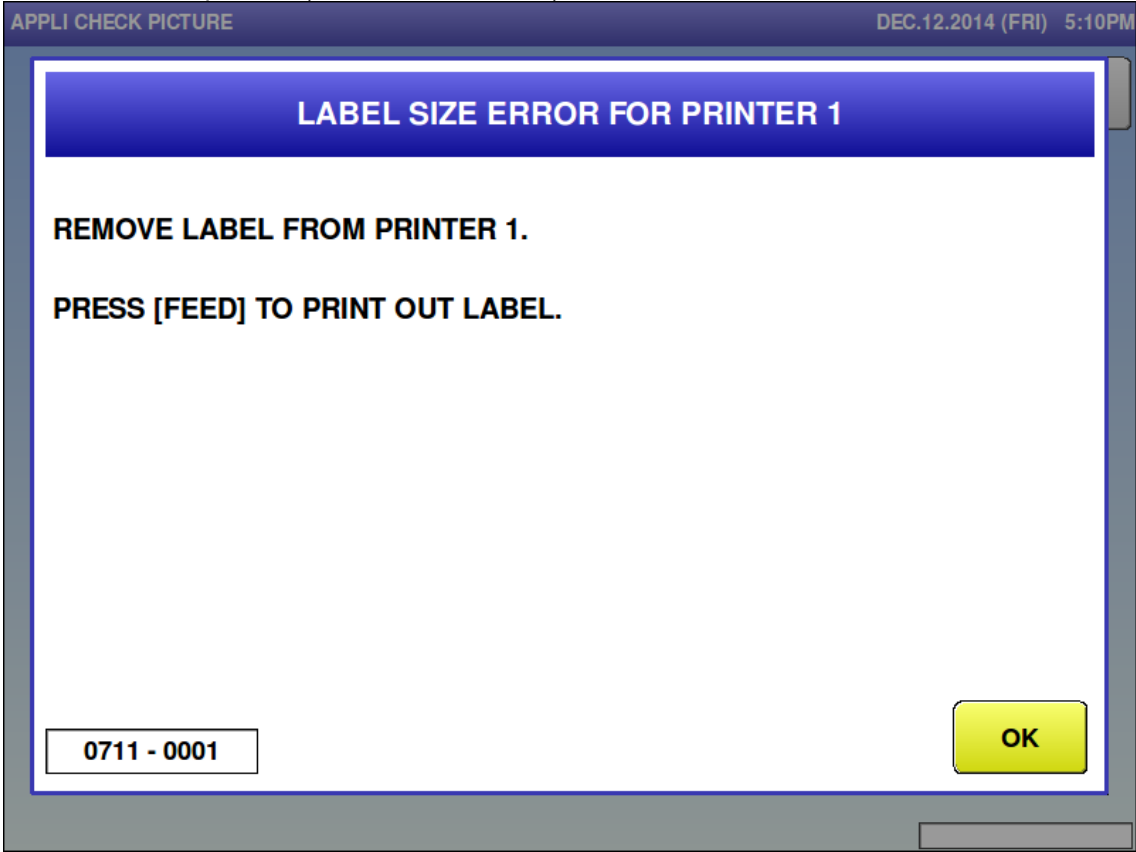

Error content	Label size error for printer1
Detail	Error indicates that the format size of producing label in DP mode is different from actual label size.
Solution	Press the [OK] button after removing label by performing the unloaded feed.
Action by user	
Action by service representative	<ul style="list-style-type: none"> - Clean the label gap sensor. - Calibrate the label gap sensor: Adjust menu > Printer > Label Feed tab. - Check for labels sticking or binding. - Measure the label and verify with the label format length. - See section 2.2.1.4 Handling Methods in Case of a Label Size Error.
Related part	
Remarks	"Printer No.1" changes depending on error No. Check the format of label to be printed.

■ Label size error for printer1 (711-0002, 811-0002)

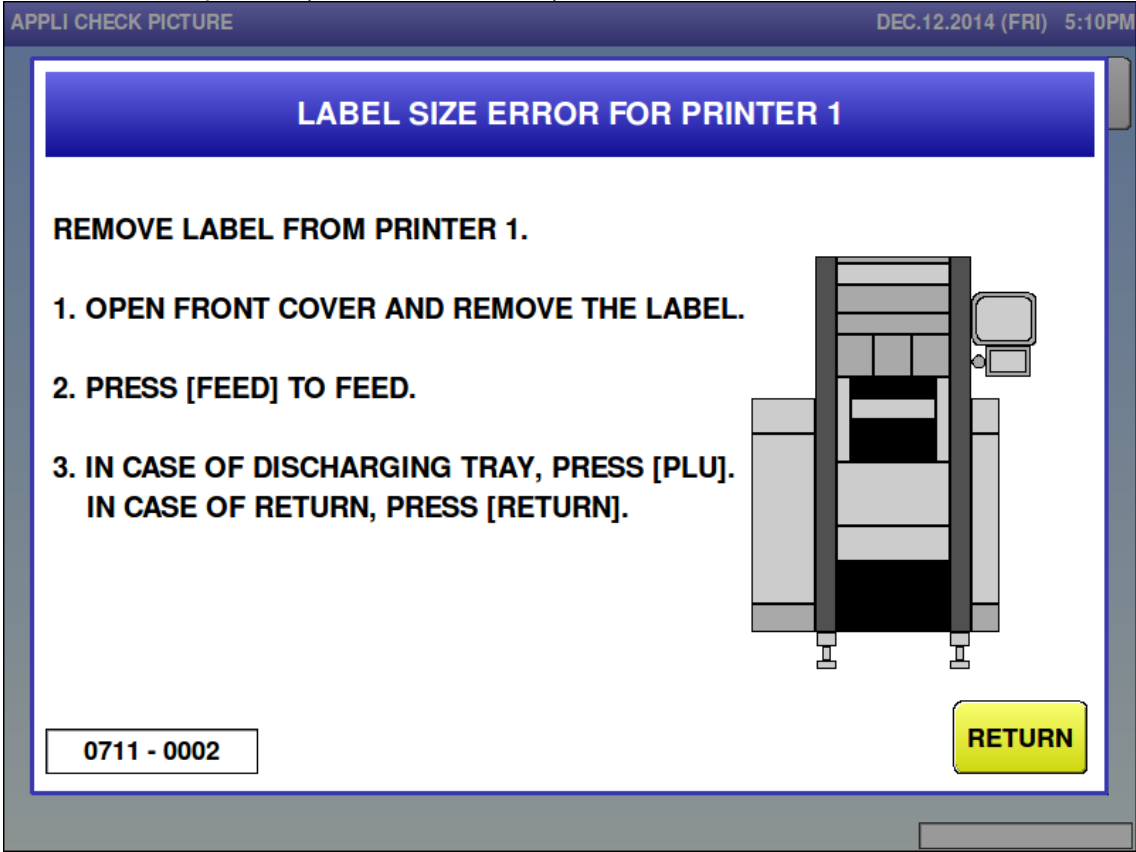

Error content	Printer label size error.
Detail	Error indicates that the format size of producing label is different from actual label size when the front cover is closed.
Solution	Remove the label by performing unloaded feed, close the front cover, then press the [RETURN] button or the [PLU] button.
Action by user	
Action by service representative	<ul style="list-style-type: none"> - Clean the label gap sensor. - Calibrate the label gap sensor: Adjust menu > Printer > Label Feed tab. - Check for labels sticking or binding. - Measure the label and verify with the label format length. - See section 2.2.1.4 Handling Methods in Case of a Label Size Error.
Related part	
Remarks	<p>“Printer No.1” changes depending on error No.</p> <p>Check the format of label to be printed.</p>

■ Too many characters on format for printer 1 (713, 813)

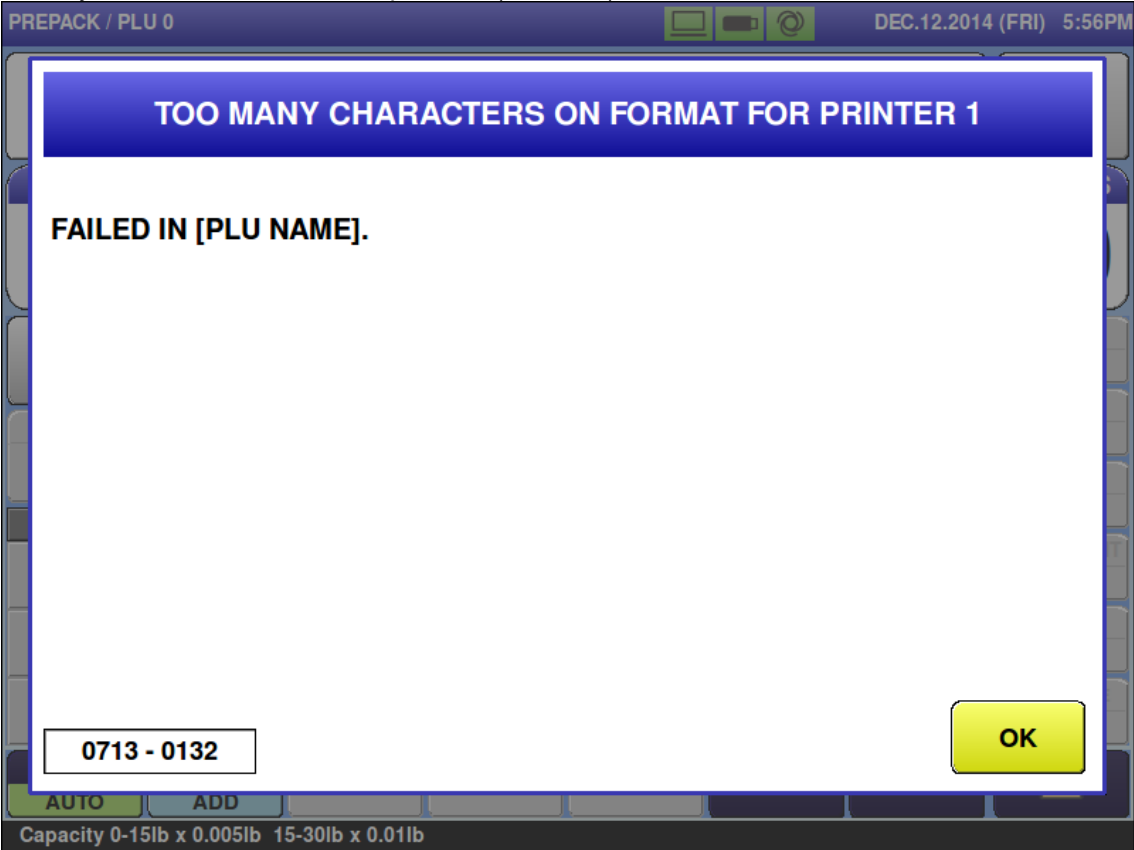

Error content	Too many characters on format for printer 1.
Detail	Expanded printing error information is added to the sub-error No.
Solution	[OK] button
Action by user	
Action by service representative	
Related part	
Remarks	<ul style="list-style-type: none"> ▪ “Printer No.1” changes depending on error No. ▪ Expanded printing error information is displayed. ▪ 0713-0132. This also occurs if there are two or more Product Name fields in the label format and no description prints -- even if one of the fields is large enough.

- Thermal head is worn out for printer 1 (715-0001, 815-0001)

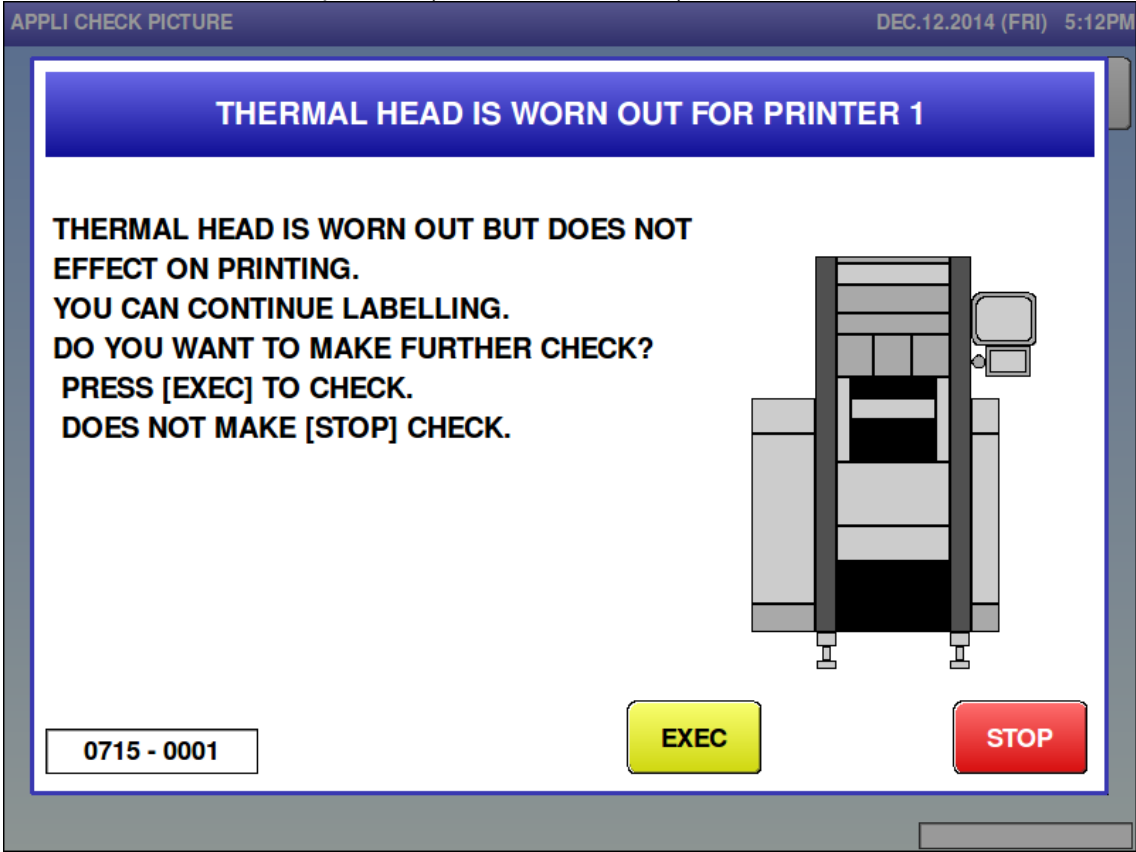

Error content	Thermal head is worn out for printer 1.
Detail	Affected content is separated by sub-error No. 0001: The portion that as run out has no effect on printing.
Solution	[EXEC] button, [STOP] button [EXEC]: Head check is performed to the next product. [STOP]: Head check is not performed to the next product.
Action by user	
Action by service representative	
Related part	
Remarks	"Printer No.1" changes depending on error No.

- Thermal head is worn out for printer 1 (715-0002, 815-0002)

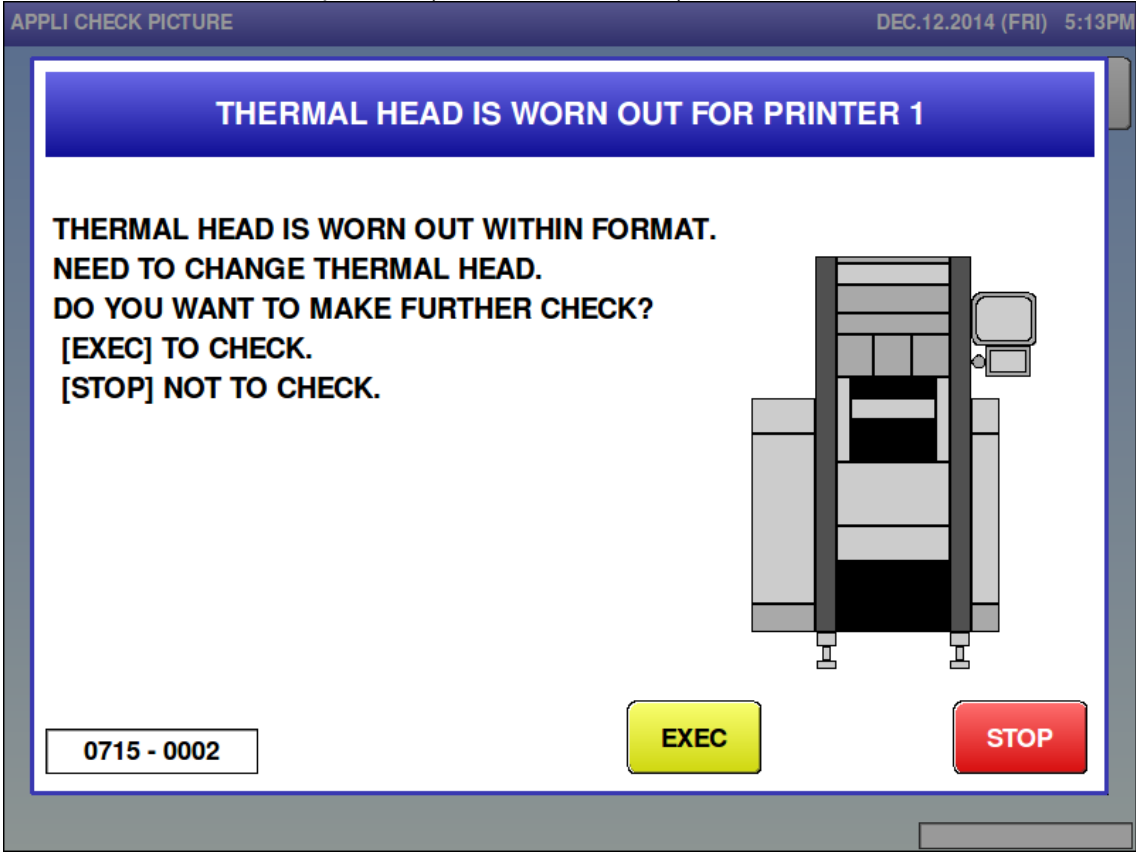

Error content	Thermal head is worn out for printer 1.
Detail	Affected portion is separated by sub-error No. 0002: It has run out in the formatted printing area.
Solution	[EXEC] button, [STOP] button [EXEC]: Head check is performed to the next product. [STOP]: Head check is not performed to the next product.
Action by user	
Action by service representative	
Related part	
Remarks	"Printer No.1" changes depending on error No.

- Thermal head is worn out for printer 1 (715-0003, 815-0003)

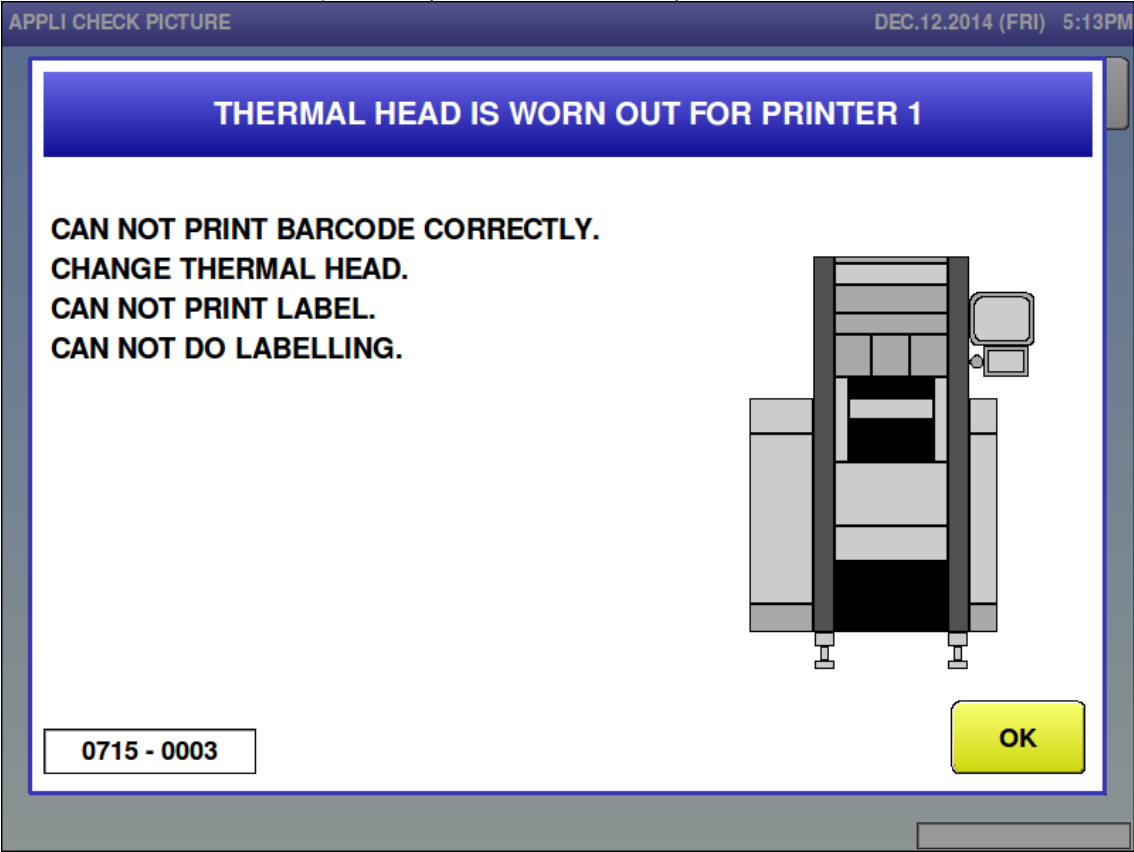

Error content	Thermal head is worn out for printer 1.
Detail	Affected portion is separated by sub-error No. 0003: The barcode portion has run out.
Solution	[OK] button
Action by user	
Action by service representative	
Related part	
Remarks	"Printer No.1" changes depending on error No.

■ Thermal head for printer 1 up (716-0001, 816-0001)

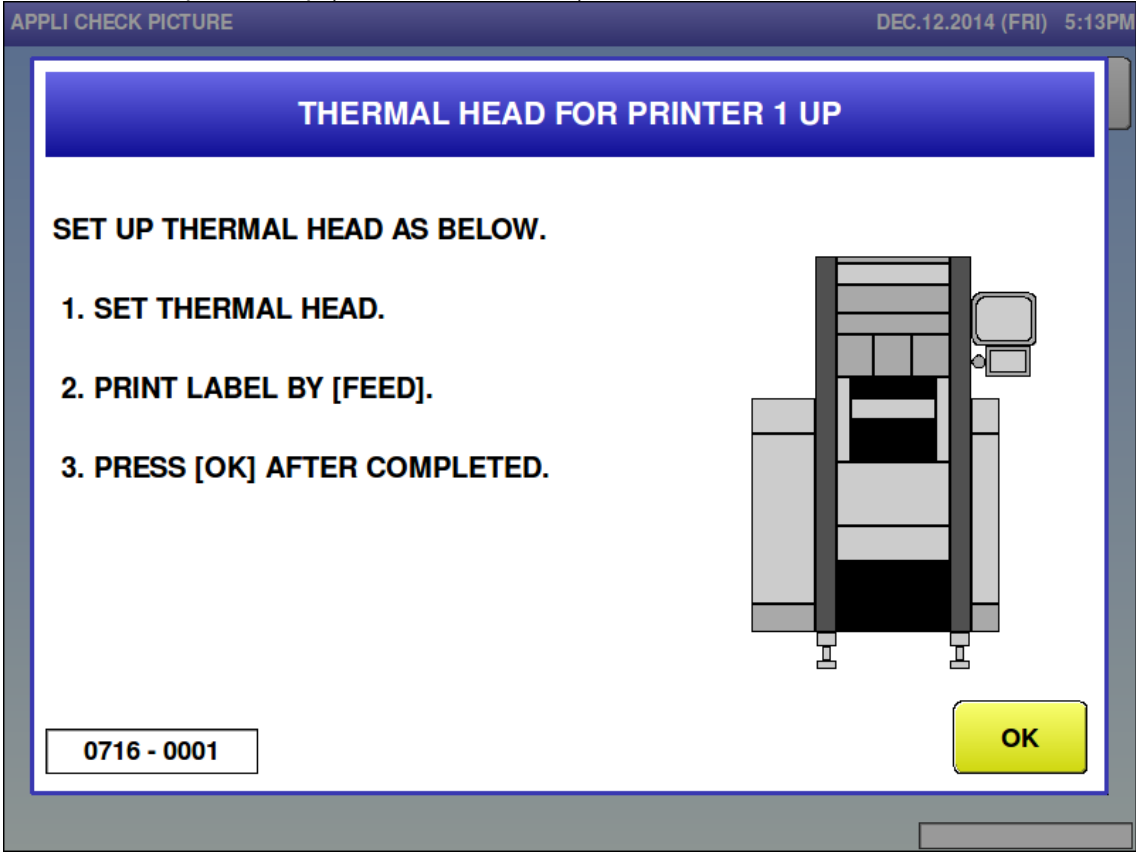

Error content	Thermal head for printer 1 up.
Detail	The thermal head was up when printing starts. *This error is displayed in DP mode.
Solution	Press the [OK] button after setting the thermal head.
Action by user	
Action by service representative	
Related part	
Remarks	"Printer No.1" changes depending on error No.

■ Thermal head for printer 1 up (716-0002, 816-0002)

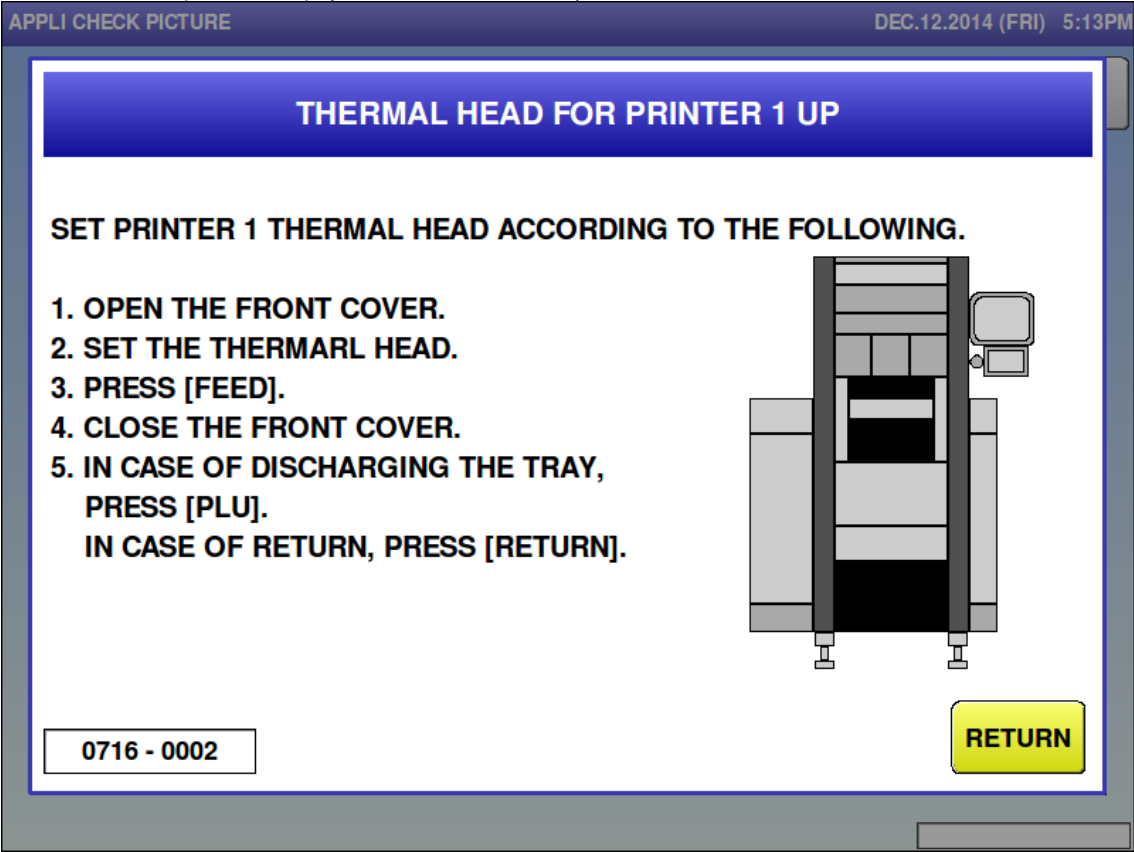

Error content	Thermal head for printer 1 up.
Detail	The thermal head was up when printing starts. This error is displayed when closing the front cover.
Solution	Press the [RETURN] button after setting the thermal head.
Action by user	
Action by service representative	
Related part	
Remarks	"Printer No.1" changes depending on error No.

- Control board for printer 1 is failed (717-0000, 817-0000)

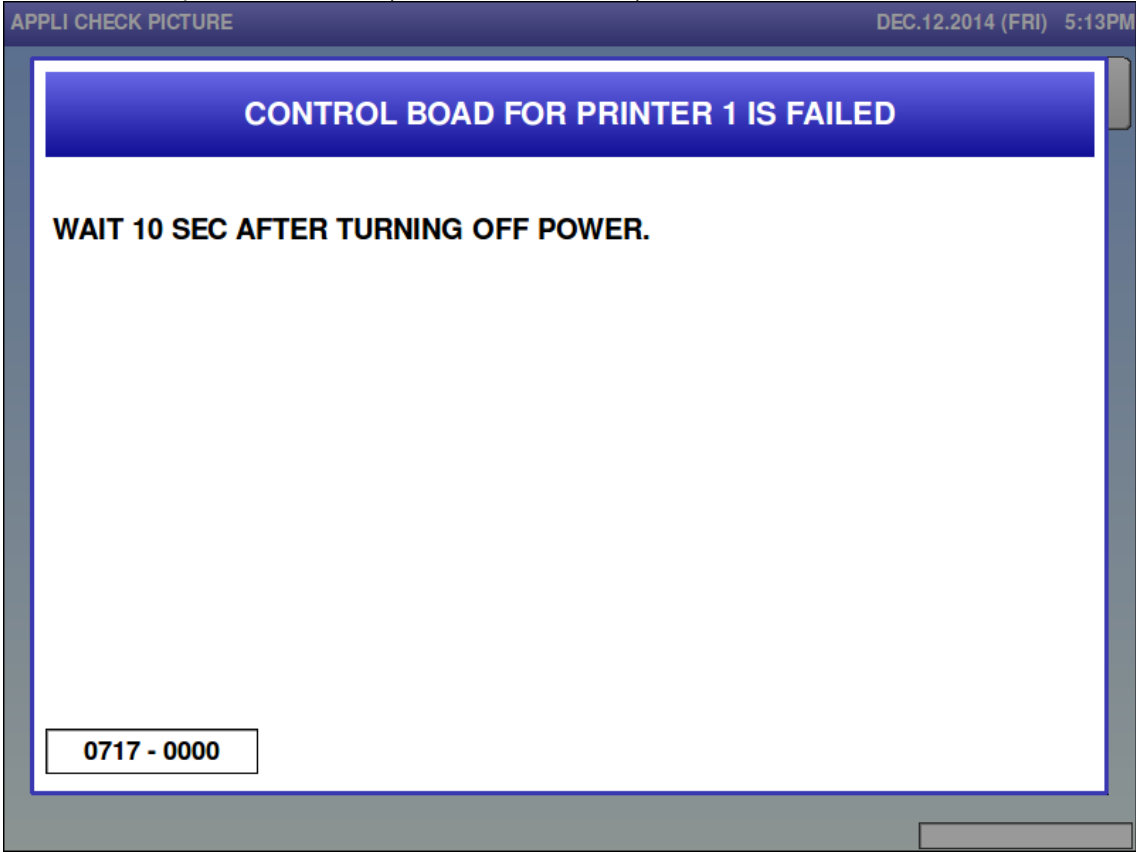

Error content	Control board for printer 1 is failed (No.1: P-1163, No.2: P-1001).
Detail	Unable to detect an interrupt signal from the printer control board (P-1163, P-1001).
Solution	Restore power
Action by user	
Action by service representative	
Related part	
Remarks	"Printer No.1" changes depending on error No.

6.3.7 Detector-related Error (No. 1500s)

- No response from tray detector (1502)

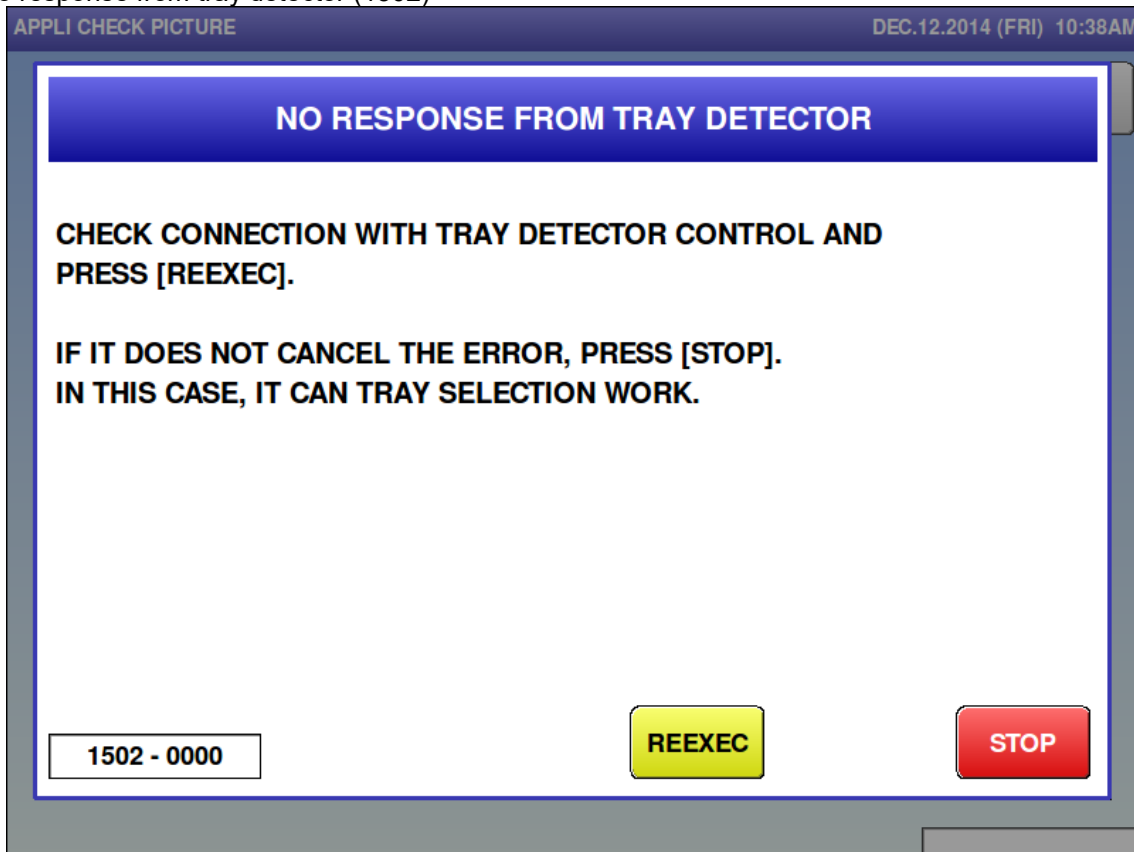

Error content	No response from tray detector.
Detail	Unable to communicate between the console and the tray detector. The communication phase number is in the sub-error. Errors after power ON process completion result in this error.
Solution	[STOP] button => Cut communication with the detector. Operate without the detector. [REEXEC] button => Check connection with the detector. If connection can be confirmed, the error is cleared.
Action by user	
Action by service representative	Confirm the RS485 communication line of the main board (P-1100, P-1163, P-1000). Confirm RS485 communication line [A221 XJ-11] and 24VDC power supply [A221 XJ-9] of the detector board.
Related part	Main board (P-1100, P-1163, P-1000) [A10] Detector board (P-1107) [A221]
Remarks	

■ Problem on tray detector (1503)

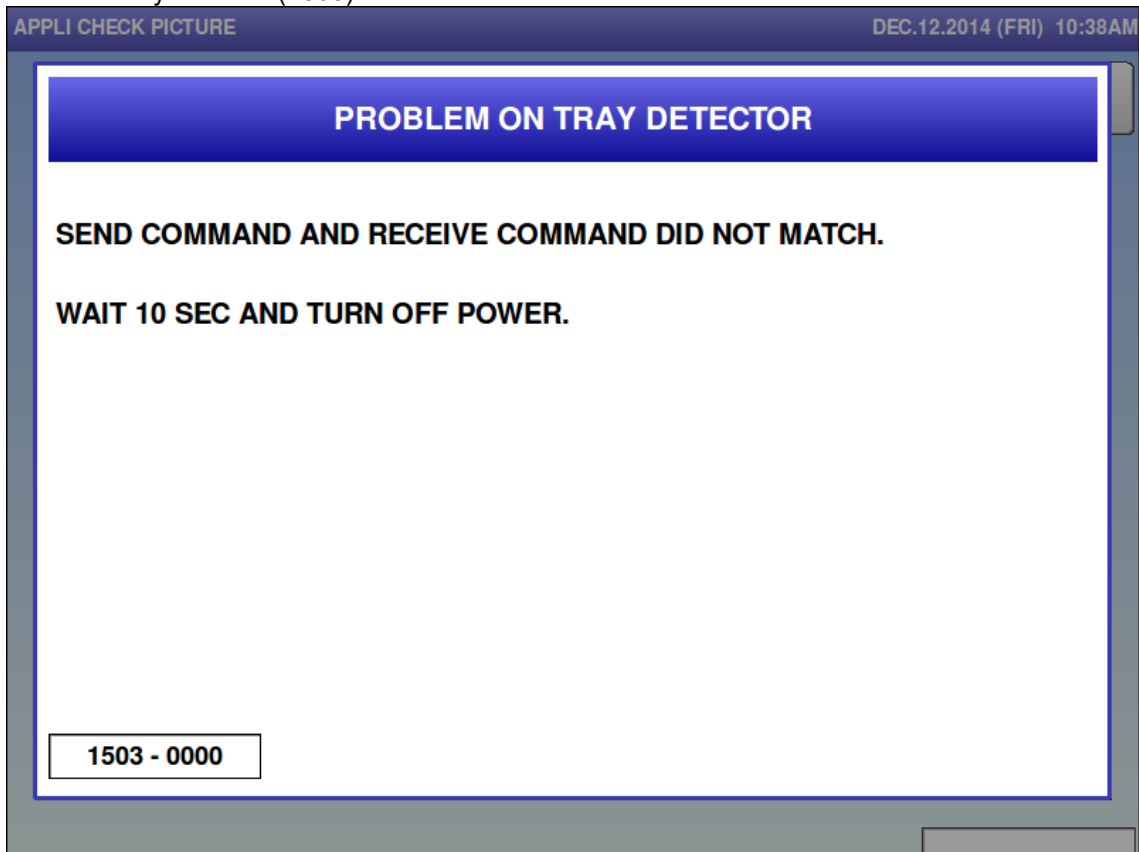

Error content	The command sent to the applicator and the command contained in the answer is different.
Detail	
Solution	Restore power
Action by user	
Action by service representative	Confirm the RS485 communication line of the main board (P-1100, P-1163, P-1000). Confirm RS485 communication line [A221 XJ-11] and 24 V DC power supply [A221 XJ-9] of the detector board.
Related part	Main board (P-1100, P-1163, P-1000) [A10] Detector board (P-1107) [A221]
Remarks	

■ Blackout for the power (1504)

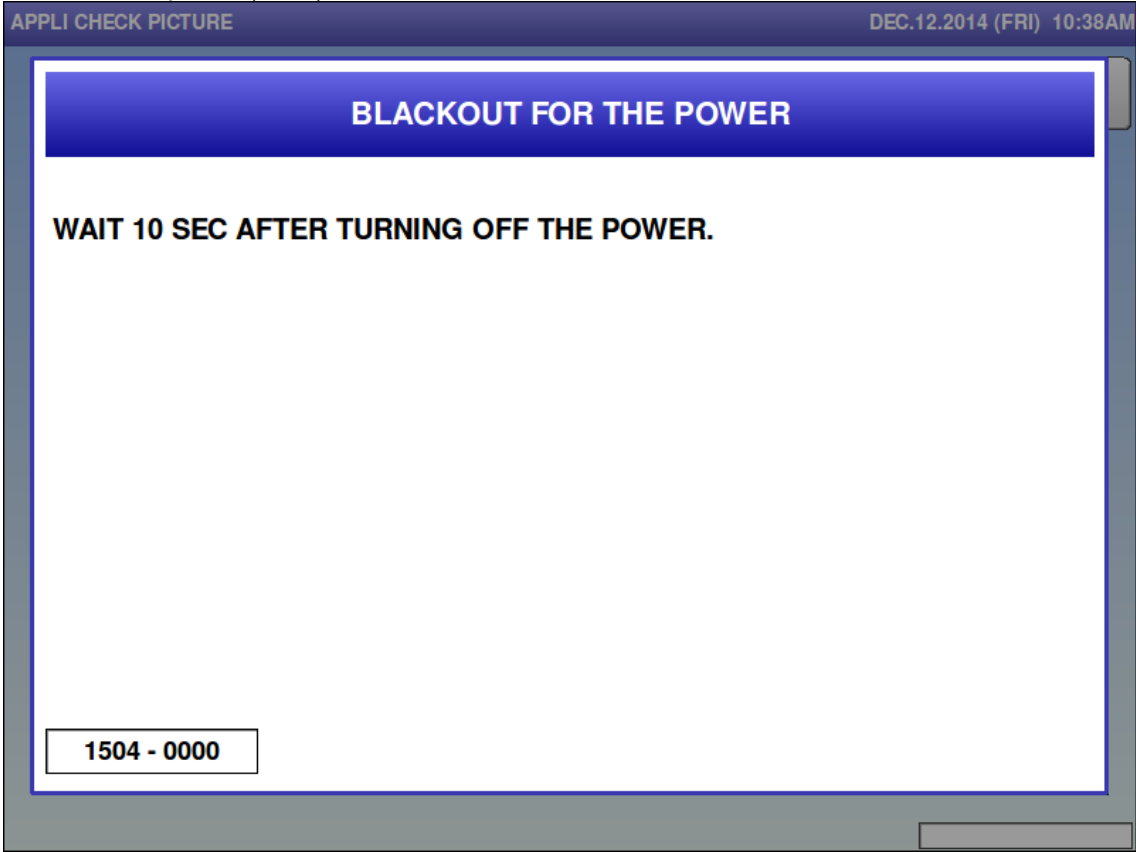

Error content	Tray detector detected power OFF in the console.
Detail	Power ON command received twice from the console.
Solution	Restore power
Action by user	
Action by service representative	Confirm the power supply 24 V DC of the main board (P-1100, P-1163, P-1000). RS485 communication line of the main board [A221 XJ-11].
Related part	Switching power supply [U10] Main board (P-1100, P-1163, P-1000) [A10] Detector board (P-1107) [A221]
Remarks	

- Tray detector detected blackout (1505)

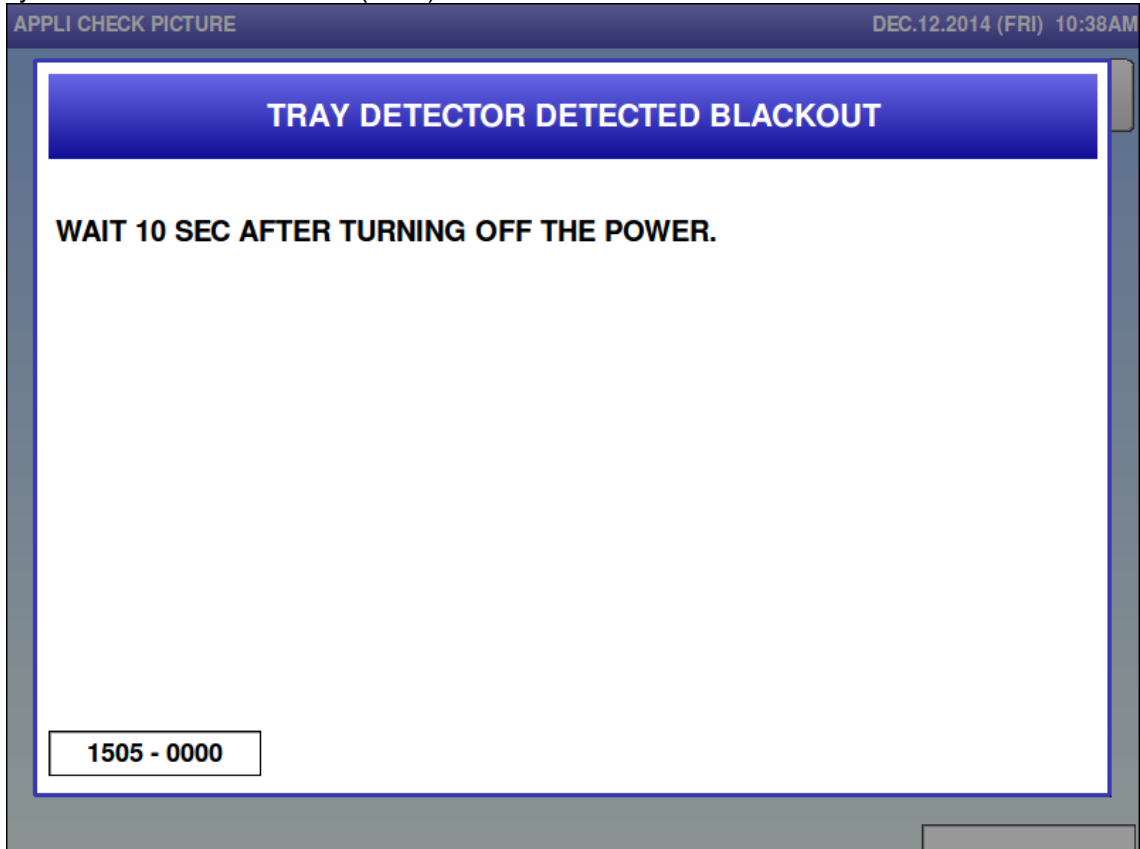

Error content	Tray detector blackout or the tray detector board CPU was reset.
Detail	A different command was received before the power ON communication command.
Solution	Restore power
Action by user	
Action by service representative	Confirm RS485 communication line [A221 XJ-11] and 24 V DC power supply [A221 XJ-9] of the detector board.
Related part	Switching power supply [U11] Main board (P-1100, P-1163, P-1000) [A10] Detector board (P-1107) [A221]
Remarks	

■ Cannot connect with camera unit (1506)

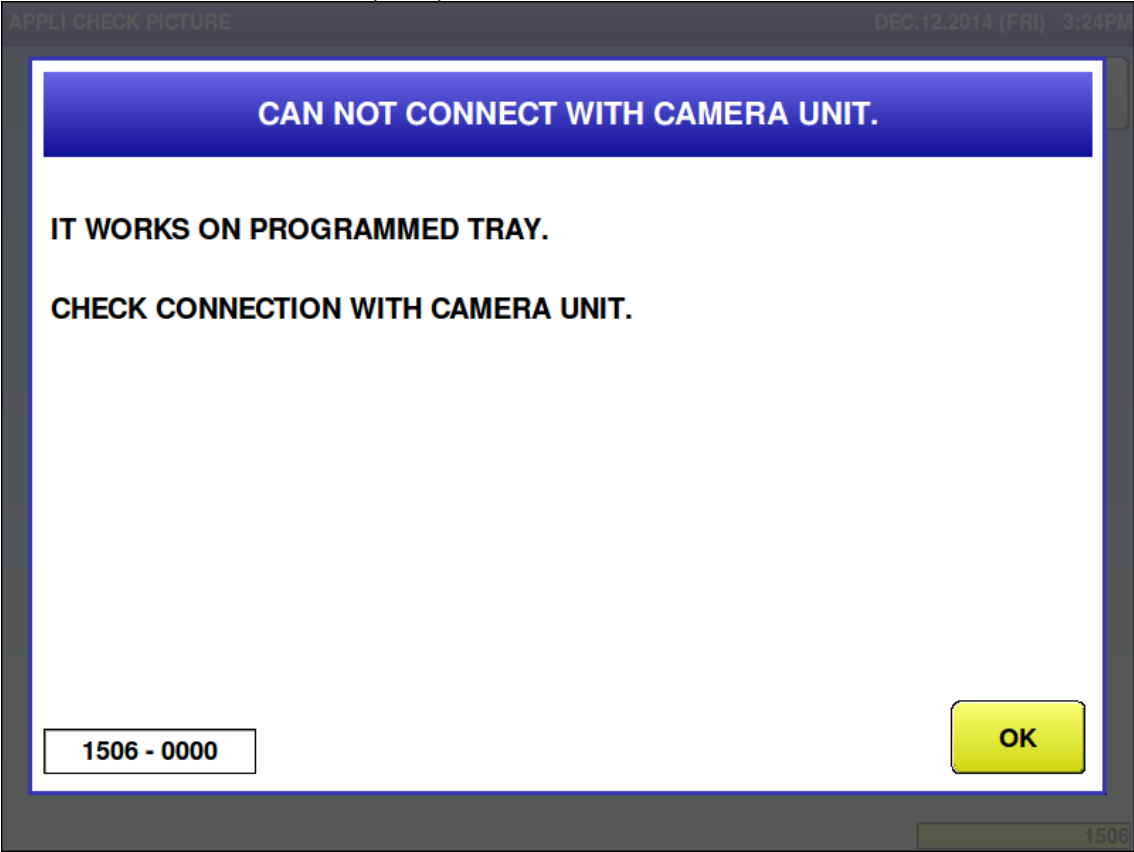

Error content	Unable to communicate between tray detector and the tray detector camera.
Detail	It has been decided that the camera is not connected due to the inability to obtain a proper response when attempting to set the camera.
Solution	[OK] button => Operate without the tray detector. (Operate with registered trays.)
Action by user	
Action by service representative	Confirm the connection between the detector board and CMOS camera [A221 XJ-4].
Related part	Detector board (P-1107) [A221] CMOS camera
Remarks	

■ Problem on tray detector (1507)

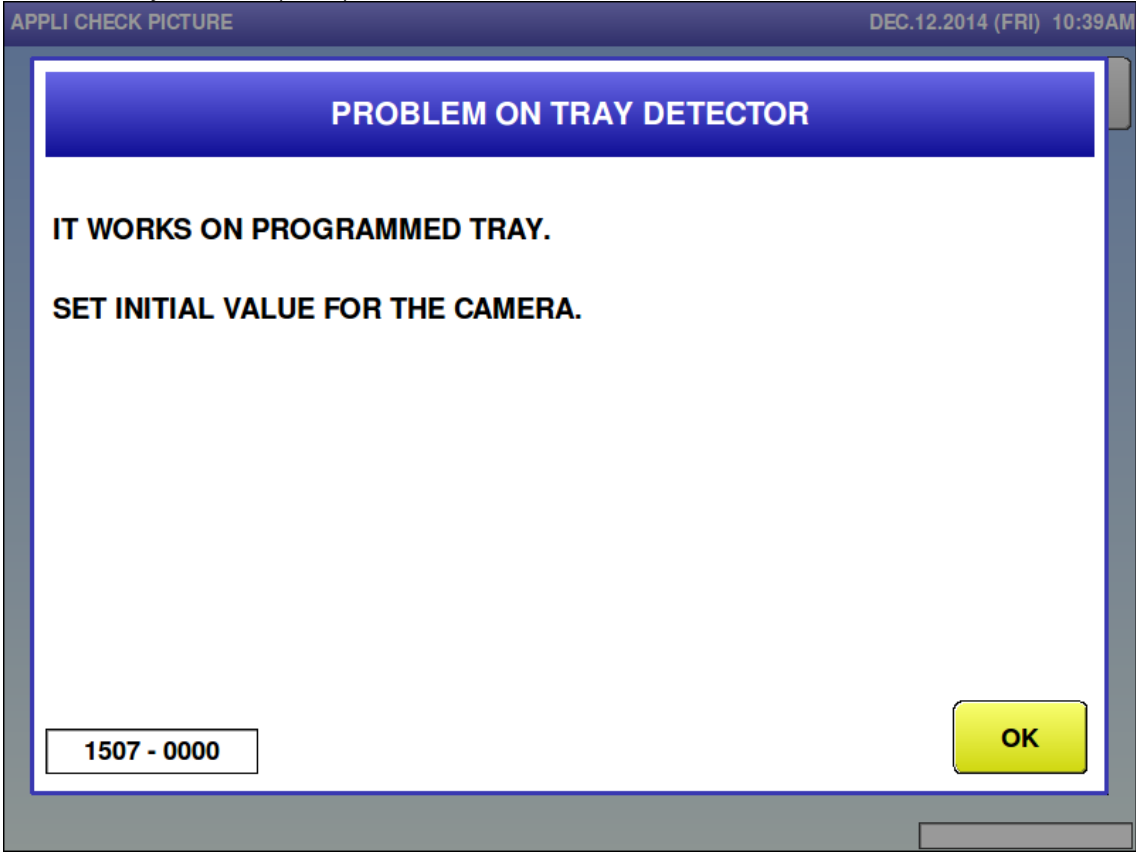

Error content	Threshold has not been set
Detail	An error occurred when writing threshold to FROM.
Solution	[OK] button => Operate without the tray detector. (Operate with registered trays.)
Action by user	
Action by service representative	
Related part	Detector board [A221]
Remarks	

■ Sum value for receiving is abnormal (1530)

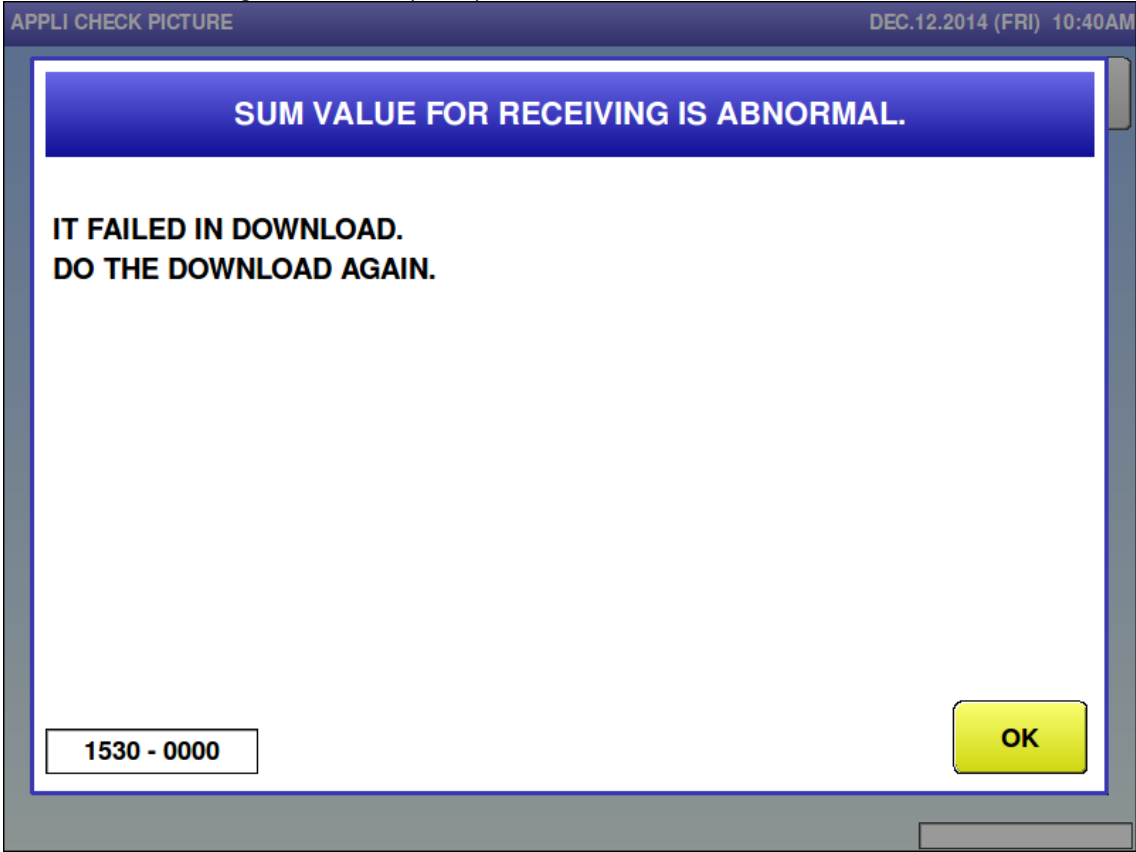

Error content	Data sum value error when downloading the program
Detail	Occurs if error exists of program data received from detector board when downloading the detection application program. Communication was not achieved between the main board and detector board due to noise when downloading.
Solution	[OK] button
Action by user	
Action by service representative	Perform re-download of the detector application.
Related part	Main board (P-1100, P-1163, P-1000) [A10] Detector board (P-1107) [A221]
Remarks	

■ Writing for flash ROM is busy (1531)

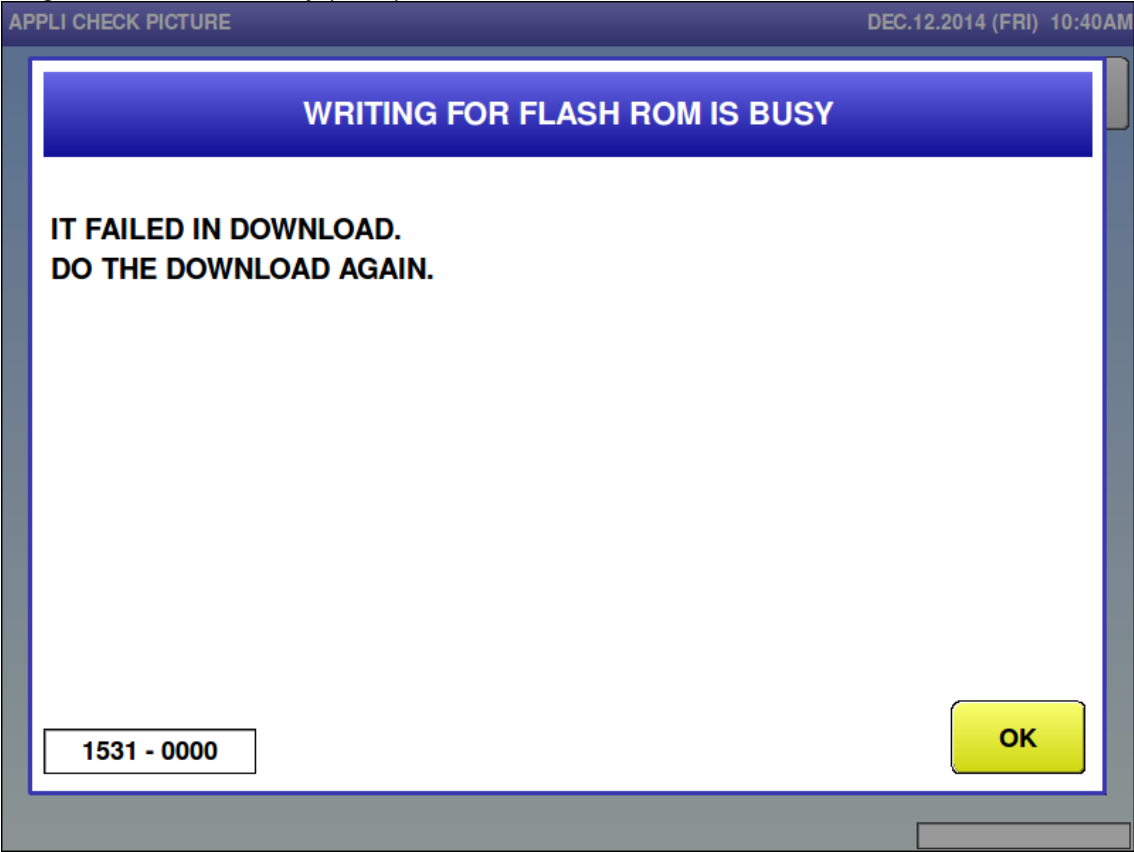

Error content	Unable to complete transit from detector flash ROM write during program download.
Detail	
Solution	[OK] button
Action by user	
Action by service representative	Perform re-download of the detector application.
Related part	Detector board (P-1107) [A221]
Remarks	

■ Failed in writing in flash ROM (1532)

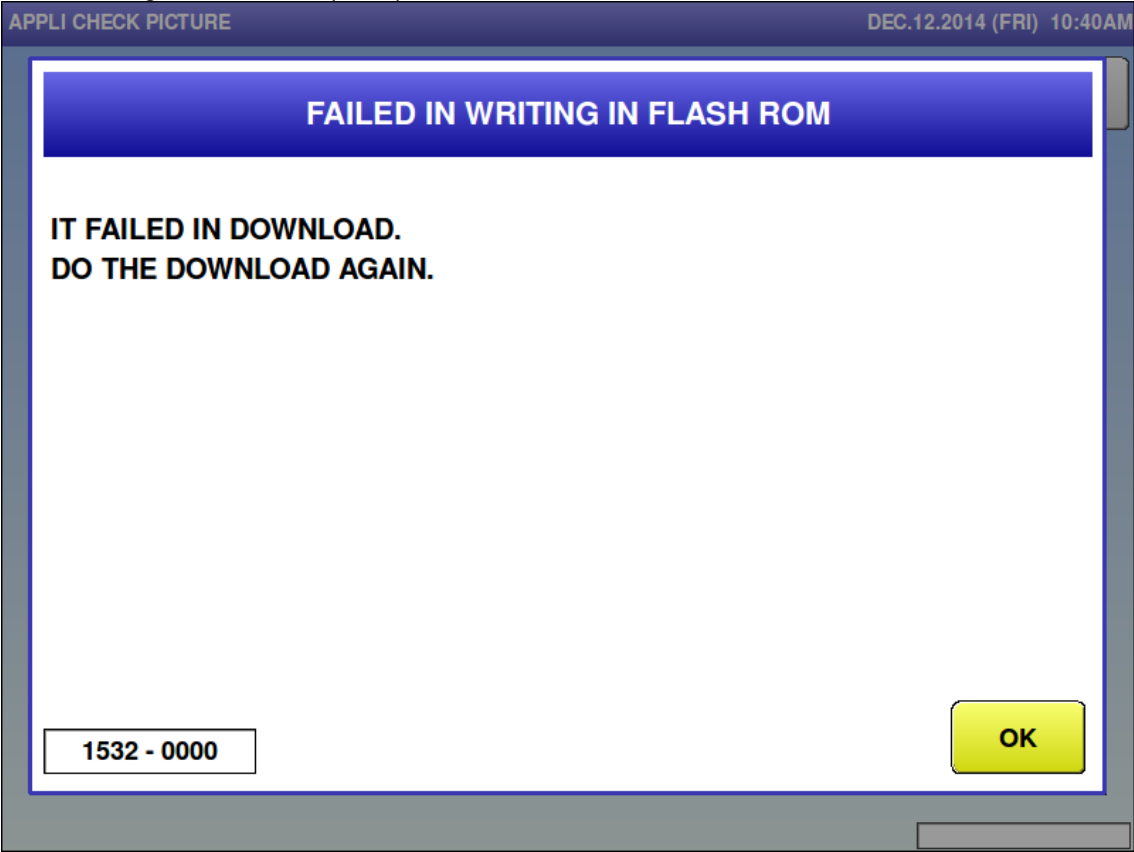

Error content	Detector failed to write flash ROM data during download.
Detail	
Solution	[OK] button
Action by user	
Action by service representative	Perform re-download of the detector application.
Related part	Detector board (P-1107) [A221]
Remarks	

■ Problem on tray detector (1533)

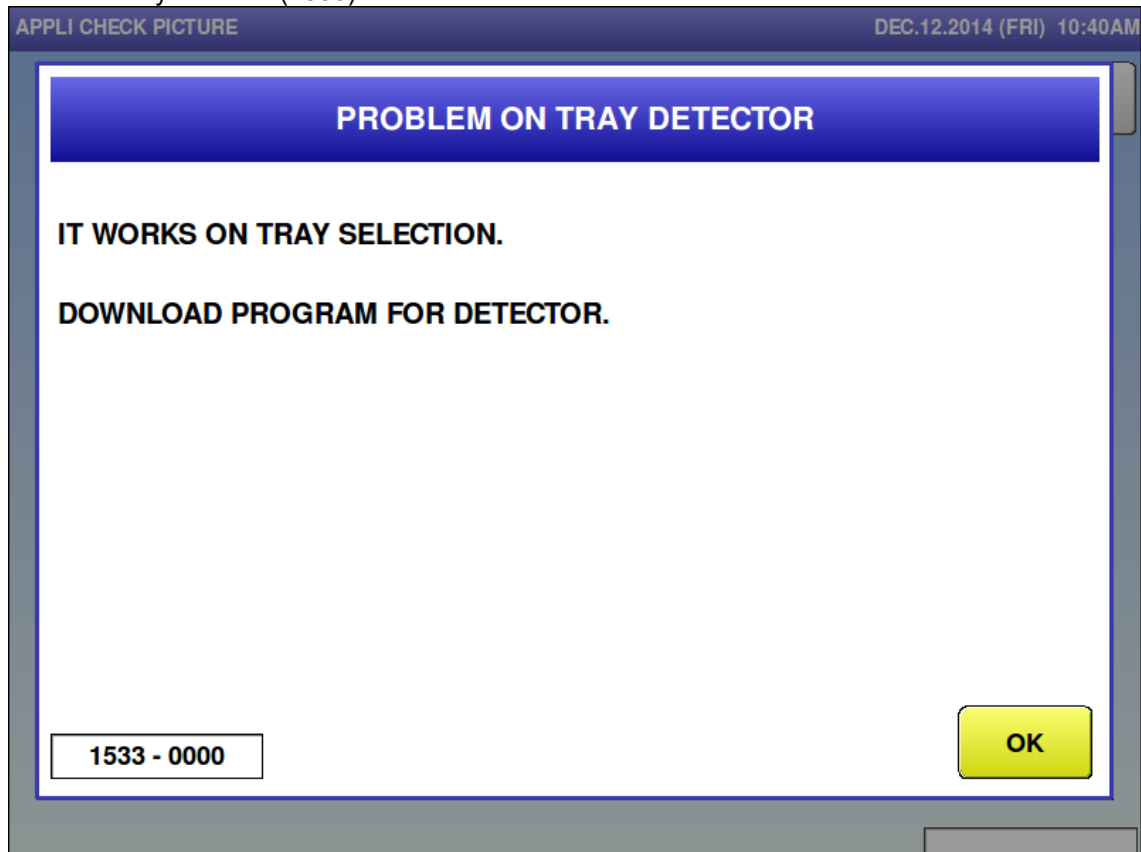

Error content	There is a boot program but no application program in the detector.
Detail	Separated by sub-error No. 0000: No application program exists. A boot program started. 0001: A boot program has started while between pin 2 and 3 of Jumper SW (JP2) in the detector board is short circuit.
Solution	[OK] button => Operate without the tray detector. (Operate with registered trays.)
Action by user	
Action by service representative	Sub-error No.: 0000 A download of the detector application is required. Sub-error No.: 0001 Perform switching by short circuiting between pin 1 and 2 for the short circuit socket between pin 2 and 3 of the jumper SW (JP2) on the detector board.
Related part	Detector board [A221]
Remarks	

- Automatic adjustment (1534)

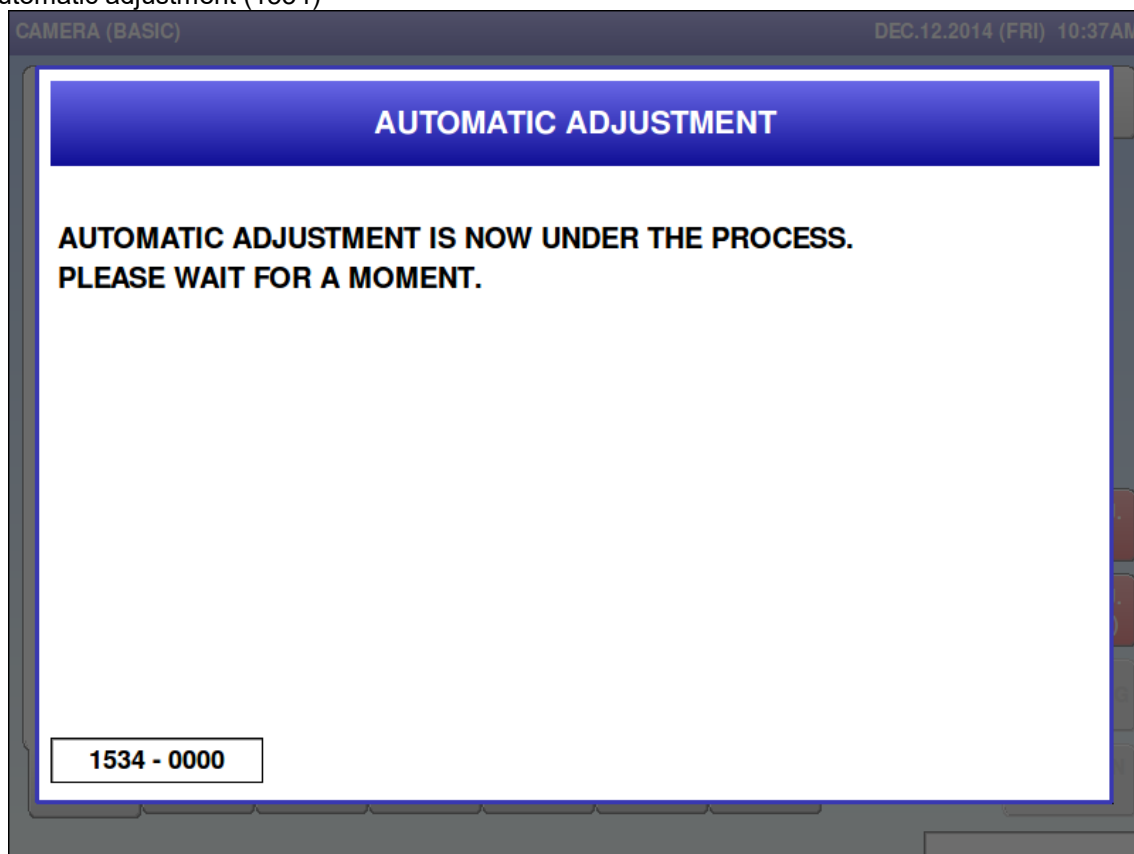

Error content	Automatic adjustment for the detector.
Detail	A screen that indicates the detector is performing the automatic adjustment (brightness, distortion, volume). After the automatic adjustment, the screen changes to error screen for No.1535 or No.1537.
Solution	
Action by user	
Action by service representative	
Related part	
Remarks	

■ Automatic adjustment is completed (1535)

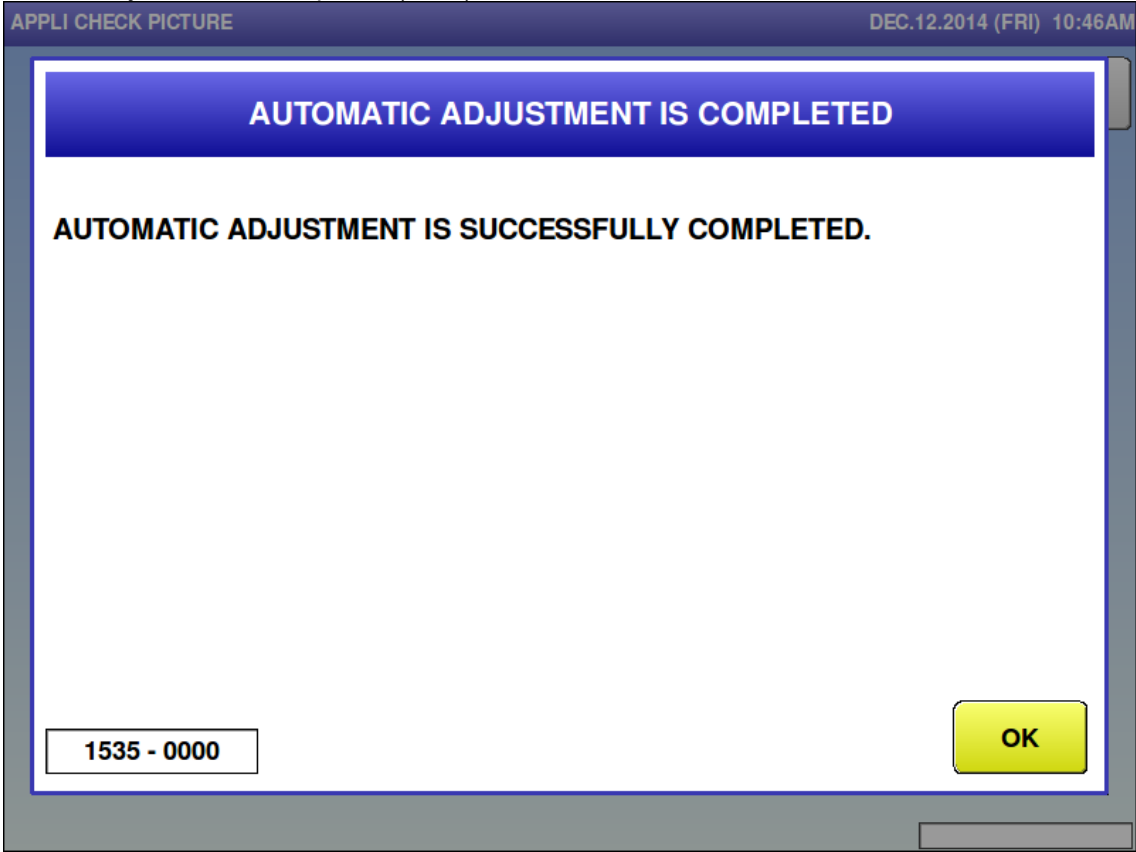

Error content	Automatic adjustment for the detector is successfully completed.
Detail	The detector successfully completed the automatic adjustment (brightness, distortion, volume).
Solution	[OK] button
Action by user	
Action by service representative	
Related part	
Remarks	

■ Automatic adjustment cannot be completed (1537)

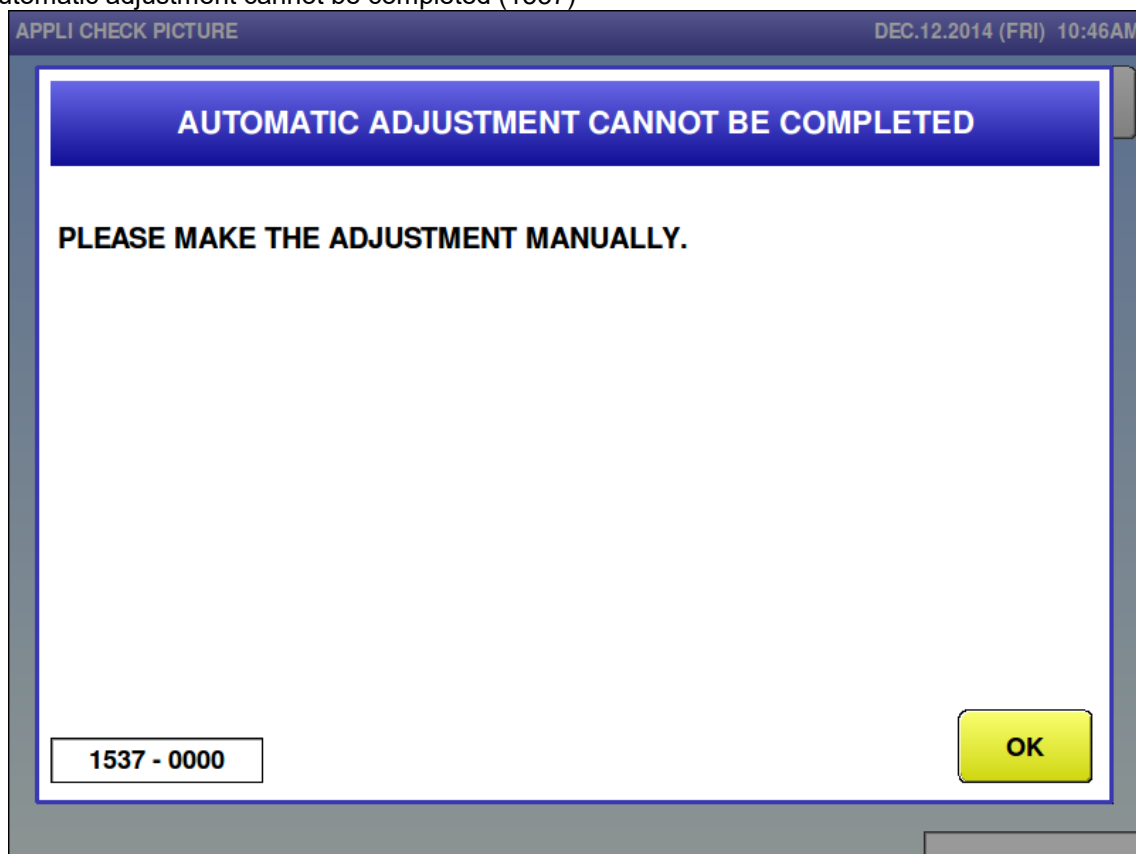

Error content	Automatic adjustment for the detector failed.
Detail	The detector could not successfully complete the automatic adjustment. Which automatic adjustment caused the error is separated by sub-error No. 0000: brightness adjustment failed 0001: distortion adjustment failed 0002: volume adjustment failed
Solution	[OK] button
Action by user	
Action by service representative	Sub-error No.: [0000] and [0001] Perform automatic adjustment of brightness and distortion after confirming the detector board and LED light for tray detection. If failed, manually perform adjustment of the detector. Sub-error No.: [0002] Perform volume height automatic adjustment after confirming the volume height sensor.
Related part	Detector board [A221] LED light for tray detection. Volume height detection sensor.
Remarks	When automatic adjustment fails, the adjustment value returns to the value before the execution.

6.3.8 Scale-related Error (No. 1600s)

- Span adjustment for scale is not completed (1601)

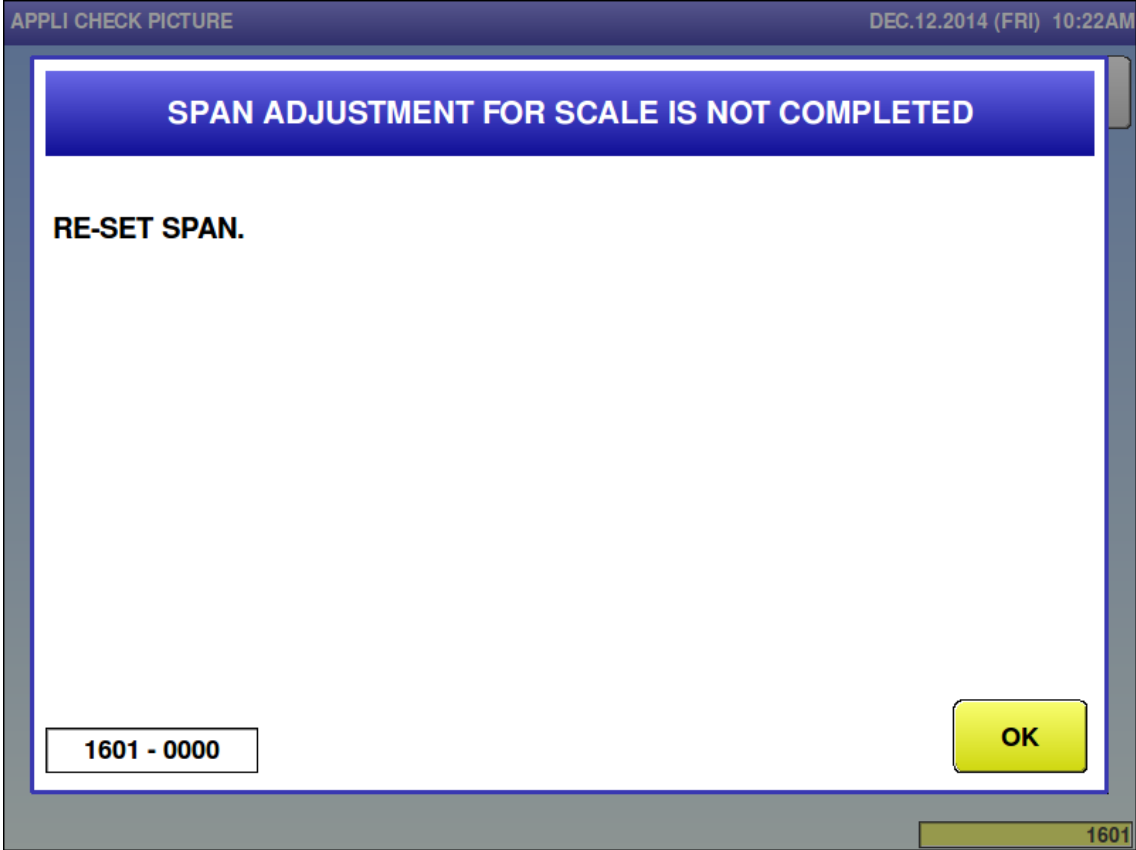

Error content	Span adjustment for scale is not completed.
Detail	The response from the scale is included in the sub-error.
Solution	[OK] button
Action by user	
Action by service representative	
Related part	
Remarks	Reset span

■ Scale initialization is not completed (1602)

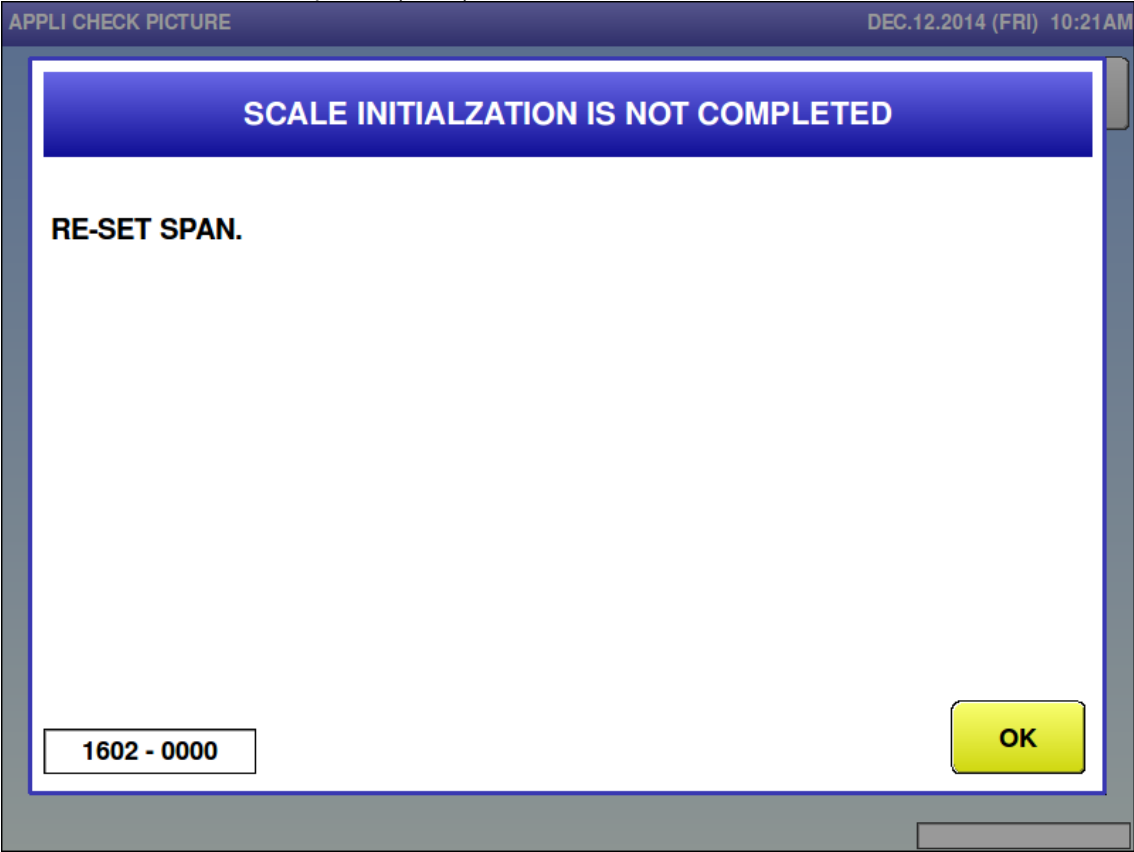

Error content	Scale initialization is not completed.
Detail	The response from the scale is included in the sub-error.
Solution	[OK] button
Action by user	
Action by service representative	
Related part	
Remarks	Reset span

■ No response from scale (1621)

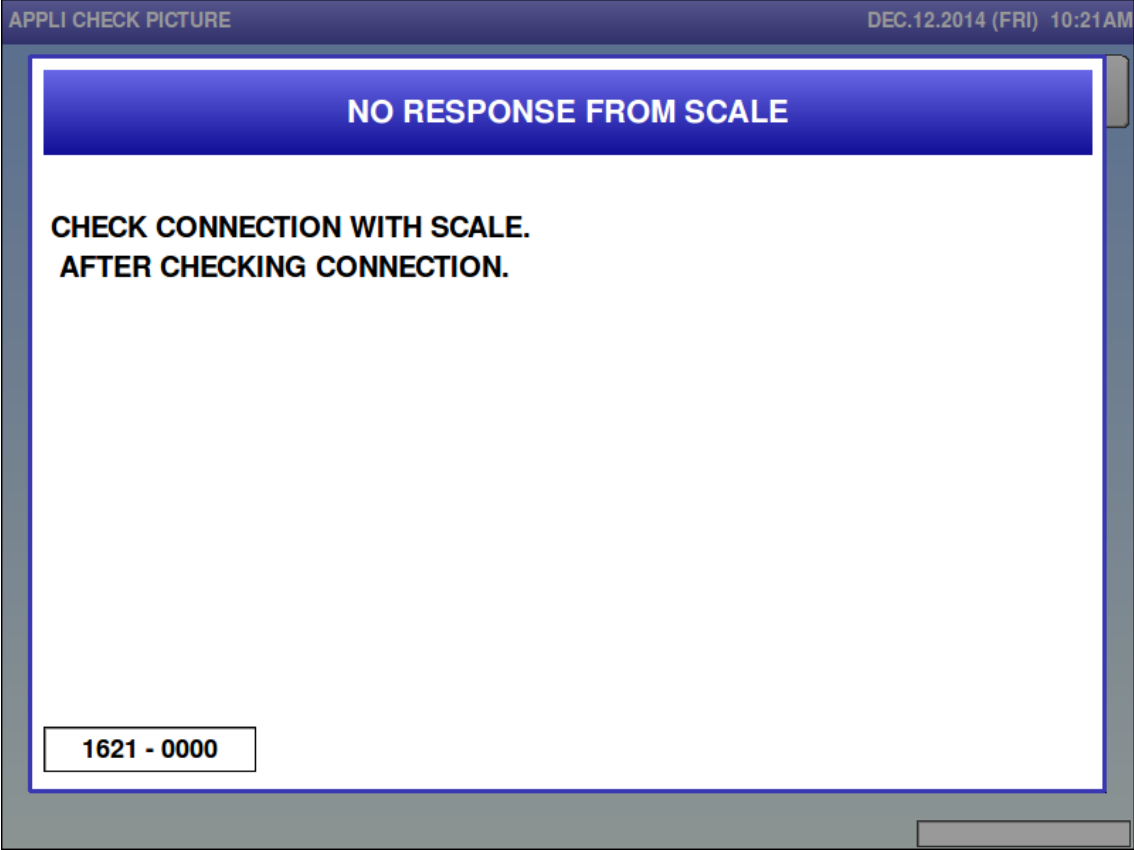

Error content	No response from scale.
Detail	
Solution	Turn off power.
Action by user	
Action by service representative	
Related part	
Remarks	Restore power after checking scale connection.

■ Cannot communicate with scale (1622)

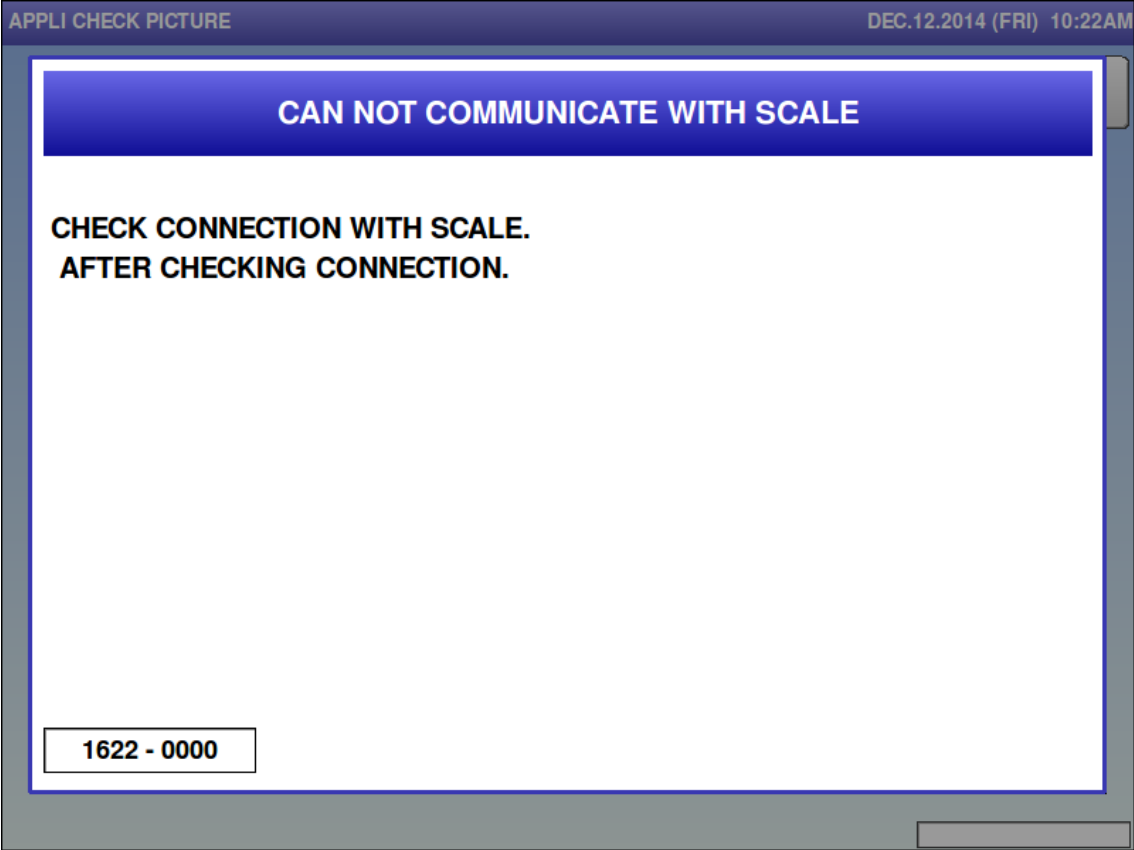

Error content	Cannot communicate with scale.
Detail	
Solution	Turn off power, [OK] button.
Action by user	
Action by service representative	
Related part	
Remarks	Restore power after checking scale connection.

6.3.9 Dialog Selection-related Error (No. 1800s, 4200s)

- Checking clock setting (1801)

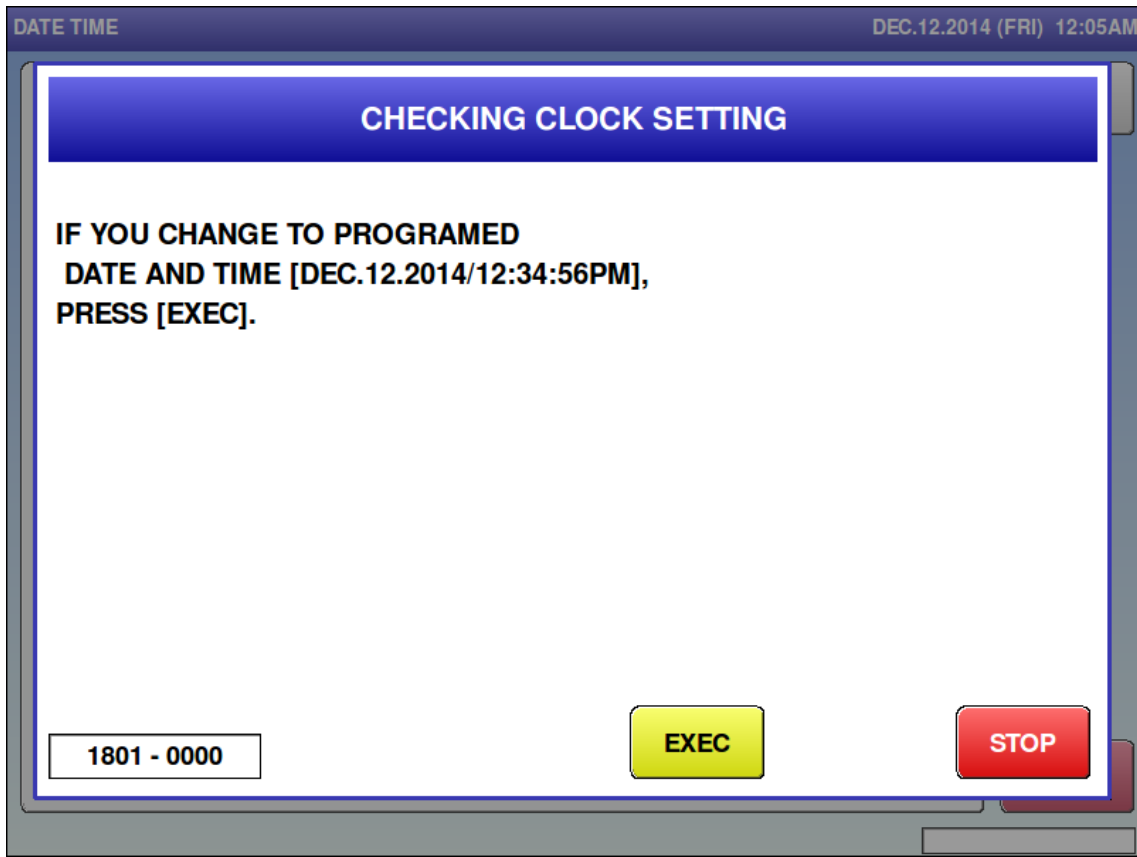

Error content	Occurs when attempting to change the clock setting.
Detail	
Solution	[EXEC] button, [STOP] button
Action by user	
Action by service representative	
Related part	
Remarks	By pressing the [EXEC] button, the clock setting is changed according to what you entered, and returns to the [MENU] screen. By pressing the [STOP] button, current clock setting is not being changed, and returns to the [MENU] screen.

■ Firmware update (1840)

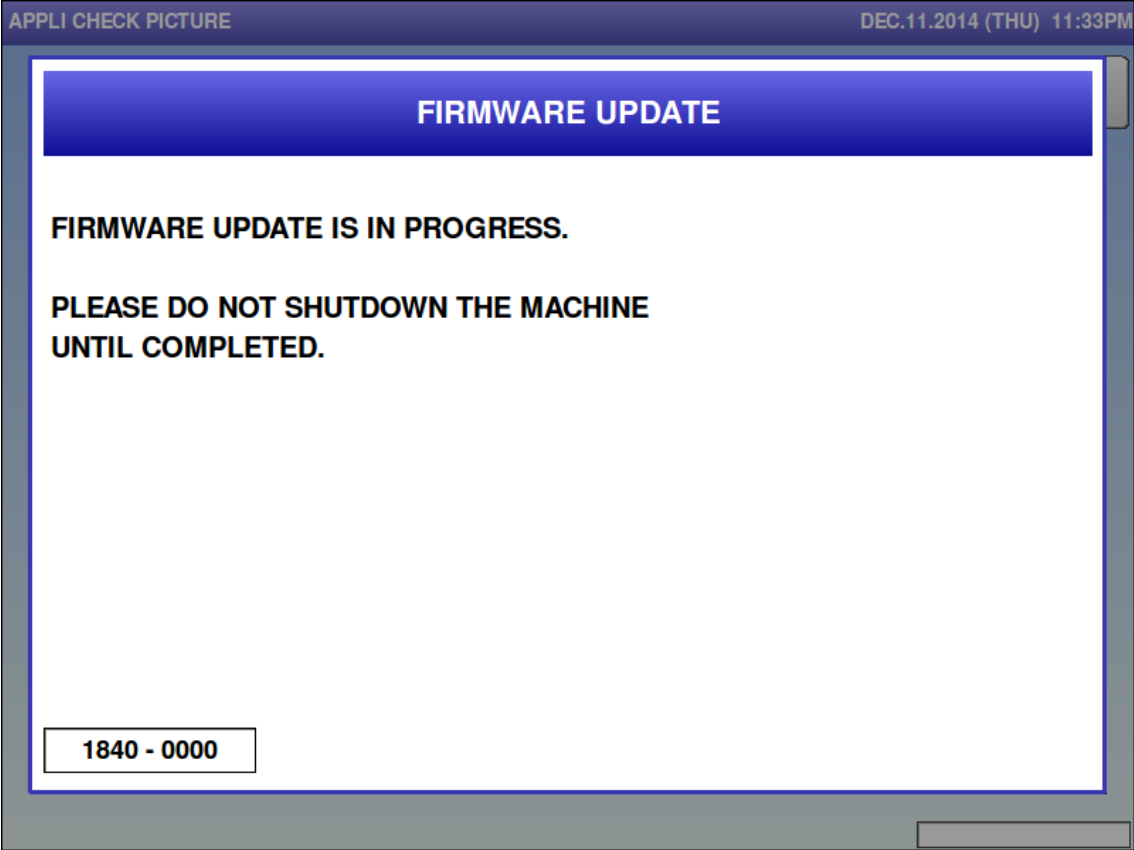

Error content	Updating the program.
Detail	Updating the program. Do not turn OFF the power.
Solution	
Action by user	
Action by service representative	
Related part	
Remarks	Display when the program is updated from SLP.

■ Firmware update is completed (1841)

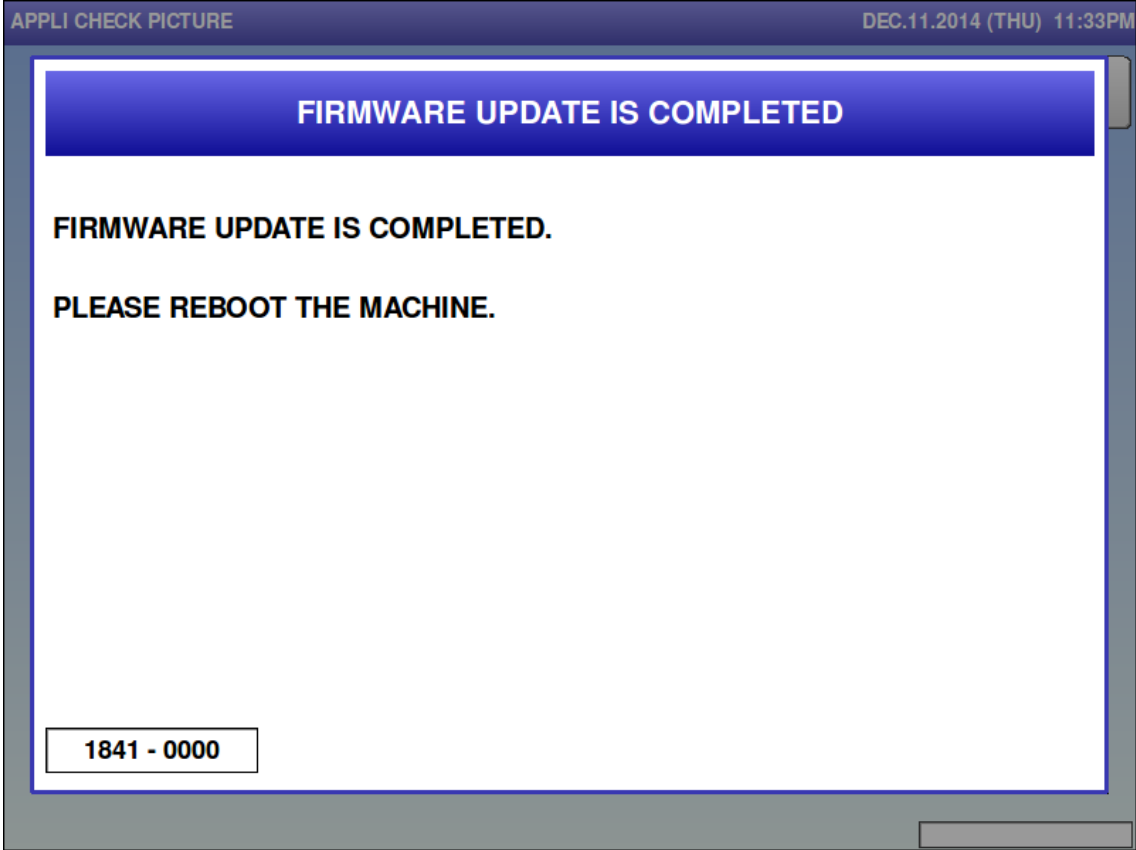

Error content	Program update has been completed.
Detail	Program update has been completed. Turn ON the power again.
Solution	
Action by user	
Action by service representative	
Related part	
Remarks	Display when the program is updated from SLP.

■ Power OFF (1842)

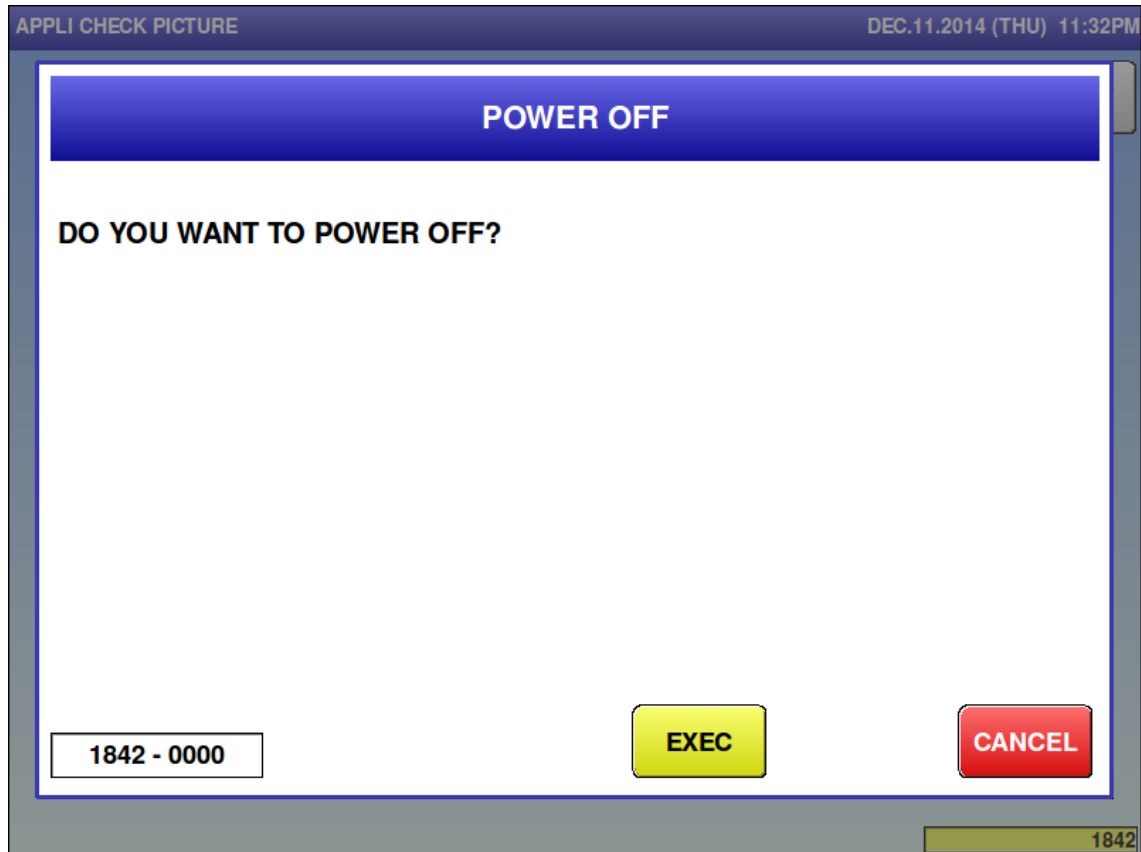

Error content	Confirm that the power supply is turned OFF.
Detail	Power OFF is checked when the power button is pressed.
Solution	Turn OFF the power supply by pressing the [EXEC] button. Pressing the [CANCEL] button returns to the original screen (screen where the power supply button was pressed).
Action by user	
Action by service representative	
Related part	
Remarks	Displayed only on the [IP] type.

■ Update program on remote (1860)

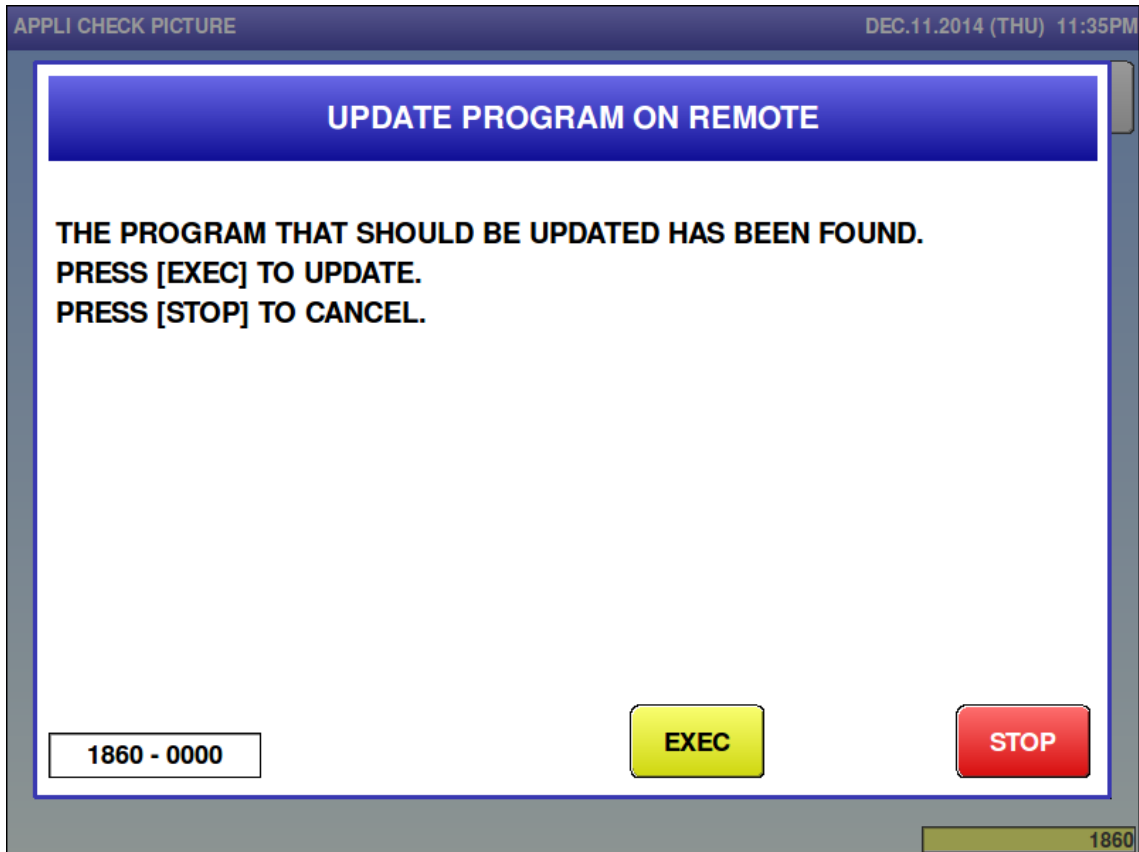

Error content	Confirm the program update remotely.
Detail	Update confirmation is performed when there is a program to be updated on the i global service when the power is ON.
Solution	Press the [EXEC] button to update the program from the cloud and restart after update. Press the [STOP] button to display clock confirmation.
Action by user	
Action by service representative	
Related part	
Remarks	Displayed when the i global service is enabled on [Settings: Machine No. (Global Service)], and there is an update program on the cloud service.

- Free 11 master is not registered (4201)

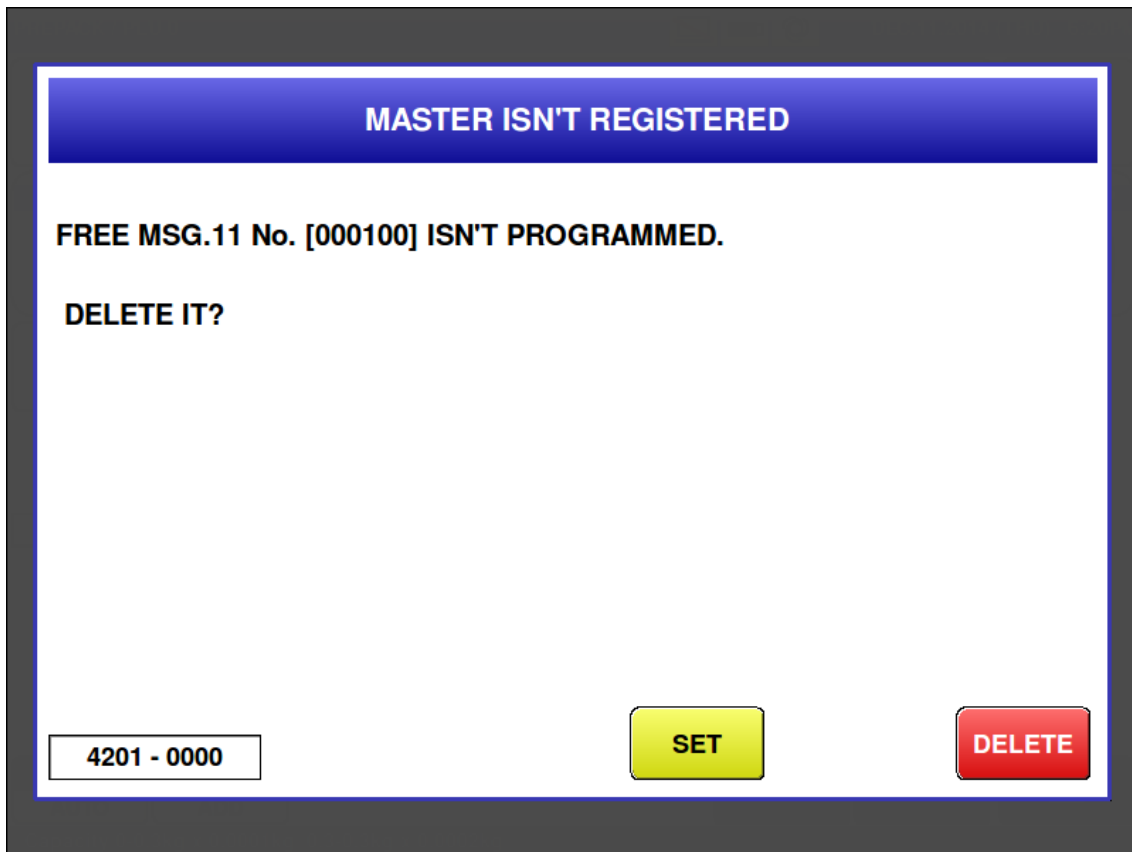

Error content	The called free 1 master has not been registered.
Detail	Does not exist in the internal master.
Solution	[DELETE] button => Delete free No.1 of product master. [SET] button => Cancel error.
Action by user	Reconfirm the free 1 master number. Add the free 1 master.
Action by service representative	Confirm the master.
Related part	Main board
Remarks	<ul style="list-style-type: none"> ▪ The called free 1 No. is displayed. ▪ In the case of no free 1 No. automatic update, product master is not changed. ▪ Error screen can be changed in link master error settings. ▪ Master name can be checked in "MENU TITLE (OPERATE) settings".

- Free 12 master is not registered (4202)

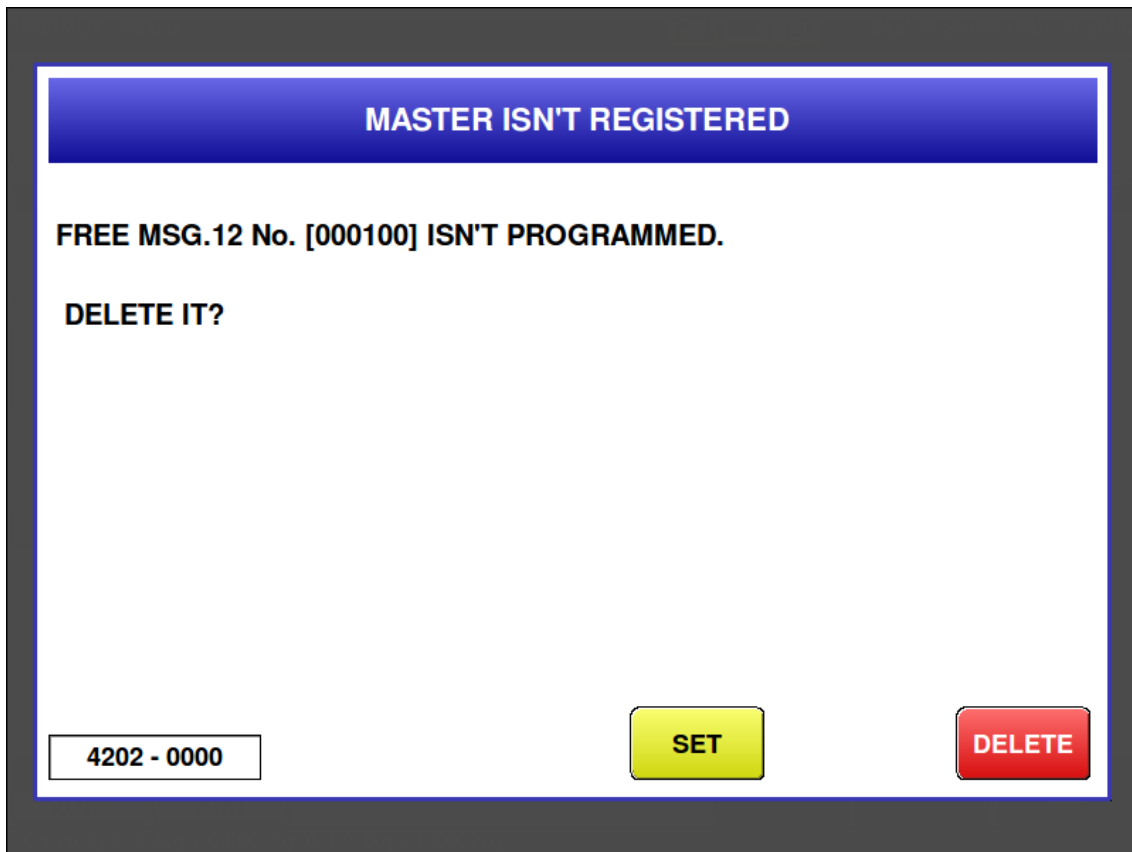

Error content	The called free 12 master has not been registered.
Detail	Does not exist in the internal master.
Solution	[DELETE] button => Delete free No.12 of product master. [SET] button => Cancel error.
Action by user	Reconfirm the free 12 master number. Add the free 12 master.
Action by service representative	Confirm the master.
Related part	Main board
Remarks	<ul style="list-style-type: none"> The called free 12 No. is displayed. In the case of no free 12 No. automatic update, product master is not changed. Error screen can be changed in link master error settings. Master name can be checked in "MENU TITLE (OPERATE) settings".

- Free 13 master is not registered (4203)

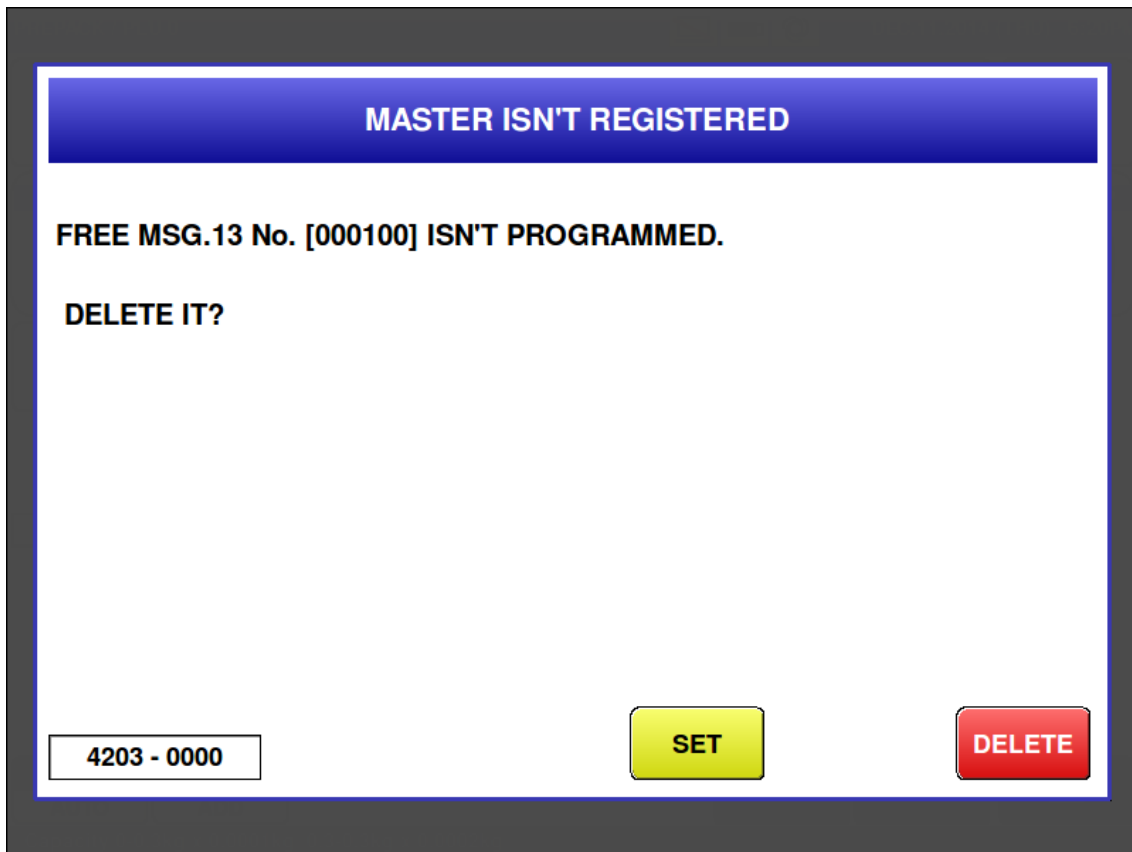

Error content	The called free 13 master has not been registered.
Detail	Does not exist in the internal master.
Solution	[DELETE] button => Delete free No.13 of product master. [SET] button => Cancel error.
Action by user	Reconfirm the free 13 master number. Add the free 13 master.
Action by service representative	Confirm the master.
Related part	Main board
Remarks	<ul style="list-style-type: none"> • The called free 13 No. is displayed. • In the case of no free 13 No. automatic update, product master is not changed. • Error screen can be changed in link master error settings. • Master name can be checked in "MENU TITLE (OPERATE) settings".

- Free 14 master is not registered (4204)

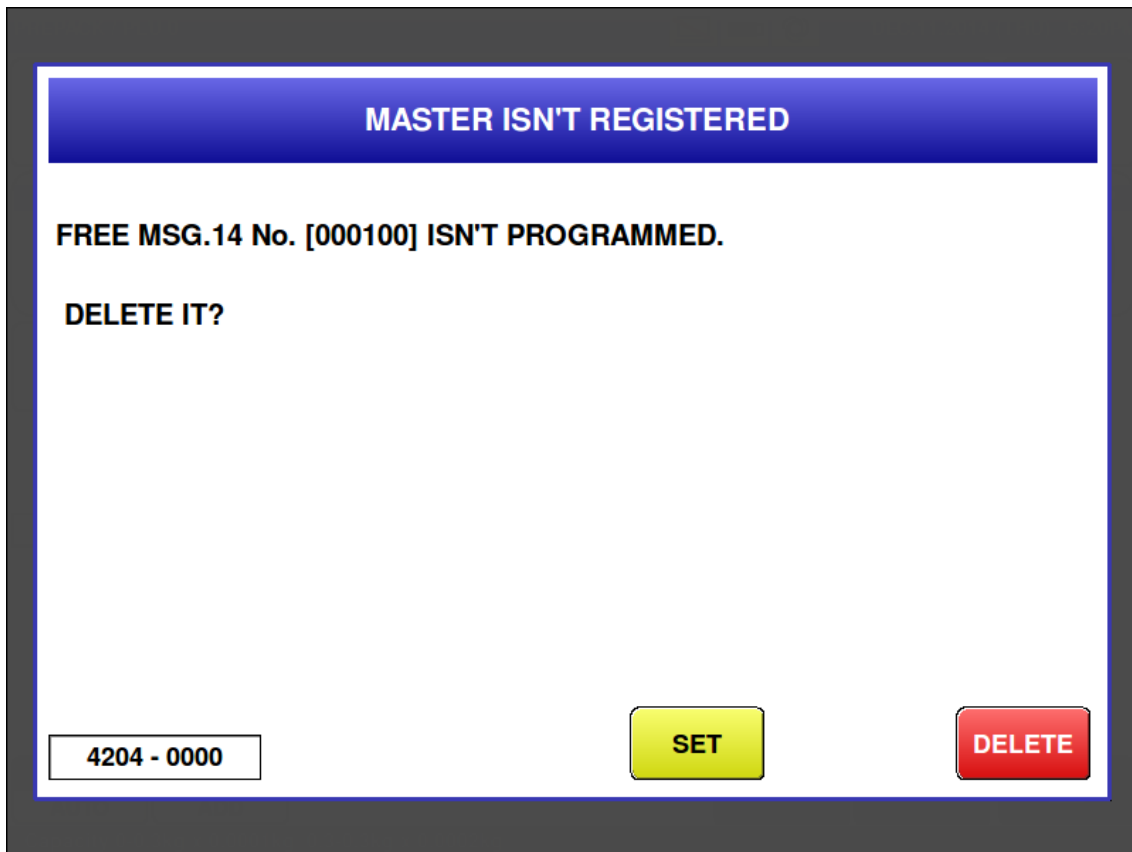

Error content	The called free 14 master has not been registered.
Detail	Does not exist in the internal master.
Solution	[DELETE] button => Delete free No.14 of product master. [SET] button => Cancel error.
Action by user	Reconfirm the free 14 master number. Add the free 14 master.
Action by service representative	Confirm the master.
Related part	Main board
Remarks	<ul style="list-style-type: none"> The called free 14 No. is displayed. In the case of no free 14 No. automatic update, product master is not changed. Error screen can be changed in link master error settings. Master name can be checked in "MENU TITLE (OPERATE) settings".

- Free 15 master is not registered (4205)

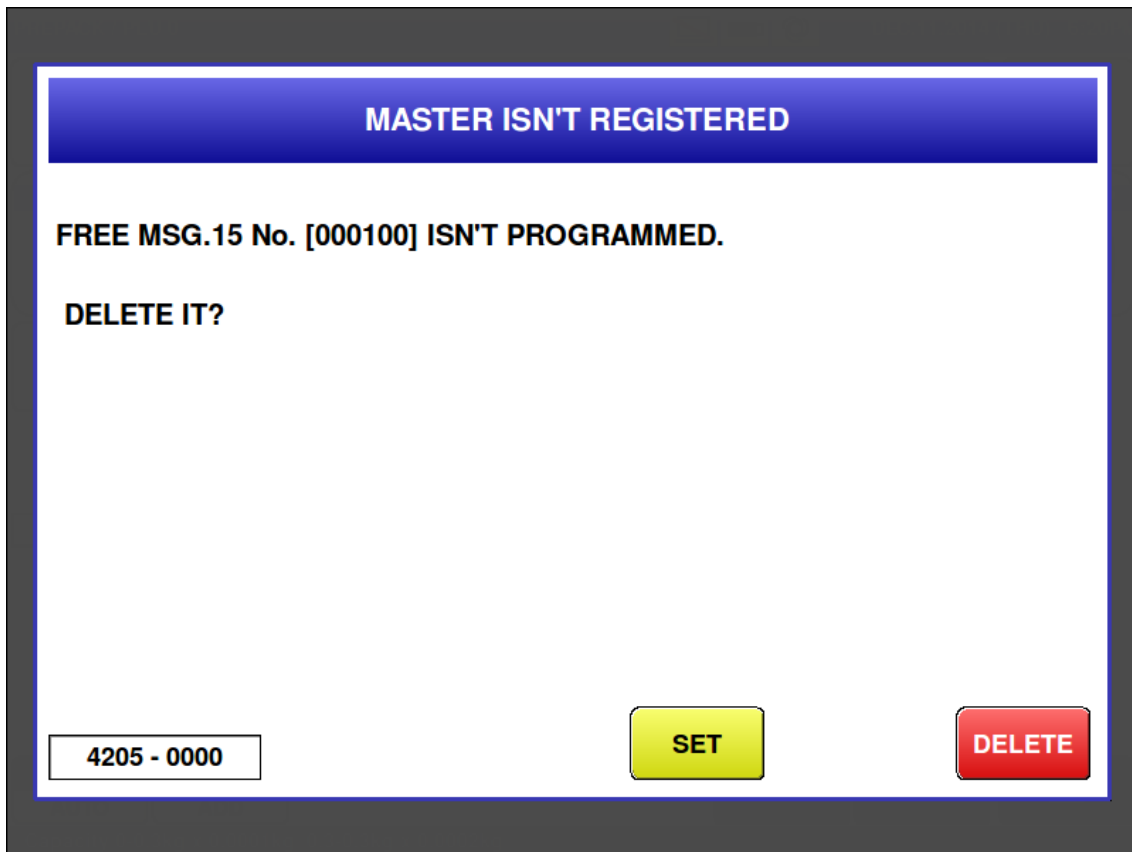

Error content	The called free 15 master has not been registered.
Detail	Does not exist in the internal master.
Solution	[DELETE] button => Delete free No.15 of product master. [SET] button => Cancel error.
Action by user	Reconfirm the free 15 master number. Add the free 15 master.
Action by service representative	Confirm the master.
Related part	Main board
Remarks	<ul style="list-style-type: none"> ▪ The called free 15 No. is displayed. ▪ In the case of no free 15 No. automatic update, product master is not changed. ▪ Error screen can be changed in link master error settings. ▪ Master name can be checked in "MENU TITLE (OPERATE) settings".

■ Coupon master is not registered (4206)

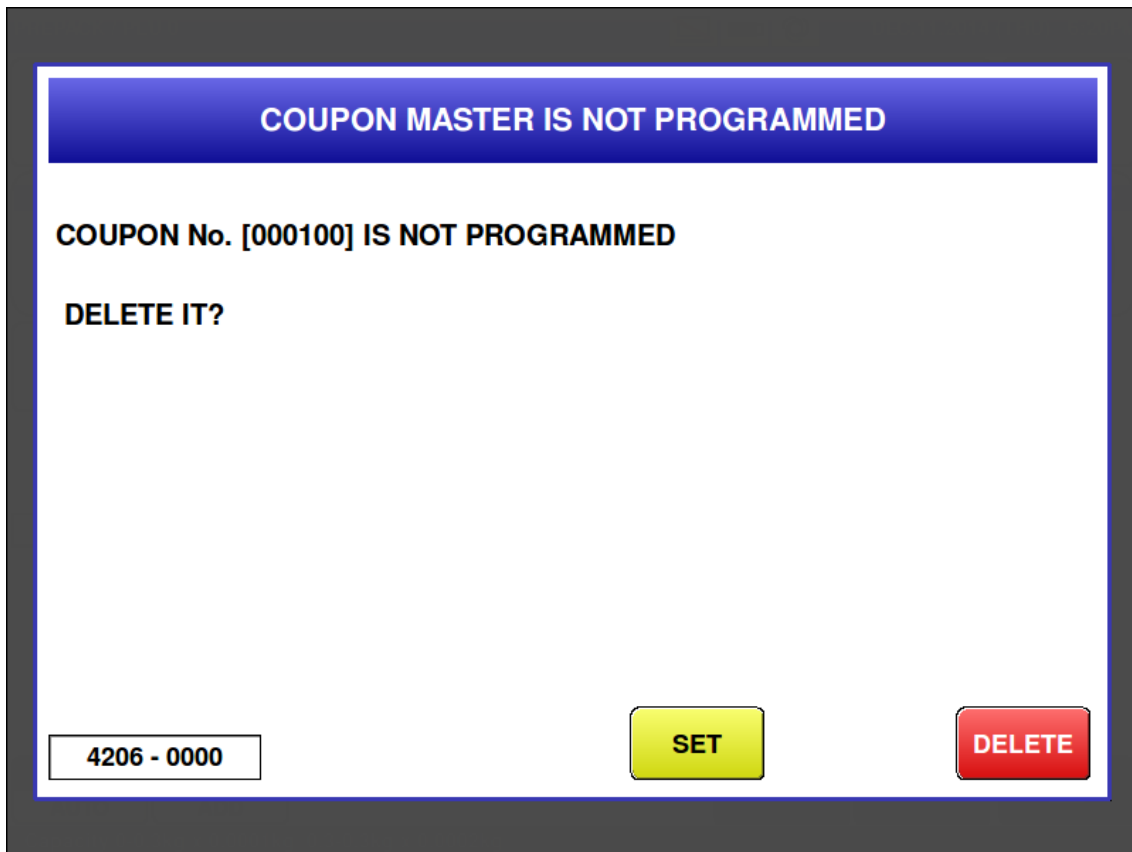

Error content	The called coupon master has not been registered.
Detail	Does not exist in the internal master.
Solution	[DELETE] button => Delete coupon No. of product master. [SET] button => Cancel error.
Action by user	Reconfirm the coupon master number. Add the coupon master.
Action by service representative	Confirm the master.
Related part	Main board
Remarks	<ul style="list-style-type: none"> ▪ The called coupon No. is displayed. ▪ In the case of no coupon No. automatic update, product master is not changed. ▪ Error screen can be changed in link master error settings. ▪ Master name can be checked in "MENU TITLE (OPERATE) settings".

Chapter 7 Options

7.1 Static Elimination Rope

When using a film that generates much static electricity, install a static elimination rope at the position shown in the figure below.

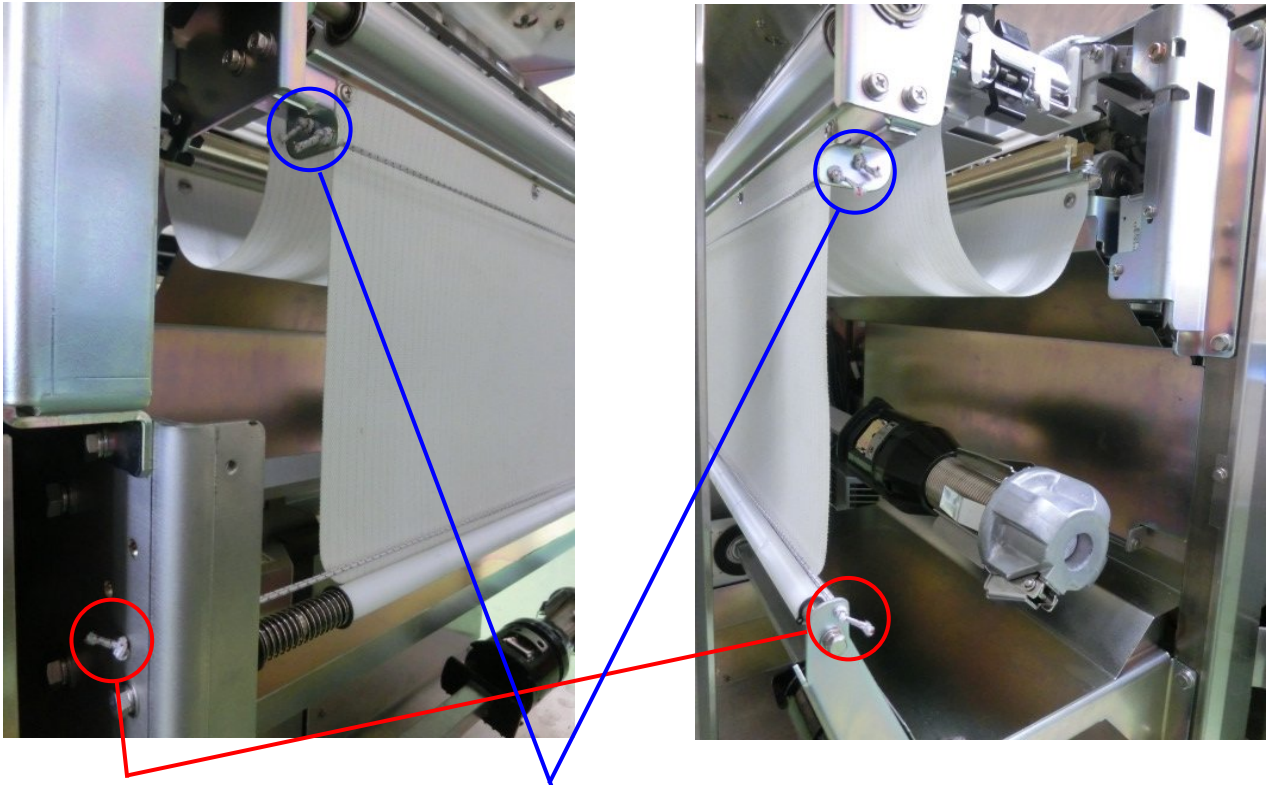

WIRE: STATIC ELECTRICITY
REMOVAL L: 500 1 pc.
For lower roll

WIRE: STATIC ELECTRICITY REMOVAL L: 450 2 pcs.
For upper and lower rolls
(Two pieces must be installed even for one roll specification)

Install the static elimination rope while pulling it because of its elasticity.

Make a knot in the rope outside of the sheet metal so that the static elimination rope may not come off.

7.2 LAN Cable Wiring

7.2.1 Wiring Procedure

Step 1. Remove four (①, ②, ③, ⑤) covers.

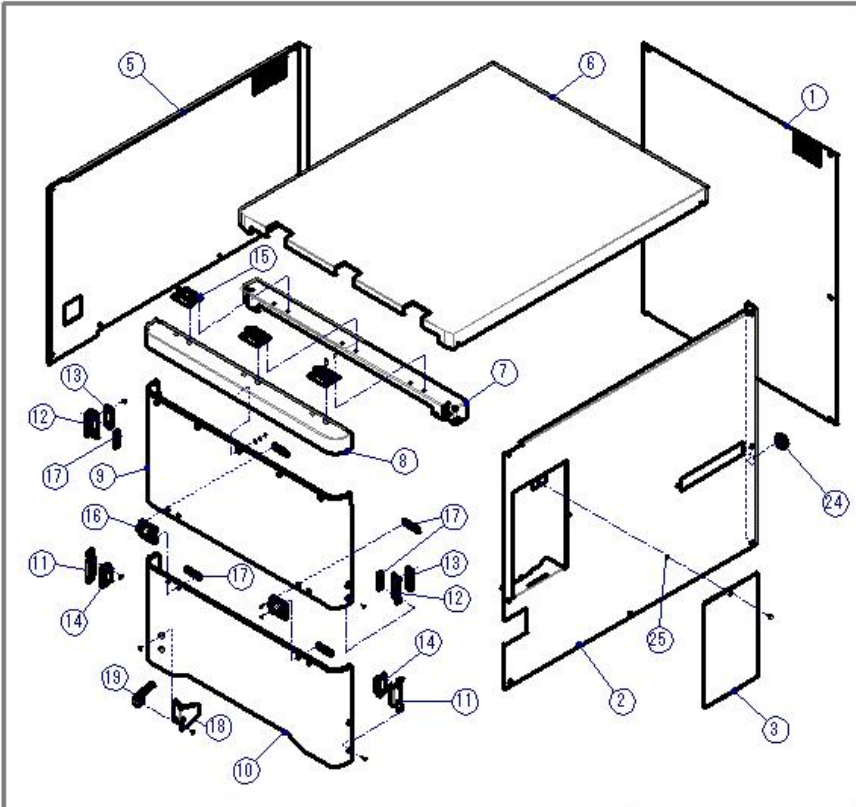

Step 2. LAN cable path 1 (Inside the cover ②).

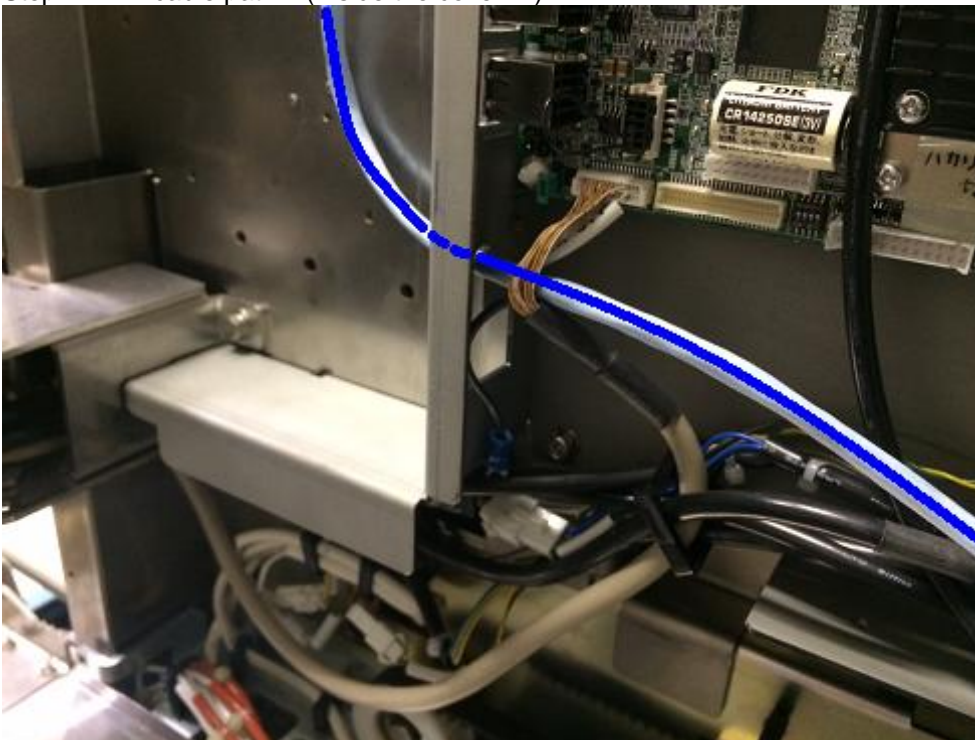

Step 3. LAN cable path 2 (Inside the cover ②).

Fix them with cable ties.

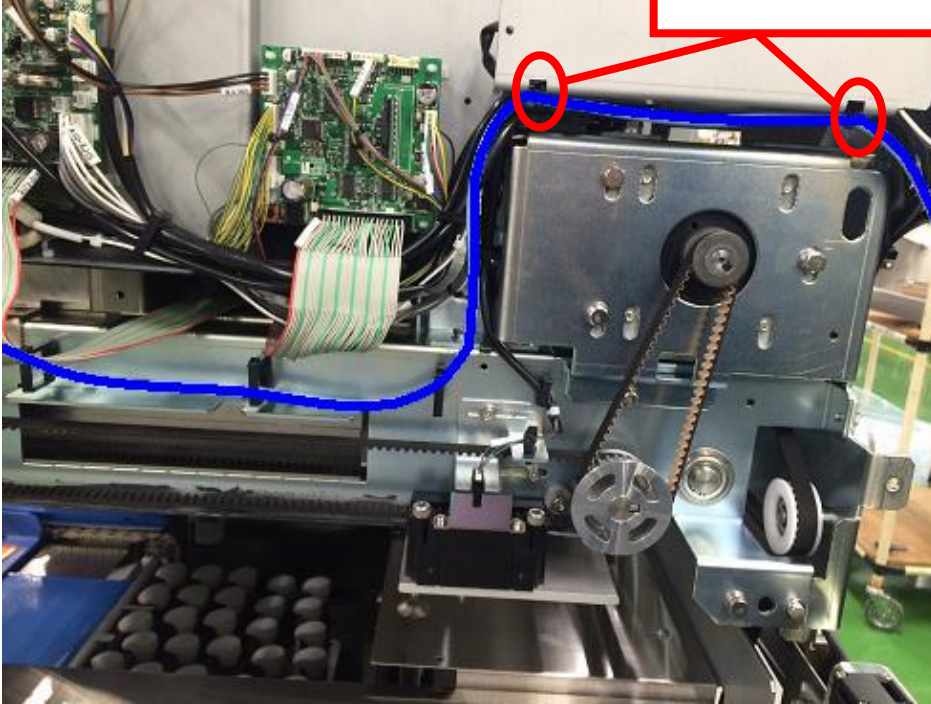

Step 4. Connect the supplied LAN cable inside the cover ③.

Note: I perform the connection of the connector after the wiring of the LAN cable.



Step 5. Mount the cover that has been removed in Step 1.

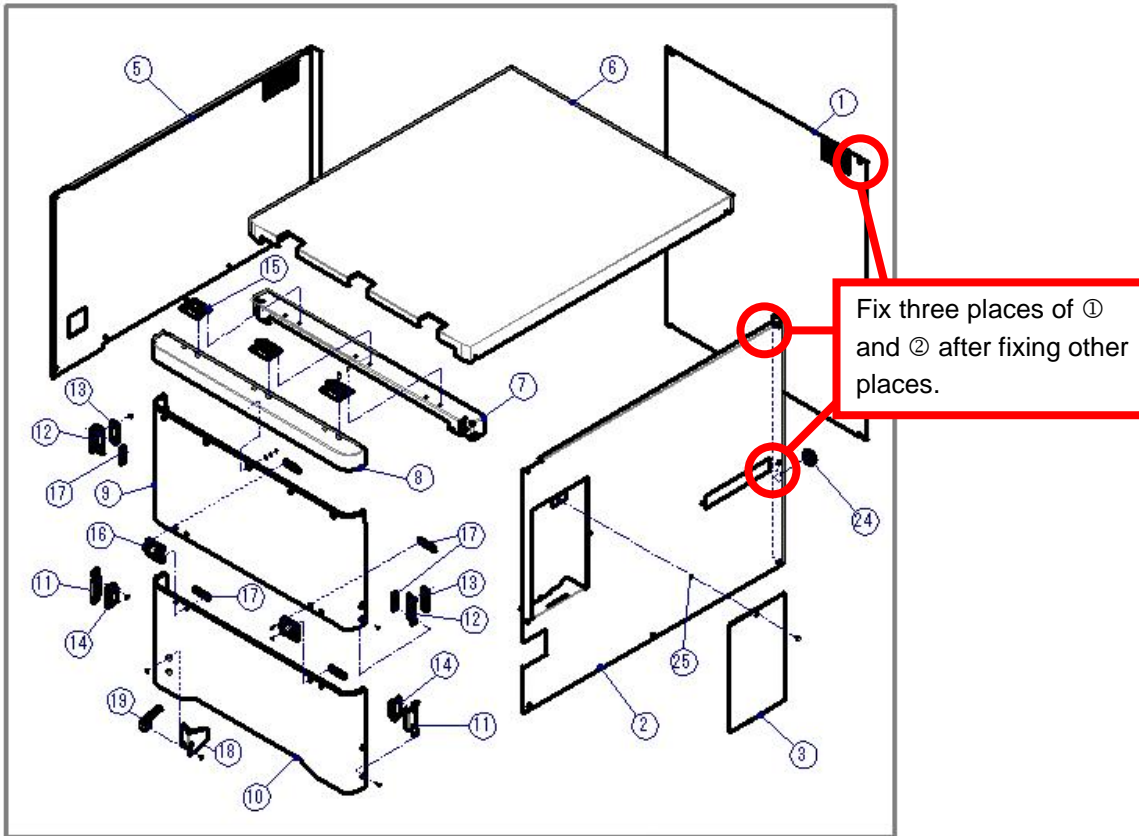

7.3 Wi-PORT

7.3.1 Package Content

<input type="checkbox"/> Wireless LAN AS	1
<input type="checkbox"/> Cover	1
<input type="checkbox"/> Hexagon head bolt with flange	1
<input type="checkbox"/> Antenna	1
<input type="checkbox"/> Nylon clamp	2
<input type="checkbox"/> Hexagon nut	1
<input type="checkbox"/> LAN cable	1
<input type="checkbox"/> Power supply harness	1

7.3.2 Installation Procedure

Step 1. Remove four covers (①, ②, ③ and ⑤).

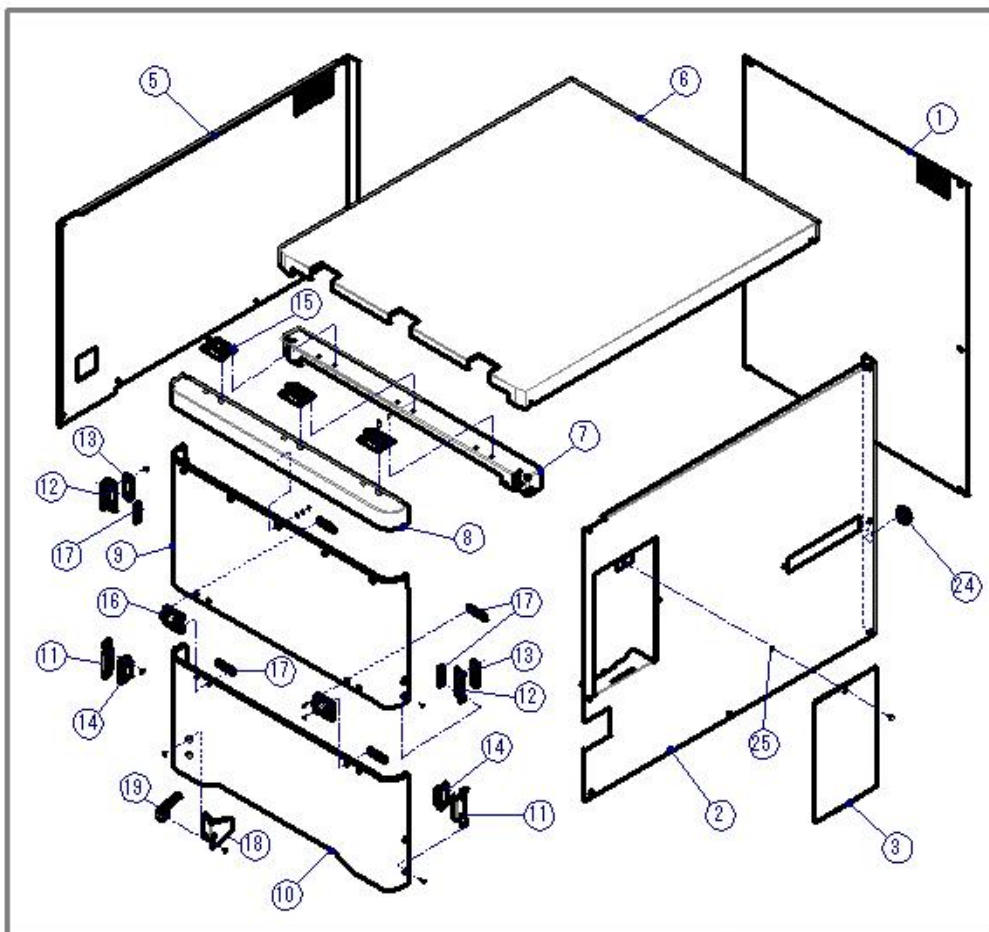

Step 2. Connect the supplied power supply harness to “XJ24” and “XJ25” of “A100 Board” inside the cover ©.

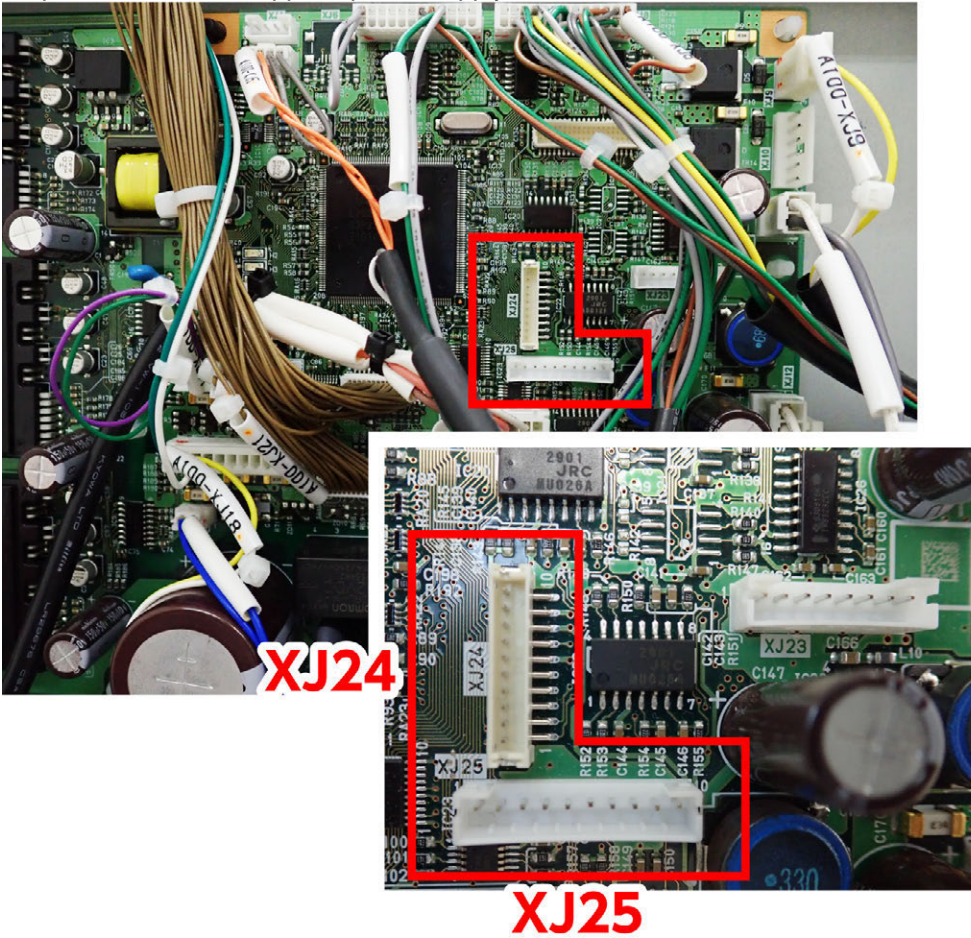

Step 3. Path 1 of the power supply harness (Inside the cover ©).

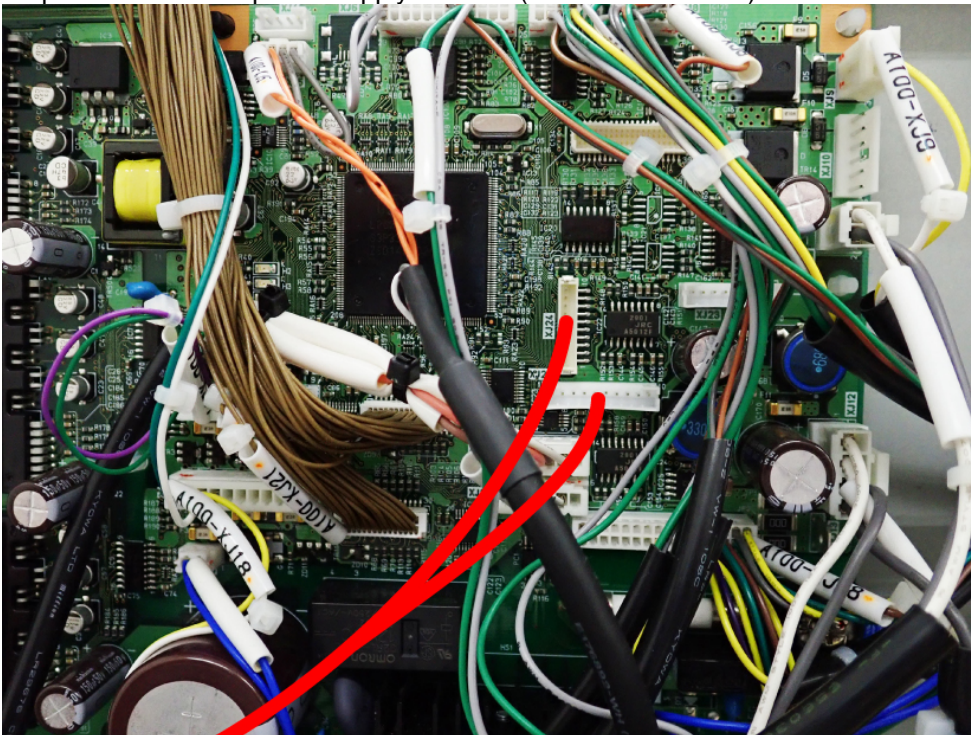

Step 4. Path 2 of the power supply harness (Inside the cover ①).

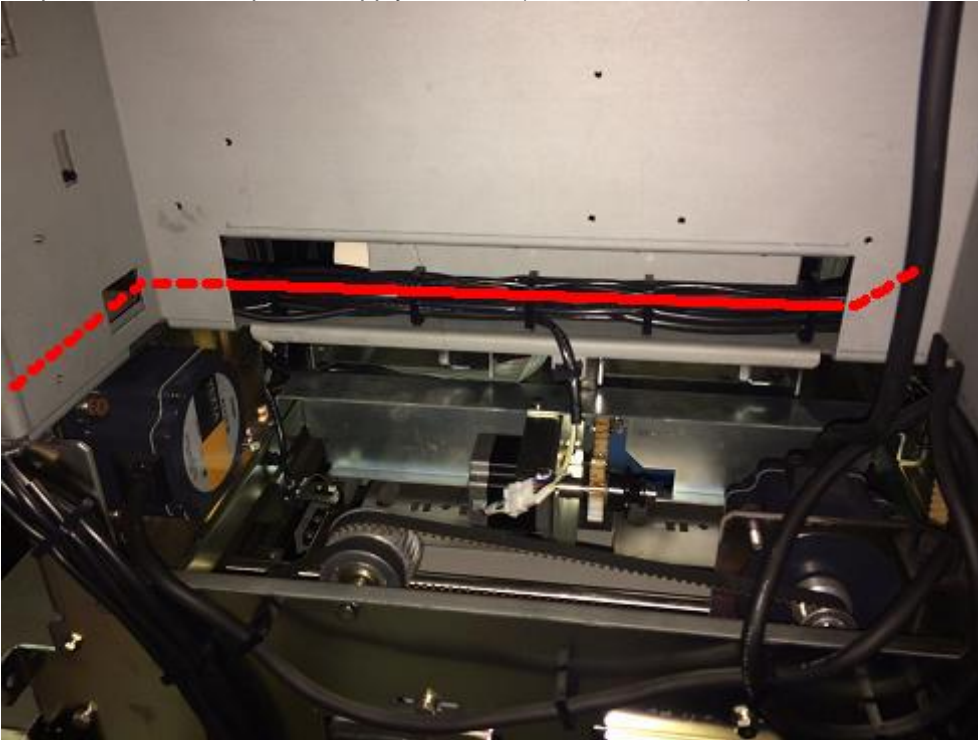

Step 5. Path 3 of the power supply harness (Inside the cover ②).

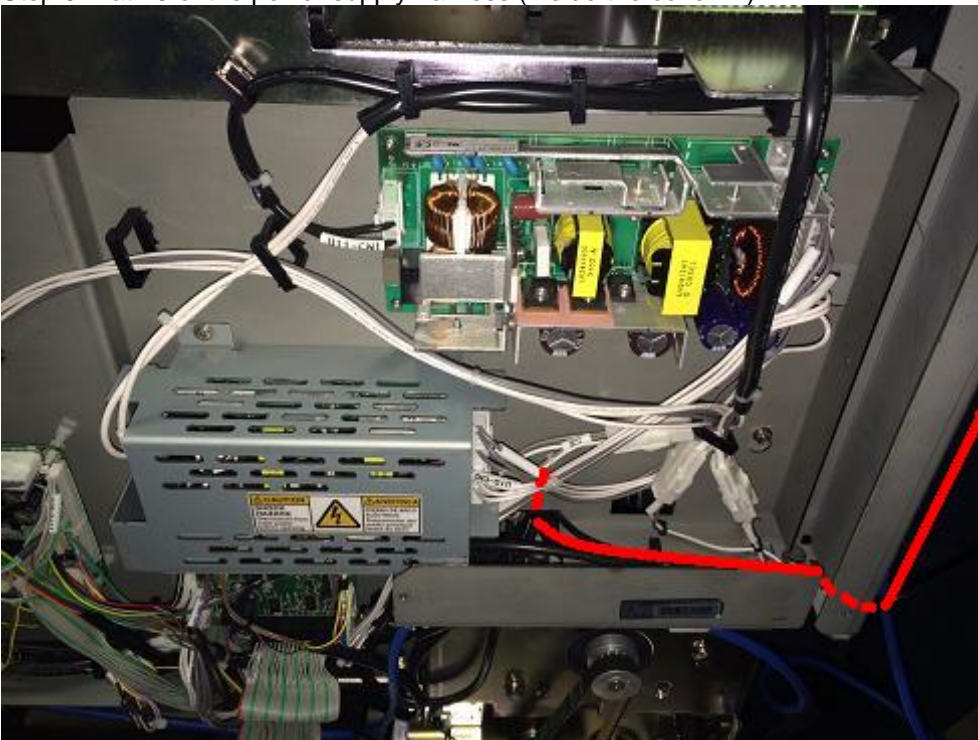

Step 6. LAN cable path 1 (Inside the cover ②).

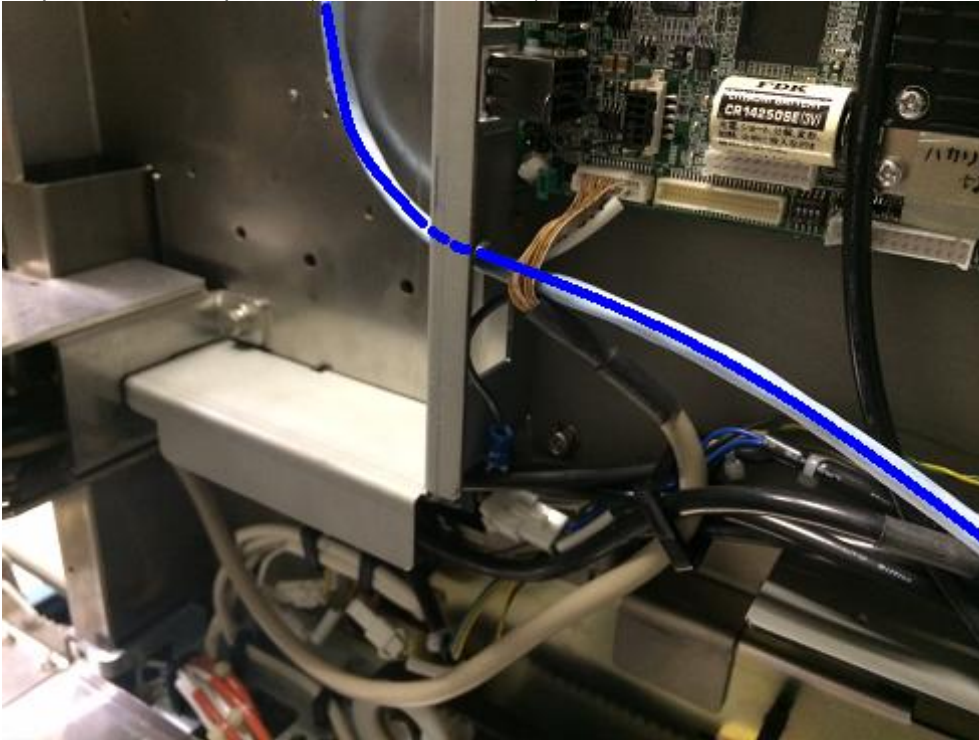

Step 7. LAN cable path 2 (Inside the cover ②).

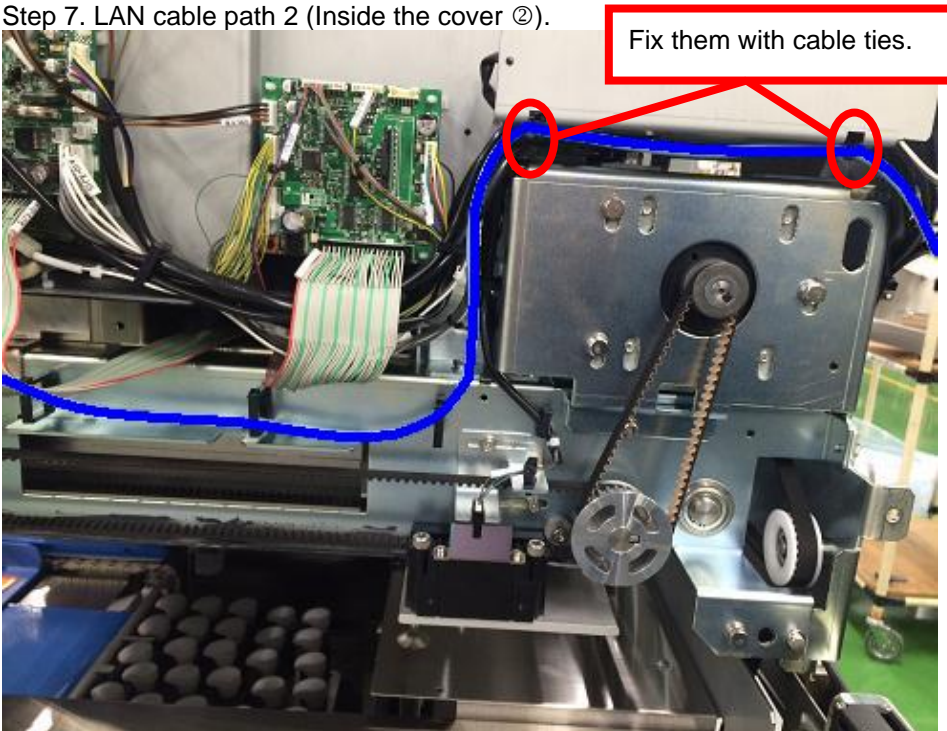

Step 8. Connect the supplied LAN cable inside the cover ③.

Note: Perform the connection of the connector after the wiring of the LAN cable.



Step 9. Mount the cover that has been removed on Step 1.

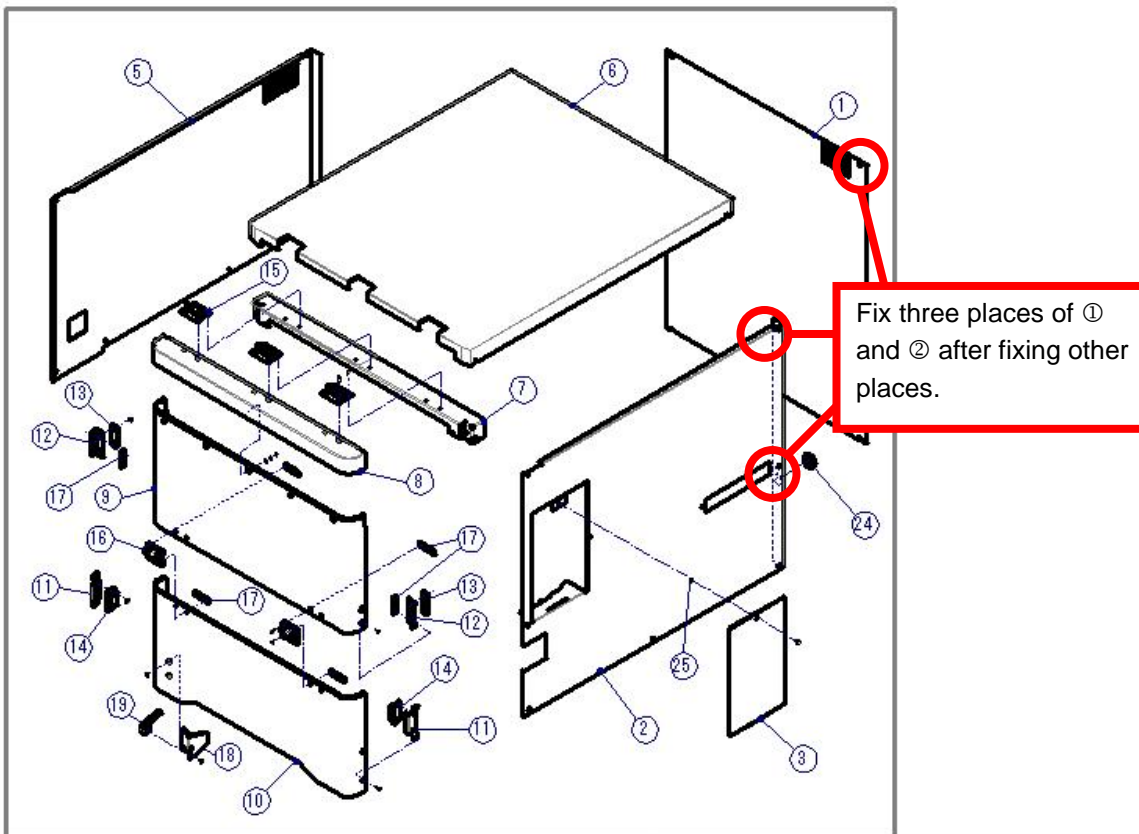

Step 10. Connect the power supply harness and LAN cable to the Wi-PORT board and fix them with the nylon clamp.

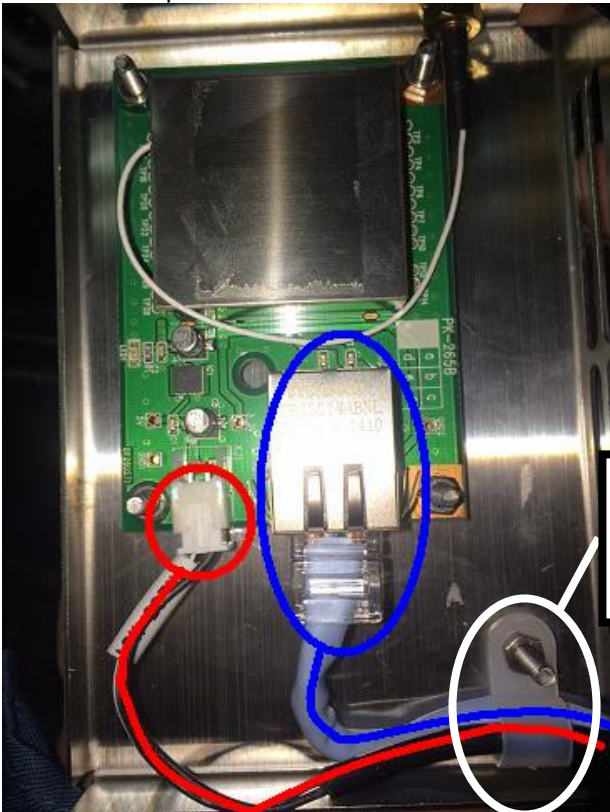

Insert two harnesses into the supplied nylon clamp and fix them with the hexagon nut.

Step 11. Mount the Wi-PORT cover.



Fix the cover with the supplied hexagon head bolt with flange.

Step 12. Mount the Wi-PORT antenna.



Screw the supplied antenna into the cover.

Step 13. Mount the Wi-PORT to the main body.

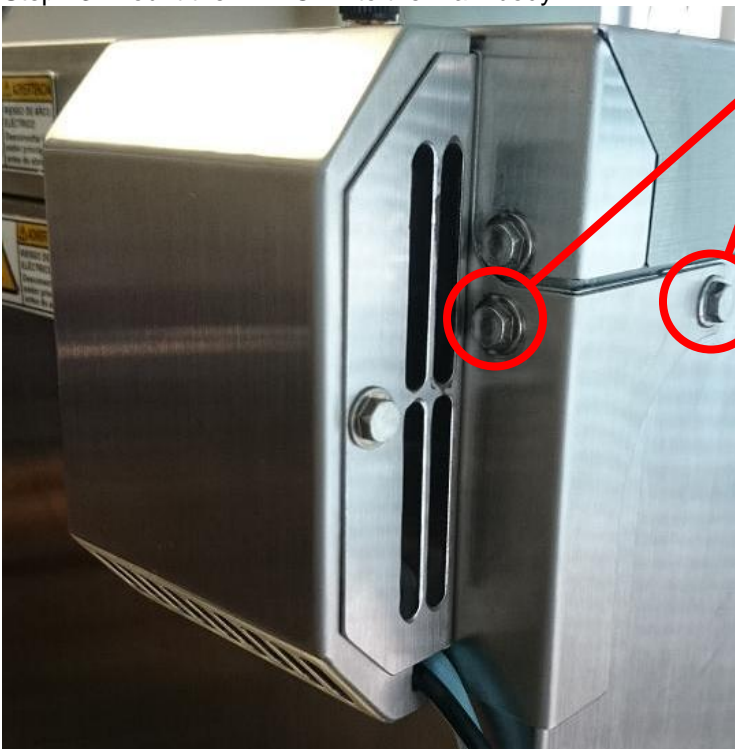

Use the installed hexagon head bolts with flange to mount the Wi-PORT to the main body.

Step 14. Path of the LAN cable and power supply harness.

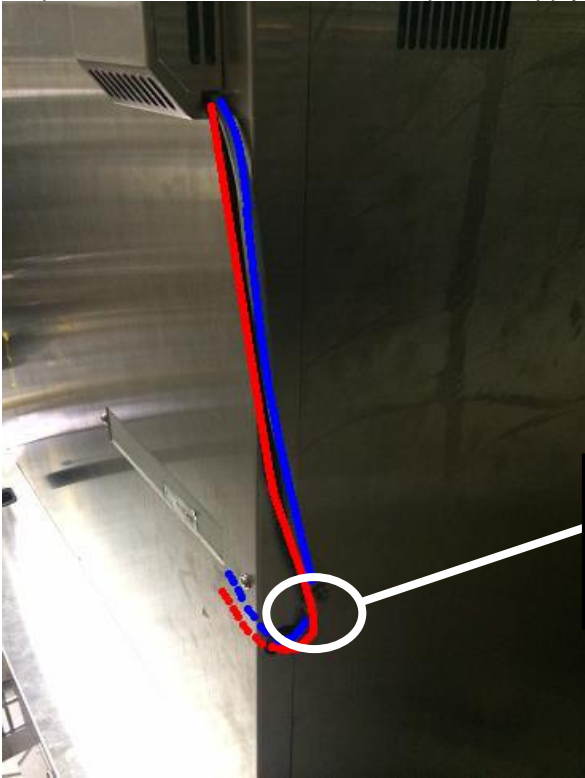

Insert two harnesses into the supplied nylon clamp and fix them with the installed hexagon head bolt with flange.

7.4 Human Detection Sensor (J)

7.4.1 Package Content

1	PLATE B: FILTER: SENSOR	1	
2	BRACKET: SENSOR: HUMAN BODY	1	
3	COVER: DISCHARGE	1	
4	HEX BOLT: BOLT&WASHER AS S2P2:	2	M4x8
5	SCREW: CROSS FLAT HEAD:	2	M3x6
6	SCREW: CROSS PAN HEAD:	2	M3x6
7	SENSOR:	1	
8	HARNESS:C2: SENSOR	1	

7.4.2 Installation Procedure

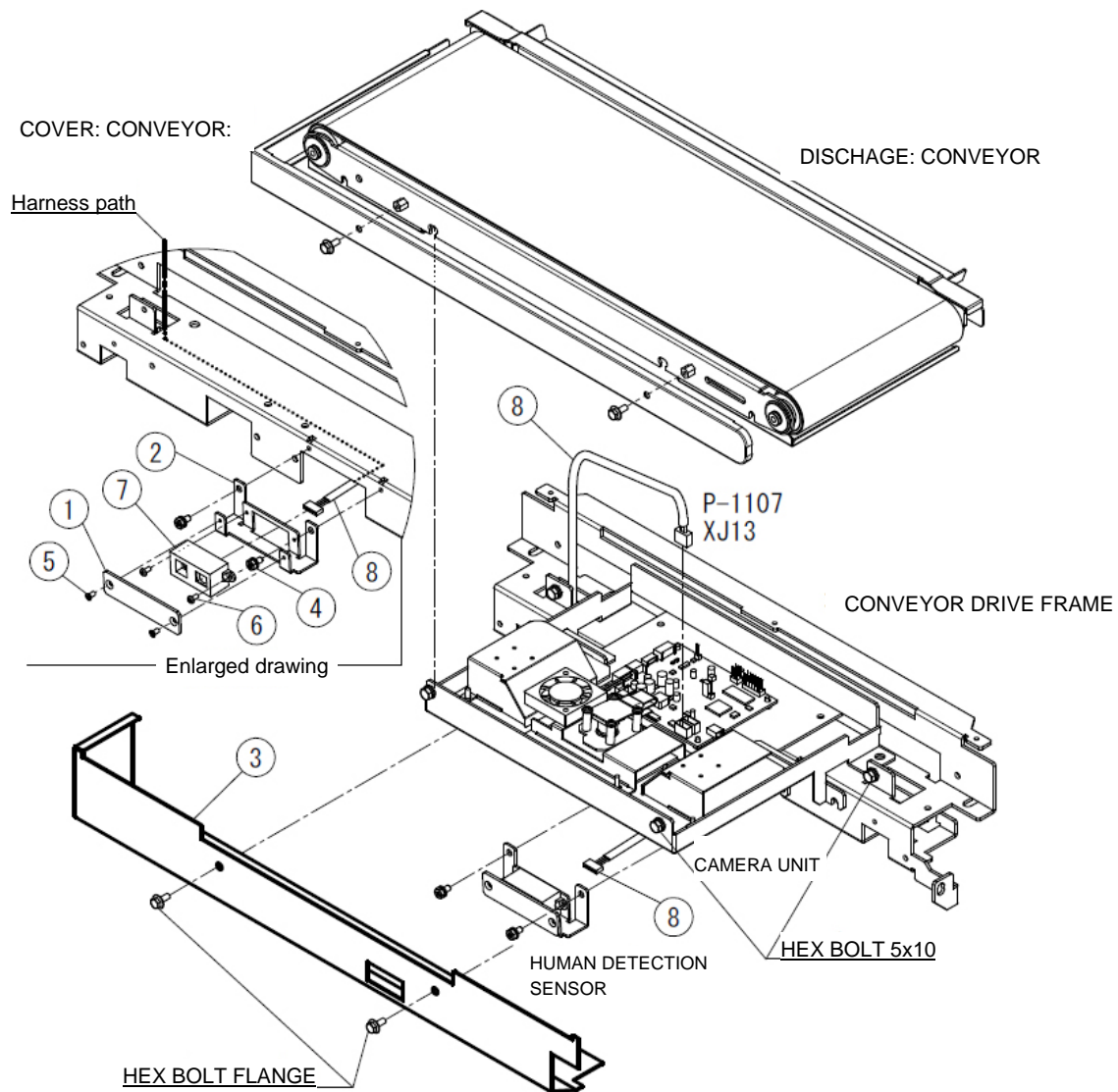

Step 1. Use the supplied screw ⑥ to mount the sensor ⑦ to the bracket ②.

Use the supplied screw ⑤ to mount the plate ①.

Step 2. Remove the COVER: DISCHARGE ③.

(HEX BOLT FLANGE 4x6: x2)

Step 3. Remove two HEX BOLT FLANGES to remove the COVER: CONVEYOR.

(HEX BOLT FLANGE 4x6: x2)

Step 4. Loosen four HEX BOLTS to remove the DISCHARGE CONVEYOR.

(HEX BOLT M5x10)

Step 5. Insert harness ⑧ into the frame from the left hole, connect the connector to the sensor assembled on Step 1 and use the supplied screw ④ to install to the frame.

Step 6. Connect the other connector to XJ13 of P-1107.

Step 7. Put the DISCHARGE CONVEYOR back to the original position and mount the COVER CONVEYOR.

(HEX BOLT M5 x 10)

(HEX BOLT FLANGE 4 X 6: x2)

Step 8. Mount the COVER ③ instead of the cover that has been removed on Step 2.

(HEX BOLT FLANGE 4 x 6: x2)

(COVER in which the sensor's detection hole is open.)

Step 9. Turn ON the power supply and see the Service Manual to make settings.

7.5 Human Detection Sensor (Standard)

7.5.1 Package Content

1	PLATE B: FILTER: SENSOR	1	
2	BRACKET: SENSOR: HUMAN BODY	1	
3	COVER: DISCHARGE	1	
4	HEX BOLT: BOLT&WASHER AS S2P2:	2	M4 x 8
5	SCREW: CROSS FLAT HEAD:	2	M3 x 6
6	SCREW: CROSS PAN HEAD:	2	M3 x 6
7	SENSOR:	1	
8	THREADED ROD: HEX:MF	2	
9	HARNESS:C2: SENSOR	1	

7.5.2 Installation Procedure

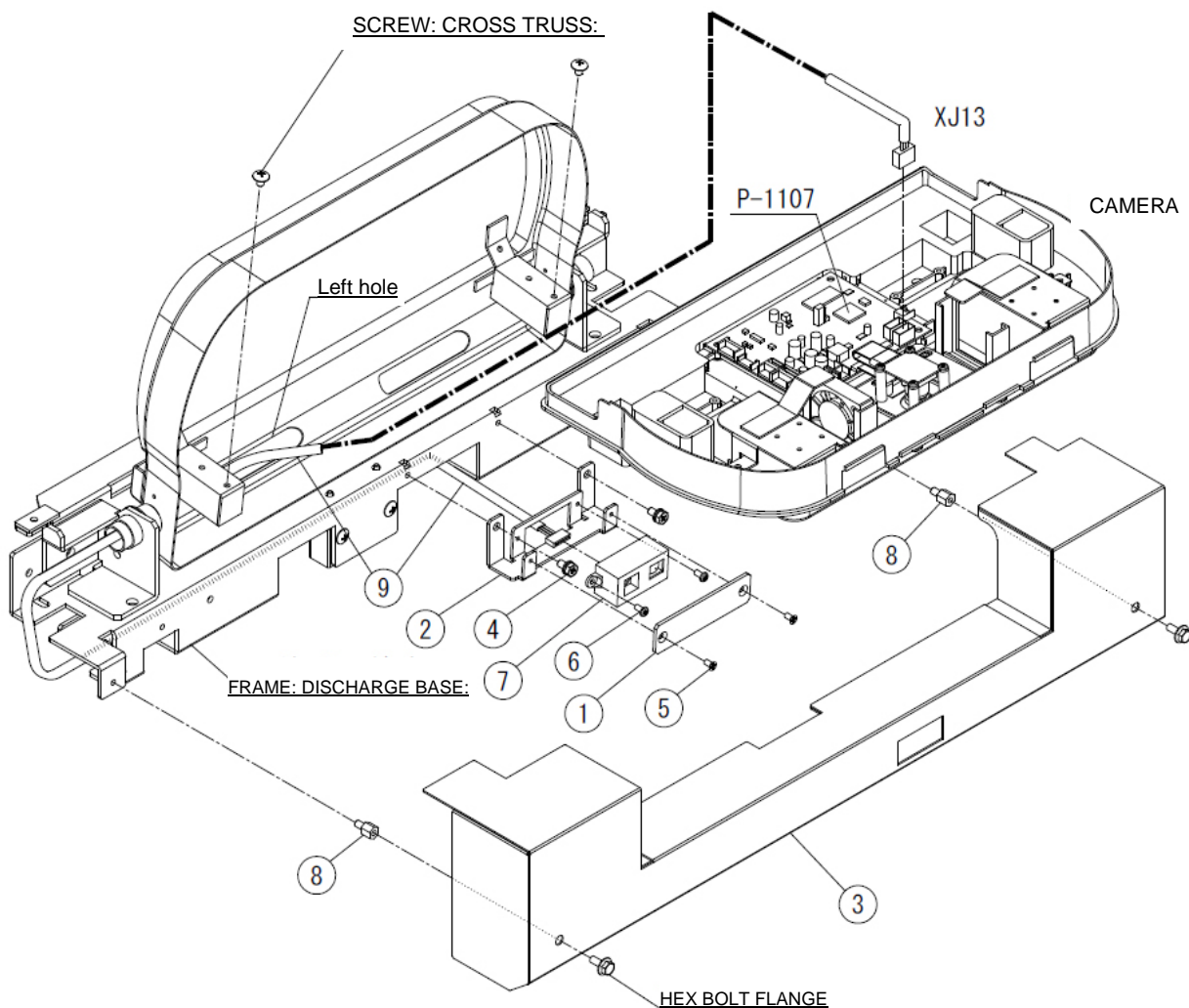

- Step 1. Use the supplied screw ⑥ to mount the sensor ⑦ to the bracket ②.
Use the supplied screw ⑤ to mount the plate ①.
- Step 2. Remove the COVER: DISCHARGE ③.
(HEX BOLT FLANGE 4x6: x2)
- Step 3. Set the DISCHARGE BASE (CAMERA UNIT).
- Step 4. Remove two SCREW: CROSS TRUSS: and remove the CAMERA UNIT from the DISCHARGE BASE.
- Step 5. Insert harness ⑧ into the frame from the left hole, connect the connector to the sensor assembled on Step 1 and use the supplied screw ④ to install to the frame.
- Step 6. Connect the other connector to XJ13 of P-1107, fit it to the DISCHARGE BASE and fix it with SCREW: CROSS TRUSS:
- Step 7. Put the DISCHARGE BASE back on the level.
- Step 8. Mount the THREADED ROD ⑨ and mount the cover ⑩ instead of the cover that has been removed on Step 2.
(HEX BOLT FLANGE 4x6: x2) (COVER in which the sensor's detection hole is open.)
- Step 9. Turn ON the power supply and see the Service Manual to make settings.

7.6 On-board Lighting

7.6.1 Package Content

- ON-BOARD LIGHTING PS 1
- HEX BOLT 2

7.6.2 Installation Procedure

Step 1. Remove the upper film changer cover and fix the ON-BOARD LIGHTING AS with the supplied HEX BOLT.

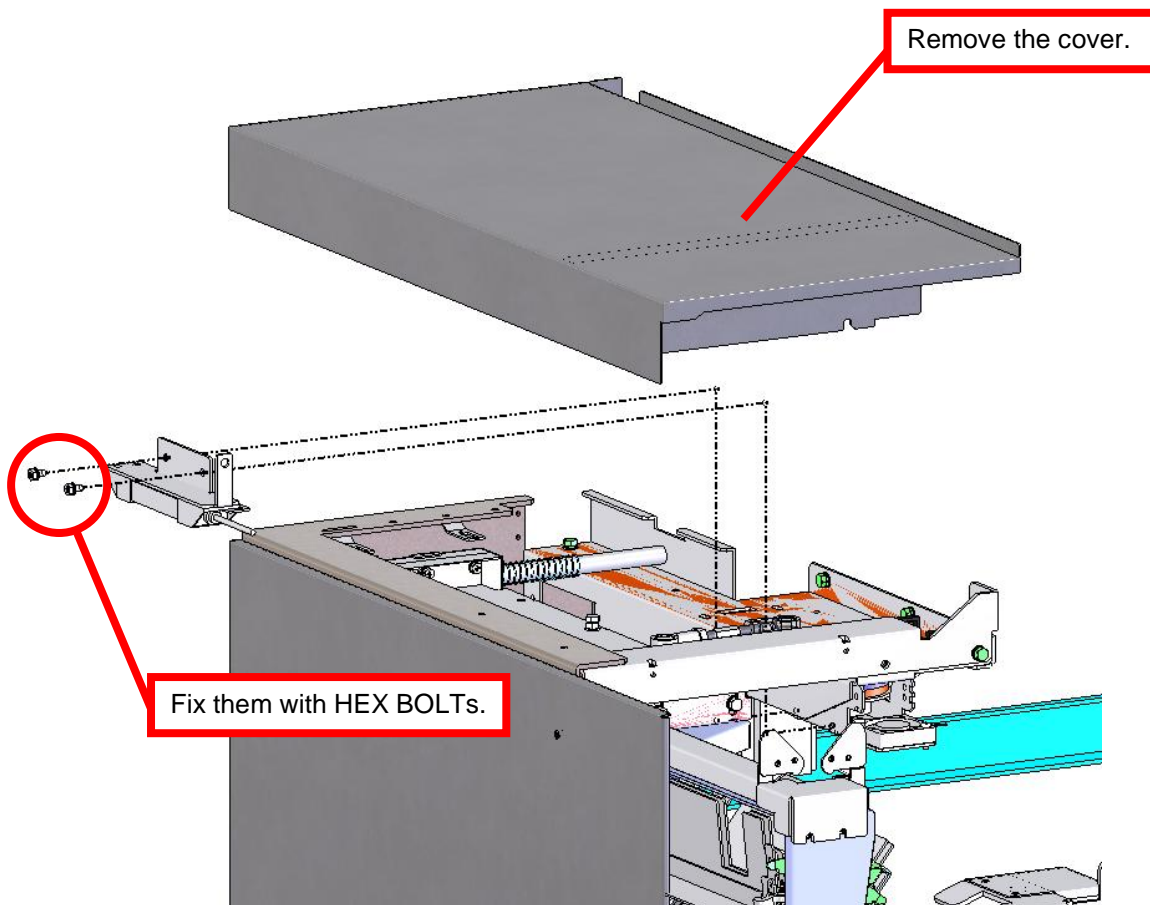

Step 2. Fix the harnesses of ON-BOARD LIGHTING AS with the cable ties. (x3)

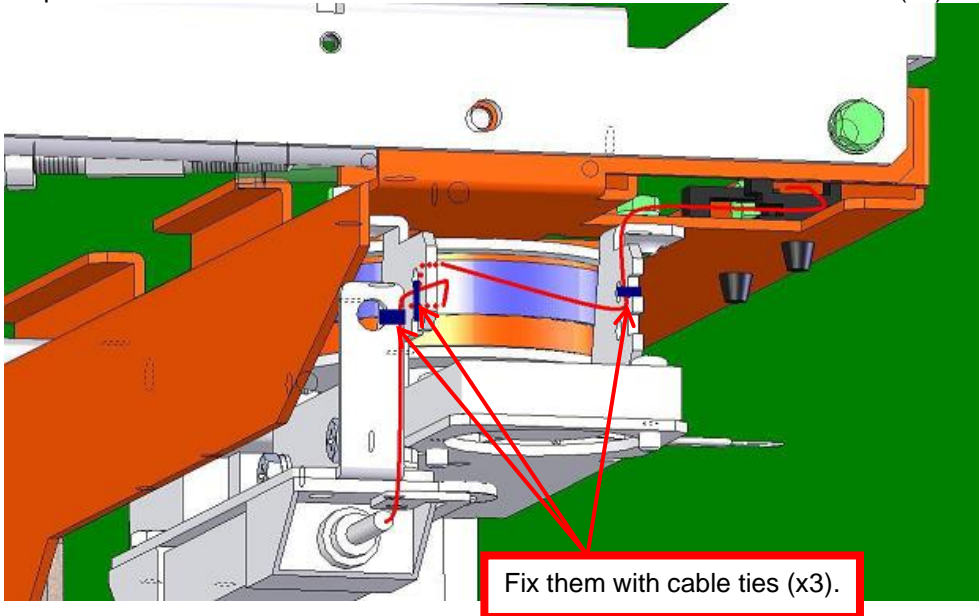

Step 3. Connect to the connector of No ring: H300S.

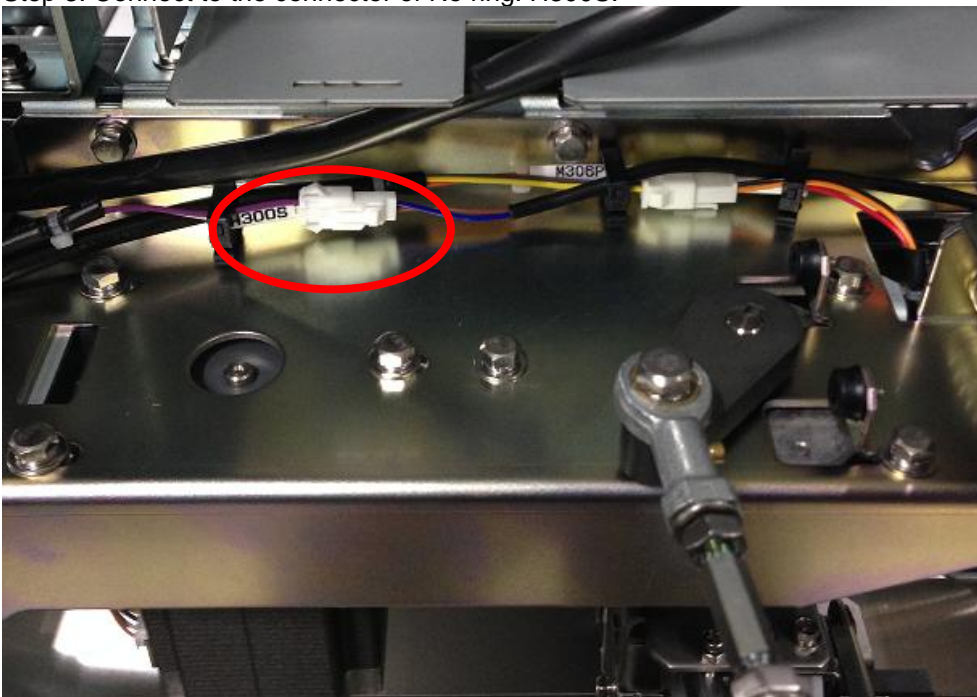

Step 4. Mount the removed cover.

Step 5. Check the operation.

Check that the LED lights when opening the film replacement door.

7.7 File Stand

7.7.1 Package Content

1	STAND: PRODUCT NAME FILE	1	
2	BRACKET: PRODUCT NAME FILE	1	
3	TAPPING SCREW: CROSS TRUSS: T2	2	M4 x 16
4	HEX BOLT: BOLT&WASHER AS S2P2:	4	M4 x 8

Accessories: Plastic folder x 1

7.7.2 Installation Procedure

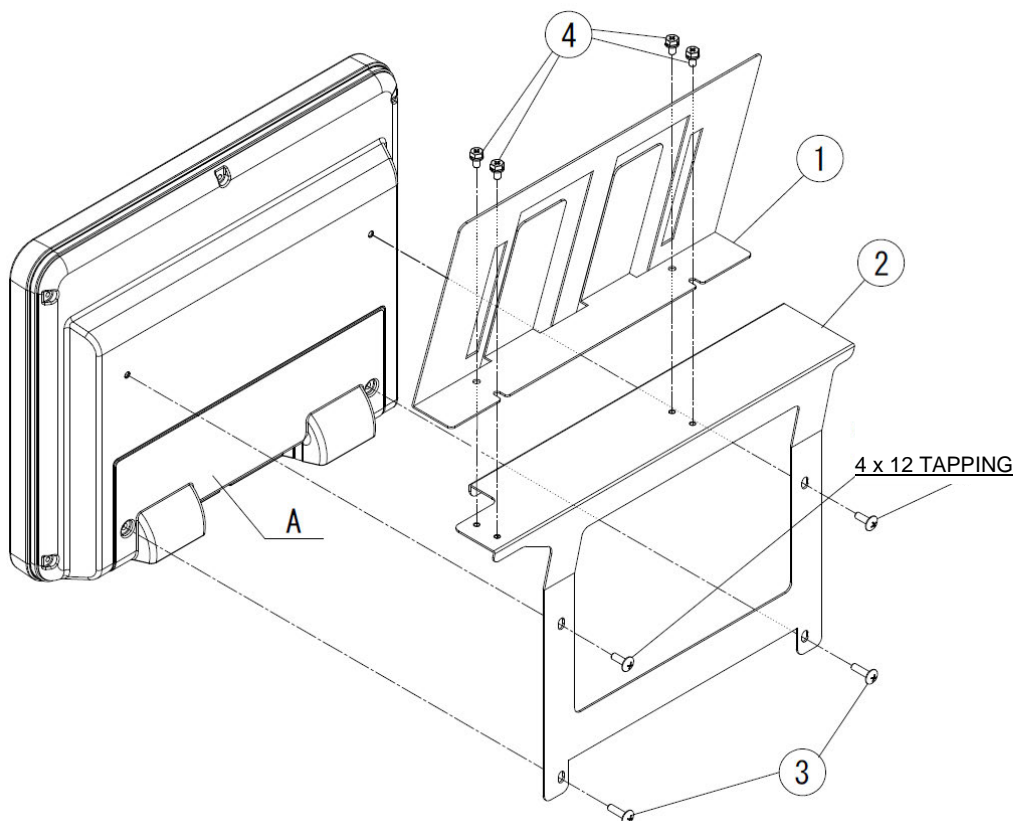

Step 1. Mount the BRACKET ② and STAND ① with HEX BOLT: BOLT&WASHER AS S2P2: ④.

Step 2. Remove the TAPPING SCREWS (4 x 12) from the A connector cover resin.

Step 3. Hook the BRACKET ② with the stand mounted on the top of the display, and use TAPPING TRUSS ③ at the bottom and two TAPPING SCREWS at the top to mount the BRACKET on the back of the display.

Chapter 8 Appendix

8.1 Operation Sequence

8.1.1 At Start-up

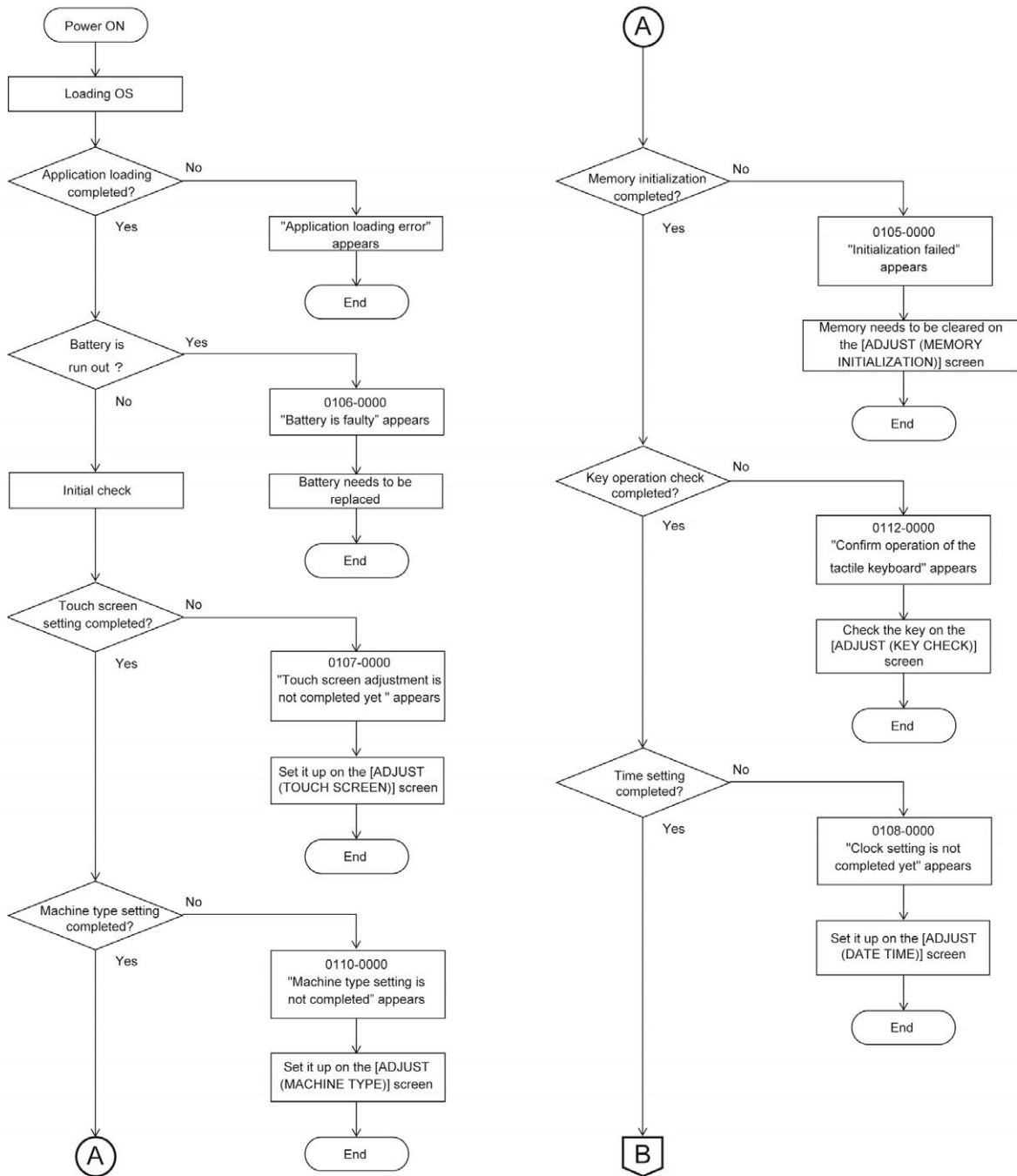

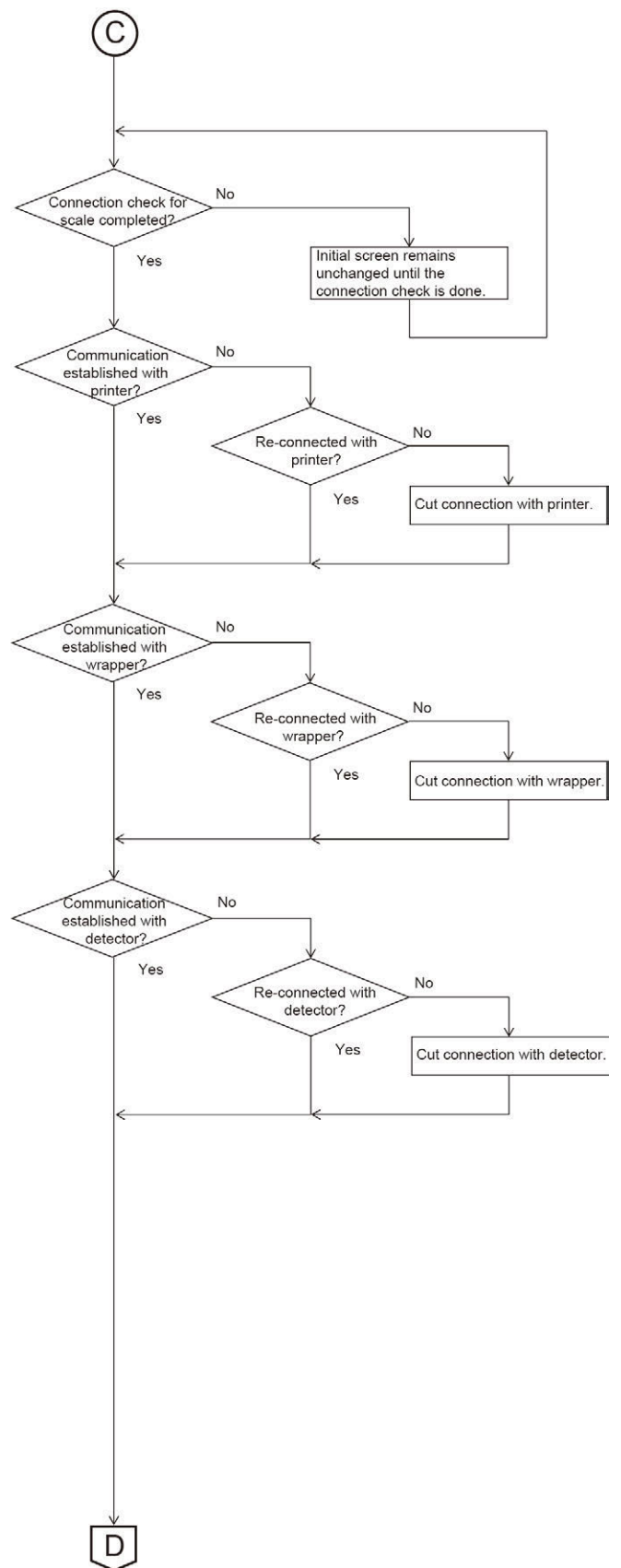
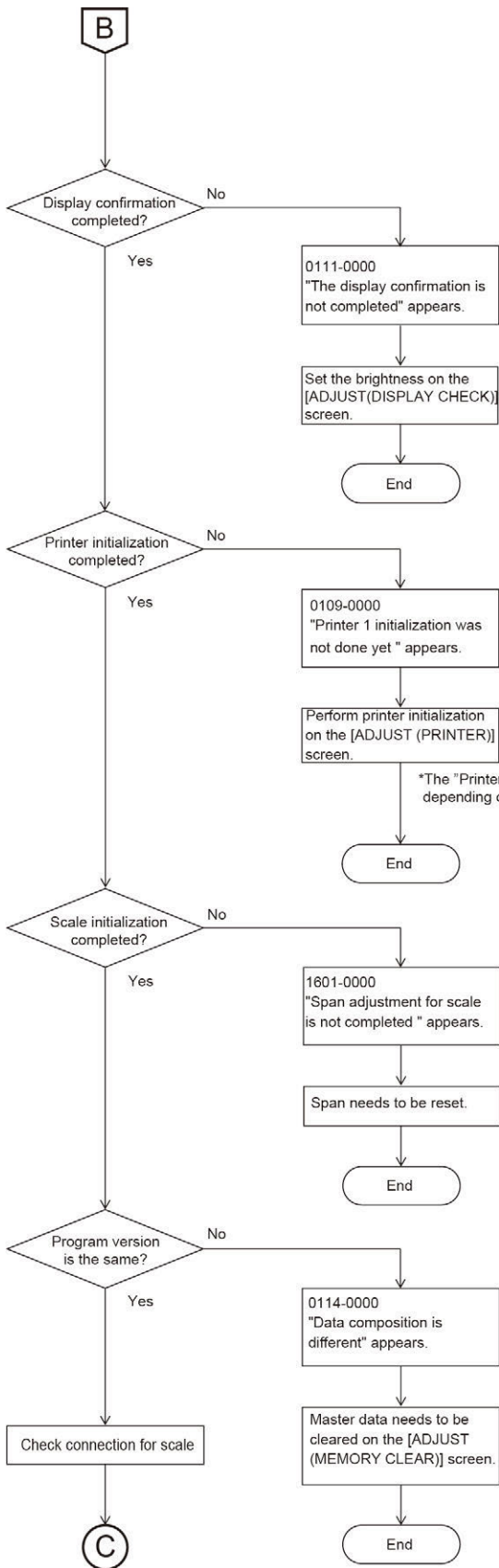

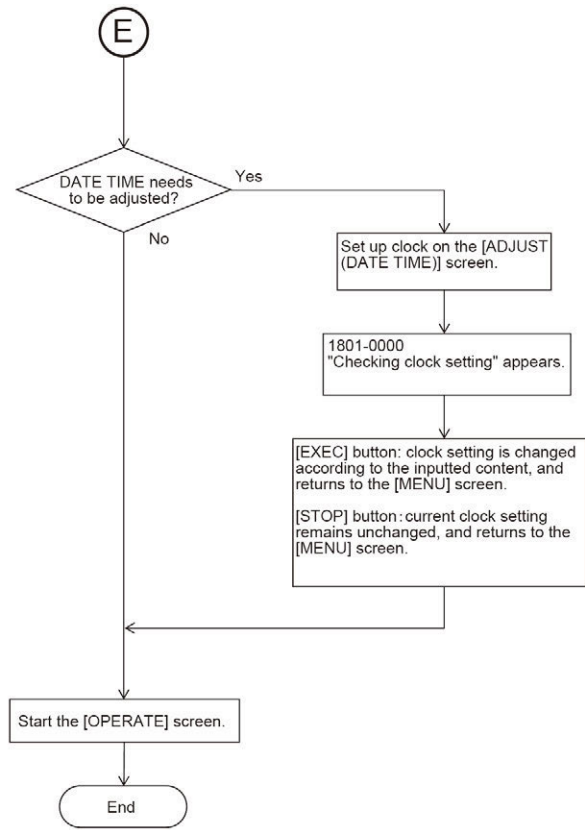
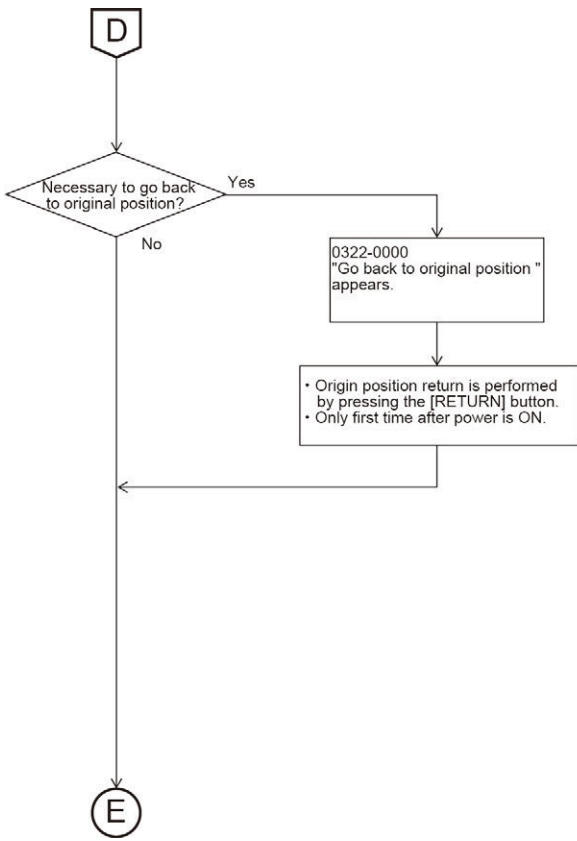

8.1.2 When Issuing Labels

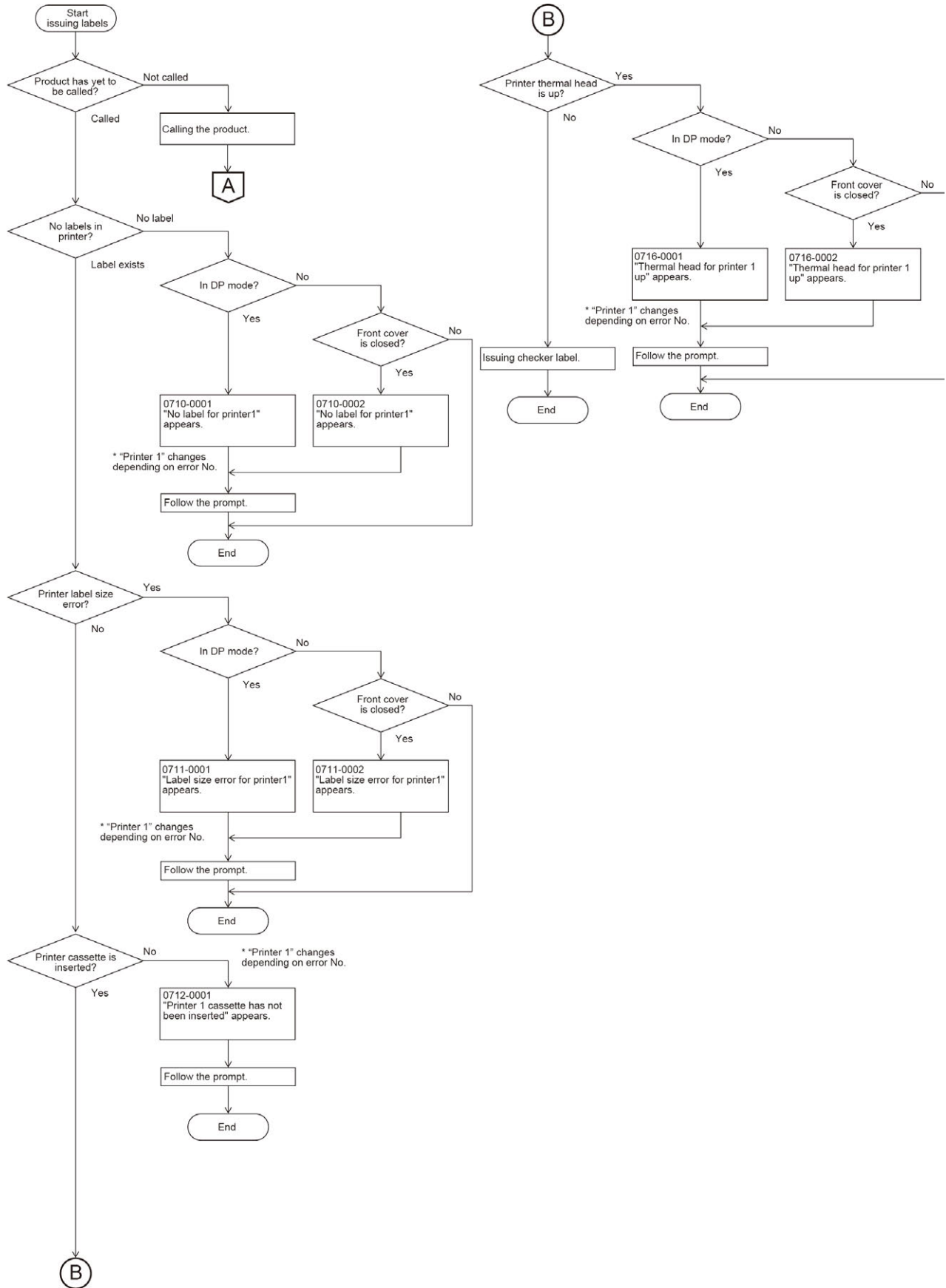

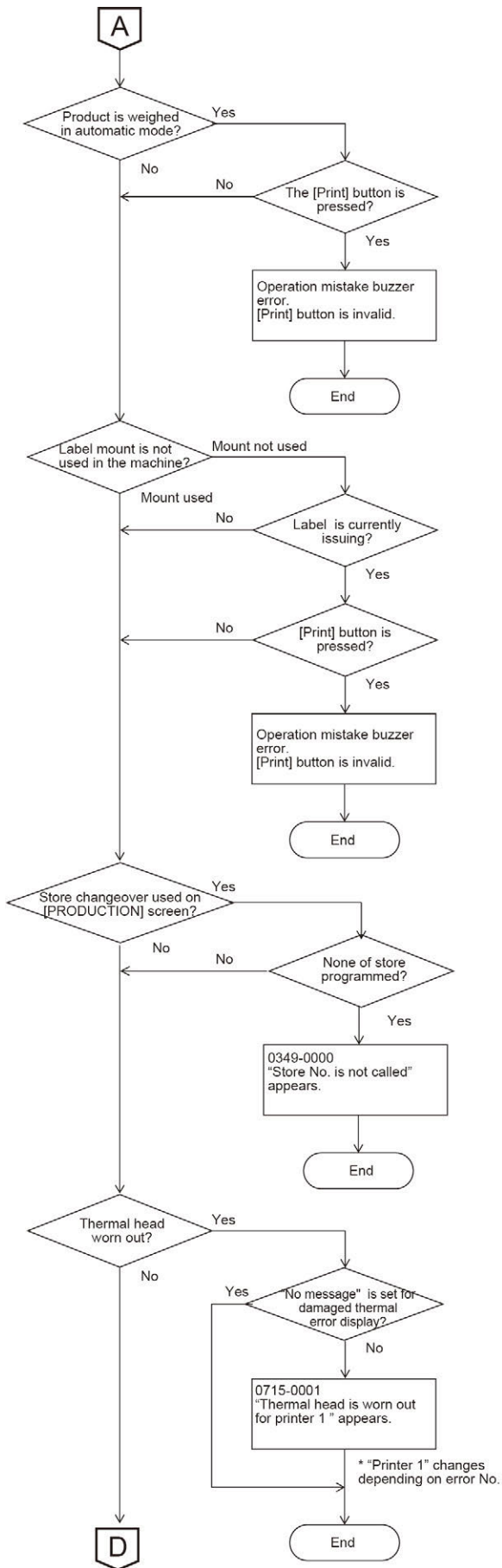

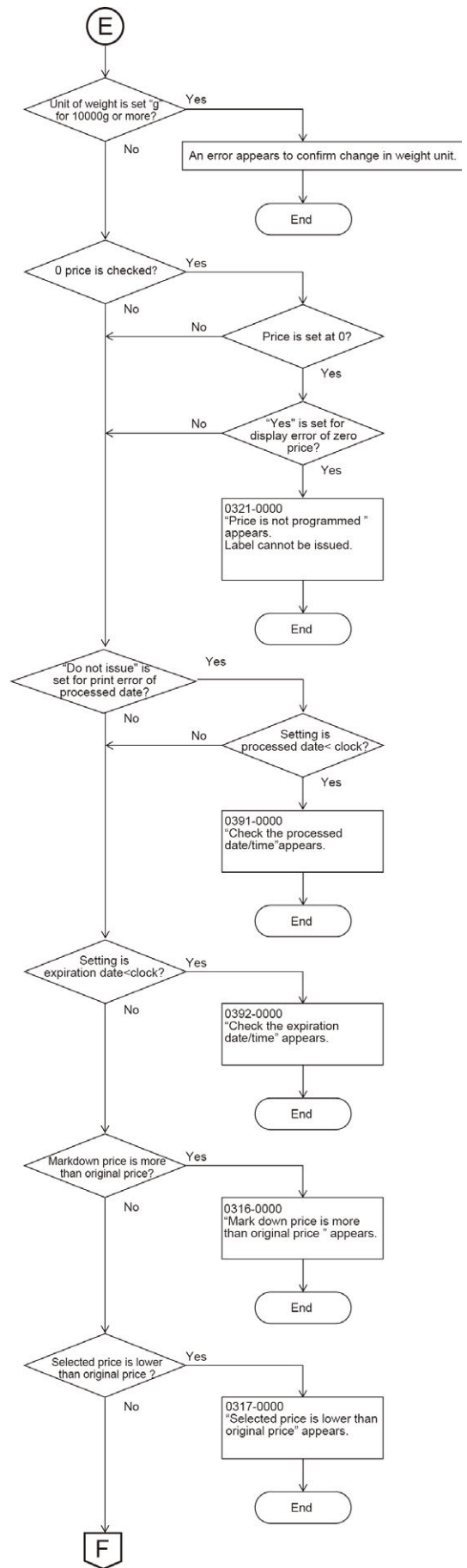
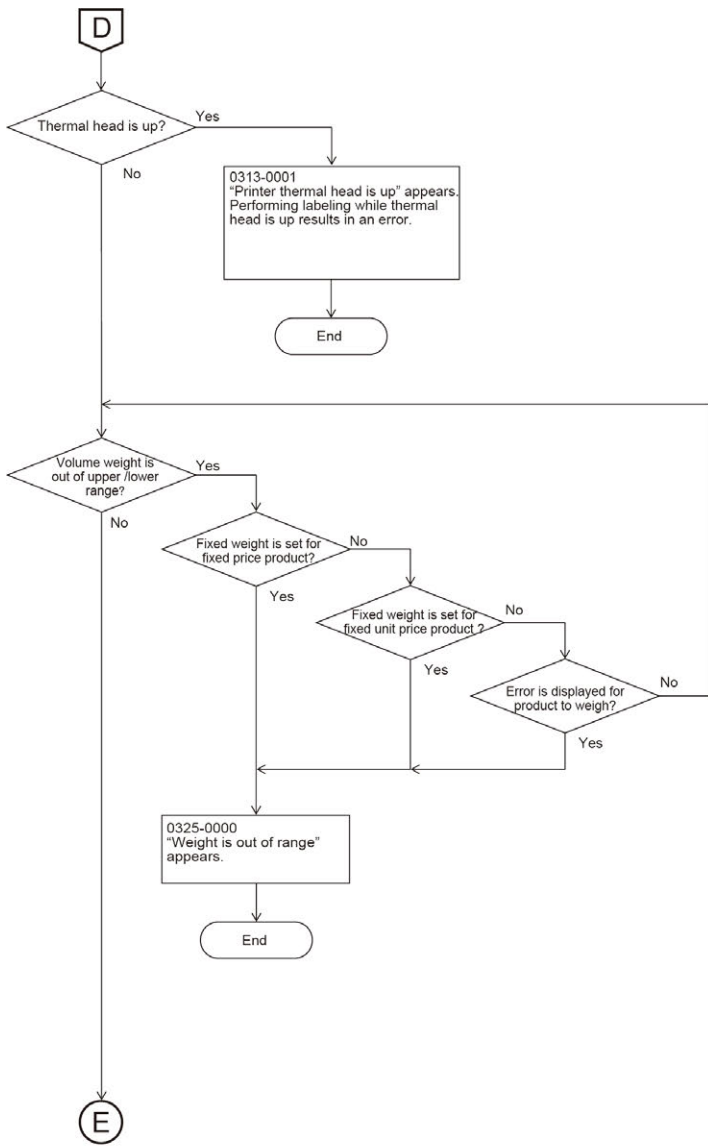

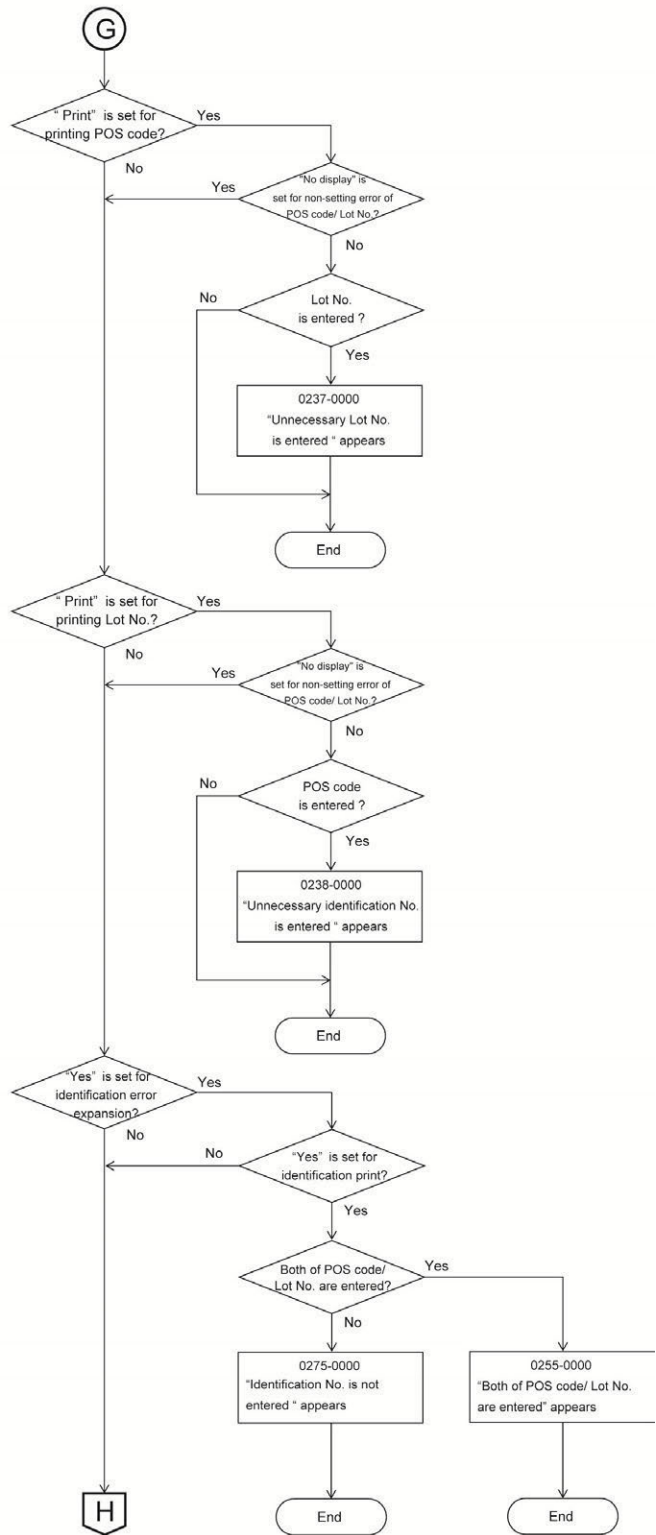
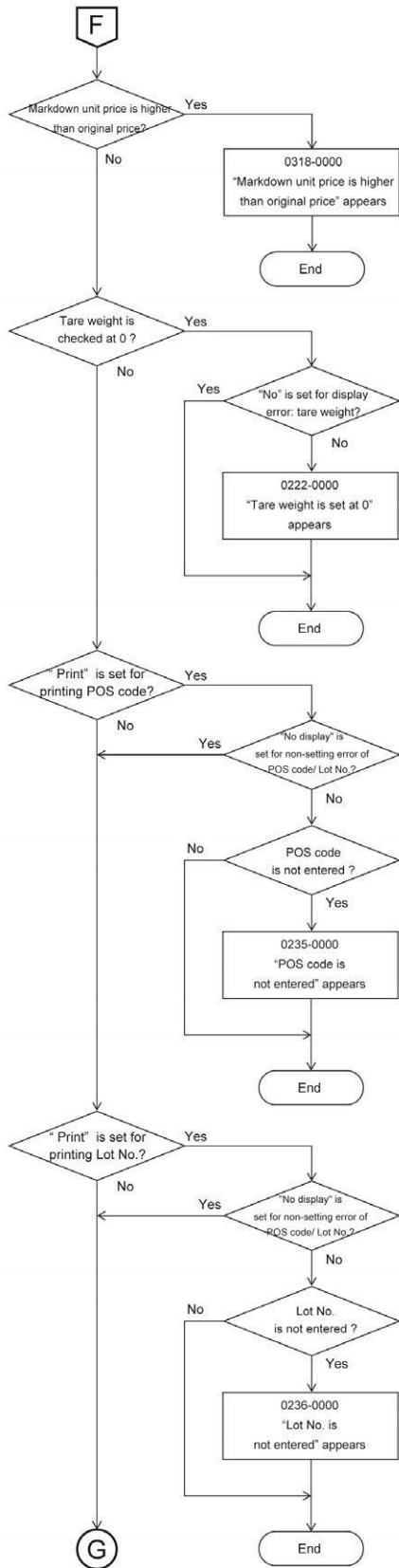

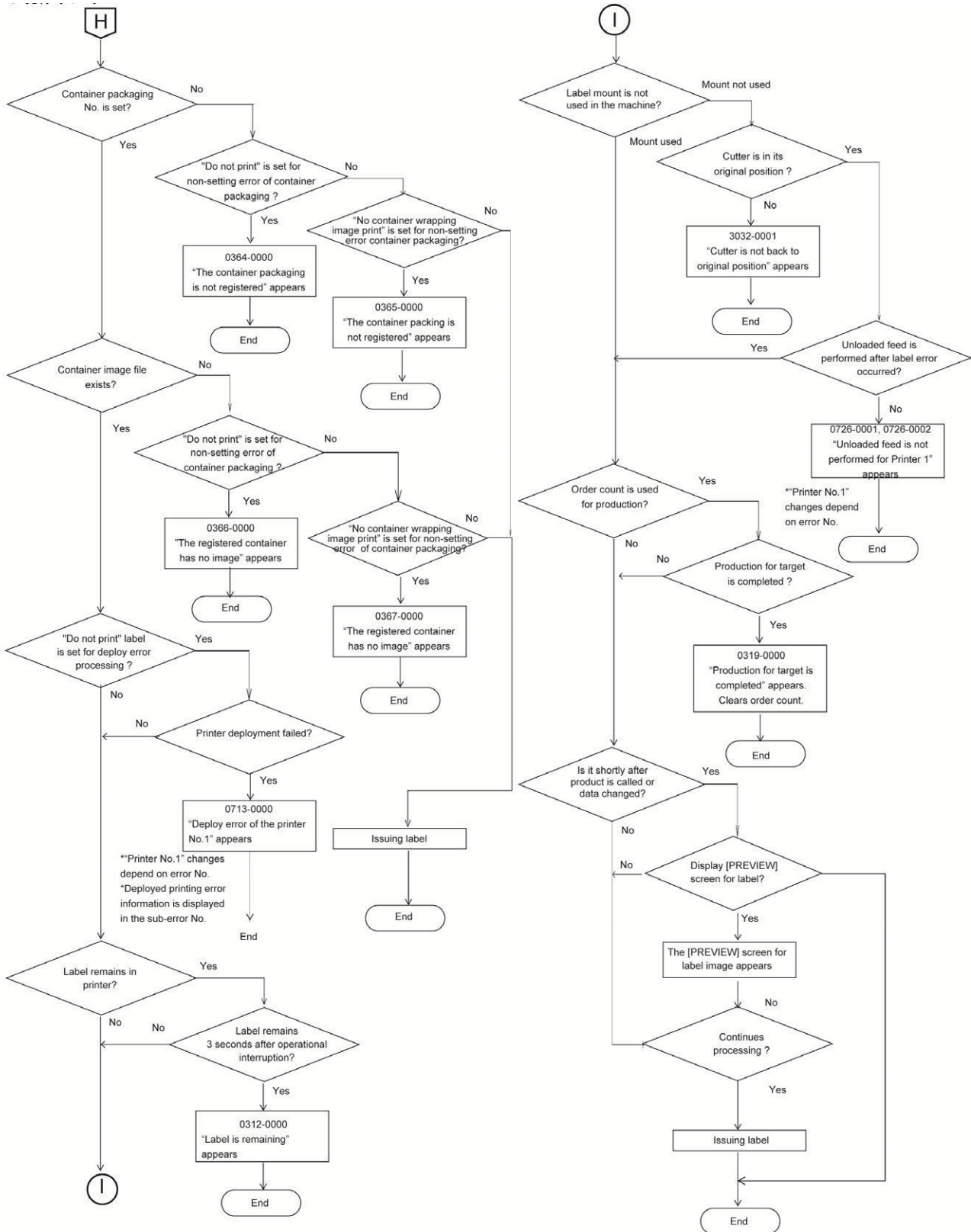

8.2 Software License

8.2.1 GNU General Public License Version 2, June 1991

Copyright (C) 1989, 1991 Free Software Foundation, Inc.
51 Franklin Street, Fifth Floor, Boston, MA 02110-1301, USA

Everyone is permitted to copy and distribute verbatim copies of this license document, but changing it is not allowed.

Preamble

The licenses for most software are designed to take away your freedom to share and change it. By contrast, the GNU General Public License is intended to guarantee your freedom to share and change free software--to make sure the software is free for all its users. This General Public License applies to most of the Free Software Foundation's software and to any other program whose authors commit to using it. (Some other Free Software Foundation software is covered by the GNU Lesser General Public License instead.) You can apply it to your programs, too.

When we speak of free software, we are referring to freedom, not price. Our General Public Licenses are designed to make sure that you have the freedom to distribute copies of free software (and charge for this service if you wish), that you receive source code or can get it if you want it, that you can change the software or use pieces of it in new free programs; and that you know you can do these things.

To protect your rights, we need to make restrictions that forbid anyone to deny you these rights or to ask you to surrender the rights. These restrictions translate to certain responsibilities for you if you distribute copies of the software, or if you modify it.

For example, if you distribute copies of such a program, whether gratis or for a fee, you must give the recipients all the rights that you have. You must make sure that they, too, receive or can get the source code. And you must show them these terms so they know their rights.

We protect your rights with two steps: (1) copyright the software, and (2) offer you this license which gives you legal permission to copy, distribute and/or modify the software.

Also, for each author's protection and ours, we want to make certain that everyone understands that there is no warranty for this free software. If the software is modified by someone else and passed on, we want its recipients to know that what they have is not the original, so that any problems introduced by others will not reflect on the original authors' reputations.

Finally, any free program is threatened constantly by software patents. We wish to avoid the danger that redistributors of a free program will individually obtain patent licenses, in effect making the program proprietary. To prevent this, we have made it clear that any patent must be licensed for everyone's free use or not licensed at all.

The precise terms and conditions for copying, distribution and modification follow.

TERMS AND CONDITIONS FOR COPYING, DISTRIBUTION AND MODIFICATION

0. This License applies to any program or other work which contains a notice placed by the copyright holder saying it may be distributed under the terms of this General Public License. The "Program", below, refers to any such program or work, and a "work based on the Program" means either the Program or any derivative work under copyright law: that is to say, a work containing the Program or a portion of it, either verbatim or with modifications and/or translated into another language. (Hereinafter, translation is included without limitation in the term "modification".) Each licensee is addressed as "you".

Activities other than copying, distribution and modification are not covered by this License; they are outside its scope. The act of running the Program is not restricted, and the output from the Program is covered only if its contents constitute a work based on the Program (independent of having been made by running the Program). Whether that is true depends on what the Program does.

1. You may copy and distribute verbatim copies of the Program's source code as you receive it, in any medium, provided that you conspicuously and appropriately publish on each copy an appropriate copyright notice and disclaimer of warranty; keep intact all the notices that refer to this License and to the absence of any warranty; and give any other recipients of the Program a copy of this License along with the Program.

You may charge a fee for the physical act of transferring a copy, and you may at your option offer warranty protection in exchange for a fee.

2. You may modify your copy or copies of the Program or any portion of it, thus forming a work based on the Program, and copy and distribute such modifications or work under the terms of Section 1 above, provided that you also meet all of these conditions:

- a) You must cause the modified files to carry prominent notices stating that you changed the files and the date of any change.
- b) You must cause any work that you distribute or publish, that in whole or in part contains or is derived from the Program or any part thereof, to be licensed as a whole at no charge to all third parties under the terms of this License.
- c) If the modified program normally reads commands interactively when run, you must cause it, when started running for such interactive use in the most ordinary way, to print or display an announcement including an appropriate copyright notice and a notice that there is no warranty (or else, saying that you provide a warranty) and that users may redistribute the program under these conditions, and telling the user how to view a copy of this License. (Exception: if the Program itself is interactive but does not normally print such an announcement, your work based on the Program is not required to print an announcement.)

These requirements apply to the modified work as a whole. If identifiable sections of that work are not derived from the Program, and can be reasonably considered independent and separate works in themselves, then this License, and its terms, do not apply to those sections when you distribute them as separate works. But when you distribute the same sections as part of a whole which is a work based on the Program, the distribution of the whole must be on the terms of this License, whose permissions for other licensees extend to the entire whole, and thus to each and every part regardless of who wrote it.

Thus, it is not the intent of this section to claim rights or contest your rights to work written entirely by you; rather, the intent is to exercise the right to control the distribution of derivative or collective works based on the Program.

In addition, mere aggregation of another work not based on the Program with the Program (or with a work based on the Program) on a volume of a storage or distribution medium does not bring the other work under the scope of this License.

3. You may copy and distribute the Program (or a work based on it, under Section 2) in object code or executable form under the terms of Sections 1 and 2 above provided that you also do one of the following:

- a) Accompany it with the complete corresponding machine-readable source code, which must be distributed under the terms of Sections 1 and 2 above on a medium customarily used for software interchange; or,
- b) Accompany it with a written offer, valid for at least three years, to give any third party, for a charge no more than your cost of physically performing source distribution, a complete machine-readable copy of the corresponding source code, to be distributed under the terms of Sections 1 and 2 above on a medium customarily used for software interchange; or,
- c) Accompany it with the information you received as to the offer to distribute corresponding source code. (This alternative is allowed only for noncommercial distribution and only if you received the program in object code or executable form with such an offer, in accord with Subsection b above.)

The source code for a work means the preferred form of the work for making modifications to it. For an executable work, complete source code means all the source code for all modules it contains, plus any associated interface definition files, plus the scripts used to control compilation and installation of the executable. However, as a special exception, the source code distributed need not include anything that is normally distributed (in either source or binary form) with the major components (compiler, kernel, and so on) of the operating system on which the executable runs, unless that component itself accompanies the executable.

If distribution of executable or object code is made by offering access to copy from a designated place, then offering equivalent access to copy the source code from the same place counts as distribution of the source code, even though third parties are not compelled to copy the source along with the object code.

4. You may not copy, modify, sublicense, or distribute the Program except as expressly provided under this License. Any attempt otherwise to copy, modify, sublicense or distribute the Program is void, and will automatically terminate your rights under this License. However, parties who have received copies, or rights, from you under this License will not have their licenses terminated so long as such parties remain in full compliance.

5. You are not required to accept this License, since you have not signed it. However, nothing else grants your permission to modify or distribute the Program or its derivative works. These actions are prohibited by law if you do not accept this License. Therefore, by modifying or distributing the Program (or any work based on the Program), you indicate your acceptance of this License to do so, and all its terms and conditions for copying, distributing or modifying the Program or works based on it.

6. Each time you redistribute the Program (or any work based on the Program), the recipient automatically receives a license from the original licensor to copy, distribute or modify the Program subject to these terms and conditions. You may not impose any further restrictions on the recipients' exercise of the rights granted herein. You are not responsible for enforcing compliance by third parties to this License.

7. If, as a consequence of a court judgment or allegation of patent infringement or for any other reason (not limited to patent issues), conditions are imposed on you (whether by court order, agreement or otherwise) that contradict the conditions of this License, they do not excuse you from the conditions of this License. If you

cannot distribute so as to satisfy simultaneously your obligations under this License and any other pertinent obligations, then as a consequence you may not distribute the Program at all. For example, if a patent license would not permit royalty-free redistribution of the Program by all those who receive copies directly or indirectly through you, then the only way you could satisfy both it and this License would be to refrain entirely from distribution of the Program.

If any portion of this section is held invalid or unenforceable under any particular circumstance, the balance of the section is intended to apply and the section as a whole is intended to apply in other circumstances.

It is not the purpose of this section to induce you to infringe any patents or other property right claims or to contest validity of any such claims; this section has the sole purpose of protecting the integrity of the free software distribution system, which is implemented by public license practices. Many people have made generous contributions to the wide range of software distributed through that system in reliance on consistent application of that system; it is up to the author/donor to decide if he or she is willing to distribute software through any other system and a licensee cannot impose that choice.

This section is intended to make thoroughly clear what is believed to be a consequence of the rest of this License.

8. If the distribution and/or use of the Program is restricted in certain countries either by patents or by copyrighted interfaces, the original copyright holder who places the Program under this License may add an explicit geographical distribution limitation excluding those countries, so that distribution is permitted only in or among countries not thus excluded. In such case, this License incorporates the limitation as if written in the body of this License.

9. The Free Software Foundation may publish revised and/or new versions of the General Public License from time to time. Such new versions will be similar in spirit to the present version, but may differ in detail to address new problems or concerns.

Each version is given a distinguishing version number. If the Program specifies a version number of this License which applies to it and "any later version", you have the option of following the terms and conditions either of that version or of any later version published by the Free Software Foundation. If the Program does not specify a version number of this License, you may choose any version ever published by the Free Software Foundation.

10. If you wish to incorporate parts of the Program into other free programs whose distribution conditions are different, write to the author to ask for permission. For software which is copyrighted by the Free Software Foundation, write to the Free Software Foundation; we sometimes make exceptions for this. Our decision will be guided by the two goals of preserving the free status of all derivatives of our free software and of promoting the sharing and reuse of software generally.

NO WARRANTY

11. BECAUSE THE PROGRAM IS LICENSED FREE OF CHARGE, THERE IS NO WARRANTY FOR THE PROGRAM, TO THE EXTENT PERMITTED BY APPLICABLE LAW. EXCEPT WHEN OTHERWISE STATED IN WRITING THE COPYRIGHT HOLDERS AND/OR OTHER PARTIES PROVIDE THE PROGRAM "AS IS" WITHOUT WARRANTY OF ANY KIND, EITHER EXPRESSED OR IMPLIED, INCLUDING, BUT NOT LIMITED TO, THE IMPLIED WARRANTIES OF MERCHANTABILITY AND FITNESS FOR A PARTICULAR

PURPOSE. THE ENTIRE RISK AS TO THE QUALITY AND PERFORMANCE OF THE PROGRAM IS WITH YOU. SHOULD THE PROGRAM PROVE DEFECTIVE, YOU ASSUME THE COST OF ALL NECESSARY SERVICING, REPAIR OR CORRECTION.

12. IN NO EVENT UNLESS REQUIRED BY APPLICABLE LAW OR AGREED TO IN WRITING WILL ANY COPYRIGHT HOLDER, OR ANY OTHER PARTY WHO MAY MODIFY AND/OR REDISTRIBUTE THE PROGRAM AS PERMITTED ABOVE, BE LIABLE TO YOU FOR DAMAGES, INCLUDING ANY GENERAL, SPECIAL, INCIDENTAL OR CONSEQUENTIAL DAMAGES ARISING OUT OF THE USE OR INABILITY TO USE THE PROGRAM (INCLUDING BUT NOT LIMITED TO LOSS OF DATA OR DATA BEING RENDERED INACCURATE OR LOSSES SUSTAINED BY YOU OR THIRD PARTIES OR A FAILURE OF THE PROGRAM TO OPERATE WITH ANY OTHER PROGRAMS), EVEN IF SUCH HOLDER OR OTHER PARTY HAS BEEN ADVISED OF THE POSSIBILITY OF SUCH DAMAGES.

END OF TERMS AND CONDITIONS

How to Apply These Terms to Your New Programs

If you develop a new program, and you want it to be of the greatest possible use to the public, the best way to achieve this is to make it free software which everyone can redistribute and change under these terms.

To do so, attach the following notices to the program. It is safest to attach them to the start of each source file to most effectively convey the exclusion of warranty; and each file should have at least the "copyright" line and a pointer to where the full notice is found.

one line to give the program's name and an idea of what it does.

Copyright (C) yyyy name of author

This program is free software; you can redistribute it and/or modify it under the terms of the GNU General Public License as published by the Free Software Foundation; either version 2 of the License, or (at your option) any later version.

This program is distributed in the hope that it will be useful, but WITHOUT ANY WARRANTY; without even the implied warranty of MERCHANTABILITY or FITNESS FOR A PARTICULAR PURPOSE. See the GNU General Public License for more details.

You should have received a copy of the GNU General Public License along with this program; if not, write to the Free Software Foundation, Inc., 51 Franklin Street, Fifth Floor, Boston, MA 02110-1301, USA.

Also add information on how to contact you by electronic and paper mail.

If the program is interactive, make it output a short notice like this when it starts in an interactive mode:

Gnomovision version 69, Copyright (C) year name of author

Gnomovision comes with ABSOLUTELY NO WARRANTY; for details

type `show w'. This is free software, and you are welcome

to redistribute it under certain conditions; type `show c'

for details.

The hypothetical commands `show w' and `show c' should show the appropriate parts of the General Public License. Of course, the commands you use may be called something other than `show w' and `show c'; they could even be mouse-clicks or menu items--whatever suits your program.

You should also get your employer (if you work as a programmer) or your school, if any, to sign a "copyright disclaimer" for the program, if necessary. Here is a sample; alter the names:

Yoyodyne, Inc., hereby disclaims all copyright
interest in the program `Gnomovision'
(which makes passes at compilers) written
by James Hacker.

signature of Ty Coon, 1 April 1989

Ty Coon, President of Vice

This General Public License does not permit incorporating your program into proprietary programs. If your program is a subroutine library, you may consider it more useful to permit linking proprietary applications with the library. If this is what you want to do, use the GNU Lesser General Public License instead of this License.

8.2.2 GNU Lesser General Public License Version 2.1, February 1999

Copyright (C) 1991, 1999 Free Software Foundation, Inc.
51 Franklin Street, Fifth Floor, Boston, MA 02110-1301 USA

Everyone is permitted to copy and distribute verbatim copies of this license document, but changing it is not allowed.

[This is the first released version of the Lesser GPL. It also counts as the successor of the GNU Library Public License, version 2, hence the version number 2.1.]

Preamble

The licenses for most software are designed to take away your freedom to share and change it. By contrast, the GNU General Public Licenses are intended to guarantee your freedom to share and change free software--to make sure the software is free for all its users.

This license, the Lesser General Public License, applies to some specially designated software packages--typically libraries--of the Free Software Foundation and other authors who decide to use it. You can use it too, but we suggest you first think carefully about whether this license or the ordinary General Public License is the better strategy to use in any particular case, based on the explanations below.

When we speak of free software, we are referring to freedom of use, not price. Our General Public Licenses are designed to make sure that you have the freedom to distribute copies of free software (and charge for this service if you wish); that you receive source code or can get it if you want it; that you can change the software and use pieces of it in new free programs; and that you are informed that you can do these things.

To protect your rights, we need to make restrictions that forbid distributors to deny you these rights or to ask you to surrender these rights. These restrictions translate to certain responsibilities for you if you distribute copies of the library or if you modify it.

For example, if you distribute copies of the library, whether gratis or for a fee, you must give the recipients all the rights that we gave you. You must make sure that they, too, receive or can get the source code. If you link other code with the library, you must provide complete object files to the recipients, so that they can relink them with the library after making changes to the library and recompiling it. And you must show them these terms so they know their rights.

We protect your rights with a two-step method: (1) we copyright the library, and (2) we offer you this license, which gives you legal permission to copy, distribute and/or modify the library.

To protect each distributor, we want to make it very clear that there is no warranty for the free library. Also, if the library is modified by someone else and passed on, the recipients should know that what they have is not the original version, so that the original author's reputation will not be affected by problems that might be introduced by others.

Finally, software patents pose a constant threat to the existence of any free program. We wish to make sure that a company cannot effectively restrict the users of a free program by obtaining a restrictive license from a patent holder. Therefore, we insist that any patent license obtained for a version of the library must be

consistent with the full freedom of use specified in this license.

Most GNU software, including some libraries, is covered by the ordinary GNU General Public License. This license, the GNU Lesser General Public License, applies to certain designated libraries, and is quite different from the ordinary General Public License. We use this license for certain libraries in order to permit linking those libraries into non-free programs.

When a program is linked with a library, whether statically or using a shared library, the combination of the two is legally speaking a combined work, a derivative of the original library. The ordinary General Public License therefore permits such linking only if the entire combination fits its criteria of freedom. The Lesser General Public License permits more lax criteria for linking other code with the library.

We call this license the "Lesser" General Public License because it does Less to protect the user's freedom than the ordinary General Public License. It also provides other free software developers Less of an advantage over competing non-free programs. These disadvantages are the reason we use the ordinary General Public License for many libraries. However, the Lesser license provides advantages in certain special circumstances.

For example, on rare occasions, there may be a special need to encourage the widest possible use of a certain library, so that it becomes a de-facto standard. To achieve this, non-free programs must be allowed to use the library. A more frequent case is that a free library does the same job as widely used non-free libraries. In this case, there is little to gain by limiting the free library to free software only, so we use the Lesser General Public License.

In other cases, permission to use a particular library in non-free programs enables a greater number of people to use a large body of free software. For example, permission to use the GNU C Library in non-free programs enables many more people to use the whole GNU operating system, as well as its variant, the GNU/Linux operating system.

Although the Lesser General Public License is Less protective of the users' freedom, it does ensure that the user of a program that is linked with the Library has the freedom and the wherewithal to run that program using a modified version of the Library.

The precise terms and conditions for copying, distribution and modification follow. Pay close attention to the difference between a "work based on the library" and a "work that uses the library". The former contains code derived from the library, whereas the latter must be combined with the library in order to run.

TERMS AND CONDITIONS FOR COPYING, DISTRIBUTION AND MODIFICATION

0. This License Agreement applies to any software library or other program which contains a notice placed by the copyright holder or other authorized party saying it may be distributed under the terms of this Lesser General Public License (also called "this License"). Each licensee is addressed as "you".

A "library" means a collection of software functions and/or data prepared so as to be conveniently linked with application programs (which use some of those functions and data) to form executables.

The "Library", below, refers to any such software library or work which has been distributed under these terms. A "work based on the Library" means either the Library or any derivative work under copyright law: that is to

say, a work containing the Library or a portion of it, either verbatim or with modifications and/or translated straightforwardly into another language. (Hereinafter, translation is included without limitation in the term "modification".)

"Source code" for a work means the preferred form of the work for making modifications to it. For a library, complete source code means all the source code for all modules it contains, plus any associated interface definition files, plus the scripts used to control compilation and installation of the library.

Activities other than copying, distribution and modification are not covered by this License; they are outside its scope. The act of running a program using the Library is not restricted, and output from such a program is covered only if its contents constitute a work based on the Library (independent of the use of the Library in a tool for writing it). Whether that is true depends on what the Library does and what the program that uses the Library does.

1. You may copy and distribute verbatim copies of the Library's complete source code as you receive it, in any medium, provided that you conspicuously and appropriately publish on each copy an appropriate copyright notice and disclaimer of warranty; keep intact all the notices that refer to this License and to the absence of any warranty; and distribute a copy of this License along with the Library.

You may charge a fee for the physical act of transferring a copy, and you may at your option offer warranty protection in exchange for a fee.

2. You may modify your copy or copies of the Library or any portion of it, thus forming a work based on the Library, and copy and distribute such modifications or work under the terms of Section 1 above, provided that you also meet all of these conditions:

- a) The modified work must itself be a software library.
- b) You must cause the files modified to carry prominent notices stating that you changed the files and the date of any change.
- c) You must cause the whole of the work to be licensed at no charge to all third parties under the terms of this License.
- d) If a facility in the modified Library refers to a function or a table of data to be supplied by an application program that uses the facility, other than as an argument passed when the facility is invoked, then you must make a good faith effort to ensure that, in the event an application does not supply such function or table, the facility still operates, and performs whatever part of its purpose remains meaningful.
(For example, a function in a library to compute square roots has a purpose that is entirely well-defined independent of the application. Therefore, Subsection 2d requires that any application-supplied function or table used by this function must be optional: if the application does not supply it, the square root function must still compute square roots.)

These requirements apply to the modified work as a whole. If identifiable sections of that work are not derived from the Library, and can be reasonably considered independent and separate works in themselves, then this License, and its terms, do not apply to those sections when you distribute them as separate works. But when you distribute the same sections as part of a whole which is a work based on the Library, the distribution of the whole must be on the terms of this License, whose permissions for other licensees extend to the entire whole, and thus to each and every part regardless of who wrote it.

Thus, it is not the intent of this section to claim rights or contest your rights to work written entirely by you;

rather, the intent is to exercise the right to control the distribution of derivative or collective works based on the Library.

In addition, mere aggregation of another work not based on the Library with the Library (or with a work based on the Library) on a volume of a storage or distribution medium does not bring the other work under the scope of this License.

3. You may opt to apply the terms of the ordinary GNU General Public License instead of this License to a given copy of the Library. To do this, you must alter all the notices that refer to this License, so that they refer to the ordinary GNU General Public License, version 2, instead of to this License. (If a newer version than version 2 of the ordinary GNU General Public License has appeared, then you can specify that version instead if you wish.) Do not make any other change in these notices.

Once this change is made in a given copy, it is irreversible for that copy, so the ordinary GNU General Public License applies to all subsequent copies and derivative works made from that copy.

This option is useful when you wish to copy part of the code of the Library into a program that is not a library.

4. You may copy and distribute the Library (or a portion or derivative of it, under Section 2) in object code or executable form under the terms of Sections 1 and 2 above provided that you accompany it with the complete corresponding machine-readable source code, which must be distributed under the terms of Sections 1 and 2 above on a medium customarily used for software interchange.

If distribution of object code is made by offering access to copy from a designated place, then offering equivalent access to copy the source code from the same place satisfies the requirement to distribute the source code, even though third parties are not compelled to copy the source along with the object code.

5. A program that contains no derivative of any portion of the Library, but is designed to work with the Library by being compiled or linked with it, is called a "work that uses the Library". Such a work, in isolation, is not a derivative work of the Library, and therefore falls outside the scope of this License.

However, linking a "work that uses the Library" with the Library creates an executable that is a derivative of the Library (because it contains portions of the Library), rather than a "work that uses the library". The executable is therefore covered by this License. Section 6 states terms for distribution of such executables.

When a "work that uses the Library" uses material from a header file that is part of the Library, the object code for the work may be a derivative work of the Library even though the source code is not. Whether this is true is especially significant if the work can be linked without the Library, or if the work is itself a library. The threshold for this to be true is not precisely defined by law.

If such an object file uses only numerical parameters, data structure layouts and accessors, and small macros and small inline functions (ten lines or less in length), then the use of the object file is unrestricted, regardless of whether it is legally a derivative work. (Executables containing this object code plus portions of the Library will still fall under Section 6.)

Otherwise, if the work is a derivative of the Library, you may distribute the object code for the work under the terms of Section 6. Any executables containing that work also fall under Section 6, whether or not they are linked directly with the Library itself.

6. As an exception to the Sections above, you may also combine or link a "work that uses the Library" with the Library to produce a work containing portions of the Library, and distribute that work under terms of your choice, provided that the terms permit modification of the work for the customer's own use and reverse engineering for debugging such modifications.

You must give prominent notice with each copy of the work that the Library is used in it and that the Library and its use are covered by this License. You must supply a copy of this License. If the work during execution displays copyright notices, you must include the copyright notice for the Library among them, as well as a reference directing the user to the copy of this License. Also, you must do one of these things:

- a) Accompany the work with the complete corresponding machine-readable source code for the Library including whatever changes were used in the work (which must be distributed under Sections 1 and 2 above); and, if the work is an executable linked with the Library, with the complete machine-readable "work that uses the Library", as object code and/or source code, so that the user can modify the Library and then relink to produce a modified executable containing the modified Library. (It is understood that the user who changes the contents of definitions files in the Library will not necessarily be able to recompile the application to use the modified definitions.)
- b) Use a suitable shared library mechanism for linking with the Library. A suitable mechanism is one that (1) uses at run time a copy of the library already presents on the user's computer system, rather than copying library functions into the executable, and (2) will operate properly with a modified version of the library, if the user installs one, as long as the modified version is interface-compatible with the version that the work was made with.
- c) Accompany the work with a written offer, valid for at least three years, to give the same user the materials specified in Subsection 6a, above, for a charge no more than the cost of performing this distribution.
- d) If distribution of the work is made by offering access to copy from a designated place, offer equivalent access to copy the above specified materials from the same place.
- e) Verify that the user has already received a copy of these materials or that you have already sent this user a copy.

For an executable, the required form of the "work that uses the Library" must include any data and utility programs needed for reproducing the executable from it. However, as a special exception, the materials to be distributed need not include anything that is normally distributed (in either source or binary form) with the major components (compiler, kernel, and so on) of the operating system on which the executable runs, unless that component itself accompanies the executable.

It may happen that this requirement contradicts the license restrictions of other proprietary libraries that do not normally accompany the operating system. Such a contradiction means you cannot use both them and the Library together in an executable that you distribute.

7. You may place library facilities that are a work based on the Library side-by-side in a single library together with other library facilities not covered by this License, and distribute such a combined library, provided that the separate distribution of the work based on the Library and of the other library facilities is otherwise permitted, and provided that you do these two things:

- a) Accompany the combined library with a copy of the same work based on the Library, uncombined with any other library facilities. This must be distributed under the terms of the Sections above.
- b) Give prominent notice with the combined library of the fact that part of it is a work based on the Library, and explaining where to find the accompanying uncombined form of the same work.

8. You may not copy, modify, sublicense, link with, or distribute the Library except as expressly provided under this License. Any attempt otherwise to copy, modify, sublicense, link with, or distribute the Library is void, and will automatically terminate your rights under this License. However, parties who have received copies, or rights, from you under this License will not have their licenses terminated so long as such parties remain in full compliance.

9. You are not required to accept this License, since you have not signed it. However, nothing else grants your permission to modify or distribute the Library or its derivative works. These actions are prohibited by law if you do not accept this License. Therefore, by modifying or distributing the Library (or any work based on the Library), you indicate your acceptance of this License to do so, and all its terms and conditions for copying, distributing or modifying the Library or works based on it.

10. Each time you redistribute the Library (or any work based on the Library), the recipient automatically receives a license from the original licensor to copy, distribute, link with or modify the Library subject to these terms and conditions. You may not impose any further restrictions on the recipients' exercise of the rights granted herein. You are not responsible for enforcing compliance by third parties with this License.

11. If, as a consequence of a court judgment or allegation of patent infringement or for any other reason (not limited to patent issues), conditions are imposed on you (whether by court order, agreement or otherwise) that contradict the conditions of this License, they do not excuse you from the conditions of this License. If you cannot distribute so as to satisfy simultaneously your obligations under this License and any other pertinent obligations, then as a consequence you may not distribute the Library at all. For example, if a patent license would not permit royalty-free redistribution of the Library by all those who receive copies directly or indirectly through you, then the only way you could satisfy both it and this License would be to refrain entirely from distribution of the Library.

If any portion of this section is held invalid or unenforceable under any particular circumstance, the balance of the section is intended to apply, and the section as a whole is intended to apply in other circumstances.

It is not the purpose of this section to induce you to infringe any patents or other property right claims or to contest validity of any such claims; this section has the sole purpose of protecting the integrity of the free software distribution system which is implemented by public license practices. Many people have made generous contributions to the wide range of software distributed through that system in reliance on consistent application of that system; it is up to the author/donor to decide if he or she is willing to distribute software through any other system and a licensee cannot impose that choice.

This section is intended to make thoroughly clear what is believed to be a consequence of the rest of this License.

12. If the distribution and/or use of the Library is restricted in certain countries either by patents or by copyrighted interfaces, the original copyright holder who places the Library under this License may add an explicit geographical distribution limitation excluding those countries, so that distribution is permitted only in or among countries not thus excluded. In such case, this License incorporates the limitation as if written in the body of this License.

13. The Free Software Foundation may publish revised and/or new versions of the Lesser General Public License from time to time. Such new versions will be similar in spirit to the present version, but may differ in detail to address new problems or concerns.

Each version is given a distinguishing version number. If the Library specifies a version number of this License which applies to it and "any later version", you have the option of following the terms and conditions either of that version or of any later version published by the Free Software Foundation. If the Library does not specify a license version number, you may choose any version ever published by the Free Software Foundation.

14. If you wish to incorporate parts of the Library into other free programs whose distribution conditions are incompatible with these, write to the author to ask for permission. For software which is copyrighted by the Free Software Foundation, write to the Free Software Foundation; we sometimes make exceptions for this. Our decision will be guided by the two goals of preserving the free status of all derivatives of our free software and of promoting the sharing and reuse of software generally.

NO WARRANTY

15. BECAUSE THE LIBRARY IS LICENSED FREE OF CHARGE, THERE IS NO WARRANTY FOR THE LIBRARY, TO THE EXTENT PERMITTED BY APPLICABLE LAW. EXCEPT WHEN OTHERWISE STATED IN WRITING THE COPYRIGHT HOLDERS AND/OR OTHER PARTIES PROVIDE THE LIBRARY "AS IS" WITHOUT WARRANTY OF ANY KIND, EITHER EXPRESSED OR IMPLIED, INCLUDING, BUT NOT LIMITED TO, THE IMPLIED WARRANTIES OF MERCHANTABILITY AND FITNESS FOR A PARTICULAR PURPOSE. THE ENTIRE RISK AS TO THE QUALITY AND PERFORMANCE OF THE LIBRARY IS WITH YOU. SHOULD THE LIBRARY PROVE DEFECTIVE, YOU ASSUME THE COST OF ALL NECESSARY SERVICING, REPAIR OR CORRECTION.

16. IN NO EVENT UNLESS REQUIRED BY APPLICABLE LAW OR AGREED TO IN WRITING WILL ANY COPYRIGHT HOLDER, OR ANY OTHER PARTY WHO MAY MODIFY AND/OR REDISTRIBUTE THE LIBRARY AS PERMITTED ABOVE, BE LIABLE TO YOU FOR DAMAGES, INCLUDING ANY GENERAL, SPECIAL, INCIDENTAL OR CONSEQUENTIAL DAMAGES ARISING OUT OF THE USE OR INABILITY TO USE THE LIBRARY (INCLUDING BUT NOT LIMITED TO LOSS OF DATA OR DATA BEING RENDERED INACCURATE OR LOSSES SUSTAINED BY YOU OR THIRD PARTIES OR A FAILURE OF THE LIBRARY TO OPERATE WITH ANY OTHER SOFTWARE), EVEN IF SUCH HOLDER OR OTHER PARTY HAS BEEN ADVISED OF THE POSSIBILITY OF SUCH DAMAGES.

END OF TERMS AND CONDITIONS

How to Apply These Terms to Your New Libraries

If you develop a new library, and you want it to be of the greatest possible use to the public, we recommend making it free software that everyone can redistribute and change. You can do so by permitting redistribution under these terms (or, alternatively, under the terms of the ordinary General Public License).

To apply these terms, attach the following notices to the library. It is safest to attach them to the start of each source file to most effectively convey the exclusion of warranty; and each file should have at least the "copyright" line and a pointer to where the full notice is found.

one line to give the library's name and an idea of what it does.
Copyright (C) year name of author

This library is free software; you can redistribute it and/or modify it under the terms of the GNU Lesser

General Public License as published by the Free Software Foundation; either version 2.1 of the License, or (at your option) any later version.

This library is distributed in the hope that it will be useful, but WITHOUT ANY WARRANTY; without even the implied warranty of MERCHANTABILITY or FITNESS FOR A PARTICULAR PURPOSE. See the GNU Lesser General Public License for more details.

You should have received a copy of the GNU Lesser General Public License along with this library; if not, write to the Free Software Foundation, Inc., 51 Franklin Street, Fifth Floor, Boston, MA 02110-1301 USA.
Also add information on how to contact you by electronic and paper mail.

You should also get your employer (if you work as a programmer) or your school, if any, to sign a "copyright disclaimer" for the library, if necessary. Here is a sample; alter the names:

Yoyodyne, Inc., hereby disclaims all copyright interest in the library `Frob' (a library for tweaking knobs) written by James Random Hacker.

signature of Ty Coon, 1 April 1990
Ty Coon, President of Vice
That's all there is to it!

8.3 Wiring Diagrams

8.3.1 PAGE 1

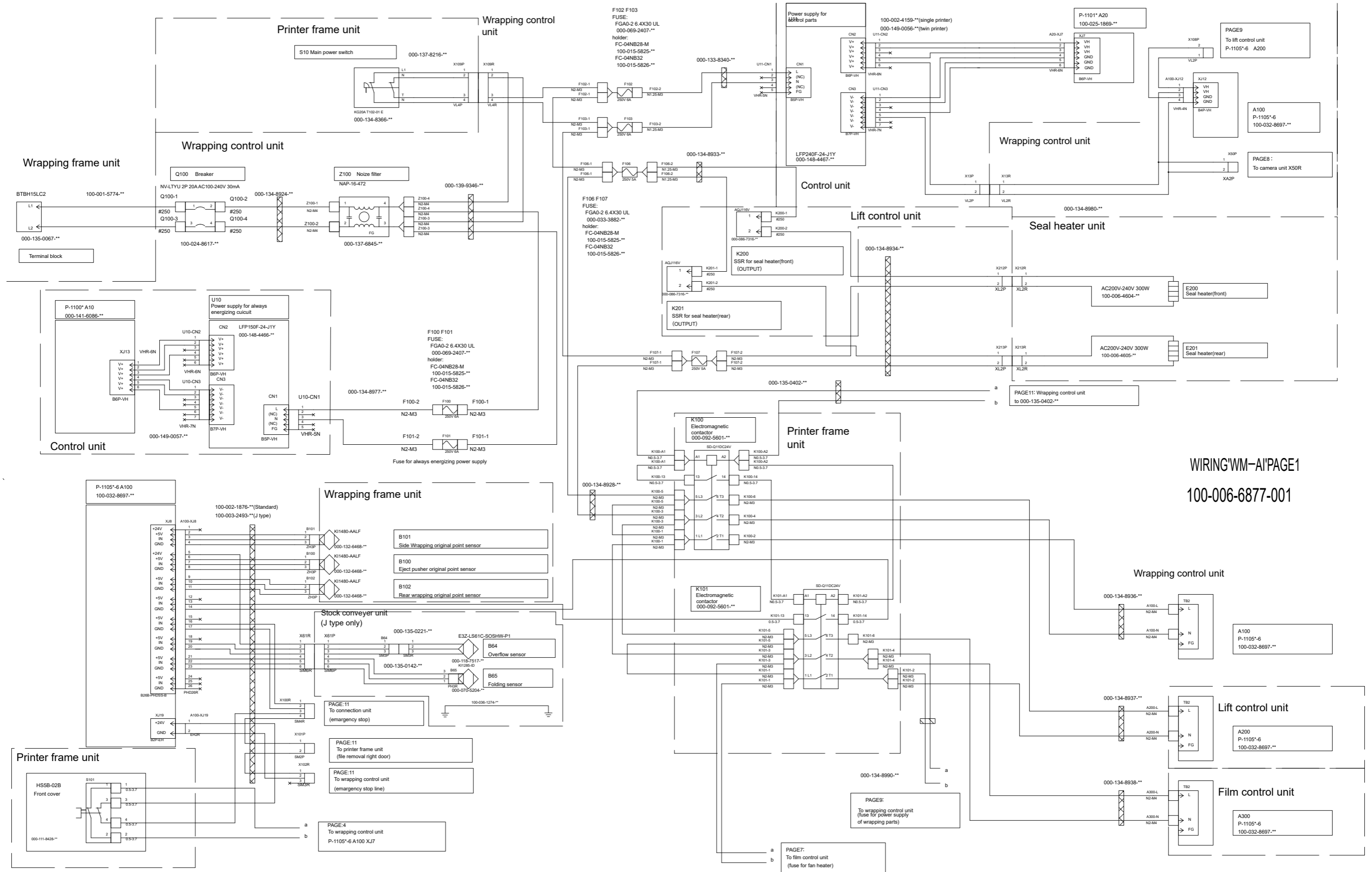

WIRING'WM-AI/PAGE1
100-006-6877-001

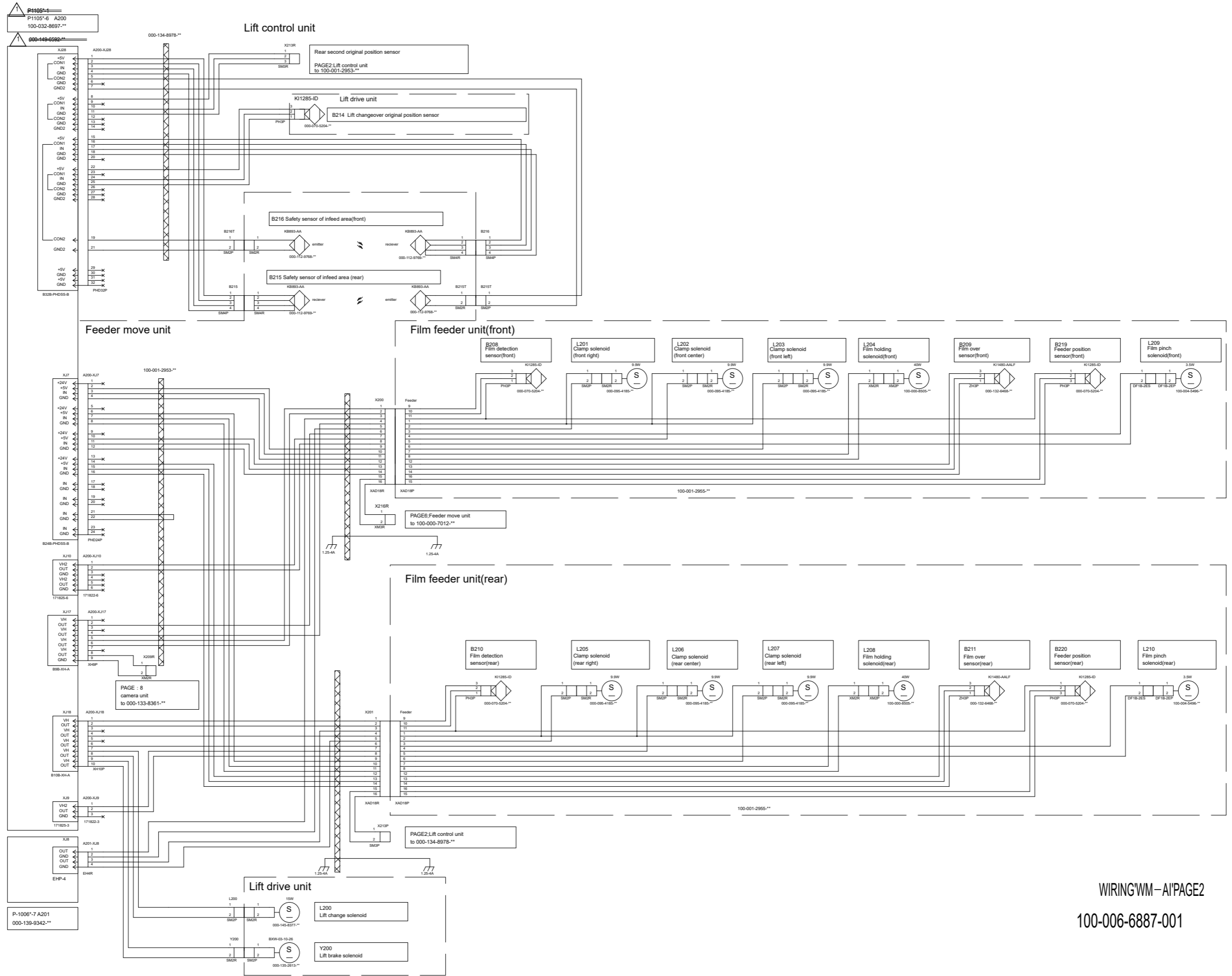

WIRINGWM-A/PAGE2
100-006-6887-001

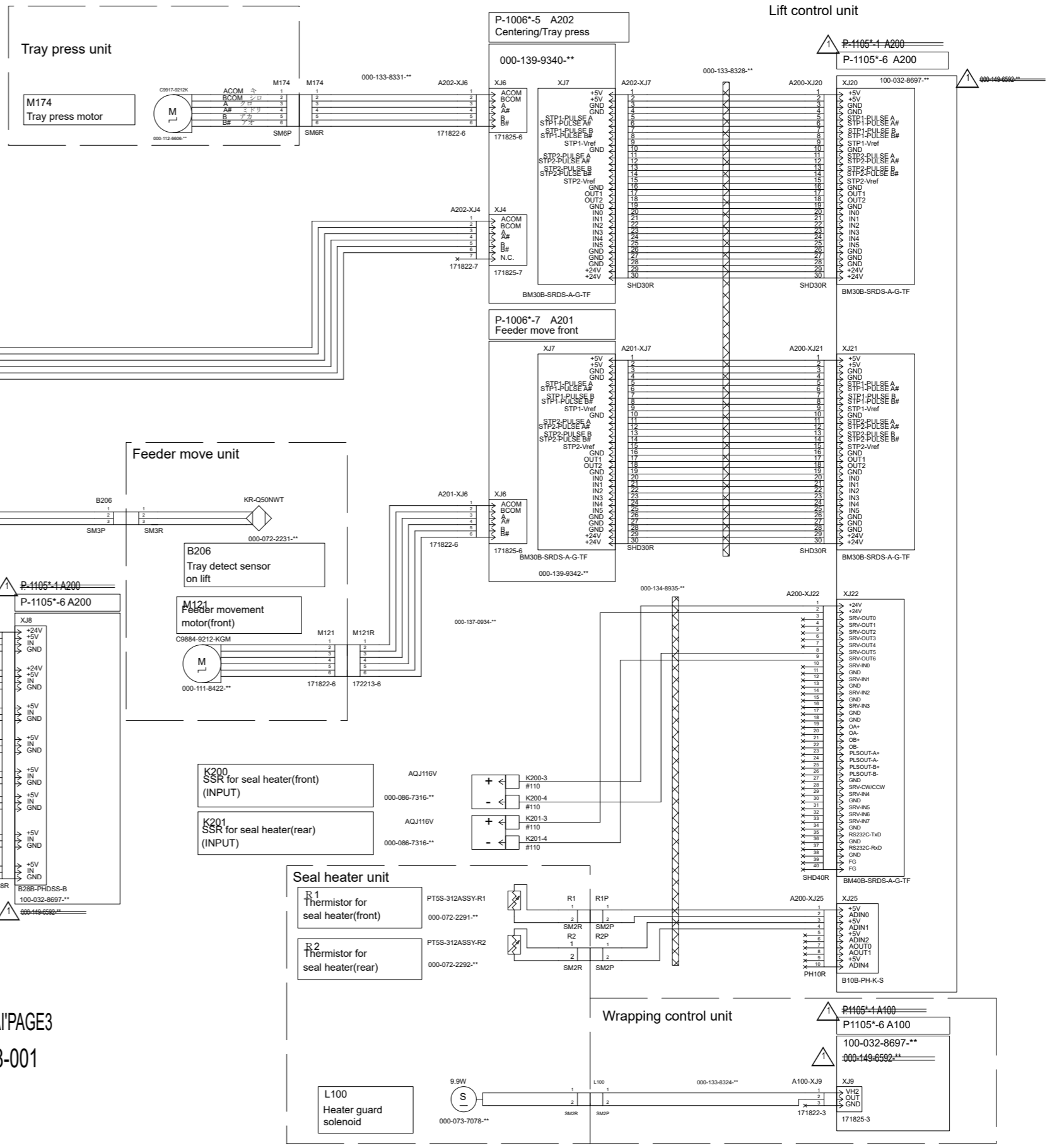

WIRING WM-AI PAGE 3
100-006-6888-001

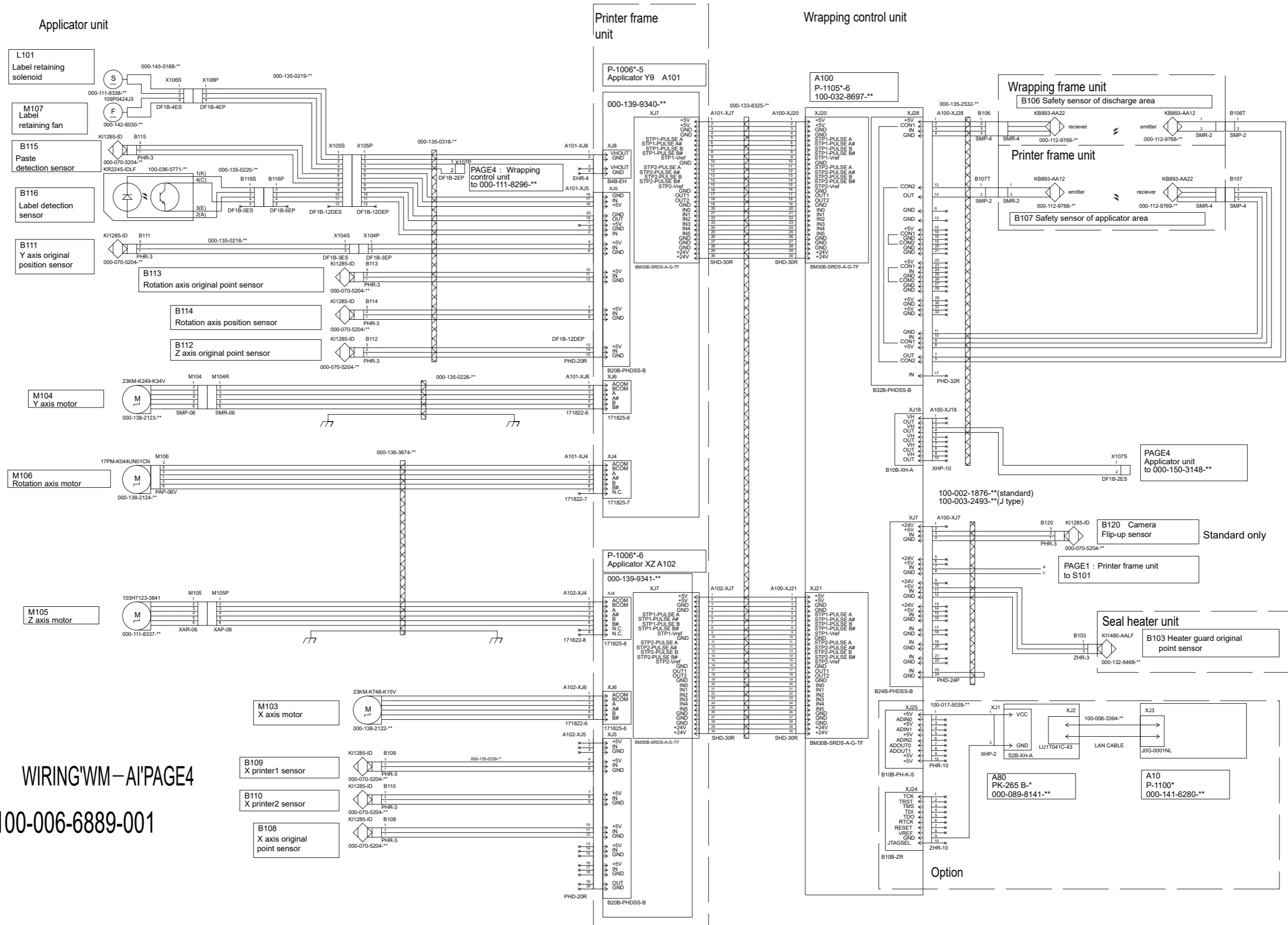

WIRING'WM-AI'PAGE4

100-006-6889-001

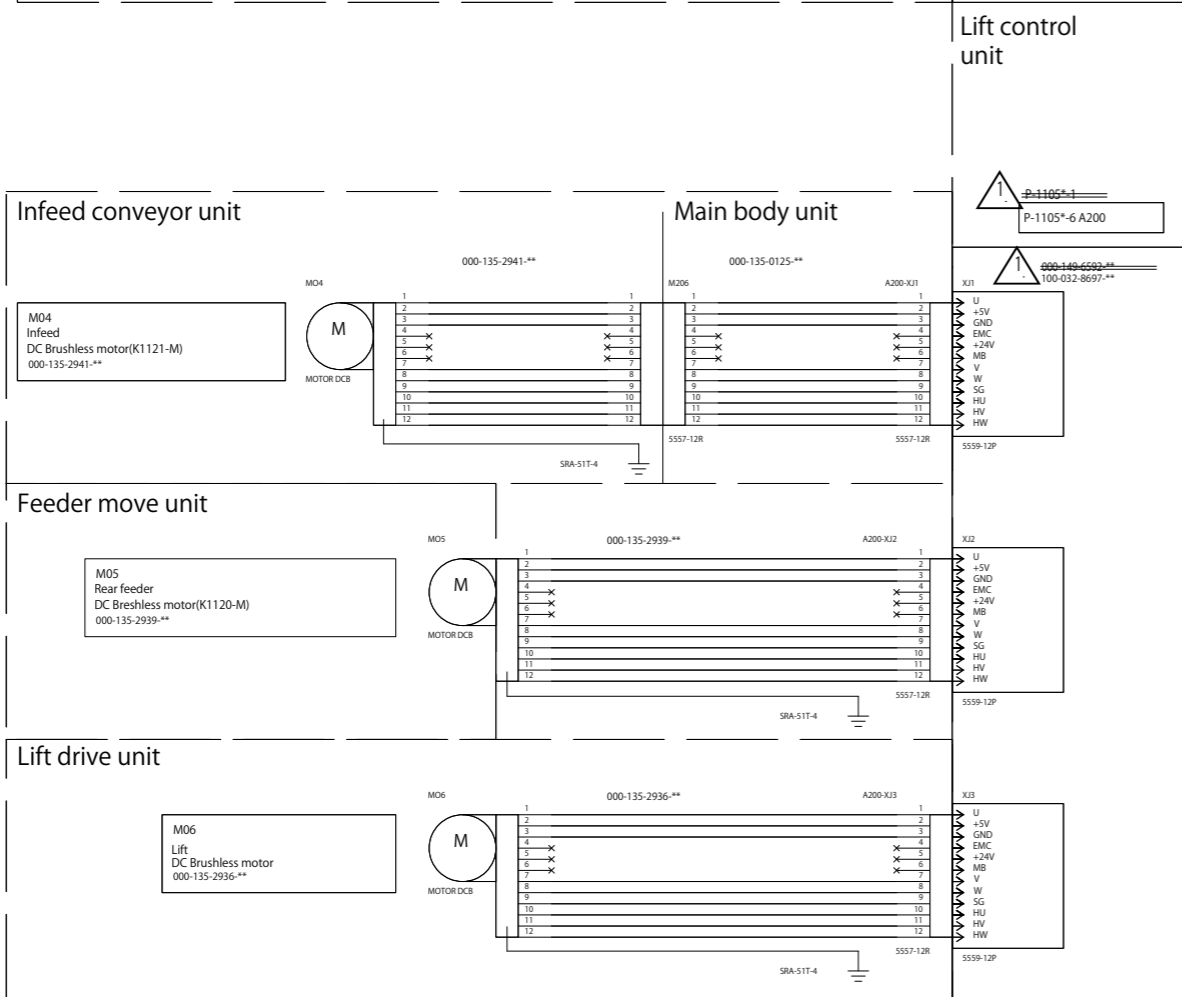
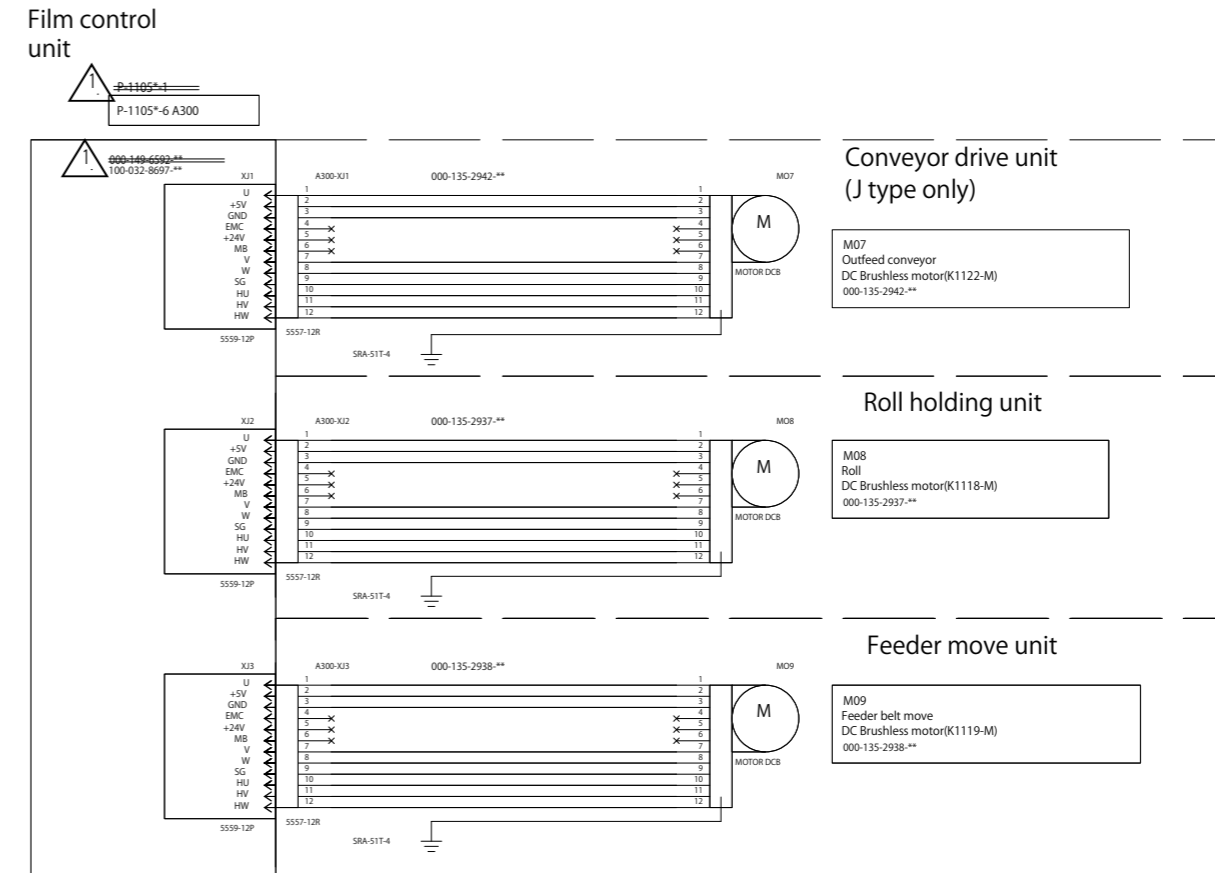
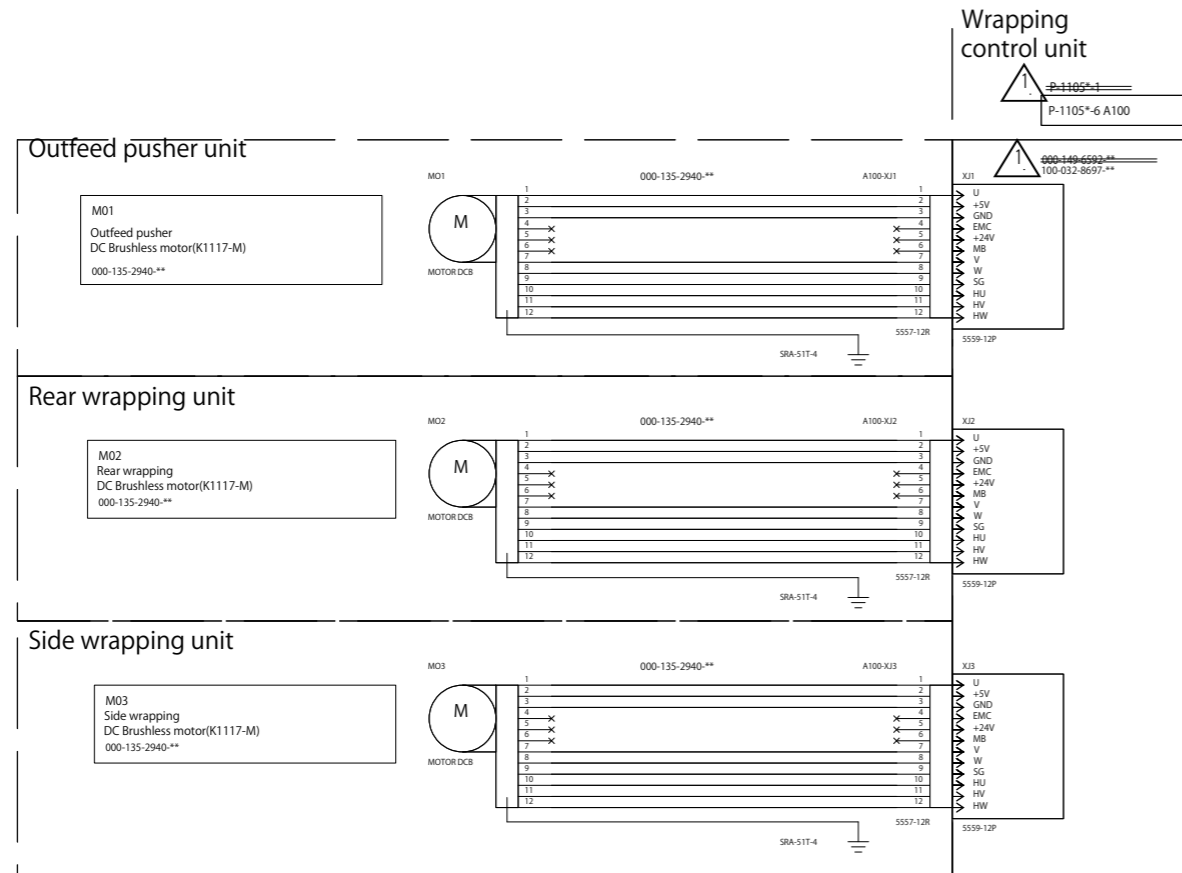

WIRING' WM-AI' PAGE5
100-006-6890-001

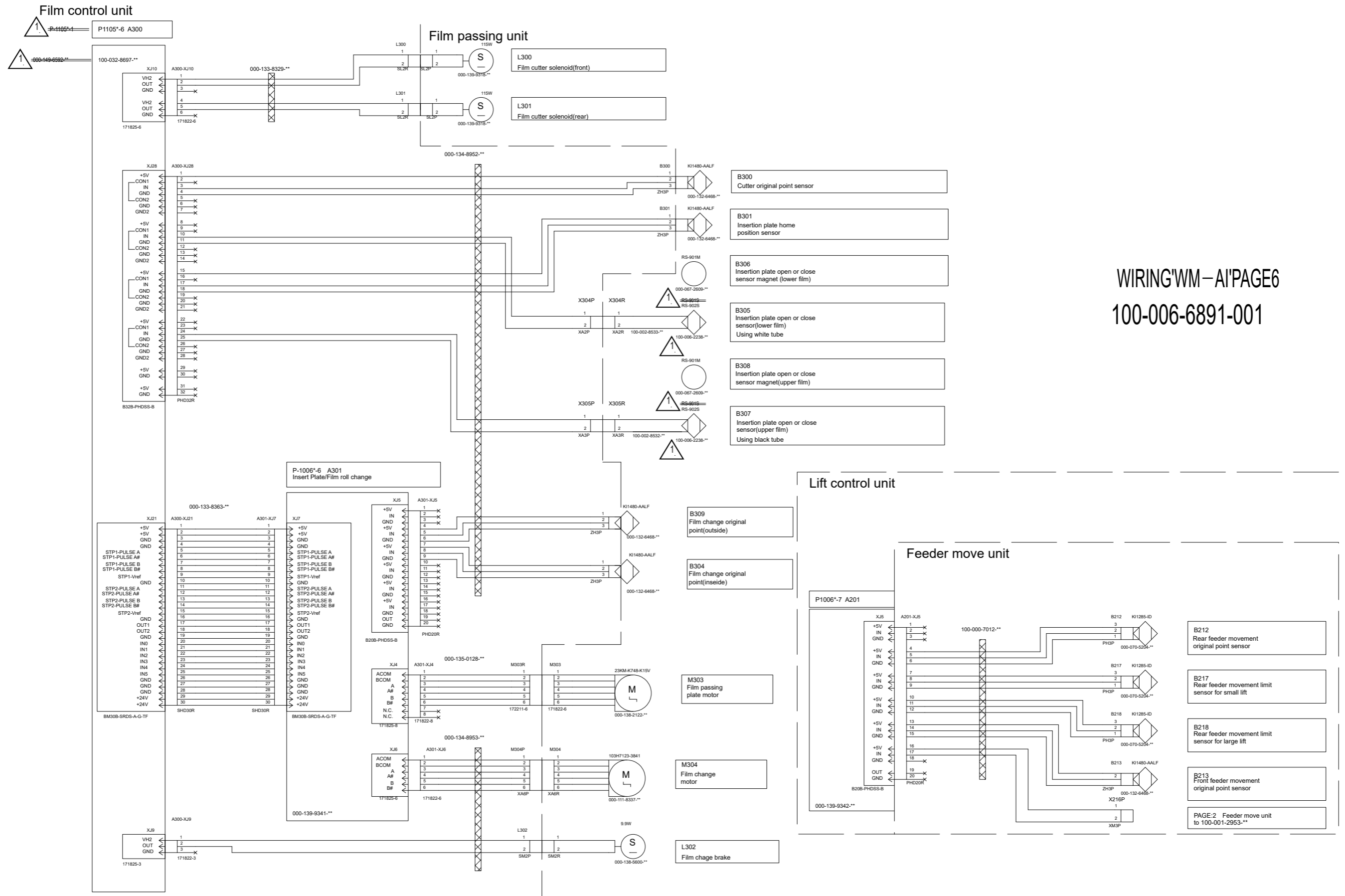

WIRING'WM-AI'PAGE6
100-006-6891-001

PAGE:2 Feeder move unit to 100-001-2953-**

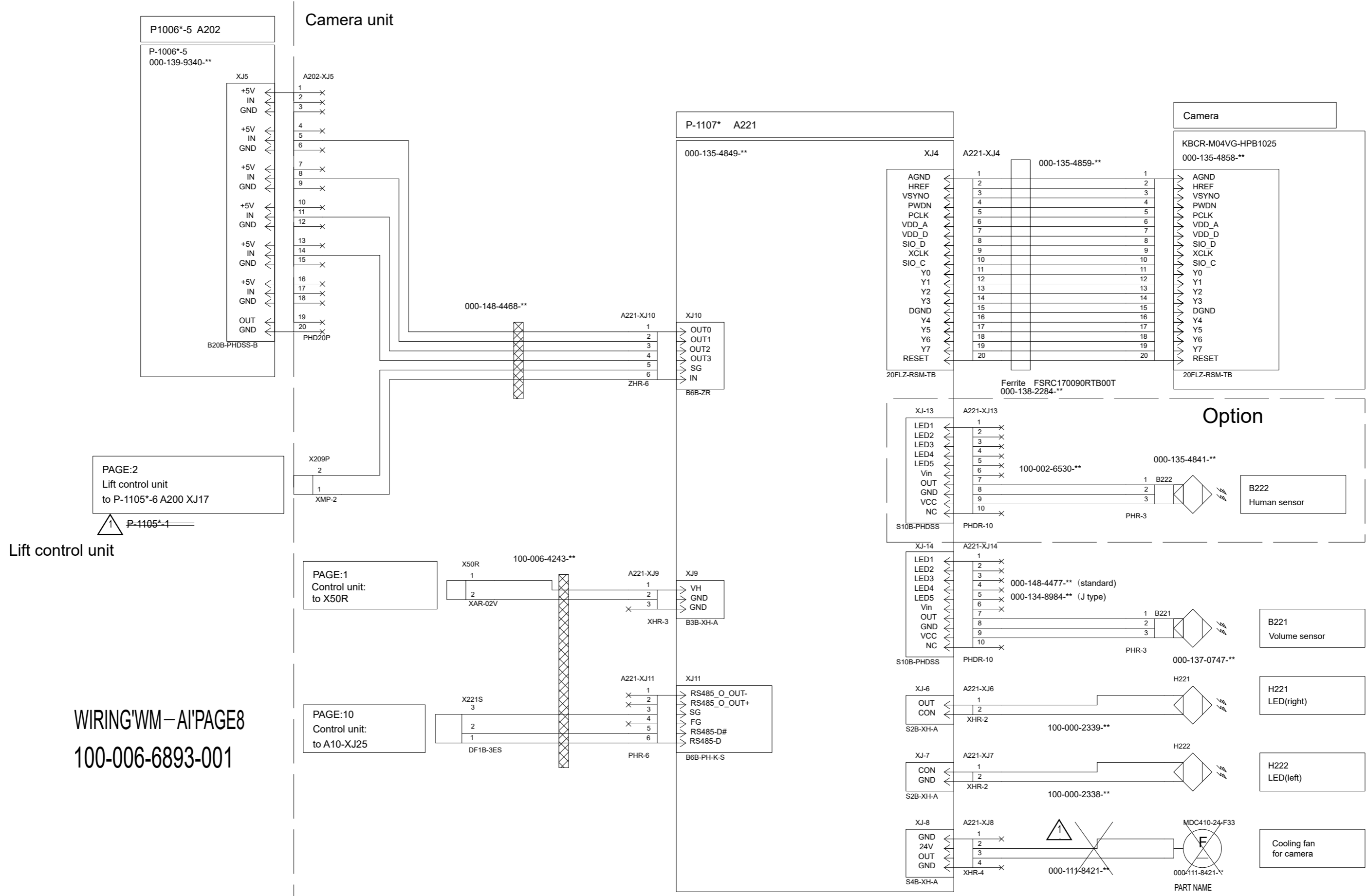

PAGE:2
Lift control unit
to P-1105*-6 A200 XJ17

Lift control unit

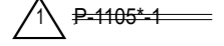

PAGE:1
Control unit:
to X50R

PAGE:10
Control unit:
to A10-XJ25

WIRING'WM-AI'PAGE8
100-006-6893-001

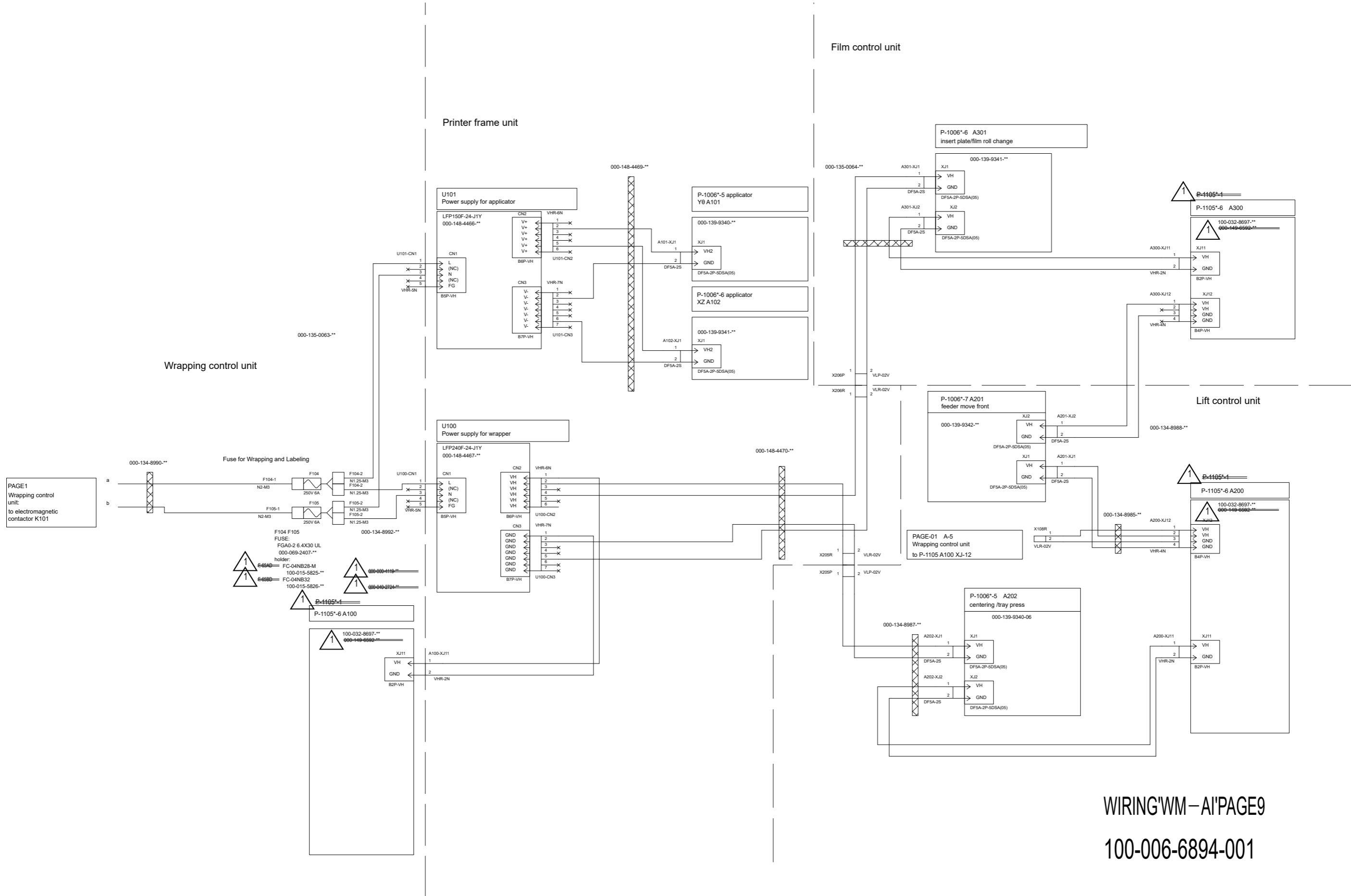

WIRING'WM-AI'PAGE9
100-006-6894-001



© Rice Lake Weighing Systems Specifications subject to change without notice.
Rice Lake Weighing Systems is an ISO 9001 registered company.

230 W. Coleman St. • Rice Lake, WI 54868 • USA
U.S. 800-472-6703 • Canada/Mexico 800-321-6703 • International 715-234-9171 • Europe +31 (0)26 472 1319