

# WE503D

*Dynamic Integrator for Belt Scales, Screw Weighers,  
Bulkside Flowmeters and Impact Flowmeters*

*Program Version: From v3.07*

## Installation Manual



© Rice Lake Weighing Systems. All rights reserved.

Rice Lake Weighing Systems® is a registered trademark of  
Rice Lake Weighing Systems.

All other brand or product names within this publication are trademarks or  
registered trademarks of their respective companies.

All information contained within this publication is, to the best of our knowledge, complete and  
accurate at the time of publication. Rice Lake Weighing Systems reserves the right to make  
changes to the technology, features, specifications and design of the equipment without notice.

The most current version of this publication, software, firmware and all other product  
updates can be found on our website:

[www.ricelake.com](http://www.ricelake.com)

# Revision History

---

This section tracks and describes manual revisions for awareness of major updates.

Revision	Date	Description
B	November 14, 2022	Established revision history; Updates to General Parameters, Belt Parameters, Calibration Parameters, Dosage Start Optimization Parameters, Belt function codes, Diagnostic Menu, and Connection Diagrams; firmware version 3.07

*Table i. Revision Letter History*



*Technical training seminars are available through Rice Lake Weighing Systems. Course descriptions and dates can be viewed at [www.ricelake.com/training](http://www.ricelake.com/training) or obtained by calling 715-234-9171 and asking for the training department.*

# Contents

<b>1.0</b>	<b>Introduction</b>	<b>1</b>
1.1	Safety	1
1.2	Electrical Safety Advice	2
1.3	Cable Classification	3
1.3.1	Recommended Cable Distances	3
1.3.2	Maximum Cable Length	3
1.4	Earth Ground System	4
1.5	General Notes	5
1.6	Technical Features	5
1.7	Construction	5
<b>2.0</b>	<b>Definitions</b>	<b>6</b>
2.1	Weigh Length	6
2.1.1	Complete Conveyor on Load Receptor	6
2.1.2	Conveyor with 1 Roller on Load Receptor	6
2.1.3	Conveyor with 2 Adjacent Rollers on Load Receptor	6
2.1.4	Screw Feeder	7
2.2	Length per Encoder Pulse	7
2.2.1	Belt	7
2.2.2	Screw feeder	7
2.3	Belt Ratio	7
2.4	Belt Factor	8
2.5	Belt Load	8
2.6	Belt Speed	8
2.7	Add to Total	8
2.8	Flow Rate	8
2.9	Zero	8
<b>3.0</b>	<b>Setup</b>	<b>9</b>
3.1	To Enter the Setup Environment	9
3.2	Initial Settings	9
3.3	General Parameters	10
3.4	Belt Parameters	12
3.5	Calibration Parameters	13
3.5.1	Integration Filtration Values	14
3.6	Batching Parameters	14
3.7	Regulator Mode Parameters	15
3.7.1	Dosage Start Optimization	15
3.7.2	PID Regulator Parameters	15
3.7.3	Remote Target Settings	16
3.7.4	PID Flow Rate Target Correction	16
3.8	Alarm Settings	17
3.8.1	Managed Alarms	17
3.8.2	Belt Off Track	17
3.8.3	Flow Overload Error	17
3.8.4	Flow Rate Error (PID)	18
3.8.5	Flow Rate Error	18
3.8.6	Under/Over-Weight Error	18



Rice Lake continually offers web-based video training on a growing selection of product-related topics at no cost. Visit [www.ricelake.com/webinars](http://www.ricelake.com/webinars)

3.8.7	External Alarm Error	18
3.8.8	Cell Overload Error	19
3.9	Function Keys	19
3.9.1	Function Codes	19
3.10	Serial Configuration	22
3.10.1	Serial Port Configuration	22
3.10.2	Print Serial Configuration	22
3.10.3	PC Serial Configuration	23
3.10.4	AUX Serial Configuration	24
3.10.5	Ethernet Configuration	24
3.11	Diagnostics Menu	25
3.12	Printout Configuration	26
3.12.1	Printout Formats	26
3.13	Database	27
3.14	Input Text Configuration	27
3.15	Set User Access Password	27
3.16	Weight Zoom Enabling	27
3.17	Start-up Text	28
3.18	Instrument Data Backup	28
3.19	External PC Keyboard Language	28
3.20	Instrument Sound Enabling	28
3.21	Reset Buffered RAM	28
3.22	Technical Default	28
3.23	PID	29
3.24	Article Database	30
<b>4.0</b>	<b>Electrical Connections</b>	<b>31</b>
4.1	Mother Board	31
4.1.1	Serial Ports	32
4.1.2	Power Supply	32
4.1.3	Load Cell Connection (Terminal Board Connection)	32
4.1.4	Inputs (Optoisolator Photocouplers)	32
4.1.5	Photomosfet Outputs	32
4.1.6	RS232 Serial Port (RJ11 Connector)	32
4.2	I/O Expansion Board	33
4.2.1	Analog Output	33
4.2.2	Inputs (Optoisolator Photocouplers)	33
4.2.3	Photomosfet Outputs	33
4.3	Integrated Circuits Installation	34
4.4	Display Board	36
4.4.1	PC-KEYB – PC Keyboard Connector	36
4.5	Connection Diagrams	37
4.6	Dimension Drawings	39
<b>5.0</b>	<b>Setup Password</b>	<b>40</b>



Technical training seminars are available through Rice Lake Weighing Systems. Course descriptions and dates can be viewed at [www.ricelake.com/training](http://www.ricelake.com/training) or obtained by calling 715-234-9171 and asking for the training department.



*Rice Lake continually offers web-based video training on a growing selection of product-related topics at no cost. Visit [www.ricelake.com/webinars](http://www.ricelake.com/webinars)*

# 1.0 Introduction

This manual is intended for use by service technicians responsible for installing a WE503D Dynamic Integrator.



Manuals are available from Rice Lake Weighing Systems at [www.ricelake.com/manuals](http://www.ricelake.com/manuals)

Warranty information is available at [www.ricelake.com/warranties](http://www.ricelake.com/warranties)

## 1.1 Safety

### Safety Definitions:



**DANGER:** Indicates an imminently hazardous situation that, if not avoided, will result in death or serious injury. Includes hazards that are exposed when guards are removed.



**WARNING:** Indicates a potentially hazardous situation that, if not avoided, could result in serious injury or death. Includes hazards that are exposed when guards are removed.



**CAUTION:** Indicates a potentially hazardous situation that, if not avoided, could result in minor or moderate injury.



**IMPORTANT:** Indicates information about procedures that, if not observed, could result in damage to equipment or corruption to and loss of data.

### General Safety



**Do not operate or work on this equipment unless this manual has been read and all instructions are understood. Failure to follow the instructions or heed the warnings could result in injury or death. Contact any Rice Lake Weighing Systems dealer for replacement manuals.**



**WARNING:** Failure to heed could result in serious injury or death.

**Electric shock risk. Disconnect all power to the instrument before opening the enclosure.**

**Work inside the enclosure must be performed by qualified service personnel only.**

**Do not operate without the enclosure completely assembled.**

**Do not allow minors (children) or inexperienced persons to operate this unit.**

**Exercise the utmost care when performing tests and making adjustments that can actuate movable parts such as feeding devices, gates, flaps, conveyors, etc. Make absolutely sure that nobody is within reach of movable parts.**

**This unit must not be operated in a potentially explosive atmosphere. It is the sole responsibility of the user to classify the area of installation and make sure that absolutely no potentially explosive atmosphere can be present at any time.**

**For the storage of key data the terminal contains a battery on the CPU board. Risk of explosion if battery is replaced improperly. Replace only with a battery of the same type or with compatible type recommended by manufacturer. Only dispose of used batteries as indicated by the manufacturer.**

**The device uses short-circuit/over-current protection for the main supply.**

**Do not use for purposes other than weight taking.**

**Do not make alterations or modifications to the unit.**

**Do not exceed the rated specification of the unit.**

**Do not use this product if any of the components are cracked.**

**Do not remove or obscure warning labels.**

**Disconnect all power to this instrument before cleaning.**

**Do not use solvents or aggressive substances to clean the unit.**

**Do not submerge.**



**CAUTION:** Failure to heed could result in minor or moderate injury.

*If this device is used in an automatic or manual filling cycle, all users must provide a hard wired emergency stop circuit outside the device circuitry.*

*When this unit is a component of a system, the resulting system design must be reviewed by qualified personnel who are familiar with the construction and operation of all individual components in the system and the potential hazards involved.*

*This unit must be installed, serviced, and operated in strict compliance with all locally applicable safety regulations.*

*The power supply unit provides SELV voltage in accordance with EN 60950. Make sure that any peripheral device connected to the weighing terminal containing its own power supply also uses SELV voltage.*

*Input voltage of the instrument must comply with the local main power supply.*

*If the line cord with connector is used as the means to separate the instrument from the power supply, the wall outlet must be installed close to the instrument and must be easily accessible. If a permanently connected power cable is used, an easily accessible separator must be included in the power supply circuit.*

*Compliance with the following safety instruction is mandatory for UL approved units: For power supply of the WE503D use LPS and/or NEC class 2 power supply units only.*



**IMPORTANT:** Failure to heed could result could result in damage to equipment or corruption to and loss of data.

*Keep this manual for future reference.*

*The unit does not have a power switch and is operational immediately after connection to the main power supply.*

*All switch gear connected to the unit and/or installed close to it, such as relays and connectors, must be fitted with appropriate components (RC-modules, diodes) to suppress interference.*

*In order to avoid static discharge, all metallic parts of a system must be thoroughly grounded. Movable parts, such as portable scales on plastic wheels, must be grounded with earth clamps or earth leads of appropriate diameter.*

## 1.2 Electrical Safety Advice

- Main power supply is restricted to within  $\pm 10\%$  of the rated voltage.
- Electric protections (fuses etc.) are provided by the technician installing the instrument.
- Respect the recommended minimal distances that are mentioned for the various cable categories.
- The extension leads of the load cells or signal amplifiers, used for the connection of the serial ports and analogue output must be within the allowed maximum lengths.
- The extension leads of the load cells or signal amplifiers must be screened. In addition, they must be laid on their own in a raceway or metal pipe as far away as possible from the power supply cables.
- Install "RC" filters on the contact coils, on the solenoid valves and on all devices producing electric disturbances.
- If it is possible that condensation could form inside the weight transmitter it is advisable to leave the instrument powered at all times.
- Every shielded cable or not (for instance PC cable, cell cable, power supply cable) connected to the indicator should be as shorter as possible, then you have to come out of the shield the minimum length of cable, then connect to the terminal box.
- If the indicator is situated inside an electric panel, the power supply cable should be a shielded cable as shorter as possible, distant from every coil supply cable, inverter, electromotive force, etc. and in addition dedicate an uncoupled transformer in order to feed the indicator only.

## 1.3 Cable Classification

The various cables are classified depending on the transmitted signals:

### Category I

- Field bus, LAN
- Shielded data cables (RS232 ...)
- Shielded cables for analogue/digital signals < 25V (sensors, load cells...)
- Low tension power supply cables (< 60V)
- Coaxial cables

### Category II

- DC supply cables with tension > 60V and < 400V
- AC supply cables with tension > 25V and < 400V

### Category III

- Power supply cables with tension > 400V
- Telephone cables

### Category IV

- Any cable subject to lightning

### 1.3.1 Recommended Cable Distances

- When the cables are laid next to each other, these must be at the distances in the table below.
- These distances are valid if in the air; these are reduced if the raceways are separated by grounded metallic shields.
- Different category cables can cross each other (90°).

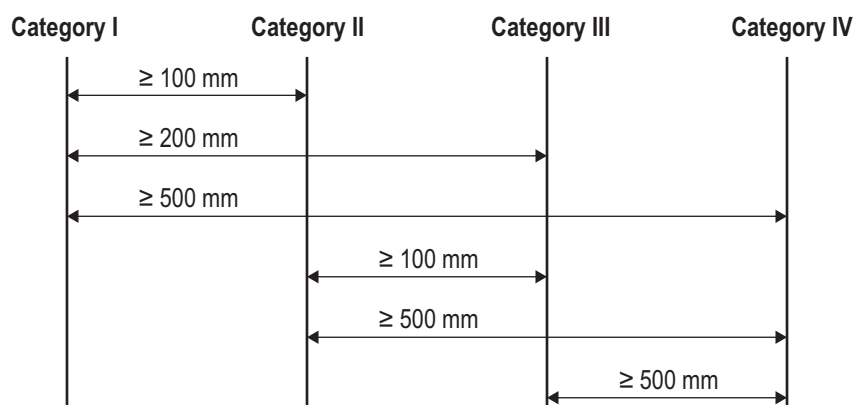

### 1.3.2 Maximum Cable Length

#### Load Cell Cable

The maximum reachable length from the line using the appropriate load cell cable is:

- 50 m with cable 6 x 0,25 mm<sup>2</sup>
- 100 m with cable 6 x 0,5 mm<sup>2</sup>

#### RS232 Cable

The maximum reachable length from the line using the RS232 cable with a maximum baud rate of 19200, is about 15 m.

#### RS485 Cable

The maximum reachable length from the line with the use of the appropriate cable for RS 485 connections, and with baud rate up to 9600, is about 1200 meters.

### Analog Output/Input Cable

The maximum length of the analogue output cable in current is:

- 100 m with cable 2 x 0,25 mm<sup>2</sup>
- 150 m with cable 2 x 0,5 mm<sup>2</sup>
- 300 m with cable 2 x 1 mm<sup>2</sup>

The maximum length of the analogue output cable in voltage is:

- 50 m with cable 2 x 0,25 mm<sup>2</sup>
- 75 m with cable 2 x 0,5 mm<sup>2</sup>
- 150 m with cable 2 x 1 mm<sup>2</sup>

## 1.4 Earth Ground System

For the right earth grounding and the optimal functioning of the system, it is necessary to connect the indicator, the load cells, the possible junction box and the weighing structure to the earth.

### Common Earth Grounding Point

Create a common earth grounding point (indicator, load cells and serial cables) near the indicator, for example the panel board earth grounding (where present) a cup clamp, and ground it through copper cables having at least a 16 mm<sup>2</sup> cross-section.

### Indicator

Connect the terminal 24 (EARTH SHIELD) and the case earth grounding to the common earth grounding point.

### Load Cells and Junction Box

The earth grounding must be done by connecting the earth grounding cables to a ground bar with cables having a cross-section of at least 16 mm<sup>2</sup> and by connecting the ground bar to a ground pole with a cable having a cross-section of at least 50 mm<sup>2</sup>.

- In the case the load cells are connected to the indicator through a junction box, it is necessary to connect the shielding of both of the cells cables and of the indicator cable to the earth ground of the junction box (refer to the junction box manual) and connect this to the earth through copper cables having at least a 16 mm<sup>2</sup> cross-section.
- If the load cells are connected directly to the indicator (without the use of the junction box), one should connect the shielding of the load cell cables to the grounding point (or earth grounding bar) inside the container.
- If the weighing system concerns large and/or outdoor structures, like a weighbridge, and the junction box is connected to the indicator in a distance that is greater than 10 m, or in the presence of noise, the cable shield must be earth grounded both in the junction box and in the indicator, and the two ground leads must be connected with an earth ground cable having a cross-section of at least 16 mm<sup>2</sup>.

### Weighing Structure

Connect the weighing structure and the possible connected structures (for example silos that release material on the weighing structure) to the earth through copper cables having at least a 16 mm<sup>2</sup> cross-section.

Furthermore it is necessary that for each cell, one connects the upper part with the lower part of the load cell through a copper braid section not less than 16 mm<sup>2</sup>; the upper part must be short-circuited with the surface of the weighing structure and the lower part must be grounded through a copper braid section not less than 16 mm<sup>2</sup>.

### Connected Serial Cables and Instruments

Ground the cable's shield both at the common earth grounding point (at the cable termination on the indicator side) and at the earth grounding of the connected instrument (at the cable termination on the connected instrument side) and ground the earth ground connection of the connected instrument using the copper cables having at least a 16 mm<sup>2</sup> cross-section.

To avoid possible side effects, the earth references of the connection and power supply cable of the indicator and of the connected instrument **must be at the same potential**.

## 1.5 General Notes

- All the grounding cables must have an adequate length, in order to obtain an overall resistance of grounding system less than 1  $\Omega$ .
- In the case the weighing system regards great and/or outdoor structures, like a weighbridge:
- The grounding connection is to be made by connecting the grounding cables to a grounding bar and the grounding bar to the grounding pole with a cable section not less than 50 mm<sup>2</sup>.
- The cable cross-section must be greater (for example 50 mm<sup>2</sup> instead of 16 mm<sup>2</sup> and 100 mm<sup>2</sup> instead of 50 mm<sup>2</sup>), because the voltage into play is greater (for example thunderbolts);
- The ground pole must be positioned at a distance of at least 10 meters from the weighbridge structure;
- One needs to open the SENSE inside the indicator in order to offset the drifts due to the increase in temperature.
- One should check and remove, if necessary, the connection between the earth and the neutral wire of the electrical installation.

## 1.6 Technical Features

WE503D is a weighing terminal for totalizing dynamic weighers, like belt scales.

It connects to one scale with analog load cells.

Power supply through the built-in power supply unit is either for 110 - 240 VAC or 12 - 30 VDC.

Cables of all external components are connected at screw terminals.

## 1.7 Construction

WE503D is incorporated in a stainless steel housing, for wall-mount, desk-top and panel-mount installation. All cable connections are made at the rear of the housing through tight cable glands.

## 2.0 Definitions

This section provides definitions to assist in the installation of a WE503D Dynamic Integrator for the service technician.

### 2.1 Weigh Length

The weigh length to insert in the configuration depends on the type of system.

#### 2.1.1 Complete Conveyor on Load Receptor

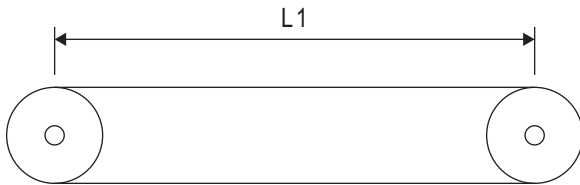

Weigh length =  $L1$

#### 2.1.2 Conveyor with 1 Roller on Load Receptor

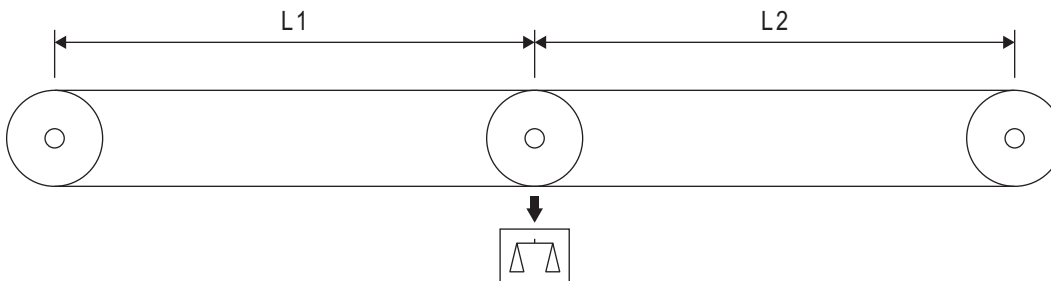

Weigh length =  $0.5 * (L1 + L2)$

#### 2.1.3 Conveyor with 2 Adjacent Rollers on Load Receptor

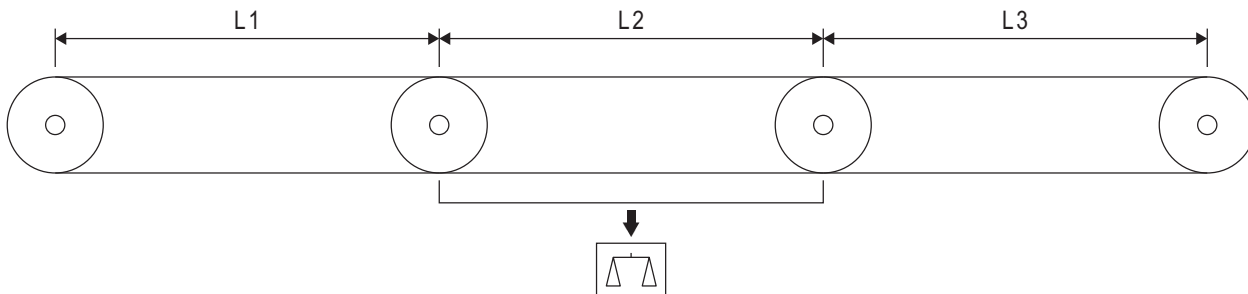

Weigh length =  $0.5 * (L1 + L3) + L2$

## 2.1.4 Screw Feeder

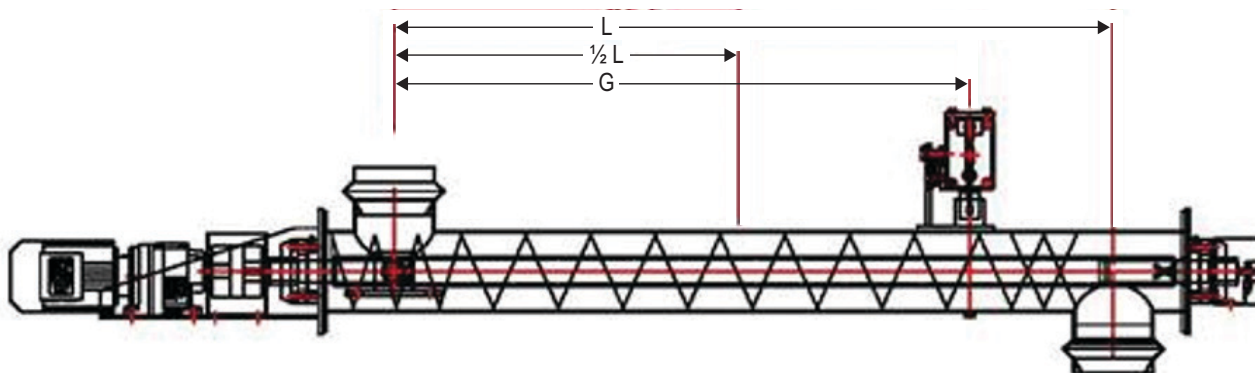

- Weigh length =  $L$
- Pivot to LC distance =  $G$
- Pivot to idler distance =  $\frac{1}{2}L$

## 2.2 Length per Encoder Pulse

### 2.2.1 Belt

Every encoder roller (of diameter  $D$ ) turn there are  $N$  pulses. The length per pulse is:

$$LPP = \pi D / N$$

### 2.2.2 Screw feeder

Every screw turn, screw with  $P_t$  pitch, there are  $N$  pulses. The length per pulse is:

$$LPP = P_t / N$$

If the calculation step is used insert:

Pulses/turn:  $N$

Diameter of encoder roller:  $P_t / \pi$

## 2.3 Belt Ratio

Belt ratio = (Pivot to LC distance) / (Pivot to idler distance) \*  $1 / \cos(\text{Belt angle})$

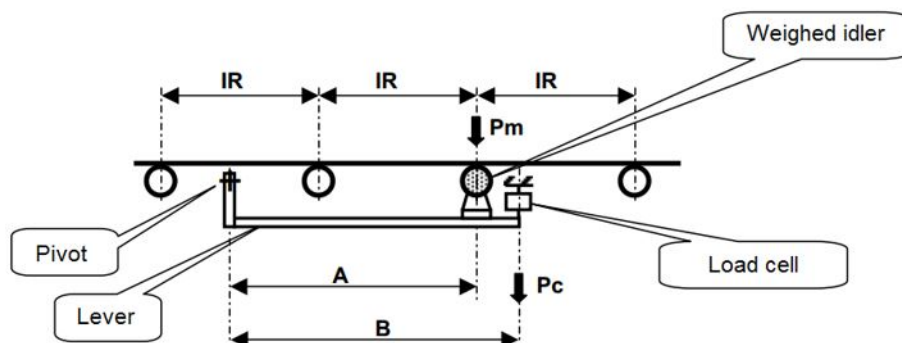

$$P_m = C_n * IR$$

$$P_c = P_m * A / B$$

## 2.4 Belt Factor

Belt factor =  $1 / (\text{Weigh length}) * (\text{Belt ratio})$

## 2.5 Belt Load

Belt load =  $((\text{LC signal}) - \text{Zero}) / (\text{Max LC signal}) * (\text{LC capacity}) * (\text{Belt factor}) * (\text{Correction factor})$

Zero: (see [Section 2.9 on page 8](#))

## 2.6 Belt Speed

Belt speed =  $(\text{Encoder frequency}) * (\text{length per pulse})$

## 2.7 Add to Total

Add to total on every encoder pulse =  $(\text{Belt load}) * (\text{Length per pulse})$

## 2.8 Flow Rate

Flow rate =  $(\text{Belt load}) * (\text{Belt speed}) * (\text{Flow correction})$

## 2.9 Zero

Load cell signal used as reference to calculate the weight on the cell. It is composed of:

Zero =  $(\text{static zero}) + (\text{zero belt}) + (\text{automatic zero belt})$

- Static zero: signal with belt structure on load cell and empty and stopped belt
- Zero belt: average difference of load cell signal from static zero during the belt zero procedure  
After the zero belt procedure is executed the automatic zero belt is set equal to zero
- Automatic zero belt: average difference of load cell signal from  $(\text{static zero}) + (\text{zero belt})$  during the automatic zero belt procedure
- When the static zero is executed, zero belt and automatic zero belt values are set equal to zero.

## 3.0 Setup

This section describes procedures to setup a WE503D Dynamic Integrator.



**WARNING**



*Risk of electrical shock.  
Risque de choc.*

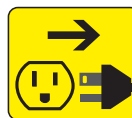

*Disconnect power before servicing.  
Débranchez l'alimentation avant l'entretien.*



**AVERTISSEMENT**



**CAUTION:** *Risk of explosion if battery is replaced by an incorrect type. Dispose of used batteries according to state and local regulations.*



**ATTENTION:** *Risque d'explosion si la batterie est remplacée par un type incorrect. Mettre au rebut les batteries usagées selon les règlements d'état et locaux.*

*Use anti-static protection for grounding and to protect components from electrostatic discharge (ESD) when working inside the enclosure. Procedures requiring work inside the enclosure must be performed by qualified service personnel only.*

*The power supply to the unit must be easily accessible.*

### 3.1 To Enter the Setup Environment

1. With the unit on, press and hold the **CLR** key for 3 seconds. The instrument restarts.
2. When the firmware version displays, press the **TARE** key once.
3. When "USER - PRESS KEY" displays, press the **TARE** key again.

See [Section 5.0 on page 40](#) for the Setup Password.

### 3.2 Initial Settings

Parameter	Description
Language	Selection of the systems language; <i>Settings: ITALIANO, <b>ENGLISH</b> (default), FRANÇAIS, DEUTSCH, ESPAÑOL</i>
System Units	Selection of the system units for weight, flow-rate and length; <i>Settings: <b>METRIC</b> (default), US</i>
Operating Mode	Selection of the operating mode; <i>Settings: BELT, <b>BULKSLIDE</b> (default)</i>

Table 3-1. Initial Settings

**Parameters are set depending on the operating mode.**

When mode **BELT** is selected:

- Encoder is enabled
- Function of input 2 is set to encoder
- Zero time is set to 60 seconds

When mode **BULKSLIDE** is selected:

- Encoder is disabled
- Function of input 2 is set to None
- Fixed speed is set to 3.00 m/s
- Zero time is set to 5 seconds
- Weigh length is set to 1000mm and parameter is not visible
- Pivot to load cell distance is set equal to 0mm and parameter is not visible
- Pivot to idler distance is set equal to 0mm and parameter is not visible
- Serial inclinometer is disabled and parameter is not visible
- Belt angle is set equal to 0° and parameter is not visible
- Test weight is set equal to zero and parameter is not visible
- Test weight delay is set equal to zero and parameter is not visible
- Air purge configuration enabled under General parameters

### 3.3 General Parameters

Parameter	Description
Batch Enable	Batch function enable; <i>Settings: NO (default), YES</i>
PID Enable	PID controller function enable; <i>Settings: NO (default), YES</i>
Pulse Weight	Insertion of the weight added to the totals between 2 pulses or between 2 pulse output level change; Value is displayed with the totals decimals and unit; <i>Enter value: 0 – 999999, 0 (default)</i>
Pulse Time Width	Insertion of the pulse time duration; If the value is equal to 0.0 seconds the output is toggled every time the <i>Pulse Weight</i> is added to the totals; <i>Enter value: 0.0s – 25.5s, 0.0s (default)</i>
Analog Input	<p>Analog input mode; <i>Settings:</i>  <b>NONE (default)</b> – No analog input  <b>SETPOINT</b> – Only if PID is enabled, sets flow-rate setpoint; sets Remote target input source to ANALOG INPUT  <b>CORRECTION</b> – Change the Correction Factor; Calculation used for Correction Factor:  <math>Correction\ Factor = (Ainput - AiZero) / (AiMax - AiZero) * 10</math>  <b>INCLINATION</b> – Change the Inclination of the belt; Calculation used for Inclination:  <math>Inclination = (Ainput - AiZero) / (AiMax - AiZero) * 60^\circ</math> (Range -60° – 60°)</p> <p>Analog input V/I input; <i>Settings: VOLT (default), CURR</i></p> <p>Analog input start/stop batch; Used analog input as RUN command to start the batch/control process if PID is enabled and analog input mode is SETPOINT; If the analog input signal is over the minimum set value the RUN command is issued to the instrument; <i>Settings: NO (default), YES</i></p> <p>Analog input max value; Maximum analog input signal in converted DAC points; This value is related to the remote flow-rate value; <i>Enter value: 0 – 32767, 0 (default)</i></p> <p>Analog input zero value; Analog input signal in converted DAC points related to the remote system zero flow-rate; <i>Enter value: 0 – 32767, 0 (default)</i></p> <p>Analog input min value; This is value is used in conjunction with the Analog input start/stop batch parameter; <i>Enter value: 0 – 32767, 0 (default)</i></p>
Analog Output Slot 1	<p>Analog output function; <i>Settings:</i>  <b>FLOW-RATE (default)</b> – Proportional to flow-rate  <b>LOAD</b> – Proportional to load  <b>PID</b> – Used to control the flow-rate (PID enabled)</p> <p>Analog output mode; <i>Settings: 4-20 mA (default), 0-20 mA, 2-10 V, 0-10 V</i>  "Set default values?"; Press enter to confirm, the calibration values will be set to the default values. Press CLR to ignore.</p> <p>Analog output calibration; <i>Available values:</i>  MIN VALUE; <i>Enter value: 0 – 65535, 12460 (default)</i>  MAX VALUE; <i>Enter value: 0 – 65535, 57950 (default)</i></p> <p>Manual belt speed; <i>Range: 0-20 mA / 0-10 V, 0 mA / V (default)</i>  Fixed analog output signal used in the following cases, if the value is different from zero:  - PID is disabled or analog output mode is set to FLOW or LOAD and the state is BATCH (neither in slow nor in flight phases) or RUN  - PID is enabled, analog output mode is set to PID and the state is STOP or BATCH in the flight phase  - Zero belt procedure  - Measurement of the length per pulse state  - Belt load phase</p>
Analog Output Slot 2	Same configuration as Analog Output Slot 1
Inputs Configuration	<p>Functions to link to the digital 8 (2+6) inputs; <i>Available values: NONE, F1–F10, Keyboard lock (LOC.IN), Off instrument (OFF), Any function linkable to keys (MNU.FUN), Run, Enable, Off track, Start, Pause, Stop, Clear P.T., Zero belt, Extern alarm, Encoder*, Article 1-5 selection (ART.1-5)**</i></p> <p>(* ) Available for Input 2 only; Encoder defaults to 2 for BELT  (**) Article is selected on input rising edge</p>
Outputs Configuration	<p>Selection of the NO/NC configuration and the functions to link the 16 (4+12) digital outputs; <i>Available values: NONE, Run / Batch active, Batch finished, System pause, Off track, &gt; Upper flow, &lt; Lower flow, Alarm, Lock, Weight impulse (totalizer pulse), Material enable, Slow flow-rate, Belt speed &gt; 0, Zero belt active, Flow-rate in dead band, Test weight, Air purge</i></p>
Air Purge Configuration	<p>Only visible when operating mode BULKSLIDE is selected; <i>Available values:</i>  Air purge interval – The interval time of activating the air purge output (min); <i>Enter value: 0 – 255, 20 (default)</i>  Air purge time – Active time of the air purge output (sec); <i>Enter value: 0 – 255, 5 (default)</i>  Air purge max flow threshold – The air purge output is only activated if the flow remains below the threshold for the air purge delay time; <i>Enter value: 0 – Max flow rate, 4 t/h (default)</i>  Air purge delay – The air purge output is only activated if the flow remains below the threshold for the air purge delay time (sec); <i>Enter value: 0 – 255, 2 (default)</i></p>

Table 3-2. General Parameters

## Diagram of Air Purge Management

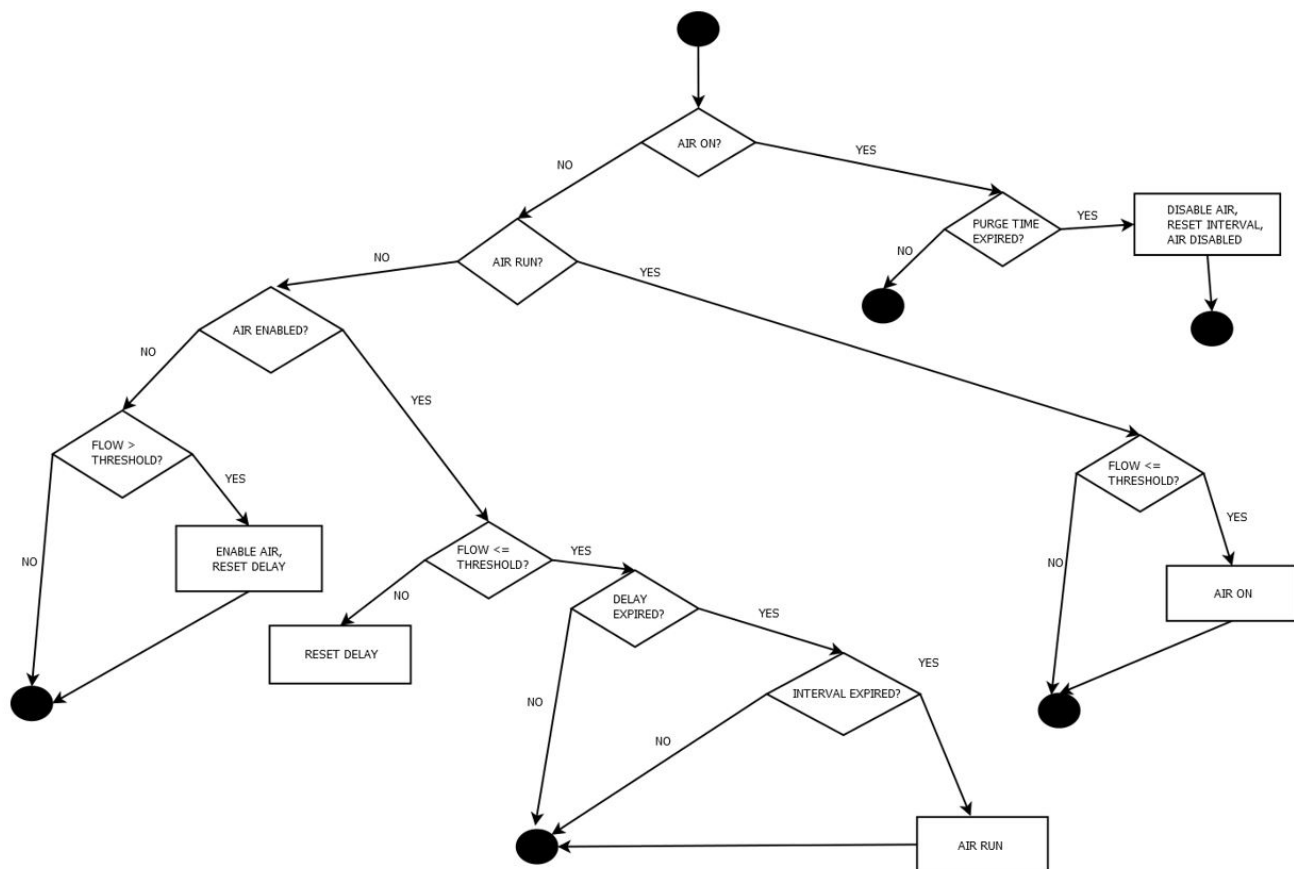

### 3.4 Belt Parameters

Parameter	Description
Total Resolution	The units displayed depends on the Unit system setting; <i>Settings: 0.1 kg/lb, 0.2 kg/lb, 0.5 kg/lb, 1 kg/lb, 2 kg/lb, 5 kg/lb, 0.01 t (default), 0.02 t, 0.05 t, 0.1 t, 0.2 t, 0.5 t, 1 t, 2 t, 5 t</i>
Flow-rate Resolution	The units displayed depends on the Unit system setting; <i>Settings: 1 kg/h / lb/h, 0.01 t/h, 0.1 t/h (default), 1 t/h</i>
Maximum Flow-rate	Maximum flow-rate value used as reference for analog output; Unit depends on the Flow-rate Resolution setting; <i>Enter value: 0 – 999999, 200.0 t/h (default)</i>
Maximum Load	Maximum belt load used as a reference for analog output; Unit depends on the Unit system setting (kg/m or lb/ft); <i>Enter value: 0 – 999999, 10 kg/m (default)</i>
Encoder Enable	Enable/disable encoder management for belt speed measurement; When enabled input 2 function should be set to Encoder; <i>Settings: NO, YES (default)</i>
Length per Pulse	Not visible if the Encoder is not enabled; Length per encoder pulse; Resolution depends on the Unit system setting (0.01 mm or 0.0001 in); <i>Enter value: 0 – 999999, 3.14 mm* (default)</i> (*) Considering 100mm as diameter for the encoder roller and 100 pulses/turn for the encoder This step has 3 sub-items: <ul style="list-style-type: none"> <li>• Insert length per pulse: Direct insertion of the pulse length.</li> <li>• Calculate value: Insert encoder's pulses/turn and Encoder's roller diameter and the length per pulse is automatically calculated by indicator.</li> <li>• Measure value: Insert the total belt length, the belt revolutions and the time to complete measuring. Press enter to start measuring, the measurement is finished after configured time elapses, press enter to finish measuring. To abort measuring press any key (except Enter).</li> </ul> Belt length resolution depends on the Unit system setting (0.001 m or 0.001 ft)
Fixed Belt Speed	Not visible if the Encoder is enabled; Belt speed considered in the flow-rate computation when the system is used without a measurement encoder; Unit depends on the Unit system setting (0.1 m/s or 0.1 ft/min); <i>Enter value: 0 – 6553.5, 0 m/s (default) or 3 m/s (BULKSLIDE)</i> Notes: If the encoder is enabled this value is automatically set equal to zero. If the encoder is disabled and fixed belt speed is set to zero, the encoder is automatically enabled.
Slow Flow-rate Fixed Speed	Not visible if the Encoder is enabled; Belt speed considered in the flow-rate computation in the slow flow phase when the system is used without a measurement encoder; Unit depends on the Unit system setting (0.1 m/s or 0.1 ft/min); <i>Enter value: 0 – 6553.5, 0 m/s (default)</i>
Dead Band	Flow-rate band in which the totals are not increased; The value is in percentage of the maximum flow-rate (%); <i>Enter value: 0 – 99.9, 2 (default)</i>
Show Flow-rate in Dead Band	Enable/disable; <i>Settings: NO (default), YES</i>
Totalize in Negative	Enable/disable the totals decrement when the flow-rate is negative, and in absolute value greater than the dead band percentage of the maximum flow-rate; <i>Settings: NO (default), YES</i>
Flow Filtering Time	Interval time considered in the average flow-rate computation (seconds); <i>Enter value: 0 – 50, 5 (default)</i>
Hourly Filtering Time	Average filter items; <i>Available values:</i> <i>N.WIN – Enter value: 0 – 32, 20 (default)</i> <i>N.MED – Enter value: 0 – N.WIN, 20 (default)</i> <i>N.PIT – Enter value: 0 – (N.WIN-2), 0 (default)</i>
Start and Stop Delay	Time delay to switch from STOP/READY state to RUN/BATCH and to switch to RUN/BATCH state to STOP/READY state (seconds); <i>Enter value: 0 – 6553.5, 0 (default)</i>

Table 3-3. Belt Parameters

### 3.5 Calibration Parameters

Parameter	Description
Load Cell Capacity	Insertion of the load cell capacity; Unit depends on the Unit system setting (kg or lb); <i>Enter value: 0 – 999999, 200 kg (default) or 20 kg (BULKSLIDE)</i>
Load Cell Sensitivity	Insertion of the load cell sensitivity (mV/V); <i>Enter value: 0.1 – 9.99999, 2 (default)</i>
Zero Scale	Insertion or acquisition of the load cell signal with empty belt (dead load); Zero Scale Insertion – Direct insertion of the dead load (mV/V); <i>Enter value: 0.1 – 9.99999, 0 (default)</i> Zero Scale Capture – Acquisition of the dead load value; Belt must be empty and running; The stored value is an average value of 2 seconds of load cell signal sampling time
Integration Filtration	Load cell signal filter; See <a href="#">Section 3.5.1 on page 14</a> for available values and their settings
Weigh Length	Not visible if Operating mode is Bulkslide (set fixed to 1000 mm); Unit depends on the Unit system setting (mm or in); Metric (mm): Resolution = 1 mm; <i>Available values: 0 – 65535, 1000 (default)</i> US (in): Resolution = 0.01 in; <i>Available values: 0 – 655.35</i>
Pivot to Load Cell Distance	Not visible if Operating mode is Bulkslide (set fixed to 0 mm); Unit depends on the Unit system setting (mm or in); Metric (mm): Resolution = 1 mm; <i>Available values: 0 – 65535, 0 (default)</i> US (in): Resolution = 0.01 in; <i>Available values: 0 – 655.35</i>
Pivot to Idler Distance	Not visible if Operating mode is Bulkslide (set fixed to 0 mm); Unit depends on the Unit system setting (mm or in); Metric (mm): Resolution = 1 mm; <i>Available values: 0 – 65535, 0 (default)</i> US (in): Resolution = 0.01 in; <i>Available values: 0 – 655.35</i>
Serial Inclinator Enable	Enable/disable specified port; <i>Settings: NO (default), AUX PORT, PRN PORT</i> Belt angle can be sent by a serial inclinometer connected to AUX or PRN port; The current supported inclinometers are single and dual axle models by Level Developments; It has to send continuously a string of the form: <i>+025.430&lt;CR&gt; or</i> <i>+025.430,-012.220&lt;CR&gt; only first part (x axle) is considered</i>
Belt Angle	Not visible if the Analog input mode is set to INCLINATION or if serial inclinometer is enabled or if Operating mode is Bulkslide (in this case it is set to 0°); <i>Enter value: 0 – 60.0, 0 (default)</i>
Correction Factor	Insertion of the add total correction factor; <i>Enter value: 0 – 9.99999, 1 (default)</i>
Zero Time	Not visible if the Encoder is enabled; Time duration of the zero belt procedure when fixed speed is used instead of encoder (in seconds); <i>Enter value: 0 – 600.00, 60 (default) or 5 (BULKSLIDE)</i>
Belt Length	Not visible if the Encoder is disabled; Total belt length used to calculate the number of pulses to read by the encoder during the zero belt procedure; Unit depends on the Unit system setting (m or ft); Metric (m): Resolution = 0.001 m; <i>Available values: 0 – 999.999, 10 (default)</i> US (ft): Resolution = 0.001 ft; <i>Available values: 0 – 999.999</i>
Belt Revolutions	Not visible if the Encoder is disabled; Number of belt revolutions to be executed during the zero belt procedure; <i>Enter value: 1 – 9, 1 (default)</i>
Zero Range	Percentage range of the maximum flow-rate within which the zero procedure is allowed to be executed; If the absolute value of the flow rate related to static zero is out of the zero range the zero belt procedure will not start (%); <i>Enter value: 0 – 99.9, 10 (default)</i>
Auto Zero Range	Percentage range of the maximum flow-rate within which the auto zero procedure will be started; If the absolute value of the current flow-rate is out of the set range the auto zero belt procedure will not start; If the absolute value of the flow-rate value during the auto zero belt procedure exceeds the set range the procedure will be aborted (%); <i>Enter value: 0 – 99.9, 0 (default) NOTE: 0% means auto zero procedure is disabled</i>
Auto Zero Limit	Percentage range of the maximum flow-rate within which the auto zero procedure will be started; If the absolute value of the current flow-rate, calculated respect to (static zero) + (zero belt) value only, is out of the set range the auto zero belt procedure will not start; If at the end of the auto zero procedure the current flow-rate, calculated respect to (static zero) + (zero belt) value only, is out of the set range the auto zero component value is not stored (%); <i>Enter value: 0 – 99.9, 0 (default) NOTE: 0% means there is no limit</i>
Test Weight Calibration	Test weight - Value of total test weight; Available values: 0 - 9999.99, 0 kg (default). Test weight delay - Delay to activate the "test weight" digital output; Available values: 0 - 6553.5, 0 s (default). Test distance - Not visible when the encoder is disabled; Distance to run the belt to complete the calibration procedure; Available values: 0 - 655.35, 0 m (default). Test time - Not visible when the encoder is enabled; Time to run the belt to complete the calibration procedure; Available values: 0 - 6553.5, 0 s (default). Material factor - Difference between Test weight calibration and Material test calibration; Available values: 0 - 9.999999, 1.000000 (default).

Table 3-4. Calibration Parameters

### 3.5.1 Integration Filtration Values

Available Values	ADC Rate (Hz)	Win	Avg	Pit
FLT 0	25	8	2	0
FLT 1	25	12	4	0
FLT 2	25	16	8	0
<b>FLT 3 (default)</b>	<b>25</b>	<b>24</b>	<b>16</b>	<b>0</b>
H.R.0	6	8	4	2
H.R.1	6	10	4	2
DYN.0	6	12	4	0
DYN.1	6	12	8	2
DOS.0	50	8	2	0
DOS.1	50	12	4	0
DOS.2	50	16	8	0
DOS.3	50	24	16	0
SLW.0	12	8	2	0
SLW.1	12	12	4	0
SLW.2	12	16	8	0
SLW.3	12	24	16	0
H.R.2	6	12	6	2
H.R.3	6	12	8	6
H.R.4	6	24	8	0
H.R.5	6	24	16	0
H.R.6	6	32	16	0
H.R.7	6	32	20	0
DYN.2	6	12	12	6
DYN.3	6	12	12	10
Custom				

Table 3-5. Integration Filtration Values

### 3.6 Batching Parameters

Not visible if the BATCH is disabled.

Parameter	Description
Dosage Target	The dosage ends when the dosage reaches the dosage target value; <i>Enter value: 0 – 999999, 0 (default)</i>
Dosage Time	The dosage ends when the dosage reaches the dosage time value; <i>Enter value: 0 – 999999, 0 (default)</i>
Low Flow-rate Weight	Threshold to enable the "slow flow" function; If PID is enabled, in dosage state, when the dosage target is missing and the dosage reached the low flow-rate weight, the "slow flow" function is enabled; If the value is 0, the function is disabled; <i>Enter value: 0 – 999999, 0 (default)</i>
Low Flow-rate	If the "slow flow" function is enabled, the analogue output is frozen at the value which obtain the low flow-rate; If the value is 0, the function is disabled; <i>Enter value: 0 – 999999, 0 (default)</i>
Weight in Flight	In flight weight, dosage ends when the dosage reached Target - flight weight; If the value is 0, the function is disabled; <i>Enter value: 0 – 999999, 0 (default)</i>
Flight Wait Time	In flight time, dosage ends when the dosage reached the dosage target and the in flight time; If the value is 0, the function is disabled; <i>Enter value: 0 – 99999, 0 (default)</i>
Jog Time	Time to activate the jog output; <i>Enter value: 0 – 99999, 0 (default)</i>

Table 3-6. Batching Parameters

## 3.7 Regulator Mode Parameters

Not visible if the PID is disabled.

### 3.7.1 Dosage Start Optimization

Parameter	Description
Belt Quick Start	Enable/disable belt quick start; <i>Settings: NO (default), YES</i> If the PID start, the analog output is set to a fixed value that allows to have a flow-rate near the target; In the start state the PID is disabled; During the flow control phase, the analog output that allows to have a flow-rate in the set tolerance is stored to be used on next start, if Quick start recalculation is enabled; If disabled in the start phase the PID target is linearly increased up to the set target flow
Quick Start After Pause	Enable/disable quick start after pause; <i>Settings: No (default), Yes</i> If enabled, after a pause or lock, the PID value is set to the last calculated PID value. If disabled, the PID starts with the PID start value (if "Belt quick start" is enabled) or from zero.
Flow Rate Reach Time	This parameter sets the flow control start phase time (in seconds); <i>Enter value: 0 – 655.35, 0 (default)</i>
Quick Start Recalculation	Enable/disable quick start recalculation; <i>Settings: NO (default), YES</i> If enabled when the target flow-rate is changed, start phase fixed analog output value is calculated in a proportional way
PID Start Value	As a percentage (%); <i>Enter value: 0.00 – 100.00, 50 (default)</i>

Table 3-7. Dosage Start Optimization Parameters

### 3.7.2 PID Regulator Parameters

Parameter	Description
Proportional K	<i>Enter value: 0 – 655.35, 3 (default)</i>
Integral Gain	<i>Enter value: 0 – 655.35, 1 (default)</i>
Differential Gain	<i>Enter value: 0 – 655.35, 0 (default)</i>
Action Interval	In seconds; <i>Enter value: 0 – 25.5, 1 (default)</i>

Table 3-8. PID Regulator Parameters

### 3.7.3 Remote Target Settings

In this menu the parameters related to the target flow-rate setting with analog input or serial string can be managed.

Parameter	Description
Remote Target Input Source	<p>Settings: <b>NONE</b> (default), <b>ANALOG INPUT</b>, <b>COM PRN</b>, <b>COM AUX</b>            Serial string format for COM PRN or COM AUX is: xxxxxxxx<code>cc</code>&lt;CR&gt;&lt;LF&gt;            x = 9 decimal, or space or +/- sign or dot (.) character            cc = Checksum sum mod 256 of the previous data expressed in ASCII hex            For test purposes the checksum is ignored when cc = "xx"            Example with remote flow-rate equal to 30.0 t/h:            String =   _   _   _   _   _   _   3   0   .   0   8   1     CR   LF              ASCII =   32   32   32   32   32   32   51   48   46   48   56   49   13   10              Checksum = (32+32+32+32+32+32+51+48+46+48) Mod 256 = 385 Mod 256 = 129 → 81 hex</p>
Remote System Flow Decimals	<p>Number of decimals of the remote flow rate value; <i>Enter value: 0 – 3, 1 (default)</i>            If Remote target input source is set to COM PRN or COM AUX this value is ignored, the decimals value is recognized by received string</p>
Remote System Flow Rate	<p>Remote flow-rate maximum value (t/h); <i>Enter value: 0 – 60000, 200 (default)</i>            Insertion decimals are those set in Remote system flow decimals; Insertion unit is the same as Flow-rate resolution</p>
% Remote Flow Rate	<p>As a percentage (%); <i>Enter value: 1 – 200, 100 (default)</i>            The target flow-rate will be set to:  <math display="block">\text{Target flow} = \text{Airatio} * (\text{Remote Flow Rate}) * (\% \text{ Remote Flow Rate})</math>           Where:  <math display="block">\text{Airatio} = (\text{Ai} - \text{Alz}) / (\text{Aimax} - \text{Alz})</math>           Ai: analog input value            Alz: analog input zero value            Aimax: analog input max value            With Remote target input source set to COM AUX or COM PRN:  <math display="block">\text{Target flow} = (\text{Received Flow}) * (\% \text{ Remote Flow Rate})</math></p>

Table 3-9. Remote Target Settings

### 3.7.4 PID Flow Rate Target Correction

These parameters are used only if Batch is enabled. These parameters allow to automatically set the target flow rate to have in the elapsed batch time the theoretical dosed material related to the target flow rate.

Parameter	Description
Flow Rate Error Correction Time	Correction flow rate checking interval (in seconds); <i>Enter value: 0 – 65535, 0 (default)</i>
Maximum % Flow Correction	The target flow rate is corrected if the value within the maximum percentage of the target flow rate (%); <i>Enter value: 0 – 10, 0 (default)</i>

Table 3-10. PID Flow Rate Target Correction Parameters

## 3.8 Alarm Settings

In this sub menu, it is possible enable/disable the managed alarms. For every type of managed alarm there are 3 common parameters to set:

- Error enabling
- Alarm delay: the alarm will start after the delay since the alarm condition started
- Lock delay: the indicator goes into locked state after the delay since the alarm condition started; If the Lock delay is set to zero the instrument lock will be disabled

### 3.8.1 Managed Alarms

Alarm	Considered	Alarm Condition	Alarm State Output Together with ALARM One	Lock State Output Together with ALARM and LOCK Ones
Belt off track	Always	Off track input active	OFF TRACK	OFF TRACK
Flow overload	Always	Flow-rate over set upper bound		
Flow rate	PID enabled	Flow-rate beyond tolerance	< LOWER FLOW or > UPPER FLOW	< LOWER FLOW or > UPPER FLOW
Under/over weight	Always	Scale weight beyond limits		
External alarm	Always	External alarm input active		
Cell overload	Always	Scale weight over load cell capacity + 9e		

Table 3-11. Managed Alarms

### 3.8.2 Belt Off Track

Off track alarm management. To use this alarm one of the digital inputs of the instrument is to be configured with the Off Track function.

Sub Menu	Available Values / Ranges	Default Value
Error Enabling	NO, YES	<b>NO</b>
Alarm Delay	0 – 6553.5 sec	<b>0 sec</b>
Lock Delay	0 – 65535.5 sec	<b>0 sec</b>

Table 3-12. Belt Off Track Menu

Alarm condition: Off Track input active

### 3.8.3 Flow Overload Error

Flow overload alarm management.

Sub Menu	Available Values / Ranges	Default Value
Error Enabling	NO, YES	<b>NO</b>
Alarm Delay	0 – 6553.5 sec	<b>0 sec</b>
Lock Delay	0 – 65535.5 sec	<b>0 sec</b>
Flow Overload %	0 – 99.9%	<b>0%</b>

Table 3-13. Flow Overload Error Menu

Alarm condition: Flow-rate, in absolute value, over the (Flow Overload %) percentage value of the maximum flow rate

### 3.8.4 Flow Rate Error (PID)

Flow rate tolerance alarm management. This alarm is managed only when PID is enabled.

Sub Menu	Available Values / Ranges	Default Value
Error Enabling	NO, YES	NO
Alarm Delay	0 – 6553.5 sec	0 sec
Lock Delay	0 – 65535.5 sec	0 sec
Max % of Flow Error +	0 – 99.9%	0%

Table 3-14. Flow Rate Error (PID) Menu

Alarm condition: Flow-rate is beyond the upper or lower bound

Flow lower bound = (Target Flow) - (Max % of Flow Error -) (Target Flow)

Flow upper bound = (Target Flow) + (Max % of Flow Error +) (Target Flow)

### 3.8.5 Flow Rate Error

Flow rate limits alarm management.

Sub Menu	Available Values / Ranges	Default Value
Error Enabling	NO, YES	NO
Alarm Delay	0 – 6553.5 sec	0 sec
Lock Delay	0 – 65535.5 sec	0 sec
Minimum Flow Rate	0 – 65535	0
Maximum Flow Rate	0 – 65535	0

Table 3-15. Flow Rate Error Menu

### 3.8.6 Under/Over-Weight Error

Weight under/over-load alarm management.

Sub Menu	Available Values / Ranges	Default Value
Error Enabling	NO, YES	NO
Alarm Delay	0 – 6553.5 sec	0 sec
Lock Delay	0 – 65535.5 sec	0 sec
Min. Weight on Load Receiver	0 – 999999	0 kg
Max. Weight on Load Receiver	0 – 999999	0 kg

Table 3-16. Under/Over-Weight Error Menu

(\*) Unit depends on the Unit system setting (kg or lb)

Alarm condition: Weight on the load receiver lower than Min. Weight or greater than Max. Weight

### 3.8.7 External Alarm Error

External input alarm management. To use this alarm one of the digital inputs of the instrument is to be configured with the Extern alarm function.

Sub Menu	Available Values / Ranges	Default Value
Error Enabling	NO, YES	NO
Alarm Delay	0 – 6553.5 sec	0 sec
Lock Delay	0 – 65535.5 sec	0 sec

Table 3-17. External Alarm Error Menu

Alarm condition: Extern Alarm input active

### 3.8.8 Cell Overload Error

Load cell overload error management.

Sub Menu	Available Values / Ranges	Default Value
Error Enabling	NO, YES	NO
Alarm Delay	0 – 6553.5 sec	0 sec
Lock Delay	0 – 65535.5 sec	0 sec

Table 3-18. Cell Overload Error Menu

## 3.9 Function Keys

It's possible to modify the function of the F1 - F10 keys, and the combination of these with the 2nd F or Fn keys (i.e. "2nd F + F1", "Fn + F2", etc...).

1. Select the desired key with F6/F7.
2. Press ENTER to modify the setting.
3. Enter the desired code through the numeric keyboard and confirm with ENTER.

#### Key Functions:

- ▼ scrolls forward inside the list of the keys.
- ▲ scrolls backward inside the list of the keys.
- F1 performs the default of the function coupling of the keys.
- F2 inserts the preamble.
- ENTER modifies the code of the function in the current key; while entering it confirms the entered code.
- 2nd F displays the list of the functions; press ENTER to select the desired function.

### 3.9.1 Function Codes

Codes can also be entered in normal operation mode, confirm with ENTER.

ID Code	Function	Default Lined to Key
100		
101		
102		
103	Printer on	
104	Simple print	F5
105	Repeat last print	2nd F + F5
106	Switch main value area data	2nd F + F8
107	Switch 2nd LCD line data	F6
108	Lock keyboard	
109	Display weight x10	
110	Set date and time	
111	Diagnostic menu	
112		
113	Free texts configuration	
114	Calculator	
115	Print and clear partial total	F8
116	Print and clear general total	F9
117		

Table 3-19. Function Codes

ID Code	Function	Default Lined to Key
118	Digital input/output and analog output diagnostic	
119	Serial communication diagnostic	
120	Custom display switch	<b>Fn + F9</b>
121	Free text 1 configuration	
122	Free text 2 configuration	
123	Free text 3 configuration	
124	Free text 4 configuration	
125	Free text 5 configuration	
126	Free text 6 configuration	
127	Free text 7 configuration	
128	Free text 8 configuration	
129	Free text 9 configuration	
130	Free text 10 configuration	
131	Clear free texts	
132	Send print format	

Table 3-19. Function Codes (Continued)

### Other Function Codes

ID Code	Function	Default Lined to Key
200	Link print format to print function	
201	Direct link 2nd print format to print function	
202	Setpoints values	
203		
204		
205		
206		
207		
208	Switch 1st LCD line (zoom disabled)	<b>F7</b>

Table 3-20. Other Function Codes

### Belt Function Codes

ID Code	Function	Default Lined to Key
300	Dynamic belt zeroing	
301	Static zeroing	
302	Enable/disable flow-rate visualization inside dead band	
303	Run belt	
304	Set target flow-rate (PID enabled)	<b>F4</b>
305	Set target dosage weight (Batch enabled)	
306	Set pulse weight	
307	Set dosage time	
308	Set slow speed weight (Batch enabled)	
309	Set slow speed flow-rate (Batch and PID enabled)	
310	Set flying weight (Batch enabled)	
311	Set flying time (Batch enabled)	

Table 3-21. Belt Function Codes

ID Code	Function	Default Lined to Key
312	Start	F1
313	Pause	F2
314	Stop	F3
315	Flow-rate graphic	
316	Articles database management	
317	Article selection in alphabetical order	
318	Print and clear article total	2nd F + F1
319	Print and clear articles totals	
320	PID settings	
321	Controller diagnostics	
322	Jog time (Batch enabled)	
323	Material test calibration (Analog input not used for correction)	
324	Set correction factor (Analog input not used for correction)	F10
325	Set flow-rate correction factor	
327	Flow-rate sampling interval for graphic	
328	Test weight calibration (Analog input not used for correction)	
329	PID P setting	
330	PID I setting	
331	PID D setting	
332	PID interval time setting	
333	Start analog output value (%)	
334	Belt factor	

Table 3-21. Belt Function Codes (Continued)

### Total Function Codes

ID Code	Function	Default Lined to Key
400	Progressive digits	
401	Ticket counter value	
402		
403	Partial total display	
404	Partial total print	
405	Partial total clear	
406	General total display	
407	General total print	
408	General total clear	
409	Article total display	
410	Article total print	
411	Article total clear	
412	Articles totals clear	
413	Clear all totals	

Table 3-22. Other Function Codes

## 3.10 Serial Configuration

The indicator is fitted with two bi-directional serial ports, both having the output in ASCII code compatible with a wide range of printers, remote displays, PCs and other devices; in the set-up it is possible to freely combine these ports to the available configurations ("ComPC", "ComPrn", and "ComAux").

Signal	AMP Connector		Terminal Board		
	COM1/COM3 (RS232)	COM2 (RS232)	COM1 (RS232)	COM2 (RS232)	COM3 (RS485)
TX	1	1	14	18	22 A(+)
RX	2	2	15	19	23 B(-)
GND	6	6	16	16	-
CTS	2	3	15	17	-

Table 3-23. Serial

### 3.10.1 Serial Port Configuration

Select the function of the serial ports.

Parameter	COM 1	COM 2	COM 3
PC.PR.AX	PC	PRN	AUX
PC.AX.PR	PC	AUX	PRN
PR.PC.AX	PRN	PC	AUX
PR.AX.PC	PRN	AUX	PC
AX.PC.PR	AUX	PC	PRN
AX.PR.PC	AUX	PRN	PC

Table 3-24. Serial Port Configuration

PC: Data transmission/reception to PC/PLC, printer, repeater, fieldbus module

PRN: Data transmission to printer, repeater

AUX: Data transmission/reception to printer, repeater, reception remote scale, barcode reader, inclinometer

### 3.10.2 Print Serial Configuration

Parameter	Description
Baud Rate	Settings: 1200, 2400, 4800, <b>9600</b> (default), 19200, 38400, 57600, 115200
Set Parity	Settings: <b>None</b> (default), Odd, Even
Set Word	Settings: 7 bit, <b>8 bit</b> (default)
Set Stop Bit	Settings: <b>1 bit</b> (default), 2 bit
Signal Synchronism	Settings: <b>No CTS</b> (default), Low, High, Emucts, Xon/Xoff
CTS Status Error	Settings: <b>Disable</b> (default), Enable
Power Supply Printer	Settings: <b>Internal</b> (default), External, External auto off
Selection Protocol	Settings: <b>Standard</b> (default), Repeater 6, Continuous, Flow rate continuous

Table 3-25. Print Serial Configuration

### 3.10.3 PC Serial Configuration

Parameter	Description
Baud Rate	Settings: 1200, 2400, 4800, <b>9600</b> (default), 19200, 38400, 57600, 115200
Set Parity	Settings: <b>None</b> (default), Odd, Even
Set Word	Settings: 7 bit, <b>8 bit</b> (default)
Set Stop Bit	Settings: <b>1 bit</b> (default), 2 bit
Signal Synchronism	Settings: <b>No CTS</b> (default), Low, High, Emucts
Address 485	Enter value: 00 – 99, <b>01</b> (default)
Selection Protocol	Settings: <b>KD Standard</b> (default), Afox type, Repeater 6, Monodirectional, Flow rate continuous, SMA, Type sysway, Modbus RTU, Fieldbus
Fieldbus Type	Only visible if fieldbus protocol is selected; Settings: <b>Profinet</b> (default), EtherCAT, CanOpen, DeviceNet, Modbus TCP, Profibus, EtherNet/IP
Fieldbus Timeout Display	Allows to enable continuous visualization of bus master timeout; Only visible if fieldbus protocol is selected; Settings: <b>No</b> (default), Yes
IP Address	The device name will be dini-(last 3 numbers of the IP Address); Only visible if Profinet or EtherNet/IP fieldbus protocol is selected; For example, if the IP address is 192.168.001.005, the name will be dini-005; Enter value: 0.0.0.0 – 255.255.255.255, <b>0.0.0.0</b> (default)
Network Mask	Only visible if Profinet or EtherNet/IP fieldbus protocol is selected; Enter value: 0.0.0.0 – 255.255.255.255, <b>255.255.255.0</b> (default)
Network Gateway	Only visible if Profinet or EtherNet/IP fieldbus protocol is selected; Enter value: 0.0.0.0 – 255.255.255.255, <b>0.0.0.0</b> (default)
Automatic Configuration	Only visible if Profinet or EtherNet/IP fieldbus protocol is selected; If Yes is selected the IP Address will be configured from the PLC; Settings: <b>No</b> (default), Yes
Node Address CanOpen	Only visible if CanOpen fieldbus protocol is selected; Enter value: 001 – 127, <b>001</b> (default)
Baud Rate CanOpen	Only visible if CanOpen fieldbus protocol is selected; Settings: <b>1 MB</b> (default), 800 KB, 500 KB, 250 KB, 125 KB, 100 KB, 50 KB, 20 KB, 10 KB
DeviceNet Mac ID	Only visible if DeviceNet fieldbus protocol is selected; Enter value: 00 – 63, <b>01</b> (default)
Baud Rate DeciveNet	Only visible if DeviceNet fieldbus protocol is selected; Settings: <b>500 KB</b> (default), 250 KB, 125 KB
Profibus Node ID	Only visible if Profibus fieldbus protocol is selected; Enter value: 000 – 126, <b>001</b> (default)
Type Transmission	Settings: <b>Upon Request</b> (default), Continuous, 485 Mode

Table 3-26. PC Serial Configuration

### 3.10.4 AUX Serial Configuration

Parameter	Description
Baud Rate	Settings: 1200, 2400, 4800, <b>9600</b> (default), 19200, 38400, 57600, 115200
Set Parity	Settings: <b>None</b> (default), Odd, Even
Set Word	Settings: 7 bit, <b>8 bit</b> (default)
Set Stop Bit	Settings: <b>1 bit</b> (default), 2 bit
Signal Synchronism	Settings: <b>No CTS</b> (default), Low, High, Emucts
Selection Protocol	Settings: <b>No Protocol</b> (default), KD Standard, Repeater 6, Flow rate continuous, Upon Request, 485 Mode

Table 3-27. AUX Serial Configuration

### 3.10.5 Ethernet Configuration

Parameter	Description
IP address type	Static, Dynamic (default)
IP address	Not visible when dynamic IP is selected. IP address configuration. 0.0.0.0 (default)
Subnet mask	Not visible when dynamic IP is selected. Subnet masks configuration. 255.255.255.0 (default)
COM port	Selection of the COM port which is connected to the Ethernet module. COM 1 (default), COM 2, COM 3
Send configuration	Send configuration to the Ethernet module and save it

Table 3-28. Ethernet Configuration

### 3.11 Diagnostics Menu

Parameter	Description
Firmware	Software version check
Weight	 <p>Dv(106): Converter point per division  0 (A): Static weight and type of load cells, (A)= Analogue and (D)= Digital  025: Data per second of the converter  S1: Checked scale, possible to select with F6/F7 keys</p>
Millivolt	Measured millivolts per scale/channel
ADC Points	A/D converter points
Display	Display version; By pressing of any key, LCD pixels turn on for a few seconds
Keyboard	By pressing a key it will show the relative number of the key; Exit by pressing one key three times
CTS Status	CTS signal of the connected printer
Battery Level	Voltage of the battery input on the motherboard
Power Supply Voltage	Voltage of the power adapter input on the motherboard
Relay Test	Testing the relay outputs by selecting the relay number with F6/F7 keys
Input Test	Status of all of the inputs
Analog Output	Enter a value between 0 and 65535 and confirm with enter, the instrument will supply the corresponding analogue value in the output
Analog Input	Value of the analogue input
Serial Ports Test	Redirect the data received by any serial port on other serial ports
Serial Number	Serial number of the instrument
Print Test	Select the format to print, if zero is selected all formats will prints sequentially
Event Log Viewer	<p>View and print all the events of the instrument;  The indicator stores the following types of event:</p> <ul style="list-style-type: none"> <li>• Metric events (calibration, equalization)</li> <li>• Battery events (turn-on, turn-off, change supply, ...)</li> <li>• Keyboard events (pressing of a keys)</li> <li>• Event to change the SETUP (default, backup, saving setup, ...)</li> <li>• Update firmware events (updating firmware)</li> <li>• Network events</li> </ul> <p>For each type are stored the last 10 events with date/time of registration; In this step is possible select which event shows and scrolls the last 10 events; By pressing the F5 key, it is possible to print this list</p>
Belt Diagnostics	<p>Belt Diagnostics:</p> <ul style="list-style-type: none"> <li>• Belt load (kg/m)</li> <li>• Belt speed (m/s)</li> <li>• Encoder pulses (puls./sec)</li> <li>• Encoder rollers (rev./min)</li> <li>• Inclination (degrees)</li> <li>• Flow rate (t/h)</li> <li>• Flow rate to static zero (t/h)</li> <li>• Flow rate to dynamic zero (t/h)</li> </ul>
PID Values Visualization	<p>PID values stored during the last dosage:</p> <ul style="list-style-type: none"> <li>• PID</li> <li>• Derivative</li> <li>• Sum</li> <li>• Error</li> </ul>
Flow Rate Related to Analog Output	<p>Visualization of the hourly flow in respect to the programmed analogue output value;  Enter a value between 0-65535, confirm with ENTER, instrument display the flow rate</p>

Table 3-29. Diagnostics Menu

Parameter	Description
Ethernet info	MAC address: xx:xx:xx:xx:xx:xx Where xx= Value in hexadecimal  IP(t): y.y.y.y/nn Where t= IP address type, static (S) or dynamic (D) nn= The number of one's in the subnet mask (example: 24 is a subnet mask of 255.255.255.0)

Table 3-29. Diagnostics Menu (Continued)

## 3.12 Printout Configuration

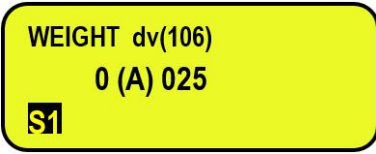
Parameter	Description
Insertion Headings	Settings: Heading 0 (txt.i0), Heading 1 (txt.i1), Heading 2 (txt.i2)
Printout Formats	See <a href="#">Section 3.12.1</a>
Set Type Terminator	Settings: CR, CR LF, <b>LF</b> (default), NO.TERM
Default Printout	Sets printout to default values

Table 3-30. Printout Configuration

### 3.12.1 Printout Formats

Available Values	Default Value
c.F. 01 (Simple printout)	331; 301; 301; 301; 300
c.F. 02 (Start dosage)	310; 301; 308; 301; 301; 301; 300
c.F. 03 (Restart dosage)	311; 301; 308; 301; 301; 301; 300
c.F. 04 (End dosage)	312; 301; 308; 331; 301; 301; 301; 300
c.F. 05 (Block belt)	313; 301; 308; 301; 301; 301; 300
c.F. 06 (Stop dosage)	316; 301; 308; 331; 301; 301; 301; 300
c.F. 07 (Pause dosage)	317; 301; 308; 301; 301; 301; 300
c.F. 08 (Partial total)	329; 301; 301; 301; 300
c.F. 09 (General total)	330; 301; 301; 301; 300
c.F. 10 (Handled article total)	416; 417; 424; 301; 301; 301; 300
c.F. 11 (Result of the calculator)	339; 032; 396; 301; 394; 032; 061; 301; 413; 395; 414; 300
c.F. 12 (Start-up printout)	300
c.F. 13 ... c.F. 30	300

Table 3-31. Printout Formats

All data blocks available in DiniTools or RiceLakeTools

Press F1: Enter a block or ASCII character

Press F2: Delete the line with the block or ASCII character

Press F3: Insert a print end (300)

Press Enter: Modifies the code in the current line

Press CLR: Exit

### 3.13 Database

Parameter	Description
Databases	Settings: Disable, <b>Enable</b> (default)
Article Field Enabling	Article fields: Description 2 – <b>Enable</b> (default) Description 3 – <b>Enable</b> (default) Description 4 – <b>Enable</b> (default) Description 5 – <b>Enable</b> (default) INI.VAL.PID (PID start value) – <b>Enable</b> (default) Flow rate target – <b>Enable</b> (default) Dosage target – <b>Enable</b> (default) Correction factor – <b>Enable</b> (default)
Set Access Password (Database)	Sets access password for article database; Zero value means password disabled
Initialize	Resets databases, articles and texts; ENTER = Yes, CLR = No

Table 3-32. Database

### 3.14 Input Text Configuration

Press F1: New input text, selected index or first free index

Press F2: Edit selected input text

Press F3: Delete selected input text

Available Values	Default Value
Description	
Text	
Threshold (max characters)	<b>32</b>
Mandatory input	<b>Disable</b>
Only void input	<b>Disable</b>

Table 3-33. Input Text Configuration

### 3.15 Set User Access Password

Sets the access password for all user functions. It is only possible to enable the password per function in DiniTools or RiceLakeTools.

### 3.16 Weight Zoom Enabling

Enable the zoom function of the flow display.

Available Values	Default Value
Disable	<b>Disable</b>
Enable	
Zoom delay	<b>5 sec</b>

Table 3-34. Weight Zoom Enabling

\*Delay to activate the zoom, only visible when zoom is enabled

### 3.17 Start-up Text

Set 2 lines of 16 character which will show during start-up.

### 3.18 Instrument Data Backup

Execute a backup of all settings. Confirm by pressing enter and enable the backup password (BAK.PWD) by entering a password.

### 3.19 External PC Keyboard Language

Available Values	Default Value
US.EN	US.EN
ITAL	
FRAN	
DEUT	

Table 3-35. External PC Keyboard Language

### 3.20 Instrument Sound Enabling

Available Values	Default Value
Disable	Disable
Enable	

Table 3-36. Instrument Sound Enabling

### 3.21 Reset Buffered RAM

Reset of the buffered RAM memory which contains database data, input texts, print formats and the headings.

### 3.22 Technical Default

Set all parameters to default, by pressing enter it's possible to choose:

Enter = Factory default

F1 = Load from backup

### 3.23 PID

PID algorithm is used to control the flow-rate. Analog output signal is managed to have the set target flow-rate.

Analog output is usually connected to the input of an inverter that will control the belt motor. Motor speed is proportional to the analog signal read by inverter.

PID value could also be directly read through Modbus/Fieldbus by a PLC that will use it to control the flow-rate.

In the PID algorithm are involved 3 main parameters:

- Kp: proportional gain
- Ki: integral gain
- Kd: derivative gain

On each PID algorithm iteration the following values are calculated:

- Error = (current value) - (target value)
- (Error sum) = (Error sum) + Error
- (Differential error) = Error - (Previous error)
- (Previous error) = Error

The PID algorithm output is:

$$\text{PID} = K_p * \text{Error} + K_i * (\text{Error sum}) + K_d * (\text{Differential error})$$

Other PID parameters:

- Action interval: time interval between 2 PID iterations

Analog output management:

On every PID iteration the analog output signal is set to:

$$\text{Analog output} = \text{PID value (\%)} * (\text{Analog output span}) / 100 + (\text{Analog output zero value})$$

If the PID value remains below minimum value (0%) or over maximum value (100%) for more than 5 iterations sum error is not updated. When the Error makes Sum error, in absolute value, decrease Sum error is updated again. This is to recover quickly from an empty belt condition lasted for long time.

## 3.24 Article Database

To modify or select an article from the database use the user function codes from the main screen. Enter the function code and press enter.

Function code 316: Article database management

Press F1: New article, selected index or first free index.

Press F2: Edit selected article.

Press F3: Delete selected article.

Press F4: Search article.

Press F5: Print article.

Press Enter: Select article.

Press Alt: Unselect article.

Function code 317: Select article in alphabetical order.

Press enter: Select the selected article.

## 4.0 Electrical Connections

The following sections provide graphic representations of the electrical connections for a WE503D Dynamic Integrator.

### 4.1 Mother Board

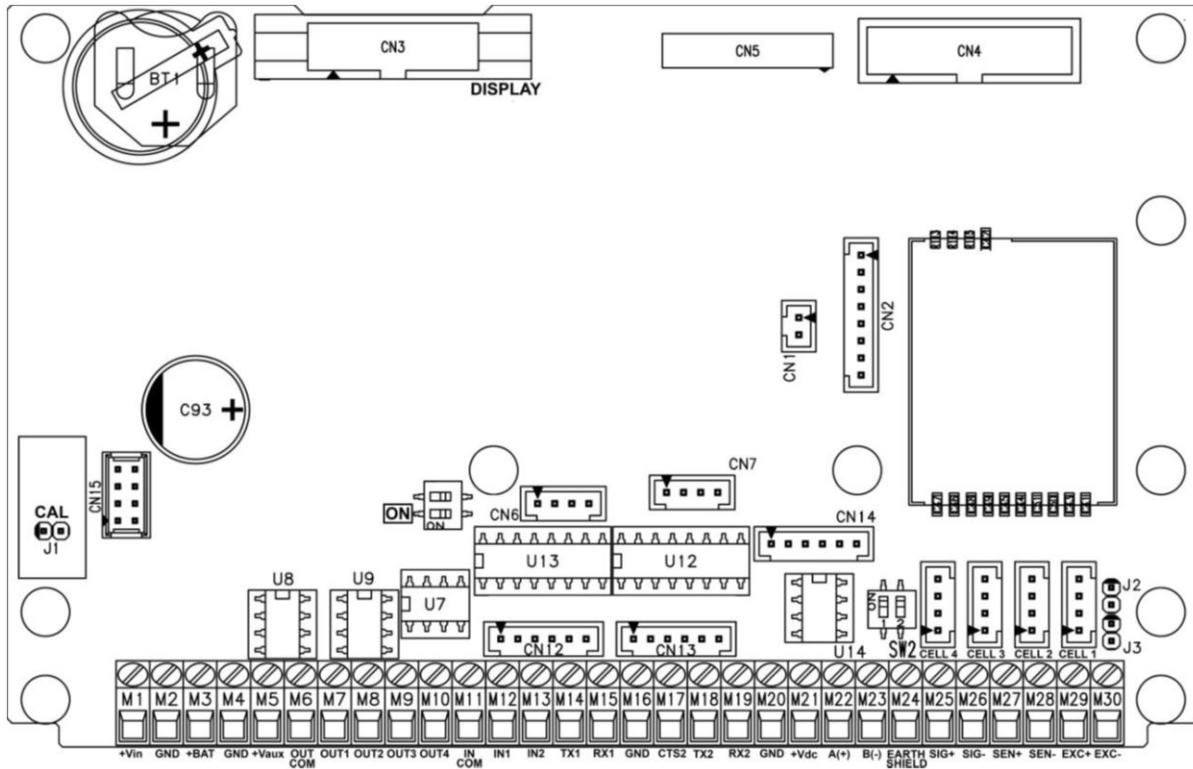

Figure 4-1. Mother Board

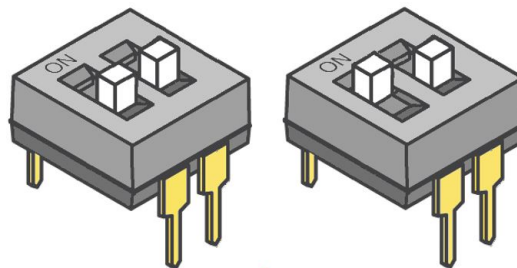

Figure 4-2. Switches



**WARNING:** There aren't any differences between the two switches pictured in [Figure 4-2](#). It doesn't matter which is "ON" and it is enough to activate only one.

**ON SW:** If closed, one can automatically turn on the instrument, as soon as the power voltage is supplied, one must also turn off the instrument by removing the mains voltage.

If open, one can turn the instrument on and off by just pressing the ON key.

**J2, J3 (SENSE):** If closed, Excitation + and Sense +, Excitation - and Sense - are bridged on the board.

**J1:** If opened it enables the access to the metrological parameters, when configuring.

### 4.1.1 Serial Ports

COM 1	COM 2	COM 3
Connector AMP CN12: Serial 232 Terminals 14-15-16: Serial 232	Connector AMP CN13: Serial 232 Terminals 16-17-18-19: Serial 232	Connector AMP CN14: Serial 232 Terminals 22-23: Serial 485 (U14)

Table 4-1. Serial Ports

### 4.1.2 Power Supply

6 VDC Battery Power Supply	+VDC Power Supply	V-AUX Auxiliary Power Supply	+VDC (OUT) Power Supply
3 +BAT (+6 VDC) 4 GND (0 VDC)	1 +VDC (+12 VDC, 8 ÷ 36 VDC with I/O expansion board connected) 2 GND (0 V)	4 GND (0 V) 5 +Vaux (5, 3-8 VDC 400 mA max)	20 GND (0 V) 21 +VDC (+12 VDC only if connected to the power supply)

Table 4-2. Power Supply

### 4.1.3 Load Cell Connection (Terminal Board Connection)

25	SIG+	SIGNAL+
26	SIG-	SIGNAL-
27	SENS+	SENSE+
28	SENS-	SENSE-
29	EXC+	EXCITATION+
30	EXC-	EXCITATION-

### 4.1.4 Inputs (Optoisolator Photocouplers)

Power Supply: 12 VDC ÷ 24 VDC max 20 mA

### 4.1.5 Photomosfet Outputs

Maximum Power: 48 VAC or 60 VDC, 150 mA max., 10 ohm max



**IMPORTANT:** The optoisolation of the inputs and outputs is obtained by powering the common of the outputs and/or of the inputs by using a voltage outside the instrument.

### 4.1.6 RS232 Serial Port (RJ11 Connector)

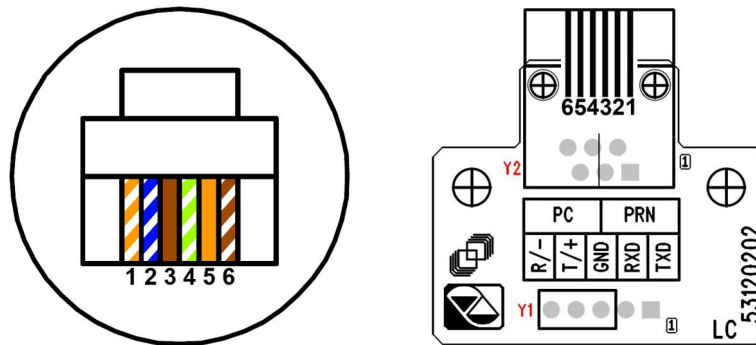

Figure 4-3. RJ11 Connector

### RJ11 Connections

Y2	RJ11	DB9	COLOR	MEANING
1	1		ORANGE WHITE	
2	2	3	BLUE WHITE	RX
3	3		BROWN	
4	4	5	GREEN WHITE	GND
5	5	2	ORANGE	TX
6	6		BROWN WHITE	

## 4.2 I/O Expansion Board

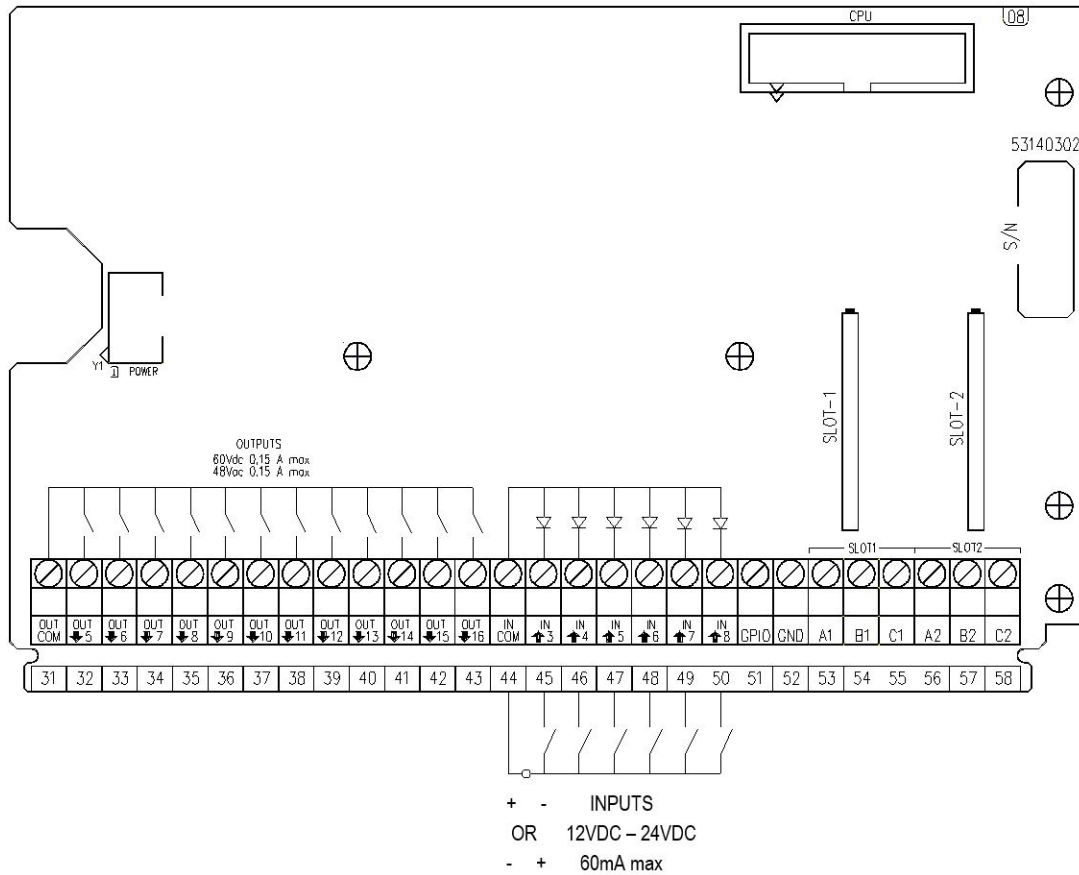

Figure 4-4. I/O Expansion Board

### 4.2.1 Analog Output

I/O1 (Slot 1)	I/O2 (Slot 2)
53 I+ (A1) + 20 mA	56 I+ (A2) + 20 mA
54 COM- (B1) 0 mA / V	57 COM- (B2) 0 mA / V
55 V+ (C1) + 10 V	58 V+ (C2) + 10 V

Table 4-3. Analog Output



**NOTE:** The maximum resistance applicable to the output current is 350 Ohm and the minimum resistance applicable to the output voltage is 10 Kohm.

### 4.2.2 Inputs (Optoisolator Photocouplers)

Power Supply: 12 VDC ÷ 24 VDC max 20 mA

### 4.2.3 Photomosfet Outputs

Maximum Power: 48 VAC or 60 VDC, 150 mA max., 10 ohm max



**IMPORTANT:** The optoisolation of the inputs and outputs is obtained by powering the common of the outputs and/or of the inputs by using a voltage outside the instrument.

### 4.3 Integrated Circuits Installation

It is necessary to follow this procedure to install Output, RS485 and Input integrated circuits.

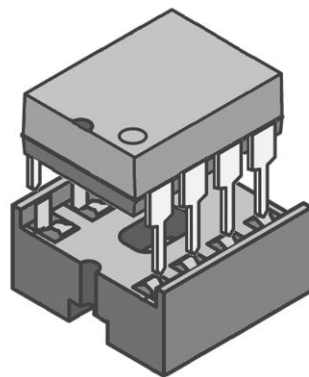
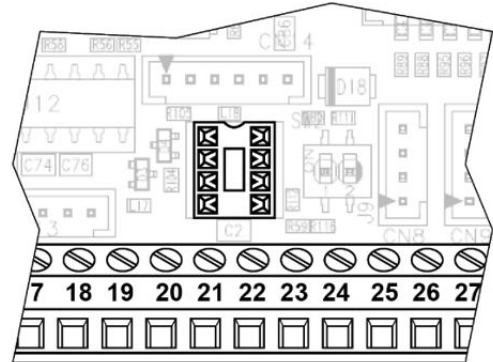
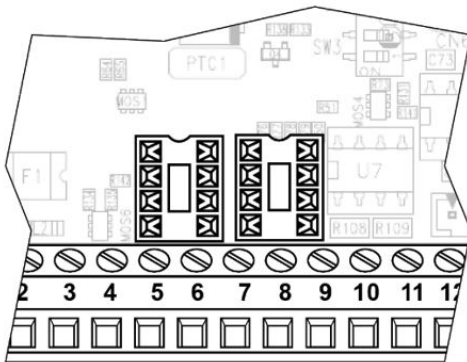
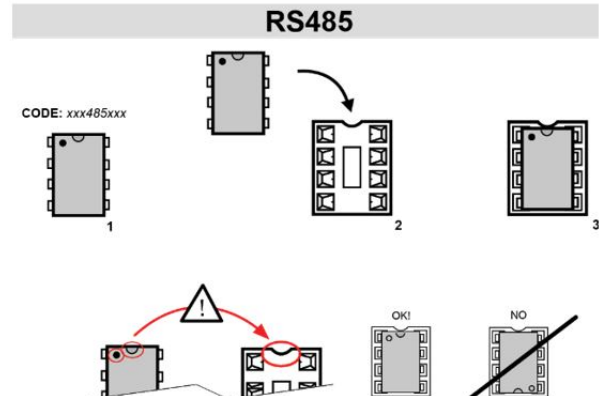
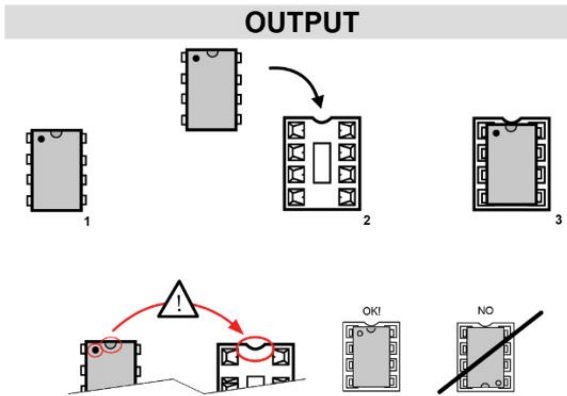

## Integrated Circuits Installation (Continued)

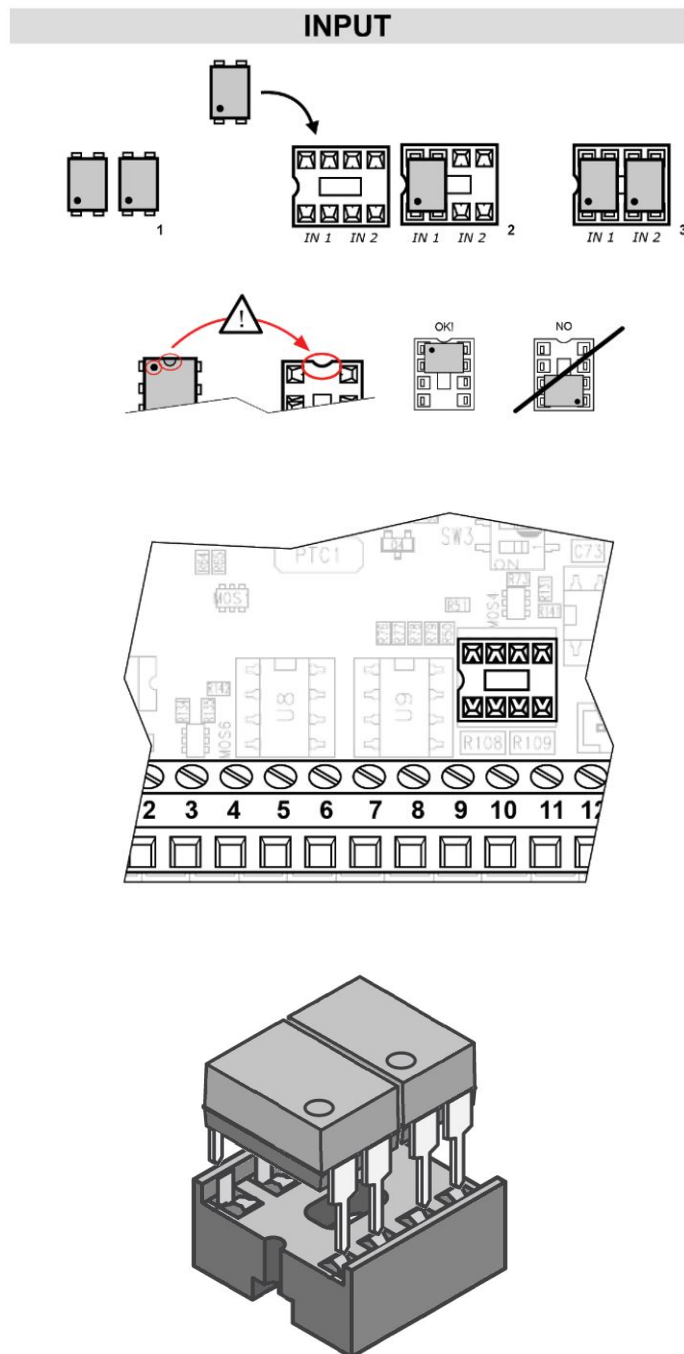

## 4.4 Display Board

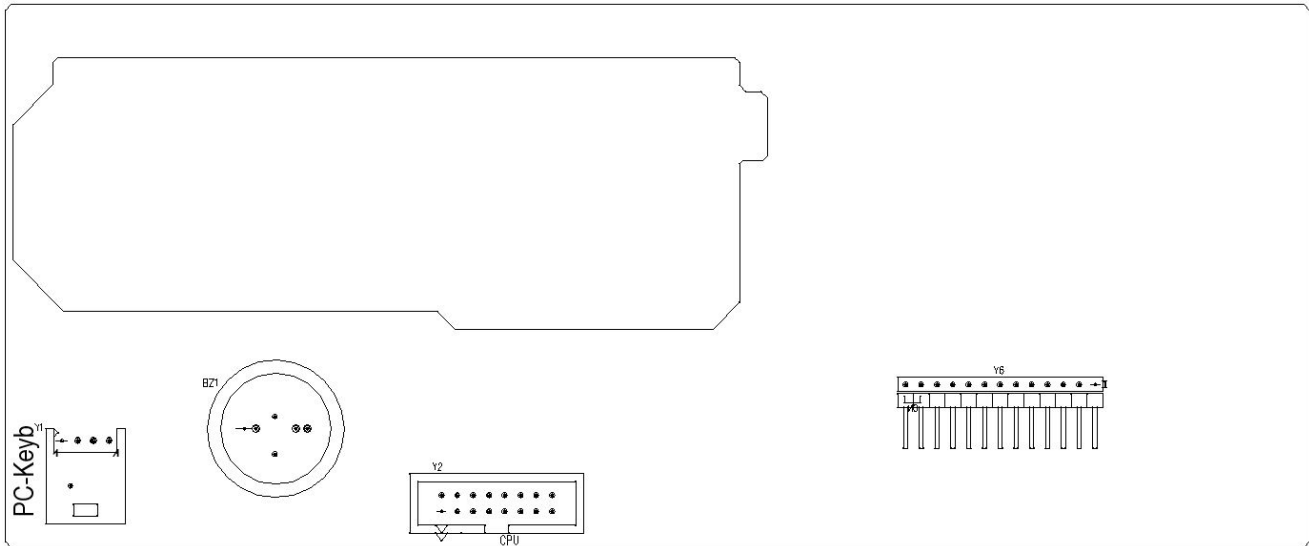

Figure 4-5. Display Board

### 4.4.1 PC-KEYB – PC Keyboard Connector

Keyboard emulation input, usable for the connection of the instrument to the PC keyboard or the badge/bar code reader.

PC-KEYB		PS/2
1	+5 V	4
2	GND	3
3	DATA	1
4	CLK	5

# 4.5 Connection Diagrams

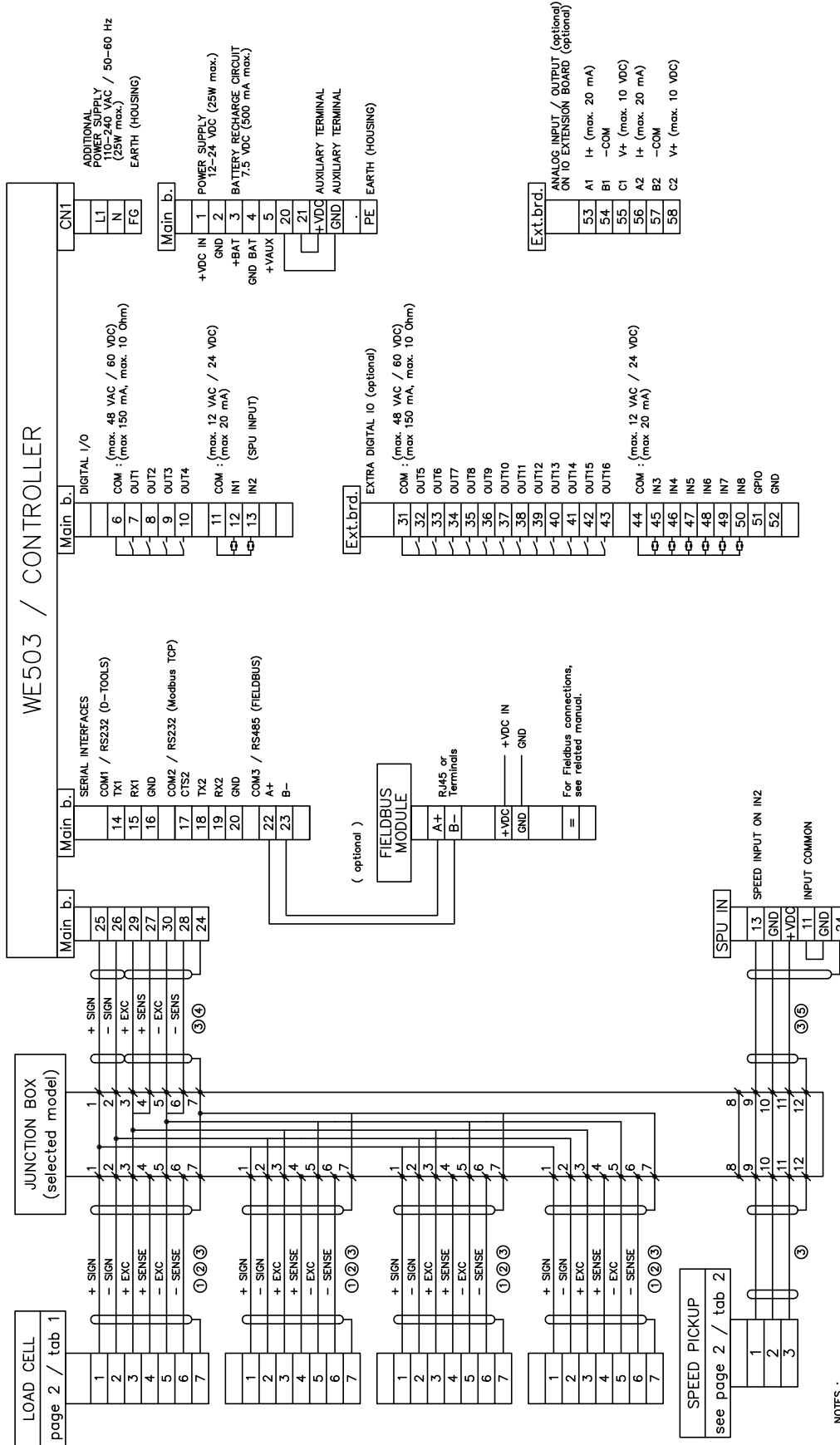

- NOTES :
- ① DO NOT ALTER LENGTH OF CABLE SUPPLIED WITH LOAD CELL
  - ② LOADCELLS CAN BE 4- OR 6-WIRES
  - ③ DO NOT RUN SIGNAL WIRES IN SAME CONDUIT AS POWER WIRING
  - ④ USE SHIELDED CABLE 6x0.75 to 6x1 mm2 (WITH SENSE)
  - ⑤ USE SHIELDED CABLE 4x0.75 to 4x1 mm2

TAB 1

WIRE NR.	LOADCELL MODEL	RLx4xx RL9x	RL19 RL30 RL35 RL42 RL46 RL65 RL74 RLx3xx H8H	B3G B8D BM8D H8C H9C L6D L6B L6E L6L CHP 9123	BM11 BM8H SHB ACB BM6A B6Q HPS HCB PCB 10-31H SENSOR	SSB BSP ALC CSP-M B6N	L6T L6N 652 642C	L6G L6W BM6G P PX	(J)BM CS CF CSI	H8CH	BM24R RLC	L6Q 1040 1140 1250 1510 640	T95 T61 VC3500 T93 BSM SSM	EXTENSION CABLE RICE LAKE	EXTENSION CABLE LYCY
1	+ SIGNAL	GREEN	RED	GREEN	WHITE	WHITE	GREEN	GREEN	GREEN	WHITE	BROWN	RED	GREEN	GREEN	PINK
2	- SIGNAL	WHITE	WHITE	WHITE	RED	RED	WHITE	WHITE	WHITE	GREEN	WHITE	WHITE	YELLOW	WHITE	WHITE
3	+ EXCITATION	RED	GREEN	RED	GREEN	GREEN	RED	RED	RED	RED	PINK	GREEN	RED	RED	GREEN
4	+ SENSE	YELLOW	BLUE*	x	YELLOW*	BLUE*	BLUE	BLUE	VIOLET*	x	x	BLUE	x	YELLOW	YELLOW
5	- EXCITATION	BLACK	BLACK	BLACK	BLACK	BLACK	BLACK	BLACK	BLACK	BLACK	GRAY	BLACK	BLUE	BLACK	GRAY
6	- SENSE	BLUE	YELLOW*	x	BLUE*	YELLOW*	BROWN	YELLOW	GRAY*	x	x	BROWN	x	BLUE	BROWN
7	SHIELD		CLEAR	ORANGE CLEAR	ORANGE CLEAR	ORANGE CLEAR	CLEAR	CLEAR	CLEAR	ORANGE CLEAR	CLEAR	CLEAR	CLEAR	MANTLE	MANTLE

\* = OPTIONAL TYPE

TAB 2

WIRE NR.	SPEEDPICKUP MODEL	5020 5026 7020	M12 Connector CABLE	2160N 2160EN	6012C 6012EN	012P E57 (pnp)	EXTENSION CABLE RICE LAKE	EXTENSION CABLE LYCY
1	+ SIGNAL A	GREEN	GREEN	1	15	BLACK 4	GREEN	GREEN
2	- COM	WHITE	WHITE	2	16	BLUE 3	WHITE	WHITE
3	+ POWER	BROWN	BROWN	3	17	BROWN 1	BROWN	BROWN
4	SHIELD	MANTLE	MANTLE	-	-	-	MANTLE	MANTLE

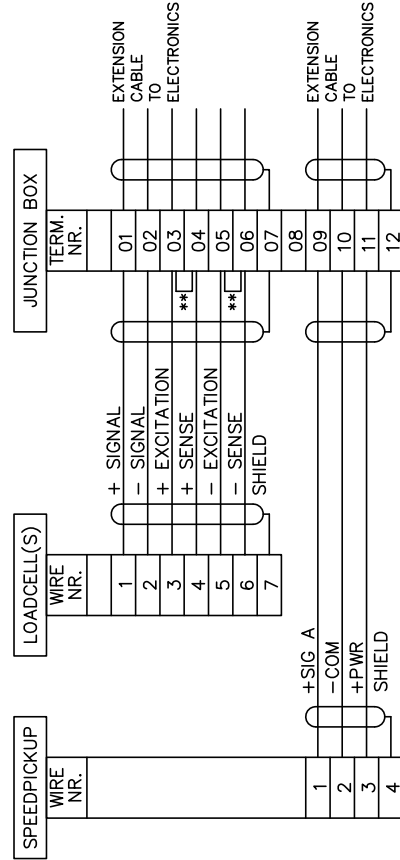

\*\* : MAKE JUMPERS ONLY IF THE LOADCELL HAS NO SENSE-WIRE

## 4.6 Dimension Drawings

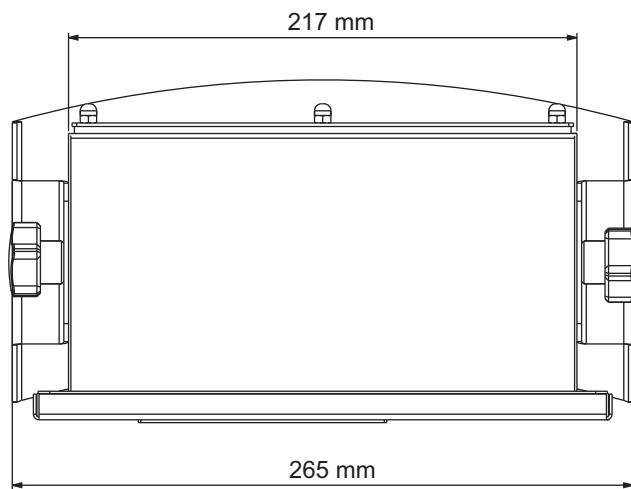
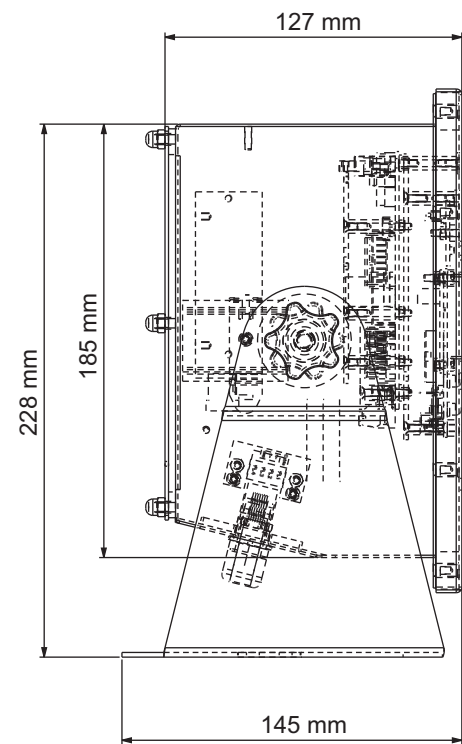
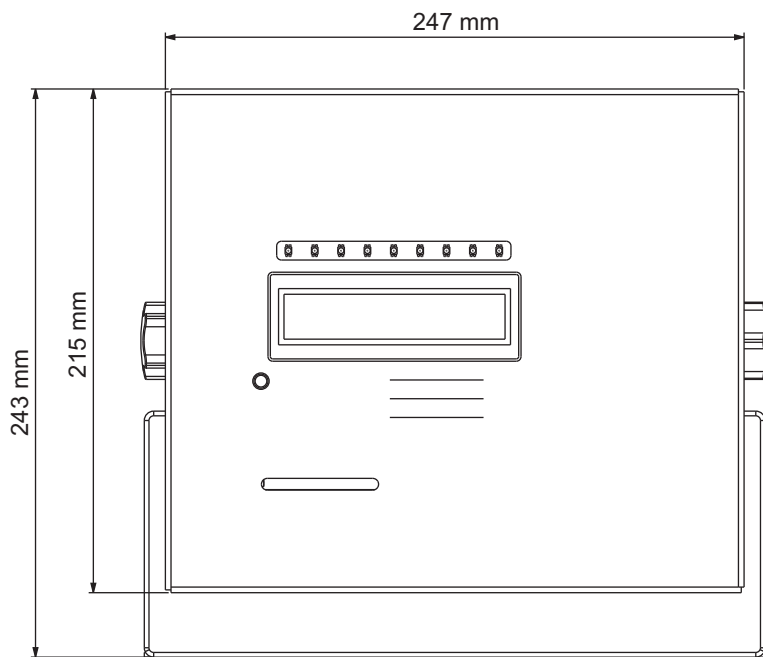

## 5.0 Setup Password

---

Password: 41042





© Rice Lake Weighing Systems Content subject to change without notice.

230 W. Coleman St. • Rice Lake, WI 54868 • USA USA: 800-472-6703 • International: +1-715-234-9171