

Dealer Software Guide

The screenshot displays the VIRTUlink Dealer Software interface. On the left is a dark sidebar with the VIRTUlink logo and navigation options: Home (selected), Assets, and a settings gear. The main content area has a red header with a menu icon and is divided into several sections:

- Home**: The main navigation header.
- Recent Alerts**: A list of alerts for Wednesday, Dec 06, 2023:
 - Junction Box Disconnected**: MMU Van MM1, 06 Dec 2023 15:36:35.
 - Cell Overload**: Rice Lake Weighing Systems (TJ) VIP, 06 Dec 2023 14:49:48.
 - Cell Overload**: Rice Lake Weighing Systems (TJ) VIP, 06 Dec 2023 14:49:28.
 - Gateway Disconnected**: (partially visible).
- Most Recent Service Notes**: A list of service notes:
 - Rice Lake Weighing Systems (TJ), YARD**: Gateway Disconnected, 25 Oct 2023 12:07:20. Note: "The gateway device is disconnected. Networking is down because the wireless bridge got fried. It got knocked down and filled with water. A replacement needs to be found. Down until it is replaced."
 - RLWS Tradeshow, TS1**: taken offline for shipment to tradeshow, TJDealer, 22 Feb 2023 11:03:40. Note: "Put in a shipping container of some kind."
 - RLWS WI Bldg 4 - Roughdeck**: Cellular Router fixed, 09 Feb 2023 16:31:12.
 - RLWS WI Bldg 4 - Roughdeck**: (partially visible).
- Assets under watch**: A card showing "Rice Lake Weighing Systems (TJ)/RLWS WI Bldg 12 - Roughdeck" with a green checkmark and contact info: "Contact: Terry Noon 9999999999".
- Emulation Mode Scales**: A card showing "No Emulation Mode Scales".

© Rice Lake Weighing Systems. All rights reserved.

Rice Lake Weighing Systems® and iQUBE²® are a registered trademarks of Rice Lake Weighing Systems.

VIRTUlink™ is a trademark of Rice Lake Weighing Systems.

All other brand or product names within this publication are trademarks or registered trademarks of their respective companies.

All information contained within this publication is, to the best of our knowledge, complete and accurate at the time of publication. Rice Lake Weighing Systems reserves the right to make changes to the technology, features, specifications and design of the equipment without notice.

The most current version of this publication, software, firmware and all other product updates can be found on our website:

www.ricelake.com

Revision History

This section tracks and describes manual revisions for awareness of major updates.

Revision	Date	Description
A	February 18, 2022	Initial manual release with product launch
B	January 16, 2023	Established revision history; Added Gateway LED information
C	February 13, 2024	Updated for VIRTUlink 2.0: <ul style="list-style-type: none"> • Updated Home, Assets, and Asset Details pages • Added iQube page, Accessories tab, Notification Settings

Table i. Revision Letter History



Technical training seminars are available through Rice Lake Weighing Systems. Course descriptions and dates can be viewed at www.ricelake.com/training or obtained by calling 715-234-9171 and asking for the training department.

Contents

1.0 Introduction	7
1.1 Access to VIRTUlink Pages and Functions	7
1.2 Services Performed via Customer Service	7
1.3 Connection Overview	8
2.0 Site Navigation and Page Elements	9
2.1 VIRTUlink User Account Creation	9
2.2 Logging In to VIRTUlink	9
2.2.1 Changing Password	9
2.3 VIRTUlink Menus	10
2.3.1 Hiding and Displaying Menus	10
2.3.2 Main Menu	11
2.3.3 Settings Menu	11
2.4 VIRTUlink Pages	12
2.4.1 Home Page	12
2.4.2 Assets Page	12
2.4.3 Assets Details Page	15
2.4.4 iQUBE Page	18
2.5 Mobile Navigation	19
2.5.1 Horizontal Orientation	19
2.5.2 Vertical Orientation	20
2.6 Account Information	21
2.6.1 Viewing Profile Settings	21
2.6.2 Editing Profile Settings	21
2.7 Logout of VIRTUlink	22
3.0 Configuration	23
3.1 Notification Settings	23
3.1.1 Accessing Notification Settings	23
3.1.2 Configuring Notifications Setting	25
3.1.3 Enable/Disable Temporary Notification Settings	26
3.2 Watch List Configuration	27
3.3 Edit VIRTUlink Scale Parameters	29
3.4 Edit VIRTUlink iQUBE Parameters	30
4.0 Asset Details Page Features	32
4.1 Load Cell Details	32
4.1.1 Accessing Cell Details	32
4.1.2 About Load Cell Details Window	33
4.2 IP Camera	34
4.3 Alert History	35
4.3.1 Viewing Recent Alerts on the Home Page	35
4.3.2 Viewing Alert History from Asset Details Page	36
4.4 Service Notes	37
4.4.1 Adding Service Notes in the Service Notes Tab	37
4.4.2 Adding a Service Note in Alert History	38
4.5 Asset Console	39
4.6 Accessories	40



Rice Lake continually offers web-based video training on a growing selection of product-related topics at no cost. Visit www.ricelake.com/webinars

5.0 Emulation Mode 41
 5.1 Emulation Mode Examples 41

6.0 Troubleshooting 44
 6.1 Error Messages 44
 6.2 Error Email Messages 44
 6.3 Gateway Status LEDs 45



Technical training seminars are available through Rice Lake Weighing Systems. Course descriptions and dates can be viewed at www.ricelake.com/training or obtained by calling 715-234-9171 and asking for the training department.



Rice Lake continually offers web-based video training on a growing selection of product-related topics at no cost. Visit www.ricelake.com/webinars

1.0 Introduction

VIRTUlink™ is an Internet cloud service that operates in conjunction with the iQUBE²® junction box and an Internet gateway. VIRTUlink requires a modern computer or mobile device with a modern web browser. The service provides a website that operates similarly to many common websites and requires basic web browsing knowledge (logging in, selecting objects, opening menus, selecting options from menus and viewing data on pages).

VIRTUlink allows users to monitor scale health data received from the iQUBE² junction box and perform a variety of functions. The data transmitted to VIRTUlink includes:

- Current Weight
- Alert/Diagnostic Messages
- Raw Load Cell A/D Counts (Per Load Cell)
- Raw A/D Voltage (Per Load Cell)
- Scale/Load Cell Status
- Percentage of Load (Per Load Cell)

VIRTUlink also provides the following functionality:

- Viewing Alert History
- Emulation Mode (when enabled)
- Entering/Viewing Service Notes
- Terminal Program Access (EDP Command Console)
- Viewing IP Camera (for Systems Equipped with Optional Hardware)

1.1 Access to VIRTUlink Pages and Functions

Functionality in VIRTUlink varies depending on if the account is for an end-user or a dealer. In most cases dealer accounts have additional functions to facilitate operation and management. [Table 1-1](#) lists differences in access to VIRTUlink access and functions.

Access to VIRTUlink Pages			Access to VIRTUlink Functions		
Page	End-user	Dealer	Function	End-user	Dealer
Assets	X	X	Accessories	X	X
Asset Details	X	X	Account Settings	X	X
Home Page		X	Alert History	X	X
iQUBE page	X	X	Cell Details	X	X
			Console		X
			Edit Scale		X
			Edit iQUBE		X
			IP Camera	X	X
			Service Notes		X
			Watch List		X

Table 1-1. Access to VIRTUlink Pages and Functions

1.2 Services Performed via Customer Service

Some functions can only be performed by Rice Lake Weighing Systems customer service. A request to customer service must be submitted to perform the following tasks:

- Creating VIRTUlink User Accounts
- Editing Customer Account Information
- Editing Account Settings
- Changing Passwords

1.3 Connection Overview

A minimum of the following components are required to connect hardware used by VIRTUlink:

- Network Device and Cabling
- VIRTUlink Gateway (and power supply)
- iQUBE² with Ethernet TCP/IP option card
- Indicator/Scale (compatible with iQUBE²)

The VIRTUlink gateway connects to same network as the iQUBE² and receives/transmits device data to the VIRTUlink website. The iQUBE² responds to data requests from the gateway and provides data about the devices connected to it.



NOTE: iQUBE² must be connected to a local network that can be accessed by the IoT Gateway.



CAUTION: Do not provide iQUBE² access to the Internet or allow it to be accessible from the Internet.

Hardware configurations in VIRTUlink are categorized as sites. Sites are locations far enough away from each other that cannot share a Gateway.



NOTE: A site can have more than one Gateway.

Each configuration varies as requirements determine the quantity of iQUBE²s, VIRTUlink Gateways, and Indicator/scales. One VIRTUlink gateway can connect up to four iQUBE²s, and one iQUBE² can connect up to four scales for a maximum of 16 load cells.

Figure 1-1 displays an example of three sites with varying configurations.

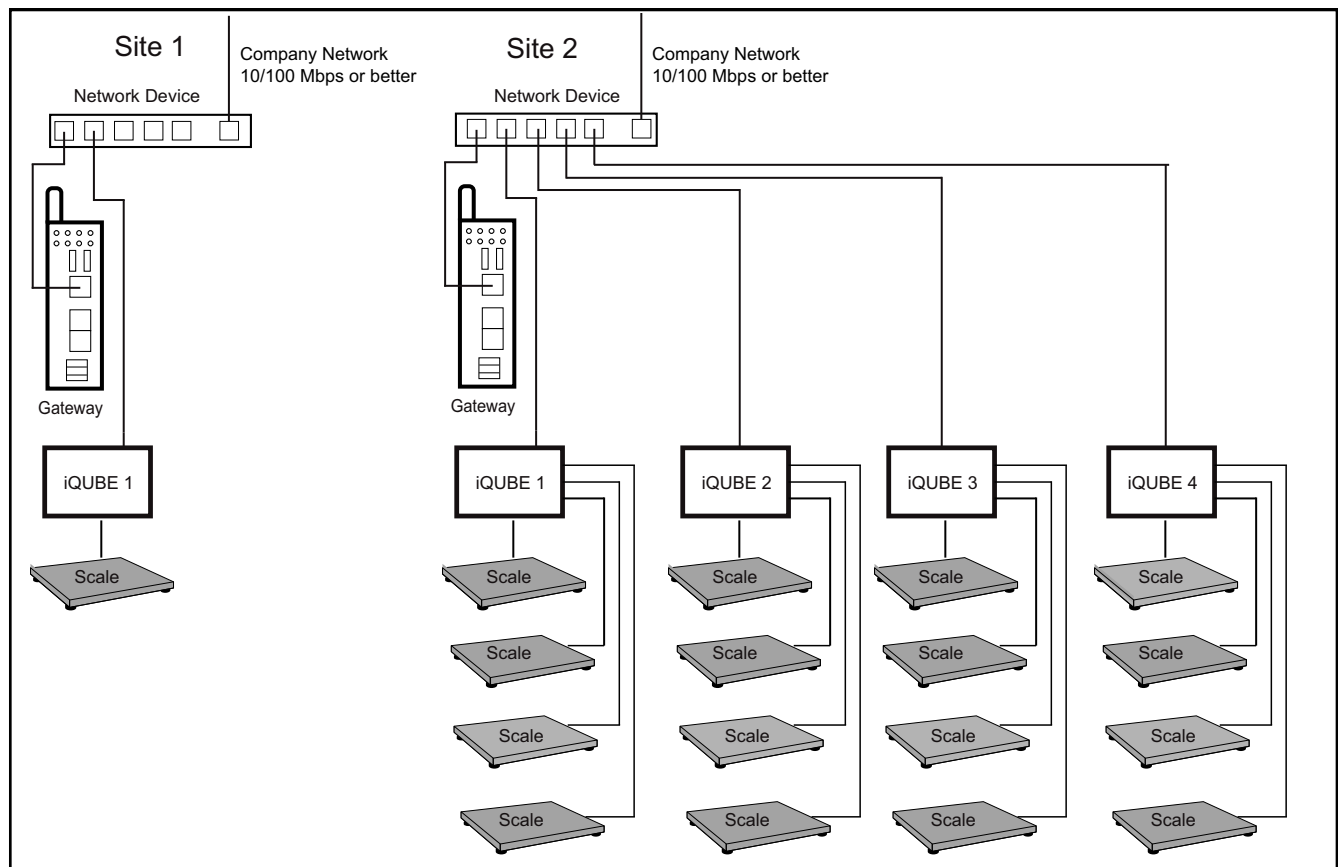

Figure 1-1. Network Overview Diagram

2.3 VIRTUlink Menus

2.3.1 Hiding and Displaying Menus

It is possible to hide and display the Main menu (left column in the portal).

1. While the Main menu is open, select the Menu button to hide it.

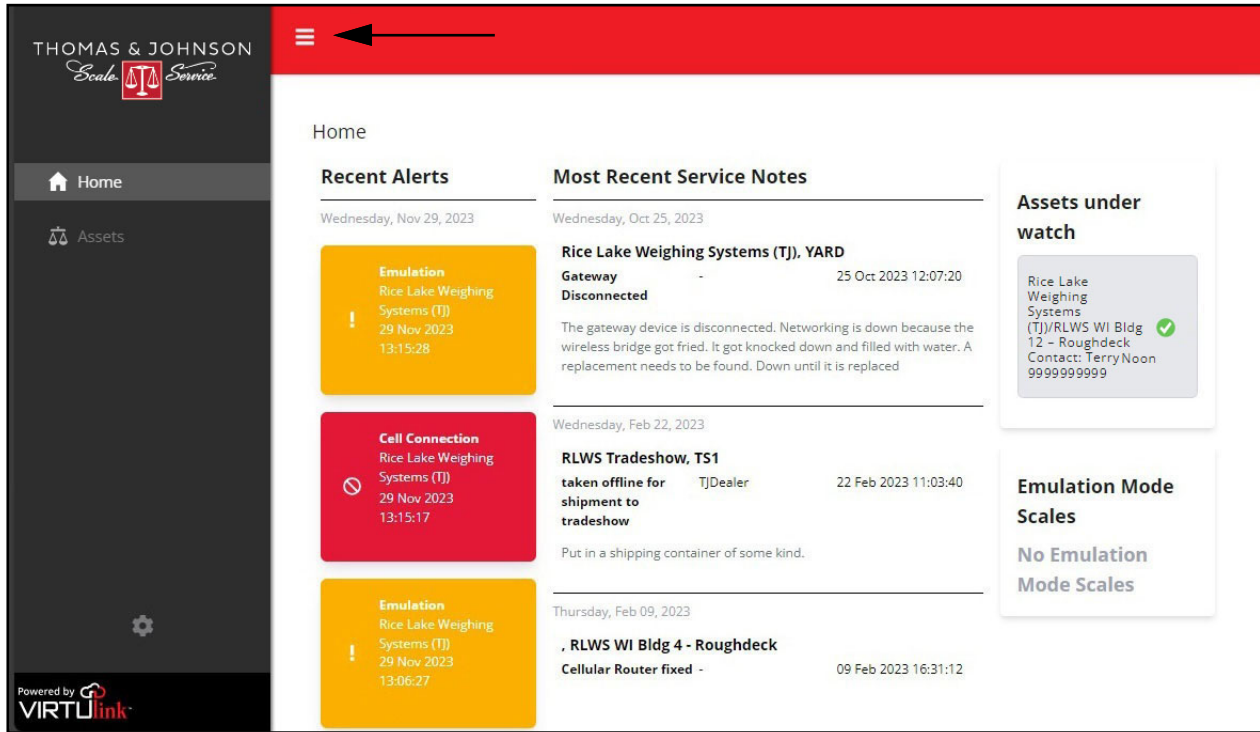

Figure 2-2. Home Page with Menu Button Identified

2. The Main menu hides.

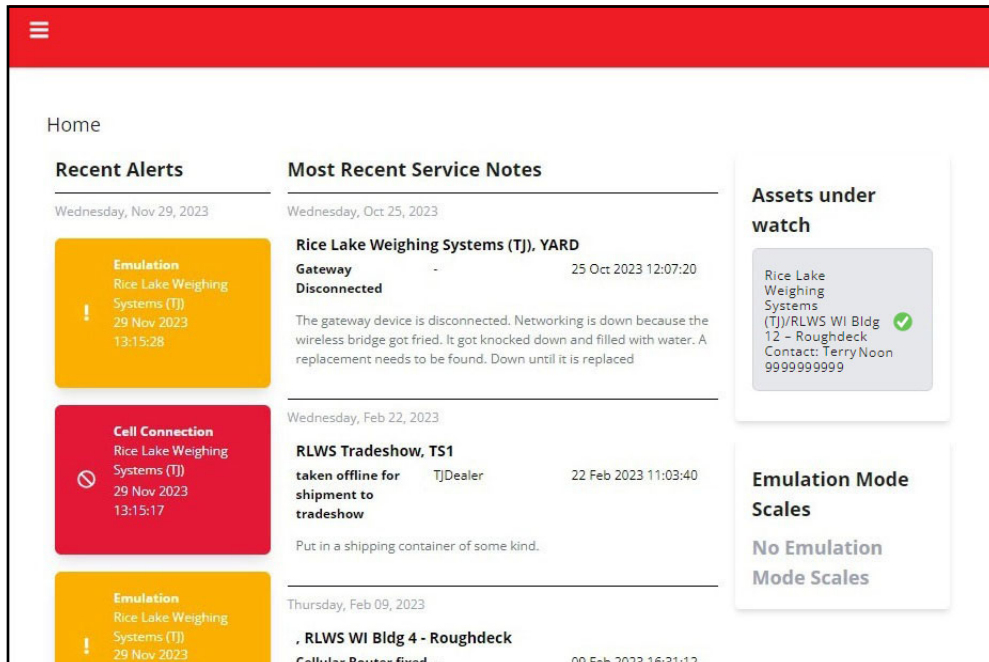



Figure 2-3. Home Page with Menu Collapsed

3. Select  (menu button) again to display the Main menu.

2.3.2 Main Menu

The Main menu is located along the left edge of VIRTUlink. If it is not currently available, verify if the Main menu is hidden (see [Section 2.3.1 on page 10](#)).

The Main menu contains two parameters that provides access to different VIRTUlink pages.

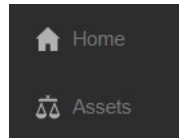

Figure 2-4. Main Menu

The Main menu has two options, described in [Table 2-1](#):

Options	Description
Home	Opens the Home page. This function is only available to dealers. For more information, see Section 2.4.1 on page 12 .
Assets	Opens the Assets page. For more information, see Section 2.4.2.2 on page 14 .

Table 2-1. Main Menu Options

2.3.3 Settings Menu

The Settings menu is located along the left edge of VIRTUlink beneath the Main menu. If the Settings menu is not currently available, verify if the menu is hidden (see [Section 2.3.1 on page 10](#)). Select the Settings menu icon to view its options.

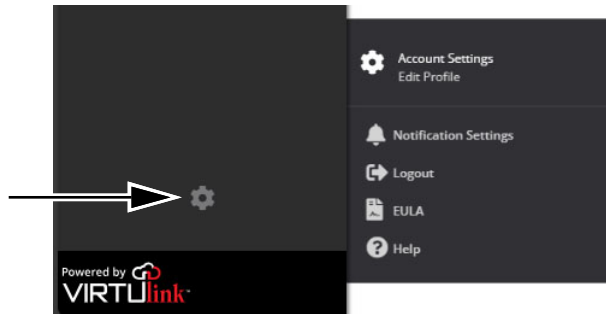

Figure 2-5. Settings Menu Expanded

[Table 2-2](#) describes the options in the Settings menu:

Option	Description
Edit Profile	Opens the Account Settings page for viewing. For more information, see Section 2.6 on page 21 . To edit profile settings, contact VIRTUlinkSupport@RiceLake.com
Notifications Settings	Opens Notification Settings page and allows scale notifications to be configured for each scale. For more information, see Section 3.1 on page 23 .
Logout	Logs out of VIRTUlink
EULA	Opens the End User License Agreement (EULA)
Help	Opens the VIRTUlink Help pages

Table 2-2. Settings Menu Options

2.4 VIRTUlink Pages

This section discusses VIRTUlink operational pages:

- Home page (see [Section 2.4.1 on page 12](#))
- Assets page (see [Section 2.4.2 on page 12](#))
- Assets Details page (see [Section 2.4.3 on page 15](#))
- Assets iQUBE page (see [Section 2.4.4 on page 18](#))

2.4.1 Home Page

The Home page provides information regarding alerts, service notes, watched assets and load cells in emulation mode.



NOTE: The Home page is only available to dealers.



NOTE: The Home page varies in appearance. The following is an example of how a Home page may appear.

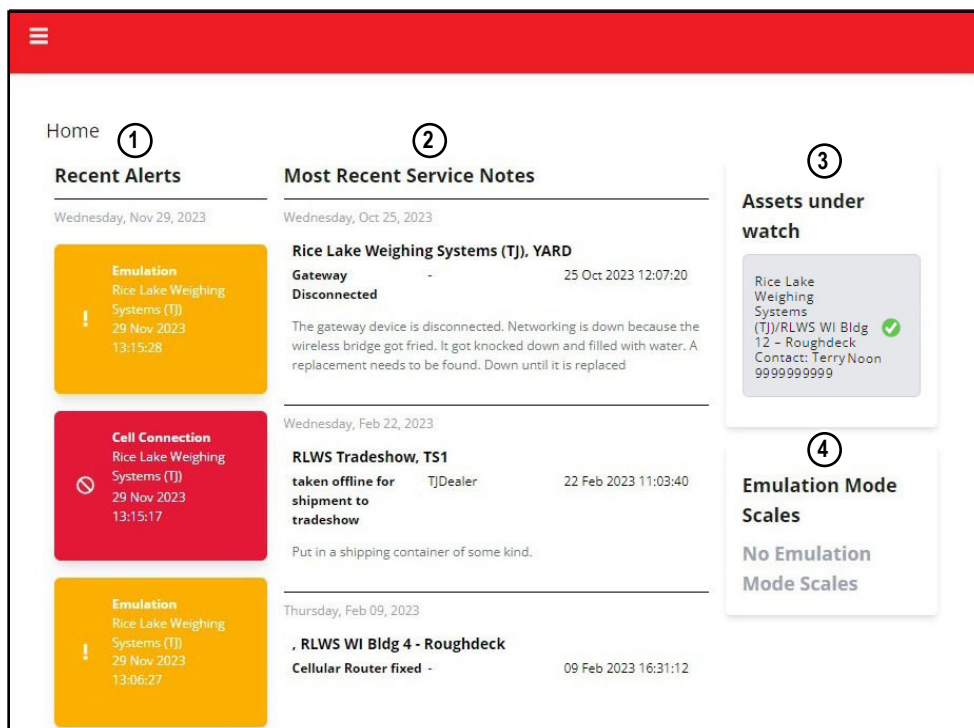

Figure 2-6. Home Page Elements

Elements identified in [Figure 2-6](#) are described in [Table 2-3](#):

Number	Feature	Description
1	Recent Alerts	Displays alerts received from assets in order of most recent. For more information, see Section 4.3 on page 35
2	Most Recent Service Notes	Lists service notes added to an asset in order of most recent. For more information, see Section 4.4 on page 37
3	Assets Under Watch	Displays a user defined list of assets. For more information, see Section 3.2 on page 27
4	Emulation Mode Load Cells	Displays load cells in emulation mode. For more information, see Section 5.0

Table 2-3. Home Page Elements Description

2.4.2 Assets Page

This section discusses two facets of the Assets page:

- Access Assets page (Section 2.4.2.1 on page 13)
- Assets page elements (Section 2.4.2.2 on page 14)

2.4.2.1 Access Assets Page

The features in this section are accessed from the Asset details page. Perform the following to access the Asset Details page.

1. Select **Assets** from the Main menu.

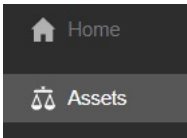

Figure 2-7. Main Menu Assets Option

2. The Assets Page displays.

Asset	Status	Dealership	Customer	Location	iQube	Gateway
Gunderson VIP	Clear		Rice Lake Weighing Systems (TJ)	Lester B Gunderson VIP room	IQVIP	VIP
Roughdeck	Clear		Rice Lake Weighing Systems (TJ)	Obeya 1	Pres	DD2
RLWS Tradeshow	Disconnected		RLWS Tradeshow	Obeya 2	IQT1	TS1
RLWS Van Demo	Disconnected		MMU	Obeya 2	IQM1	MM1
RLWS WI Bldg 12 - Roughdeck	Clear		Rice Lake Weighing Systems (TJ)	RLWS Building 12 NW corner	IQB12	DD1
RLWS WI Yard - TruckScale	Clear		Rice Lake Weighing Systems (TJ)	RLWS Steel Yard	KNK1	YARD
RLWS WI Yard - TruckScale 2	Clear		Rice Lake Weighing Systems (TJ)	RLWS Steel Yard	IQTC	TC1
Platter	Clear		Rice Lake Weighing Systems (TJ)	Platter in Obeya 1	Platter	DD2
Platter2	Clear		Rice Lake Weighing Systems (TJ)	Platter in Obeya 2	Ton	DD2
Trainer	Clear		Rice Lake Weighing Systems (TJ)	Obeya 1	IQTT	DD2

Figure 2-8. Assets Page

2.4.2.2 Assets Page Elements

The Assets page displays information relevant to assets. Information displayed includes the asset's status, dealership, customer, location, iQUBE and gateway.



NOTE: The Assets page varies in appearance. The following is an example of how an Assets page may appear.

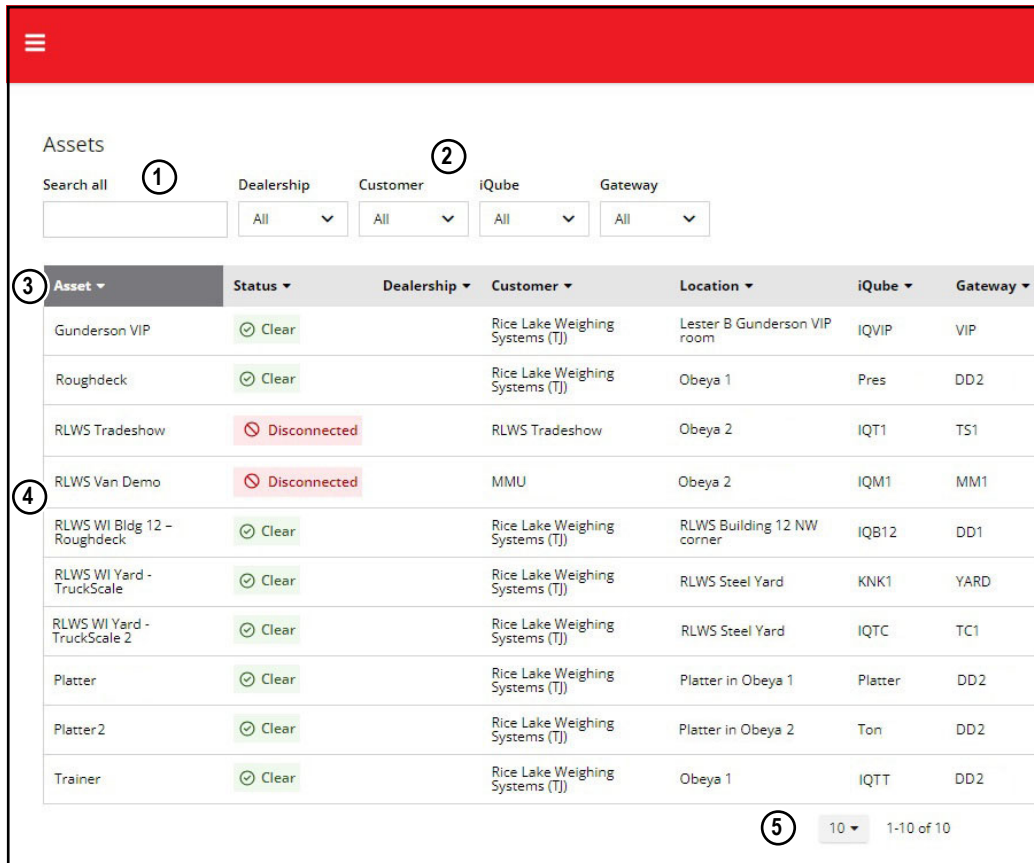

Figure 2-9. Assets Page Elements

Elements identified in Figure 2-9 are described in the Table 2-4:

Number	Feature	Description
1	Search All Text Field	Searches customer information for input keywords
2	Table Display Filters	Configures filters that determine what information displays on the Assets page
3	Ascending/Descending View Buttons	Sorts the column data in ascending or descending order
4	Asset Rows	Select the desired asset to view detailed information about it. For more information, see Section 2.4.3.2 on page 16
5	Row Quantity	Configures the quantity of rows displayed as either 10, 50 or 100.

Table 2-4. Assets Page Elements Description

2.4.3 Assets Details Page

This sections discusses two facets of the Asset Details page:

- Access Asset Details page (Section 2.4.3.1 on page 15)
- Asset Details page Elements (Section 2.4.3.2 on page 16)

2.4.3.1 Access Assets Details Page

1. Access an Assets page (see Section 2.4.2.1 on page 13).
2. Select the desired asset.

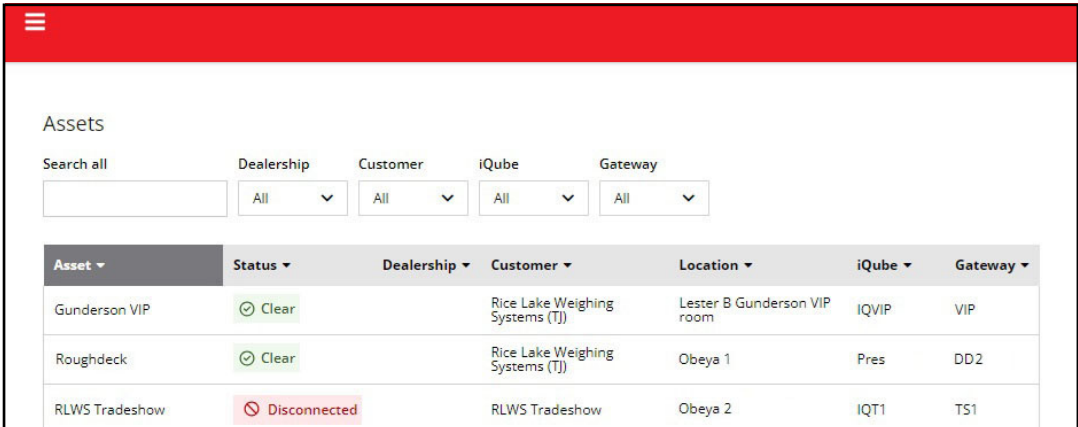
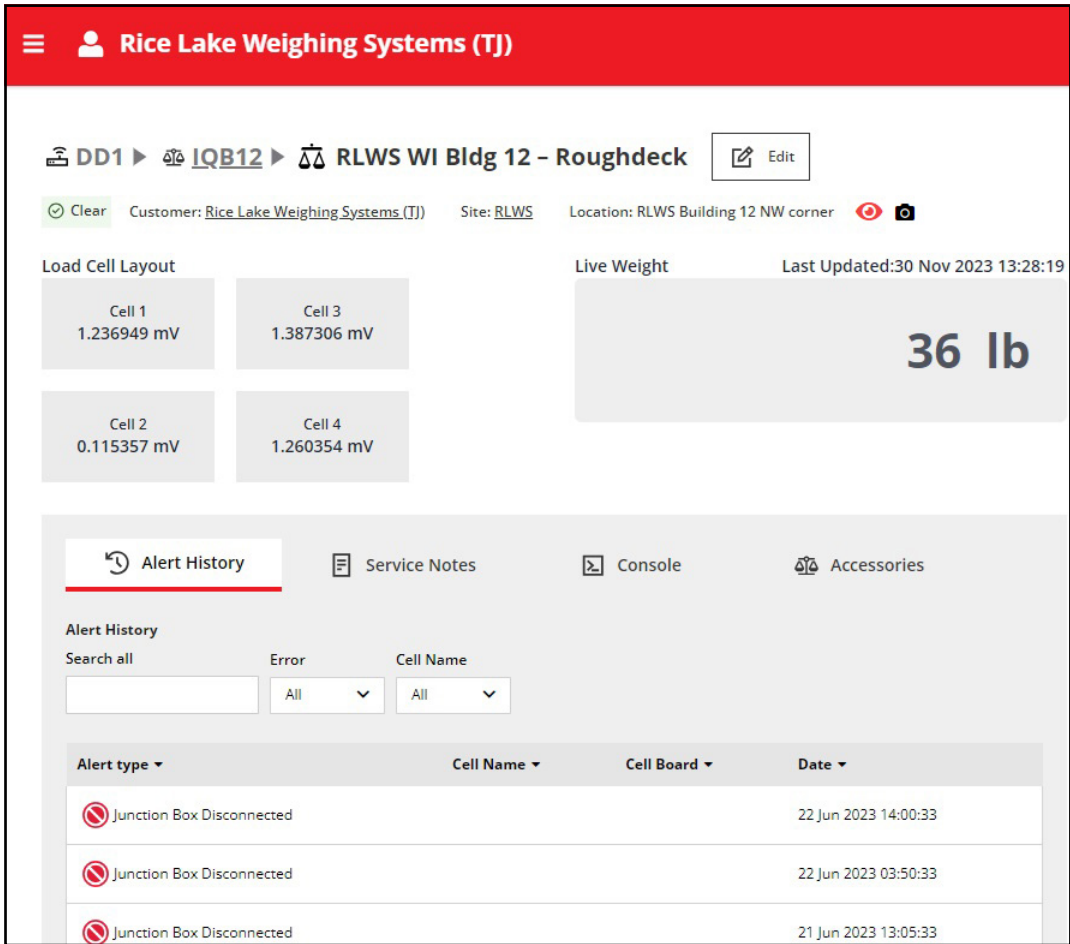

Figure 2-10. Assets Page

3. The Asset Details page displays.



Asset Details Page

2.4.3.2 Asset Details Page Elements

The Assets page displays additional details about the selected asset.



NOTE: The Asset Details page varies in appearance. The following is an example of how an Asset Details page may appear.

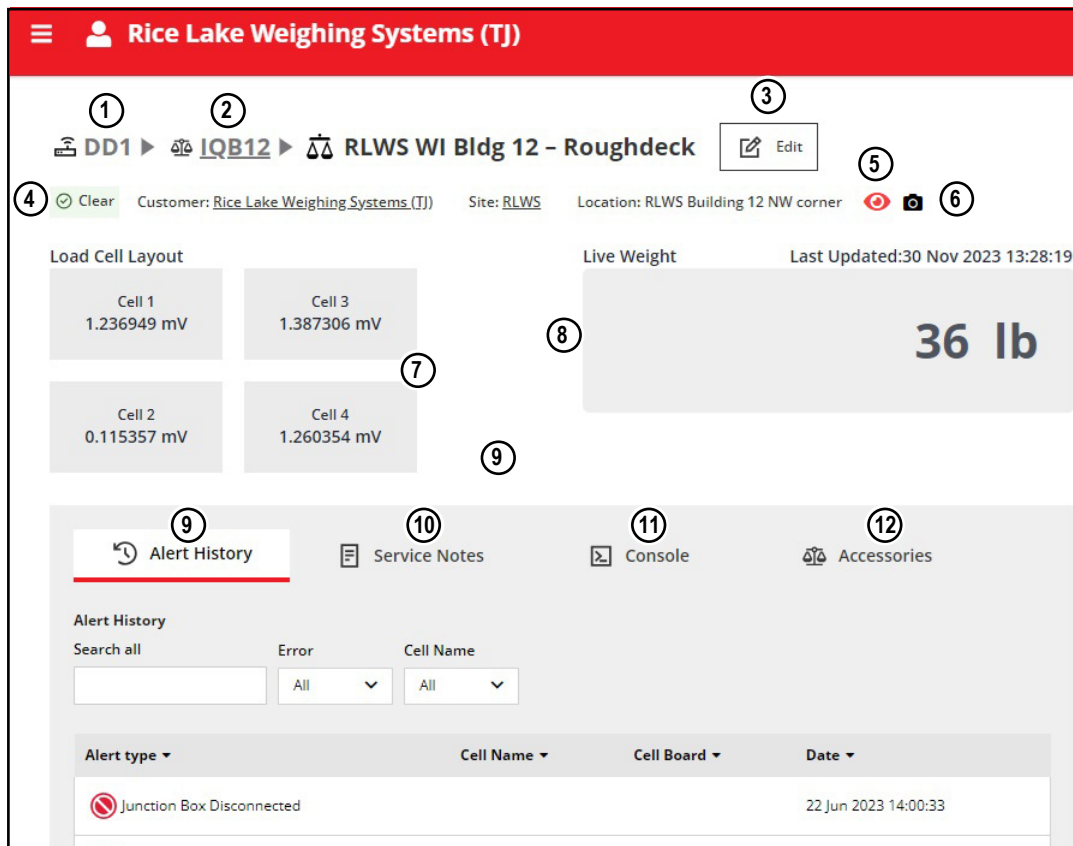

Figure 2-11. Asset Details Page Elements

Elements identified in [Figure 2-11](#) are described in [Table 2-5](#):

Number	Feature	Description
1	Gateway name	Displays the name of the Gateway.
2	iQUBE2	Displays the name of the iQUBE ² .
3	Edit Asset Button	Provides asset editing functionality. For more information see, Section 3.3 on page 29
4	Asset status	Displays asset status information. Provides the following status information: Clear, Disconnected, Emulation mode, Overload, Underload, Zero Reference Error, Cell Connection Error, Unbalanced Load Error, or Cell Drift.
5	Watch List Status	Displays if an asset is in the watch list, where: <ul style="list-style-type: none"> = In watch list = Off watch list For more information see, Section 3.2 on page 27
6	IP Camera	Opens the IP Camera viewer. This button is only available if an IP camera is configured. For More information, see Section 4.1 on page 32
7	Load Cell status	Displays load cell number and millivolt (mV) status. Select the load cell to display additional details about the load cell. For more information, see Section 4.1 on page 32
8	Scale Weight	Displays current weight on scale

Table 2-5. Asset Details Page Elements Descriptions

Number	Feature	Description
9	Alert History Tab	Displays historical alert messages, including: <ul style="list-style-type: none"> • Cell Connection (DIA.CELLCONNECT) • Cell Emulation • Cell Overload (DIA.OVERLOAD) • Cell Underload (DIA.UNDERLOAD) • Cell Drift (DIA.DRIFT) • Junction Box Disconnected • Gateway Disconnected • Peak Noise (DIA.NOISE) • Unbalanced Load Error (DIA.UNBAL) • Secondary Communication (DIA.MSCONNECT) • Zero Reference Error (DIA.ZREF) For more information, see Section 4.3 on page 35
10	Service Notes Tab	Displays historical notes typically created by service personnel. For more information, see Section 4.4 on page 37
11	Console Tab	Provides the ability to input electronic data processing (EDP) commands. For more information, see Section 4.5 on page 39
12	Accessories Tab	Provides a list of configured accessories (for example, IP camera). For more information, see Section 4.6 on page 40 .

Table 2-5. Asset Details Page Elements Descriptions (Continued)

2.4.4 iQUBE Page

Once the iQUBE is selected from the Asset Details page, VIRTUlink advances to the iQUBE Details page which displays additional details about the selected iQUBE.



NOTE: The iQUBE page varies in appearance. The following is an example of how an Asset Details page may appear.

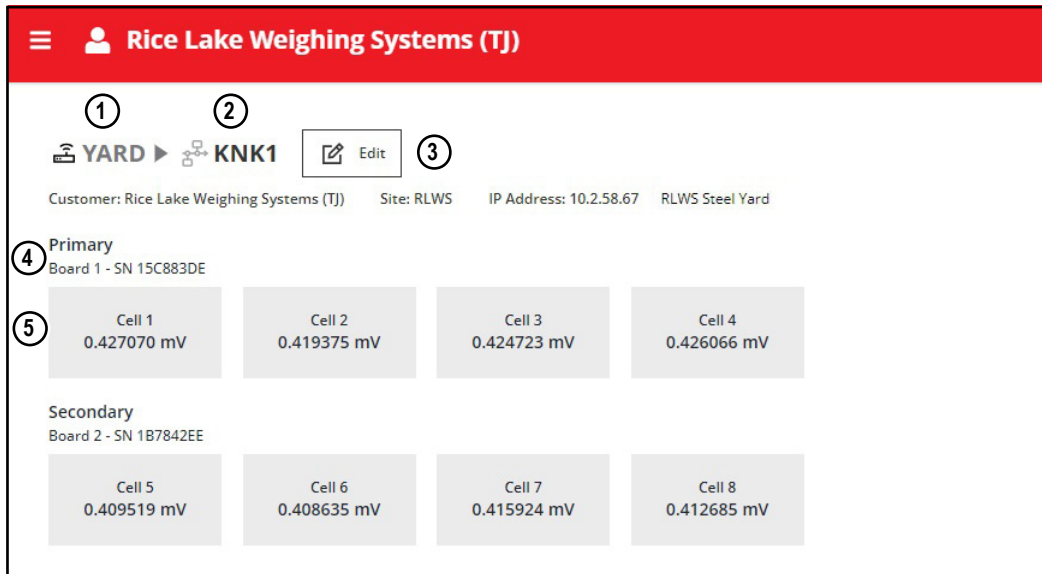

Figure 2-12. iQUBE² Details Page Elements

Elements identified in Figure 2-12 are described in Table 2-6:

Number	Feature	Description
1	Gateway Name	Displays name of the gateway the iQUBE is connected to.
2	iQUBE Name	Displays the name of the iQUBE
3	Edit iQUBE Button	Provides iQUBE editing functionality. For more information see, Section 3.3 on page 29 .
4	Board Information	Displays the type of board (primary or secondary) with serial number and associated load cells. NOTE: There can be up to 4 boards in an iQUBE; one primary and up to three secondary boards. For more information about primary and secondary boards, see iQUBE² Installation Manual (PN 106113).
5	Load Cell Status	Displays load cell number and millivolt status. Select the load cell to display additional details about the load cell. For more information, see Section 4.1 on page 32 .

Table 2-6. iQUBE² Details Page Elements Descriptions

2.5 Mobile Navigation

In addition to computers, VIRTUlink may be accessed from mobile devices. The mobile device experience is similar to a computer experience, however, there are appearance and usage differences. The orientation of the mobile device's screen (vertical or horizontal) determines the layout of VIRTUlink. Pages may be truncated on the screen and require horizontal or vertical scrolling to view the entirety of the page.

 **NOTE: VIRTUlink is compatible with most current mobile devices. If you experience issues with VIRTUlink on a mobile device, try using a different orientation, desktop mode, or web browser.**

 **NOTE: Images included in this section are for reference. VIRTUlink appearance may vary depending on mobile device, screen resolution, web browser and operation system.**

2.5.1 Horizontal Orientation

Horizontal orientation is most similar to a computer layout. The one noticeable difference is that the Home page displays one column instead of several.  (Menu button) opens and closes the menu from the left side.

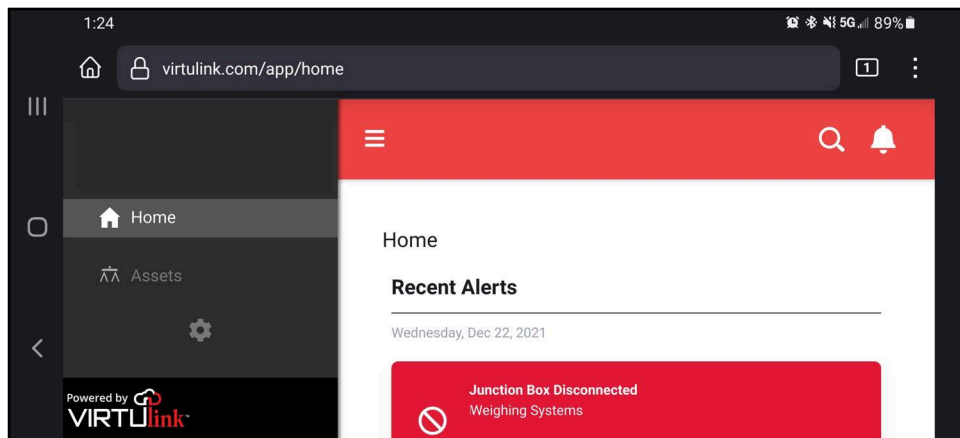



Figure 2-13. Horizontal Navigation Example

2.5.2 Vertical Orientation

Vertical orientation displays one column instead of several in the Home page.  (Menu button) opens and closes the Main menu from the left side that spans across the screen. In this orientation, the Main menu and Settings menu are merged into a single menu.

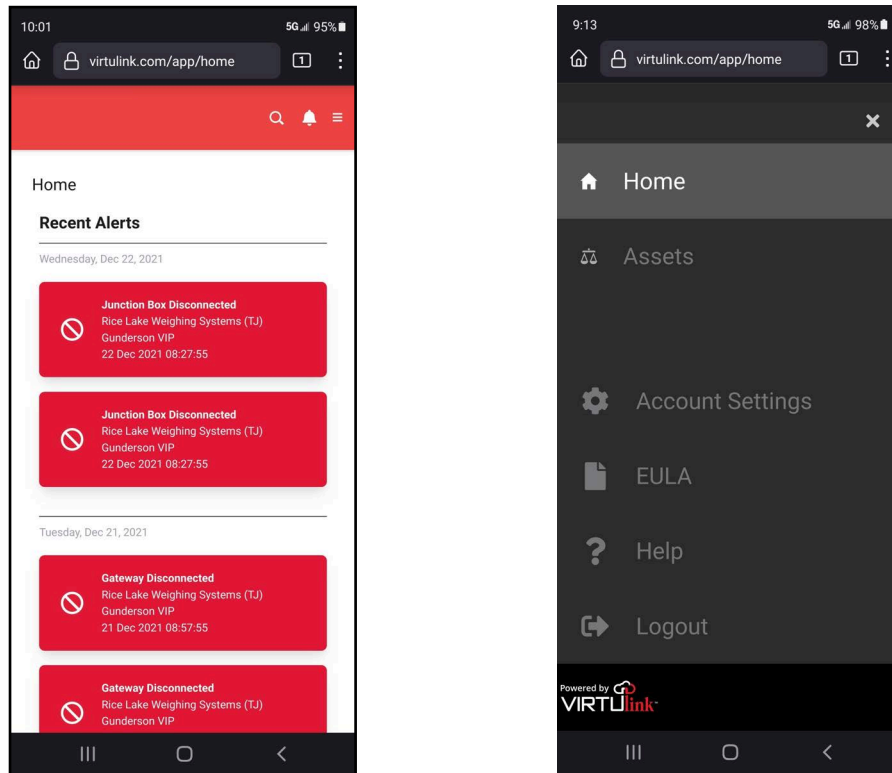

Figure 2-14. Home Page and Menus in Vertical Orientation

2.6 Account Information

2.6.1 Viewing Profile Settings

Perform the following to view Profile Settings:

- 1. Select the **Settings menu**. The Settings menu expands.
- 2. Select the **Edit Profile** option.

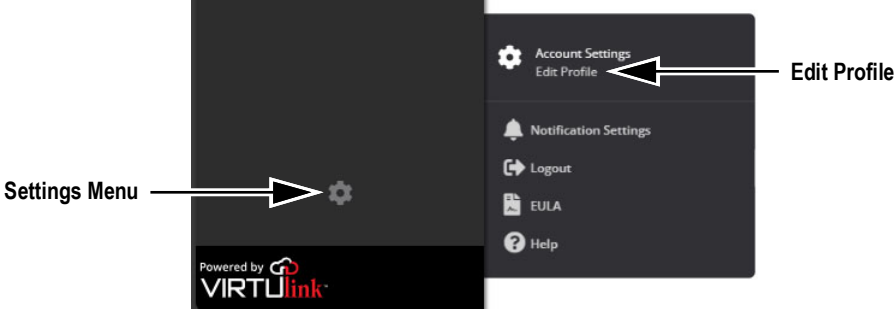

Figure 2-15. Edit Profile Option

- 3. The user profile settings displays.



Figure 2-16. Profile Settings

2.6.2 Editing Profile Settings

To edit Profile Settings, contact VIRTUlinkSupport@RiceLake.com.

2.7 Logout of VIRTUlink

Perform the following to logout from VIRTUlink:

1. Select the **Settings menu** icon. The Settings menu expands.
2. Select **Logout**.

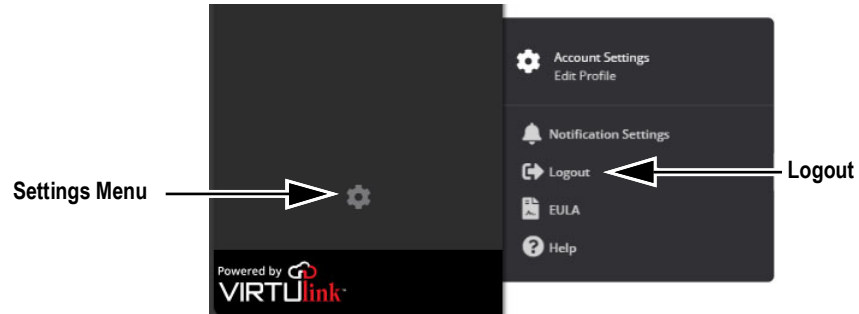

Figure 2-17. Logout Option

3. VIRTUlink logs out and returns to the Login prompt.

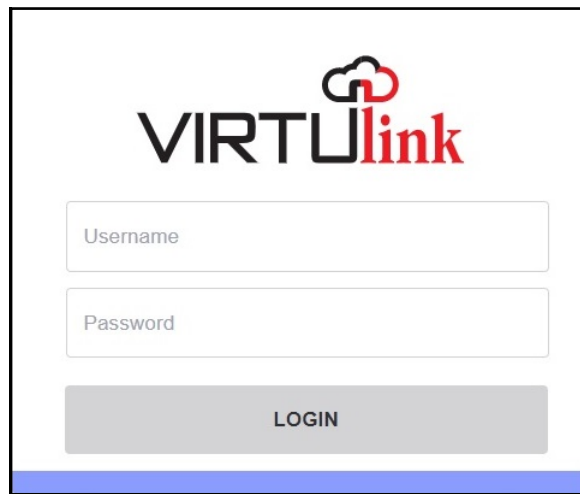

Figure 2-18. Login Prompt

3.0 Configuration

This section discusses configurable features of VIRTUlink, including

- Notification Settings ([Section 3.2 on page 27](#))
- Watch List Configuration ([Section 3.2 on page 27](#))
- Edit VIRTUlink Scale Parameters ([Section 3.3](#))
- Edit VIRTUlink iQUBE Parameters ([Section 3.4](#))

3.1 Notification Settings

3.1.1 Accessing Notification Settings

The Notification Settings menu provides notification customization for each scale.

Perform the following to access Notification Settings:

1. Open the Main menu.
2. Select the **Settings** menu icon.
3. Select **Notification Settings**.

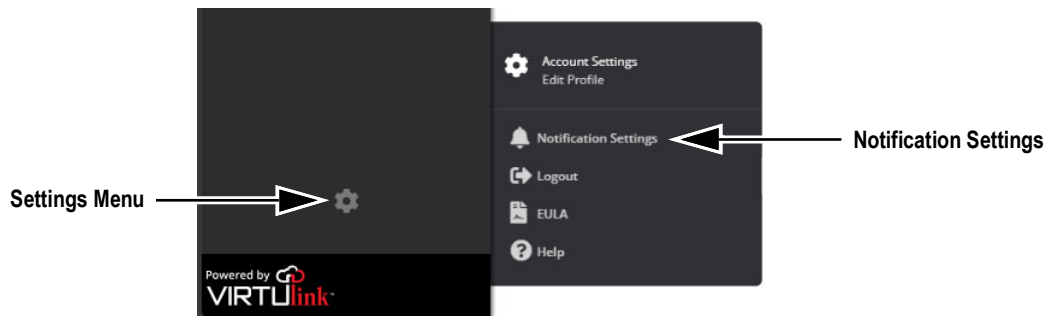

Figure 3-1. Edit Notification Settings Option

4. The Notification Settings page displays.
5. Select the desired scale from the drop-down menu.

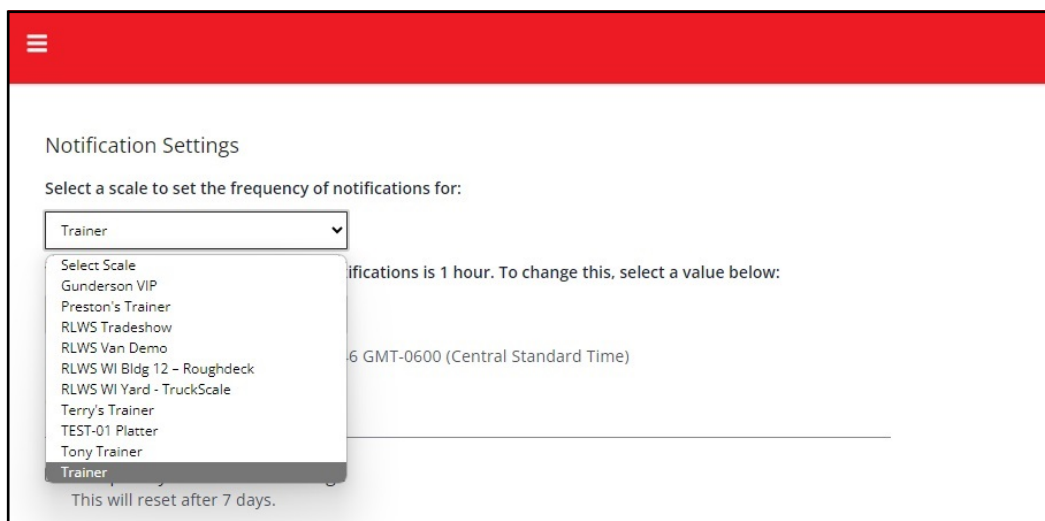

Figure 3-2. Scale Drop-Down Menu Expanded

6. Notification Settings parameters display for the selected scale.

Notification Settings

Select a scale to set the frequency of notifications for:

Trainer

The standard default frequency for notifications is 1 hour. To change this, select a value below:

Select Interval

Last edited at: Fri Dec 15 2023 15:10:58 GMT-0600 (Central Standard Time)
By: tjdealer
Currently set at 1 hour

Temporary Notification Change
This will reset after 7 days.

The standard default frequency for notifications is 1 hour. To change this temporarily, select a value below:

Select Interval

Last edited at: Thu Jan 25 2024 10:18:15 GMT-0600 (Central Standard Time)
By: rlwsadmin
Currently set at 3 hours

Save Disable Temporary Notifications

Figure 3-3. Notification Settings Page with Parameters

3.1.2 Configuring Notifications Setting

The Notification Settings menu provides notification customization for each scale.

Perform the following to configure Notification Settings:

1. Access notification settings and select the desired scale (see [Section 3.1.1 on page 23](#)).
2. (Optional) If configuring a Temporary Notification Change, enable the **Temporary Notification Change** check box.
3. Select the desired interval from either the **Notification Settings** or **Temporary Notification Change** drop-down menus.

Notification Settings

Select a scale to set the frequency of notifications for:

Trainer

The standard default frequency for notifications is 1 hour. To change this, select a value below:

Select Interval

Select Interval

- 1 Hour Interval
- 2 Hour Interval
- 3 Hour Interval
- 6 Hour Interval
- 12 Hour Interval
- 24 Hour Interval

This will reset after 7 days.

The standard default frequency for notifications is 1 hour. To change this temporarily, select a value below:

Select Interval

Last edited at: Fri Jan 26 2024 10:14:55 GMT-0600 (Central Standard Time)
By: tjdealer
Currently set at 6 hours

Save Disable Temporary Notifications

Figure 3-4. Select Interval Drop-Down Menu Expanded

4. Select **Save**. A success indicator displays when the change is completed.



NOTE: Saving may take several seconds to process.

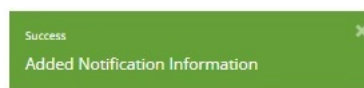

Figure 3-5. Notification Success Indicator

3.1.3 Enable/Disable Temporary Notification Settings

VIRTUlink provides the functionality to enable or disable temporary notifications.

 **NOTE:** In this example temporary notifications are disabled.

1. Access notification settings and select the desired scale (see [Section 3.1.1 on page 23](#)).
2. Select **Disable Temporary Notifications**.

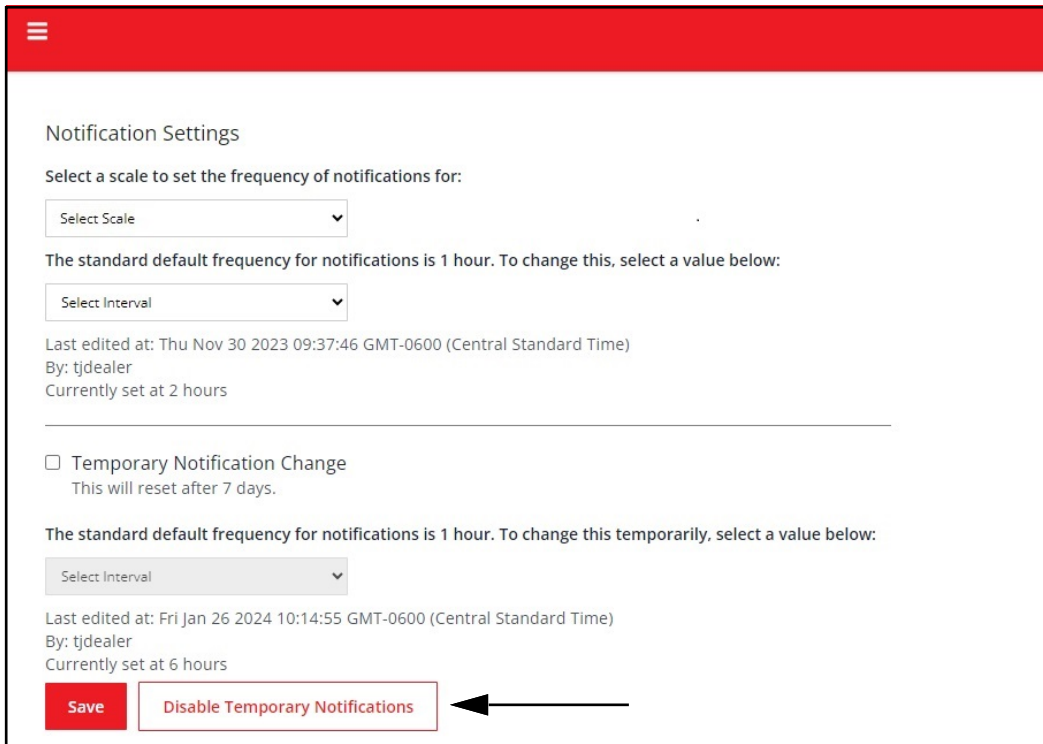

Figure 3-6. Disable Temporary Notification Button

 **NOTE:** In this example temporary notifications are disabled.

3. A success indicator displays stating **Updated Notification Information**.
4. The button changes from Disable Temporary Notifications to Enable Temporary Notifications.

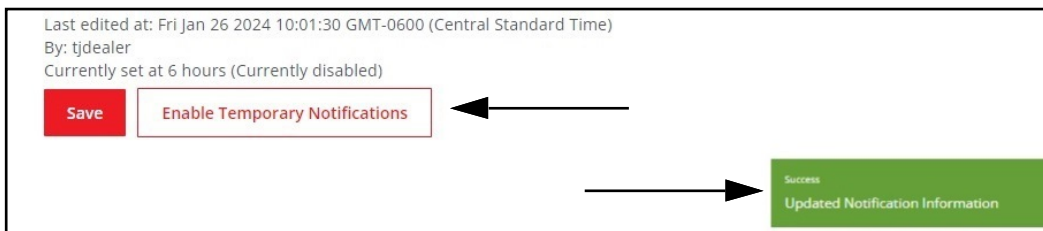

Figure 3-7. Temporary Notifications Disabled

5. Temporary notification are now disabled.
6. Repeat the procedure to enable temporary notifications.



3.2 Watch List Configuration



VIRTUlink provides a Watch List that is viewed on the Home page and configured from the Asset Details page. This feature allows a user to select specific assets that will display in the Watch List on the home page. The Watch List provides status, contact, name and customer information.



NOTE: Watch List configuration is only available to dealers.

Perform the following to add an asset to the Watch List:

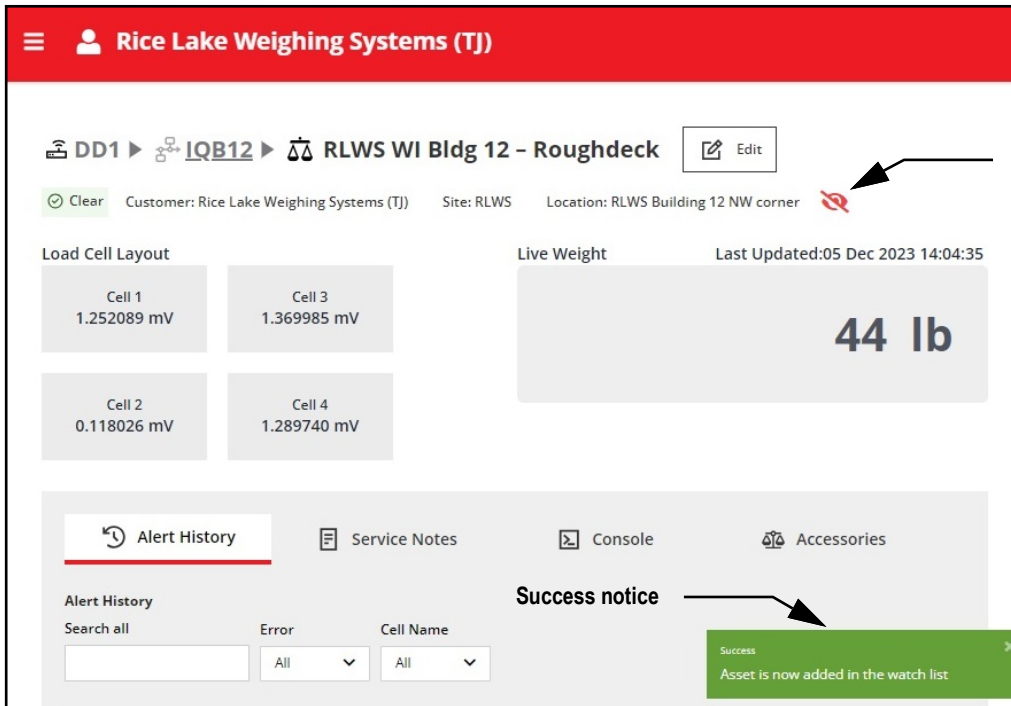

1. Access the desired Asset Details page (see [Section 2.4.3.1 on page 15](#)).
2. Perform one of the following:
 - Select  (eye button) to add asset to the Watch List
 - Select  (eye with slash overlaid button) to remove asset from the Watch list

Example 1: If  (eye button) is selected, the button changes to  (eye with a slash overlaid) and a success indicator momentarily displays. The asset is now added to the Watch List.



The screenshot displays the 'Rice Lake Weighing Systems (TJ)' interface. At the top, the asset name 'DD1' and 'IQB12' are shown, along with 'RLWS WI Bldg 12 - Roughdeck'. Below this, there are fields for 'Clear', 'Customer: Rice Lake Weighing Systems (TJ)', 'Site: RLWS', and 'Location: RLWS Building 12 NW corner'. A 'Live Weight' section shows '44 lb' with a 'Last Updated' timestamp of '05 Dec 2023 14:04:35'. The 'Load Cell Layout' section displays four cells with their respective mV readings: Cell 1 (1.252089 mV), Cell 2 (0.118026 mV), Cell 3 (1.369985 mV), and Cell 4 (1.289740 mV). At the bottom, there are tabs for 'Alert History', 'Service Notes', 'Console', and 'Accessories'. A 'Success notice' is displayed in a green box, stating 'Success Asset is now added in the watch list'.

Figure 3-8. Assets Details Page with Watch List Addition Success Indicator

Example 2: If  (eye button with slash) is selected, the button changes to  and a success indicator momentarily displays. The asset is now removed from the Watch List.

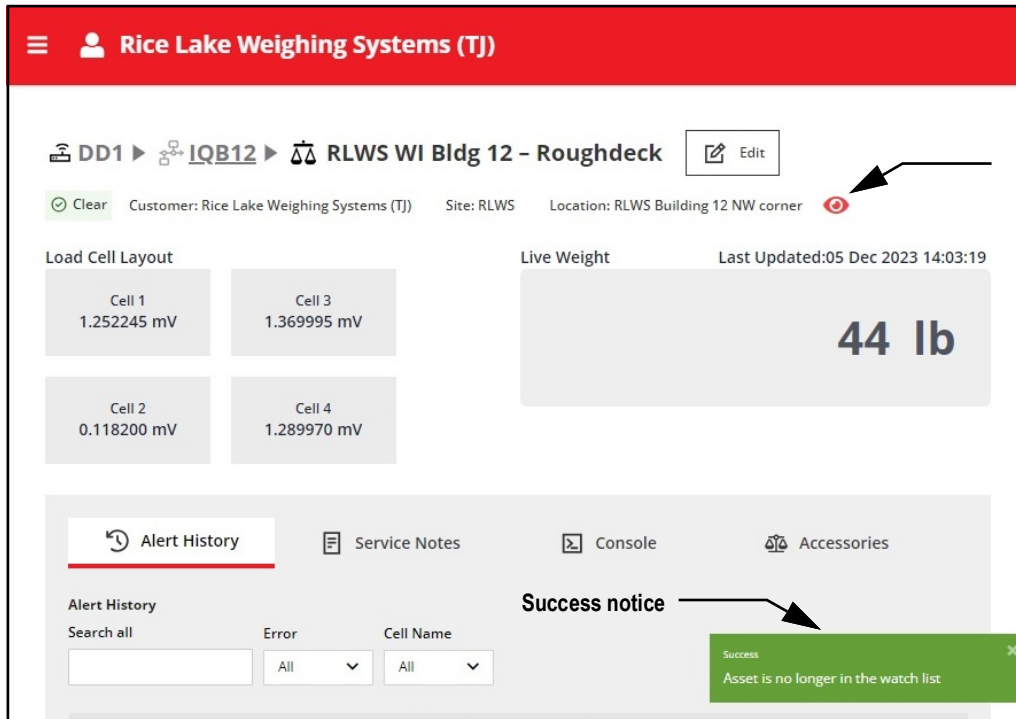

Figure 3-9. Assets Details Page with Watch List Removal Success Indicator

3.3 Edit VIRTUlink Scale Parameters

VIRTUlink provides the functionality to edit scale parameters from the Asset Details Page. Editing scale parameters follows a simple methodology, access the Edit Scale window, edit parameters and save parameters.

Perform the following to edit basic scale parameters:

1. Access the desired Asset Details page (see [Section 2.4.3.1 on page 15](#)).
2. Select the **Edit** (scale) button.

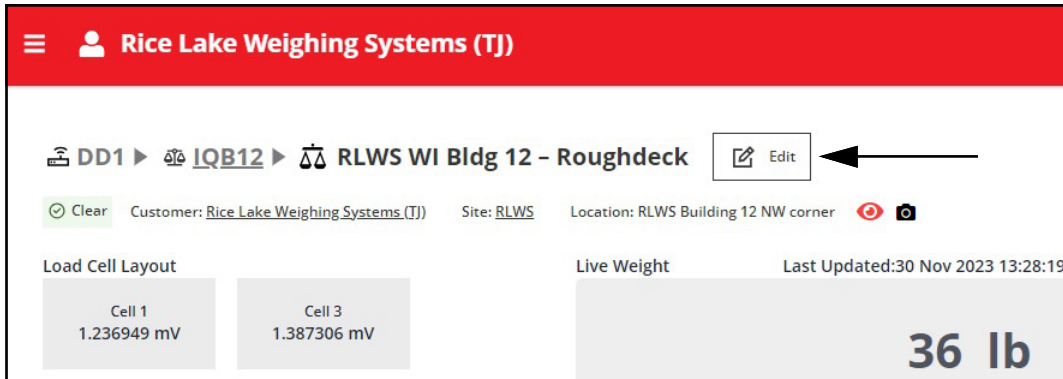

Figure 3-10. Asset Details Page Edit Button

3. The Edit Asset Scale window displays.
4. Edit the following parameters as needed:
 - **Name:** Defines the name of the scale in the VIRTUlink software
 - **Scale Number:** Defines the iQUBE scale number.
 - **WARNING:** Do not change the Scale Number unless instructed to by Rice Lake Weighing Systems Technical Support. Changing the Scale Number can cause operational issues.
 - **Load Cell Quantity:** Defines the quantity of load cells installed in the scale.
 - **Location:** Defines the physical location of the scale.
 - **Scale Type:** Defines the type of scale (truck, floor, bench, tank, other).
 - **iQUBE:** Displays the iQUBE name. The iQUBE name is not editable from this window. For more information, see [Section 3.4 on page 30](#).
 - **Gateway:** Displays the Gateway name. The Gateway name is not editable from this window.

Edit Scale

Name*

Scale Number*

Load Cell Quantity

Location*

Scale Type

Gateway

iQUBE

Figure 3-11. Edit Scale Window

5. Select **Save** to commit changes or **Cancel** to quit without saving.

3.4 Edit VIRTUlink iQUBE Parameters

VIRTUlink provides the functionality to edit basic VIRTUlink iQUBE parameters from the iQUBE Details page. Editing iQUBE² parameters follows a simple methodology, access the Edit iQUBE window, edit parameters and save parameters.

 **NOTE: The Edit iQUBE function is only available to dealers.**

Perform the following to edit basic VIRTUlink iQUBE parameters:

1. Access the desired Asset Details page (see [Section 2.4.3.1 on page 15](#)).
2. Select the **iQUBE** link.

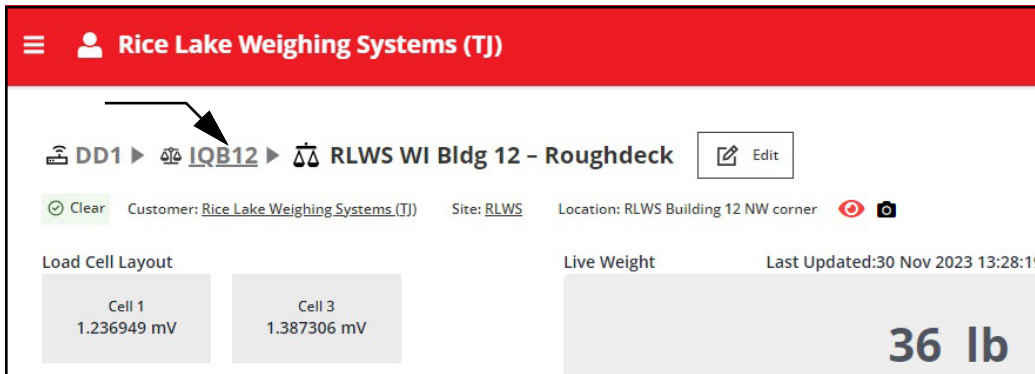

Figure 3-12. Asset Details Page iQUBE Button

3. The iQUBE² details page displays.
4. Select the **Edit** (iQUBE²) button.

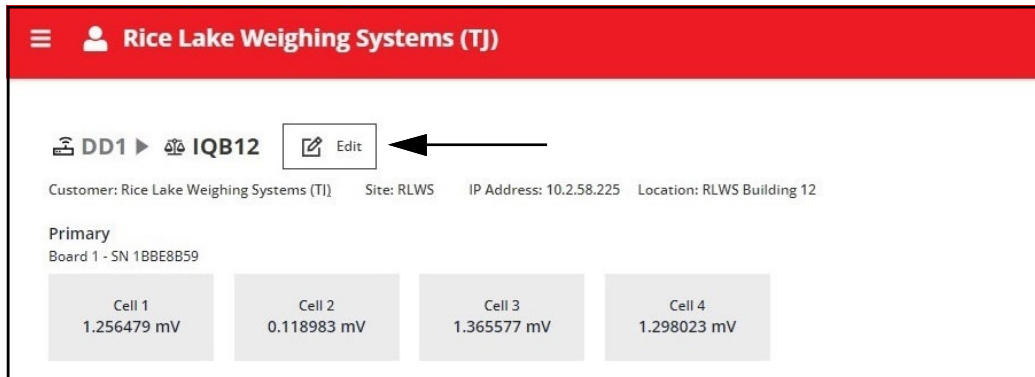

Figure 3-13. iQUBE page with Edit Button

5. The Edit iQUBE window displays.

6. Edit the following parameters as needed:

- Name: Defines the name of the iQUBE in the VIRTUlink software
- IP Address: Defines the IP Address of the iQUBE.



NOTE: The assigned IP address should not require change unless the end-user changes the IP address that was provided when the system was originally setup.

- Serial: Defines the serial number of the iQUBE.
- Number of Boards: Defines the quantity of boards in the iQUBE.
- Location: Defines the physical location of the iQUBE.
- Gateway: Displays the gateway serial number. The gateway serial number is not editable.

Edit iQUBE

Name*
IQB12

IP Address*
10.2.58.225

Serial
Enter your iQUBE serial

Number of Boards
Enter the number of boards

Location*
RLWS Building 12

Gateway
000001321400-000000023111

Cancel Save

Figure 3-14. Edit iQUBE Window

7. Select **Save** to commit changes or **Cancel** to quit without saving.

4.0 Asset Details Page Features

This section discusses functions in the Asset Details page, including:

- Load Cell Details ([Section 4.1 on page 32](#))
- IP Camera ([Section 4.2 on page 34](#))
- Alert History ([Section 4.3 on page 35](#))
- Service Notes ([Section 4.4 on page 37](#))
- Asset Console ([Section 4.5 on page 39](#))
- Accessories ([Section 4.6 on page 40](#))

4.1 Load Cell Details

Load cell details is an informational window accessed from the Asset Details page. The window displays additional details about the selected load cell.

4.1.1 Accessing Cell Details

To access load cell details, perform the following:

1. Access the desired Asset Details page (see [Section 2.4.3.1 on page 15](#)).
2. Select the desired load cell.

Load Cell Layout	
Cell 1 1.252089 mV	Cell 3 1.369985 mV
Cell 2 0.118026 mV	Cell 4 1.289740 mV

Figure 4-1. Load Cells in Asset Details page

3. The load cell details window displays.

Cell Number - 1	
Percentage of Full Load:	0.00% ✓ Clear
Raw A/D Counts:	77
Raw A/D Voltage:	0.43 mV
Serial Number	d9ec676e8211
Model Name	C1234567
Capacity	75000 lbs
Part Number	12345
Zero Value	0
Factory Sensitivity	3 mV
Normalization Value	0

Figure 4-2. Load Cell Details Window

4.1.2 About Load Cell Details Window

The load cell details window provides a variety of fields that display information and dynamic data about the selected load cell.

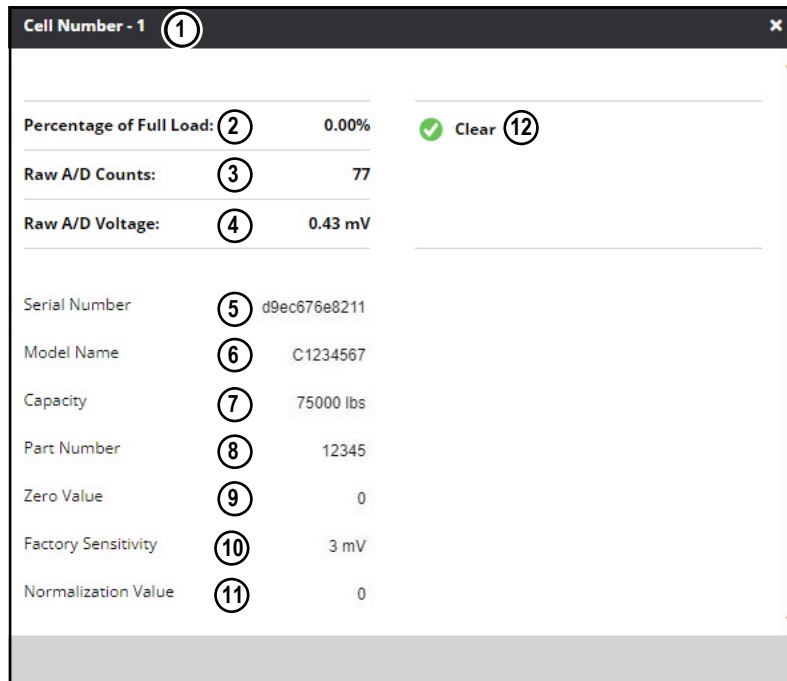

Figure 4-3. Load Cell Details with Elements Identified

Elements identified in the [Figure 4-3](#) are described in the [Table 4-1](#):

Number	Feature	Description
1	Load Cell Number	Lists the load cell number. For more information, see <i>iQUBE² Digital Diagnostic Junction Box Installation Manual (PN 106113)</i>
2	Percentage of Full Load	Lists the percentage of a load measured by this load cell. This aids in assessing a balanced load on a scale. In a four load cell system this value should show about 25% of the total weight value (assuming all applied weight is symmetrically applied). If one of the load cell displays substantially different data it indicates a potential load cell problem.
3	Raw A/D Counts	Lists raw analog to digital counts. Changes in this value could indicate a damaged or failing load cell. Values should be recorded, with the same weight(s) applied, over time.
4	Raw A/D Voltage	Lists the raw analog to digital signal in millivolts (mV).
5	Serial Number	Lists the serial number of load cell (if configured in VIRTUlink).
6	Model Name	Lists the model name of the load cell (if configured in VIRTUlink).
7	Capacity	Lists the weight capacity of load cell (if configured in iQUBE ²).
8	Part Number	Lists the load cell's part number (if configured in VIRTUlink).
9	Zero Value	Displays the currently configured zero value (if configured in VIRTUlink).
10	Factory Sensitivity	Displays the currently configured factory sensitivity in millivolts (mV) (if configured in VIRTUlink).
11	Normalization Value	Displays the currently configured normalization value (if configured in VIRTUlink).
12	Cell Status	Lists the current status of the load cell. Typically a load cell is Clear, in Emulation mode, Overload, Underload, Zero Reference Error, Cell Connection Error, Unbalanced Load Error, Peak Noise, Cell Drift or Disconnected.

Table 4-1. Load Cell Details Elements Description

4.2 IP Camera

The optional IP camera, if configured, provides still images of its associated asset.



NOTE: Rice Lake Weighing Systems sells IP Cameras that are compatible with VIRTUlink, please contact Rice Lake Weighing Systems for details.

For information how to setup an IP Camera, see Adding Assets. Perform the following to access the IP Camera window:

1. Access the desired Asset Details page (see [Section 2.4.3.1 on page 15](#)).
2. Select the **IP Camera** button ().



NOTE: IP camera must be configured for button to appear.

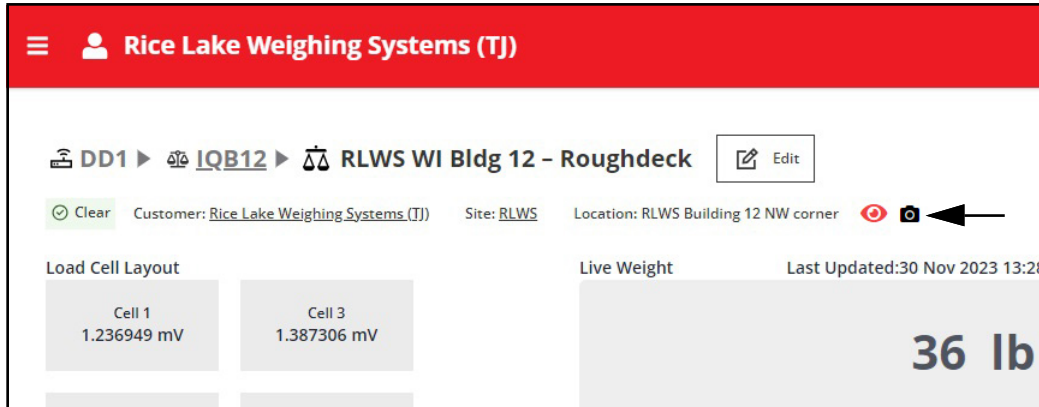

Figure 4-4. IP Camera Button In Asset Details Page

3. The IP Camera window displays (see [Figure 4-5 on page 34](#)).
4. Select the **Refresh** button to display current camera image.



Figure 4-5. IP Camera Window

4.3 Alert History

VIRTUlink monitors the system for alerts generated by components and assets within the system that could cause potential issues. Recent alerts are viewed on the home page and a comprehensive list of all system alerts can be accessed using the Alert History tab in the Asset Details Page.

For information about most alert types, see Diagnostics in the iQUBE² Digital Diagnostic Junction Box Installation Manual (PN 106113).

Alert History may be accessed in two ways:

- Selecting a Recent Alert from the Home page ([Section 4.3.1 on page 35](#))
- Navigating to the Alert History tab in the Asset Details page ([Section 4.3.2 on page 36](#))



NOTE: Gateway Disconnected indicates VIRTUlink has not received messages from the VIRTUlink Gateway for over 30 minutes. Junction Box Disconnected indicates the VIRTUlink Gateway has not received messages from the iQUBE Junction Box for over five minutes.



NOTE: Before a new alert displays in alert history, the asset (scale) must first be in good health (no errors). Once an alert triggers, alert history logs the condition, date, and time of the alert. VIRTUlink only reports the alert when it initially occurs, unless the asset returns to good health and the alert triggers subsequently.

4.3.1 Viewing Recent Alerts on the Home Page



NOTE: The Home page is only available to dealers. For information about how to access Alert History from Asset Details page, see [Section 4.3.2 on page 36](#).

To access Alert History from Recent Alerts on the Home page, perform the following:

1. Select **Home** from the Main menu.

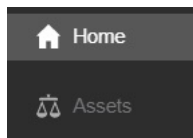

Figure 4-6. Main Menu Home Option

2. The Home page displays.
3. Select the desired alert from the Recent Alerts column.

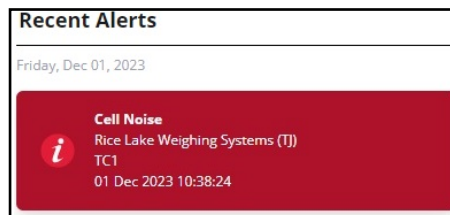

Figure 4-7. Recent Alerts Column

4. The Asset Details page displays with the Alert History selected by default.

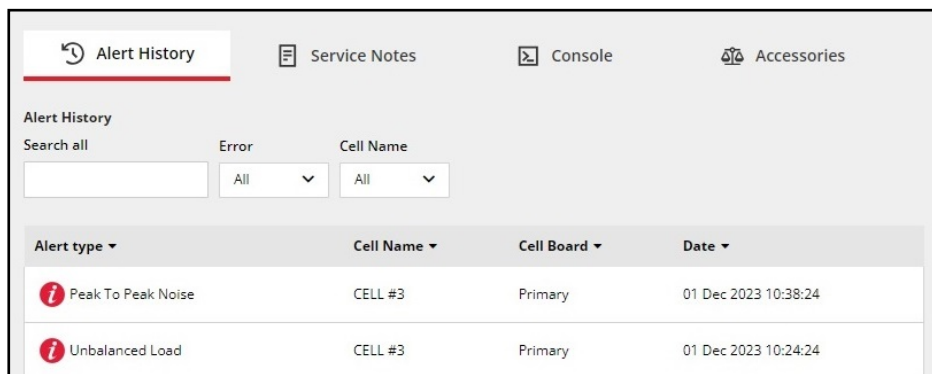

Figure 4-8. Alert History Tab

4.3.2 Viewing Alert History from Asset Details Page

To access Alert History from the Asset Details page, perform the following:

1. Access the desired Asset Details page (see [Section 2.4.3.1 on page 15](#)).
2. The Asset Details page displays with Alert History selected by default.

Alert type	Cell Name	Cell Board	Date
<i>i</i> Peak To Peak Noise	CELL #3	Primary	01 Dec 2023 10:38:24
<i>i</i> Unbalanced Load	CELL #3	Primary	01 Dec 2023 10:24:24
<i>i</i> Unbalanced Load	CELL #4	Primary	01 Dec 2023 10:24:24
<i>i</i> Cell Drift	CELL #3	Primary	01 Dec 2023 10:24:24
<i>i</i> Cell Drift	CELL #3	Primary	30 Nov 2023 15:05:35
<i>i</i> Cell Drift	CELL #3	Primary	30 Nov 2023 15:05:14
<i>i</i> Unbalanced Load	CELL #3	Primary	30 Nov 2023 15:01:59

Figure 4-9. Alert History Tab

4.4 Service Notes

VIRTUlink provides a feature called Service Notes in the Asset Details page. This feature allows a dealer to record and view notes specific to an asset.

Service notes can be added in two ways:

- Through the Service Notes Menu (Section 4.4.1 on page 37)
- By Selecting an Alert in Alert History (Section 4.4.2 on page 38)

4.4.1 Adding Service Notes in the Service Notes Tab

Perform the following to record a service note:

1. Access the desired Asset Details page (see Section 2.4.3.1 on page 15).
2. Select the **Service Notes** tab.
3. Select the **Add Note** button.

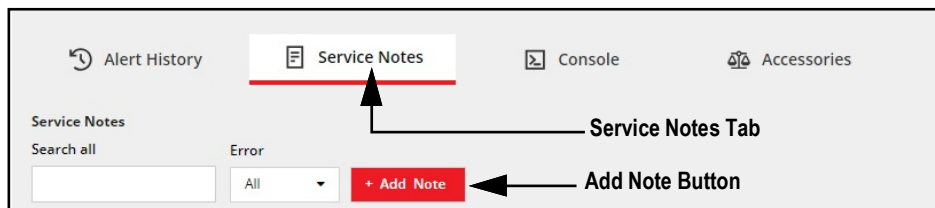

Figure 4-10. Service Notes Tab and Add Note Button

4. The Add Service Note window displays.



NOTE: The Asset ID is automatically generated and not editable. This field lists the Gateway serial number.

5. Enter the desired Title for the service note.

Select the desired type of note from the Type drop-down menu.

6. If necessary, complete additional information fields.
7. Select the **Add Service Note** button.

Figure 4-11. Add Service Note Window with Type Parameter Expanded

8. The service note is added to the Service Notes list.

Service Notes		
Search all	Error	+ Add Note
	All	
DATE	CREATED BY	CELL
Friday, Dec 08, 2023	TJDealer	-
TITLE		
Example		
NOTE		

Figure 4-12. Service Note Added to Service Notes Tab

4.4.2 Adding a Service Note in Alert History

Perform the following to add a service note through an alert:

1. Access Alert history. For more information, see [Section 4.3 on page 35](#).
2. Select the desired Alert.
3. The add Service Note window displays populated with information from the selected alert.
4. Modify the text fields as needed.
5. Select **Add Service Note**.

Figure 4-13. Add Service Note Window

6. The service note is added to the Service Notes list.

DATE	CREATED BY	CELL
Friday, Dec 08, 2023	TJDealer	1

TITLE
Junction Box Disconnected

NOTE
Example

Figure 4-14. Service Note Added to Service Notes Tab

4.5 Asset Console

The Asset Console feature is used in conjunction with electronic data processing (EDP)/serial commands to communicate between VIRTUlink and the iQUBE junction box. The tool can remotely access many parameters, diagnostic settings, and current settings.



NOTE: For more information about EDP commands, review the *iQUBE² Digital Diagnostic Junction Box Installation Manual* (PN106113). For demonstration purposes, the EDP command `VERSION` is used in the example below.

Perform the following to enter an EDP command in the Console:

1. Access the desired Asset Details page (see [Section 2.4.3.1 on page 15](#)).
2. Select the **Console** tab. The Console displays.

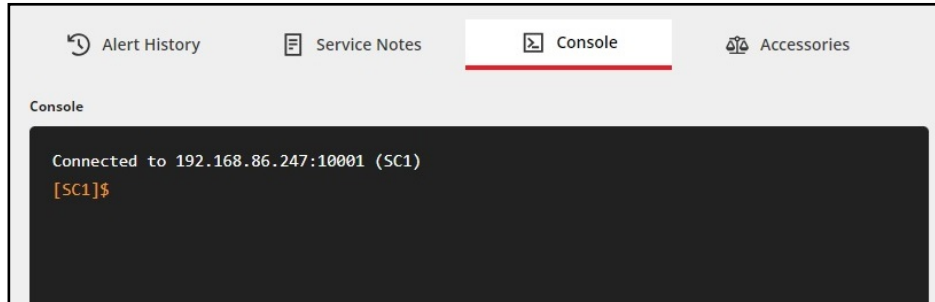

Figure 4-15. Console Tab

3. Type the desired EDP command and press **Enter**. In this example `VERSION` is entered.



NOTE: Some EDP commands are scale specific and require referencing the scale number. The scale number is located adjacent to the IP Address and prompt (`SC1` in this example).

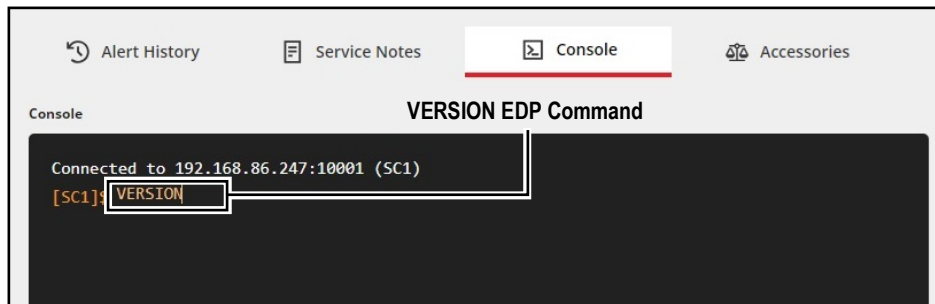

Figure 4-16. Console with Version Command Entered

4. The console outputs a result relevant to the command. In This example the system replies with the iQUBE's firmware version information.

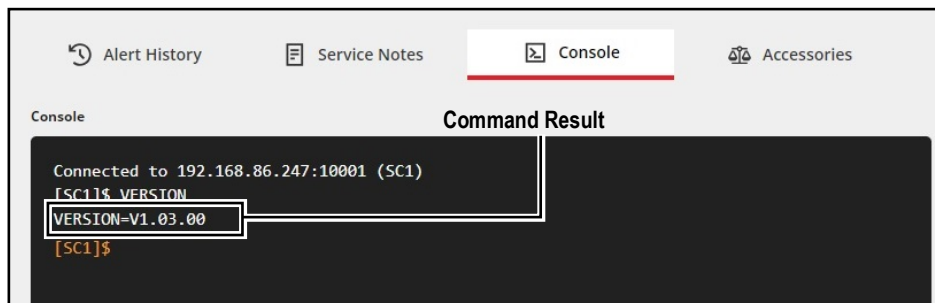

Figure 4-17. Console with Result

4.6 Accessories

The Accessories tab is accessed from an Asset Details Page and displays accessories that are installed on the VIRTUlink system.

Perform the following to view configured accessories:

1. Access the desired Asset Details page (see [Section 2.4.3.1 on page 15](#)).
2. Select the **Accessories** tab. The tab opens and displays accessories configured for the selected Asset. In this example an IP camera is available.
3. Select the accessory button.



NOTE: Selecting the IP Camera button () in the Accessories tab activates the same function as selecting the IP Camera button () near the asset name.

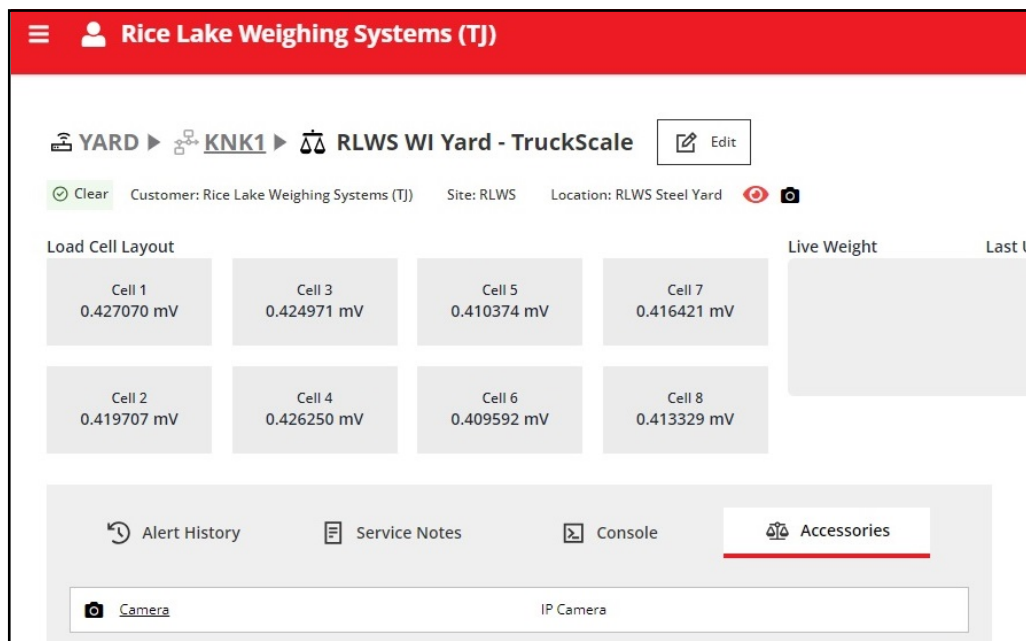

Figure 4-18. Accessories Tab Open

4. The accessory window opens (see [Section 4.2 on page 34](#))

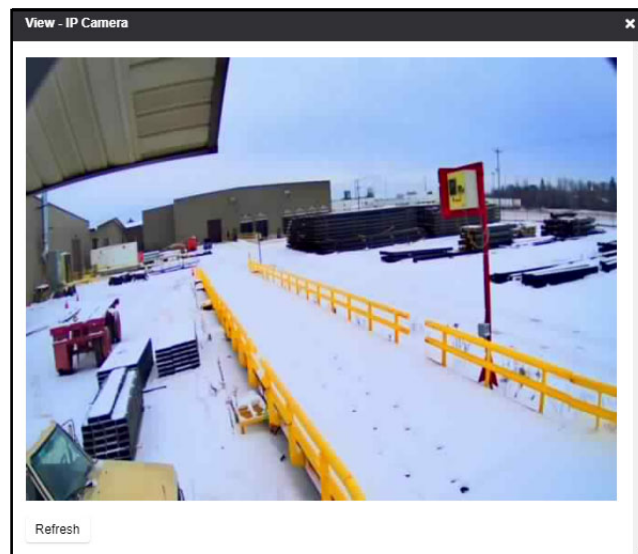



Figure 4-19. IP Camera Window

5.0 Emulation Mode

5.1 Emulation Mode Examples

Load cell emulation allows the output of a failed load cell to be emulated by using the remaining load cells in the system to estimate the value of the failed load cell.

VIRTUlink creates an alert when a load cell enters emulation mode and remains active until emulation mode is disabled. Alerts regarding emulation display on the Home page, Asset Details page, iQUBE page and Load Cell Details.

 **NOTE: Changing emulation mode status is not facilitated by VIRTUlink Consult the iQUBE² Digital Diagnostic Junction Box Installation Manual (PN 106113) or indicator manual for more information.**

The following images display examples of emulation mode in various pages for reference.

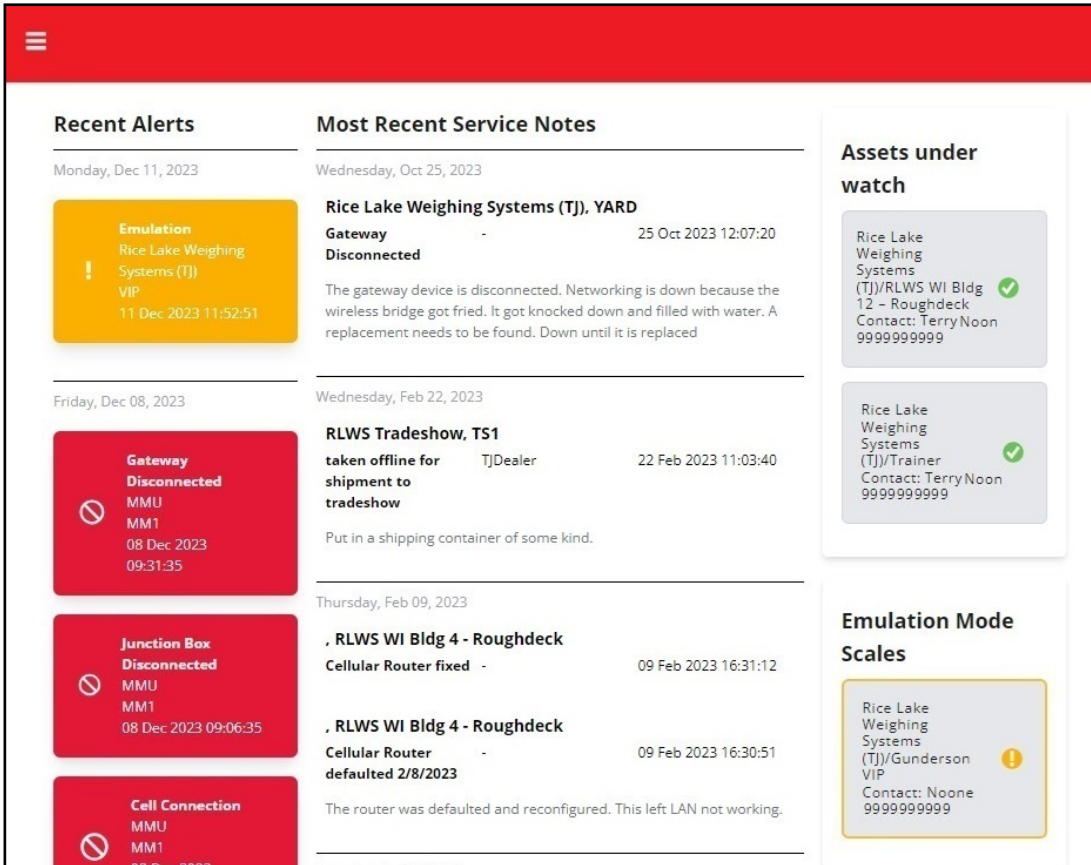

The screenshot displays the VIRTUlink interface with a red header and a white main content area. It is divided into several sections:

- Recent Alerts:**
 - Monday, Dec 11, 2023:** A yellow alert box titled "Emulation" for "Rice Lake Weighing Systems (TJ) VIP" with a timestamp of "11 Dec 2023 11:52:51".
 - Friday, Dec 08, 2023:** A red alert box titled "Gateway Disconnected" for "MMU MM1" with a timestamp of "08 Dec 2023 09:31:35".
 - 08 Dec 2023 09:06:35:** A red alert box titled "Junction Box Disconnected" for "MMU MM1".
 - 08 Dec 2023 09:06:35:** A red alert box titled "Cell Connection" for "MMU MM1".
- Most Recent Service Notes:**
 - Wednesday, Oct 25, 2023:** "Rice Lake Weighing Systems (TJ). YARD Gateway Disconnected" at "25 Oct 2023 12:07:20". Description: "The gateway device is disconnected. Networking is down because the wireless bridge got fried. It got knocked down and filled with water. A replacement needs to be found. Down until it is replaced".
 - Wednesday, Feb 22, 2023:** "RLWS Tradeshow, TS1 taken offline for shipment to tradeshow" at "22 Feb 2023 11:03:40". Description: "Put in a shipping container of some kind.".
 - Thursday, Feb 09, 2023:** "RLWS WI Bldg 4 - Roughdeck Cellular Router fixed" at "09 Feb 2023 16:31:12".
 - 09 Feb 2023 16:30:51:** "RLWS WI Bldg 4 - Roughdeck Cellular Router defaulted 2/8/2023" at "09 Feb 2023 16:30:51". Description: "The router was defaulted and reconfigured. This left LAN not working.".
- Assets under watch:**
 - "Rice Lake Weighing Systems (TJ)/RLWS WI Bldg 12 - Roughdeck" with contact "Terry Noon 999999999" and a green checkmark.
 - "Rice Lake Weighing Systems (TJ)/Trainer" with contact "Terry Noon 999999999" and a green checkmark.
- Emulation Mode Scales:**
 - "Rice Lake Weighing Systems (TJ)/Gunderson VIP" with contact "Noone 999999999" and a yellow warning icon.

Figure 5-1. Emulation Mode in Recent Alerts and Emulation Mode Scales

Assets

Search all Dealership Customer iQube Gateway

Asset	Status	Dealership	Customer	Location	iQube	Gateway
Gunderson VIP	Emulation		Rice Lake Weighing Systems (TJ)	Lester B Gunderson VIP room	IQVIP	VIP
Roughdeck	Clear		Rice Lake Weighing Systems (TJ)	Obeya 1	Pres	DD2
RLWS Tradeshow	Disconnected		RLWS Tradeshow	Obeya 2	IQT1	TS1
RLWS Van Demo	Disconnected		MMU	Obeya 2	IQM1	MM1
RLWS WI Bldg 12 - Roughdeck	Clear		Rice Lake Weighing Systems (TJ)	RLWS Building 12 NW corner	IQB12	DD1
RLWS WI Yard - TruckScale	Clear		Rice Lake Weighing Systems (TJ)	RLWS Steel Yard	KNK1	YARD
RLWS WI Yard - TruckScale 2	Clear		Rice Lake Weighing Systems (TJ)	RLWS Steel Yard	IQTC	TC1
Platter	Clear		Rice Lake Weighing Systems (TJ)	Platter in Obeya 1	Platter	DD2
Platter2	Clear		Rice Lake Weighing Systems (TJ)	Platter in Obeya 2	Ton	DD2
Trainer	Clear		Rice Lake Weighing Systems (TJ)	Obeya 1	IQTT	DD2

10 1-10 of 10

Figure 5-2. Emulation Mode in Assets Page

Rice Lake Weighing Systems (TJ)

VIP IQVIP Gunderson VIP

Emulation Customer: Rice Lake Weighing Systems (TJ) Site: RLWS Location: Lester B Gunderson VIP room

Load Cell Layout

Cell 1 5.135575 mV	Cell 3 Emulated
Cell 2 5.140563 mV	Cell 4 4.864919 mV

Live Weight Last Updated: 11 Dec 2023 11:57:51

49820 lb

Alert History Service Notes Console Accessories

Alert History

Search all Error Cell Name

Alert type	Cell Name	Cell Board	Date
Emulation	CELL #3	Primary	11 Dec 2023 11:52:51
Cell Overload	CELL #2	Primary	06 Dec 2023 14:49:48

Figure 5-3. Emulation Mode in Asset Details

Rice Lake Weighing Systems (TJ)

VIP IQVIP Edit

Customer: Rice Lake Weighing Systems (TJ) Site: RLWS IP Address: 10.2.58.144 Location: Lester B Gunderson VIP room

Primary
Board 1 - SN 1D2A8527

Cell 1 5.136247 mV	Cell 2 5.139652 mV	Cell 3 Emulated	Cell 4 4.864404 mV
-----------------------	-----------------------	--------------------	-----------------------

Figure 5-4. Emulation Mode in iQUBE Page

Cell Number - 3

Percentage of Full Load:	0.00%	! Emulation
Raw A/D Counts:	-21756	
Raw A/D Voltage:	0.00 mV	
Serial Number	S/N#3	
Model Name		
Capacity	75000 lbs	
Part Number		
Zero Value		
Factory Sensitivity		
Normalization Value		

Figure 5-5. Emulation Mode Cell Details Example

6.0 Troubleshooting

6.1 Error Messages

In rare circumstances an error may occur during normal VIRTUlink use.

Figure 6-1 illustrates a common error message that may occur in VIRTUlink. In most cases the error is resolved by selecting the Try Again button or the web browser's refresh button.

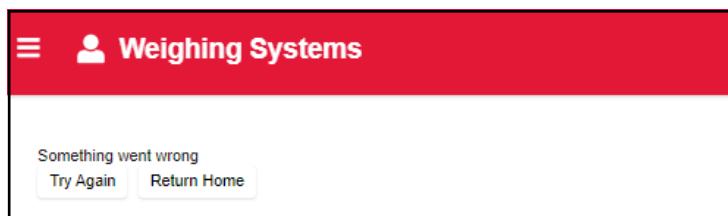

Figure 6-1. Error Message Example

6.2 Error Email Messages

You may receive an email message prompting you to review a system alert or to take an action. Typically this is result of a hardware error (for instance: disconnection, overload, underload, drift, emulation, etc). In most cases these errors are resolved following standard service or diagnostic procedures.

Figure 6-2 illustrates an error email message example:

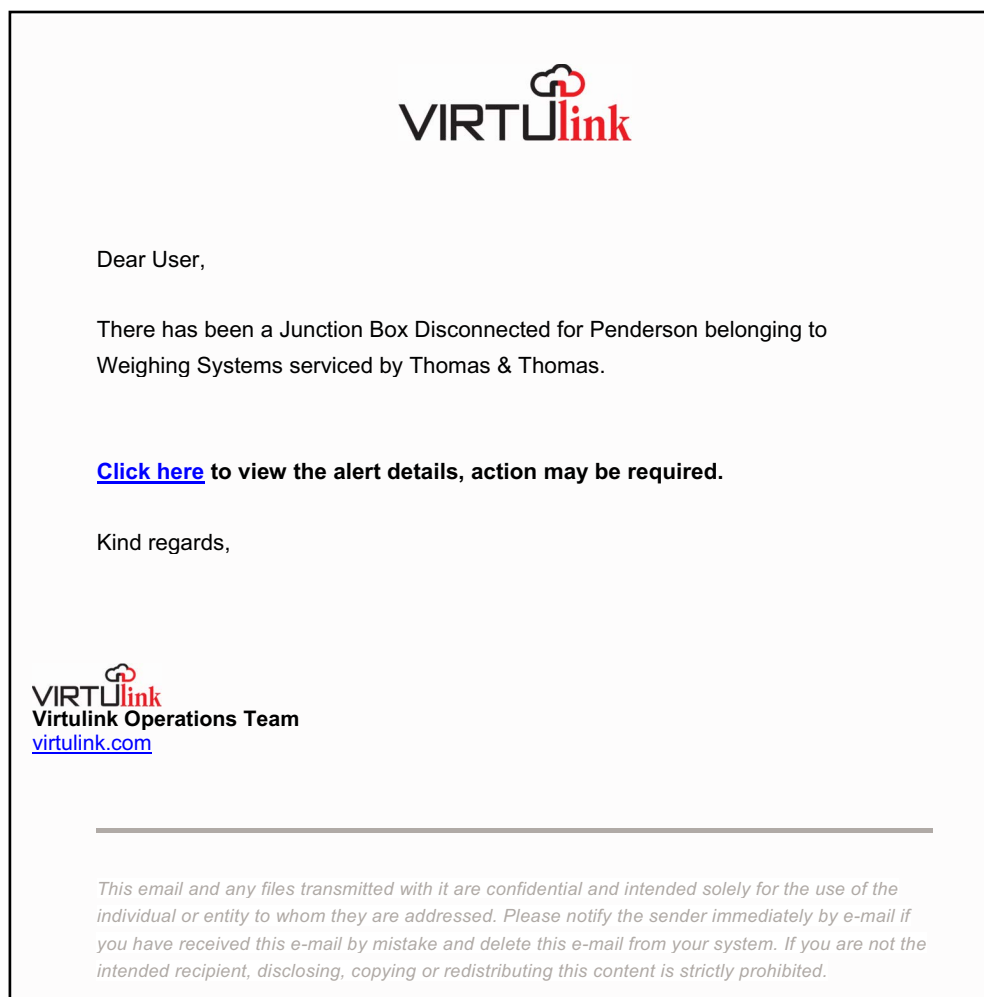

Figure 6-2. Email Error Message

6.3 Gateway Status LEDs

The gateway provides several status LEDs that indicate various system states.



Figure 6-3. Gateway LEDs

LED	Description
ERR NS	Unused (should be illuminated red)
RUN MS	Unused (should be extinguished)
APL	Unused (should be extinguished)
SYS	Illuminates solid green when the gateway is operating correctly
LED1	Unused (should be extinguished)
LED2	Unused (should be extinguished)
ACT	Flashes green during normal operation
POW	Illuminates solid green when supplied power is within operating parameters
ACT / RX / TX (Yellow Ethernet Port LED)	Flashes yellow when the gateway is sending/receiving network frames. Extinguishes when there is no network traffic
LINK (Green Ethernet Port LED)	Illuminates green when the gateway has a 100 MBit network connection. Extinguishes when the gateway has 10 MBit or no network connection

Table 6-1. Gateway LED Descriptions



© Rice Lake Weighing Systems Content subject to change without notice.

230 W. Coleman St. • Rice Lake, WI 54868 • USA USA: 800-472-6703 • International: +1-715-234-9171