

SCT Ethernet Option Card/ SCT-1000ETHERNET/ SCT-2200WIFI

Ethernet, Modbus TCP, Wi-Fi

Configuration Manual

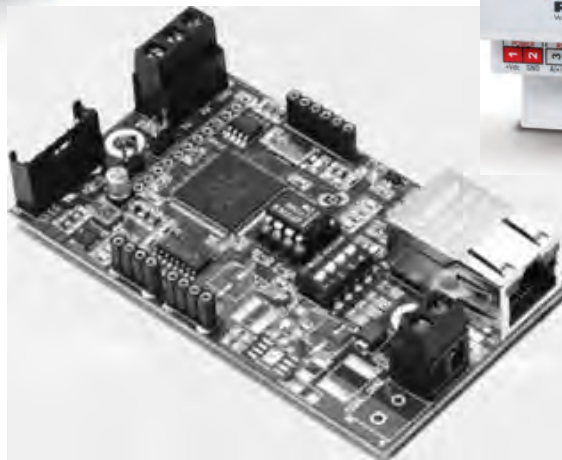

RICE LAKE[®]
WEIGHING SYSTEMS

An ISO 9001 registered company
© Rice Lake Weighing Systems. All rights reserved.

Rice Lake Weighing Systems® is a registered trademark of
Rice Lake Weighing Systems.

All other brand or product names within this publication are trademarks or
registered trademarks of their respective companies.

All information contained within this publication is, to the best of our knowledge, complete and
accurate at the time of publication. Rice Lake Weighing Systems reserves the right to make
changes to the technology, features, specifications and design of the equipment without notice.

The most current version of this publication, software, firmware and all other product
updates can be found on our website:

www.ricelake.com

Contents

1.0	Introduction	1
1.1	Safety	1
2.0	Setup	3
2.1	Module Connection to SCT-2200 Transmitters	3
2.1.1	RS-485 Connection	3
2.1.2	Making an RS-485 Connection	4
2.2	Electrical Diagrams	5
2.2.1	Ethernet/Wi-Fi Option Card Connections	5
2.2.2	SCT-1000 Ethernet Module	5
2.3	Configuring PC to communicate with Module	6
2.3.1	Setting the IP address for Ethernet connections	6
2.3.2	Setting up Wi-Fi	7
3.0	SCT-1000 Ethernet Module Parameters	8
3.1	Status and Configuration	8
3.2	General Settings	9
3.2.1	IP Address Selection	9
3.2.2	General Configuration Settings	9
3.2.3	Restore Factory Defaults	10
3.3	Port Settings	11
3.3.1	232-LAN/WLAN Configuration	11
3.3.2	485-LAN/WLAN Configuration	11
3.3.3	UDP Port Configuration	12
3.3.4	Tunneling Mode	12
3.3.5	Double Tunneling Mode	13
3.3.6	Broadcast Mode	13
3.3.7	TCP Port Configuration	13
3.3.8	Serial Port Configuration	14
3.4	WiFi (Optional)	14
3.5	Password Setting	14
3.6	Manually Changing the Functioning Mode	15
3.7	Resetting the SCT-1000 Ethernet	16
3.7.1	Close the DFLT jumper	16
3.7.2	Manually change functioning mode	16
3.7.3	Restore factory defaults from web browser	16
4.0	SCT-2200 Wi-Fi Module Parameters	17
4.1	Status and Configuration	17
4.2	NetMode	18
4.2.1	Default Mode	18
4.2.2	Serial to Ethernet	19
4.2.3	Serial to Wi-Fi CLIENT	19
4.2.4	Serial to Wi-Fi AP	20
4.3	Serial Settings	21
4.3.1	TCP Server	22
4.3.2	TCP Client	22
4.3.3	UDP Server	22
4.3.4	UDP Client	23



Technical training seminars are available through Rice Lake Weighing Systems. Course descriptions and dates can be viewed at www.ricelake.com/training or obtained by calling 715-234-9171 and asking for the training department.

4.4	Administration	23
4.4.1	System Management	23
4.4.2	Settings Management	24
5.0	Specifications	25
5.1	Ethernet Option Card and SCT-1000 Ethernet Specifications	25
5.2	SCT-2200 Wi-Fi Specifications	26
6.0	Compliance	27



Rice Lake continually offers web-based video training on a growing selection of product-related topics at no cost. Visit www.ricelake.com/webinars

1.0 Introduction

This manual is intended for use by service technicians responsible for configuring the following modules:

- Built-in Ethernet / WiFi option card for SCT indicators
- The following DIN rail mounted network communication modules for SCT-2200 indicators:
 - SCT-1000 Ethernet
 - SCT-2200 Wi-Fi



Manuals and additional resources are available from the Rice Lake Weighing Systems website at www.ricelake.com

Warranty information can be found on the website at www.ricelake.com/warranties

1.1 Safety

Safety Signal Definitions:



Indicates an imminently hazardous situation that, if not avoided, will result in death or serious injury. Includes hazards that are exposed when guards are removed.



Indicates a potentially hazardous situation that, if not avoided, could result in serious injury or death. Includes hazards that are exposed when guards are removed.



Indicates a potentially hazardous situation that, if not avoided, could result in minor or moderate injury.



Indicates information about procedures that, if not observed, could result in damage to equipment or corruption to and loss of data.

General Safety



Do not operate or work on this equipment unless this manual has been read and all instructions are understood. Failure to follow the instructions or heed the warnings could result in injury or death. Contact any Rice Lake Weighing Systems dealer for replacement manuals.



Failure to heed could result in serious injury or death.

Electric shock hazard!

The units have no power switch, to completely remove power from the units, disconnect the power source.

Always disconnect from main power before performing any work on the device.

Do not allow minors (children) or inexperienced persons to operate this unit.

Do not operate without all shields and guards in place.

Do not use for purposes other than weighing applications.

Do not place fingers into slots or possible pinch points.

Do not use this product if any of the components are cracked.

Do not make alterations or modifications to the unit.

Do not remove or obscure warning labels.

Do not use near water, avoid contact with excessive moisture.

The Ethernet and Wi-Fi modules add the following communication functions to the indicator, See [Section 5.1 on page 25](#) for full specifications:

Device Name	Functions
SCT Ethernet/Wi-Fi Option Card	1 RS-485 bidirectional port for connection to SCT-2200 1 RS-232 bidirectional port for connection to SCT-2200 1 Ethernet port for connection to PC/PLC Allows the following conversions: <ul style="list-style-type: none"> • RS-232 ↔ Ethernet • RS-485 ↔ Ethernet • RS-232 ↔ RS-485 • MODBUS TCP ↔ Ethernet • RS-485 ↔ Wi-Fi
SCT-1000 Ethernet	1 RS-485 bidirectional port for connection to SCT-2200 1 RS-232 bidirectional port for connection to SCT-2200 1 Ethernet port for connection to PC/PLC Allows the following conversions: <ul style="list-style-type: none"> • RS-232 ↔ Ethernet • RS-485 ↔ Ethernet • RS-232 ↔ RS-485 • MODBUS TCP ↔ Ethernet
SCT-2200 Wi-Fi	2 RS-485 bidirectional ports for connection to SCT-2200 1 RS-232 bidirectional port for connection to SCT-2200 1 LAN port 1 WAN port 1 SMA port for Wi-Fi Allows the following conversions: <ul style="list-style-type: none"> • RS-485 ↔ Wi-Fi • RS-485 ↔ Ethernet

Table 1-1. Device Functions

LED Definitions

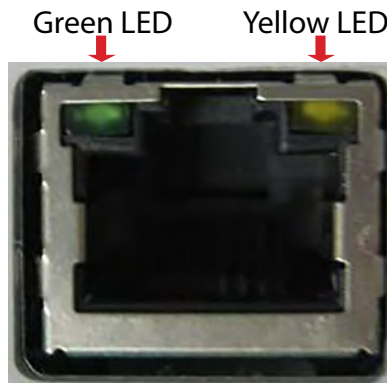

Figure 1-1. Module LEDs

	Green	Yellow
SET NUMBER OF BLINKS	At startup: indicates the module is ON When module is on: indicates the presence of serial activities	
OFF	Network cable not connected	
FIXED	Device connected to network	N/A
CONTINUOUS BLINKING	N/A	Presence of network activity

Table 1-2. LED Definitions

2.0 Setup

2.1 Module Connection to SCT-2200 Transmitters

The Ethernet/Wi-Fi option card is a board that comes installed in an indicator when it is delivered from the factory. Its location will depend on the indicator in which it is installed. It allows the indicator to be connected to Ethernet and WiFi without any additional modules. The SCT-1000 Ethernet Module and the SCT-2200 WiFi module are both independent modules which can be mounted on a DIN rail and must be connected to an indicator through an RS485 connection.

2.1.1 RS-485 Connection

It is possible to connect up to 32 devices on the same RS-485 line.

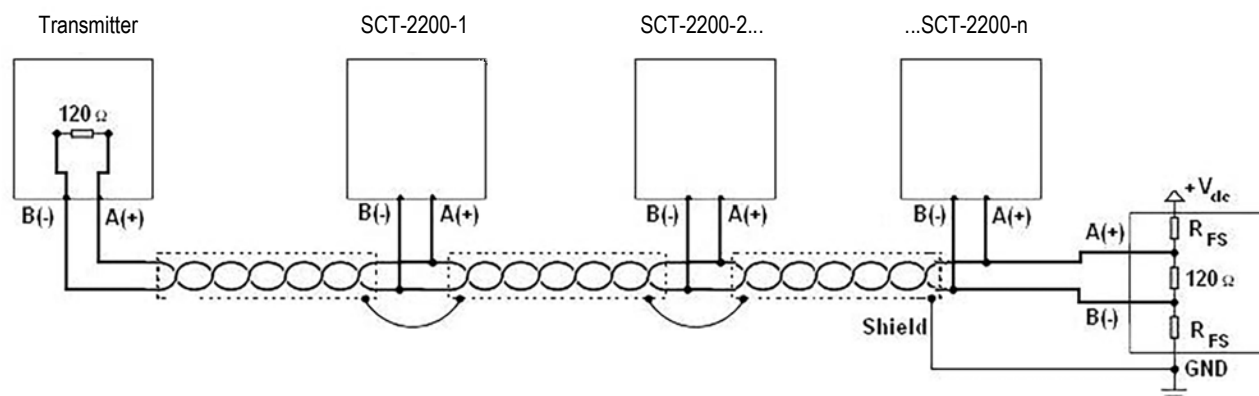

Figure 2-1. Electrical Diagram of RS-485 Connection

- Use an STP (Shield Twisted Pair) cable to make the connection. STP Cable - 2x24 AWG twisted and shielded pair(s). Single shielding for each pair is provided through foil wrap and total shielding through conduit.
- Using the appropriate cable for RS-485 connections, the maximum line length is about 1200 meters.
- As cable length increases, the cable capacity (near 50pF/m) becomes a major factor in power consumption and increases as speed increases.
- This means that the maximum distance cannot be covered with the maximum possible speed. For approximate values, consult the table below:

Baud Rate	Total Capacity of Cable (pF)
1200	400000
2400	200000
4800	100000
9600	50000
19200	25000
38400	12000
57600	8000
115200	4000

Table 2-1. Baud Rate and Cable Capacity



Note When the SCT-1000 Ethernet is set up to use Modbus TCP, it is only capable of communicating with one SCT2200.

2.1.2 Making an RS-485 Connection

1. Verify that the grounding satisfies the SCT-2200 requirements. See the SCT-2200 Operating Manual (PN 183522). Connect all of the digital and analog masses and power circuits to the grounding bar, and connect the grounding bar to the earth ground.
2. The shielding can be connected to a single point in the network (as shown in [Figure 2-1 on page 3](#)) or at both ends, however, it is important that all the devices have the same potential in order to avoid forming ground rings.
3. Connect two termination resistances equal to the characteristic impedance of the cable (typically 120 Ω , see [Figure 2-1 on page 3](#)). Only connect the two devices at the two ends of the ring connection (Example: indicator and last device). The terminal resistance is not supplied with the ports of the indicator.
4. The difference of potential between the A(+) and B(-) terminals in rest conditions (Example: in set-up phase) must be at least 0.2 V.
5. To create a resistive divider which maintains this difference of potential when all the transmitters are disabled, insert in the RS-485 port where the termination resistances are located the polarization or fail-safe resistances (R_{FS} in [Figure 2-1 on page 3](#)). The value of these resistances is between 390 Ω and 2.2 k Ω .



Note The value of these resistances must be greater than the value calculable through the formula below:

$$R_{FS} = \frac{R_{eq}}{2} \times \left(\frac{V_{dc}}{0.2} - 1 \right)$$

V_{dc} = The power supply voltage of the line

R_{eq} = The overall resistance to the A(+) and B(-) between the lines, supplied by the parallel of the two termination resistances and all the input resistances of the devices connected to the bus.

Example:

Assume that a connection has 120 Ω as termination resistance and 32 connected devices, each with an input impedance of 12 k Ω . The V_{dc} power supply is 5 V, and calculate R_{eq} to be about 52 Ω . After plugging these numbers into the equation, R_{FS} must be at least equal to 624 Ω .

If connecting with non-RLWS devices:

- Be aware that lines may be marked differently. Generally the A/B markings correspond to the +/- and HI/LO markings, but this is not always the case. Therefore if the device does not function properly, try inverting the connections.



Note The option card and the SCT-1000Ethernet module have a built in resistor that can be activated by switching the fourth DIP switch to the ON position. See [Figure 2-2](#)

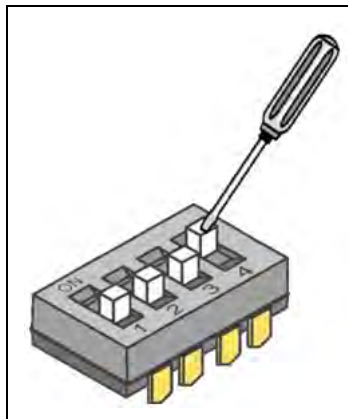

Figure 2-2. Fourth DIP switch on

2.2 Electrical Diagrams

2.2.1 Ethernet/Wi-Fi Option Card Connections

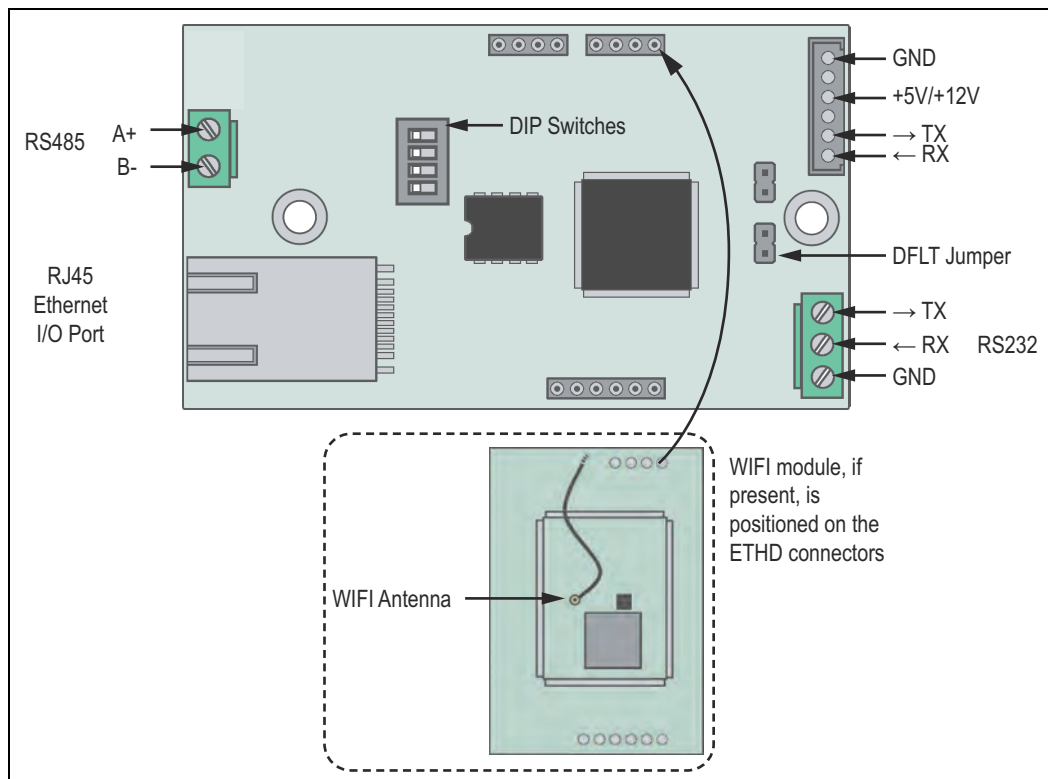

Figure 2-3. ETHD Connectors

2.2.2 SCT-1000 Ethernet Module

Once the SCT-1000 Ethernet module is integrated into the SCT-2200 indicators, it can be connected to an external Ethernet cabling using an external RJ-45 connector. We recommend using a network surge suppressor (PN 72682) wired through a cord grip with the RJ-45 socket left outside of the enclosure.

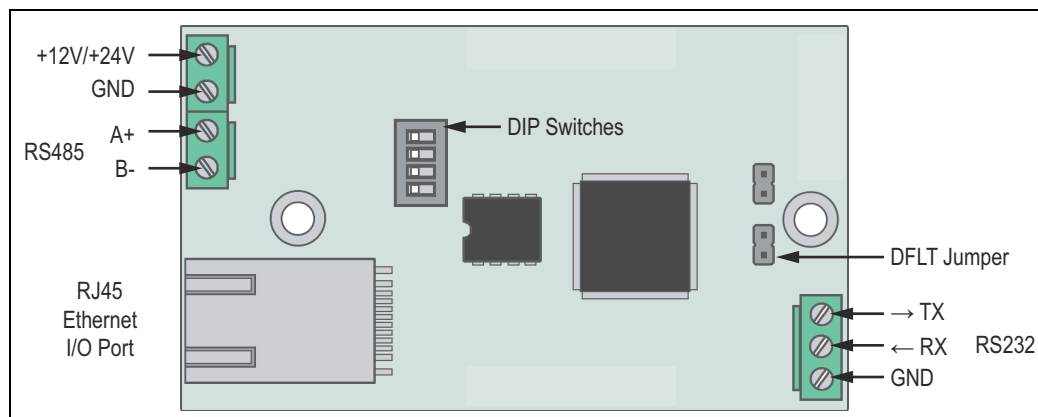

Figure 2-4. SCT-1000 Ethernet Module

The SCT-2200 Wi-Fi can be configured through a web browser using either Wi-Fi capability or the external Ethernet cabling with an external RJ-45 connector. We recommend using a network surge suppressor (PN 72682) wired through a cord grip with the RJ-45 socket left outside of the enclosure.

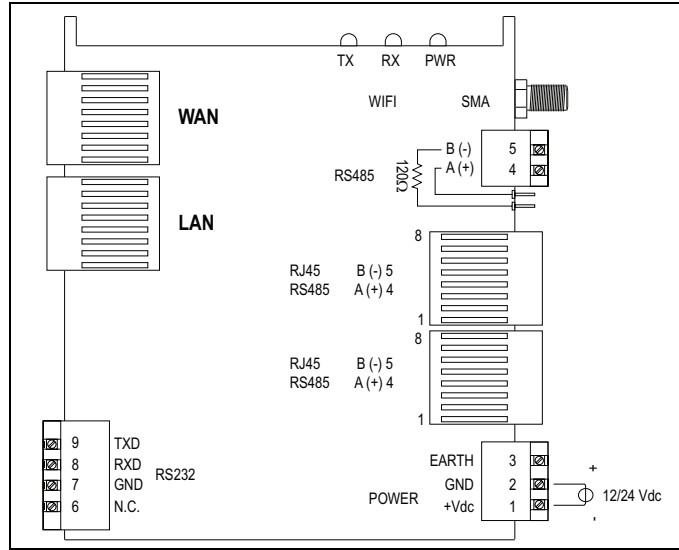

Figure 2-5. SCT-2200 Wi-Fi Electrical Diagram

2.3 Configuring PC to communicate with Module

2.3.1 Setting the IP address for Ethernet connections

Both the SCT-2200 Wi-Fi and the SCT-1000 Ethernet module have Ethernet capability and will be automatically recognized when hardwired into a network.

- The default IP address of the SCT-2200 Wi-Fi is 192.168.16.254.
- The default IP address of the SCT-1000 Ethernet is 192.168.16.205.

The computer Ethernet port must belong to the same class of network for the module to be recognized on the network (in this case, the network must have an IP address of the type 192.168.16.xxx). To modify the IP address in Windows 10 follow these steps:

1. From the Start menu, select Settings. See step 1 in [Figure 2-6](#).
2. In Windows Settings, select Network and Internet. See step 2 in [Figure 2-6](#).
3. In Network and Internet, select Ethernet, then select Change Adapter Options. See step 3 in [Figure 2-6](#).

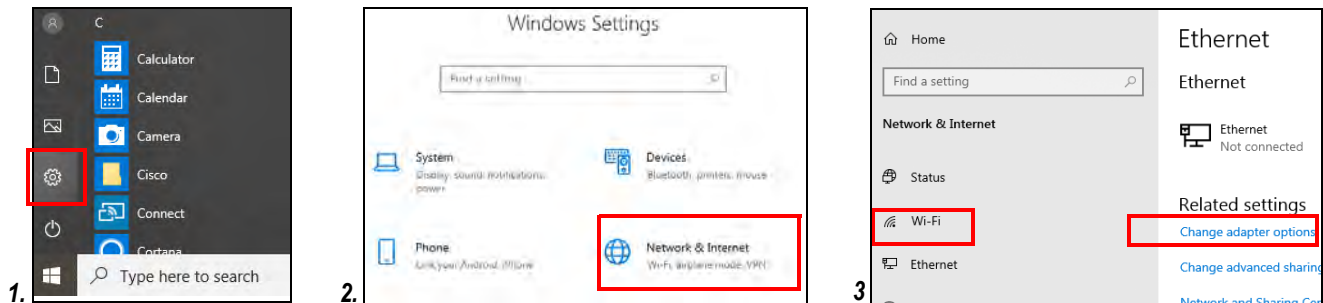

Figure 2-6. Setting IP Address

4. In the Network Connections window, double click Ethernet. See [Figure 2-7](#).

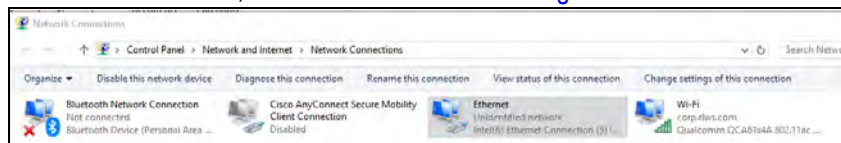

Figure 2-7. Network Connections

5. In Ethernet Status, click Properties. See step 5 in [Figure 2-8](#).
6. Highlight Internet Protocol Version 4 (TCP/IPv4) and click Properties. See step 6 in [Figure 2-8](#).
7. Toggle **Use the following IP address**. See step 7 in [Figure 2-8](#).
 - Enter any IP address between 192.168.16.0 and 192.168.16.255, except 192.168.16.205 or 192.168.16.254
 - Subnet mask is 255.255.255.0
 - Gateway is empty
8. Click ok and close on all open windows to enable static IP address.

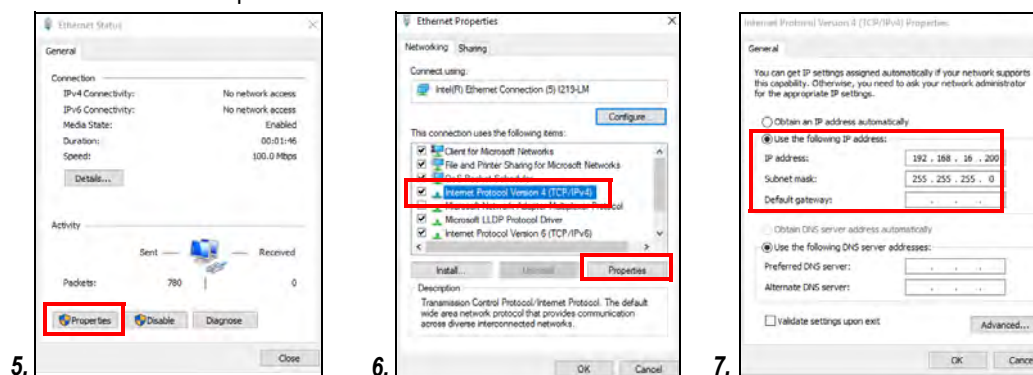

Figure 2-8. Ethernet Status

2.3.2 Setting up Wi-Fi

When the SCT-2200 Wi-Fi has been connected to power it will automatically begin transmitting a Wi-Fi signal. See [Figure 2-9](#).

- Default SSID is HI-LINK_5C53
- Default password is 12345678

To reset the SSID and password, See [Section 4.3 on page 21](#).

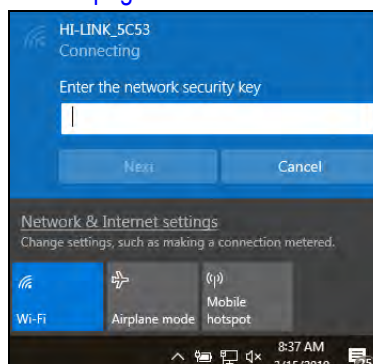

Figure 2-9. Default SSID

3.0 SCT-1000 Ethernet Module Parameters

3.1 Status and Configuration

Type the IP address into the address bar of a browser. The unit default is 192.168.16.205. Status & Configuration displays. The page is arranged into the following 5 menus

The screenshot shows the 'Status & Configuration' page. On the left is a navigation menu with 'Home' highlighted in a red box, and other options: 'General Settings', 'Port 0 (RS232) Settings', 'Port 1 (RS485) Settings', 'WiFi Settings', and 'Password Setting'. The main content area displays the following information:

- Name:** ETHD: Serial 2 Ethernet
- Firmware Revision:** 02.02.00.0064D
- IP Address:** 192.168.16.205
- MAC Address:** 00-1e-c0-ac-8b-48
- Serial Port 1 Option Switch:** 2-wire
- Operating Mode:** Serial Bridge

Below this is a table for 'Current port settings:'

	Port 0 (RS232)	Port 1 (RS485)
Baud Rate:	9600 bits/second	9600 bits/second
Data Size:	8 bits/character	8 bits/character
Parity:	None	None
Stop Bits:	1bit(s)	1bit(s)
Flow Control:	None	None
Physical I/F:	LAN	LAN
Protocol:	TCP	TCP
Local UDP Port Number:	3001	3002
Remote UDP Port Number:	3001	3002
UDP Trigger Char:	10 decimal ASCII	10 decimal ASCII
UDP Trigger Idle Timeout:	100 ms	100 ms
UDP Remote IP Address:	0.0.0.0	0.0.0.0
Local TCP Port Number:	23	26
TCP Timeout:	0 s	0 s
Modbus Mode:	RTU	RTU

Figure 3-1. Status & Configuration Page

General Settings	Change miscellaneous settings such as the ETHERNET/IP address	Section 3.2 on page 9
Port 0 (RS232) Settings	Setting TCP/UDP protocols for the conversion 232 and 485	Section 3.3 on page 11
Port 1 (RS485) Settings		
WiFi Settings	Change the WIFI IP address (if present)	Section 3.4 on page 14
Password Setting	Access Password	Figure 3.5 on page 14

Table 3-1. Status and Configuration Menus

3.2 General Settings

Click **General Settings** in the menu on the left side of the page to display the Miscellaneous Settings page. Here changes can be made to the IP Address Selection, General Configuration Settings or this device can be rebooted by selecting **Restore Factory Defaults**.

The top of the page displays the module's Name, Firmware Revision, IP Address and MAC Address. Click **Reboot** to reboot the module.

Miscellaneous Settings

Home

General Settings

Port 0 (RS232) Settings

Port 1 (RS485) Settings

Password Setting

Name: ETHD: Serial 2 Ethernet

Firmware Revision: 02.02.00.0064D

IP Address: 192.168.16.205

MAC Address: 00-1e-c0-ac-8b-48

Reboot

IP Address Selection

Address Type: Static IP

Static IP Address: 192 . 168 . 16 . 205

Subnet Mask: 255 . 255 . 255 . 0

Default Gateway: 0 . 0 . 0 . 0

Section 3.2.1

Save and Reboot

General Configuration Settings

Module Name: ETHD: Serial 2 Ethernet

UPnP port number: 6432

Web Server Port Number: 80

Operating Mode: Serial Bridge

Section 3.2.2

Save and Reboot

Restore Factory Defaults

Restore all options to their factory default.

Restore Defaults and Reboot

Section 3.2.3 on page 10

Figure 3-2. Miscellaneous Settings Page

3.2.1 IP Address Selection

This section provides a way to change the Address Type from the drop-down menu, as well as enter the Static IP Address, Subnet Mask, and Default Gateway. Click **Save and Reboot** to save changes and reboot the module.

3.2.2 General Configuration Settings

This section provides a way to change the Module Name, UPnP Port Number, Web Server Port Number, and Operating Mode. Click the drop-down to choose from the following Operating Modes. Click **Save and Reboot** to save changes and reboot the module.

- **Serial to Ethernet**
 - Translates the WLAN or LAN information into serial signals RS-232 or RS-485.
 - Sets both serial ports to 9600,n,8,1 with no flow control
 - Sets the TCP local ports to 23 and 26.
- **Serial Bridge**
 - Creates a bridge between the RS-232 and RS-485 signals.
 - Every packet received via WLAN or LAN is ignored by the module.
 - Sets both serial ports to 9600,n,8,1 with no flow control.
- **Port0: SNet Adapter - Port1: Serial to Ethernet**
 - Creates a network between two or more instruments.
 - Sets both serial ports to 115200,n,8,1 with no flow control,
 - Sets UDP local/remote ports to 3001 on Serial Port 0, and
 - Sets TCP local ports to 26 on Serial Port 1.



After clicking **Save and Reboot** and refreshing the screen, a **SETH-NET Service** option appears in the menu on the left side of the page. Click on it to monitor the current status of the connection as well as statistics.

SETH-NET Service Page

Home
General Settings
Port 0 (RS232) Settings
Port 1 (RS485) Settings
SETH-NET Service
Password Setting

Net Status

NetGroup ID	00
MyNode ID	00
Master Node ID	00
Nodes present	none

Net Statistics

	Packets received from...	Packets sent to...	Timeouts sending to...	Faults sending to...
Broadcast	n.a.	0	0	0
Node 1	0	0	0	0
Node 2	0	0	0	0
Node 3	0	0	0	0
Node 4	0	0	0	0
Node 5	0	0	0	0
Node 6	0	0	0	0
Node 7	0	0	0	0
Node 8	0	0	0	0

Serial Statistics

STX/ETX Mismatch	Rx Wrong packets (CRC)
0	0

Refresh Clear

Debug

Always Broadcast	No
Never Become Master	No

Submit

Figure 3-3. SETH-NET Service Page

• Modbus TCP

- Transmits Modbus data via LAN
- Sets both serial ports to 9600,n,8,2 with no flow control
- Sets Modbus-RTU on both serial ports, and sets TCP local ports to 502 and 503

Requires a network connection that uses TCP/IP protocols. In order to establish communication, connect a device that supports the Modbus RTU or Modbus ASCII on the module's RS-232/485 signals.

Click **Save and Reboot** to save changes and reboot the module.

3.2.3 Restore Factory Defaults

Restore all of the module options to their factory defaults. To do this, click **Restore Defaults and Reboot**.

3.3 Port Settings

Click on the **Port 0 (RS-232) Settings** or **Port 1 (RS-485) Settings** option in the menu on the left side of the page to display the current port settings. The Port Settings page displays the port's current Serial, LAN, UDP, and TCP settings in editable tables.

The first column of each table lists the parameters, the second shows the current setting of each parameter, and the third allows each parameter to be edited. If a parameter is changed, ensure that **Make these settings permanent** is checked, then click **Save** to save the changes.



To enable Wifi:

* Set WiFi settings in the WiFi menu function to **Enabled** See [Section 3.4 on page 14](#)

* Set Physical I/F to **WLAN**; See [Figure 3-4](#) or [Figure 3-5](#)

3.3.1 232-LAN/WLAN Configuration

The data transmitted via Ethernet or WIFI on port 23 (TCP) 3001 (UDP) will be redirected to the 232 serial port

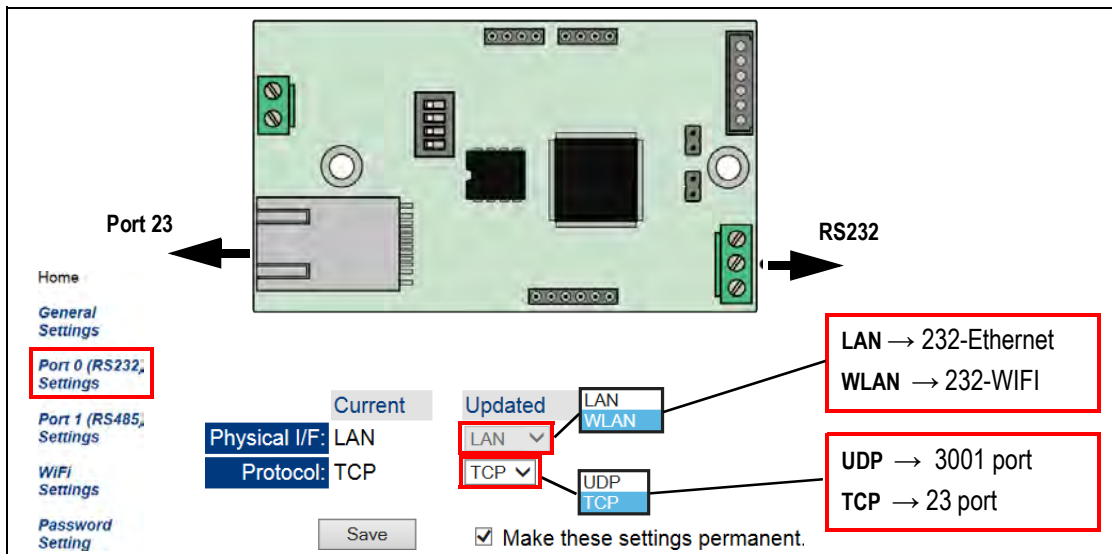

Figure 3-4. 232-LAN/WLAN Configuration

3.3.2 485-LAN/WLAN Configuration

The data transmitted via Ethernet or WIFI on port 26 (TCP) 3002 (UDP) will be redirected to the serial port 485.

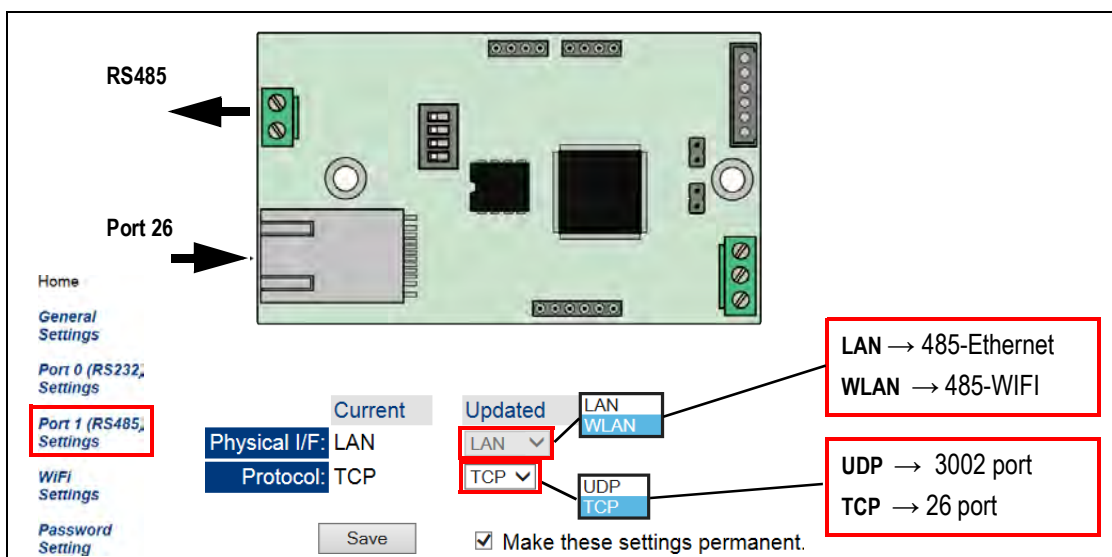

Figure 3-5. 485-LAN/WLAN Configuration

3.3.3 UDP Port Configuration

UDP communication parameters can be changed for both Port 0 and Port 1.

Set the Local UDP Port Number, Remote UDP Port Number, UDP Trigger Char, UDP Trigger Idle Timeout, and UDP Remote IP Address using the fields in the UDP table.

The screenshot shows a web interface for configuring UDP and TCP settings. On the left, there are navigation links: Home, General Settings, Port 0 (RS232) Settings, Port 1 (RS485) Settings, WiFi Settings, and Password Setting. The main content is divided into two sections: UDP and TCP. Each section has a 'Current' and an 'Updated' column. In the UDP section, the 'Updated' column for Local UDP Port Number, Remote UDP Port Number, and UDP Remote IP Address is highlighted with red boxes. The 'Make these settings permanent' checkbox is checked. The TCP section also has a 'Make these settings permanent' checkbox checked.

Figure 3-6. UDP Port Configuration

UDP Remote IP Address indicates the UDP destination of the IP data address

- If set to 0.0.0.0, the module sends data to the last IP connected
- If set to 255.255.255.255, the module sends broadcast data
- If set to xxx.xxx.xxx.xxx, the module sends data to the IP set



Note UDP settings are only editable if the Protocol parameter is set to UDP in the LAN Settings table.

3.3.4 Tunneling Mode

Tunneling mode allows the Ethernet protocol to overcome the limits of serial communication by creating a virtual connection. This mode requires the use of two modules and their respective UDP ports. This can only be performed in Serial to Ethernet mode.



Note Tunneling mode can only be set up between the same port on each module, i.e., Port0-Port0 or Port1-Port1.

To set up tunneling mode:

1. Navigate to each module's Port 0 or Port 1 Settings page.
2. Insert the Local UDP Port Number of module 1 into the Remote UDP Port Number field of module 2.
3. Insert the Local UDP Port Number of module 2 into the Remote UDP Port Number field of module 1.
4. Ensure the **Make these settings permanent** box is checked, then click **Save**.

Example:

	SCT-1000 Ethernet 1	SCT-1000 Ethernet 2
IP	192.168.16.205	192.168.16.206
Local UDP Port Number	3001	3002
Remote UDP Port Number	3002	3001
UDP Remote IP Address	192.168.16.206	192.168.16.205

Table 3-2. Example Tunneling Mode Parameters



Note Do not change the other UDP parameters.

To disable tunneling mode, set the UDP Remote IP Address field to 0.0.0.0 for both modules.

3.3.5 Double Tunneling Mode

Double tunneling mode functions the same as single tunneling mode, but can manage two virtual connections at the same time. This mode requires the use of two modules and their respective UDP ports. This can only be performed in Serial to Ethernet mode.



Note Double tunneling mode can only be set up between the same ports on each module, i.e., Port0-Port0 and Port1-Port1.

To set up double tunneling mode:

1. Navigate to each module's Port 0 Settings page.
2. Insert the Local UDP Port Number of module 1 into the Remote UDP Port Number field of module 2.
3. Insert the Local UDP Port Number of module 2 into the Remote UDP Port Number field of module 1.
4. Ensure the **Make these settings permanent** box is checked, then click **Save**.
5. Repeat steps 2-4 for each module's Port 1 settings.

Example:

	SCT-1000 Ethernet 1	SCT-1000 Ethernet 2
IP	192.168.16.205	192.168.16.206
Port 0		
Local UDP Port Number	3001	3002
Remote UDP Port Number	3002	3001
UDP Remote IP Address	192.168.16.206	192.168.16.205
Port 1		
Local UDP Port Number	3003	3004
Remote UDP Port Number	3004	3003
UDP Remote IP Address	192.168.16.206	198.168.16.205

Table 3-3. Example Port Settings



Note Do not change the other UDP Parameters.

3.3.6 Broadcast Mode

Setting a module to broadcast mode designates it as a Master module, and allows it to send data to other modules set on the same UDP port. To set up broadcast mode, enter **255.255.255.255** in the module's UDP Remote IP Address field. Ensure the **Make these settings permanent** box is checked, then click **Save**.

3.3.7 TCP Port Configuration

TCP communication parameters can be changed for both Port 0 and Port 1.

Set the Local TCP Port Number, TCP Timeout, and Modbus Mode using the fields and drop-down in the TCP table.

Figure 3-7. TCP Port Configuration



Note TCP settings are only editable if the Protocol parameter is set to TCP in the LAN Settings table

3.3.8 Serial Port Configuration

Set the Baud Rate, Data Size, Parity, Stop Bits, and Flow Control using the drop-downs in the Serial Settings table.

Serial Settings	Current	Updated
Baud Rate:	9600 bits/second	9600 bits/S
Data Size:	8 bits/character	8 bits/character
Parity:	None	None
Stop Bits:	1 bit(s)	1 bit(s)
Flow Control:	None	None

Save Make these settings permanent.

Figure 3-8. Serial Settings

3.4 WiFi (Optional)

If the optional Wifi card is installed WiFi Settings will be visible in the menu.

Network Settings **Enabled**

WiFi Function: Disabled

SSID: DiniNet

Network Mode: Infrastructure

Ad Hoc Mode: Joiner

Security Settings

Security Type: Open

Security Key:

IP Settings

Address Type: DHCP/AutoIP / Static IP

Static IP Address: 192 . 168 . 16 . 207

Subnet Mask: 255 . 255 . 255 . 0

Select the encryption type and enter the password

Open

WPA/PSK
WPA2/AES
WEP

Figure 3-9. TCP Port Configuration



Note The SSID distinguishes between uppercase and lowercase letters

3.5 Password Setting

A password can be set to prevent unwanted access to the module's settings. To set a password:

1. Click **Password Setting** in the menu on the left side of the page.
2. Enter a password into the **Password** field, then type the same password again into the **Re-enter** field.
3. Click **Submit!** to save the password.

Home

General Settings

Port 0 (RS232, Settings)

Port 1 (RS485, Settings)

WiFi Settings

Password Setting

Password:

Re-enter:

Submit!

Figure 3-10. Setting a Password



Note To disable the Password feature, remove all text in both password fields and click **Submit!**



If password is enabled, a prompt will appear before the configuration home page opens. Enter the correct password and click **Enter** to access the configuration home page.

3.6 Manually Changing the Functioning Mode

The module has four functioning modes than can be selected by changing the dip-switches located on the CPU board. See [Section 2.2 on page 5](#).

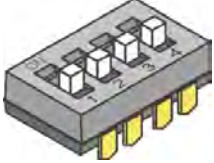

Every time the functioning mode is changed, the module is reset to default parameters and IP address of 192.168.16.205.

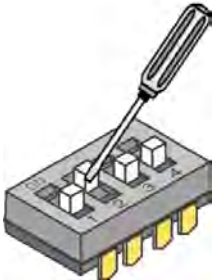
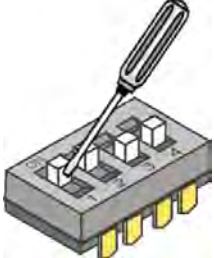
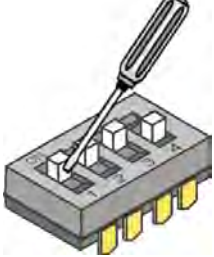
 <p>ON OFF 1-2-3-4</p>	<p>Converting Serial Ethernet or WiFi Convert an ETHERNET or WIFI signal to 232/485</p> <table border="1" data-bbox="808 485 1273 625"> <thead> <tr> <th></th> <th>232</th> <th>485</th> </tr> </thead> <tbody> <tr> <td>TCP</td> <td>Port 23</td> <td>Port 26</td> </tr> <tr> <td>UDP</td> <td>Port 3001</td> <td>Port 3002</td> </tr> </tbody> </table> <p>Sets serial to 9600 n-8-1</p>		232	485	TCP	Port 23	Port 26	UDP	Port 3001	Port 3002
	232	485								
TCP	Port 23	Port 26								
UDP	Port 3001	Port 3002								
 <p>ON 1 Off 2-3-4</p>	<p>Network Between instruments Connects multiple indicators to each other, sharing archives and remote scale (only for AF03) 485 serial port is set to Ethernet</p> <table border="1" data-bbox="808 821 1273 915"> <thead> <tr> <th></th> <th>TCP</th> <th>UDP</th> </tr> </thead> <tbody> <tr> <td>485</td> <td>Port 26</td> <td>Port 3002</td> </tr> </tbody> </table> <p>Sets serial to 115 n-8-1</p>		TCP	UDP	485	Port 26	Port 3002			
	TCP	UDP								
485	Port 26	Port 3002								
 <p>ON 2 OFF 1-3-4</p>	<p>Modbus TCP Converts Modbus to Modbus TCP ports between Ethernet/WIFI and 232/485</p> <table border="1" data-bbox="808 1073 1273 1167"> <thead> <tr> <th></th> <th>232</th> <th>485</th> </tr> </thead> <tbody> <tr> <td>TCP</td> <td>Port 502</td> <td>Port 503</td> </tr> </tbody> </table> <p>Sets serial to 6600 n-8-2</p>		232	485	TCP	Port 502	Port 503			
	232	485								
TCP	Port 502	Port 503								
 <p>ON 1-2 OFF 3-4</p>	<p>232-485 Conversion Transforms 232 signal to 485 and vice versa ETHERNET/WIFI disabled</p> <p>Sets serial to 9600 n-8-1</p>									
 <p>ON 1-2-3 OFF 4</p>	<p>Configuration From Browser Enables configuration to be made from browser in Operating Mode of General Settings</p>									

3.7 Resetting the SCT-1000 Ethernet

The module can be reset to defaults in any one of three ways:

3.7.1 Close the DFLT jumper

The SCT-1000 Ethernet can be reset and return it to its initial settings at any time. To reset the SCT-1000 Ethernet:

1. Switch off the device.
2. Open the device to access the jumper DFLT.
3. Close the DFLT jumper.
4. Switch on the device. The red and green LEDs blink repeatedly.
5. Complete the reset by opening the jumper and restarting the module.

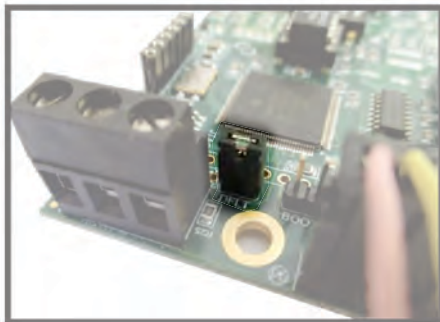

Close DFLT jumper

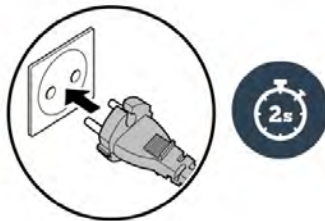

Turn on module and wait 2 sec

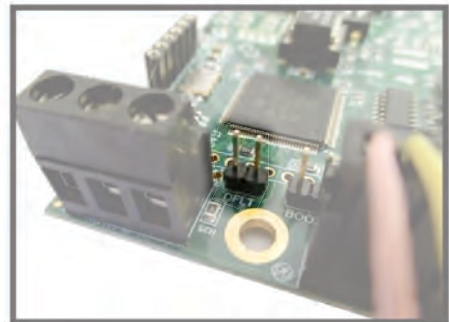

Remove jumper when the two LEDs flash.

Figure 3-11. Close the DFLT Jumper

3.7.2 Manually change functioning mode

Module resets with every change of the functioning mode. See [Figure 3-12](#).

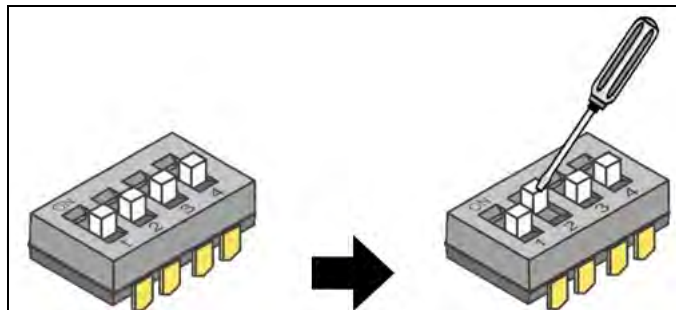

Figure 3-12. Change Functioning Mode

3.7.3 Restore factory defaults from web browser

In the **General Settings** Menu, click on **Restore Defaults and Reboot**. See [Section 3.2.3 on page 10](#).

4.0 SCT-2200 Wi-Fi Module Parameters

4.1 Status and Configuration

Type the IP address into an internet browser. The default address is 192.168.16.254.

- The SCT-2200 Wi-Fi will require a password. See [Figure 4-1](#). Enter default device Username: admin and Password: admin. To change device password see [Section 4.4.1 on page 23](#).

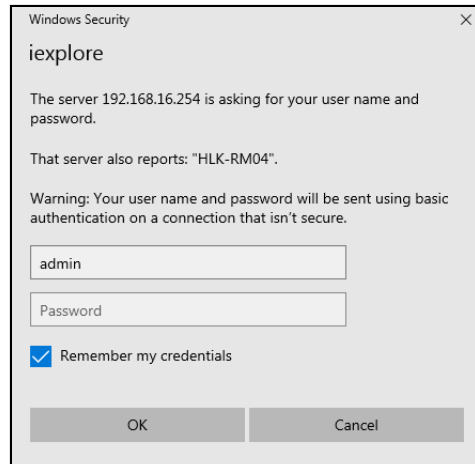

Figure 4-1. Enter Device Password

Click on the **Serial2Net Settings** option in the menu on the left side of the page to display the Serial2Net Settings page. Here changes can be made to the NetMode and serial communications settings.

To adopt changes to NetMode and serial communication settings, change desired configurations and click **Apply**. The unit will restart with the new configuration settings applied. NetMode and serial communication settings are explained in [Section 4.2 on page 18](#) and [Section 4.3 on page 21](#).



Figure 4-2. Serial2Net Settings

4.2 NetMode

The module can be configured into four modes within the NetMode menu of the Serial2Net Settings. Click on the NetMode dropdown and the following options will display.

- Default
- ETH-SERIAL - Serial to Ethernet
- Wi-Fi(CLIENT)-SERIAL - Serial to Wi-Fi CLIENT
- Wi-Fi(AP)-SERIAL - Serial to Wi-Fi AP (access point)

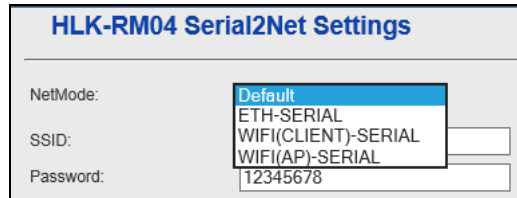

Figure 4-3. NetMode Menu

4.2.1 Default Mode

- Wi-Fi is enabled in AP mode
- ETH1 is enabled as WAN
- ETH2 is enabled as LAN
- Two-way data communication is possible between COM1 and the network
- All Wi-Fi encryption methods are supported
- Wi-Fi device can connect with the module and become the device under Wi-Fi LAN
- WAN default IP is dynamic
- LAN and Wi-Fi are enabled by the default DHCP server

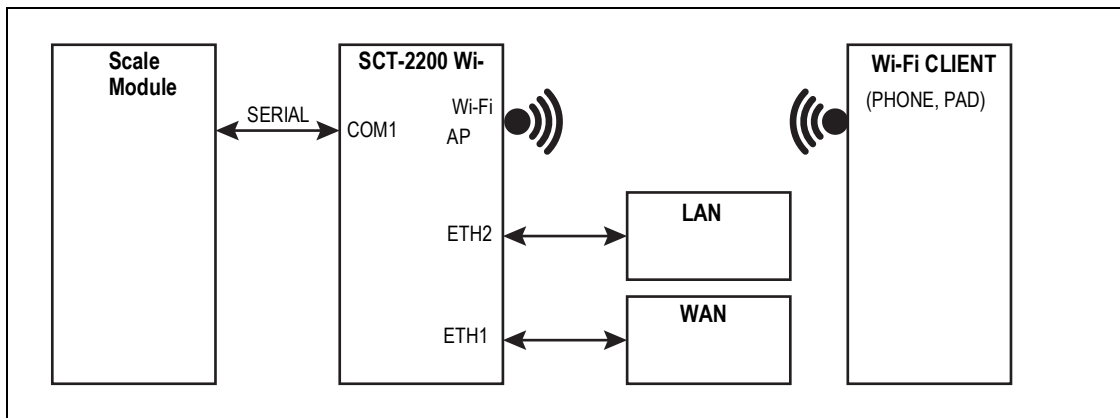

Figure 4-4. Default Mode Model

4.2.2 Serial to Ethernet

- ETH1 is enabled
- Wi-Fi and ETH2 are disabled
- Two-way data communication is possible between COM1 and the network
- Ethernet can be configured as a dynamic IP address (DHCP) or as a static IP address (STATIC)

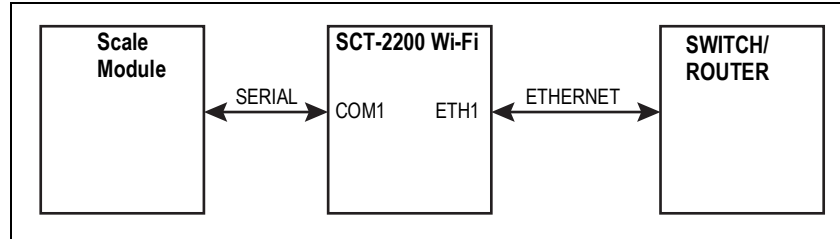

Figure 4-5. Serial to Ethernet Model

NetMode:	<input type="text" value="ETH-SERIAL"/>
IP Type:	<input type="text" value="DHCP"/>

Figure 4-6. Serial to Ethernet-Dynamic IP

NetMode:	<input type="text" value="ETH-SERIAL"/>
IP Type:	<input type="text" value="STATIC"/>
IP Address:	<input type="text" value="192.168.11.254"/>
Subnet Mask:	<input type="text" value="255.255.255.0"/>
Default Gateway:	<input type="text" value="192.168.11.1"/>
Primary DNS Server:	<input type="text" value="192.168.11.1"/>
Secondary DNS Server:	<input type="text" value="8.8.8.8"/>

Figure 4-7. Serial to Ethernet-Static IP

4.2.3 Serial to Wi-Fi CLIENT

- Wi-Fi is enabled in client mode
- ETH1 and ETH2 are disabled
- Two-way data communication is possible between COM1 and the network
- Wi-Fi(CLIENT) can be configured as a dynamic IP address (DHCP) or as a static IP address (STATIC)
- All Wi-Fi encryption methods are supported

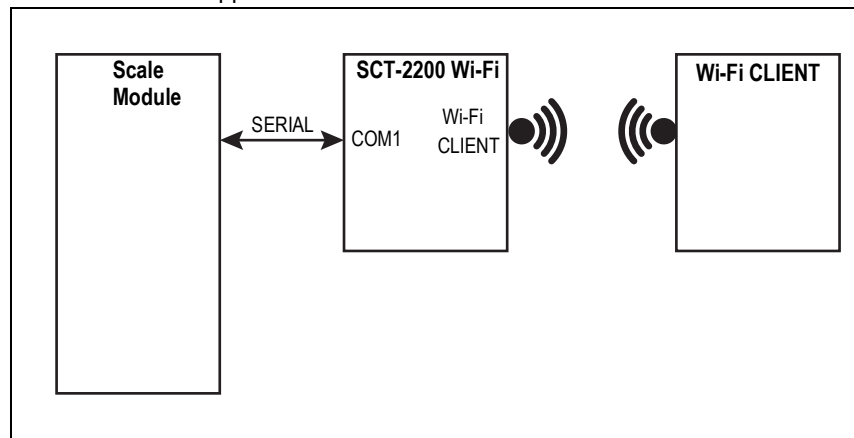

Figure 4-8. Wi-Fi(CLIENT)-Serial Mode Model

NetMode:	<input type="text" value="WIFI(CLIENT)-SERIAL"/>
SSID:	<input type="text" value="HI-LINK_5C53"/> <input type="button" value="Scan"/>
Encrypt Type:	<input type="text" value="WPA2 AES"/>
Password:	<input type="text" value="12345678"/>
IP Type:	<input type="text" value="DHCP"/>

Figure 4-9. Serial to Wi-Fi CLIENT Dynamic IP

NetMode:	<input type="text" value="WIFI(CLIENT)-SERIAL"/>
SSID:	<input type="text" value="HI-LINK_5C53"/> <input type="button" value="Scan"/>
Encrypt Type:	<input type="text" value="WPA2 AES"/>
Password:	<input type="text" value="12345678"/>
IP Type:	<input type="text" value="STATIC"/>
IP Address:	<input type="text" value="192.168.11.254"/>
Subnet Mask:	<input type="text" value="255.255.255.0"/>
Default Gateway:	<input type="text" value="192.168.11.1"/>
Primary DNS Server:	<input type="text" value="192.168.11.1"/>
Secondary DNS Server:	<input type="text" value="8.8.8.8"/>

Figure 4-10. Serial to Wi-Fi CLIENT Static IP

4.2.4 Serial to Wi-Fi AP

- Wi-Fi is enabled in AP mode
- ETH1 and ETH2 are disabled
- Two-way data communication is possible between COM1 and the network
- All Wi-Fi encryption methods are supported
- Wi-Fi device can connect with the module and become the device under Wi-Fi LAN

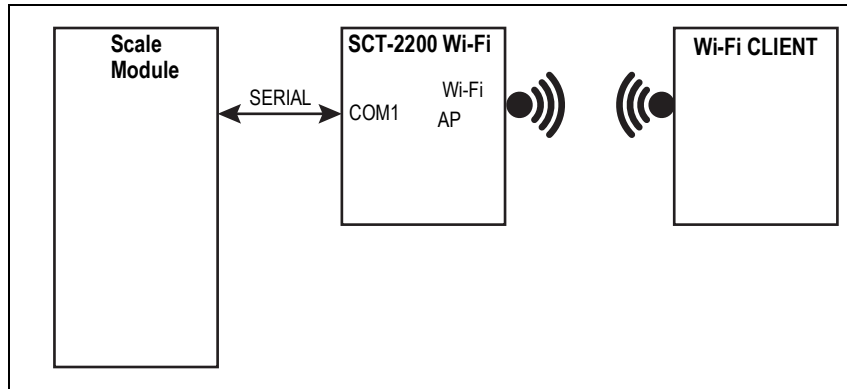

Figure 4-11. Serial to Wi-Fi AP Mode Model

NetMode:	<input type="text" value="WIFI(AP)-SERIAL"/>
SSID:	<input type="text" value="HI-LINK_5C53"/>
Encrypt Type:	<input type="text" value="WPA2 AES"/>
Password:	<input type="text" value="12345678"/>
IP Address:	<input type="text" value="192.168.11.254"/>
Subnet Mask:	<input type="text" value="255.255.255.0"/>

Figure 4-12. Serial to Wi-Fi AP

4.3 Serial Settings

The Serial Settings menu allows for the parameters of the serial communications to be changed. There are 3 columns of information in this menu.

1. The first column lists the name of the parameter to be adjusted.
2. The second column, labeled Current, shows the current serial communication configuration.
3. The third column, labeled Updated, shows cells that can be altered to revise the current parameters.

To adopt new parameters, adjust the applicable cells and click **Apply**.

	Current	Updated
Serial Configure:	115200,8,n,1	<input type="text" value="115200,8,n,1"/>
Serial Framing Length:	64	<input type="text" value="64"/>
Serial Framing Timeout:	10 milliseconds	<input type="text" value="10"/> milliseconds (< 256, 0 for no timeout)
Network Mode:	server	<input type="button" value="Server"/>
Remote Server Domain/IP:	192.168.11.245	<input type="text" value="192.168.11.245"/>
Locale/Remote Port Number:	8080	<input type="text" value="8080"/>
Network Protocol:	tcp	<input type="button" value="TCP"/>
Network Timeout:	0 seconds	<input type="text" value="0"/> seconds (< 256, 0 for no timeout)
		<input type="button" value="Apply"/> <input type="button" value="Cancel"/>

Figure 4-13. Serial Settings Menu

Parameter	Description
Serial Configure	Serial configuration format is the following parameters separated by commas: <ul style="list-style-type: none"> • Baud rate, data bits, parity bit, stop bit Example: "115200, 8,n,1"
Serial Framing Length	The length of the serial framing
Serial Framing Timeout	The time of serial framing
Network Mode	Choose: Client, Server or None
Remote Server Domain/IP	Remote Server Domain/IP address Example: 192.168.11.245 or www.ricelake.com
Locale/Remote Port Number	The specified parameter is not the same under different network modes; client specifies the port number on the remote, server specified local port number
Network Protocol	Choose: TCP or UDP
Network Timeout	Under the server network mode, no data transmission within the timeout period, the connection will be disconnected; 0 specifies never disconnected

Table 4-1. Serial Settings Definitions

There are four modes for serial-net conversion. The modes can be activated by adjusting the **Network Mode** and the **Network Protocol** in the menus above. Those modes are:

- TCP Server
- TCP Client
- UDP Server
- UDP Client

4.3.1 TCP Server

In this mode, the module is listening on the specified port, waiting for the TCP Client connection. If connected, all TCP data is sent directly to the serial port endpoint and the data of the serial endpoint is sent to the TCP Client.

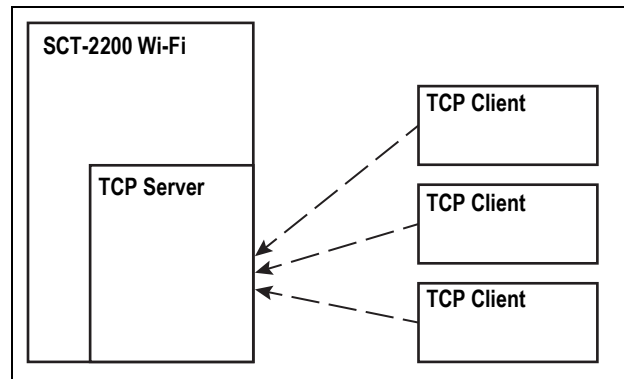

Figure 4-14. TCP Server Model

4.3.2 TCP Client

In this mode, the module is connected to the specified domain/IP port. All the data sent from the TCP Server-side endpoints will be sent directly to the serial port, the data from the serial endpoints sent to the TCP Server-side. Abnormal network disconnect will cause the module active reconnect. TCP Active reconnection function enable, TCP Server initiative disconnected, the module will immediately take the initiative to reconnect, and otherwise the module will not reconnect.

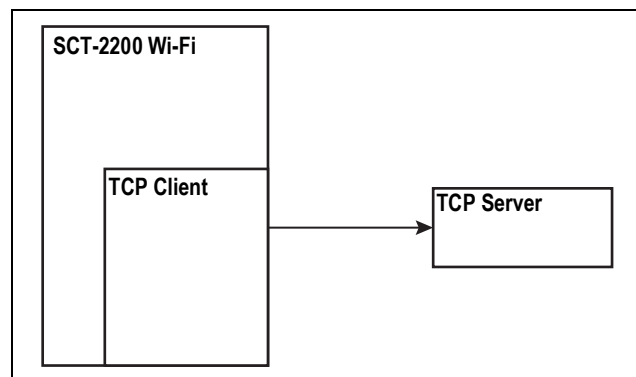

Figure 4-15. TCP Client Model

4.3.3 UDP Server

In this mode, the module opens the local designated port. The module will send the data to the serial port, and record the remote ip, port. The module will record only the last information on the remote connection. Serial received data will be sent directly to the recorded remote ip, port.

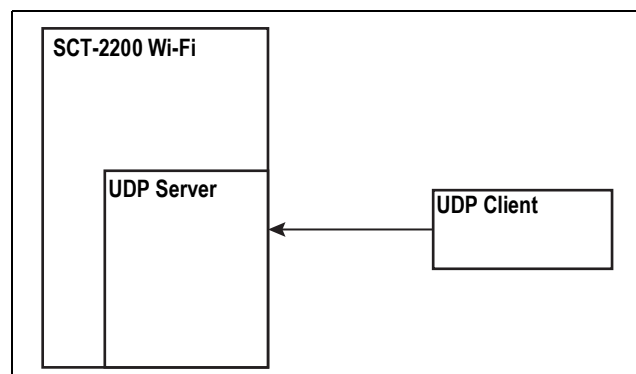

Figure 4-16. UDP Server Model

4.3.4 UDP Client

In this mode, the module directly sends the serial data to the specified ip port. The serial data returned from the server-side will be distributed to the serial port.

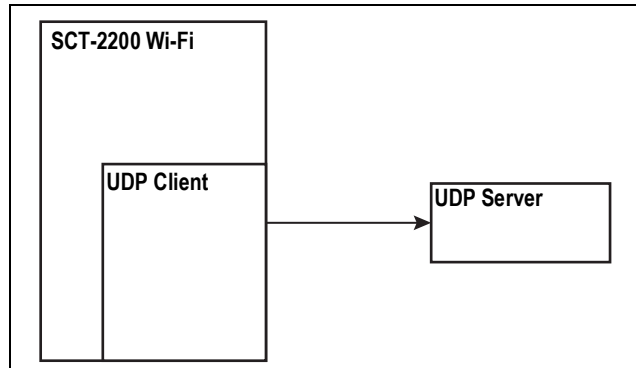

Figure 4-17. UDP Client Model

4.4 Administration

4.4.1 System Management

The System Management tab allows for the Administrator account and password to be changed.

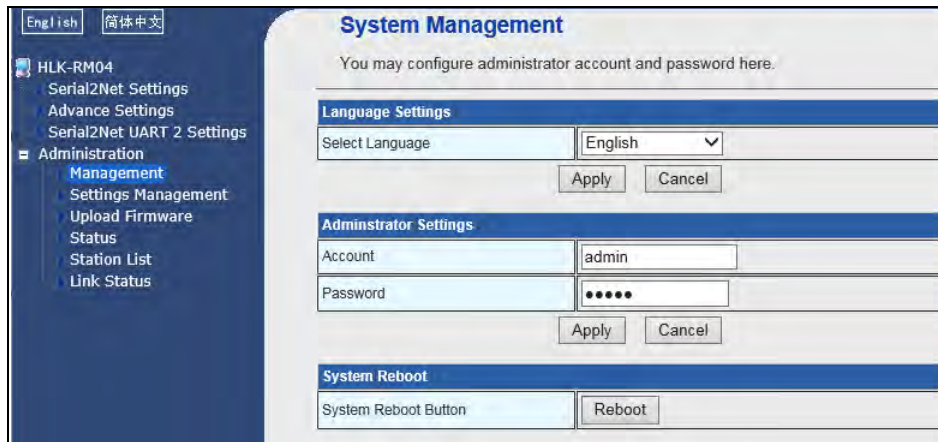

Figure 4-18. System Management

4.4.2 Settings Management

The Settings Management menu enables exporting and importing of Settings.

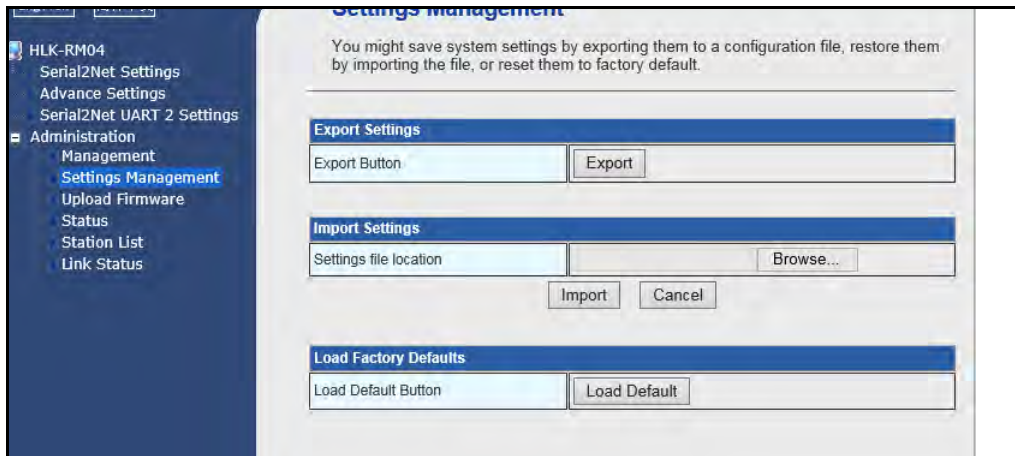

Figure 4-19. Setting Management

Export Settings

To save the current setting of the SCT-2200 Wi-Fi click **Export** in the Settings Management menu. See Figure 4-19. The module will create a DAT file of the settings. Follow the browser prompts to save the file in a folder on the computer.

Import Settings

To import settings that have been saved to the computer.

1. Click **Browse...** in the import settings menu. See Figure 4-19.
2. Follow the prompts to find the location of the DAT file. See Figure 4-20.
3. Click **Open**. See Figure 4-20. The file name will populate the box. See Figure 4-21.

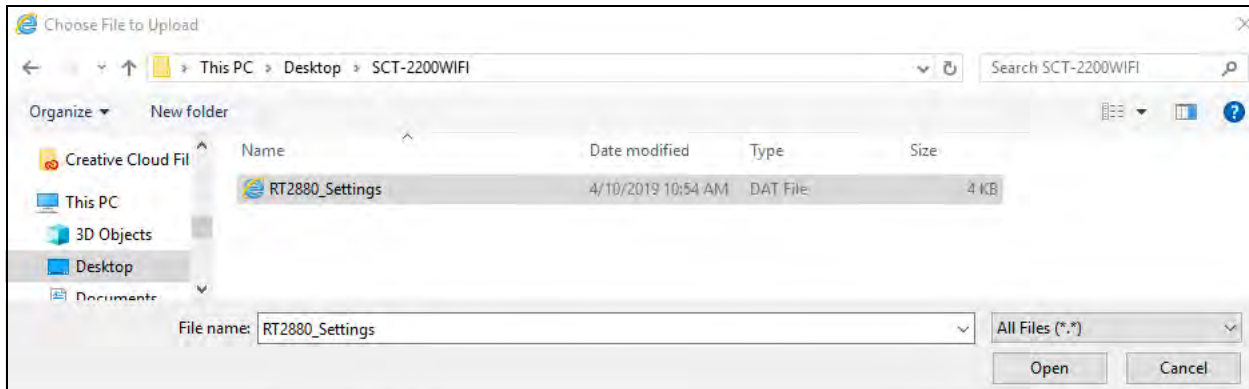

Figure 4-20. Find the File Location

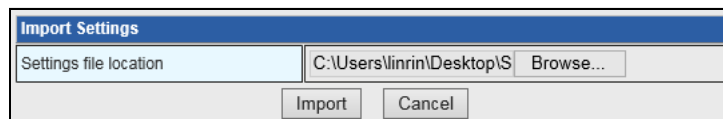

Figure 4-21. File name

4. Click **Import**. The unit will restart with the imported settings enabled.

Load Factory Defaults

To restore factory default settings to the SCT-2200 Wi-Fi, click **Load Default**. Upon system reboot, the system will be returned to factory settings.

5.0 Specifications

5.1 Ethernet Option Card and SCT-1000 Ethernet Specifications

Physical Characteristics

Power Supply	+5Vdc / +12Vdc (AMP) +12Vdc +24Vdc (WIRE TERMINAL)
Max Consumption	200mA, 5W at 24Vdc
Dimensions	2" x 2.5" x 3.5" (53mm x 58mm x 90mm)
Case	ABS case for panel mounting on Omega/DIN bar
Operating Temperature	14°F +122°F (-10°C +50°C)
Operating humidity	10% - 90%RH (noncondensing)
Storage Temperature	-40 - 176°F (-40-80°C)
Storage humidity	5%-90% RH (noncondensing)
Connections	RS-232 RS-485 RJ45 bidirectional port

Network Parameters

Network Management	Remote Web Management Configuration file import and export WEB software upgrade
Protocols	TCP, UDP, DHCP, SNMP, SSL 3.0/TLS 1.0, HTTP, SMTP, ICMP, IGMP
Available Conversions	RS-232 ↔ Ethernet RS-485 ↔ Ethernet RS-232 ↔ RS-485 MODBUS TCP ↔ Ethernet
Network Standards	10/100 Base-T IEEE802.3, IEEE802.3u
LAN Data Transfer Rate	10-100Mbps
Serial Baud Rate	50-230400bps

5.2 SCT-2200 Wi-Fi Specifications

Physical Characteristics

Power Supply	+5Vdc / +12Vdc (AMP) +12Vdc +24Vdc (WIRE TERMINAL)
Max Consumption	200mA, 5W at 24Vdc
Dimensions	.98" x 4.52" x 4.72" (25mm x 115mm x 120mm)
Case	ABS case for panel mounting on Omega/DIN bar
Operating temperature	-4 - 158°F (-20-70°C)
Operating humidity	10% - 90%RH (noncondensing)
Storage Temperature	-40 - 176°F (-40-80°C)
Storage humidity	5%-90% RH (noncondensing)
Connections	2 RS-485 bidirectional ports 1 RS-232 bidirectional port 1 LAN port 1 WAN port On-board Antenna/External Antenna

Network Parameters

Network Management	Remote Web Management Configuration file import and export WEB software upgrade
Protocols	TCP, UDP, DHCP, SNMP, SSL 3.0/TLS 1.0, HTTP, SMTP, ICMP, IGMP
TCP Connection	Max Connections: 20
UDP Connection	Max Connections: 20
Available Conversions	RS-485 ↔ Ethernet RS-485 ↔ Wi-Fi

Ethernet Network Parameters

Ethernet Standard	10/100base-T IEEE802.3, IEEE802.3u
LAN Data Transfer Rate	10-100Mbps
Serial Baud Rate	50-230400bps

Wi-Fi Network Parameters

Network Standards	IEEE 802.11n, IEEE 802.11g, IEEE 802.11b
Wireless Transmission Rate	11n: max 150Mbps 11g: max 54Mbps 11b: max 11Mbps
Wi-Fi Channels	1-14
Wireless Frequency	2.4-2.4835G
Signal Strength	12-15DBM
Antenna Type	On-board Antenna/External Antenna
Wi-Fi Work Mode	Client/AP/Router
WDS Function	Support WDS wireless bridge connection
Wireless Security	Wireless MAC address filtering Wireless security function switch 64/128/152 bit WEP encryption WPA-PSK/WPA2-PSK, WPA/SPA2 security mechanism

Compliance



The SCT 22000 complies with Part 15 of the FCC Rules. Operation is subject to the following conditions:

- This device may not cause harmful interference.
- This device must accept any interference received, including interference that may cause undesired operation.

Radio certificate number:

WiFi: US: ZXVHLK-RM04

6.0 Compliance

	EU DECLARATION OF CONFORMITY <i>EU-KONFORMITÄTSERKLÄRUNG</i> <i>DÉCLARATION UE DE CONFORMITÉ</i>		Rice Lake Weighing Systems 230 West Coleman Street Rice Lake, Wisconsin 54868 United States of America 
	Type/Typ/Type: SCT indicator series		
English	We declare under our sole responsibility that the products to which this declaration refers to, is in conformity with the following standard(s) or other regulations document(s).		
Deutsch	Wir erklären unter unserer alleinigen Verantwortung, dass die Produkte auf die sich diese Erklärung bezieht, den folgenden Normen und Regulierungsbestimmungen entsprechen.		
Francais	Nous déclarons sous notre responsabilité que les produits auxquels se rapporte la présente déclaration, sont conformes à la/aux norme/s suivante ou au/aux document/s normatif/s suivant/s.		
EU Directive	Certificates	Standards Used / Notified Body Involvement	
2014/30/EU EMC	-	EN 61000-6-2:2015, EN 61000-6-4:2007+A1:2011, EN61326-1:2013, EN55011:2009 +A1:2010	
2014/35/EU LVD	-	EN 61010-1:2010	
2011/65/EU RoHS	-	EN 50581:2012	
Signature:			Place: <u>Rice Lake, WI USA</u>
Type Name:	<u>Richard Shipman</u>		Date: <u>May 3, 2019</u>
Title:	<u>Quality Manager</u>		



© Rice Lake Weighing Systems Europe B.V. Specifications subject to change without notice.
Rice Lake Weighing Systems is an ISO 9001 registered company.

NL-6666 MH Heteran • Netherlands
TEL: +31 (0)26 472 1319 • FAX: +31 (0)88 234 9100