

# SCT-100

*Digital Weight Transmitter/Indicator*

## Technical Manual



An ISO 9001 registered company  
© Rice Lake Weighing Systems. All rights reserved.

Rice Lake Weighing Systems® is a registered trademark of  
Rice Lake Weighing Systems.  
All other brand or product names within this publication are trademarks or  
registered trademarks of their respective companies.

All information contained within this publication is, to the best of our knowledge, complete and accurate at the time of publication. Rice Lake Weighing Systems reserves the right to make changes to the technology, features, specifications and design of the equipment without notice.

The most current version of this publication, software, firmware and all other product updates can be found on our website:

[www.ricelake.com](http://www.ricelake.com)

# INDEX

<b>1. REQUIREMENTS FOR AN OPTIMAL INSTALLATION</b> .....	<b>2</b>
1.1 ELECTRICAL PRECAUTIONARY MEASURES.....	3
1.1.1 CABLE CLASSIFICATION.....	3
1.1.2 RECOMMENDED DISTANCES AMONG CABLES.....	4
1.1.3 MAXIMUM CABLE LENGTH.....	4
1.2 EARTHING SYSTEM.....	5
<b>2. MAIN TECHNICAL SPECIFICATIONS</b> .....	<b>7</b>
<b>3. CONNECTION TO THE LOAD RECEIVER</b> .....	<b>8</b>
<b>4. SETUP ENVIRONMENT</b> .....	<b>9</b>
4.1 SET-UP ENVIRONMENT BLOCK DIAGRAM.....	10
4.2 DESCRIPTION OF THE STEPS.....	13
<b>5. CALIBRATION</b> .....	<b>29</b>
5.1 Calibration procedure for the INDEPENDENT CHANNELS and "TRANSM" modes.....	29
5.2 Calibration procedure for DEPENDENT CHANNELS MODE (could eventually be digitally equalized).....	31
5.3 IN CASE THE ZONE OF USE IS DIFFERENT FROM THE CALIBRATION ZONE ONE SHOULD:.....	33
5.4 QUICK CALIBRATION OF ZERO.....	33
5.5 THEORETICAL CALIBRATION.....	33
5.6 MANUAL CALIBRATION OF A DEFINED WEIGHT.....	34
<b>6. DISPLAY OF THE GRAVITY ACCELERATION AND CORRECTION OF THE WEIGHING ERROR due to the different gravity acceleration between the calibration and the utilization zone.</b> .....	<b>34</b>
<b>7. SERIAL OUTPUTS</b> .....	<b>35</b>
7.1 RS485 (SCT-100 / SCT-100AN) SERIAL PORT.....	35
7.2 RS232 or COM2 SERIAL PORT.....	38
7.3 PROFIBUS PORT (SCT-100PB).....	39
7.4 SERIAL PORT TRANSMISSION MODES.....	39
7.4.1 PC PORT SELECTION.....	39
7.4.2 PC PORT.....	40
7.4.3 PRN PORT.....	42
7.5 SERIAL COMMANDS FORMAT.....	43
7.6 TRANSMISSION PROTOCOLS.....	52
7.6.1 STANDARD STRING.....	52
7.6.2 EXTENDED STRING.....	53
7.6.3 MULTISCALE STRING.....	54
7.6.4 MASTER MODE STRINGS.....	55
<b>8. REMOTE SCALE CONFIGURATION</b> .....	<b>56</b>
<b>9. MASTER/SLAVE AND REPEATER MODES CONFIGURATIONS</b> .....	<b>57</b>
9.1 REPEATERS.....	57
9.1.1 $rEPE.dC$ .....	57
9.1.2 $rEPE.B$ .....	57
9.1.3 $rEPE.ln$ .....	58
9.1.4 $!!rEPE$ .....	59
9.2 MASTER/SLAVE.....	60
<b>10. ANALOGUE OUTPUT (OPTIONAL, AVAILABLE DEPENDING ON THE MODEL)</b> .....	<b>61</b>
<b>11. PROGRAMMING THE PRINTOUTS</b> .....	<b>63</b>
11.1 SAVING THE LABEL IN THE LABELLER'S PERMANENT MEMORY.....	73
<b>12. PRINTING THE HEADING</b> .....	<b>73</b>
<b>13. ERROR MESSAGES</b> .....	<b>74</b>
<b>14. CONNECTION SCHEMES</b> .....	<b>75</b>
14.1 SCT-100 / SCT-100AN MOTHERBOARD.....	75
14.2 SCT-100PB MOTHERBOARD.....	78
14.3 RS 485 SERIAL PORT.....	81

**NOTE FOR THE TECHNICIAN:**

Please take note that when the (USER MAN.REF.) is mentioned, this refers to the user manual.

**!!WARNING!!**

For the **ATEX** weight indicator version it is **COMPULSORY** to read and understand the **ATEX ATTACHMENT** in the end of the user manual (USER MAN.REF.) containing important warnings.



**1. REQUIREMENTS FOR AN OPTIMAL INSTALLATION**



To obtain the best results it is recommended to install the indicator and the platform (or transducer) in a place with the following conditions:

**A flat, level surface on which to rest**

**Stable and vibration free**

**No dust or strong vapours**

**No draughts**

**Make sure the platform is level or that the loading cells are resting evenly**

**Moderate temperature and humidity (15 - 30°C and 40-70%)**

**Do not install anywhere where there is the risk of explosion**

**All the indicator connections have to be made respecting the rules applicable in the zone and in the installing environment. Respect the recommended electrical precautionary measures described in section 1.1.**

**Make sure that the grounding is made correctly, see section 1.2.**

**Everything not expressly described in this manual has to be considered as improper use of the equipment.**

**Avoid welding with load cells installed.**

**Use waterproof sheaths and couplings in order to protect the load cell cables.**

**Use a waterproof junction box to connect the cells.**

## 1.1 ELECTRICAL PRECAUTIONARY MEASURES

Mains power supply is restricted to within  $\pm 10\%$  of the rated voltage

Electric protections (fuses etc.) are provided by the technician installing the instrument.

Respect the recommended minimal distances that are mentioned for the various cable categories, see sections 1.1.1 and 1.1.2.

The extension leads of the load cells or signal amplifiers, used for the connection of the serial ports and analogue output must be within the allowed maximum lengths, see section 1.1.3.

The extension leads of the load cells or signal amplifiers must be screened. In addition they must be laid on their own in a raceway or metal pipe as far away as possible from the power supply cables.

Install "RC" filters on the contactor coils, on the solenoid valves and on all devices producing electric disturbances.

If it is possible that condensation could form inside the weight transmitter it is advisable to leave the instrument powered at all times.

Every shielded cable or not (for instance PC cable, cell cable, power supply cable) connected to the indicator should be as shorter as possible, then you have to come out of the shield the minimum length of cable, then connect to the terminal box;

If the indicator is situated inside an electric panel, the power supply cable should be a shielded cable as shorter as possible, distant from every coil supply cable, inverter, electromotive force, etc. and in addition dedicate an uncoupler transformer in order to feed the indicator only.

### 1.1.1 CABLE CLASSIFICATION

The various cables are classified depending on the transmitted signals:

#### Category I

- Field bus, LAN (PROFIBUS, Ethernet, Devicenet...)
- Shielded data cables (RS232 ...)
- Shielded cables for analogue/digital signals < 25V (sensors, load cells...)
- Low tension power supply cables (< 60V)
- Coaxial cables

#### Category II

- DC supply cables with tension > 60V and < 400V
- AC supply cables with tension > 25V and < 400V

#### Category III

- Power supply cables with tension > 400V
- Telephone cables

#### Category IV

- Any cable subject to lightning

### 1.1.2 RECOMMENDED DISTANCES AMONG CABLES

- When the cables are laid next to each other, these must be at the distances in the table below
- These distances are valid if in the air; these are reduced if the raceways are separated by grounded metallic shields.
- Different category cables can cross each other (90°)

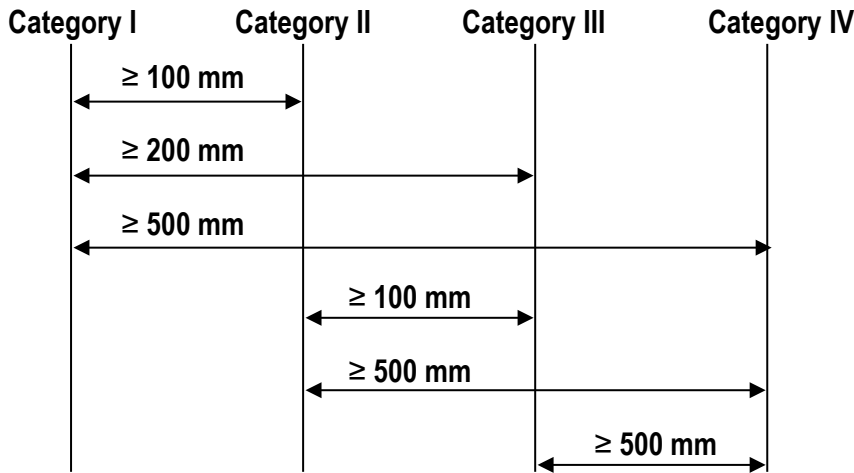

### 1.1.3 MAXIMUM CABLE LENGTH

#### LOAD CELL CABLE

The maximum reachable length from the line using the appropriate load cell cable is:

- 50 m with cable 6 x 0,25 mm<sup>2</sup>
- 100 m with cable 6 x 0,5 mm<sup>2</sup>

#### RS232 CABLE

The maximum reachable length from the line using the RS232 cable with a maximum baud rate of 19200, is about 15 m.

#### RS485 CABLE

The maximum reachable length from the line with the use of the appropriate cable for RS 485 connections (see section 7.1), is about 1200 meters.

#### ANALOG OUTPUT CABLE

The maximum length of the analogue output cable in current is:

- 100 m with cable 2 x 0,25 mm<sup>2</sup>
- 150 m with cable 2 x 0,5 mm<sup>2</sup>
- 300 m with cable 2 x 1 mm<sup>2</sup>

The maximum length of the analogue output cable in voltage is:

- 50 m with cable 2 x 0,25 mm<sup>2</sup>
- 75 m with cable 2 x 0,5 mm<sup>2</sup>
- 150 m with cable 2 x 1 mm<sup>2</sup>

## 1.2 EARTHING SYSTEM

For the right earthing and the optimal functioning of the system, it is necessary to create a point of ground in proximity to the indicator, on which connect the earth of the indicator and the relative shielded cables (see "Point of ground of the indicator"). Connect the earth point of indicator, load cells and weighing structure directly to the earth bar (if present) of the electric panel or to an earthing pole, depending on the type of application; this point will be called point of common ground.

### POINT OF GROUND OF THE INDICATOR

Create a point of ground in proximity to the indicator, on which one connects the earth of the indicator and the shielded cables connected (load cell cable, serial ports cables, etc.). For example one can use an end connector terminal block, then connect this point to the ground using a cable having a 4mm<sup>2</sup> cross-section.

#### NOTES:

- Connect the terminal 2 (GND) to earth with a ground cable having a cross-section as large as possible (maximum cross-section supported: 2,5 mm<sup>2</sup>).

### LOAD CELLS AND JUNCTION BOX

- In the case the load cells are connected to the indicator through a junction box, it is necessary to connect the sheathing of the cells cables and indicator cable to the earthing of the junction box (refer to the junction box manual) and connect this to the earth.
- If the load cells are directly connected to the indicator (without the junction box), it is necessary to connect the sheathing of the cell cables directly to the point of common ground, using a cable having a 4 mm<sup>2</sup> cross-section, if the point of common ground is a few meters away, otherwise through a copper cable having at least a 16 mm<sup>2</sup> cross-section, for longer distances.

Moreover in both cases it is required to:

- Connect the upper side of every cells to the lower side using a copper braid having at least 16 mm<sup>2</sup> cross-section; the upper side must be short-circuited with the surface of the weighing structure and the lower one must be connected to the earth using a copper braid having at least 16 mm<sup>2</sup> cross-section.
- Use earth plate of suitable length, in order to obtain a total resistance of earthing plant lower than 1 Ω.

### WEIGHING STRUCTURE

Connect the weighing structure and the possible connected structures (for example silos that release material on the weighing structure) to the earth through copper cables having at least a 16 mm<sup>2</sup> cross-section.

#### NOTES:

- In the case the weighing system regards great and/or outdoor structures, the cross-section must be greater (for example 50 mm<sup>2</sup> instead of 16 mm<sup>2</sup> and 100 mm<sup>2</sup> instead of 50 mm<sup>2</sup>), because the voltages into play are greater (for example thunderbolts).
- In order to avoid possible undesired effects, if there are other shielded cable connected to the indicator (for instance, PC cable) the shield should be earthed only on the cable termination towards the indicator.
- Every shielded cable or not (for instance PC cable, cell cable, power supply cable) connected to the indicator should be as shorter as possible, then one has to come out of the shield the minimum length of cable, go three round around a ferrite ring and then connect to the terminal box.
- If the indicator is situated inside an electric panel, the power supply cable should be a shielded cable as shorter as possible, distant from every coil supply cable, inverter, electromotive force, etc. and in addition dedicate an uncoupler transformer in order to feed the indicator only.

# EARTHING EXAMPLE

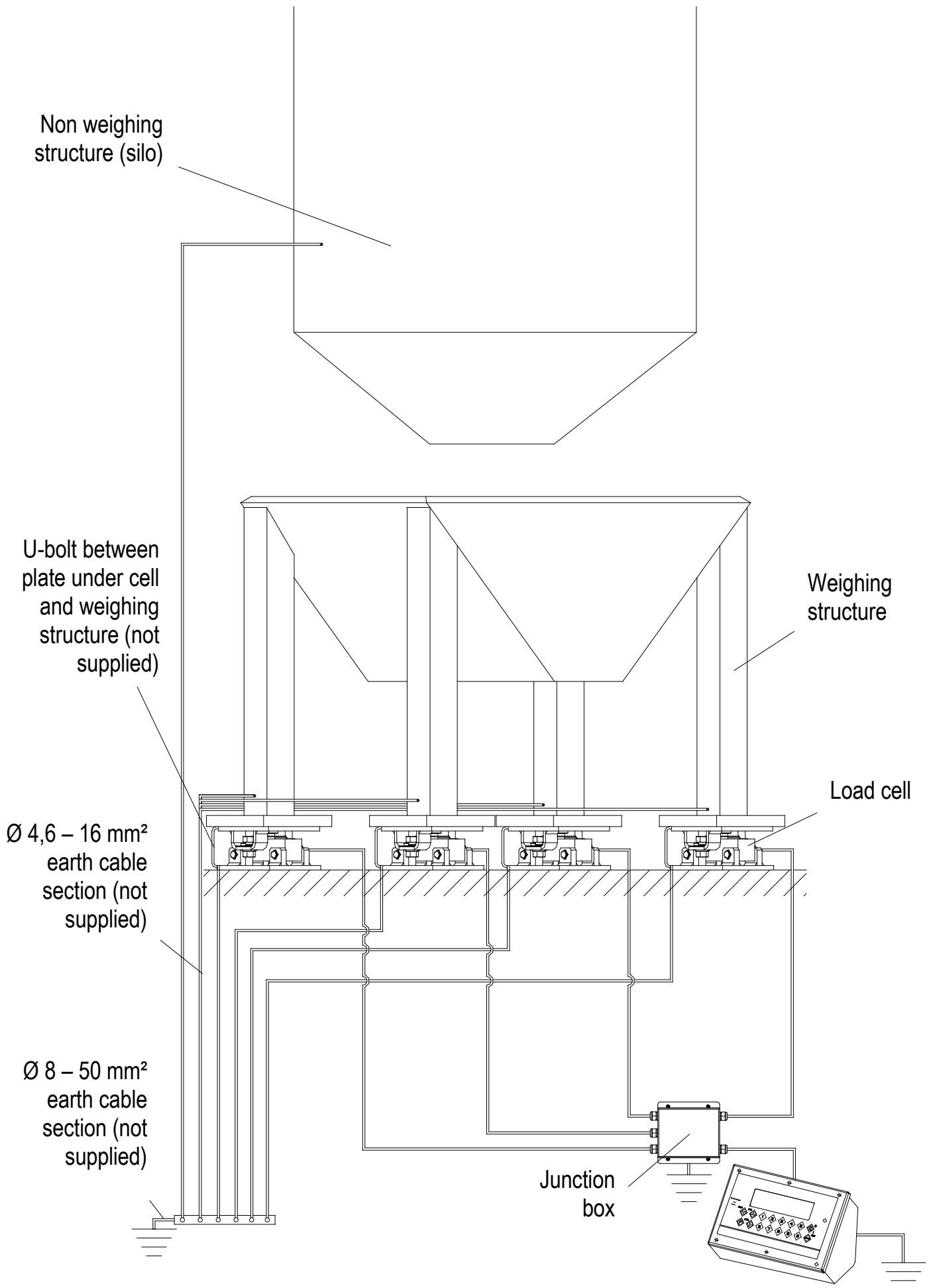

## 2. MAIN TECHNICAL SPECIFICATIONS

POWER SUPPLY	12÷24 Vdc +/-10% stabilized
MAXIMUM ABSORPTION (without load cells)	<b>SCT-100:</b> 100mA at 12V; 70mA at 24V <b>SCT-100AN:</b> 185mA at 12V;90mA at 24V <b>SCT-100PB:</b> 410mA at 12V;220mA at 24V
OPERATING TEMPERATURE	From -15 to +40 °C.
DISPLAY DIVISIONS	10000e, 3 x 3000e for legal weighing,expandable up to 800.000 for internal use (with <b>minimum</b> signal coming from a 1,6mV/V cell).
CONVERSION SPEED	200 conv./sec with automatic selection.
MINIMUM VOLTAGE PER DIVISION	0.3 µV (approved instrument); 0.03 µV (non approved instrument).
COUNTING RESOLUTIONS	1'500'000 points (with input signal equal to 3mV/V).
DISPLAY	6 digits, h 20 mm
INDICATIONS	6 status indicator LEDs.
KEYBOARD	Waterproof 5-key keyboard
TARE FUNCTION	Subtractive possible on the entire capacity.
AUTO SWITCH-OFF FUNCTION	Programmable from 1 to 255 minutes, or disinserted.
LOAD CELL POWER SUPPLY	5Vdc ± 5%, 120mA (up to 8 cells of 350 Ohm each).
LOAD CELL CONNECTION	6 wires (CELL1) with Remote Sense, 4 wires (CELLS 2, 3, 4).
CASE	PAINTED STEEL case with adjustable bracket (standard fitting) or fixed bracket (OPTIONAL) for mounting on the wall.
SERIAL OUTPUTS	<u>1 RS485 bidirectional port</u> configurable for connection to a PC/PLC or WEIGHT REPEATER (SCT-100 and SCT-100AN versions). <u>1 RS232 bidirectional port</u> configurable for connection to a printer. <u>1 PROFIBUS port</u> (SCT-100PB version).
OUTPUTS / INPUTS	<u>2 photomofet outputs</u> NO or NC, configurable programmable weight thresholds:48 Vac 0,15 A max(or 60 Vdc 0,15 A max) <u>2 configurable inputs (optoisolator photocouplers):</u> 12÷24 Vdc, 5 mA min - 20 mA max Input reading time and output refreshing time: 1msec. <u>Optoisolated analogue output</u> at 16 bit (at choice 4÷20 mA, 0÷5 Vdc or 0÷10Vdc (SCT-100AN); the maximum resistance applicable on the output current is 350 Ohm and the minimum resistance applicable on the output voltage is 10 kohm.
LOAD CELLS	Maximum full scale output: 6 mV/V

### 3. CONNECTION TO THE LOAD RECEIVER

#### CONNECTION TO 7 PIN LOAD CELL CONNECTOR

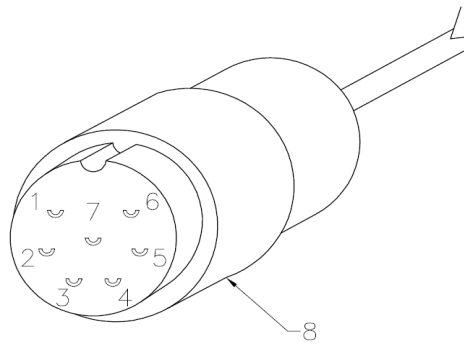

- 1 EXCITATION +
- 2 EXCITATION -
- 3 SENSE -
- 4 SENSE +
- 5 SIGNAL -
- 6 SIGNAL +
- 7 NOT CONNECTED
- 8 SHIELD TO BE FOLDER AND PLACED UNDER THE CONNECTOR CABLE TIGHTENER

After having followed the instructions regarding the platform or the load receiver, the screened cable leading from the load cell(s) must be connected to the instrument terminal board(s) (from CELL1 up to CELL4, see paragraph "CONNECTION SCHEMES") through the relative input(s) (see paragraph "INSTALLATION", **USER MAN. REF.**).

The CELL1 terminal board of the indicator may be connected to the 6-wire load receiver (with use of SENSE), instead for CELL2, CELL3 and CELL4 it's allowed only the 4-wire connection.

The sense allows compensating for any drops in voltage in the part of the cable that connects the instrument to the transducer. It is useful when the distance between the indicator and the transducer is greater than 10 m.

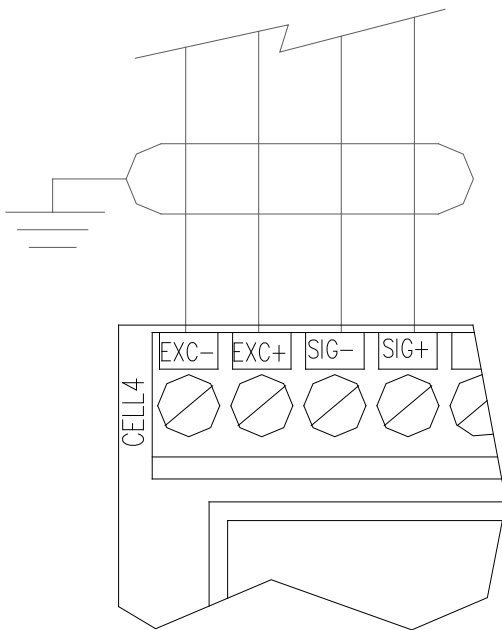

**4-WIRE CONNECTION**

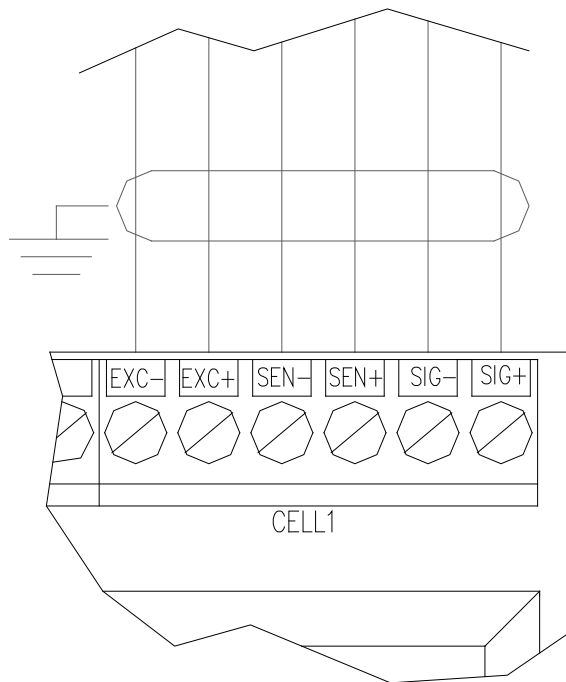

**6-WIRE CONNECTION**

#### !! IMPORTANT !!

- If one wants to use 4 wires in the CELL 1 terminal board (without using the SENSE signal), one should short-circuit -SEN with -EXC and +SEN with +EXC.
- When there are 6-wire cells:
  - 1) the SENSE is managed exclusively in systems with just one cell, connected to the CELL1 terminal board; in these applications, open the J1 and J2 jumpers
  - 2) in systems with various cells, the SENSE is not managed, therefore for each cell:
    - Short-circuit the +SENSE wire with the +EXC wire and the -SENSE wire with the -EXC wire; otherwise one may leave the SENSE wires unconnected.
    - Close the J1 and J2 jumpers.

## 4. SETUP ENVIRONMENT

With "SETUP ENVIRONMENT" we intend a specific menu, inside which it's possible to set all the functioning parameters of the indicator.

**To enter it, turn on the instrument and, while the firmware version is displayed , press the TARE key for an instant.**

**The indicator shows the first parameter "TYPE".**

**NOTE: THE METROLOGICAL PARAMETERS of the SETUP ARE normally NOT ENABLED and therefore are just displayed.**

**To enable them, open the instrument and activate the special micro switch (see paragraph "CONNECTIONS SCHEMES") and then turn it on.**

### **Functions assumed by the keys in the SET-UP ENVIRONMENT:**

<b>ZERO</b>	Scrolls the programming steps forward in sequence. If one needs to enter a numeric value, this decreases the digit to be modified (blinking).
<b>TARE</b>	Allows to scroll backwards through the programming steps. In the case in which one enters a numeric value, the selected digit (blinking) increases.
<b>MODE</b>	Allows to quickly position on the first step of a menu. In the case in which one needs to enter a numeric value, select the digit to be modified (blinking) from left to right.
<b>PRINT</b>	Allows to enter a step or confirm a parameter inside a step.
<b>C-ON/OFF</b>	Allows to exit a step without confirming the possibly modified parameter and go to the preceding level. When entering a numeric value it quickly zeros the displayed value.

**The display indicates the abbreviation of the step whose meaning is described below.** The values indicated with the (!) symbol at the end of the step, are values set by DEFAULT.

**TO EXIT THE SET-UP ENVIRONMENT, PRESS THE C - ON/OFF KEY MANY TIMES UNTIL THE INDICATOR SHOWS "SLUEP" IN THE DISPLAY: CONFIRM WITH PRINT TO SAVE ANY CHANGES MADE OR PRESS ANOTHER KEY TO NOT SAVE.**



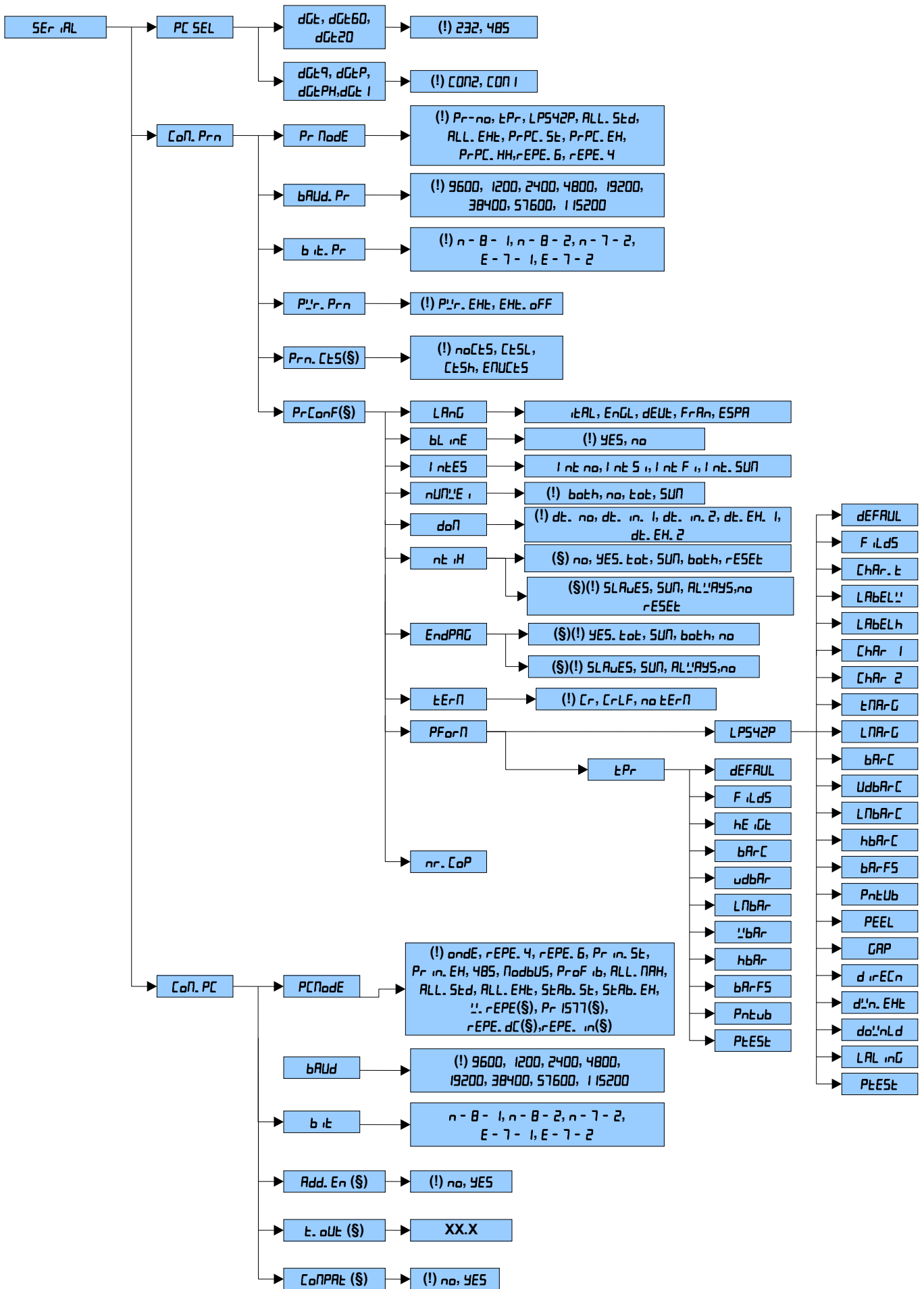

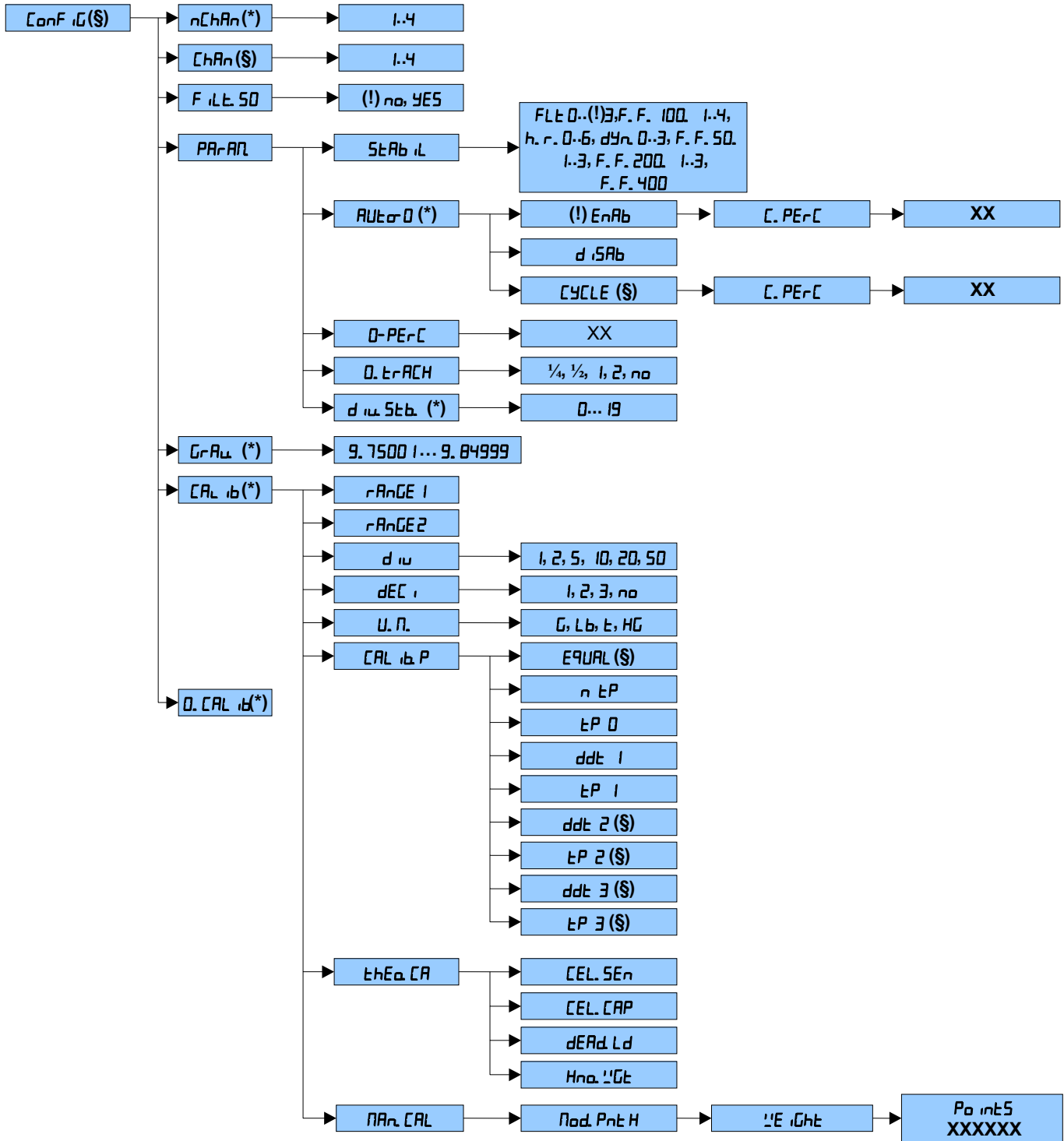

(§) = shows that the parameter is visible only in certain programming conditions; see the explanation of the parameter for the details.

(\*) = shows that with an approved instrument the parameter is not visible or not enterable; see the explanation of the parameter for further details.

## 4.2 DESCRIPTION OF THE STEPS

### (\*) TYPE TYPE OF APPLICATION (§)

One selects the type of application which will be made: scale with independent channels, a scale with dependent channels (could be digitally equalized) or scale with independent channels simultaneously viewable on the PC.

- **ind.Ch** = Instrument connected to 1, 2, 3 or 4 independent scales.
- **dEP.Ch** = Instrument connected to a scale with 2, 3, or 4 dependent load cells (could eventually be digitally equalized through a specific software procedure).
- **TRANSP** = Independent channel mode which makes it possible to have a transmission, through the serial line, of the values read by each single channel (for further details see section "SIMULTANEOUS TRANSMITTER OF THE CHANNEL VALUE (TYPE: TRANSP)", **USER MAN.REF.**).

**NOTE:** The configuration and the calibration of the instrument are done the same way as with the independent channel mode.

(!) **ind.Ch**

(\*) With approved instrument the parameter is read-only.

(§) The parameter is displayed only in the STANDARD type firmware.

### F. MODE SCALE FUNCTIONING

#### FUNCTION FUNCTIONING MODE (§)

➤ **Std** = Unit of measure conversion.

➤ **netGS** = Net weight / gross weight conversion.

➤ **input** = Input / output weigh.

Once the in / out mode is selected, "TYPE" is displayed for an instant and then one is asked to select with PRINT the print mode of the acquired data:

- "G. t." = **gross/tare**

- "1st. 2nd" = **first weigh/second weigh**

- "in. out" = **input/output**

➤ **MASTER** = Multiscale repeater.(\*\*)

By selecting with **PRINT** this functioning mode, one is asked to enter the number of SLAVES to be used: for an instant "NUMSL" is displayed; then enter the number (between 01 and 32). After that, one will be asked to choose the listen only master or not and set the protocol and slave keyboard which is needed to be controlled.

➤ **ALibi** = Alibi memory.

➤ **rEPE** = Single scale repeater.(\*\*)

➤ **u.155** = Sensitivity times ten.

➤ **hLd** = Freezing of the weight on the display.

➤ **PEAK** = Peak detector.

➤ **tot o** = Horizontal totalizer.

Once the horizontal totaliser functioning mode is selected, one needs to select the type of totalisation: normal (**t.norN**), fast (**t.FAST**) or automatic (**AUTO**).

➤ **tot S** = Vertical totalizer.

Once the vertical totaliser functioning mode is selected, one needs to select the type of totalisation: normal (**t.norN**), fast (**t.FAST**) or automatic (**AUTO**).

➤ **COUN** = Counting.

Once the Counting functioning mode is selected, one needs to select the Unit of Measure of the average piece weight (APW): *g / kg / t / Lb*, and the sampling interval in seconds (**TA t.t**).

(!) **netGS**

(§) The parameter is not displayed if one has set "TRANSP" in the **TYPE** parameter.

(\*\*) "MASTER" and "rEPE" are the only parameters displayed in the MASTER type firmware.

## NOTES:

For the functioning details, refer to section "SELECTABLE FUNCTIONING MODES", **USER MAN.REF.**.

Once the functioning mode is selected, if there's a printer, the standard printout relative to the printer selected in the *SEtUP* → *SErIAL* → *CoN. Prn* → *Pr. ModE* parameter will automatically be enabled. One can load the default parameters by executing the default of the selected printout (see section "PROGRAMMING THE PRINTOUTS").

### • *Scr. SAU* SCREEN SAVER (§)

If the indicator has the date/time option, it is possible to enable the "Screen Saver" function: after a programmable time (from 1 to 255 minutes) that the scale is unloaded, the time is shown on the display, in the "HH-MM.SS" format. As soon as a weight variation is detected, or a key is pressed, the indicator displays the current weight once again.

- *no* = Disabled.
- *YES* = Enabled: one is asked to enter the time which the indicator waits to display the time, after the weight has become stable and keys are not pressed.

(!) *no*

(§) The parameter is not displayed if there is no date/time option or if one has selected the rPE functioning mode, *F. ModE* → *FUnct* parameter.

**NOTE:** The date/time function is standard fitted in the DGTP/DGTPK version.

### • *ir. Conf* REMOTE CONTROL CONFIGURATION (§)

If the instrument has an infrared ray interface, with a remote control (optional) it is possible to remote some function keys:

- *nonE* =Remote control disabled.
- *ir 1* =4 Keys infrared remote control. All the remote control keys work as the TARE key.
- *ir 4* =4 Keys infrared remote control. The remote control keys work as ZERO, TARE, MODE and ENTER/PRINT.
- *rd 1* =6 Keys radio remote control. All the remote control keys work as the TARE key.
- *rd 6* =6 Keys radio remote control. The remote control keys work as ZERO, TARE, MODE, ENTER/PRINT, C and Fn.
- *rd. br 1* =6 Keys radio remote control. All the remote control keys work as the TARE key.
- *rd. br 6* =6 Keys radio remote control. The remote control keys work as ZERO, TARE, MODE, ENTER/PRINT, C and Fn.

(!) *nonE*

(§) The parameter is displayed with the DGT60 and DGT100 models.

**NOTE:** In the "*rd 1*" and "*rd 6*" configurations it's possible to combine 3 remote controls (**USER MAN.REF.**).

In the "*rd 1*" and "*rd 6*" configurations all the radio remote controls we provide work with the instrument.

### • *rEAct* REENABLING OF THE PRINTOUTS AND THE INDICATOR FUNCTIONS (§)

While using the indicator, it is possible to incur in the "*no. D. UnS*" error shown on the display; this means that the printout or the function which one wants to carry out must be reenabled (in order to avoid accidental executions). It is possible to set the reenabling in the following modes: "passage of the net weight by zero", "weigh instability" or "always".

- *ZEro* =passage of the net weight by zero
- *inst* =instability
- *ALWAYS* (§) =always (§) This parameter is not visible if by selecting the horizontal totaliser or vertical totaliser functioning mode one sets the automatic totalisation mode.

(!) *ZEro*

(§) The parameter is displayed only in the STANDARD type firmware.

- L. int DISPLAY BACKLIGHT INTENSITY (§)

Not Available on SCT-100

- CLoCH DATE/TIME ADJUSTMENT (OPTIONAL) (§)

In this step one sets the date and time of the indicator; by pressing PRINT one is asked to enter, in this order, the day, month, year, hour and minute.

The entry of each parameter must be confirmed with PRINT.

(§) The parameter is not displayed if there is no date/time option or if the rEPE functioning mode has been selected, *F. ModE* → *FUnCt* parameter.

**NOTE:** The date/time function is standard fitted in the DGTP/DGTPK version.

- tARE LOCKED / UNLOCKED / DISABLED TARE SELECTION (§)

- *L o C H* = locked tare
- *UnLoCH* = unlocked tare
- *d iSAb* = disabled tare

See the "TARE OPERATIONS" section for further functioning details, **USER MAN. REF.**

(!) *L o C H*

(§) The parameter is displayed only in the STANDARD type firmware.

- AUtoFF AUTO SWITCH-OFF (§)

It is possible to enable the automatic switch off of the indicator (from 1 to 255 minutes), or disable it; the auto switch-off starts working when, **with unloaded scale**, the weight has not been moved or a key has been pressed during the set time: the display shows the blinking "- oFF-" message, then the indicator turns off.

- *d iSAb* = auto switch-off disabled.
- *EnAb* = auto switch-off enabled (one will be asked to enter the number of minutes after which the indicator must turn off: enter a number from 1 to 255).

(!) *d iSAb*

(§) The parameter is not displayed if one has selected the rEPE functioning mode in the MASTER type firmware, *F. ModE* → *FUnCt* parameter.

- r5. zERo ZERO RESTORE (§)

By enabling the zero restore, when the zero function is performed the zero offset is stored; at the startup, if the autozero fails, or it is disabled, the zero offset is restored, so the scale will show the weight value that it had at the shutdown moment.

- *d iSAb* = zero restore disabled.
- *EnAb* = zero restore enabled

(!) *d iSAb*

(§) parameter is not displayed if one has selected *tRAnSn* in the *tYPE* parameter.

## SETUP SCALE CONFIGURATION

### • CONF IG METRIC CONFIGURATION (§)

(§) The parameter is displayed only in the STANDARD type firmware.

#### - (\*) nChAn SELECTION OF NR. OF INDICATOR CHANNELS (§)

- 1÷4 in SCALE WITH NON DEPENDENT CHANNELS functioning mode ("ind. Ch" / "trAnSf")

- 2÷4 in SCALE WITH DEPENDENT CHANNELS functioning mode ("dEP. Ch")

(!) Ch. 1

(\*) With approved instrument the parameter is read-only.

#### - ChAn SELECTION OF THE ACTIVE CHANNEL (§)

- 1÷4 in SCALE WITH NON DEPENDENT CHANNELS functioning mode ("ind. Ch" / "trAnSf")

(§) The parameter is not displayed if one has set "dEP. Ch" in the TYPE parameter or in case of a single channel application, SETUP → CONF IG → nChAn step.

#### - FLt. 50

By pressing the PRINT key, one can enable/disable the 50 Hz filter.

- no = disables the 50 Hz filter

- YES = enables the 50 Hz filter

#### - PARAM. METRIC PARAMETERS

##### - StAb IL FILTER INTEGRATION

By pressing the PRINT key one accesses the selection of the type and degree of filter intervention for the stability of the weight indication:

▪ FLt 0 ÷ 3 = Filter for simple weighing

▪ F. F. 100. 1 ÷ 4 = Filter for dosage at 100 Hz

▪ h. r. 0 ÷ 6 = Filter for high resolution

▪ dYn. 0 ÷ 3 = Filter for crane scale

▪ F. F. 50. 1 ÷ 3 = Filter for dosage at 50 Hz

▪ F. F. 200. 1 ÷ 3 = Filter for dosage at 200 Hz

▪ F. F. 400 = Filter for serial conversion/transmission at 400Hz

▪ CUStOñ = Customizable filter for use of the manufacturer

The higher the filter value, and greater is its intervention relative to the type of filter used.

(!) FLt 3

(\*) With approved instrument, one can select only the FLt 0, FLt 1, FLt 2, FLt 3 parameters.

**NOTE:** The F. F. 200. 1 ÷ 3 and F. F. 400 filters are not usable in the "dEP. Ch" 2, 3 and 4 channel functioning mode.

##### - (\*) AUtO-0 AUTO ZERO AT THE START UP

Automatic acquisition of the gross zero at the start-up (up to +/- 10% of the capacity):

- EnAb = Enabled on scale 1

- d, sAb = Disabled

- CYCLE (§) = Executed cyclically on all the present scales. (§) This value is not visible if there is just one scale (see nChAn parameter), or with more scales connected in a dependent way (see TYPE parameter).

If the auto zero is enabled, the "C. PERC" message is displayed and one is asked to enter the value as a % of the capacity of the autozero (included between 1 and 50).

(\*) In case of approved instrument, the settable values are between 1 and 10.

(!) EnAb 10

##### - (\*) 0-PERC ZERO CAPACITY

This menu allows to set the % of the action capacity of the ZERO key. The settable values are in between 0 and 50. By entering the 0 value, the ZERO key is disabled.

(\*) In case of approved instrument, the settable values are between 0 and 2.

(!) 2

- (\*) 0. ErACH ZERO TRACKING

This menu allows setting the zero tracking, in other words, the compensation parameter of the scale's thermal drift; the set value corresponds to the number of divisions that is reset in the fixed time of 1 second.

- Er. 1/2 = +/- half division.
- Er. 1/4 = +/- one fourth of a division.
- Er. 1 = +/- one division.
- Er. 2 = +/- two divisions.
- Er. no = tracking disabled.

(!) Er. 1/2

(\*) In case of approved instrument, it's possible to select only the Er. no, Er. 1/2 and Er. 1/4 parameters

- (\*) d w. Stb DIVISIONS BY STABILITY

In this step one enters the number of divisions by which the instrument detects the weight stability; the higher the number of divisions, less is the sensitivity, and consequently the stability is more easily detected. The possible values are 0 (weight always stable)...99.

(!) 2

(\*) With approved instrument the parameter is read only.

- (\*) GrAu. GRAVITY ACCELERATION AND OF USE

Through this step one selects the acceleration value **of calibration and of use** of the instrument:

Manual entry of the g value: one may manually enter the gravitational acceleration value; **one must modify the 6 decimal digits of the gravitational acceleration.**

In case one enters a wrong g value: the minimum decimal value is suggested (9,75001); a wrong value is any decimal number that is not between 9,75001 and 9,84999 (inclusive).

(!) g = 9,80655

(\*) With approved instrument the parameter is read-only.

- (\*) CAL ib SCALE CALIBRATION

See paragraph "SCALE CALIBRATION".

(\*) With approved instrument the parameter is read-only.

- (\*) 0. CAL ib ZERO CALIBRATION

See paragraph "SCALE CALIBRATION".

(\*) The parameter is not displayed if the instrument is approved.

• dSP. rF DISPLAY REFRESH

It is possible to slow the speed of the display refresh improving the stability of the displayed data:

- norfl. = The function of improving the stability of the displayed data is disabled
- 20Hz = 20 display / sec refreshments
- 10Hz = 10 display / sec refreshments
- 5Hz = 5 display / sec refreshments
- 2.5Hz = 2,5 display / sec refreshments
- 1Hz = 1 display / sec refreshment

**Note:** This parameter affects only the displaying.

- 5Er AL SERIALS, PRINTOUTS, ETC...

- PC 5EL PC SERIAL SELECTION

Through this step one can select the PC serial port and therefore invert the serial ports.

- **485** = The communication between the indicator and the PC takes place through the RS485 (or PROFIBUS port with the **SCT-100PB** models) while the transmission of the data to the printer takes place through the RS232 port.
- **232** = The communication between the indicator and the PC takes place through the RS232 port while the transmission of the data to the printer takes place through the RS485 port or does not take place for the **SCT-100PB** models.

(!) **232**

- CoП. PpH PRINTER SERIAL

- Pp. ПодE TRANSMISSION UPON THE PRINTER SERIAL

- **Pp- no** = transmission disabled.
- **EPp** = enables the printing with ASCII printer (for example DP190 or TPR).
- **LP542P** = enables to print with labelling machine LP542S
- **ALL. Std** = continuous transmission with standard string.
- **ALL. EHt** = continuous transmission with extended string (or multiscale string in the TRANSM mode).
- **PpPC. St** = transmission of the standard string upon the pressing of the PRINT key.
- **PpPC. EH** = transmission of the extended string upon the pressing of the PRINT key.
- **PpPC. HH** = transmission of the weight string upon the pressing of print key (when the weight is stable)  
**NOTE:** if the "TOTALIZER" mode (horizontal or vertical) is active, the transmission through the key is carried out by pressing the MODE key.  
The transmission of the standard or extended string upon the pressing of the PRINT key is confirmed by "E-PrH5H" on the display.
- **rEPE. 6** = transmission to 6-digit remote display.
- **rEPE. 4** = transmission to 4 digit remote display.

(!) **Pp- no**

**Notes:**

- By selecting the **rEPE. 6** protocol the serial output is automatically set at 4800, N-8-1. In any case it's possible to set it differently.
- In the multiscale repeater functioning mode (see the section "MULTISCALE REPEATER (**ПР5EП**)", **USER MAN.REF.**) for the printer port the transmission modes are enabled to the printer and the "rEPE.6/rEPE.4" transmission mode.
- If one wants to use the LP542S printer, select the LP542P item.

For the protocol and transmission mode specifications, see section "SERIAL PORT TRANSMISSION MODES" and "TRANSMISSION PROTOCOLS".

- **bAUD.Pr** SET BAUD RATE

By pressing the PRINT key one accesses the selection of the data transmission speed (measured in Baud = bit/second). The possible values are:

- 1200
- 2400
- 4800
- 9600
- 19200
- 38400
- 57600
- 115200
- (!) 9600

- **bit.Pr** SET PARITY, WORD, STOP BIT

By pressing the PRINT key one accesses the selection of the available values:

- n-8-1
- n-8-2
- n-7-2
- E-7-1
- E-7-2
- (!) n-8-1

- **Pr.Prn** SETTING PRINTER MANAGEMENT

In this step one programmes the management of a possible connected printer:

- **Pr.EHt** = with instrument on, printer managed.
- **EHt.OFF** = printer managed; the start-up characters are sent to the printer, because the printer is considered to be configured in the energy saving mode.
- (!) **Pr.EHt**

- **Prn.CtS** RTS/CTS STATUS CONFIGURATION (§)

On the printer serial line the indicator has a CTS input (Clear To Send). A device (like a printer) that is slow in processing the data received, can interrupt the transmission temporarily using this signal.

- **noCtSno** = signal
- **CtSLCTS** = active low (for LP542, TPR, DP24 printers)
- **CtSh** = CTS active high (for DP190 printers)
- **EmULCtS** = Emulation of the CTS signal: one is asked to enter the number of characters (**nChrS**), in 3 digits, which will be transmitted to the printer upon each transmission; then one needs to enter the waiting time in milliseconds (**tME**), in 4 digits, between a transmission and another.

The TIME OUT of a printout is a minute, in other words, after a minute that the printout is blocked, it is cancelled.

(!) **noCtS**

(§) The parameter is not displayed unless "**tPr**" or "**LP542P**" has been selected in the "**Pr.NoDE**" step.

- **Pr.ConF** CONFIGURATION OF THE PRINTOUTS (§)

See the "PROGRAMMING THE PRINTOUTS" section for the description of all the menu's parameters.

(§) The parameter is displayed only if "**tPr**" or "**LP542P**" has been selected in the "**Pr.NoDE**" step and single scale repeater mode ("**rEPE**") is not enabled (in the MASTER type firmware).

- **Con.PC** PC SERIAL

- **PCModE** TRANSMISSION ON THE PC SERIAL (§)

(§) In the MASTER type firmware, this step is not displayed if the "**PRStE**" functioning mode has been set in the **F.NoDE** → **FunctE** step; if the "**rEPE**" mode has been set, only the "**rEPE.dC**", "**Pr.1577**", "**rEPE.5**" and "**rEPE**" and "**R.rEPE**" parameters are displayed.

- *andE* = transmission on external command PC (given from PC or PLC, for example)
- *rEPE.4* = transmission to 4 digit remote display.
- *rEPE.6* = transmission to 6 digit remote display / Reception of the "rEPE.6" string.
- *Pr in. St* = transmission of standard string when the PRINT key is pressed.
- *Pr in. EH* = transmission of extended string when the PRINT key is pressed.  
**NOTE:** if the "TOTALIZER" mode (horizontal or vertical) is active, the transmission through the key is carried out by pressing the MODE key.  
 The transmission of the standard or extended string upon the pressing of the PRINT key is confirmed by "trAnSM" on the display.
- *485* = transmission with 485 protocol, by confirming with PRINT, one is required to enter the machine code (the message "Ad485" appears for an instant): enter a value between 0 and 98.
- *ModBUS* = Transmission with the MODBUS protocol
- *Prof ib* = Transmission with the PROFIBUS protocol
- *ALL. Std* = continuous transmission with standard string.
- *ALL. EHt* = continuous transmission with extended string (or multiscale string in the TRANSM mode).
- *StAb. St* = transmission with each weigh with standard string.
- *StAb. EH* = transmission with each weigh with extended string (or multiscale string in the TRANSM mode).
- *rEPE.dC (\$)* = transmission protocol (\$) The parameter is displayed only if one has selected the rEPE functioning mode in the *F. ModE → FunCt* step, with the MASTER type firmware.
- *rEPE. in(\$)* = Transmission protocol that allows you to manage the received string automatically without setting any parameters. (\$) The parameter is displayed only if one has selected the rEPE functioning mode in the *F. ModE → FunCt* step, with the MASTER type firmware.
- *A. rEPE (\$)* = Transmission protocol that allows you to receive an ASCII string. This way you can display both numbers and letters. The parameter is displayed only if one has selected the *rEPE* functioning mode in the *F. ModE → FunCt* step, with the MASTER type firmware.
- *!! rEPE (\$)* = Reception of string from remote scale. (\$) The parameter is displayed only if one has selected the rEPE functioning mode in the *F. ModE → FunCt* step, with the MASTER type firmware.  
 By confirming with **PRINT** one is requested to set the following parameters for the management of the remote scale:

- **!Ern** REMOTE SCALE TERMINATOR

In this step one enters the decimal ASCII code (up to 2 characters) of the terminator characters of the weight string (I.E. 13 for CR or 10 for LF).

(!) 01

- **!E . Pos** REMOTE SCALE WEIGHT POSITION

In this step one sets the position of the first character of the weight value, in the string transmitted by the remote scale, knowing that the first character on the left of the string has the 00 position.

A possible character sign is also part of the weight value.

For example, if the received string is **sppppppuu + CR + LF:**

Received string	s	p	p	p	p	p	p	p	u	u	CR	LF
Position of the character	00	01	02	03	04	05	06	07	08	09	10	11

Therefore one should set the 00 value.

It is possible to set up to 2 characters (from 0 to 39).

(!) 00

- **!E . LEN** LENGTH OF THE WEIGHT DATA STRING

In this step one enters the number of digits (from 1 to 39) which make up the weight value, including the sign and the non significant digits (for example, if the transmitted string **sppppppuu + CR + LF**, in which

**s** is the weight sign, **ppppppp** is the weight value, **uu** is the unit of measure, one should set the 08 value).  
(!) 0 1

○ Str.LEn LENGTH OF THE COMPLETE STRING

In this step one enters the number of digits (from 0 to 39) which make up the entire string transmitted from the serial line scale, less the terminator character (for example, if the transmitted string is **spppppppuu + CR + LF**, in which **s** is the weight sign, **ppppppp** is the weight value, **uu** is the unit of measure, one should set the value 11).

(!) 00

○ dEC REMOTE SCALE DIVISIONS

Enter the number of scale's decimals (from 0 to 5).

(!) 0

○ Unit REMOTE SCALE UNIT OF MEASURE

Enter the unit of measure (G, Lb, t, HG).

(!) G

The two following parameters allow to generate the weight stability communicated by the remote scale and allow to manage the stability LEDs on the indicator:

○ StAb NUMBER OF READINGS PER STABILITY

Enter the number of consecutive readings which the indicator must consider to obtain the stability (2 characters, from 0 to 20).

(!) 00

**NOTES:** If you set 00, the check is disabled

○ StA.int WEIGHT DIFFERENCE PER STABILITY

Enter the maximum value (2 characters, from 0 to 20) of the difference between the weights of the consecutive readings, set in the previous step.

If the weight difference between the readings is equal or less than the set value, the weight is considered to be stable (stability LED off), otherwise the weight is considered to be unstable (stability LED on).

(!) 00

○ trShLd SETTING MINIMUM AND MAXIMUM THRESHOLD

This step allows to enter minimum and maximum threshold for repeater mode. With **PRINT** key to enter, the display shows **tr.Lo** message, it indicates one is asked to enter minimum value, after this, **tr.hi** message is display, it indicates one is asked to enter maximum value.

When the weight received from remote scale is less than minimum value, the segment is displayed at the bottom of LED display; when the weight received from remote scale is more than maximum value, the segment is displayed at the top of LED display.

**NOTE:** MAX = 999999 MIN = -999999

(!) **tr.Lo** = -999999; **tr.hi** = 999999

○ Adv.CEd ADVANCED

With this parameter is possible to set the individual bits of the receipt string for the sign, stability, zero and over/under load management.

→ **!.nEt** = The string position that indicates if the weight is net.

→ **nEG.SI G** = The string position that indicates if the weight is positive or negative.

→ **StAbi L** = The string position that indicates if the weight is stable.

→ **!.ZER0** = The string position that indicates if the weight is inside to +- 1/4 of division respect to 0 (ZERO led on)

→ **Und. Dur** = The string position that indicates if the weight is over/under load

In every parameter that are described on, you'll need to set the following settings:

- **ПР5Н** byte where will extract the data, relative to step indicated in ADV.CED (from 0 to 255).  
**NOTA:** to setting zero, the parameter is not managed.
- **п. бУдЕ** indicates the character where the data will be extract
- **УРЛУЕ:** character value that defines what was selected in ADV.CED step.  
If the character of the string is a letter, it is necessary to insert the relative ASCII code value

#### NOTES:

- **Und. Оур=** if it is setted, the **тr. LO** and **тr. HI** parameters will be ignore.  
If it is setted the scale is considered to be in under load if the weight is less or equal to zero, otherwise it is considered to be in over load.
  - **StAb=** if this parameter is setted, STABIL settings, in the advanced submenu, are ignored.
  - **!! 2ErD=** if it is not setted (MASK = 0) the scale is considered to be in the zero range when the weight is equal to zero.
- **Pr 1577 (§)** Reception of the "Pr1577" string. (§) The parameter is displayed only if one has selected the rEPE functioning mode in the **F. ПодЕ → FUnCt** step, with the MASTER type firmware.

(!) **оndЕ**

#### NOTES:

- If the functioning mode selected in the **F. ПодЕ → FUnCt** step is different than rEPE, by selecting the REPE6 or REPE4 protocol the serial output is automatically set at 4800, N-8-1.  
By selecting the Pr1577 protocol the serial output is automatically set at 4800, E-7-1.  
In any case it's possible to set it differently.
- For the transmission modes and protocol specifications, see the "SERIAL PORTS TRANSMISSION MODES" and "TRANSMISSION PROTOCOLS" sections.

#### - **bAUd** SET BAUD RATE

By pressing the PRINT key one accesses the selection of the data transmission speed (measured in Baud = bit/second). The possible values are:

- 1200
- 2400
- 4800
- 9600
- 19200
- 38400
- 57600
- 115200

(!) 9600

#### - **b it** SET PARITY, WORD, STOP BIT

By pressing the PRINT key one accesses the selection of the available values:

- n-8-1
- n-8-2
- n-7-2
- E-7-1
- E-7-2.

(!) n-8-1

#### ➤ (§) **CoПРАt** ENABLE THE "DGQ" COMMUNICATION PROTOCOL

Not Available on SCT-100

- **Addr. En ENABLING AND SELECTING THE 485 SERIAL ADDRESS (§)**

In the rPE functioning mode, through the *F. ModE → Funct* parameter it is possible to enable the 485 protocol and links its own address to the instrument; the indicator will repeat the weight if the address in the received string is the same as the address set here.

- *no* = 485 protocol disabled.
- *YES* = 485 protocol enabled.

If one enables the 485 protocol, one is asked to enter the 485 address, on the display appears the message "Addr-*HH*" in which *HH* is the 485 address, from 00 to 99 (by pressing the **TARE** or **ZERO** keys one increases the digit, and with **MODE** it's selected; when the chosen values is reached, one confirms with **PRINT**).

(!) *no*

(§) The parameter is displayed only in the MASTER type firmware, if one has selected the rPE functioning mode and the "PCModE" step is set on "rPE. 6", "Pr 1577" or "rPE. dE".

- **t. oUt SETTING WAIT TIME FOR COMMUNICATION (§)**

In the "rPE" functioning mode, through this step, it allows to set timeout communication. If the wait time passes out, communication is disconnected yet, a segment is displayed at the center of LED display, which indicates it fails to set up communication.

**NOTE:** MAX=20. 0 sec; MIN=00. 5 sec

(!) 0 1. 5 sec

(§) The parameter is displayed only if one has selected the "rPE" functioning mode in the MASTER type firmware.

• **(\*) in i. AL INITIALIZES ALIBI MEMORY (§)**

The initialisation cancels all the data stored in the Alibi memory; by pressing PRINT one is asked to confirm the operation. The display shows "i. AL ib. P"; press PRINT again to confirm or another key to cancel.

At the end the "AL. 0H" message appears if the operation is made with success; otherwise the "AL. Err" message is displayed.

(§) The parameter is displayed only if the ALIBI functioning mode is selected, *F. ModE → Funct → AL ib i* parameter, in the STANDARD type firmware.

(\*) The parameter is not displayed with an approved instrument.

• **(\*) d. SCALE LIMITATION OF THE SCALE FUNCTIONS (§)**

- *no* = limitations disabled
- *YES* = limitations enabled

Refer to the user manual for the description of its functioning (**USER MAN.REF.**).

(!) *no*

If limitation is enabled, the display will shows *rEn. dSP* step.

- *no* = remote display disabled
- *YES* = remote display enabled

(!) *no*

(\*) The parameter is not visible with an approved instrument.

(§) The parameter is not displayed in the MASTER type firmware.

• **(§) inPUt5 INPUT CONFIGURATION**

In this step one sets the function to link to each input (n°2).

- **inP. 1: INPUT 1**

- *nonE* = Disabled
- *ZErO* = ZERO key
- *tArE* = TARA key
- *ModE* = MODE key

- Print = PRINT key
- C = C key; the simple pressing of the indicator key will be repeated
- oFF = TURNING OFF THE INDICATOR
- dIS. KEY = DISABLING OF KEYBOARD
- (!) none

- inp. 2: INPUT 2

The programming of the 2 input is done as described for input 1.

**NOTE:** In case various inputs are simultaneously enabled just the one with the lower number is taken into consideration.

• **(\$)OUTPUT OUTPUT CONFIGURATION**

In this step one sets the function to be linked to each output (n°2).

- out. 1 OUTPUT 1

- FUnC OUTPUT FUNCTION

- 0 none = No function
- 1 Gros = Set point on the Gross Weight (\*)
- 2 net = Set point on the Net Weight (\*)
- 2 Wght = Set point on the Weight (\*\*)
- 3 PCS = Set point on the Pieces (\*)
- 4 Gro. 0 = Gross Weight at zero (\*)
- 5 net. 0 = Net Weight at zero (\*)
- 5 Wght. 0 = Weight at zero (\*\*)
- 6 Inst. = Instability
- 23 H. Pr = Pressing of the PRINT key
- 25 H. Mod = Pressing of the MODE key
- 26 H. C = Pressing of the C - ON/OFF key
- 27 H. Zer = Pressing of the ZERO key
- 28 H. Tar = Pressing of the TARE key
- 29 Err = ERROR INDICATION
- 30. net. t = Set point on the Net Weight if the tare is activated(\*)

(\*) The parameter is displayed only if the firmware is STANDARD type.

(\*\*) The parameter is displayed only if the firmware is MASTER type.

- nornc NO/NC CONTACTS

- no = output 1 normally opened.
- nc = output 2 normally closed.

(!) no

- onStat SWITCHING CONDITION

- drct = the output is activated as soon as the weight reaches the set threshold, (independently from the stability) and is disabled in the moment in which the weight goes below the set disabling threshold.
- Stbl = the output is activated in the moment in which the weight, after reaching the set activation thresholds, becomes stable and is disabled in the moment in which the weight goes below the set disabling threshold, it becomes stable.

(!) drct

- rl. st HYSTERESIS

- st. oFF = Hysteresis disabled
- st. on = Hysteresis enabled

(!) st. oFF

- **E<sub>n</sub>Ab. t<sub>n</sub>** ENABLING TIME

One enters the length of the output enabling in seconds (4 digits with a decimal). The output is disabled once the set time has passed, starting from the moment of the activation (see following parameter). By setting "000.0" the output remains always active.

**Notes:**

- The delay time is considered only if one has selected the "Set point on gross weight", "Set point on Net weight" or "Set point on Pieces" as a output function.
- Once disabled, the output is only re enabled (before verifying again the enabling condition) if the disabling condition takes place.

(!) 000.0

- **dELAY** ENABLING DELAY PERIOD

One enters the enabling delay period in seconds (4 digits with a decimal).

The output is enabled once the set time has passed, starting from the moment in which the condition takes place. By setting "000.0" the output is enabled when the enabling condition takes place.

**Notes:**

- The output is enabled only if the enabling condition takes place for the length of time set.
- The delay is valid only for the enabling of the output. When the enabling condition no longer takes place the output immediately is disabled.
- With switching condition upon stability, the output is enabled only when, after the set time has passed, the weight shows to be stable.
- The delay time is considered only if one has selected the "Set point on gross weight", "Set point on Net weight" or "Set point on Pieces" as a output function.

(!) 000.0

- **S<sub>i</sub>Gn** SET POINT SIGN (§)

- **Pos it** = Functioning on positive weight.
- **negAt** = Functioning on negative weight.

(§) The parameter is displayed only if one has selected the "Set point on Net weight" or "Set point on Pieces" as function of an output.

The same configurations are valid for:

- **oUt. 2** = OUTPUT 2

• **An. oUt** ANALOGUE OUTPUT (SCT-100AN) (§)

See the section "ANALOGUE OUTPUT (SCT-100AN)" for configuring it.

(§) The parameter is not displayed if one has selected the **rEPE** functioning mode in the MASTER type firmware, **F. ModE → FunCt** parameter.

➤ **SLot** SELECTION OF THE SLOT (§)

Not available on SCT-100AN.

- **ChAn** SELECTION OF THE ACTIVE CHANNEL (§)

1÷4 in SCALE WITH NON DEPENDENT CHANNELS functioning mode ("**ind. Ch**" / "**trAn5n**") (§) The parameter is not displayed if one has set "**dEP. Ch**" in the **tYPE** parameter or in case of a single channel application, **SEtUP → ConF. iC → nChAn** step.

- **CAPAC.** SETTING OF SCALE'S CAPACITY (§)

In this step one has to enter the capacity set on the slave (from 000000 to 800000).

(§) The parameter is displayed only in the MASTER type firmware.

- **ModE** OPERATING MODE

(§) If the firmware is STANDARD type:

- **An no** = analogue output disabled.

- Ro Gro = analogue output on the gross weight.
- Ro net = analogue output on the net weight.

(§) If the firmware is MASTER type:

- Ro no = analogue output disabled.
- Ro YES = analogue output enabled.

(!) Ro no

- Ro MAX MAXIMUM VALUE

Setting of the maximum value of the analogue output (from 00000 to 65535).

- Ro Zer SCALE ZERO VALUE

Setting of the analogue output value when the scale displays zero weight (from 00000 to 65535).

- Ro Min MINIMUM VALUE

Setting of the minimum value of the analogue output (from 00000 to 65535).

- Sign SIGN (§)

- Pos it = Functioning with positive weight.
- negAt = Functioning with negative weight.

(!) Pos it

(§) In the STANDARD type firmware, the parameter is displayed only if one has selected the operating mode on the net weight. In the MASTER type firmware, the functioning on the negative weight is not managed.

• DEFAULT INITIALIZATION OF THE INSTRUMENT

Through this step one can initialize the instrument with the subsequent activation of the default parameters. By pressing PRINT, a confirmation message DEFAULT will appear: confirm again with PRINT or exit with any other key.

**NOTE: The initialization of the instrument causes a cancellation of the present calibration and the activation of the default parameters. In any case if one exits the setup environment WITHOUT CONFIRMING the modification made, all the parameters of the last saving made will remain (including the calibration).**

**In case of approved instrument, the default DOES NOT HAVE EFFECT on the metrological parameters those marked with (\*) ).**

## d ,RC DIAGNOSTICS MENU

It is a submenu inside which it is possible to check the software components and the scale hardware.

### - PrG. uEr CHECKING THE SOFTWARE VERSION

By pressing **PRINT** the instrument shows the software version in the XX.YY.ZZ. format.

### - d u. int CALIBRATION INTERNAL DIVISIONS (§)

By pressing **PRINT** the instrument shows the calibration internal divisions.

(§) The parameter is displayed only in the STANDARD type firmware.

### - AdC. Uu MICRO VOLTS (§)

By pressing **PRINT** the instrument shows the micro volts relative to the weight on the scale.

With the **ZERO** and **TARE** keys it is possible to switch the visualisation of the microvolts for each configured channel of the scale. In the "dEP. CH." mode it is also possible to view the sum of the microvolts of the configured channels ("SUM" appears for a few instants).

If the instrument displays the message "ErrOr" check the connection of the SCT-100 to the junction box and load cells.

**NOTE:** The maximum voltage that the instrument accepts in input is 30 mV (30000  $\mu$ V); the weighing system is powered by the indicator at 5 Vdc.

A correct operation will have a value less than 30000 with a weight of full scale capacity on the weighing system.

(§) The parameter is displayed only in the STANDARD type firmware.

### • AdC. Muu MILLIVOLTS/VOLT (§)

By pressing **PRINT** the instrument displays the millivolts/volt relative to the weight on the scale.

Through the **ZERO** and **TARE** keys it's possible to switch the display of the millivolts for each configured channel of the scale. With the **MODE** key one can execute the scale zero, while with **PRINT** one cancels.

If the instrument displays the message "ErrOr" check the connection of the SCT to the junction box and load cells.

#### **NOTES:**

- If the load cell isn't correctly connected, or if the signal of the load cell is incorrect, "ErrOr" is displayed for a few seconds, and then "ErrOr".

- In the "dEP. CH" or "tRANS" mode, if one channel is over the capacity, "Over C" is displayed, in which C is the number of the channel over the capacity. If more than one channel is over the capacity, "Over C" is displayed, in which C is the number of the channel with the lowest index.

(§) The parameter is displayed only in the STANDARD type firmware.

### • AdC. Pnt CONVERTER POINTS (§)

By pressing **PRINT** the instrument shows the A/D converter points relative to the weight on the scale.

With the **ZERO** and **TARE** keys it is possible to switch the display of the A/D converter points for each scale's configured channel. In the "dEP. CH" mode, it is also possible to view the sum of the microvolts of the configured channels ("SUM" appears for a few instants).

(§) The parameter is displayed only in the STANDARD type firmware.

### - WE. GHt WEIGHT (§)

By pressing **PRINT** the instrument shows weight value on the scale.

If various scales are connected independently by pressing the **ZERO** and **TARE** keys it is possible to select the scale to be checked.

(§) The parameter is displayed only in the STANDARD type firmware.

### - CAL. PLS CALIBRATION POINTS (§)

By pressing **PRINT** the instrument alternately shows A/D converter points and weight value corresponding to it, which have been executed in the calibration.

With the **ZERO** and **TARE** keys it is possible to switch the display of each executed calibration point and relative weight value.

### - d ,SPLA DISPLAY TEST

By pressing **PRINT** the instrument turns on all the display segments one at a time, after which it exits automatically from the step.

- HE4b. KEYBOARD TEST

By pressing **PRINT** the instrument displays 0000; by pressing the keys one at a time, the relative codes are brought again to the display. One exits pressing the same key three times.

- SEr RS232 SERIAL PORT TEST

By pressing **PRINT** the instrument displays "x 5 H4" in which x indicates the status of the printer serial port while y indicates the status of the PC serial port. Both can take on two values:

- 0 = Serial port does not work
- 1 = Serial port works

During the test one should short-circuit TX with RX (in the RS232 terminal).

Furthermore the ASCII "TEST"<CRLF> string is continuously transmitted on both the serial lines.

**CAREFUL:** It's not possible to test the functioning of the RS485 port.

- CT5. 5t. TEST OF THE CTS STATUS

By pressing **PRINT** one views the status/level of the CTS signal of the printer (on) connected to the PRN serial port.

• oUtPUt TEST OF THE OUTPUTS

By pressing **PRINT** the instrument displays "rEL. 1" and enables output 1; press the ZERO or TARE key to enable the other output.

• inPUt5 TEST OF THE INPUTS

By pressing **PRINT** the instrument displays "x. yH-4" in which x, y indicate:

x – the input which is controlling 1 and 2; to change the input which one wants to control press the ZERO or TARE keys.

y - the input status:

- 0 = Disabled input
- 1 = Enabled input

- An oUt ANALOGUE OUTPUT TEST

If the instrument is fitted with the analogue output (SCT-100AN only), through this step one can test if the values of the D/A converter (to be entered at time of calibration) correspond with the relative values of the analogue output (in voltage or in current), see the paragraph "ANALOGUE OUTPUT (OPTIONAL, AVAILABLE DEPENDING ON THE MODEL)".

By pressing **PRINT** the display shows 00000; enter a value between 00000 and 65535 and confirm with **PRINT**; the instrument will supply the corresponding analogue value in output.

To exit the test confirm twice with PRINT the same entered value.

• rotArY ROTARY SWITCH

Not available on SCT-100.

• SEr. nUN SERIAL NUMBER

Diagnostics check for use of the manufacturer.

• 5. rAd io RADIO CHANNEL CONFIGURATION

If you press **ENTER** you can select the radio channel that you want to use. You see "0H" if the configuration is successful, otherwise the display shows "Error"

• 5. 5cAn 485 NETWORK SCAN(\$)

Executes a 485 network scan on the set number of scales, skipping its own address. With up/down keys it is possible stop the automatic scan and manually change the active scale with the same up/down keys. With C key it is possible exit from the step.

(\$)The parameter is displayed only in the STANDARD type firmware. If the parameter Pc. Node → Pb. PUt is selected.

## 5. CALIBRATION

There are two possible types of calibration, depending on the type of application chosen for the instrument: for "ind. Ch" type (independent channels) and for "dEP. Ch" type (dependent channels, which could eventually be digitally equalized) (see the parameter: TYPE – Type of application).

**NOTE:** For the type of "TRANSM" functioning (see the parameter: TYPE – Type of application) the calibration procedure is the same as that of the scale with independent channels.

**IMPORTANT: with Approved Instrument**, the following parameters:

- are read only: "GrAu.", "rAnGE 1", "rAnGE 2", "d u", "dEC 1", "U. N.", "n tP", "ddt 1", "ddt 2", "ddt 3"
- are not displayed: "Q. CAL ib", "tP 0", "tP 1", "tP 2", "tP 3".

### 5.1 Calibration procedure for the INDEPENDENT CHANNELS and "TRANSM" modes

**Premise:** this procedure is to be followed if one has to calibrate from 1 to 4 independent scales, either in the "ind. Ch" or in the "TRANSM" functioning mode (see the parameter: TYPE – Type of application). Each single cell must be connected to an instrument channel; if one wants to connect more than four cells it will be necessary to equalize these externally using the junction box.

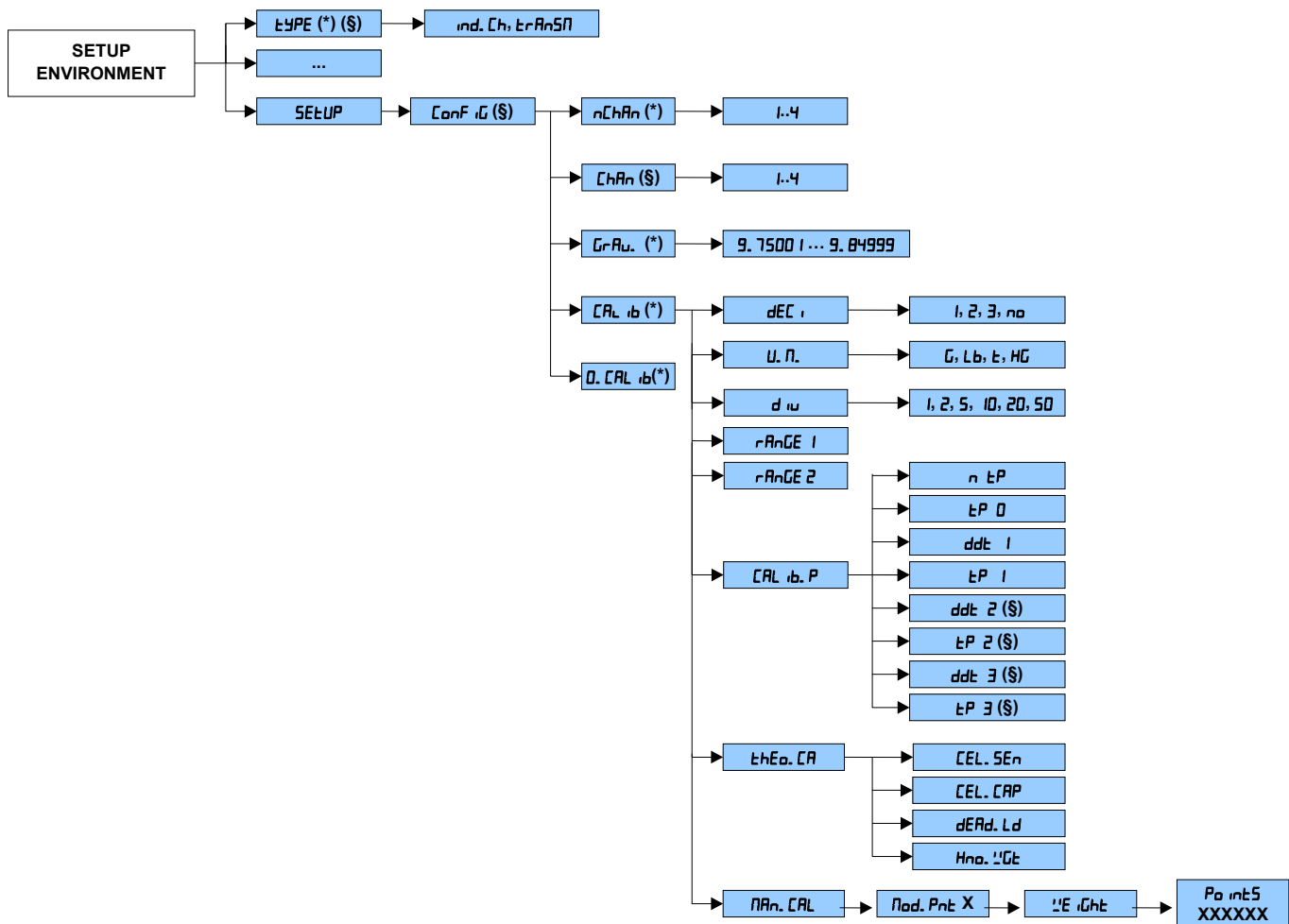

(§) = shows that the parameter is visible only in certain programming conditions; see the explanation of the parameter for the details.

(\*) = shows that with an approved instrument the parameter could be not visible or not enterable; see the explanation of the parameter for further details.

- 1) Enter in the SET-UP ENVIRONMENT of the scale (when turned on, press for an instant the TARE key while the firmware version is displayed ).
- 2) **Select the type of application:**  
Enter in the "TYPE" step and select the "ind. Ch" parameter.
- 3) **Select the number of the connected cells**

Select number of scales (in other words, the number of channels, from 1 to 4) connected to the indicator:

SEtUP→COnF iG→nChAn→ 1..4 and press **PRINT**.

4) **Select the cell to be calibrated**

Select the scale to be calibrated (in other words the channel number, from 1 to 4):

SEtUP→COnF iG→ChAn→ 1..4 and press **PRINT**.

5) Select the step SEtUP→COnF iG→CAL iB and press **PRINT**.

6) **Minimum Division**

Select the "d iV" step and press **PRINT**;

Set the scale's minimum division or the first range in case of dual range and press **PRINT** (selectable values: 1, 2, 5, 10, 20, 50).

**Note:** the settable division refers to the FIRST RANGE. With the second range the following division is set. For example, by setting diV=2, the second range will have diV=5

(!) 1

7) **Number of Decimal digits**

Select the "dEC d" step and press **PRINT**;

The selectable values are 1.0 (one decimal), 1.00 (two decimals), 1.000 (three decimals), 100000 (no decimal); confirm with **PRINT**.

(!) 1.000

8) **Unit of Measure**

Select the "U. M." and press **PRINT**.

Set the unit of measure (G, Lb, t, HG) and press **PRINT**.

(!) HG

9) **Setting Total Capacity or 1st Range**

Select the "rAnGE 1" step and press **PRINT**;

Set the total capacity of the scale or the first range in case of multirange functioning.

**The keys take on the following functionalities:**

**ZERO** = Decreases the selected digit (blinking).

**TARE** = Increases the selected digit (blinking).

**MODE** = Selects the digit to be modified (blinking), from left to right.

**C** = Quickly zeros the displayed value.

10) **Setting of the 2nd Range capacity**

Select the "rAnGE 2" step (only in case of dual range scale) and press **PRINT**;

Set the capacity of the second range and press **PRINT**.

11) Select the "CAL iB. P" step and press **PRINT**.

12) Select the "nEP" step and press **PRINT**.

13) **Nr. of Calibration points**

Set the number of points with the **ZERO** or **TARE** keys on which one wants to make the calibration (from 1 to 3, with 1 one will make the zero point and a weight point) and press **PRINT**.

14) **Acquisition of Scale Zero**

Select the "EP" step (scale zero point): unload the scale and wait a few seconds; then press **PRINT**.

15) **Setting of 1st Sample Weight**

Select the "ddt 1" step (setting of first sample weight); press **PRINT**, enter the weight value and confirm with **PRINT**.

16) **Acquisition of 1st Sample Weight**

Select the "EP" step (acquisition of first sample weight): put the weight on the scale, wait a few seconds and press **PRINT**.

17) **If a calibration point had been set**, once the weight acquisition has been made, the display shows for an instant the value of the internal divisions and then the "nEP" step (or "EQUAL" for the calibration procedure for dependent channels mode, see the next paragraph).

18) **If there are more calibration points, repeat the operations for the points "ddt 2", "EP 2", "ddt 3", "EP 3"**. Once the weight acquisition is made, the display shows for an instant the value of the internal divisions and then the "nEP" step (or "EQUAL" for the calibration procedure for dependent channels mode, see the next paragraph).

19) **If a single scale is connected to the instrument (nChAn = 1) >> go to point 20)**

If there are various scales connected to the instrument ( $nChAn > 1$ ) >> Repeat the calibration procedure for each scale, starting from point 3) in order to select the scale to be calibrated (go through again the steps from 3) >> 16).

20) **Saving the Calibration**

Once the calibration has been made of all the necessary points, press many times the **C - ON/OFF** key until the indicator shows *SRULEP* in the display: confirm with **PRINT** to store and return to weighing.

**N.B.:** the calibration points must be in increasing order (point 1 < point 2 < point 3).

**5.2 Calibration procedure for DEPENDENT CHANNELS MODE (could eventually be digitally equalized)**

**Premise:** this procedure is to be followed in case one has to calibrate a scale having 2, 3 or 4 load cells in the "dEP. CH" functioning mode, (see the parameter: C – Type of application) and wants to equalize directly from the indicator, without using the external junction boxes.

In this case one should connect each single cell to one of the available channels of the instrument.

**Note:** it is always better to carry out the **equalization procedure** (steps from 4 to 9), but it isn't compulsory (in some applications, it can not be done).

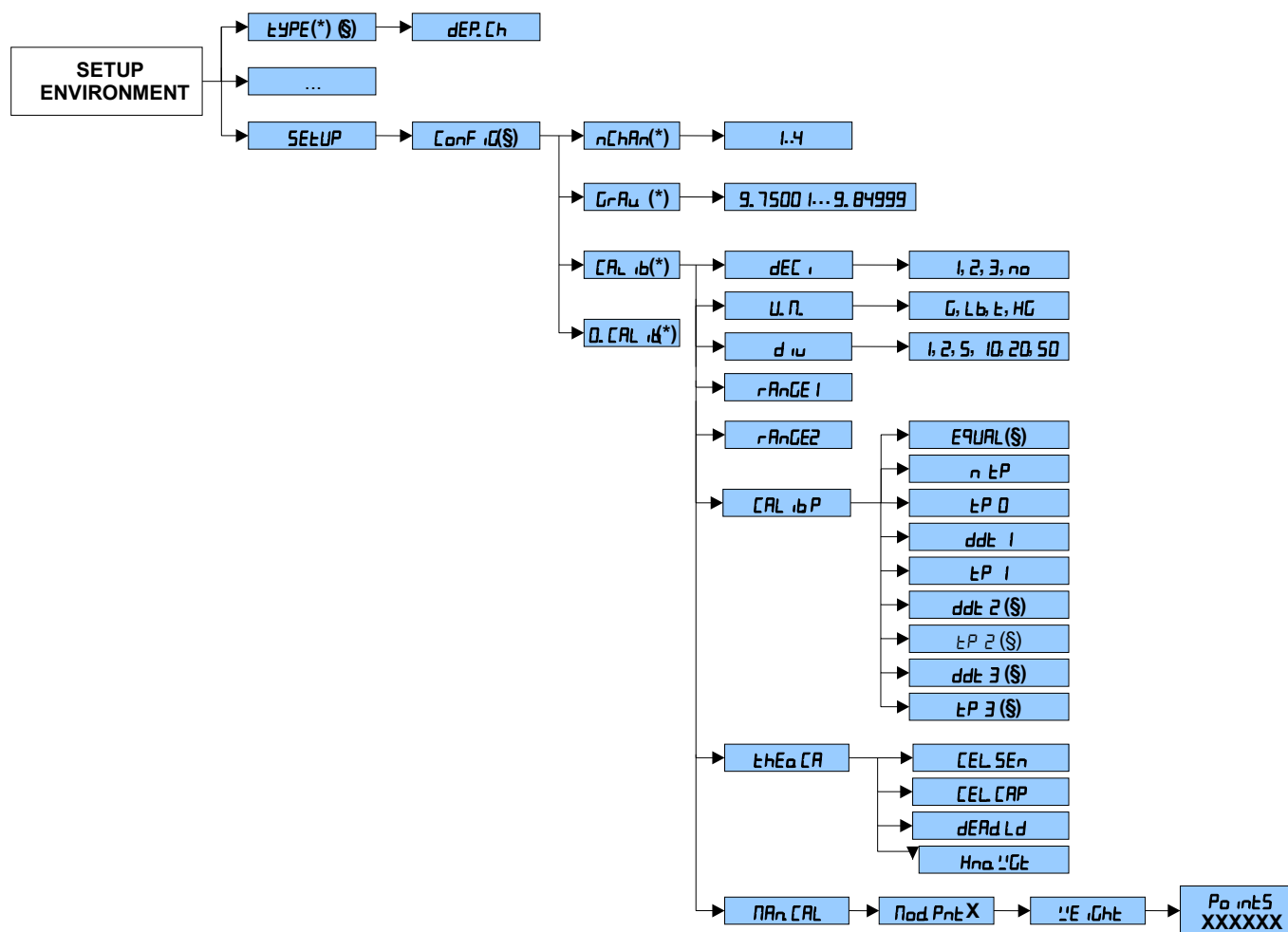

(§) = indicates that the parameter is visible only in certain programming conditions; see the explanation of the parameter itself for the details.

(\*) = indicates that with an approved instrument the parameter can be not visible or read only; see the explanation of the parameter itself for the details

- 1) Enter in the SET-UP ENVIRONMENT of the indicator (when turned on, press for an instant the TARE key while the firmware version).
- 2) **Select the type of application:**  
Enter in the "TYPE" step and select the "dEP. CH" parameter.
- 3) **Select the number of connected cells**  
Select the number of cells (in other words, the number of the channels, from 2 to 4) in the **SETUP** → **CONF. iC** → **nChan** step and press **ENTER/PRINT**.

4) Repeat the passages from 4) to 10) described previously in the section "Calibration procedure for the INDEPENDENT CHANNELS and "TRANSM" modes"

If one does not want to carry out the equalization proceed with point 11).

**Cell Equalization procedure:**

- 5) Select the "E9 L" step and press ENTER/PRINT: the display shows "RESET"= confirm with **ENTER** to clear the present equalization and proceed to the **equalization of the cells**; by pressing C one exits the equalization.
- 6) Select "E9 0" step (equalization of zero): unload the weighing system and press the **PRINT** key.
- 7) Select "E9 1" step (equalization of the first cell): put a calibration weight on the cell connected to input 1 of the indicator and press the **PRINT** key.
- 8) Select "E9 2" step (equalization of the second cell): put the **same calibration weight** on the cell connected to input 2 of the indicator and press the **PRINT** key.
- 9) **If nChan > 2:**  
Select "E9 3" step (equalization of the third cell): put the **same calibration weight** on the cell connected to input 3 of the indicator and press the **PRINT** key.  
**If nChan > 3:** Select E9 4 step (equalization of the fourth cell): put the **same calibration weight** on the cell connected to input 4 of the indicator and press the **PRINT** key.
- 10) When the equalization is finished the message E9 0H appears and one exits the equalization submenu.
- 11) Select the "nLP" step and press **PRINT**.
- 12) **Nr. of Calibration points**  
Set the number of points with the **ZERO** or **TARE** keys on which one wants to make the calibration (from 1 to 3, with 1 one will make the zero point and a weight point) and press **PRINT**.
- 13) **Acquisition of Scale Zero**  
Select the "tP0" step (scale zero point): unload the scale and wait a few seconds; then press **PRINT**: if the equalization of the channels has not been made the no E9P message appears: press the ENTER/PRINT key to proceed anyways with the acquisition of the weight or the **C - ON/OFF** key to exit the step.
- 14) Repeat the points from 15) to 17) described previously in the "Calibration procedure for the INDEPENDENT CHANNELS and "TRANSM" modes".
- 15) **Saving the Calibration**  
When the calibration has been made of all the necessary points, press various times the **C - ON/OFF** key until the indicator shows SALP in the display: confirm with **PRINT** to store and return to weighing.

**Note:** after the cell equalization, is necessary to execute the calibration procedure

### **5.3 IN CASE THE ZONE OF USE IS DIFFERENT FROM THE CALIBRATION ZONE ONE SHOULD:**

- 1) Enter the SET-UP ENVIRONMENT of the scale (when turned on, press for an instant the TARE key while the firmware version is displayed ).
- 2) Enter the step **SEtUP**→**ConF** ,**G**→**GrAV.** and set the gravity acceleration value for the CALIBRATION ZONE.
- 3) Make the calibration as described previously.
- 4) Save and exit the SET-UP ENVIRONMENT (press various times the **C - ON/OFF** key until the indicator shows "SRUP" in the display and confirm with PRINT).
- 5) Enter the SET-UP ENVIRONMENT of the scale and enter the step **SEtUP**→**ConFiG**→**GrAV.** and set the gravity acceleration value for the ZONE OF USER.
- 6) Save and exit from the SET-UP ENVIRONMENT.
- 7) The weight error caused by a different gravitational value between the calibration zone and the zone of use is automatically corrected.

**NOTE:** with Approved Instrument, upon start-up the display shows the gravitational acceleration value of the ZONE OF USE.

### **5.4 QUICK CALIBRATION OF ZERO**

Useful for calibrating just the ZERO point when a permanent TARE weight is added to the scale (for example a roller unit).

- 1) Enter in the SET-UP ENVIRONMENT of the scale (upon start-up, press for an instant the TARE key while the firmware version is displayed ).
- 2) Enter the step **SEtUP**→**ConF** ,**G**→**0. CAL** ,**b** and press PRINT (the display shows "CAL. 0").
- 3) **Tare Acquisition**  
Put the tare on the scale and press PRINT to confirm the operation.
- 4) **Saving the Calibration**  
Once the zero calibration is made, press various times the **C - ON/OFF** key until the indicator shows "SRUP" in the display: confirm with PRINT to store and return to weighing.

### **5.5 THEORETICAL CALIBRATION**

**Premise:** it's possible to use this procedure if one does not have a sample weight available for carrying out a real calibration.

- 1) Follow the steps described in par. 4.1 up to point 10) (independent channels), otherwise follow the steps described in par. 4.2 up to point 4) (dependent channels)
- 2) Select the "THEO. CAL" step and press **PRINT**
- 3) **Setting cell sensitivity in mV/V**  
Select the **CEL. SEN** step; press **PRINT**, enter the cell sensitivity in mV/V (up to 99.9999 mV/V) and confirm with **PRINT**.  
In case of various connected cells through the junction box, enter the average of the value; in case of dependent channels, enter the sum of the value.
- 4) **Setting cell capacity**  
Select the **CEL. CAP** step; press **PRINT**, enter the cell capacity (the unit of measure is the one configured for the scale, up to 999999) and confirm with **PRINT**. In case of connection of multiple load cells with junction box, the value set in this step must be equal to the sum of the flow load cells. This procedure is valid for both dependent channel system and for independent channel system.
- 5) **Setting pre-load weight**  
Select the **DEAD. LD** step; press **PRINT**, enter the weight of the structure bearing on the load cells. The first character indicates the sign: '0' indicates a positive value, '-' indicates a negative value. The sign is changed by positioning on the first digit and press on the up arrow / down arrow keys:  
with 3 decimals: from -9.9999 to +9.9999  
with 2 decimals: from -99.999 to +99.999  
with 1 decimal: from -999.99 to +999.99  
with 0 decimals: from -9999.9 to +9999.9  
Confirm with the **PRINT** key.  
**Note:** enter 000000 if one does not know this value.

## 6) Acquisition of a known weight

Select the *Known Weight* step and press **PRINT**; the "*Set Up*" message appears; enter the known value (value included between 0 and the scale capacity, the unit of measure is the one set for the scale) and press

**Note:** by setting 0 one acquires the weight of the bearing structure on the cells.

In case of unstable weight the "*Error*" message will appear for a second, the display will show *Store* message, press **PRINT** to save it, or press **C** key to next confirmation, and then one will be asked if one wants to repeat the operation ("*Repeat*" message). In this case press **PRINT** to repeat the operation.

Once the procedure is finished, press the **C** key to exit the calibration; one will be asked whether to apply the new calibration ("*Apply*"). Press **PRINT** to confirm, or **C** to cancel.

**Note:** once the calibration is confirmed, the indicator sets the capacity of the cells (*Cell Cap* step) equal to the scale capacity; consequently the values of the other steps are automatically recalculated.

If there are various scales, repeat the previous passages by selecting the desired channel (*SETUP* → *CONF* → *IG* → *Chan* → 1..4).

## 5.6 MANUAL CALIBRATION OF A DEFINED WEIGHT

It is useful to manually recalibrate the point of a defined weight except 0 weight when the user knows the number of points of the converter and wants to recalibrate the scale.

- 1) Enter in the SET-UP environment of the scale (when turned on, press for an instant the TARE key while the firmware version is displayed).
- 2) Enter in the *SETUP* → *CONF* → *IG* → *CAL* → *ib* → *PAR. CAL* (§) step and press ENTER/PRINT key (the display shows *Mod. Point*).
- 3) Enter the number of the sample weight to be manually recalibrated (between 0 and 3) and press ENTER/PRINT key to confirm the value; the *Weight* message is displayed for an instant, then enter the weight value of the selected sample weight and confirm by pressing ENTER/PRINT.
- 4) The display shows *Points* for an instant, then enter the number of converter points and confirm by pressing ENTER/PRINT. Once this value has been acquired, the indicator exits from the *PAR. CAL* step; then press many times the C key until the display shows *SAVE*: confirm with ENTER/PRINT to store and return to weighing.

(§) The step is displayed only if the number of points of calibration has been entered.

## 6. DISPLAY OF THE GRAVITY ACCELERATION AND CORRECTION OF THE WEIGHING ERROR due to the different gravity acceleration between the calibration and the utilization zone.

This instrument conforms to the laws currently in force regarding non-automatic weighing instruments.

Such g-sensitive instruments are influenced by the gravitational acceleration value "g" of the utilisation zone.

Therefore a special programme has been created to compensate for any differences in the gravitational attraction between the place where the weighing machine is calibrated and the place of utilisation, eliminating in this way the error entered on the weight.

During configuration the "g" values relative to the utilization zone and to the zone of calibration are entered at a certain programming step which eliminates the weight error introduced by the different gravitational attraction value.

When turned on, by pressing the **ZERO** key, the instrument displays, after the name and the installed software version, the "g" value relative to the gravitational zone of use for a few seconds.

## 7. SERIAL OUTPUTS

The instrument has two bidirectional serial outputs, which have the output in ASCII code compatible with the majority of printers, remote displays, PCs and other devices.

The transmission of data through the serial ports can be configured in different ways, according to the setting of the "PC SEL", "PC Mode" and "Pr. Mode" steps in the SET-UP environment.

Refer to the paragraph "SERIAL PORT TRANSMISSION MODES" for the functioning specifics.

### 7.1 RS485 (SCT-100 / SCT-100AN) SERIAL PORT

It is bi-directional (half duplex) and uses an R485 for transmitting data.

It is mainly used to connect computers, PLCs, additional remote displays.

The transmission speed may be selected in the set up among these: 1200, 2400, 4800, 9600, 19200, 38400, 57600, 115200 Baud (bit/sec.).

Below is the RS485 connection of the indicator:

Meaning	Indicator Serial line
TX/+RX+	22 A(+)
TX-/RX-	23 B(-)

On the same RS 485 line it's possible to connect up to 32 devices, among indicators, digital load cells, 485/232 signal converter.

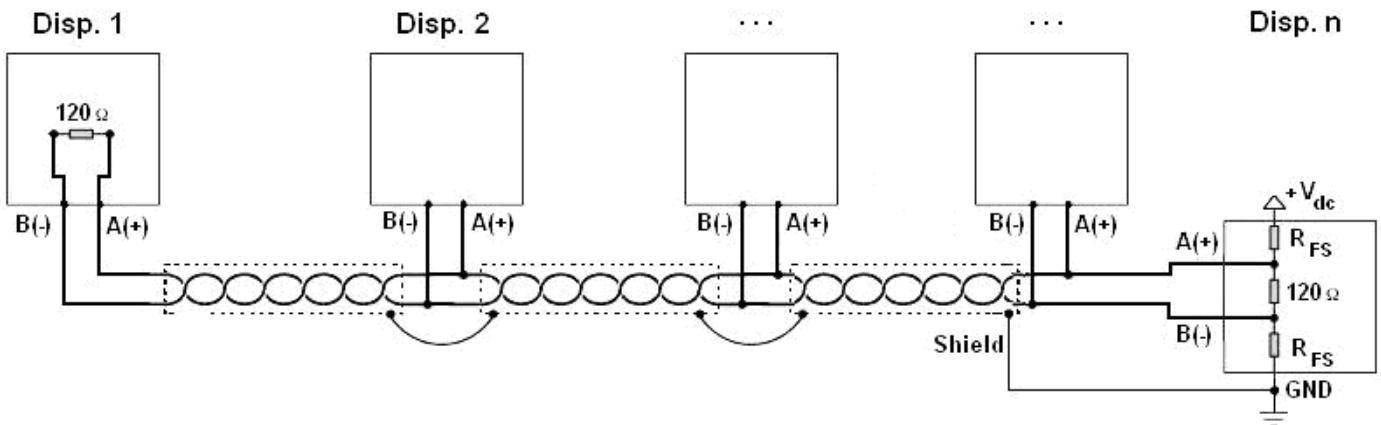

Figure 1: electrical diagram of RS485 connections.

- Use a **STP** (Shielded Twisted Pair) cable in order to make the connection (twisted and shielded pair/s with single shielding for each pair through aluminium band and total shielding through external sheathing).
- The maximum reachable length from the line with the use of the appropriate cable for RS 485 connections, the twisted 2x24 AWG duplex cable, shielded with external sheathing + aluminium band, is of about 1200 meters (see section 1.1.3)
- With very long cables, the cable capacity (normally near 50pF/m) starts being a dominant factor in the power consumption and increases with the increase of speed.

This implies that **the maximum distance can't be covered with the maximum possible speed**. For an approximate value, one can consult the following table:

Baud rate	Total capacity of the cable (pF)
1200	400000
2400	200000
4800	100000
9600	50000
19200	25000
38400	12000
57600	8000
115200	4000

As a general rule, if one has any doubts, it is always preferable to **choose the cable with a greater section**.

- Verify that the grounding satisfies the requirements of section 1.2. Especially, all the digital masses, as well as the analogue masses, and the power circuits, must be connected to the grounding bar and this last one must be connected to the grounding pole.
- The shielding can be connected into a single point of the entire network (as shown in Figure 1) or both its ends, however it's important that **all the masses have the same potential**, in order to avoid the forming of current rings.
- On the RS485 network normally one connects 2 **termination resistances** equal to the characteristic impedance of the cable (the typical value is 120 Ω, see Figure 1), **ONLY** on the 2 devices **which are at the 2 ends of the cable**. The terminal resistance is not supplied with the ports of the indicator.
- The difference of potential between the A(+) and B(-) terminals in rest conditions (for example with instrument in set-up phase), **must be of at least 0,2 V**.

To create a resistive divider which maintains this difference of potential also when all the transmitters are disabled, inert in the RS485 port of the indicator where there are the termination resistances, the **polarisation** or **fail-safe resistance** ( $R_{FS}$  in Figure 1). The value of these resistances is between 390 Ω and 2,2 kΩ.

**NOTE:** in particular, the value of each of these resistances must be greater than the value calculable through the formula:

$$R_{FS} = \frac{R_{eq}}{2} \times \left( \frac{V_{dc}}{0,2} - 1 \right)$$

in which:

- $V_{dc}$  is the power supply voltage of the line
- $R_{eq}$  is the overall resistance to the A(+) a B(-) heads, supplied by the parallel of the 2 termination resistances and all the input resistances of the devices connected to the bus.

FOR EXAMPLE:

Presuming that a connection has 120 Ω as termination resistance and 32 connected devices, each having an input impedance of 12 kΩ. The  $V_{dc}$  power supply is 5 V.

One calculates  $R_{eq}$ , equal to about 52 Ω, and  $R_{FS}$  which must be at least equal to 624 Ω.

- **The connection between the indicator and the digital load cells is made with RS485 protocol in the COM3 configured as CoMAuX.** The indicator can be connected with up to 16 digital load cells. It's possible to connect the indicator to digital load cells with 485 4-wire protocol through 422/232 converter. In this case one is required to connect the double TX of RS422 cable to TX+ and TX- converter's pins and the double RX of RS422 cable to RX+ and RX- converter's pins
- In case of connection with non RLWS devices, there may be different ways of line marking: generally one presumes that the A/B indication corresponds to the +/- and HI/LO markings, but this is not always true. Therefore, if the device does not function, one should try inverting the connections even if everything seems to be correct.
- For the correct functioning of the digital load cells, one should, in any case respect all the rules given in the specific manuals.

Please find below the RS232 connection for the SCT-100 configured as repeater:

TRANSMITTER		SCT-100
GND		GND
TX		RX

## 7.2 RS232 or COM2 SERIAL PORT

It is bi-directional (full duplex) and uses an RS232 for transmitting data; it is mainly used to connect to printers, computers and PLCs. The transmission speed may be selected in the set up among these: 1200, 2400, 4800, 9600, 19200, 38400, 57600, 115200 Baud.

### Connections from LP542S, DP24, DP190 printer to indicator:

	DP24/LP542S 9pin (female)	DP190 Terminal Board	INDICATOR	CABLE STANDARD
GND	5	GND	GND	Grey
CTS	8	BU	RX	Brown
RX	3	RX	TX	Pink

### Please find below the connection between the TPR printer and the indicator:

TPR Terminal board	INDICATOR STANDARD CABLE
GND	GND Black
RTS	RX Yellow
RX	TX Grey
	Blue (not connected)

### Please find below the connection in RS232 between the PC and the indicator:

	PC 9pin (male)	PC 25pin (male)	INDICATOR	STANDARD CABLE
GND	5	7	GND	Grey
TX	3	2	RX	Yellow
RX	2	3	TX	Pink

### Please find below the connection in RS232 for the SCT-100 configured as a repeater:

TRANSMITTER	SCT-100
GND	GND 17
TX	RX 16

### 7.3 PROFIBUS PORT (SCT-100PB)

When is setted this protocol in the *SETUP→SERIAL→CONF. PC→PCMODE* step, it is request to insert the profibus address, after the display shown *CONF. PC*, confirm and select “**YES**” to enable the compatibility of the profibus module communication with “**GSD.V.1**” file. Leaving it on “**NO**” the profibus communications is compatible with “**GSD.V.2**” file.

It is bidirectional and it is mainly used for connections to the PLC.

The transmission speed (baud rate) and the format of the serial word, in case of Profibus transmission, are not modifiable in the SETUP ENVIRONMENT, but by default are set at:

- **Baud Rate** (or transmission speed): **9600 bit / sec**
- **Format of the Data** (or format of the serial word): **n - 8 - 1** (no parity – 8 data bits – 1 stop bit)

**Below is the PROFIBUS connection of the indicator:**

Indicator	Meaning
Profibus port	
At	to
3 B-LINE	3 B(-)
5 GND BUS	5 GND
6 +5V BUS	6 +5V
8 A-LINE	8 A(+)

**NOTE:** The PROFIBUS port supports only the "PROFIBUS" transmission mode available only for the PC port (see *SETUP→SERIAL→CONF. PC→PCMODE* step).

### 7.4 SERIAL PORT TRANSMISSION MODES

#### 7.4.1 PC PORT SELECTION

It's possible to select the serial port to be used as a PC port and therefore, invert the serial ports.

This setting is made in the *SETUP→SERIAL→PC SEL* step.

By selecting the **485/PROFIBUS** serial port as PC PORT, the **232** serial line is set as PRN PORT.

By selecting the **232** serial port as PC PORT, the **485** serial line is set as PRN PORT or, in the case of the **SCT-100PB**, the **PROFIBUS** port is not managed.

## 7.4.2 PC PORT

Please find below the various selectable serial weight transmission modes of the PC serial port through the corresponding "PC Mode" step of the SET-UP environment.

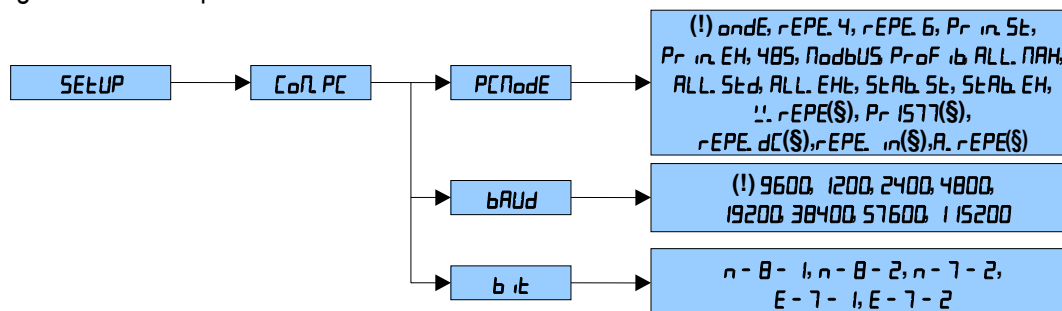

### - TRANSMISSION REQUESTED FROM AN EXTERNAL DEVICE (''onDE'' parameter)

In this case the indicator waits for a command before transmitting (see the section "SERIAL COMMANDS FORMAT").

With Baud rate at 9600, through the READ command, it is possible to make up to 10-11 requests per second, while with Baud rate at 115200 one can arrive at 16.

The transmission works with weight <, =, > 0 with approved or unapproved instrument.

### • 4 – 6 DIGIT REMOTE DISPLAY TRANSMISSION (''rEPE. 4'' and ''rEPE. 6'' parameter and F. Mode → FUNC step not set on rEPE)

If one has selected a functioning mode different than rEPE in the F. Mode → FUNC step, The weight displaying takes place both in the indicator as well as in a weight repeater of 4 or 6 digits, (normally the capacity will be properly set up for a correct displaying).

**NOTE:** When either transmission mode is selected, the relative serial output is automatically set to 4800, N – 8 – 1. In any case it's possible to set it differently.

Independently from the set transmission speed one can obtain up to 6 transmissions per second.

#### • TRANSMISSION WHEN THE PRINT KEY IS PRESSED (''Pr in Std'', ''Pr inEH'' parameter)

The instrument communicates the weight data through the serial port when the PRINT key is pressed (except for in the TOTALIZER mode where one should press the MODE key).

For non approved instruments:

The transmission takes place if the weight is stable and the net weight is > 0.

Reenabling the transmission depends on how the ''rEPE'' step has been set in the SET-UP environment (passing by zero of the NET weight, weight instability or always).

For approved instruments:

The transmission takes place if the weight is stable and the net weight is > 20 divisions.

Reenabling the transmission depends on how the ''rEPE'' step has been set in the SET-UP environment (passing by zero of the NET weight, weight instability or always).

#### NOTES:

- In the TOTALISER functioning mode, the transmission on the PC port takes place upon the pressing of the **MODE** key.
- The data is transmitted using the standard string ( Pr in. St) or the extended string (or multiscale string in the TRANSM mode) ( Pr in. EH); see the paragraph "TRANSMISSION PROTOCOLS" for the description of the 3 strings.
- The transmission is confirmed by the indication of ''Tr AnSt'' on the display.

#### • TRANSMISSION IN RS 485 SERIAL MODE (''485'' parameter)

The protocol is the same as the transmission upon request ( onDE parameter), except that the instrument responds only if its machine code is the one requested (before the request the machine code must be put, I.E. 00READ<CRLF>).

If a broadcast address command (99) is received no answer is given. If the command is correct it is executed anyways.

**Note:** In case of a MASTER/SLAVE connection, connect the SLAVE indicator to the PC and configure ALL. Std parameter (SETUP → Ser. AL → CONF. PC → PC Mode)

- **TRANSMISSION IN MODBUS MODE** ("ModBUS" parameter)

→ See the "MODBUS transmission" appendix, to be requested from the reseller.

- **TRANSMISSION IN PROFIBUS MODE** ("PROF ib" parameter)

→ See the "PROFIBUS transmission" appendix, to be requested from the reseller.

- **CONTINUOUS TRANSMISSION** ("ALL.Std" "ALL.EHt" and "ALL.PAH" parameter)

This mode is used for interfacing to the PC, remote displays and other devices which request a constant updating of the data independently from the weight stability.

The instrument transmits data with each converter read operation:

- With Baud rate at 9600 one can obtain up to 10 transmissions per second.
- With Baud rate at 115200 one can obtain up to 16 transmissions per second for the PC port, 12 for the PRINTER port.

The transmission works with weight <, =, > 0 with approved or unapproved instrument.

The data is transmitted using the standard string ( ALL.Std) or the extended string (or multiscale string in the TRANSM mode) ( ALL.EHt); see the paragraph "TRANSMISSION PROTOCOLS" for the description of the 3 strings.

The ALL.PAH transmission protocol is advisable for applications in which a high frequency of transmissions is requested.

(up to 250TX/sec. with baud rate equal to 115200); the weight is transmitted in hexadecimal format (for example: 03E8= 1000g), without decimal point.

NOTE: The data transmission frequency increases or lessens depending on the frequency of the configured filter.

To obtain 250TX/sec one should configure the filter F.F.400 (SETUP → CONF → PARAN. → STAB IL).

- **TRANSMISSION ON STABILITY** ("STAB.St" and "STAB.EH" parameter)

Each time a weight on the scale becomes stable, a communication string is transmitted on the PC serial port.

For non approved instruments:

- The transmission takes place if the weight is stable and the net weight is > 10 divisions.
- Reenabling the transmission depends on how the "RESET" step has been set in the SET-UP environment (passage by zero of the NET weight or instability of the NET weight of 10 divisions; by choosing "ALWAYS" it works upon instability).

For approved instruments:

- The transmission takes place if the weight is stable and the net weight is > 20 divisions.
- Reenabling the transmission depends on how the "RESET" step has been set in the SET-UP environment (passage by zero of the NET weight or instability of the NET weight of 20 divisions; by choosing "ALWAYS" it works upon instability).

The data is transmitted using the standard string ( STAB.St) or the extended string(or multiscale string in the TRANSM mode) ( STAB.EH); see the paragraph "TRANSMISSION PROTOCOLS for the description of the 3 strings.

- **RECEPTION OF THE REPE.6 STRING** ("REPE.6" parameter and F. ModE → FUNC step set on REPE)

If an instrument is connected which transmits the data with "REPE.6" protocol, the indicator repeats the data of the display and the indication leds of the connected instrument. If one enables the 485 address in the SETUP → SER → CONF → PC → Add. En step, the instrument repeats only if its machine code is the one requested (one must put the machine code before the string). The instrument repeats also if a command with broadcast address is received (99).

**NOTE:** It is advisable to have a maximum number of receptions per second equal to 10.

(§): This parameter there is only in the MASTER firmware

- **RECEPTION OF THE rEPE.dC STRING** ('rEPE.dC' parameter and F. ПодЕ → FUnC step set on rEPE)

If an instrument is connected which transmits the data with "COMPOSIT PROTOCOL," the indicator repeats the received data.

(§): This parameter there is only in the MASTER firmware

- **RECEPTION OF THE rEPE.in STRING** ('rEPE.in' parameter and F. ПодЕ → FUnC step set on rEPE)

If it is connected to an instrument that transmits the data continuously, the indicator repeats the received data. Is not requested any configuration.

(§): This parameter there is only in the MASTER firmware

- **RECEPTION OF THE A.rEPE STRING** (A.rEPE parameter and F. ПодЕ → FUnC step set on rEPE)

If it is connected to an instrument that transmit the ASCII string, the indicator will show that string until CR or only the first six characters (in case the string be longer).

Received data from MASTER instrument persists on the screen for maximum 500 ms.

(§): This parameter there is only in the MASTER firmware

- **RECEPTION OF THE STRING FROM REMOTE SCALE** ('rEPE' parameter and F. ПодЕ → FUnC step set on rEPE)

If an instrument is connected which transmits the data in continuous mode, the indicator repeats the transmitted net weight.

**NOTE:** It is advisable to have a maximum number of receptions per second equal to 10.

(§): This parameter there is only in the MASTER firmware

- **RECEPTION OF THE PR 1577 STRING** ('Pr1577' parameter and F. ПодЕ → FUnC step set on rEPE)

If an instrument is connected which transmits the data with "Pr1577" protocol, the indicator repeats the data of the display and the indication leds of the connected instrument.

(§): This parameter there is only in the MASTER firmware

### 7.4.3 PRN PORT

Please find below the various selectable serial weight transmission modes of the PRN serial port through the corresponding 'Pr. ПодЕ' step of the SET-UP environment.

- **TRANSMISSION TO PRINTER** ('LPr' and 'LP542' parameter): requests the use of the print key on the indicator (prints upon request of the operator). The print command is inhibited if the weight is in motion and in all other circumstances in which the data is not valid (see "PRINTING" section, **USER MAN.REF.**).
- **CONTINUOUS TRANSMISSION** ('ALL.Std' and 'ALL.EHt' parameter): see the 'ALL.Std' and 'ALL.EHt' modes of the PC port.
- **TRANSMISSION OF THE PC STRING UPON PRESSURE OF THE PRINT KEY** ('PrPC.St' 'PrPC.EH' and 'PrPC.HH' parameter): see the 'Pr in.St' or 'Pr in.EH' mode of the PC port.
- **4 – 6 DIGIT REMOTE DISPLAY TRANSMISSION** ('rEPE.4' and 'rEPE.5' parameter): see the 'rEPE.4' and 'rEPE.5' mode of the PC port.

**NOTE:** In the multiscale repeater functioning mode (see section "MULTISCALE REPEATER (ПАСЕр). **USER MAN.REF.**) only the transmission modes to the printer and the 'rEPE.4' and 'rEPE.5' transmission mode are enabled for the printer port.

**THE CONNECTION AND THE SOFTWARE CONFIGURATION OF THE SERIAL OUTPUTS MUST BE CARRIED OUT BY TECHNICAL PERSONNEL WHO KNOW THE PROCEDURES ON THE BASIS OF THE NEEDS OF THE USER.**

## 7.5 SERIAL COMMANDS FORMAT

LEGEND	
[CC] o <II>	instrument code, e.g. 00 (only with RS485 protocol)
<CR LF>	Carriage Return + Line Feed (ASCII characters 13 and 10)
<ESC>	ASCII character ASCII 27
<STX>	ASCII character ASCII 02
B	space character, ASCII 32.

### SERIAL ERRORS

Upon each serial command received the instrument transmits a string containing the answer (see the command description) or it transmits one of the following indications:

OK<CR LF>	it is shown when a correct command is transmitted from the PC to the indicator. The OK answer does not imply that the instrument executes the zero.
ERR01<CR LF>	it is shown when a correct command is transmitted from the PC to the indicator however it is followed by letters inserted involuntarily (I.E.: READF, TARES...).
ERR02<CR LF>	it is shown when a correct command is transmitted from the PC to the indicator, but containing wrong data.
ERR03<CR LF>	it is shown when a non allowed command is transmitted. It may be a command not used in the selected functioning mode or the command reaches the indicator in the instant in which the keyboard buffer is already occupied by another command
ERR04<CR LF>	it is shown when an inexistent command is transmitted.

**NOTE:** The instrument doesn't transmit any indication with the short commands, like the ones made up of only one letter and then the possible parameter.

### Version reading command

[CC]VER<CR LF>

Instrument response:

[CC]VER,vv,DGT**bbbb**<CR LF>

in which:

vv is the firmware version

**b** space character, ascii decimal 32 character.

### Extended weight read command

[CC]REXT<CR LF>

Instrument response in the V mode or in the "dEP. Ch" mode: EXTENDED STRING (see paragraph "EXTENDED STRING").

Instrument response in the "Er-Rn5F" mode: MULTISCALE STRING (see paragraph "MULTISCALE STRING").

### **NOTES:**

- If the instrument is in the "ind. Ch" mode (scale with independent channels) or in the "dEP. Ch" mode (scale with dependent channels and digitally equalized) the weight value is read relative to the active channel; to read the values of the other channels (if configured) one has to switch each time onto the desired channel (see also *CGCH channel switching command*).
- If the instrument is in the "Er-Rn5F" mode (scale with independent channels) it is possible to read simultaneously the values for all the configured channels

### Reading command of the extended weight with Average Piece Weight (APW)

[CC]REXTA<CR LF>

Instrument response in the "ind. Ch" or in the "dEP. Ch" mode: EXTENDED STRING (see paragraph "EXTENDED STRING").

Instrument response in the ''*IND.CH*'' mode: MULTISCALE STRING (see paragraph "MULTISCALE STRING").

#### **NOTES:**

- If the instrument is in the ''*IND.CH*'' mode (scale with independent channels) or in the ''*DEP.CH*'' mode (scale with dependent channels and digitally equalized) the weight value is read relative to the active channel; to read the values of the other channels (if configured) one has to switch each time onto the desired channel (see also *CGCH channel switching command*).
- If the instrument is in the ''*IND.CH*'' (scale with independent channels) mode it is possible to read simultaneously the values for all the configured channels.

#### **Extended weight read command with date and hour**

[CC]REXD<CR LF>

Instrument response in the ''*IND.CH*'' or in the ''*DEP.CH*'' mode: EXTENDED STRING (see paragraph "EXTENDED STRING").

Instrument response in the ''*IND.CH*'' mode: MULTISCALE STRING (see paragraph "MULTISCALE STRING").

#### **Weight read command**

[CC]READ<CR LF>

Instrument response: STANDARD STRING (see paragraph "STANDARD STRING").

#### **Weight reading command with sensitivity times 10**

[CC]GR10<CR LF>

Instrument response: STANDARD STRING (see paragraph "STANDARD STRING").

#### **Reading command of micro volts relative to the weight**

[CC]MVOL<CR LF>

Instrument response in ''*IND.CH*'' mode: STANDARD STRING (see paragraph "STANDARD STRING").

Response of the instrument in ''*IND.CH*'' and ''*DEP.CH*'' mode: MULTISCALE STRING (see section "MULTISCALE STRING").

#### **NOTES:**

- If the instrument is in the ''*IND.CH*'' mode (scale with independent channels) the voltage value is read relative to the active channel; to read the values of the other channels (if configured) one has to switch each time onto the desired channel (see also *CGCH channel switching command*).
- If the instrument is in the ''*IND.CH*'' (scale with independent channels) or in the ''*DEP.CH*'' mode (scale with dependent channels and digitally equalized) mode it is possible to read simultaneously the values for all the configured channels

#### **Reading command of converter points relative to the weight**

[CC]RAZF<CR LF>

Instrument response in ''*IND.CH*'' mode: STANDARD STRING (see paragraph "STANDARD STRING").

Response of the instrument in ''*IND.CH*'' and ''*DEP.CH*'' mode: MULTISCALE STRING (see section "MULTISCALE STRING").

#### **NOTES:**

- If the instrument is in the ''*IND.CH*'' mode (scale with independent channels) the voltage value is read relative to the active channel; to read the values of the other channels (if configured) one has to switch each time onto the desired channel (see also *CGCH channel switching command*).
- If the instrument is in the ''*IND.CH*'' (scale with independent channels) or in the ''*DEP.CH*'' mode (scale with dependent channels and digitally equalized) mode it is possible to read simultaneously the values for all the configured channels

#### **Tare command**

[CC]TARE<CR LF> or [CC]T<CR LF> (short command).

Instrument response: [CC]OK<CR LF> if the command has been RECEIVED; the instrument's response does not mean necessarily that the instrument executes the tare.

### **Zero command**

[CC]ZERO<CR LF> or [CC]Z<CR LF> (short command)

Instrument response: [CC]OK<CR LF> if the command has been RECEIVED; the instrument's response does not mean necessarily that the instrument executes the zero.

### **CLEAR command**

[CC]C<CR LF>; [CC]CLEAR<CR LF>

Instrument answer: [CC]OK<CR LF> if the CLEAR command has been RECEIVED, no answer for the **C - ON/OFF** command; the instrument answer does not imply that the command is executed.

The command works also inside the SET-UP ENVIRONMENT.

### **Command for Switching the Converter Channel**

[CC]CGCHN<CR LF>

Instrument answer: [CC]OK<CR LF> if the CGCH command has been RECEIVED.

In which N: number of channel on which one wants to position the instrument

### **Test Command**

[CC]ECHO<CR LF>

Instrument response: [CC]ECHO<CR LF>.

### **Print Command**

[CC]PRNT<CR LF> or [CC]P <CR LF> (short command).

Instrument answer: [CC]OK<CR LF> if the PRINT command has been received; no answer for the P command; the instrument's response does not mean necessarily that the instrument executes the printout.

### **Tare insertion command**

[CC]TMANVVVVVV<CR LF> or [CC]WVVVVV <CR LF> (short command)

in which: VVVVVV: manual tare value with the decimal point, from 1 to 6 characters; the non significant zeros can be omitted.

Instrument answer: [CC]OK<CR LF> if the TMAN command has been RECEIVED; no answer for the W command; the instrument's response does not mean necessarily that the instrument executes the tare.

### **Command for viewing temporary message on the display**

[CC]DISPNNVVVVV <CR LF>

in which: NN: is the indicator display number, standard 00 (ascii hex)

V is the message:

- if present it is shown on the NN display.
- if not present, the command interrupts the possible visualisation enabled using a previous DISP command, restoring the visualisation of the weight data.

### **NOTE**

In the case in which the display shown in the command is of the numeric type (for example the standard display 00), if in the transmitted message there are two consecutive points the message is stopped after the first of the two points. When the display is showing a message transmitted serially through the DISP command, the indicator does not display those messages usually shown in the scale status (ZERO, TARE, HOLD, ...).

Instrument response: [CC]OK<CR LF>

The message remains for the time set through the DINT command:

The ASCII characters having the decimal code greater than 31 are accepted.

### **With approved instrument:**

One needs to wait the end of the current visualisation before being able to view the next one.

### **Command for setting display visualisation interval**

[CC]DINTNNNN<CR LF>

in which: NNNN is the visualisation interval (in milliseconds), expressed in ascii hex character; for example, in order

to set a visualisation time of 2 seconds (2000 milliseconds, which converted into hex it becomes 07D0), the command becomes DINT07D0<CR><LF>.

By setting a time equal to zero, the message transmitted with the DISP command remains permanently shown on the display.

Instrument response: [CC]OK<CR LF>

**With approved instrument:**

The minimum settable time is 1 millisecond (0001HEX), and maximum settable time is 5 seconds (5000 milliseconds, 1388 HEX).

**PC confirmation command**

[CC]PCOK<CR LF>

The indicator shows on the display the "'-PCDH-'" message for about 2 seconds.

Instrument response: [CC]OK<CR LF>.

**Serial command for setting the apw (only for the counting operating mode)**

[CC]SPMUvvvvvvv <CR LF> or [CC]Xvvvvvvv<CR LF> (short command).

in which: vvvvvvvv is the apw (up to 8 characters with decimal point); maximum value: 9999.999

System response: [CC]OK<CR LF>.

For example, to set a APW of 1.55 g, the command is the SPMU1.55<CR LF> or SPMU0001.550 <CR LF> and all the various combinations adding zeros to the right or to the left but taking into consideration that the maximum length of the APW field is 8 characters.

**NOTES:**

- The APW are not accepted in the SPMU.12<CRLF> format; these must be in the SPMU0.12<CRLF> format.
- The APW are not accepted equal to zero.

**Serial command which supplies the indicator status**

[CC]STAT<CR LF>

Instrument response:

[CC]STATXX<CR LF>

in which XX is a decimal value which supplies the status of the indicator; the possible values are:

<b>XX</b>	<b>indicator status</b>
00	normal scale status
01	normal scale status in input
02	instrument in technical set-up
03	instrument in boot phase
04	instrument in rx/tx set-up phase
05	instrument in test phase of the serial ports
06	instrument in print test
07	instrument in firmware update phase
08	instrument in stand-by
09	instrument in automatic zero phase
10	instrument in change channel
11	instrument in inputs test phase

### Key pressure simulation command

[CC]KEYPXX<CR LF>

in which XX is the code of the pressed key:

- 00: ZERO key;
- 01: TARE key;
- 02: MODE key;
- 03: PRINT key;
- 04: C key
- 05: numeric 1 key;
- 06: numeric 2 key;
- 07: numeric 3 key;
- 08: numeric 4 key;
- 09: numeric 5 key;
- 0A: numeric 6 key;
- 0B: numeric 7 key;
- 0C: numeric 8 key;
- 0D: numeric 9 key;
- 0E: numeric 0 key;

Instrument response: OK<CR LF>: accepted command.

In case the simulated key has two linked functions (key briefly pressed or at length, like the TARE key), if the KEYP command is followed by the release command of the (KEYR) key within a maximum time of 1,5 seconds, the simple function will be executed (key briefly pressed); otherwise the second function will be made (key pressed at length).

### Key pressure simulation command

[CC]KEYR<CR LF>

Response: [CC]OK<CR LF>

**NOTE:** The instrument does not transmit the OK answer to the following short commands: P, Q, T, W, X, Z.

**Scale information reading:** [CC]RALL<CR LF>

Instrument answer:

SS,B,NNNNNNNUM,LLLLLLLUM,YTTTTTTTTTUM,XXXXXXXXUM,SSS,AAA,CCC,TTT,XXXXX-YYYYYY<CR LF>.

in which:

SS	UL Underload
	OL Overload
	ST Stability of the display
	US Unstability of the display
	TL Active inclination input
B	Number of platform on which the totalisation has been made.
NNNNNNNUM	Net weight with unit of measure.
LLLLLLLUM	Gross weight with unit of measure.
XXXXXXXXUM	Last net weight totalized with unit of measure
SSS	Scale status: 000 weighing 001 numeric value input 002 set-up menu
AAA	Counter of pressed keys.
CCCC	Code of last key pressed.
TTT	Counter of totalisations.
XXXXX	Last rewriting number stored in the Alibi memory.
YYYYYY	Last weigh number stored in the Alibi memory.

### **Set point command**

[CC]STPTntxxxxxyyyyyy<CR LF>

in which: n indicates the SET POINT number (1, 2)

t → **F** if the following weight value indicates the DISABLING of the outputs (OFF).

t → **O** if the following weight value indicates the ENABLING of the outputs (ON). xxxxxx and yyyyyy take on the set point value of disabling or enabling: the digits must be entered WITHOUT the decimal point, omitting the NON significant zeros.

Instrument responses: [CC]OK<CR LF> in case of syntax and correct values.

[CC]NO<CR LF> in case of correct syntax but wrong values.

### **Example of instrument with capacity 10,000 kg and division 1 g:**

Command: **STPT1F5000O6500** (Disabling first output at 5 kg and enabling at 6,5 kg)

Response: **OK**

**NOTES:** The negative response of the instrument (ERR 02), happens in the following cases:

- one of the two entered values is greater than the capacity.
- one of the two entered values has a minimum division that is inconsistent in comparison to the one set in the instrument.
- the disabling value is greater than that of enabling.

Furthermore, the transmitted values are valid until the indicator is turned off. To permanently save these on the instrument one should use the saving command (CMDSAVE) described later on. If one wants to save various set points one should set all of them and at the end transmit the saving command.

### **SET POINT saving command**

[CC]CMDSAVE<CR LF>

Response: [CC]OK<CR LF>

### **ENABLE/DISABLED KEYBOARD**

To **enable** the keyboard:

[CC]KEYEE<CR LF>

Response:[CC]OK<CR LF>

To **disable** the keyboard:

[CC]KEYED<CR LF>

Response:[CC]OK<CR LF>

## ADVANCED COMMANDS

### Input reading command:

#### Syntax

<b>Format</b>	<CC><II>INPU<N><CR LF>
<b>Parameters</b>	N = input number (expressed in hexadecimal): - 0 to simultaneously read all the inputs. - from 1 to 2 to identify the single input which one wants to read
<b>Answer</b>	<CC><II>INPUNVVVV <CR LF> In which N = input number (expressed in hexadecimal), described previously VVVV = input \ inputs status: - for the single input, V = 0000 means input not active, while V = 0001 active input, FFFF input reading error. - for all the inputs (in other words N = 0), the returned value corresponds to the hexadecimal codification of the status of the inputs
<b>Example</b>	<ESC>01INPU0 <CR LF>
<b>Result</b>	Reading of indicator's inputs' status (see the following explanation).

A bit is ascribed to each input:

Bit not managed														Board inputs SCT-100	
Bit 15	Bit 14	Bit 13	Bit 12	Bit 11	Bit 10	Bit 9	Bit 8	Bit 7	Bit 6	Bit 5	Bit 4	Bit 3	Bit 2	IN 2	IN 1
														Bit 1	Bit 0

Therefore if the INPU00003 string is received, the hexadecimal value, converted into binary, indicates that the status of the inputs is the following:

Bit not managed														Board inputs SCT-100	
Bit 15	Bit 14	Bit 13	Bit 12	Bit 11	Bit 10	Bit 9	Bit 8	Bit 7	Bit 6	Bit 5	Bit 4	Bit 3	Bit 2	IN 2	IN 1
0	0	0	0	0	0	0	0	0	0	0	0	0	0	1	0
0	0	0	0	0	0	0	0	0	0	0	0	0	0	1	1

The active inputs are therefore IN 1 and, IN 2.

#### NOTES:

- The reading command of the inputs works also in the set-up environment
- No input is ascribed to bits from 2 to 15 bits and these are fixed at zero.

## Output reading command:

### Syntax

<b>Format</b>	<CC><II>OUTS<N><CR LF>
<b>Parameters</b>	N = output number (expressed in hexadecimals): - 0 to simultaneously read all the outputs. - from 1 to 2 to identify the single input which one wants to read
<b>Answer</b>	<CC><II>OUTSNVVVV <CR LF> In which N = input number (expressed in hexadecimals), described previously VVVV = outputs status: - for the single output, V = 0000 means output not active, while V = 0001 active output, FFFF output reading error. - for all the outputs (in other words N = 0), the returned value corresponds to the hexadecimal codification of the status of the outputs
<b>Example</b>	<ESC>01OUTS0 <CR LF>
<b>Result</b>	Reading of indicator's outputs' status (see the following explanation).

A bit is ascribed to each input:

Bit not managed														Board outputs	
Bit 15	Bit 14	Bit 13	Bit 12	Bit 11	Bit 10	Bit 9	Bit 8	Bit 7	Bit 6	Bit 5	Bit 4	Bit 3	Bit 2	RL 2	RL 1
														Bit 1	Bit 0

Therefore if the OUTS00002 string is received, the hexadecimal value, converted into binary, indicates that the status of the outputs is the following:

Bit not managed														Board outputs	
Bit 15	Bit 14	Bit 13	Bit 12	Bit 11	Bit 10	Bit 9	Bit 8	Bit 7	Bit 6	Bit 5	Bit 4	Bit 3	Bit 2	RL2	RL 1
														Bit 1	Bit 0
0	0	0	0	0	0	0	0	0	0	0	0	0	0	1	1

The active outputs are therefore RL 1 and, RL 2.

### NOTES:

- The reading command of the outputs does not work in the set-up environment
- No output is ascribed to bits from 2 to 15 bits and these are fixed at zero.

## Enabling/disabling of the output command:

### Syntax

<b>Format</b>	<CC><II> OUTPNVVVV <CR LF>
<b>Parameters</b>	<ul style="list-style-type: none"> <li>- N = output number (expressed in hexadecimal)</li> <li>- 0 to activate simultaneously all the outputs</li> <li>- from 1 to 2 to identify the single output which one wants to enable.</li> <li>- VVVV = enabling/disabling code;</li> <li>- for the single output, V = 0000 disabled, while V = 0001 enabled.</li> <li>- for all the outputs (in other words N = 0), the value identifies the outputs to be enabled (expressed in hexadecimal).</li> </ul>
<b>Answer</b>	<p>&lt;CC&gt;&lt;II&gt;OK&lt;CR LF&gt;</p> <p>The answer does not imply that the command has been made on the output or all the set outputs.</p>
<b>Example</b>	<ESC>01OUTP00003<CR LF>
<b>Result</b>	Configuration of the outputs (see the following explanation)

A bit is ascribed to each output:

Bit not managed														Board outputs	
Bit 15	Bit 14	Bit 13	Bit 12	Bit 11	Bit 10	Bit 9	Bit 8	Bit 7	Bit 6	Bit 5	Bit 4	Bit 3	Bit 2	RL 2	RL 1
														Bit 1	Bit 0

The bit at 1 is interpreted as active output, while the bit at 0 as disabled output.

If, for example, one wants to enable simultaneously the **R1** and **R2** outputs, the binary combination will be

Bit not managed														Board outputs	
Bit 15	Bit 14	Bit 13	Bit 12	Bit 11	Bit 10	Bit 9	Bit 8	Bit 7	Bit 6	Bit 5	Bit 4	Bit 3	Bit 2	RL 2	RL 1
														<b>Bit 1</b>	<b>Bit 0</b>
0	0	0	0	0	0	0	0	0	0	0	0	0	0	1	1

Which, in hexadecimal, corresponds to the number 0003; therefore the command will be OUTP00003 + CR + LF.

### NOTES:

- The set point enabling command does not work neither in the set-up environment nor in the weighing phase; if the setpoint mode has been selected and the output function is different than "none" (rif. output step, *FUnC* parameter).
- No output is ascribed to the bits from 2 to 15 and are fixed at zero.

## 7.6 TRANSMISSION PROTOCOLS

The weight data transmission on the PC and PRN serial ports may take place in 3 formats: STANDARD STRING, EXTENDED STRING or MULTISCALE STRING.

### 7.6.1 STANDARD STRING

STRING TRANSMITTED IN THE DEPENDENT CHANNEL AND INDEPENDENT CHANNEL MODE

**[CC]hh,kk,pppppppp,uu + CR + LF**

STRING TRANSMITTED IN THE TRANSM MODE:

**[CC]hh,pppppppp,uu + CR + LF**

in which: **[CC]** INSTRUMENT CODE IN THE FORMAT OF TWO ASCII DECIMAL DIGITS  
ONLY IN THE CASE THAT THE 485 PROTOCOL IS SELECTED (FOR EXAMPLE 00).

**hh** UL Under load (not transmitted in the "TRANSM" mode)  
OL Over load (not transmitted in the "TRANSM" mode)  
ST Stability of the display  
US Instability of the display

, Comma character

**kk** NT Net Weight  
GS Gross Weight  
GX Gross weight with sensitivity times 10  
VL Value in micro volts relative to the weight  
RZ Value in converter points relative to the weight

, Comma character

**pppppppp** 8 digits (including any sign and decimal point) which identify the weight. The insignificant digits are filled with spaces. Through the MVOL and RAZF command the indicator transmits the relative value on 10 digits instead of 8.

**uu** Unit of measurement "kg" "bg" "bt" "lb" "mv" (microvolts) "vv" (converter points)  
**CR** Carriage Return (13 ascii decimal character).  
**LF** Line Feed (10 ascii decimal character).

The transmitted weight is the GROSS weight (GS) if no TARE WEIGHT has been entered; otherwise, the NET WEIGHT (NT) will be transmitted.

## 7.6.2 EXTENDED STRING

Without APW (only in a mode other than **counting** or in response to the REXT command):

**[CC]B, hh, NNNNNNNNNN, YTTTTTTTTTT, PPPPPPPPPP, uu, (dd/mm/yybbhh:mm:ss|"NO DATE TIME") + CR + LF**

With APW (only in **piece counting** mode or in response to the REXT command):

**[CC]B, hh, NNNNNNNNNN, YTTTTTTTTTT, PPPPPPPPPP, AAAA.AAAAA, uu + CR + LF**

in which:

<b>[CC]</b>	INSTRUMENT CODE IN THE FORMAT OF TWO ASCII DECIMAL DIGITS JUST IN CASE THE 485 PROTOCOL IS SELECTED (FOR EXAMPLE 00)
<b>B</b>	scale number (1 in scale with equalized channel mode ("DEP.CH"), the channel number from 1÷4 in scale with independent channels mode ("IND.CH").
<b>,</b>	Comma character
<b>hh</b>	UL Under load OL Overload ST Stability of display US Instability of display
<b>,</b>	Comma character
<b>NNNNNNNNNN</b>	net weight on 10 characters including possible sign and decimal point
<b>,</b>	Comma character
<b>YY</b>	"PT" if the tare is manual, otherwise YY = " " (two empty spaces) if the tare is semiautomatic.
<b>,</b>	Comma character
<b>TTTTTTTTTT</b>	tare weight on 10 characters including possible sign and decimal point.
<b>,</b>	Comma character
<b>PPPPPPPPPP</b>	number of pieces on 10 characters, equal to 0 if the indicator is in a functioning mode other than the counting mode.
<b>,</b>	Comma character
<b>AAAA.AAAAA</b>	Average Piece Weight on 10 characters with 5 decimals. The Average Piece Weight is always reported in grams.
<b>,</b>	Comma character
<b>uu</b>	Unit of measure "Kg" "bg" "bt" "lb"
<b>,</b>	Comma character (only with REXD command)
<b>dd/mm/yy</b>	Date in the "dd/mm/yy" format (only with REXD command)
<b>bb</b>	2 space characters, ascii decimal 32 character (only with REXD command)
<b>hh:mm:ss</b>	Time in the "hh:mm:ss" format (only with REXD command)
<b>CR</b>	Carriage Return (ascii decimal 13 character)
<b>LF</b>	Line Feed (ascii decimal 10 character)

The non significant digits of the net, tare, pieces and gross weights are filled with spaces (space characters, ascii decimal 32 character).

If the optional TIME DATE board has not been detected, in response to the REXD command, only the weight is transmitted and not the date and time; in its place there is "NO DATE TIME".

### 7.6.3 MULTISCALE STRING

The string varies depending upon the configured channels:

#### Chan. Transmitted string

- 1 [CC]hh,pppppppp,uu, (dd/mm/yybbhh:mm:ss|"NO DATE TIME") + CR + LF
- 2 [CC]hh,pppppppp,uu,hh,pppppppp,uu, (dd/mm/yybbhh:mm:ss|"NO DATE TIME") + CR + LF
- 3 [CC]hh,pppppppp,uu,hh,pppppppp,uu,hh,pppppppp,uu, (dd/mm/yybbhh:mm:ss|"NO DATE TIME") + CR + LF
- 4 [CC]hh,pppppppp,uu,hh,pppppppp,uu,hh,pppppppp,uu,hh,pppppppp,uu, (dd/mm/yybbhh:mm:ss|"NO DATE TIME") + CR + LF

in which:

**[CC]** = INSTRUMENT CODE IN THE FORMAT OF TWO ASCII DECIMAL DIGITS ONLY IF THE 485 PROTOCOL HAS BEEN SELECTED (FOR EXAMPLE 00)

For each set channel:

<b>hh</b>	ST	Stability of the display
	US	Instability of the display
	VL	Value in microvolts relative to the weight
	RZ	Value in converter points relative to the weight

, Comma character

**pppppppp** 8 digits (including eventual sign and decimal point) which identify the weight. The insignificant digits are filled with spaces. Through the MVOL and RAZF commands the indicator transmits the relative value on 10 digits instead of 8.

, Comma character

**uu** Unit of measure "kg" "bg" "bt" "lb" "mv" (microvolts) "vv" (converter points)

, Comma character (only with REXD command)

**dd/mm/yy** Date in the "dd/mm/yy" format (only with REXD command)

**bb** 2 space characters, ascii decimal 32 character (only with REXD command)

**hh:mm:ss** Time in the "hh:mm:ss" format (only with REXD command)

**CR** Carriage Return (ascii decimal 13 character)

**LF** Line Feed (ascii decimal 10 character)

If the optional TIME DATE board has not been detected (standard only in DGTP/DGTPK version), in response to the REXD command, only the weight is transmitted and not the date and time; in its place there is "NO DATE TIME".

#### LEGEND:

**b** space character, 32 decimal ascii character.





## 9. MASTER/SLAVE AND REPEATER MODES CONFIGURATIONS

These configurations are possible only if in the instrument there is the master firmware

### 9.1 REPEATERS

#### 9.1.1 *rEPE. dC*

The "RepeaterDC Protocol" is a communication protocol designed to control one or more remote weigh repeater(s) connected via a serial line possibly shared with digital cells, in order to make the best use of a single connection.

Packets are sent by the weigher instrument to the repeater(s) at the end of a digital-cells enquire loop, one ID for each loop, when at least 100ms are elapsed from the last packet transmission. This means that a minimum interval of 100ms between repeaterDC packets is guaranteed.

If no digital-cell is connected, RepeaterDC packets are sent with a fixed 100ms interval.

No acknowledge message from receiver is expected.

In the weighers you can select the number of scales. After that, when you set the "*rEPEdC*" protocol it's requested, for each scale present and for the sum of all, if you want to see these always or never or (only if the scale or the sum is selected). In the repeater, after you have select the protocol, is necessary going to "*Add. En*" step and select the number of the scale then you will see, or the following number of the last scale for view the sum. You can use this protocol with 232 (analog cells) or with 485 (analog/digital cells).

#### Analog cells

DGT4 (ripetitore)		3590E/CPWE-AF03/AF08	
<i>F. ModE</i>	<i>FUnct: rEPE</i>	<i>coPIAUH</i>	<i>Protoc: r iPEdc</i>
<i>PC. ModE</i>	<i>rEPE. dc</i>		
<i>Add. En</i>	X		
<i>PC SEL</i>	485/232		
<i>bit</i>	n-8-1		

#### Digital cells:

DGT4 (ripetitore)		3590E/CPWE-AF03/AF08	
<i>F. ModE</i>	<i>FUnct: rEPE</i>	<i>coPIAUH</i>	<i>Protoc: r iPEdc</i>
<i>PC. ModE</i>	<i>rEPE. dc</i>		<i>сЕЛтУР: X</i>
<i>Add. En</i>	X		<i>PRr itY: even</i>
<i>PC SEL</i>	485		<i>Word: 7 bit</i>
<i>bit</i>	E-7-1		<i>StoP b: 1 bit</i>

In a single line to be connect in series 3590, digital cells and SCT-100

#### 9.1.2 *rEPE. B*

Simple repetition of the DFW's screen in the SCT-100. Can be use both in 232 and in 485. The repeater keys are disable.

Configuration:

#### DFW

DGT4 (repeater)		DFW	
<i>F. ModE</i>	<i>FUnct: rEPE</i>	<i>PCModE</i>	<i>rEPEB</i>
<i>PCModE</i>	<i>rEPE. B</i>		
<i>Add. En</i>	no		
<i>PC SEL</i>	485/232		

#### 3590/CPWE

DGT4 (repeater)		3590/CPWE	
<i>F. ModE</i>	<i>FUnct: rEPE</i>	<i>PCModE</i>	<i>Cont</i>
<i>PCModE</i>	<i>rEPE. B</i>	<i>Protoc</i>	<i>r iPE B</i>
<i>Add. En</i>	no		
<i>PC SEL</i>	485/232		

### 9.1.3 rEPE.in

Intelligent repeater reads all the string; the operator can select, in the technical setup, the string's start and the part of this referred to the weight. You can be use both in 232 and in 485. The repeater keys are disable. Configuration:

DFW:

DGT4 (repeater)		DFW	
F. ModE	Funct: rEPE	PCModE	ALL. Std
PCModE	rEPE.in		
Add. En	no		
PC SEL	485/232		

3590/CPWE:

DGT4 (repeater)		3590/CPWE	
F. ModE	Funct: rEPE	PCModE	Cont
PCModE	rEPE.in	Protoc	Stand
Add. En	no		
PC SEL	485/232		

After you set these parameters is necessary to go in weighing mode with the weigher instrument. With SCT-100 you go in "PC mode" step, and set rEPE.in. the display will shown `Con. AIP`. press print; now, if the communication is correct the display shown `WE rFY` and after it receives the string; now select the start of the string and press PRINT, after that you have see `SEEP`. now select the first and the last characters of the weight. Escape from the setup and save the configurations.

## 9.1.4 $\Delta$ . rEPE

It repeats the weight of the remote scale connected, with this protocol you have the possibility to simulate "Zero" and "Tare" keys.

The parameters to set in the repeater are described above (see section 4.2  $\rightarrow$   $\Gamma$   $\Delta$   $\Gamma$ .  $P\Gamma$ ) and they are variable depending on the connected scale.

Example of standard string sent from a DFW:

String	h	h	,	k	k	,	p	p	p	p	p	p	p	,	u	u	CR	LF	
Character position	00	01	02	03	04	05	06	07	08	09	10	11	12	13	14	15	16	17	18

Example of configuration for the standard string parameters of DFW instruments:

```

tErn  $\rightarrow$  10 (LF)
 $\Delta$ E i. P05  $\rightarrow$  06
 $\Delta$ E i. LEn  $\rightarrow$  08
Str. LEn  $\rightarrow$  18
dEC i  $\rightarrow$  2
Unit  $\rightarrow$  KG
StAb  $\rightarrow$  10
StA. int  $\rightarrow$  06
trShLd  $\rightarrow$  tr. Lo  $\rightarrow$  -999.99
tr. hi  $\rightarrow$  9999.99
Adu. CEd  $\rightarrow$   $\Delta$ . nEt  $\rightarrow$  nASH  $\rightarrow$  255
n. bYtE  $\rightarrow$  3
uALUE  $\rightarrow$  78 ("N" in the ASCII code)

nEG. S iG  $\rightarrow$  nASH  $\rightarrow$  0
StAb iL  $\rightarrow$  nASH  $\rightarrow$  255
n. bYtE  $\rightarrow$  0
uALUE  $\rightarrow$  83 ("S" in the ASCII code)

 $\Delta$ . zEr0  $\rightarrow$  nASH  $\rightarrow$  0

Und. our  $\rightarrow$  nASH  $\rightarrow$  255
n. bYtE  $\rightarrow$  1
uALUE  $\rightarrow$  76 ("L" in the ASCII code)

```

## 9.2 MASTER/SLAVE

Repetition of the weight on the SCT-100 and possibility of using the SCT-100 keys to simulate those of the slave.

Configuration:

DFW

DGT4 (Master)		DFW (slave)	
<i>F. Node</i>	<i>Func: Master nUNSL: X L iStEn: no Protocol: EHtEnd t. HEY: Hb. dFU</i>	<i>PCNode</i>	<i>485; Add485: X (number of the slave)</i>

For 485 connection, you connect the "DF485" board and connect the two indicators, using the terminal of this board and setting "485" in PCSEL of SCT-100.

With this configuration we can enabled in the SCT-100, both the relays and the analog output. The analog output is programmed as relative paragraph (see section 9), as well as for relays. For set the relays switching on and off, is necessary to turn off the slaves

3590

232 connections

DGT4 (Master)		3590 /CPWE (slave)	
<i>F. Node</i>	<i>Func: Master nUNSL: X L iStEn: no Protocol: EHtEnd t. HEY: Hb. CPWE</i>	<i>PCNode</i>	<i>485; Add485: X (number of the slave)</i>
<i>PCSEL</i>	<i>232</i>		

Con connessione 485:

DGT4 (Master)		3590 /CPWE (slave)	
<i>F. Node</i>	<i>Func: Master nUNSL: X L iStEn: no Protocol: EHtEnd t. HEY: Hb. CPWE</i>	<i>Port5</i>	<i>Com3: PC</i>
<i>PCSEL</i>	<i>485</i>	<i>PCNode</i>	<i>485; Add485: X (number of the slave)</i>

## 10. ANALOGUE OUTPUT (OPTIONAL, AVAILABLE DEPENDING ON THE MODEL)

In all the functioning modes, through an optional interface, it is possible to use an analogue output configurable at 0-20mA, 4-20mA, 0-10Vdc, 0-5Vdc ; with minimal and maximal value settable. The voltage and the output current from the interface are proportional to the gross weight or net weight present on the scale. In regards to the electrical connection scheme, refer to the section "CONNECTION SCHEMES".

If the instrument has the MASTER type firmware, the functioning of the analogue output is possible when it is connected to an instrument of the following series: DGT, DFW, 3590E, CPWE. In this cases, one has to select the *EHtEnd* parameter in the *PrObol* step on the MASTER (see the section "MULTISCALE REPEATER [MASTER] . USER MAN.REF.).

**Note:** The analogue output is updated every 20ms and takes on the value corresponding to the weight converted in that instant; therefore if the filter is slowed on the weight, the analogue output also slows down.

For configuring the parameters, one should enter the setup environment and enter in the *SEtUP* → *ConF iG→An. oUt* step.

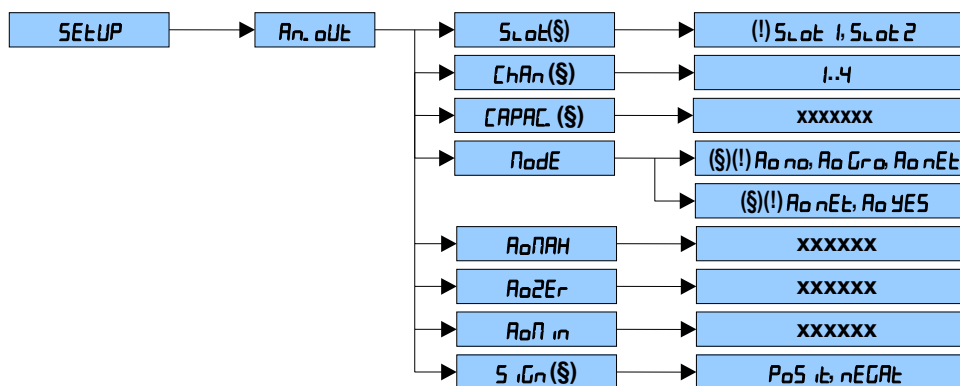

### ➤ SLoT (\$)

One selects the slot to be used with the analogue output: SLoT 1 or SLoT 2; it is possible to indifferently use either slot. By default, it uses the Slot 1.

(§) The parameter is displayed only in the DGTP and DGTPK models.

### ➤ ChAn (\$)

By entering this step, one selects the channel to be configured (from 1 to 4).

**NOTE:** The parameter is not displayed if one has set "dEP. Ch" in the *tYPE* parameter or in case of one channel application, step *SEtUP* → *ConF iG→nChAn*.

(§) The parameter is not displayed if the firmware is MASTER type and with DGT1 and DGT1S models.

### ➤ CAPAC. (\$)

In this step one enters the capacity of the slave. One has to set the corresponding value, without the decimal point (for example, if the capacity of the scale is 30,000kg, one has to insert 030000).

(§) The parameter is displayed only if the firmware is MASTER type.

### ➤ ModE(\$)

By entering this step one selects the type of functioning of the analogue output:

(§) Parameters displayed if the firmware is STANDARD type:

- AOn nO* = analogue output disabled.
- AOn GrO* = analogue output on gross weight.
- AOn nEt* = analogue output on net weight.

(§) Parameters displayed if the firmware is MASTER type:

- AOn nO* = analogue output disabled.
- AOn YES* = analogue output enabled.

Once the functioning mode is confirmed, one sets the values of the analogue output; in other words, the digital/analogue converter values are entered (between 0 and 65535) to which corresponds a certain output value in voltage or in current.

In this configuration the instrument keys take on the following meanings (functions):

- ZERO** → It decreases the selected digit (blinking).
- TARE** → It increases the selected digit (blinking)
- MODE** → It selects the digit (blinking) from left to right.
- PRINT** → By pressing once after have a value has been entered, it enables the corresponding output analogue value (allowing the check), but remains still inside the step in case of a new modification. By pressing a second time (on the same entered value), it confirms and exits the step.
- C** It allows to quickly zero the present value.

**NOTE:** The functioning mode is just one for all the configured channels.

➤ **Ro PAH**

By entering this step, one sets the maximum value of the analogue output, in other words:

- with functioning on the positive weight → the value of the output when the weight is greater than or equal to the full scale capacity and also corresponding to the overload condition.
- with functioning on the negative weight → the value of the output when the negative weight in absolute value is greater than or equal to the full scale capacity and also corresponding to the underload condition.

This value can be anywhere between 0 and 65535 (values of the digital/analogue converter); if a higher value is entered, the instrument zeros it.

➤ **Ro ZEr**

By entering this step, one sets the analogue output value when the scale displays zero weight (supplied when the scale is in under load). This value can be anywhere between 0 and 65535 (values of the digital/analogue converter); if a higher value is entered, the instrument zeros it.

➤ **Ro P in**

By entering this step, one sets the minimum value of the analogue output, in other words:

- with functioning on the positive weight → the minimum value provided by the analogue output, corresponding also to the underload condition.
- with functioning on the negative weight → the minimum value provided by the analogue output, corresponding also to the overload condition.

This value can be anywhere between 0 and 65535 (values of the digital/analogue converter); if a higher value is entered, the instrument zeros it.

➤ **S iGn**

By entering this step, one sets the functioning on the negative or positive weight.

It's not possible to set the functioning on the negative gross weight; for this purpose the parameter in the STANDARD type firmware is displayable only in the functioning on the net weight (  $R_o nEt$  parameter).

In the MASTER type firmware the functioning on the negative weight is not managed.

**APPROXIMATE VALUES BETWEEN THE D/A CONVERTER AND ANALOGUE OUTPUT**

D/A CONVERTER VALUES	VOLTAGE VALUE (V)	CURRENT VALUE (mA)
1200	0	0
12700		4
58600		20
62650	10	

## Graphics:

### Functioning on the positive weight

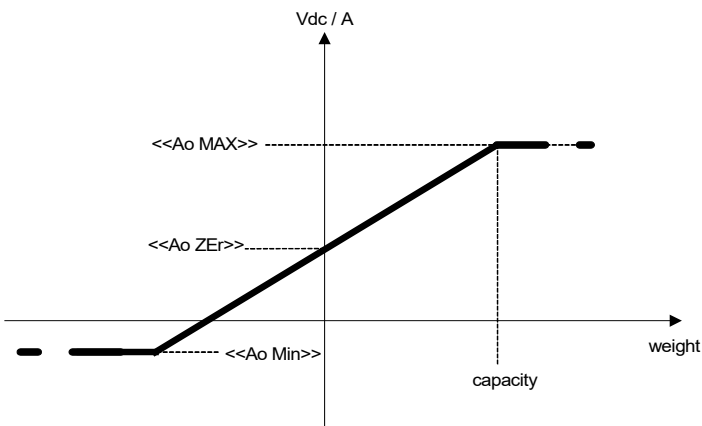

### Functioning on the negative weight

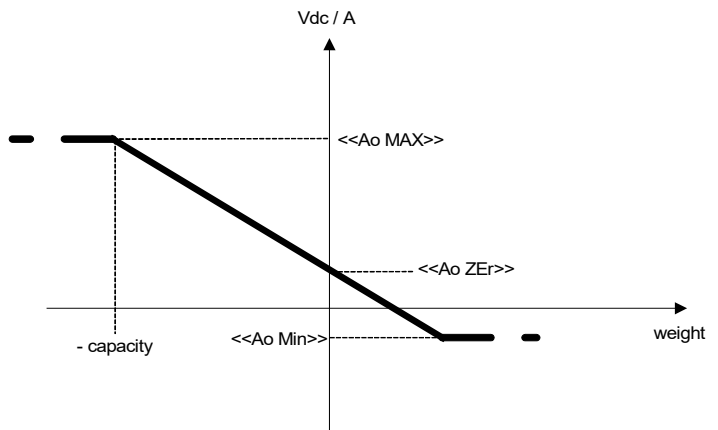

## 11. PROGRAMMING THE PRINTOUTS

If in the set-up environment the presence of the printer has been configured correctly, the indicator carries out the print functions; each functioning mode has specific printouts, shown in the "PRINT EXAMPLES" section in the user manual (**USER MAN.REF.**). In any case, it is possible to define some printing fields, the size of the characters, a heading and other options depending on the printer and the predefined functioning mode.

In the "Pr. ModE" step of the set-up environment it is possible to select whether to print on the TPR printer or the LP542S (LP542P) labeller; see the following steps for all the printing options.

- 1) Enter the SET-UP environment of the scale (when turned on, press for an instant the **TARE** key while the firmware version is displayed).
- 2) Select the **SEtUP** → **SErIAL** → **CoN. Prn** → **Pr. ModE** step and press **PRINT**.
- 3) Select the desired printer [**TPR**] or [**LP542P**] and press **PRINT**.
- 4) In the section "SET-UP ENVIRONMENT" see the descriptions of the "baud. Pr.", "bit. Pr.", "Pr. Prn.", "ser. Pr. in" and "Prn. CTS" steps for configuring the baud rate, the number of transmission bits, the printer's power supply and the CTS signal.
- 5) Select the "Pr. Conf" step and press **PRINT**: one enters the **PROGRAMMING MENU OF THE PRINTOUTS**. Below is the description of the steps.
- 6) Once the setting have been made, press the **C - ON/OFF** key various times until the indicator shows "SERUP" in the display: confirm with **PRINT** to memorize and return to weighing.

### ➤ Pr. Conf CONFIGURATION OF THE PRINTOUTS (§)

In this step one enters the print programming submenu.

**(§) the parameter and all its submenus are displayed only if "TPR" or "LP542P" has been selected in the "Pr. ModE" step and the single scale repeater mode ("rEPE") is not enabled (in the MASTER type firmware).**

### ➤ LANG PRINTING LANGUAGE

One selects the language in which the printouts are carried out:

- **ITAL** = italian.
- **ENGL** = english.
- **DEUT** = german.
- **FRAN** = french.
- **ESPA** = spanish.

(!) **ITAL**

➤ **b.L nE** EMPTY LINE AT THE BEGINNING OF THE PRINTOUT (§)

- **YES** = at the beginning of each printout an empty line is inserted.
- **no** = no empty line.

(!) **YES**

(§) The parameter is displayed only if the **EPF** parameter has been selected in the **Pr. ModE** step.

➤ **IntES** PRINTING OF HEADING

In the MASTER type firmware (§)

- **h. no** = no heading.
- **h. 1.SL** = headers printed when the 1st slave print is executed.
- **h. SLUS** = headers printed when the slaves prints are executed.
- **h. SUP** = headers printed when the sum is printed.
- **ALWAYS** = headers always printed.

(!) **h. no**

In the STANDARD type firmware (§)

- **Int no** = no heading.
- **Int S,** = prints the heading; in the totalizer mode it is printed only upon the first totalisation (in other words if the partial total is zero).
- **Int F,** = prints the heading; in the totalizer mode it is printed in all the totalisations.
- **Int. SUP** = prints the heading; in the totalizer mode it is printed in all the totalisations and in the partial total.

(!) **Int no**

➤ **NUMBE** PRINTING OF NUMBER OF WEIGHS (ONLY FOR TOTALIZER MODE)

- **no** = does not print the number of weighs.
- **tot** = prints the number of weighs only in the single totalisation.
- **SUP** = prints the number of weighs only in the partial total.
- **both** = prints the number of weighs in the totalisations as well as in the partial total.

**NOTE:** the parameter is displayed only if the "totalizer" functioning mode has been selected.

(!) **both**

➤ **doM** PRINTS DATE AND TIME

In the MASTER type firmware

- **dt. no** = the date and time are not printed.
- **dt. in. 1** = date and time are printed in the sum only and using the printer clock.
- **dt. in. 2** = date and time are always printed using the printer clock.
- **dt. EH. 1** = date and time are printed in the sum only and using the scale clock, if detected.
- **dt. EH. 2** = date and time are always printed using the scale clock, if detected.

(!) **dt. no**

In the STANDARD type firmware

- **dt. no** = the date and time are not printed.
- **dt. in. 1** = the date and time are printed using the clock inside the printer; in the totalizer functioning mode the date and time are printed just in the total and not in the single totalizations
- **dt. in. 2** = as above, but in the totalizer functioning mode the date and time are printed also in the single totalizations.
- **dt. EH. 1** = like "dt. in. 1" but the indicator's date and time board (optional) is used.
- **dt. EH. 2** = like "dt. in. 2" but the indicator's date and time board (optional) is used.

**NOTE:** The date and time is printed, if programmed, before the possible barcode, which is always at the end of the printout

(!) **dt. no**

➤ **nEt H PRINTS TICKET NUMBER (§)**

The ticket number is a sequence number which increases upon each printing made, this number, between 1 and 65535, is kept in memory also when the instrument is turned off.

(§) In the MASTER type firmware, the step is displayed only if the date/time optional board is detected.

In the MASTER type firmware (§)

- **no** = no ticket number is printed.
- **SLAVES** = ticket number is printed when the slaves prints are executed.
- **SUM** = ticket number is printed when the sum is printed.
- **ALWAYS** = ticket number is always printed.
- **RESET** = reset the ticket number, sets it to 1 and leaves the **nEt H** step unchanged.

(!) **no**

In the STANDARD type firmware (§)

- **no** = does not print the ticket number.
- **YES. tot** = prints the ticket number; in the totalizer functioning mode it is printed only in the single totalisations.
- **SUM** = prints the ticket number; in the totalizer functioning mode it is printed just in the partial total.
- **both** = prints the ticket number; in the totalizer functioning mode it is printed in the totalisations as well as in the partial total.
- **RESET** = by pressing PRINT the sequence number in the ticket is zeroed.

(!) **no**

**NOTE:** The ticket number, if programmed, is printed after the weight data.

➤ **EndPAGE SELECTION OF PAGE END PRINTING**

This step allows to print 2 empty lines at the end of each printout (if "LP" is selected in the "Pr. ModE" step) or an end label (if "LP542P" is selected in the "Pr. ModE" step).

In the MASTER type firmware (§)

- **no** = does not print the page end.
- **SLAVES** = prints the end page when the slaves prints are executed.
- **SUM** = prints the end page when the sum is printed.
- **ALWAYS** = end page is always printed.

(!) **SLAVES**

In the STANDARD type firmware (§)

- **no** = does not print the page end
- **YES. tot** = prints the end page; in the totalizer functioning mode it is printed just in the single totalisations.
- **SUM** = prints the end page; in the totalizer functioning mode it is printed just in the partial total.
- **both** = prints the end page; in the totalizer functioning mode it is printed in the totalisations as well as in the partial total.

(!) **YES. tot**

➤ **LErN SETTING TERMINATOR**

When connecting a printer it is often necessary to transmit one of the following protocols in order to define the end of the print line.

- **Cr** = CR (for DP190, LP542P/S, TPR)
- **CrLF** = CR LF (for EPSON LX300 and TMU295).

(!) **Cr**

➤ **PFOrN PRINT FORMATTING**

In this step one enters a submenu for selecting the weight data which one wants to print and the print layout. Depending on the type of printer selected in the *Pr. ModE* step (*LP542P* or *tPr*), the parameters which are suggested, change.

➤ *nr. CoP* NUMBER OF TICKET COPIES

Through this step one sets the number of ticket copies which will be printed, valid for any type of printout and functioning mode.

The possible values are *103*.

(!) *1*

### 11.1 FORMATTING DATA AND LAYOUT

Depending on the type of selected printer in the *Pr. ModE* step [*LP542P* o *tPr*]. the suggested parameters are different.

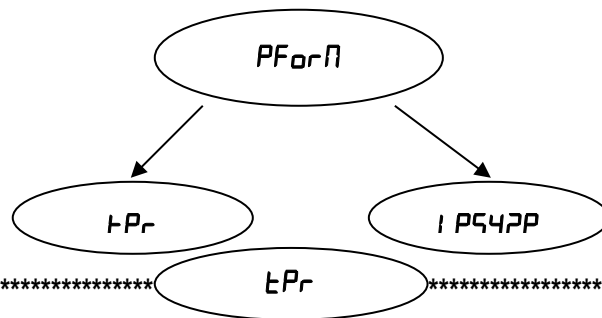

*dEFAUL* PRINTOUT DEFAULT (\$)

Through this step one enables the default printing relative to the selected functioning mode.

The default sets, in each of the following steps, the value marked with the (!) symbol.

(§) The parameter is not displayed if the firmware is MASTER type.

➤ *F iLdS* PRINTING FIELDS (\$)

Through this step it is possible to select which fields to be printed among those available:

- *G*
- *n*
- *t*
- *G n*
- *G t*
- *n G*
- *n t*
- *t G*
- *t n*
- *G n t*
- *G t n*
- *n G t*
- *n t G*
- *t G n*
- *t n G*

(in which "*G*" is the gross weight; *n* is the net weight and *t* is the tare weight).

(!) *G t n*

(§) The parameter is not displayed if the firmware is MASTER type.

➤ *hE iGht* FONT HEIGHT SELECTION FOR PRINTING THE WEIGHT DATA, DATE AND TIME, PROGRESSIVE NUMBERS AND ID'S (\$)

- *ChAr 1* = normal height
- *ChAr 2* = double height

(!) *ChAr 1*

(§) The parameter is not displayed if the firmware is MASTER type.

➤ *bArC* PRINTS THE BAR CODE (\$)

In this step one programmes the printing of the 39 CODE (if "tPr" has been selected in the "Pr.ModE" step), which will be printed before the printing of the date and time:

- **no** = does not print the bar code.
- **YES. tot** = prints the bar code; in the totalizer functioning mode it is printed just in the single totalisations.
- **5UP** = prints the bar code; in the totalizer functioning mode it is printed just in the partial total.
- **both** = prints the bar code; in the totalizer functioning mode it is printed in the totalizations as well as in the partial total.

(!) **no**

(§) The parameter is not displayed if the firmware is MASTER type.

**NOTES:**

- the weight values are expressed in 6 digits without decimal point and with the possible non significant zeros present.
- between a weight value and the following one a space is inserted.
- the bar code is printed as the last data, after the weight values, possible numeric codes and ticket number, but before the date and time (with DP190 or TPR printer).

**THE FOLLOWING PARAMETERS ARE VISIBLE ONLY IF IN THE PREVIOUS STEP A PARAMETER DIFFERENT FROM "no" HAS BEEN SET.**

➤ **udbAr** **SELECTING THE BAR CODE'S VERTICAL DISTANCE OF THE PRECEDING TEXTS:**

In lines with normal height font, programmable value: 0...9.

(!) 0

• **LnbAr** **SELECTION OF LEFT MARGIN**

Expressed in 1/8 of a mm (from 1 to 99).

(!) 0 1

• **'bAr** **SELECTION OF BAR CODE FONT WIDTH:**

Programmable value: W1...W3

(!) ' 1

• **hbAr** **SELECTION OF BAR CODE FONT HEIGHT:**

Expressed in 1/8 of mm (from 0 to 255)

(!) 000

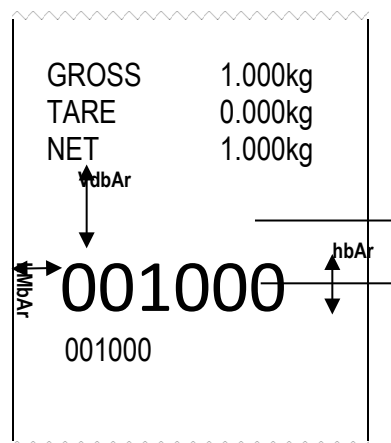

• **bArFS** **SELECTION OF PRINT FIELDS IN THE BAR CODE:**

Programmable value: G; n; t.

In which "G" is gross weight, n is net weight and t is tare weighing.

(!) G

• **Pntub** **PRINTING OF THE BAR CODE'S NUMERIC FIELD**

This step allows to select the printing of the bar code's numeric field:

- **no** = the numeric field is not printed.
- **UndEr** = under the bar code
- **AbouE** = above the bar code
- **Ab'Un** = both above as well as below the bar code.

(!) **AbouE**

• **PtEst** **PRINT TEST**

By pressing PRINT, a label is printed of the fields previously selected, **but with fixed weight values.**

The print test depends on the selected functioning mode:

**Std mode:** the first time the fields with the unit of measure in kg are printed, the second time the fields with the unit of measure in lb are printed, and on this way

**netGS, StP G, StP n, ul SS, AL ib i, inoUt mode**: simple printout.

**PARSEr mode**: not settable.

**hold mode**: the first time the fields without the "HOLD" indication are printed, the second time the fields with the "HOLD" indication, and on this way.

**PERH mode**: the first time the fields without the "PERH" indication are printed, the second time the fields with the "PERH" indication, and on this way.

**tot 0 Mode and tot 5 mode**: when the PRINT key is pressed there will be a selection menu with the following items:

- "tot. 1. 0" = simulates the printing of the first totalisation relative to storage zero.
- "tot. 2. 0" = simulates the printing of another totalisation relative to storage zero.
- "SUM 0" = simulates the printing of the partial total relative to storage zero.
- "tot. 1. 1" = simulates the printing of the first totalisation relative to storage one.
- "tot. 2. 1" = simulates the printing of another totalisation relative to storage one.
- "SUM 1" = simulates the printing of the partial total relative to storage one.
- "Gtotal" = simulates the printing of the general total.

**Coln mode**: the first time the fields are printed with the Number of Pieces and the APW, the second time the fields are printed without the Number of Pieces and the APW.

LP542P

\*\*\*\*\*

**PREMISE:** the purpose is to create the label directly onto the indicator, by configuring the parameters described below.

Once the programming is done, one will need to download the label onto the printer (*download* step) and then save it in its permanent memory; carefully read the section “SAVING THE LABEL IN THE LABELLER’S PERMANENT MEMORY”.

➤ **DEFAULT: PRINTOUT DEFAULT (§)**

In this step one enables the default printout relative to the selected functioning mode.  
The default sets, in each of the following steps, the value marked by the (!) symbol.  
(§) The parameter is not displayed if the firmware is MASTER type.

➤ **FIELD5: PRINT FIELDS (§)**

In this step it is possible to select which fields to print among the available ones:

- G
- n
- t
- G n
- G t
- n G
- n t
- t G
- t n
- G n t
- G t n
- n G t
- n t G
- t G n
- t n G

(in which G is the gross weight, n is the net weight and t is the tare weight).

(!) G t n

(§) The parameter is not displayed if the firmware is MASTER type.

➤ **CHAR.t: FONT TYPE WITH WHICH THE WEIGHT DATA, DATE AND TIME, PROGRESSIVE NUMBERS AND ID'S ARE PRINTED.**

- CHAR. 1 = the data is printed by using the font which will be programmed in the CHAR 1 step.
- CHAR. 2 = the data is printed by using the font which will be programmed in the CHAR 2 step.

See **EXAMPLE 1**.

(!) CHAR 1

➤ **LABELW: LABEL WIDTH (IN MM)**

Enter a value with 3 digits, expressed in mm.

(!) 53

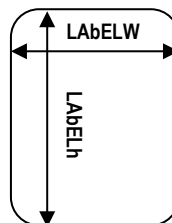

➤ **LABELh: LABEL HEIGHT**

Enter a value with 3 digits, expressed in mm.

(!) 80

➤ **CHAR 1: SELECTING THE FONT WITH WHICH THE DATA LINKED TO THIS CHARACTER WILL BE PRINTED**

(!) Font. 3d

➤ ChAr 2: SELECTING THE FONT WITH WHICH THE DATA LINKED TO THIS CHARACTER WILL BE PRINTED.

(!) Font. 3d

It is possible to select for each letter one of the following fonts:

PARAMETER	TYPE OF FONT (WIDTH X HEIGHT)
Font. 1	1 x 1,5 mm
Font. 1d	1 x 3 mm
Font. 2	1,5 x 2,5 mm
Font. 2d	1,5 x 5 mm
Font. 3	2 x 3 mm
Font. 3d	2 x 6 mm
Font. 4	3 x 4 mm
Font. 4d	3 x 8 mm
Font. 5	4 x 6 mm
Font. 5d	4 x 12 mm

**EXAMPLE 1:** one wants to print 4 heading lines, of which the first two are double the height in respect to the second two, GROSS, TARE, NET, DATE and TIME.

One will programme:

in the heading, LinE 1 and LinE 2 = ChAr 2

LinE 3 and LinE 4 = ChAr 1

ChAr. 1 = ChAr 1

ChAr 1 = Font. 3

ChAr 2 = Font. 3d

**Result:**

DIMENSION = ChAr 2 →

DIMENSION = ChAr 1 →

DIMENSION = ChAr 1 →

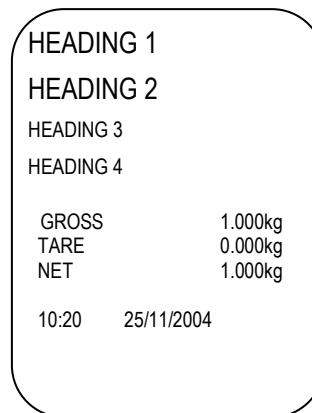

➤ t.MARg: DISTANCE OF THE DATA PRINTED FROM THE LABEL'S UPPER MARGIN

Enter a value with 3 digits, expressed in mm

(!) 10

➤ L.MARg: DISTANCE OF THE DATA PRINTED FROM THE LABEL'S LEFT MARGIN

Enter a value with 3 digits, expressed in mm

(!) 4

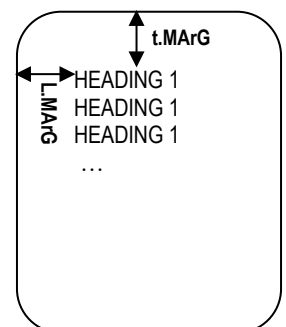

➤ bARc: PRINTING THE BAR CODE (ONLY CODE 39 TYPE) (§)

- no = does not print the bar code.

- YES. tot = prints the bar code; in the totalizer functioning mode it is printed just in the single totalisation.

- SUP = prints the bar code; in the totalizer functioning mode it is printed just in the partial total.

- both = prints the bar code; in the totalizer functioning mode it is printed both in the totalisations as well as in the partial total.

(!) no

(S) The parameter is not displayed if the firmware is MASTER type.

**NOTES:**

- the weight values are expressed with 6 digits without decimal point and possibly with non significant zeros.
- between a weight value and the following one a space is inserted
- the bar code is printed as the last data, after the weight values, numeric codes and ticket number, but before the time and date.

**THE FOLLOWING PARAMETERS ARE VISIBLE ONLY IF IN THE PREVIOUS STEP A PARAMETER DIFFERENT FROM "no" HAS BEEN SET.**

- **v. d. bArC:** SELECTING THE VERTICAL DISTANCE OF THE BAR CODE FROM THE PREVIOUS TEXTS:

Enter a value with 3 digits, expressed in mm

(!) 5

- **L. M. bArC:** SELECTING THE LEFT MARGIN

Enter a value with 2 digits, expressed in mm

(!) 15

- **h. bArC=** SELECTING BAR CODE HEIGHT

Enter a value with 2 digits, expressed in mm

(!) 10

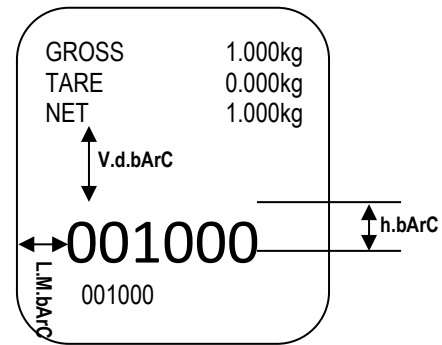

- **bArF5:** SELECTING THE PRINT FIELDS IN THE BAR CODE

Selectable fields:

- G
- n
- t
- G n
- G t
- n G
- n t
- t G
- t n
- G n t
- G t n
- n G t
- n t G
- t G n
- t n G

In which G is the gross weight, n is the net weight and t is the tare weight.

(!) n

- **Printub:** PRINTING THE NUMERIC FIELD OF THE BAR CODE

- no = the numeric field is not printed.
- YES = the numeric field is printed under the bar code

(!) YES

➤ PEEL: CONFIGURATION OF THE SENSOR WHICH PEELS OFF THE LABEL

- `ON` = sensor active
- `OFF` = sensor not active
- (!) `OFF`

➤ GAP: SETTING THE VERTICAL DISTANCE BETWEEN A LABEL AND THE FOLLOWING ONE

Enter the value in mm.

**NOTE:** if one uses a continuous form, set the value 00.

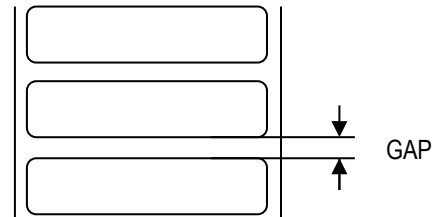

➤ dirECT: SETTING THE PRINT DIRECTION

- `dirECT` = direct printing
- `reVERSE` = upside down printing
- (!) `dirECT`

GROSS	1.000kg
TARE	0.000kg
NET	1.000kg

*dirECT*

NET	1.000kg
TARE	0.000kg
GROSS	1.000kg

*reVERSE*

➤ dir.EHT: SETTING OF THE TYPE OF FORMAT

- `F. int` = format created through the indicator
- `F. EHTn` = format created with the programme or tool on PC

➤ do!nLd: TRANSMISSION & TEMPORARY SAVING OF THE LABEL PROGRAMMED IN THE LABELLER

This step temporarily saves the label in the labeller memory; by turning it off it causes the loss of the saved data.

**Carefully read the section "SAVING THE LABEL IN THE LABELLER'S PERMANENT MEMORY".**

➤ L. AL iGn: ALIGNMENT OF THE LABEL IN THE PRINTER

➤ PEESE: PRINTING TEST

By pressing PRINT, a test label is printed of previously selected fields, **but with fixed weight values.**

The print test depends on the selected functioning mode:

**Std mode:** the first time the fields with the kg unit of measure are printed, the second time the fields with the lb unit of measure are printed, and so on.

**netGS, ul 55, AL ib i, l noUt modes:** simple printing.

**PARSEr mode:** not settable.

**HQLd mode:** the first time the fields without the "HQLd" message are printed, the second time the ones with the "HQLd" message are printed, and so on.

**PEAH mode:** the first time the fields without the "PEAH" message are printed, the second time the ones with the "PEAH" message are printed, and so on.

**tot o and tot s mode:** when the PRINT is pressed a selection menu appears with the following items:

- `"E0E. 1. 0"` = simulates the printing of the first totalisation relative to the zero registry.
- `"E0E. 2. 0"` = simulates the printing of a further totalisation relative to the zero registry.
- `"SUR 0"` = simulates the printing of the partial total relative to the zero registry.
- `"E0E. 1. 1"` = simulates the printing of the first totalisation relative to the one registry.
- `"E0E. 2. 1"` = simulates the printing of a further totalisation relative to the one registry.

- "SUN I" = simulates the printing of the partial total relative to the one registry.
- "GtoRL" = simulates the printing of the general total.

**COUN mode:** the first time the fields with the pieces number and apw are printed, the second time the ones without the pieces number and apw are printed.

## !! IMPORTANT !!

### 11.1 SAVING THE LABEL IN THE LABELLER'S PERMANENT MEMORY

Once the programming of the label has made, one should:

1. Download the label created in the labeller → press PRINT when the display shows the "dō'nd" step.
2. Press the **C - ON/OFF** key; the display shows the message "L. SAvE": press the PRINT key to save the label created in the labeller's permanent memory.

When saving the data on the labeller, the green led blinks; while this happens do not do anything with the indicator or the labeller.

The saving of the label ends when the led stops blinking.

The labeller has the label saved and is ready to print it; turning off the labeller does not cause the loss of the saved data.

**REPEAT THESE SAVING OPERATIONS EACH TIME THAT ONE MODIFIES THE LABEL OR THE DATA IN IT OR IF IT IS NECESSARY TO CHANGE THE FUNCTIONING MODE AFTER HAVING PROGRAMMED THE LABEL.**

**It is also possible to create or customize the label, by using the label creation programme supplied together with the labeller; refer to the labeller manual for further information.**

## 12. PRINTING THE HEADING

It is possible to programme from the PC the 4 alphanumeric heading lines of 24 characters each, which will be printed in the manner which has been programmed until these are cancelled or substituted.

One configures the heading by using the RL TOOLS software on the PC; by following the instructions of the relative manual, while to select the printing mode of the heading follow the procedure described below:

Enter in the TECHNICAL SET-UP → SEtUP → SEr ,AL → Cōn. Prn :

If the firmware is STANDARD type:

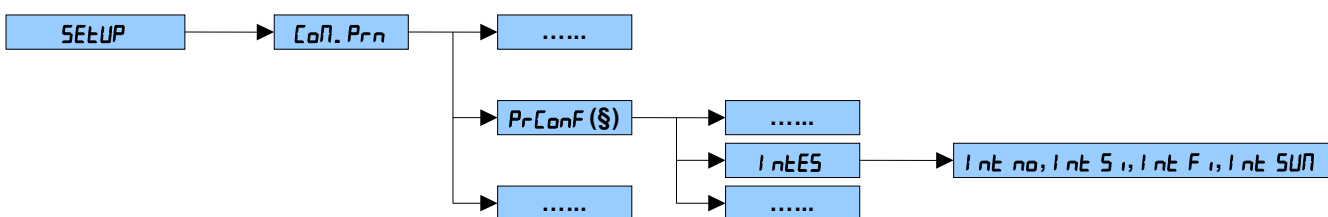

If the firmware is MASTER type:

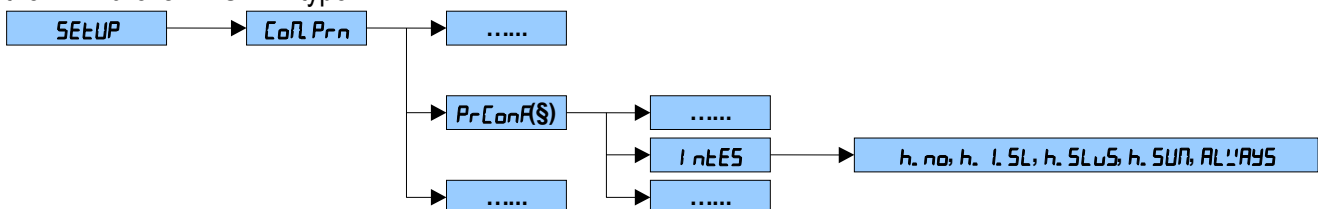

- 1) Enter in the step → *Coñ. Prrn*
- 2) Enter in the step → *Prr. CoñFC(\$)*
- 3) Enter in the step → *intES*
- 4) Select the heading printing mode:
  - in the STANDARD type firmware:
    - *int no* = does not print the heading
    - *int 5* = prints the heading (only with the first totalisation if a totalizer mode has been selected)
    - *int F i* = if a totalizer mode is selected, it prints the heading in all the totalisations
    - *int. SUP* = if a totalizer mode is selected, it prints the heading in all the totalisations in the total.
  - in the MASTER type firmware:
    - *h. no* = does not print the heading
    - *h. 1. SL* = heading printed when the 1st slave print is executed.
    - *h. SLuS* = heading printed when the slaves prints are executed.
    - *h. SUP* = heading printed when the sum is printed.
    - *ALWAYS* = heading always printed.

### 13. ERROR MESSAGES

While using the indicator, it is possible to incur in the following errors:

MESSAGE	DESCRIPTION
<i>PrEC.</i>	It is displayed if one tries to calibrate a point without first having confirmed the number of calibration points
<i>ErNot</i>	Weight unstable during the acquisition of a point during calibration.
<i>ErPnt</i>	During the acquisition of a calibration point a null value has been read by the converter.
<i>Err. H. 1</i>	Error which takes place if the capacity of channel X has not been set, or if there is an error in the calibration parameters of channel X, in which X indicates the number of channel to which the error refers to.
<i>Er-11</i>	Calibration error: a too small sample weight has been used; it is advisable to use a weight equal to at least half of the scale capacity.
<i>Er-12</i>	Calibration error: the acquired calibration point $[EP1 \text{ o } EP2 \text{ o } EP3]$ is equal to the zero point $[EP0]$ .
<i>Er-37</i>	Scale to be calibrated <b>TECH.MAN.REF.</b> (it is advisable to carry out a technical default, "DEFAULT" parameter, before proceeding). NOTE: press the →T← key before accessing the setup.
<i>Er-39</i>	Scale to be calibrated <b>TECH.MAN.REF.</b> (it is advisable to carry out a technical default, "DEFAULT" parameter, before proceeding). NOTE: press the →T← key before accessing the setup.
<i>C. Er. -36</i>	During the calibration some internal negative points have been calculated: <ul style="list-style-type: none"> <li>- the calibration point is less than the zero point.</li> <li>- the signal is negative (check the connections)</li> </ul>
<i>C. Er. -37</i>	During the calibration some internal points less than the minimum value have been calculated: <ul style="list-style-type: none"> <li>- the calibration point is equal to the zero point.</li> <li>- A capacity too high in relation to the division has been set.</li> </ul>
<i>H!-Err</i>	HARDWARE ERROR: software not compatible with the installed hardware; the hardware expansion component is missing which allows the software to function.

# 14. CONNECTION SCHEMES

## 14.1 SCT-100 / SCT-100AN MOTHERBOARD

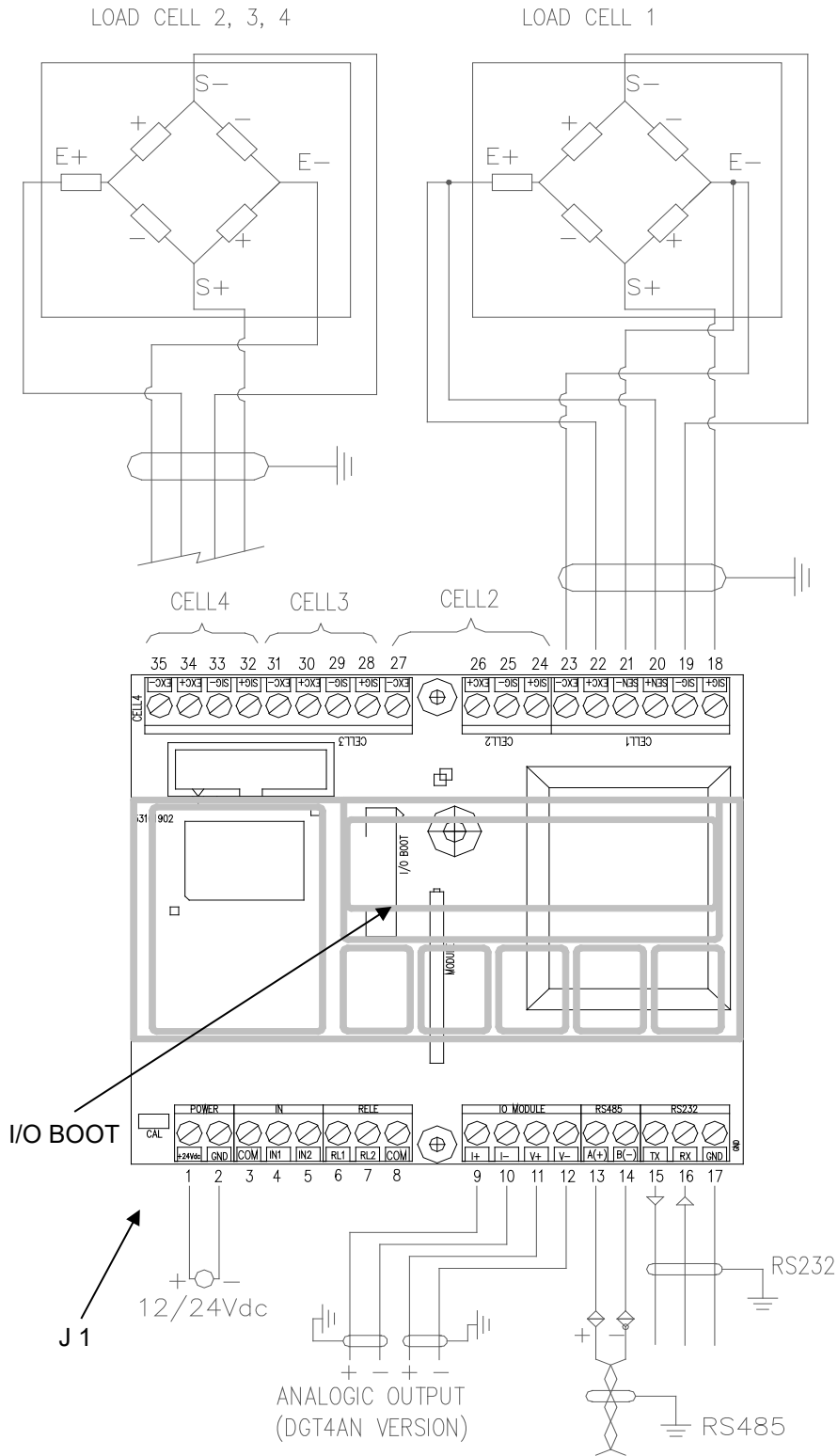

## MEANING OF SCT-100 / SCT-100AN TERMINAL BOARDS AND MOTHER BOARD JUMPERS

- **VE 12 / 24 Vdc POWER SUPPLY**

1. **+24Vdc** +12 / 24 Vdc
2. **GND** 0 Vdc (GND)

- **CELL LOAD RECEPTORS**

**CELL1:**

18. **SIG+** SIGNAL +
19. **SIG-** SIGNAL -
20. **SEN+** SENSE +
21. **SEN-** SENSE -
22. **EXC+** EXCITATION +
23. **EXC-** EXCITATION -

**!! IMPORTANT !!**

If one wants to use 4 wires in the CELL 1 terminal board (without using the SENSE signal), one should short-circuiting - SEN with -EXC and +SEN with +EXC.

**CELL2:**

24. **SIG+** SIGNAL +
25. **SIG-** SIGNAL -
26. **EXC+** EXCITATION +
27. **EXC-** EXCITATION -

**CELL3:**

28. **SIG+** SIGNAL +
29. **SIG-** SIGNAL -
30. **EXC+** EXCITATION +
31. **EXC-** EXCITATION -

**CELL4:**

32. **SIG+** SIGNAL +
33. **SIG-** SIGNAL -
34. **EXC+** EXCITATION +
35. **EXC-** EXCITATION -

- **CALIBRATION JUMPER**

**J1** = if closed, it enables the access to the metrological parameters

- **I/O BOOT**

Connector for the connection of the ALIBI MEMORY board or for the CLOCK board.

- **ANALOGUE OUTPUT (SCT-100AN)**

**On current:**

9. **I+** + 20 mA
10. **I-** 0 mA (GND)

**On voltage:**

11. **V+** + 10 V
12. **V-** 0 V (GND)

**Note:** the maximum resistance applicable on the output current is 350 Ohm and the minimum resistance applicable on the output voltage is 10 kohm.

- **RS 485 SERIAL PORT**

13. **A(+)** 485 + Line

14. **B(-)** 485 - Line

- **RS 232 SERIAL PORT**

15. **TX** Transmission

16. **RX** Reception

17. **GND** GND

- **INPUTS (OPTOISOLATOR PHOTOCOUPLERS) AND PHOTOMOSFET OUTPUTS**

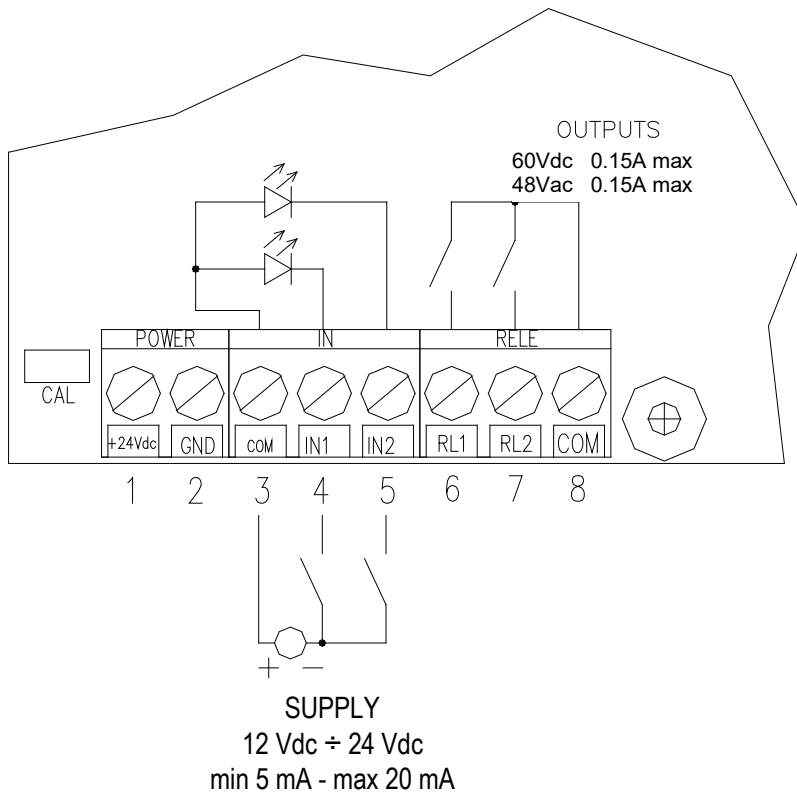

The maximum power of the outputs 48 Vac 0,15 A max (or 60 Vdc 0,15 A max), the maximum voltage applicable to the inputs is between 12 ÷ 24 Vdc with current from minimum 5 mA to maximum 20 mA.

# 14.2 SCT-100PB MOTHERBOARD

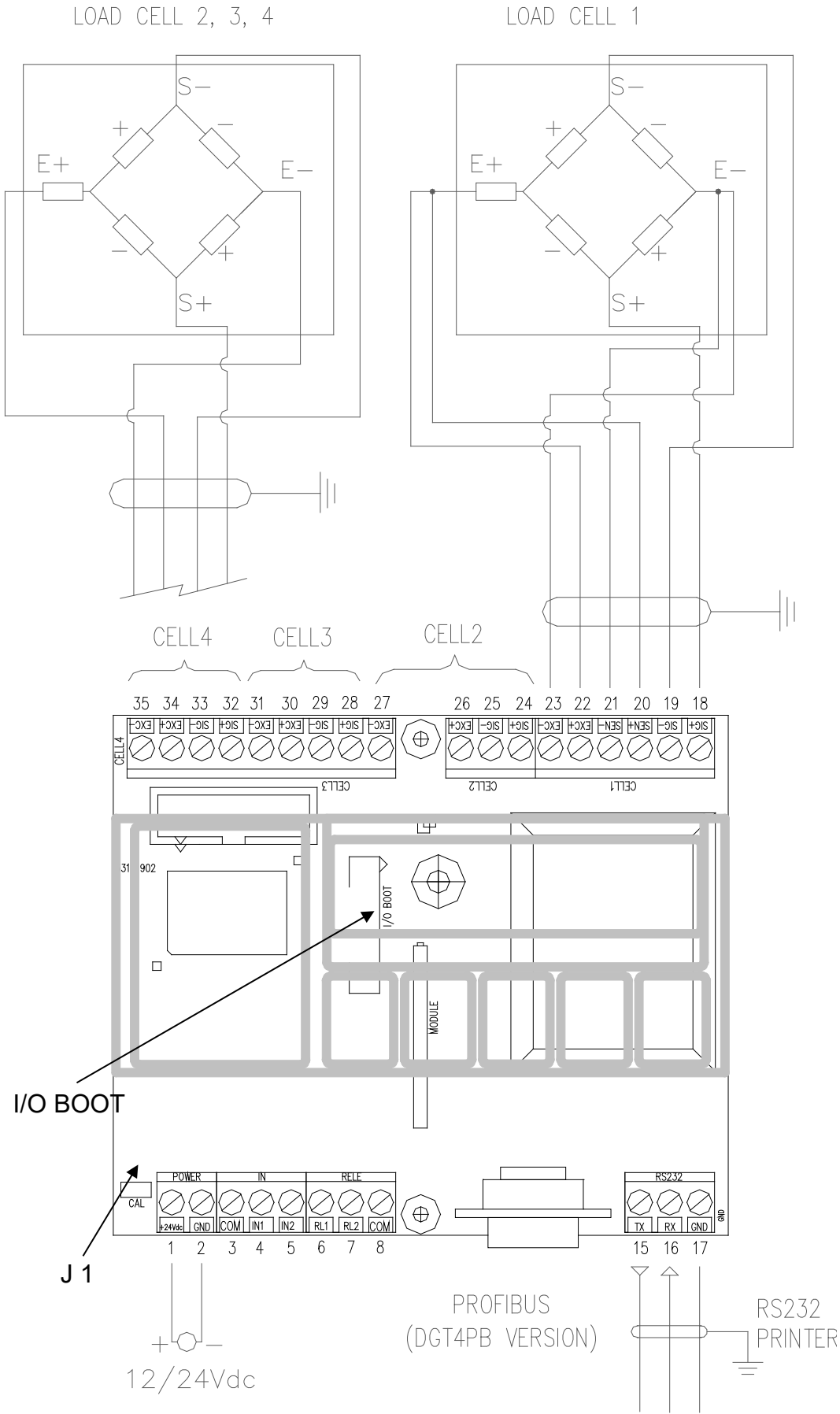

## MEANING OF SCT-100PB TERMINAL BOARDS AND MOTHER BOARD JUMPERS

- **VE 12 / 24 Vdc POWER SUPPLY**

1. **+24Vdc** +12 / 24 Vdc
2. **GND** 0 Vdc (GND)

- **CELL LOAD RECEPTORS**

**CELL1:**

18. **SIG+** SIGNAL +
19. **SIG-** SIGNAL -
20. **SEN+** SENSE +
21. **SEN-** SENSE -
22. **EXC+** EXCITATION +
23. **EXC-** EXCITATION -

**!! IMPORTANT !!**

If one wants to use 4 wires in the CELL 1 terminal board (without using the SENSE signal), one should short-circuiting - SEN with -EXC and +SEN with +EXC.

**CELL2:**

24. **SIG+** SIGNAL +
25. **SIG-** SIGNAL -
26. **EXC+** EXCITATION +
27. **EXC-** EXCITATION -

**CELL3:**

28. **SIG+** SIGNAL +
29. **SIG-** SIGNAL -
30. **EXC+** EXCITATION +
31. **EXC-** EXCITATION -

**CELL4:**

32. **SIG+** SIGNAL +
33. **SIG-** SIGNAL -
34. **EXC+** EXCITATION +
35. **EXC-** EXCITATION -

- **CALIBRATION JUMPER**

**J1** = if closed, it enables the access to the metrological parameters

- **I/O BOOT**

Connector for the connection of the ALIBI MEMORY board or for the CLOCK board.

- **RS 232 SERIAL PORT**

15. **TX** Transmission
16. **RX** Reception
17. **GND** GND

- PROFIBUS FEMALE CONNECTOR

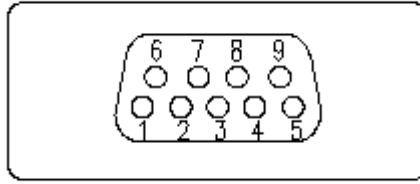

- 3. B-LINE
- 5. GND BUS
- 6. +5VBUS
- 8. A-LINE

- INPUTS (OPTOISOLATOR PHOTOCOUPPLERS) AND PHOTOMOSFET OUTPUTS

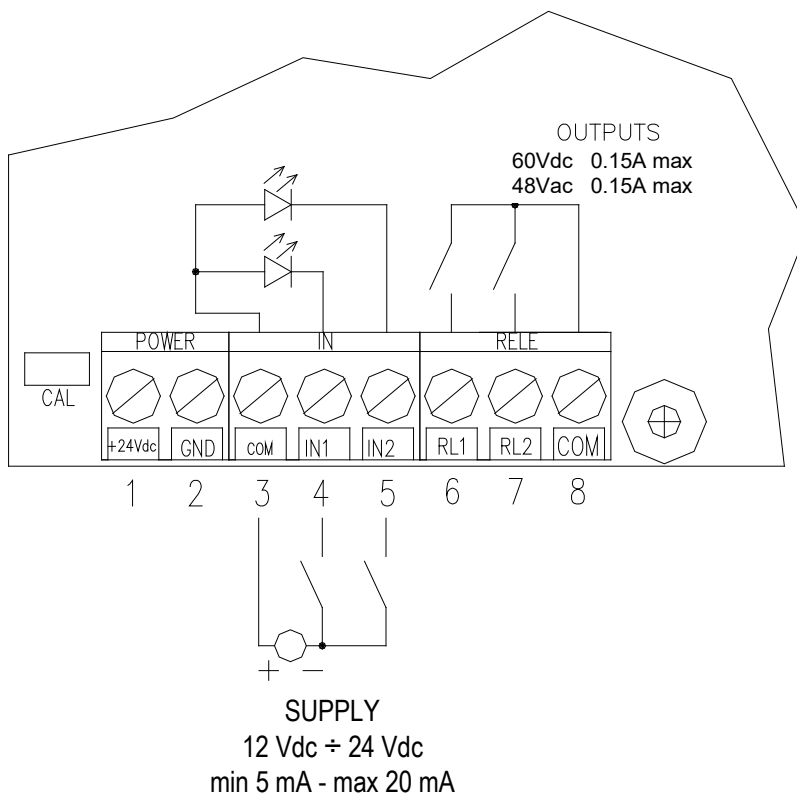

The maximum power of the outputs 48 Vac 0,15 A max (or 60 Vdc 0,15 A max), the maximum voltage applicable to the inputs is between 12 ÷ 24 Vdc with current from minimum 5 mA to maximum 20 mA.

## 14.3 RS 485 SERIAL PORT

On the same RS 485 line it's possible to connect up to 32 indicators.

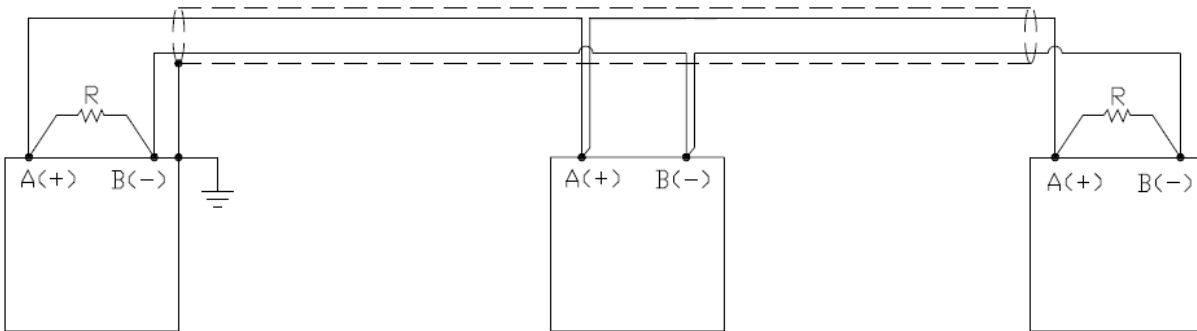

Figure 1: electrical diagram of the connections and the 2 termination resistances.

On the RS485 network normally one connects 2 termination resistances of 120 ohm (shown with "R" in figure 1), **ONLY** on the 2 devices **which are at the 2 ends of the cable**.

The maximum reachable length from the line with the use of the appropriate cable for RS 485 connections, the twisted 2x24 AWG duplex cable, shielded with external sheathing + aluminium band, is of about 1200 meters.







© Rice Lake Weighing Systems Specifications subject to change without notice.  
Rice Lake Weighing Systems is an ISO 9001 registered company.

230 W. Coleman St. • Rice Lake, WI 54868 • USA

U.S. 800-472-6703 • Canada/Mexico 800-321-6703 • International 715-234-9171 • Europe +31 (0)26 472 1319