

RLT Series

Indicators

Technical Manual

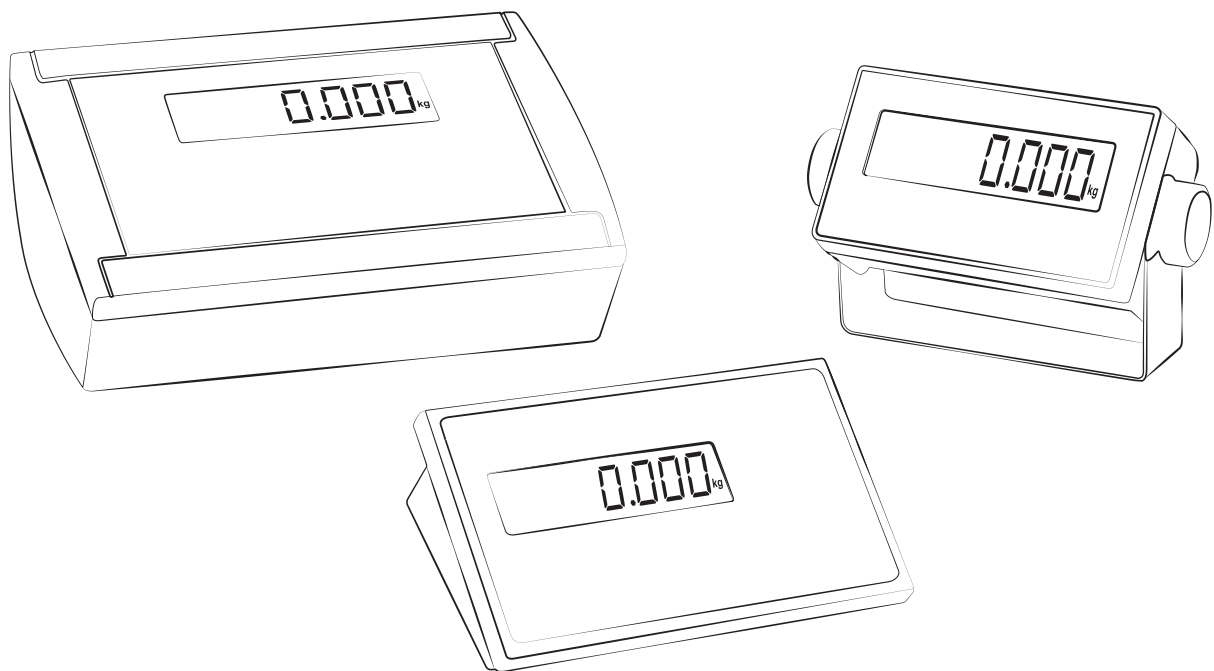

An ISO 9001 registered company
© Rice Lake Weighing Systems. All rights reserved.

Rice Lake Weighing Systems® is a registered trademark of
Rice Lake Weighing Systems.
All other brand or product names within this publication are trademarks or
registered trademarks of their respective companies.

All information contained within this publication is, to the best of our knowledge, complete and accurate at the time of publication. Rice Lake Weighing Systems reserves the right to make changes to the technology, features, specifications and design of the equipment without notice.

The most current version of this publication, software, firmware and all other product updates can be found on our website:

www.ricelake.eu

CONTENTS

1. Introduction and warnings	4
2. Technical features	4
3. Approval	5
4. Connections	6
Single channel	6
Multichannel.....	7
5. Programming	8
How to access the programming menu.....	8
How to save the programming and exit the menu.....	8
Programming menu	9
6. Communication strings	41
7. Communication controls	42
8. Wiring schemes	44
9. Programming errors	46
10. FAQ - Frequently Asked Questions	47
11. Summary of the parameters	48

CONTENTS BY TOPIC

Calibration

Quick calibration	10
Complete calibration	37

Equalization

Multichannel connection	7
Equalization procedure.....	36

Safety

Protection of the configuration menu via PIN.....	40
Protection of the user menu via PIN	40

Communication

Configuration of the serial port for PC.....	12
Configuration of the serial port for printer	14
Wiring schemes.....	44
Communication strings.....	41
Communication controls	42

Approval

Approval seal.....	5
Display of the metrological version	5

Reset

Factory configuration reset	33
Complete reset of memory	40

This product represents the best solution for multi-function weighing applications, offering ease of use, high precision in reading the weight and many functions to speed-up and simplify everyday work.

This manual provides an overview of the product's potentials: through the configuration menu, you can adapt the product functionality to the weighing application to be realized.



WARNINGS:

- Do not make repairs or replace electronic components of the instrument boards.
- Only use original spare parts.
- Any tampering with the equipment or use of non-original spare parts voids the warranty and relieves the manufacturer of any liability.
- Before any installation or repair that involves access to electronic parts, turn off the device and disconnect any source of power (battery, 230V network or other).
- Always use network power supply sources regulated within $\pm 10\%$ of the rated voltage.
- In applications in connection with third parties, always follow the specifications given on the approval decree of the equipment.
- Do not immerse in water.
- Do not wash with water jets (except versions with specific IP protection degree).
- Protect from direct rainfall (except versions with specific IP protection degree).
- Do not use cleaning solvents or substances.
- Do not install in potentially explosive environments.
- Earth connect any earth socket located on the equipment casing, using a cable with a diameter of at least 16 mm².

2. TECHNICAL FEATURES

Power supply via mains / Battery charger		110-230Vac
MAX consumption		5VA
Analog channels for reading of load cells		4
Managed / displayed scales		1
Connectable cells		16 da 350 Ohm
Load cells power supply		5V
Maximum load cells power supply current		20mA
Maximum operating temperature range CE-M - OIML		-10°C + 40°C
Maximum operating temperature range		-10°C + 60°C LCD/-20°C + 60°C LED
OIML divisions		10000e 3x3000e
Divisions for internal use		100d ... 1.000.000d
Optional Digital relays (only for DFW family)	Number	2 / 4
	Features	48 Vac, 60 Vdc, 15 mA, 10 Ω Max
Optional Digital inputs (only for DFW family)	Number	2 / 4
	Features	12 / 24 Vdc, 5:20 mA
Optional analog output (only for DFW family)		0:10 Vdc, 0:20 mA
Serial ports		2

3. APPROVAL

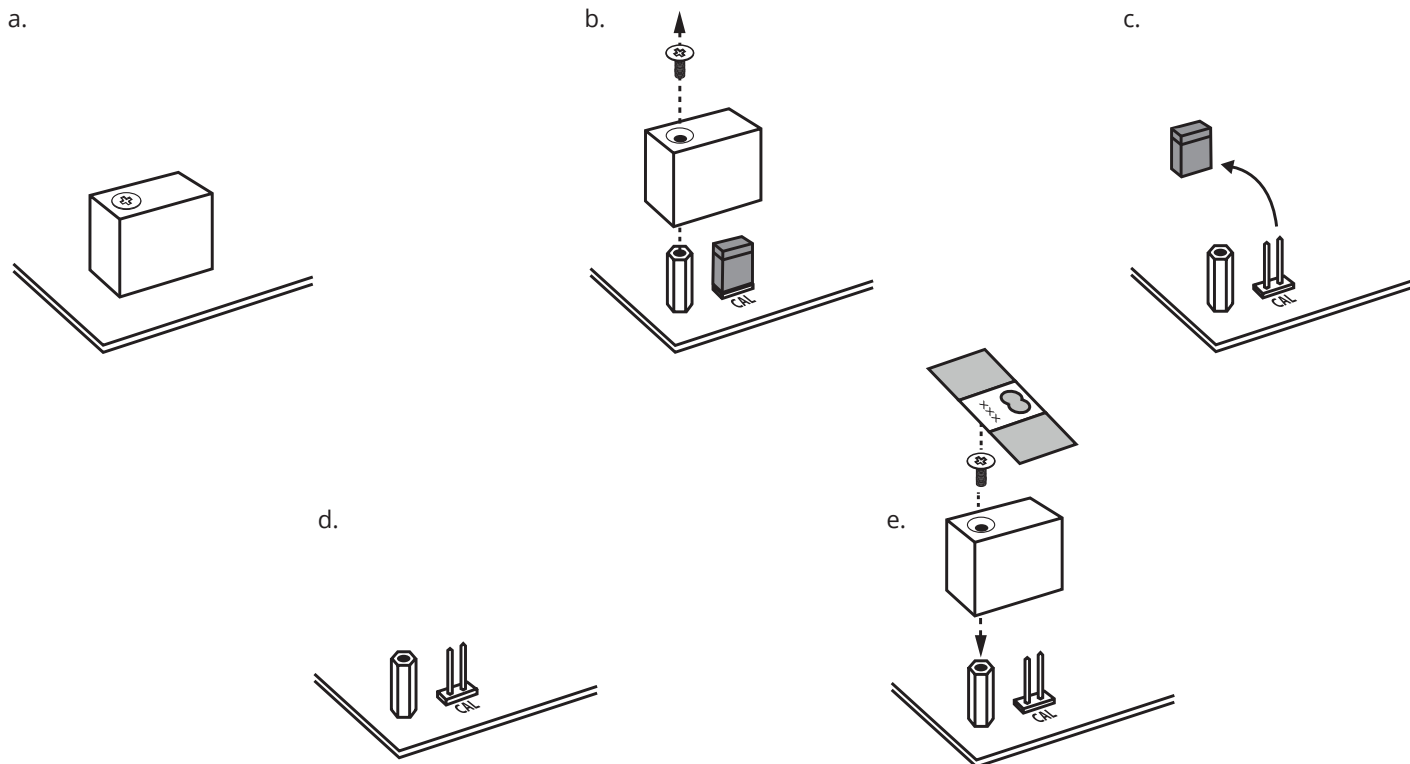

How to display the metrological version of the instrument

1. Turn off the scale

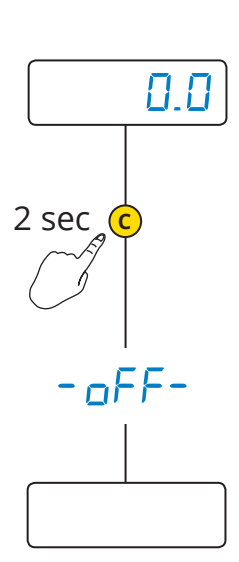

2. Follow the procedure:

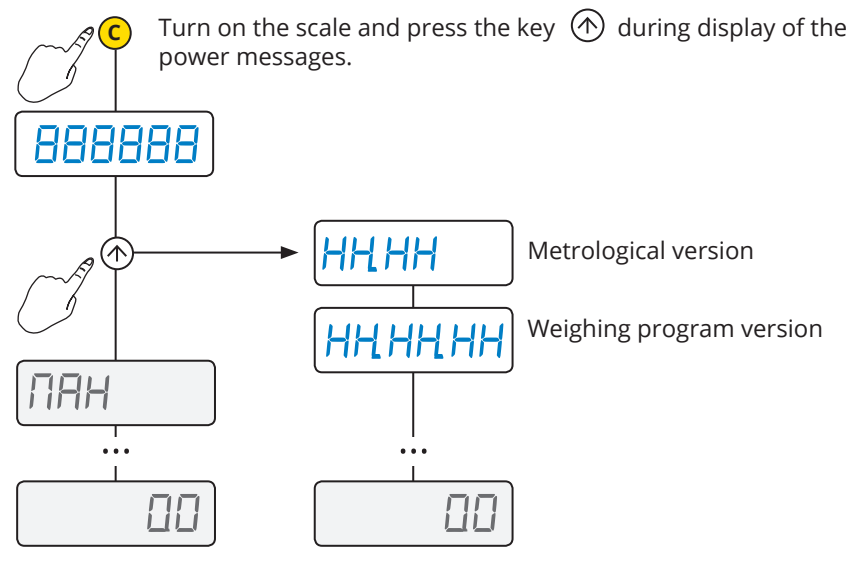

4. CONNECTIONS

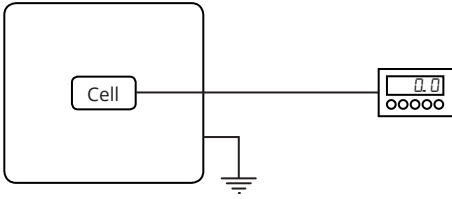

Single channel



Connect the scale to the main terminal board using the first reading channel of the A/D converter.

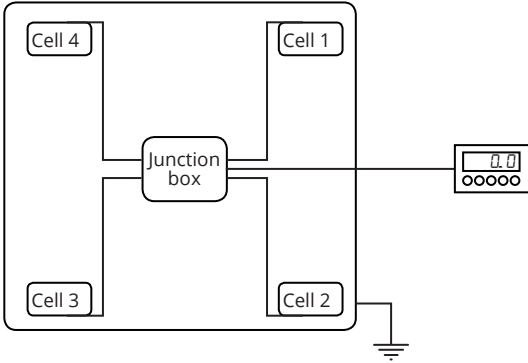

Terminal board of reference for connection to 1 channel

NOTES:

- For connection with 6 wires with "Sense", remove jumpers J2 and J3.
- For connection with 4 wires, install jumpers J2 and J3.



WARNING:

Make the connections with indicator off and feeder disconnected. Comply with the electronic specifications indicated in the table on page 4

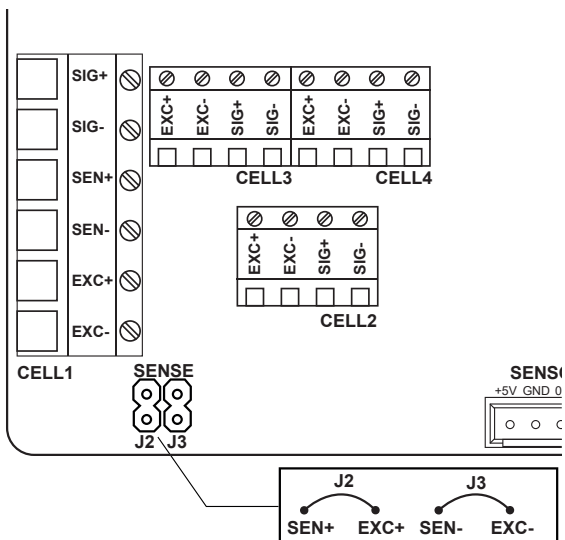

Multichannel with digital equalization

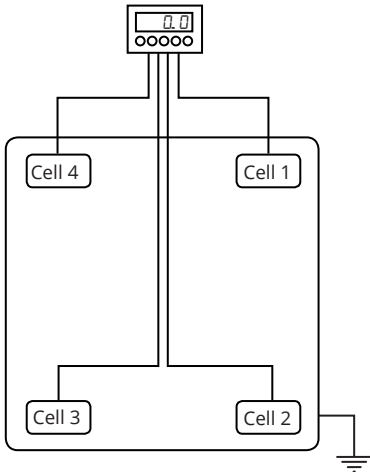

You can use the 4 channels of the converter to connect 2, 3 or 4 independent scales/cells, digitally equalizing them without using junction boxes.

Terminal boards of reference for connection to 4 channels

NOTES:

- Install jumpers J2 and J3.

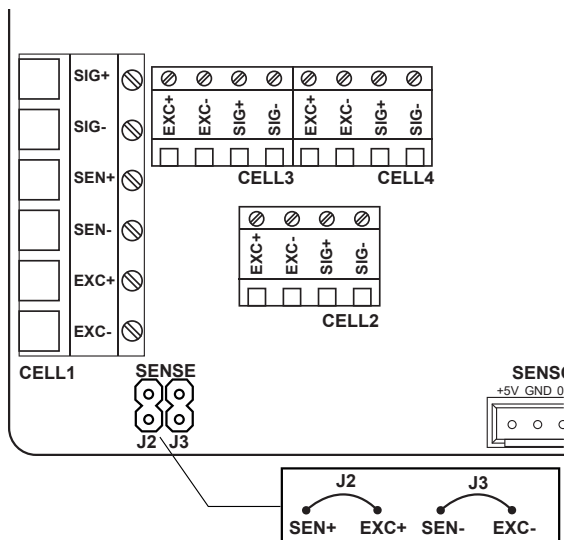

5. PROGRAMMING

How to access the programming menu



1. Turn off the scale

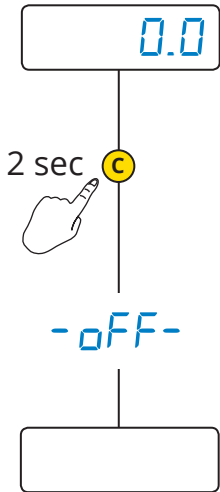

2. Follow the procedure:

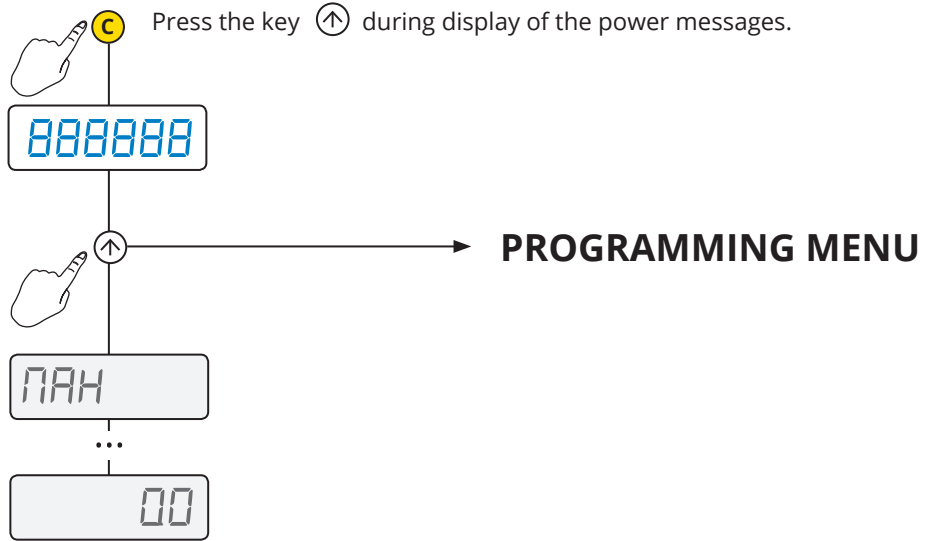

How to save the programming and exit the menu







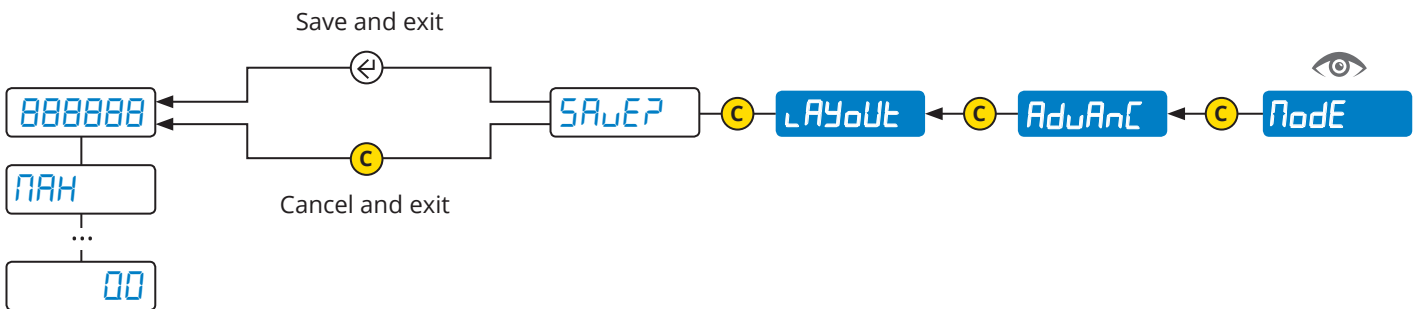





To save the programming changes made, repeatedly press the key **C** browsing the menu in reverse, until the message **SAVEP** appears: press **⬅** to save or **C** to exit without saving.

Example (read from right to left):



⚙️ PROGRAMMING MENU

	CAL	Quick calibration.....	10
	↓		
	QCAL	Reset of Pre-Tare (zero calibration).....	11
	↓		
	GrAV	Area of gravity of the place of use.....	11
	↓		
	SERIAL	Configuration of the serial ports.....	12
	↓		
	LAYoUt	Print customization.....	17
	↓		
	FILtEr	Weighing filter.....	25
	↓		
	SCrEEn	Adjusting the display.....	26
	↓		
	bAtt	Using the battery.....	27
	↓		
	ECo. bAtt	Energy saving.....	27
	↓		
	AUtoFF	Auto off.....	28
	↓		
	rEMotE	Using the remote control.....	28
	↓		
	AnoUt	Analog output.....	29
	↓		
	inPUTS	Digital inputs.....	31
	↓		
	oUtPUT	Digital outputs.....	32
	↓		
	rESEt	Factory configuration reset.....	33
	↓		
	dIAG	Diagnostics.....	33
	↓		
	AdvAnc	Advanced.....	34

 Parameter visible only in certain conditions.

 Parameter or menu subject to approval.

How to enter

1. Off
2. On
- 3.

Page 8

How to browse

- =
- =
- =
- =

How to save and exit



Page 8

- A **CAL**
- B QCAL
- C GrAV
- D SEr iAL
- E LAYoUt
- F FilteR
- G SCrEEr
- H bAtt
- I ECobAt
- J AUtoFF
- K rENotE
- L AnoUt
- M inPUtS
- N oUtPUt
- O rESEt
- P d iAG
- Q AduAnC



Start of the calibration procedure:

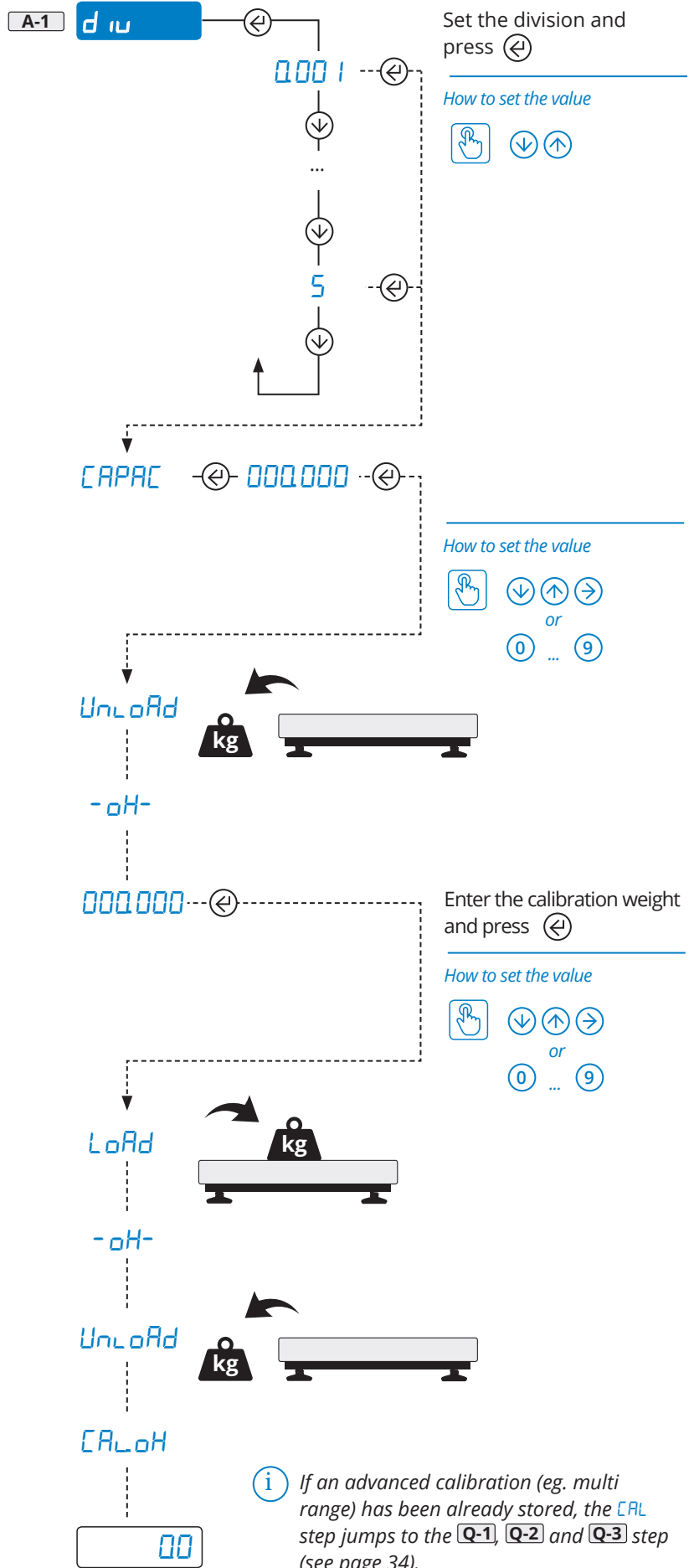

MENU

How to enter

1. Off
2. On
- 3.

Page 8

How to browse

- =
- =
- =
- =

How to save and exit



Page 8

A CAL

B QCAL

C GrAu

D SERIAL

E LAYOUT

F FILTER

G SCREEN

H bAtt

I ECabAt

J AUtoFF

K rENotE

L Anout

M inPUTS

N outPUT

O rESEt

P d iAG

Q AduAnC

QCAL Reset of the Pre-Tare



Acquisition of the zero point

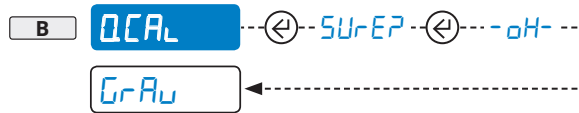

GrAu Area of gravity of the place of use



Once the calibration is completed, for proper operation set the area of use in this pitch (if different from that of calibration).

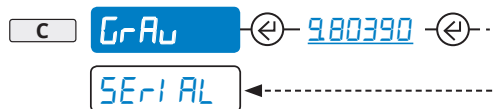

Area of gravity
(9.7500 1...9.84999)

How to set the value

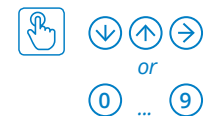









How to enter

1. Off 
2. On 
3. 

 Page 8

How to browse

-  = 
-  = 
-  = 
-  = 

How to save and exit



 Page 8

- A CAL
- B QCAL
- C CrAU
- D **SEr iAL**
- E LAYoUt
- F FilteR
- G SCrEEEn
- H bAtte
- I ECobAt
- J AUtoFF
- K rENotE
- L AnoUt
- M inPUtS
- N oUtPUt
- O rESEt
- P d iAG
- Q AdvAnC

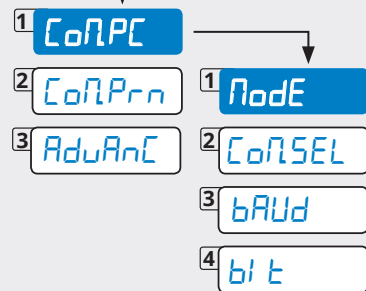

CoNPC Communication with PC, PLC or Repeater

Selection of the communication mode

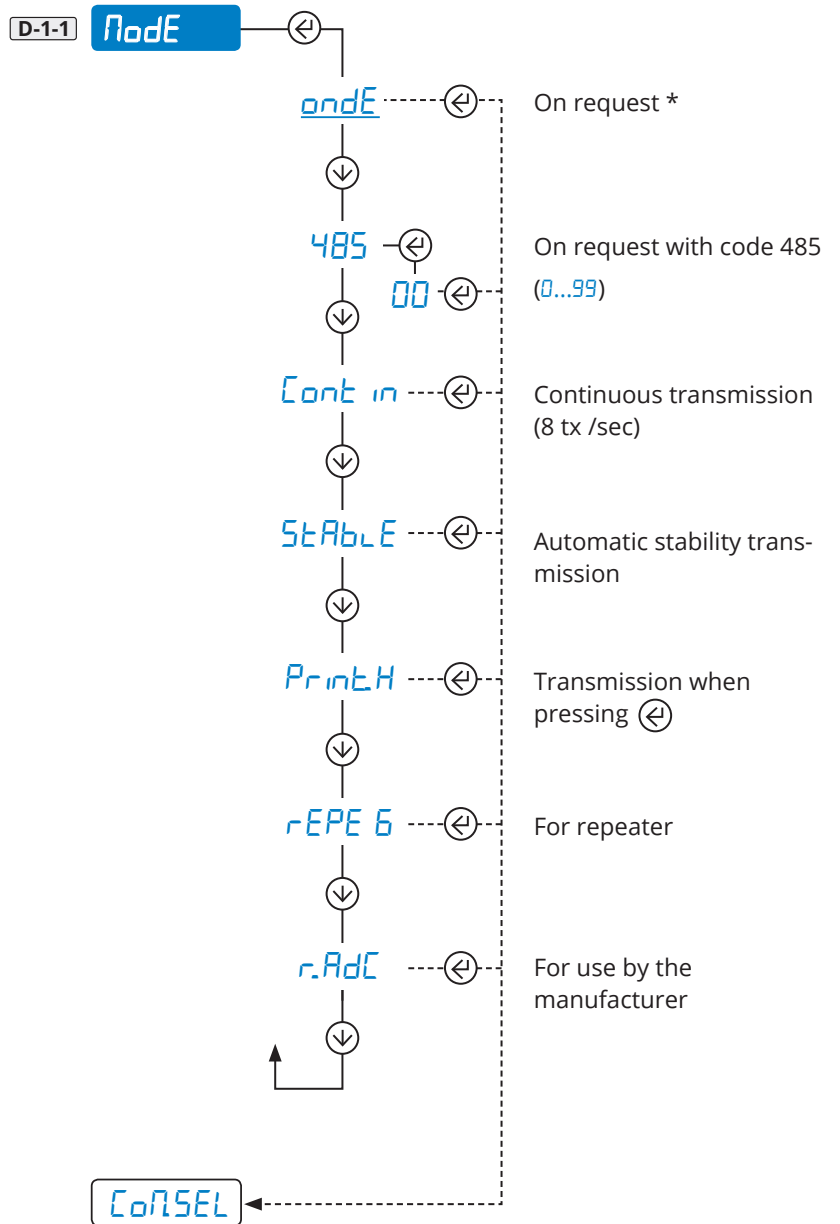

 * For communication strings and controls, see page 41 - 42.

 For the string selection, see step **D-3-1**.

MENU

How to enter

1. Off
2. On
- 3.

Page 8

How to browse

- =
- =
- =
- =

How to save and exit



Page 8

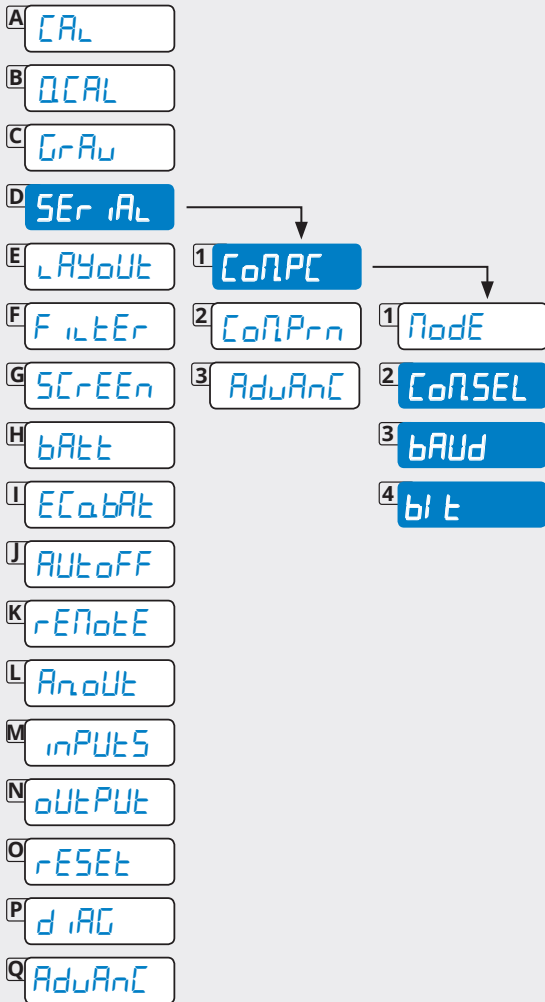

Selecting the COM port for connection with PC/PLC

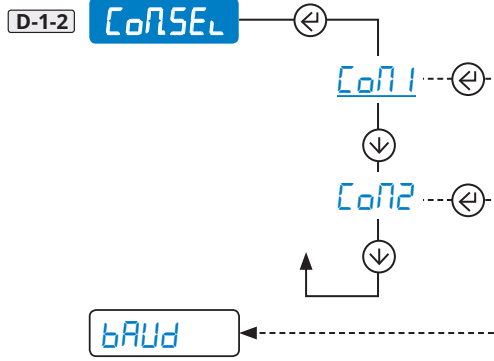

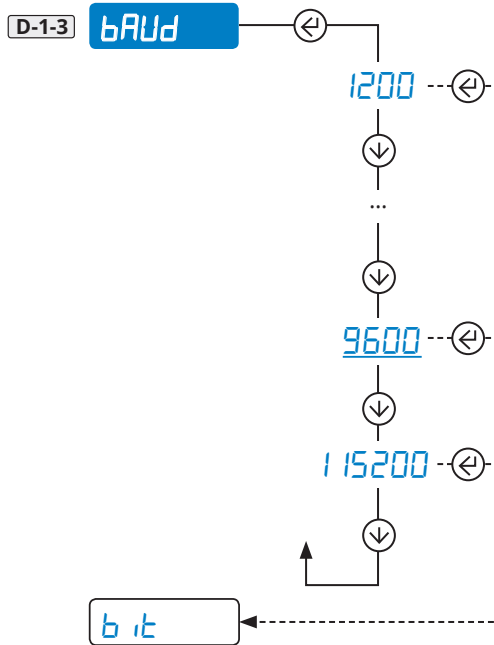

Communication speed (Baud rate)

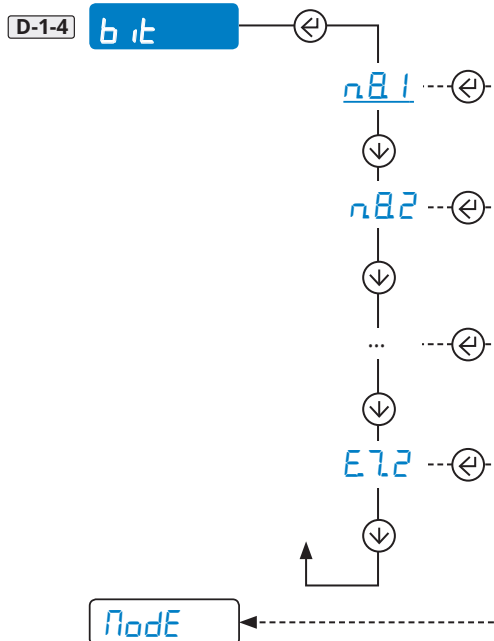

Configuration of the serial protocol









How to enter

1. Off 
2. On 
3. 

 Page 8

How to browse

-  = 
-  = 
-  = 
-  = 

How to save and exit



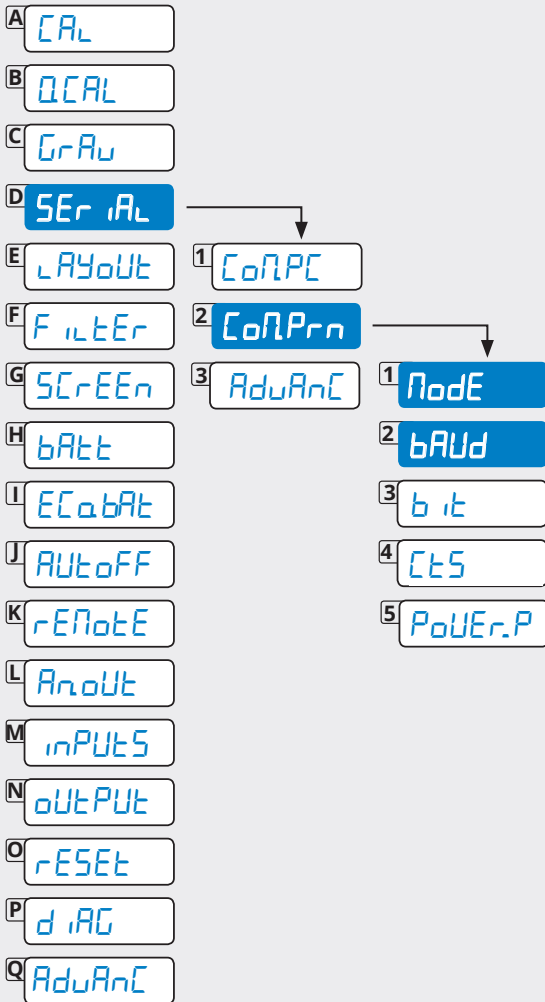

 Page 8

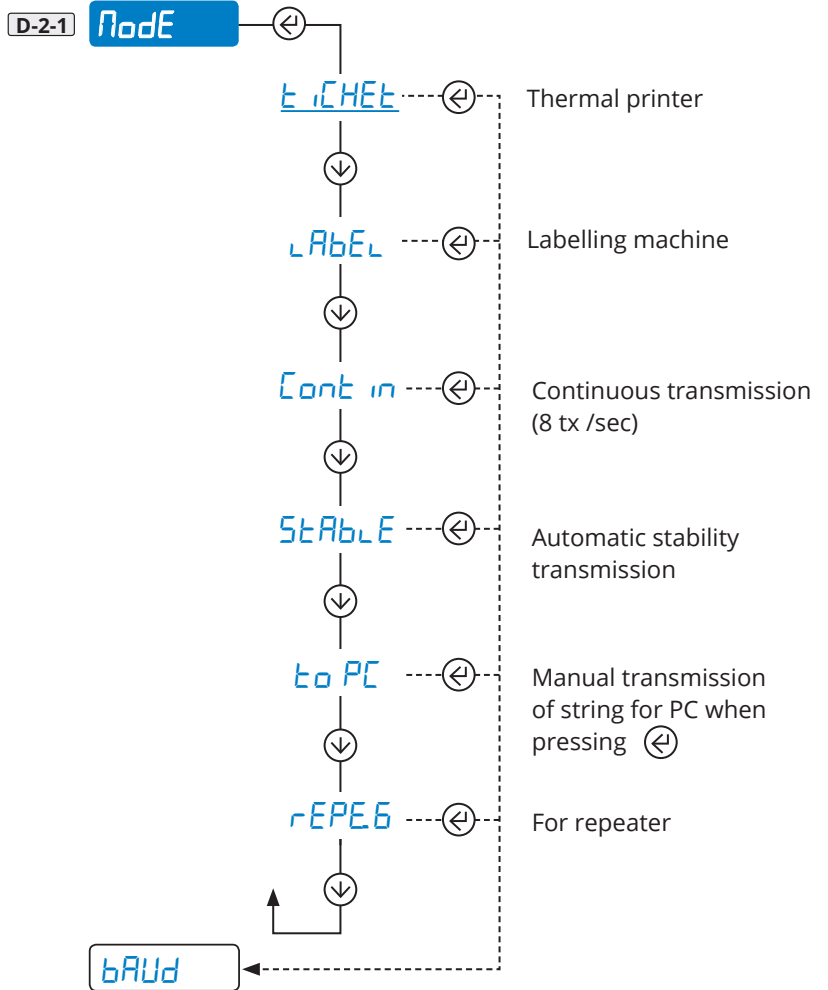

CoMPrn Communication with printer or repeater or PC 

Selection of the communication mode



 For communication strings and controls, see page 41 - 42.

Communication speed (Baud rate)

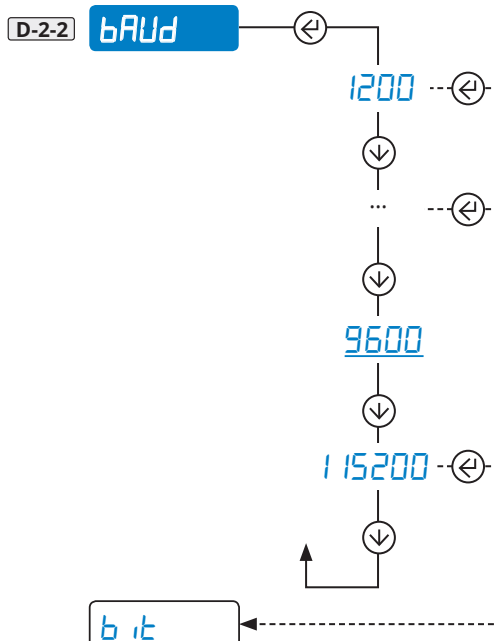

MENU

How to enter

1. Off
2. On
- 3.

Page 8

How to browse

- ↑ =
- ↓ =
- =
- ← =

How to save and exit



Page 8

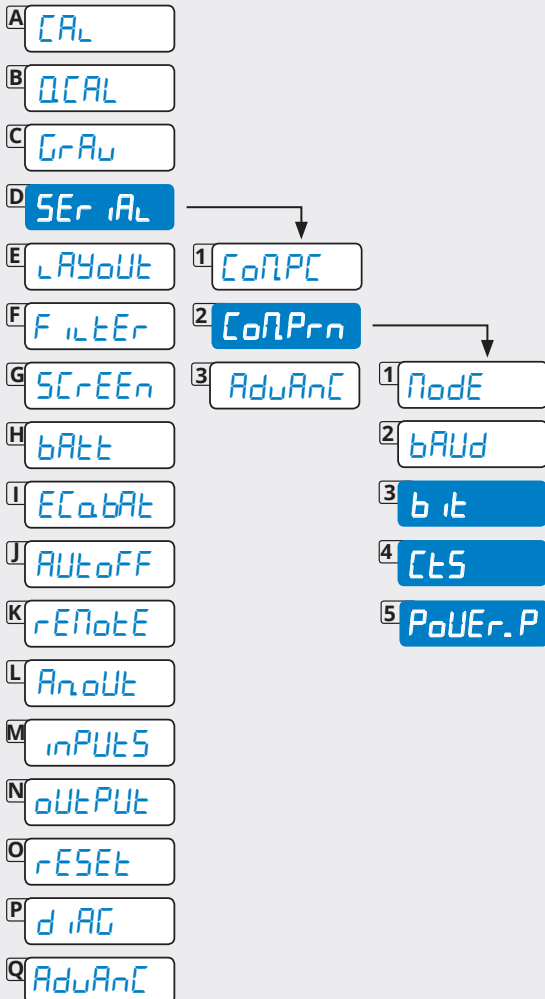

Configuration of the serial protocol

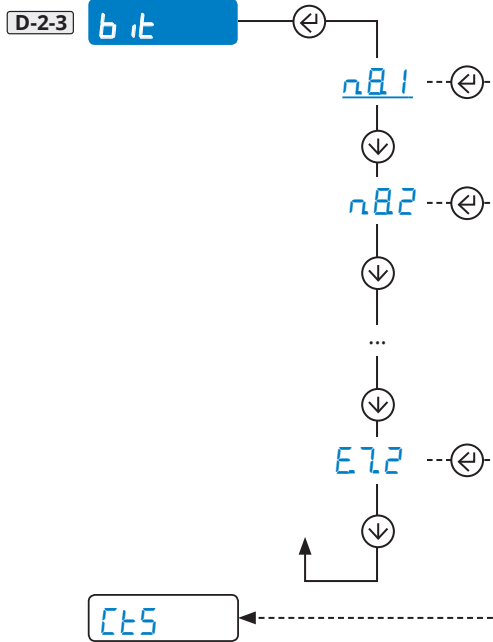

Printer control signal

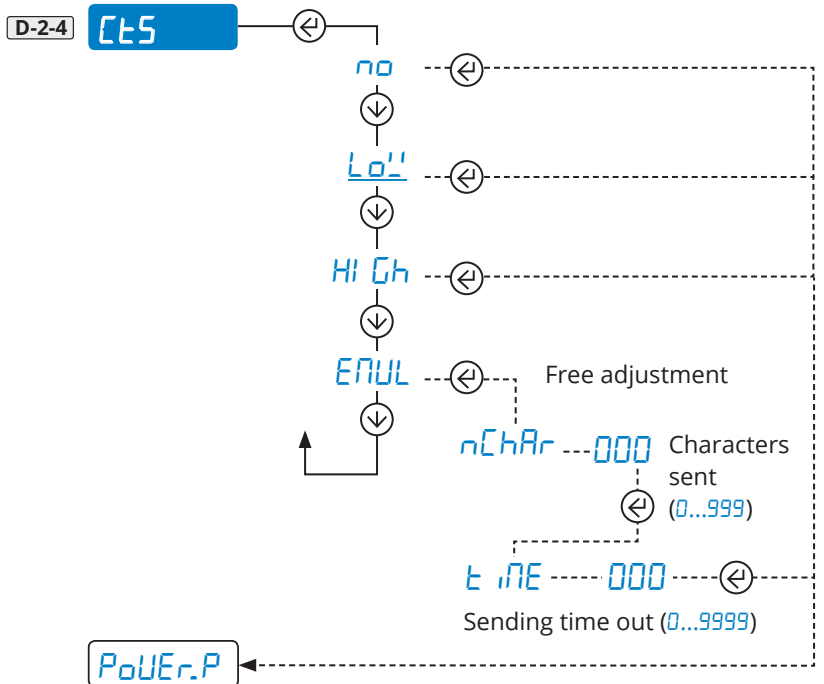

Printer power supply/Radio frequency module

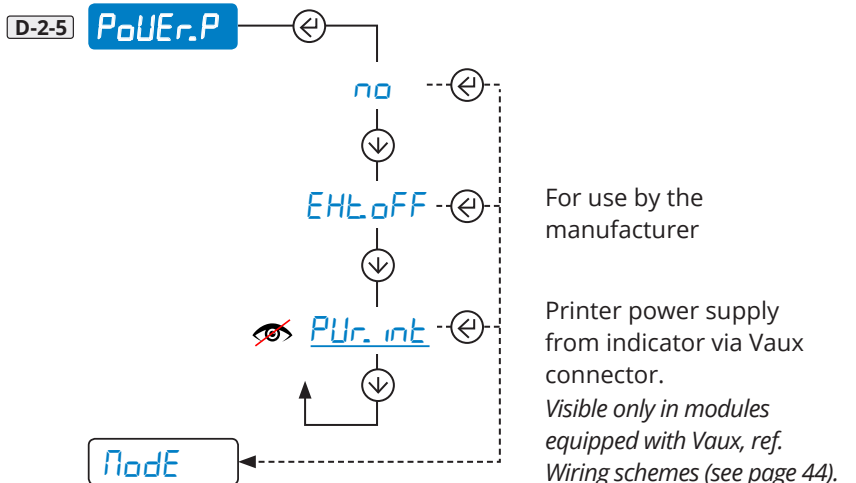

How to enter

- 1. Off
- 2. On
- 3.

Page 8

How to browse

- =
- =
- =
- =

How to save and exit



Page 8

- A CAL
- B QCAL
- C GrAV
- D **SEr iAL**
- E LAYoUt
- F Filter
- G SCrEEEn
- H bAtt
- I ECobAt
- J AUtoFF
- K rENotE
- L AnoUt
- M inPUtS
- N oUtPUt
- O rESEt
- P d iAG
- Q **AdvAnC**

1 CoMP

2 CoMPrn

3 **AdvAnC**

1 **ProtoC**

2 **rAd io**

3 **tLtL tL**

4 **tErn**

AdvAnC Advanced configurations

Communication protocol

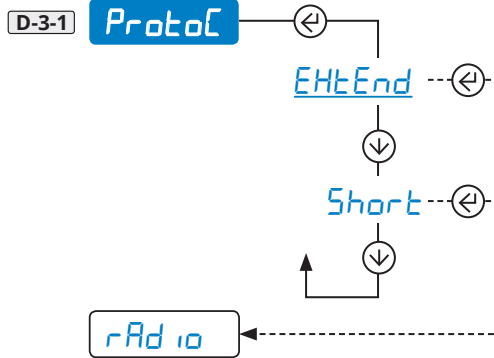

For communication strings and controls, see page 41 - 42.

Connection port of radio frequency module (for use by the manufacturer)

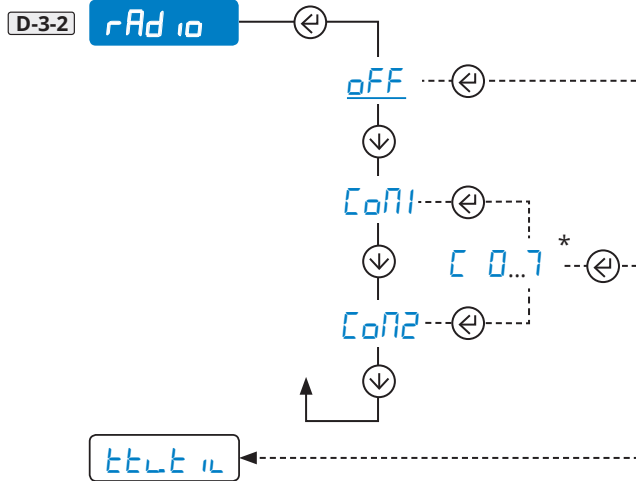

TTL port/Inclinometer activation (for use by the manufacturer)

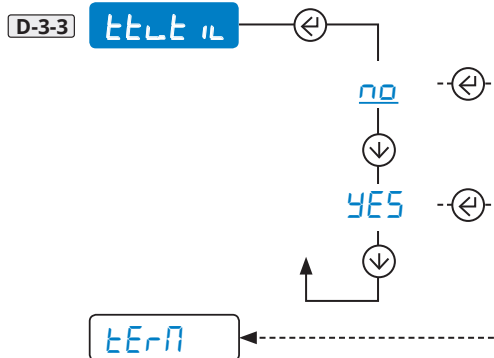

Closing character of each print line

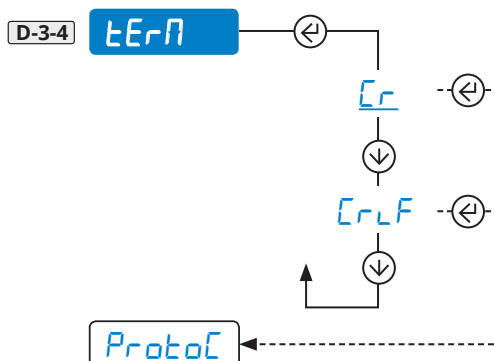



How to enter

- 1. Off
- 2. On
- 3.

Page 8

How to browse

- =
- =
- =
- =

How to save and exit



Page 8

- A
- B
- C
- D
- E
 - 1
 - 2
 - 3
 - 4
 - 5
 - 6
 - 7
 - 8
 - 9
 - 10
 - 11
 - 12
 - 13
 - 14
 - 15
 - 16
 - 17
 - 18

Parameters for receipt/label mode

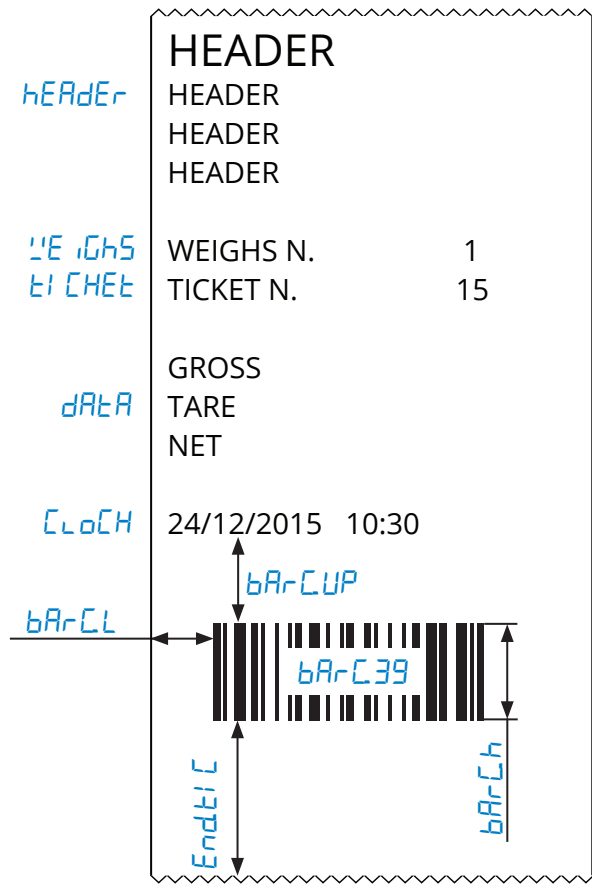

Additional parameters for label mode

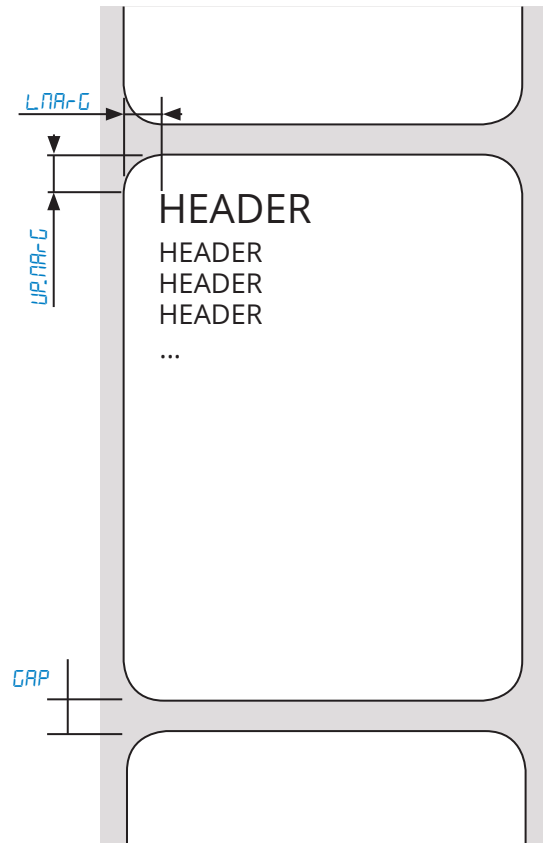

MENU

How to enter

1. Off
2. On
- 3.

Page 8

How to browse

- =
- =
- =
- =

How to save and exit



Page 8

A	CA _L			
B	QCAL			
C	GRA _W			
D	SEr iAL			
E	LAYoUt			
F	FiLteR	1	LANG	
G	SCrEEen	2	ChAr	
H	bAtt	3	hEAdER	1
I	ECobAtt	4	dAtA	2
J	AUtOoFF	5	UE iGHS	
K	rENotE	6	t iCHET	
L	ANoUt	7	CLoCH	
M	inPUtS	8	bARc39	
N	oUtPUt	9	bARcUP	
O	rESEt	10	bARcL	
P	d iAG	11	bARCh	
Q	AdUAnC	12	bARcDt	
		13	CoP iES	
		14	Endt iC	
		15	bl inE	
		16	LAbEL	
		17	LbSAUe	
		18	tEst	

Setting of the print language (iAL, EnG, dEUT, FrAn, ESPA, Ch inES)

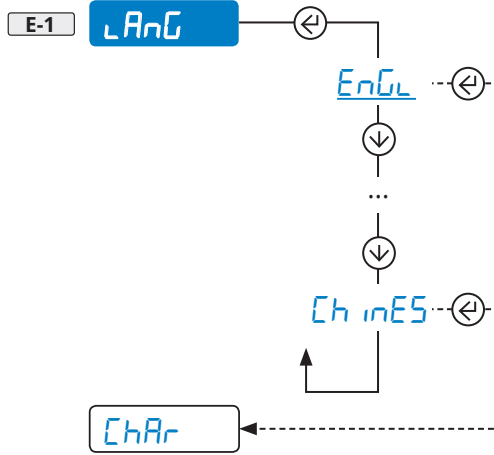

Character dimensions

E-2-1 ChAr 1

Main character

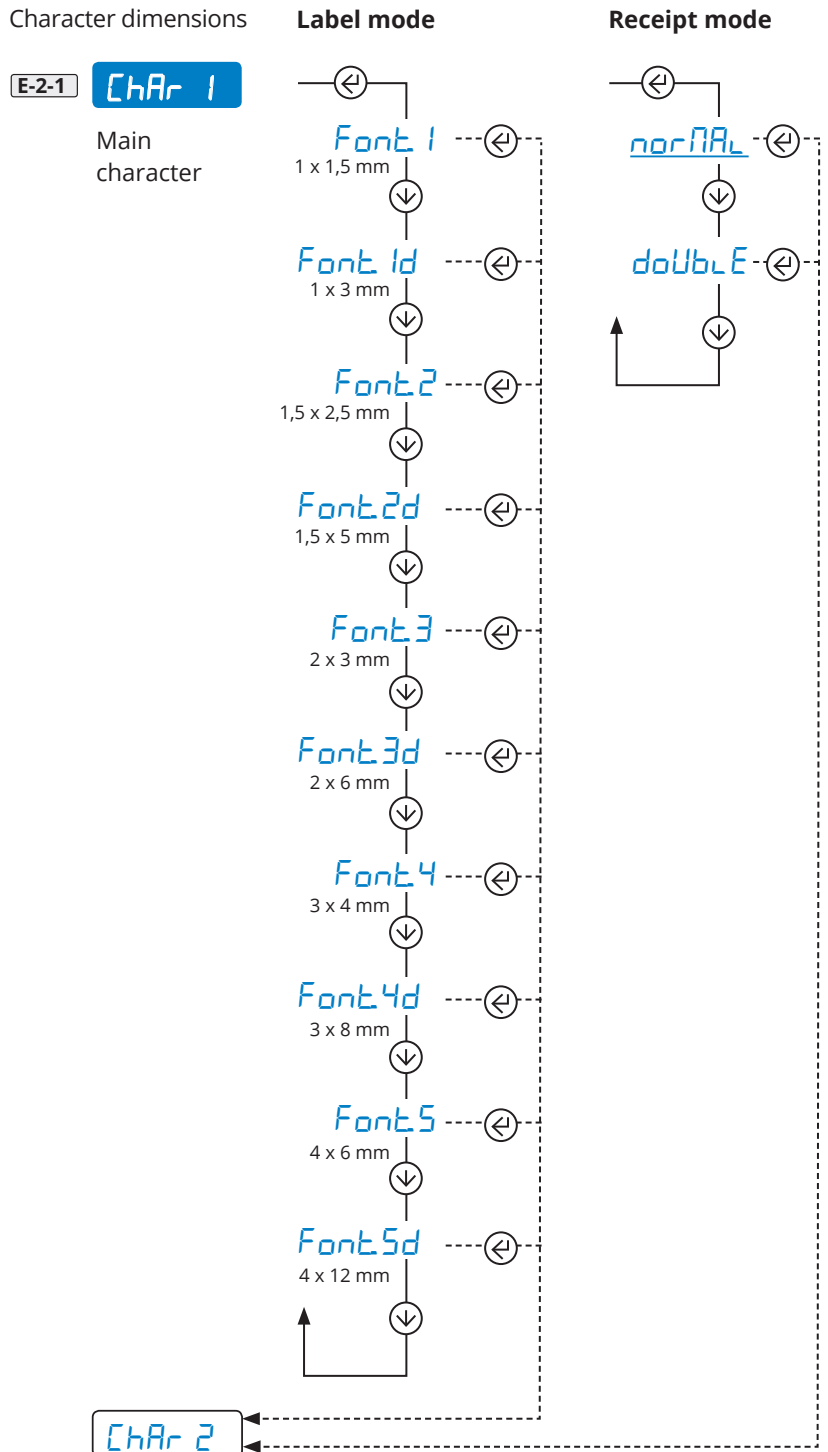

E-2-2 ChAr 2

See ChAr 1

How to enter

- Off
- On
-

Page 8

How to browse

- =
- =
- =
- =

How to save and exit



Page 8

A	CAL		
B	QCAL		
C	GRAV		
D	SERIAL		
E	LAYOUT		
F	FILTER	1	LANG
G	SCREEN	2	CHAR
H	BATT	3	HEADER
I	ECOBATT	4	DATA
J	AUTOFF	5	WEIGHTS
K	RESET	6	TARE
L	ANOUT	7	COUCH
M	INPUTS	8	BARC39
N	OUTPUT	9	BARCUP
O	RESET	10	BARCL
P	DIAG	11	BARCh
Q	ADUANC	12	BARCdt
		13	COPIES
		14	ENDTIC
		15	LINE
		16	LABEL
		17	LSAVE
		18	TEST

hEAdEr Print header



Enables header printing

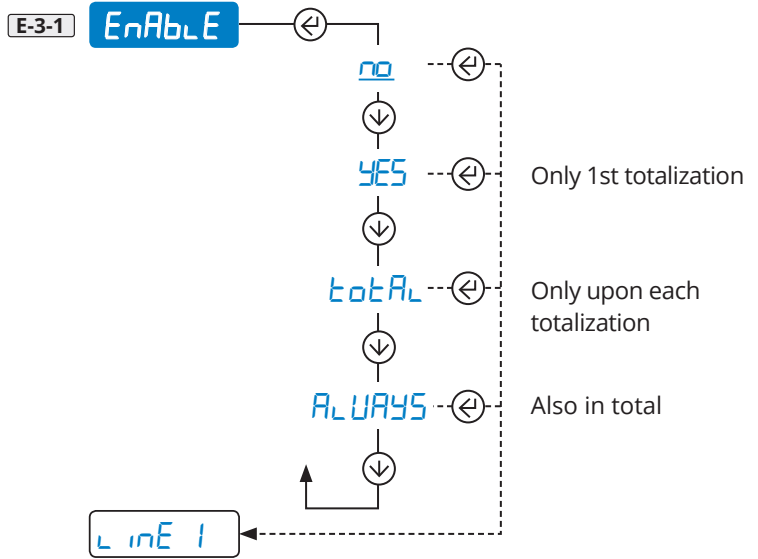

Contents of the header lines

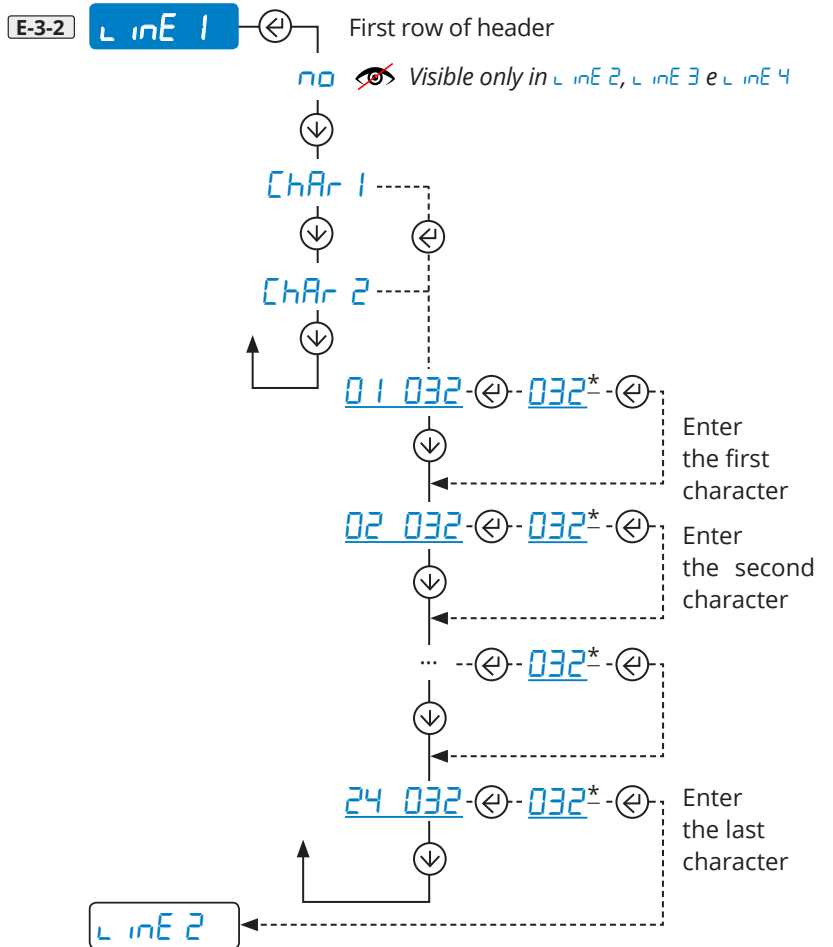

How to set the value



Repeat the operation to program LINE 2, LINE 3 and LINE 4. Select no to disable them.

MENU

How to enter

- Off
- On
-

Page 8

How to browse

- =
- =
- =
- =

How to save and exit



Page 8

- A CAL
- B QCAL
- C GRAV
- D SERIAL
- E **LAYOUT**
 - 1 LANG
 - 2 CHAR
 - 3 **HEADER**
 - 1 **ENABLE**
 - 2 **LINE 1**
 - 3 **LINE 2**
 - 4 **LINE 3**
 - 5 **LINE 4**
 - 7 CLOCH
 - 8 BARCL39
 - 9 BARCLUP
 - 10 BARCL
 - 11 BARCLH
 - 12 BARCLDT
 - 13 COPIES
 - 14 ENDTIC
 - 15 BLINE
 - 16 LABEL
 - 17 LABELS
 - 18 TEST
- F FILTER
- G SCREEN
- H BATT
- I ECABAT
- J AUTOFF
- K RESET
- L ANOUT
- M INPUTS
- N OUTPUT
- O RESET
- P DIAG
- Q ADVANC

How to print/delete the row being programmed:

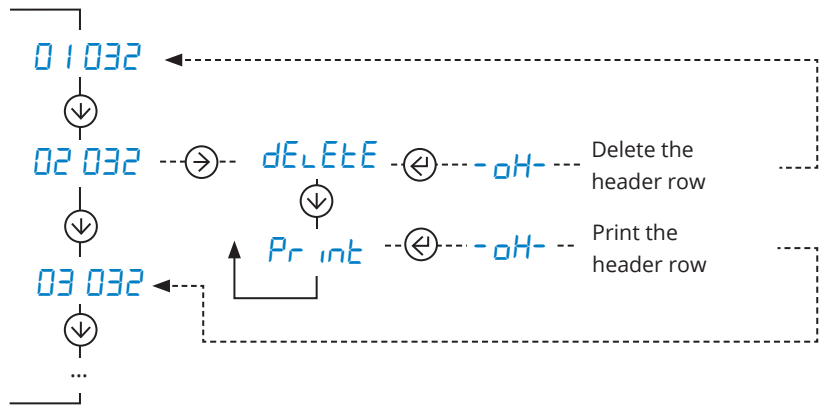

Programming example

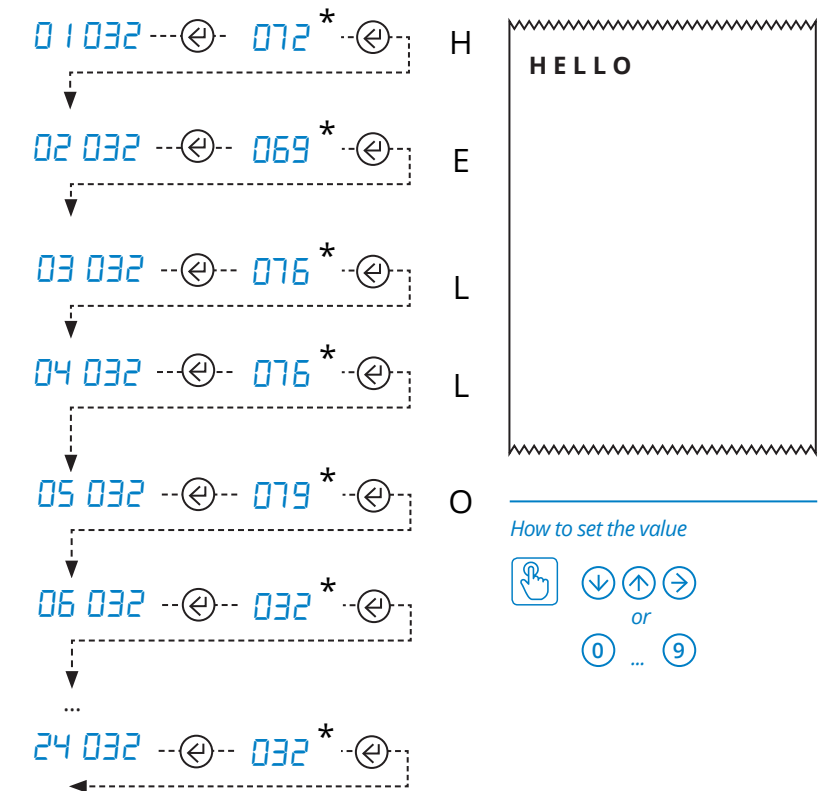

How to set the value



List of characters

(*)

32		47	/	62	>	77	M	92	\	107	k	122	z
33	!	48	0	63	?	78	N	93]	108	l	123	{
34	"	49	1	64	@	79	O	94	^	109	m	124	
35	#	50	2	65	A	80	P	95	_	110	n	125	}
36	\$	51	3	66	B	81	Q	96	'	111	o	126	~
37	%	52	4	67	C	82	R	97	a	112	p		
38	&	53	5	68	D	83	S	98	b	113	q		
39	'	54	6	69	E	84	T	99	c	114	r		
40	(55	7	70	F	85	U	100	d	115	s		
41)	56	8	71	G	86	V	101	e	116	t		
42	*	57	9	72	H	87	W	102	f	117	u		
43	+	58	:	73	I	88	X	103	g	118	v		
44	,	59	;	74	J	89	Y	104	h	119	w		
45	-	60	<	75	K	90	Z	105	i	120	x		
46	.	61	=	76	L	91	[106	j	121	y		

MENU

How to enter

- Off
- On
-

Page 8

How to browse

- =
- =
- =
- =

How to save and exit



Page 8

- A
- B
- C
- D
- E
 - 1
 - 2
 - 3
 - 4
 - 5
 - 6
 - 7
 - 8
 - 9
 - 10
 - 11
 - 12
 - 13
 - 14
 - 15
 - 16
 - 17
 - 18

Selection of the weight data

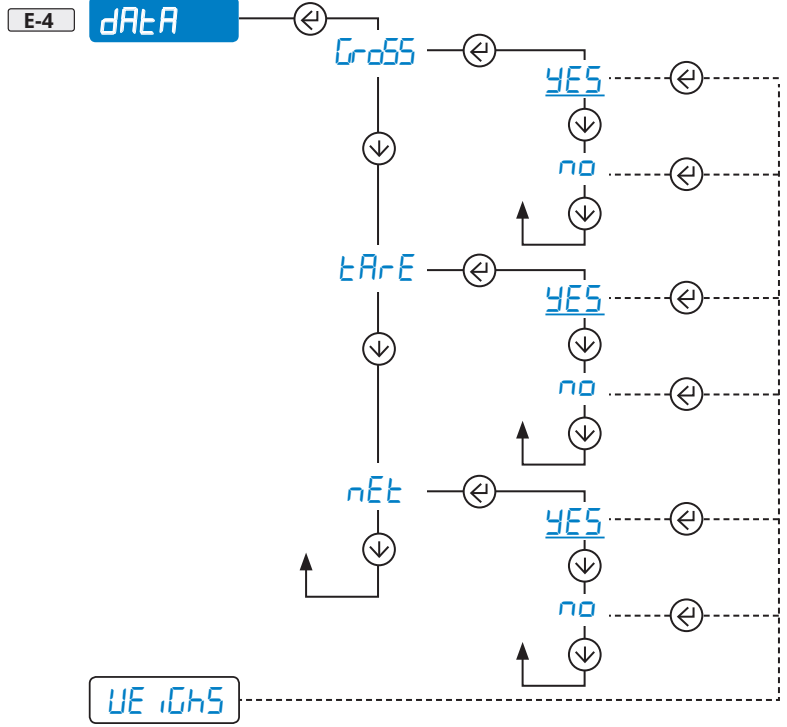

Progressive weighed

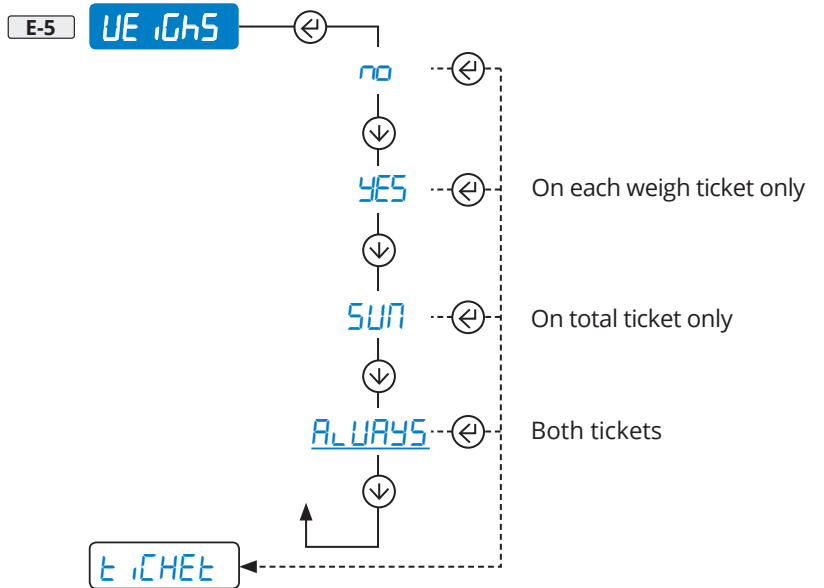

Receipt/label progressive

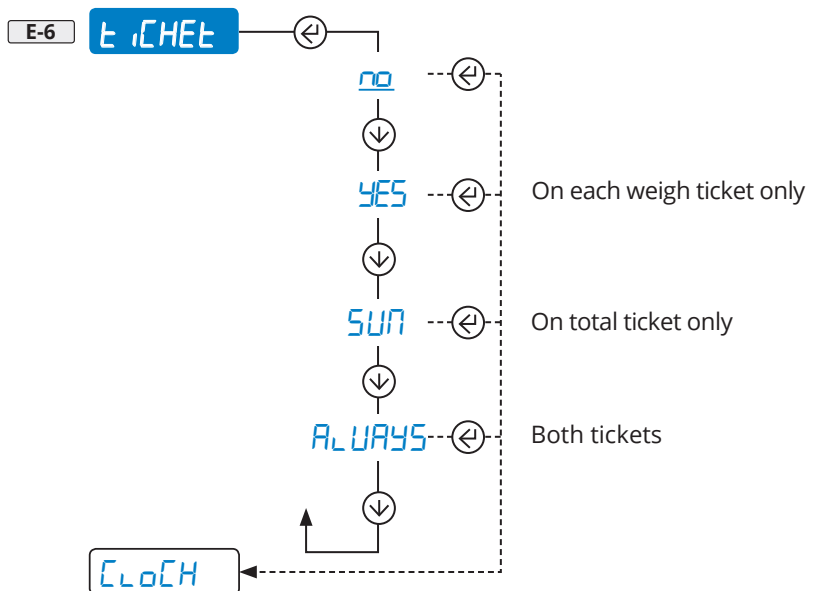

How to enter

- Off
- On
-

Page 8

How to browse

- =
- =
- =
- =

How to save and exit



Page 8

- A
- B
- C
- D
- E
 - 1
 - 2
 - 3
 - 4
 - 5
 - 6
 - 7
 - 8
 - 9
 - 10
 - 11
 - 12
 - 13
 - 14
 - 15
 - 16
 - 17
 - 18

Date and time

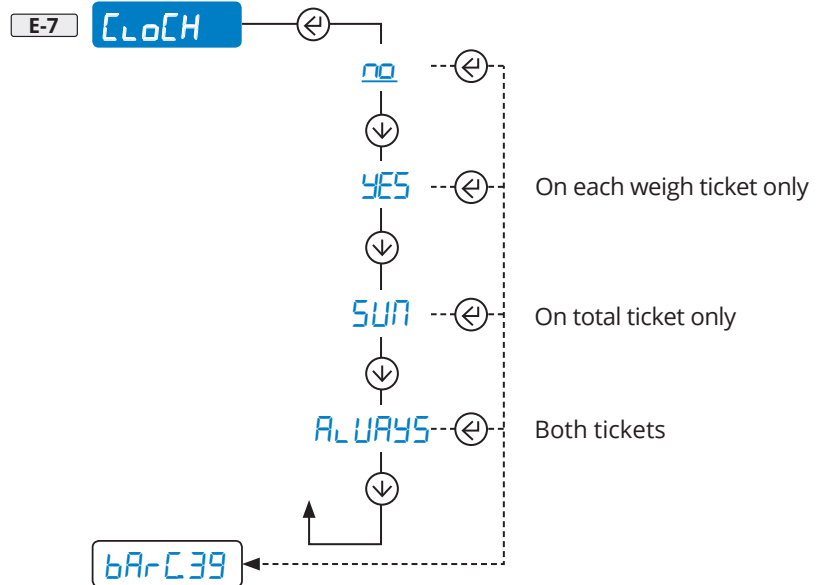

Bar code 39

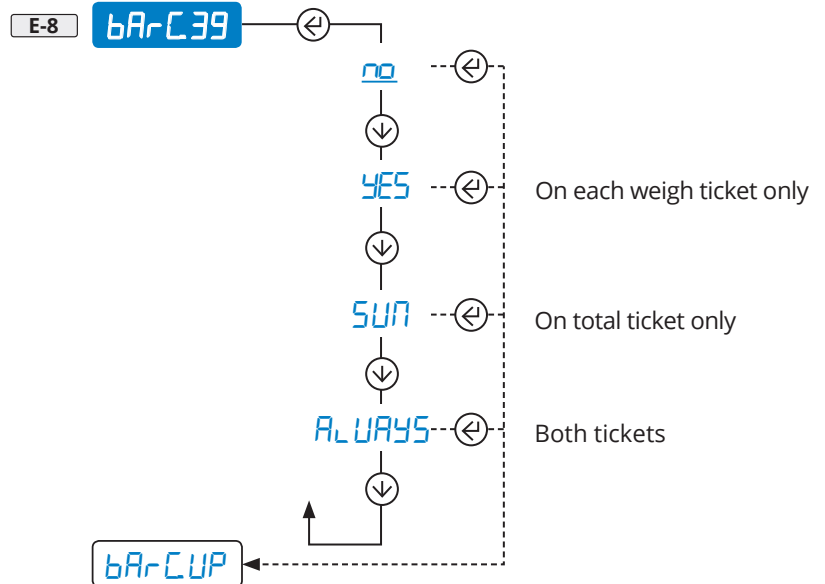

Barcode top margin (mm)

Visible only if bArC39 (E-8) is active

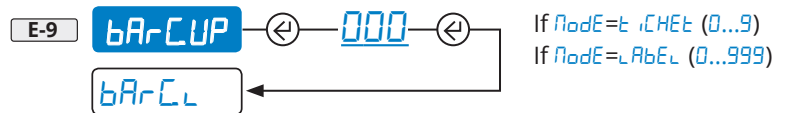

Barcode left margin (mm)

Visible only if bArC. 39 (E-8) is active

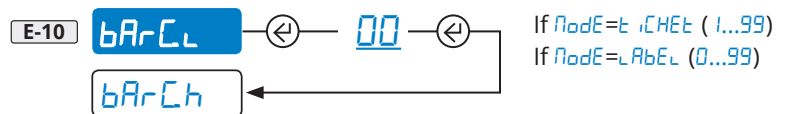

Barcode height (mm)

Visible only if bArC. 39 (E-8) is active

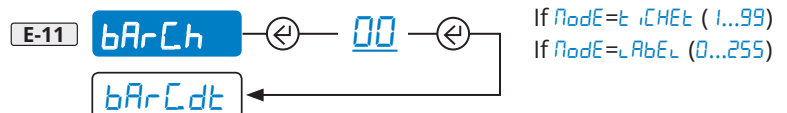

MENU

How to enter

1. Off
2. On
- 3.

Page 8

How to browse

- =
- =
- =
- =

How to save and exit



Page 8

- A
- B
- C
- D
- E
 - F
 - 1
 - G
 - 2
 - H
 - 3
 - I
 - 4
 - J
 - 5
 - K
 - 6
 - L
 - 7
 - M
 - 8
 - N
 - 9
 - O
 - 10
 - P
 - 11
 - Q
 - 12
 - 13
 - 14
 - 15
 - 16
 - 17
 - 18

Selection of the weight data

Visible only if **BARC39 (E-8)** is active

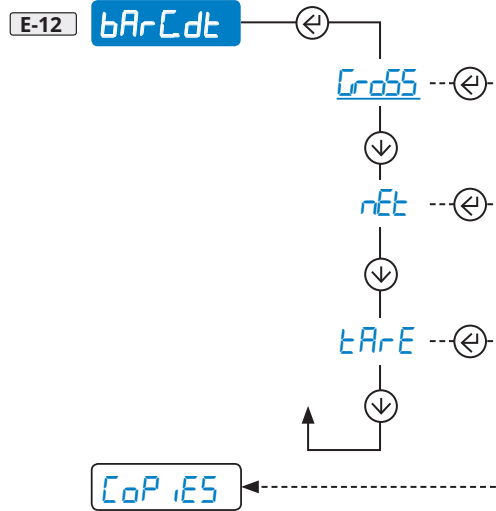

Multi-copy prints

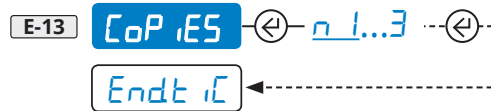

Paper outlet for end of label/receipt

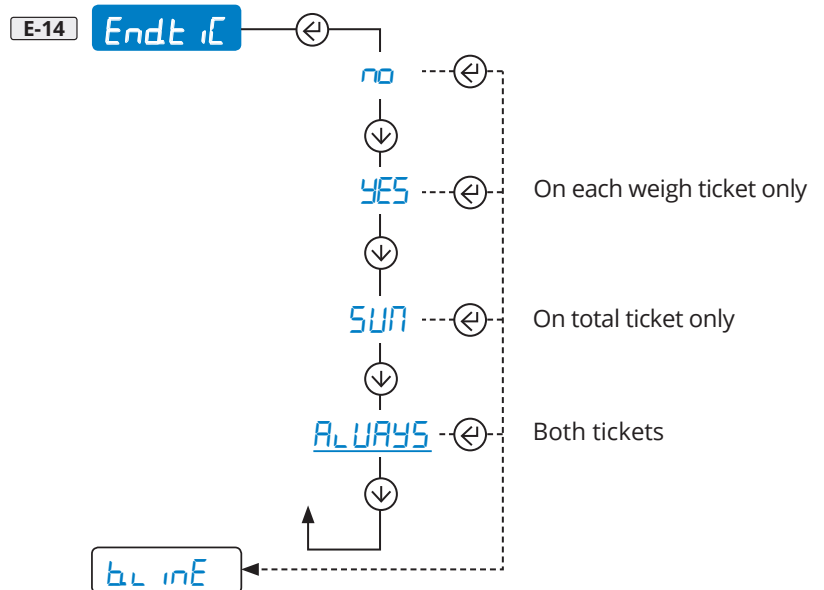

White preheating line of the print head (for thermal printer only)

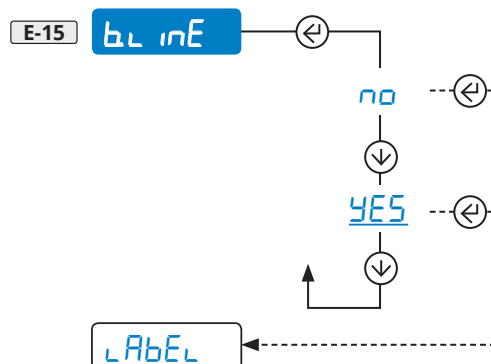

How to enter

1. Off
2. On
- 3.

Page 8

How to browse

- =
- =
- =
- =

How to save and exit



Page 8

- A **CALL**
- B **QCAL**
- C **GRAV**
- D **SEIAL**
- E **LAYOUT**
- F **FILTER**
- G **SCREEN**
- H **BATT**
- I **ECOBAT**
- J **AUTOFF**
- K **RENOTE**
- L **ANOUT**
- M **INPUTS**
- N **OUTPUT**
- O **RESET**
- P **DIAG**
- Q **ADVANC**
- 1 **LANG**
- 2 **CHAR**
- 3 **HEADER**
- 4 **DATA**
- 5 **WIDTHS**
- 6 **THEMET**
- 7 **LOCH**
- 8 **BARC39**
- 9 **BARCUP**
- 10 **BARCL**
- 11 **BARCh**
- 12 **BARCdt**
- 13 **COPIES**
- 14 **ENDtIC**
- 15 **BLINt**
- 16 **LABEL**
- 17 **LSAVE**
- 18 **TEST**

Label configuration

Visible only if $\text{ModE (D-2-1)} = \text{LABEL}$

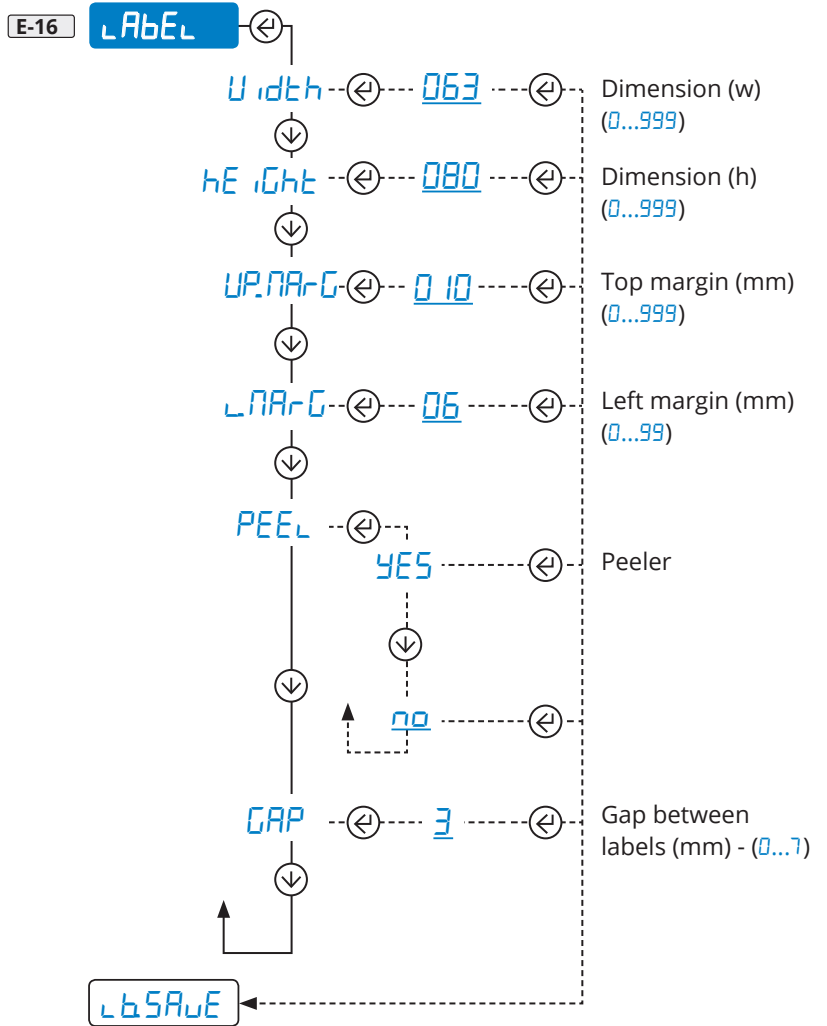

Saving of labels in the printer memory

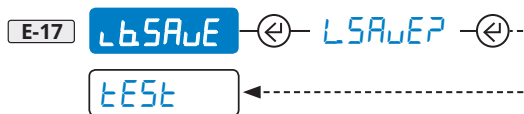

Visible only if $\text{ModE (D-2-1)} = \text{LABEL}$

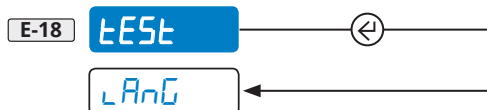

Saving of labels in the printer memory (for label mode only) and test print of ALL FORMATS









How to enter

- 1. Off 
- 2. On 
- 3. 

 Page 8

How to browse

-  = 
-  = 
-  = 
-  = 

How to save and exit





 Page 8

- A CAL
- B QCAL
- C CrAw
- D SEr iAL
- E LAYoUt
- F **Filter**
- G SCrEEr 1 StAnd0
- H bAtt ...
- I ECobAtt 4 StAnd3
- J AUtoFF 5 h iRES0
- K rENotE ...
- L Anot 12 h iRES7
- M inPUtS 13 dyn0
- N oUtPUt 16 dyn3
- O rESEt 17 SloU0
- P d iAG ...
- Q AduAnC 20 SloU3
- 21 doS0
- ... 24 doS3
- 25 r.AdC 0
- ... 28 r.AdC 5



Edits scale reactivity.
Useful to adjust the scale to your needs.

 With the approved instrument, you can select only some of the filters listed below (StAnd. 0...3, h iRES. 0 - 1, dyn. 0 - 1, SloU. 0 - 1).

 To weigh live animals, you must also activate the additional filter no iSE in AduAnC.

Premise:

The "0" represents minor filtering incidence.
Increasing the incidence give the weight more stability.
We recommend weighing several times, changing the incidence until you obtain the best compromise between reactivity and stability.

Table and floor scales and piece counters

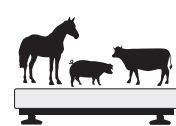
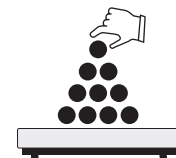
- F-1 **StAnd0** 
- ...
- F-4 **StAnd3**  



High precision scales

- F-5 **h iRES0** 
- ...
- F-12 **h iRES7**



Suspended and oscillating load weighing

- F-13 **dyn0** 
- ...
- F-16 **dyn3**

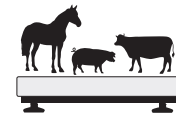
Liquid weighing, weighbridges and weighing with vibrations

- F-17 **SloU0** 
- ...
- F-20 **SloU3** 
- ...  

Metering, filling, level check and overloads

- F-21 **doS0** 
 - ...
 - F-24 **doS3** 
- Automatic Manual

Filter for specific applications for use by the manufacturer

- F-25 **r.AdC 0**
- ...
- F-28 **r.AdC 5**



MENU

How to enter

1. Off
2. On
- 3.

Page 8

How to browse

- ↑ =
- ↓ =
- =
- ← =

How to save and exit



Page 8

A CAL

B QCAL

C GrAu

D SEr iAL

E LAYoUt

F FilTEr

G SCrEEen

H bAtE

I ECobAt

J AUtoFF

K rENotE

L AnOUt

M inPUtS

N oUtPUt

O rESEt

P d iAG

Q AduAnC

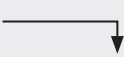

1 bAtE

2 br iGht

3 LoCH

4 CoLoUr

SCrEEen Adjusting the display



Backlighting

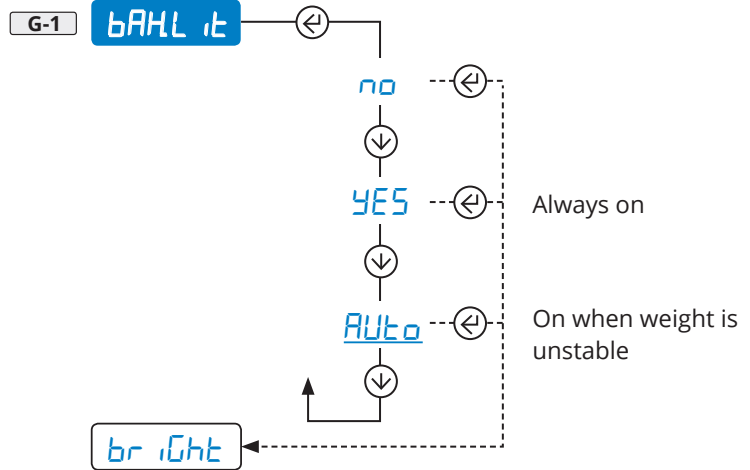

Brightness

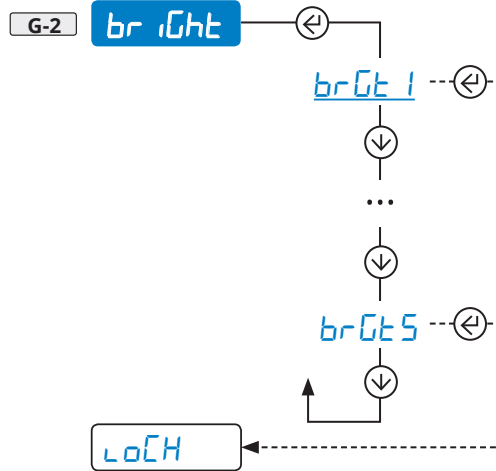

Display lock (for use by the manufacturer)

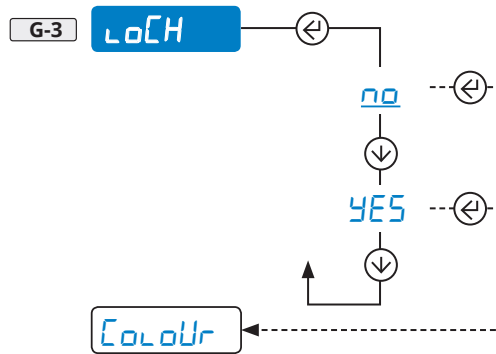

Backlighting colour

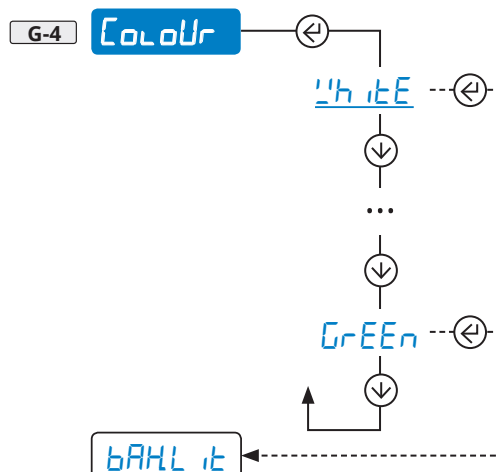

Only in version with color display.

MENU

How to enter

1. Off
2. On
- 3.

Page 8

How to browse

- =
 =
 =
 =

How to save and exit



Page 8

- A CAL
- B QCAL
- C CrAu
- D SEr iAL
- E LAYoUt
- F FiLteR
- G SCrEEr
- H **bAtT**
- I **ECobAt**
- J AUtoFF
- K rENotE
- L AnoUt
- M inPUtS
- N oUtPUt
- O rESEt
- P d iAG
- Q AduAnC

bAtT Power supply via battery

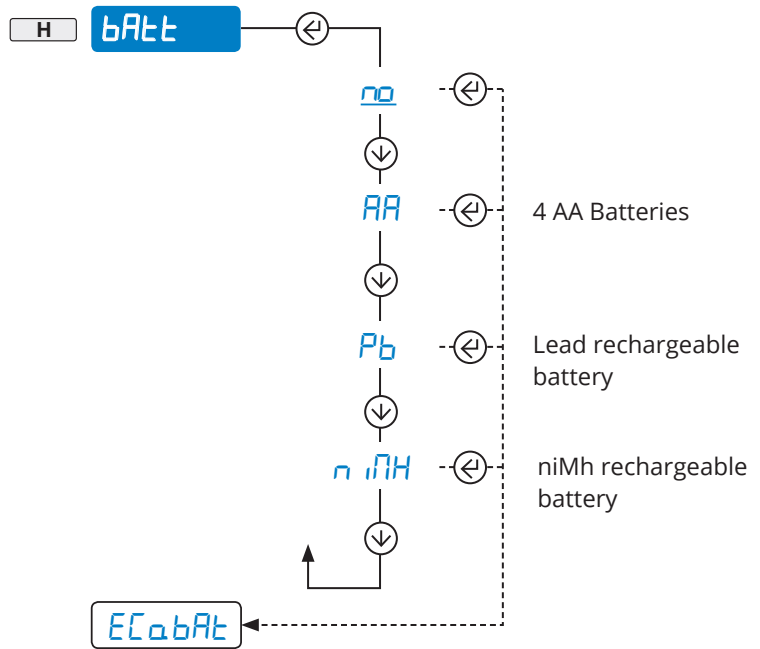

WARNING:
only use original rechargeable batteries.

ECobAt Energy saving for battery operation



Visible only if **bAtT** (H) is active

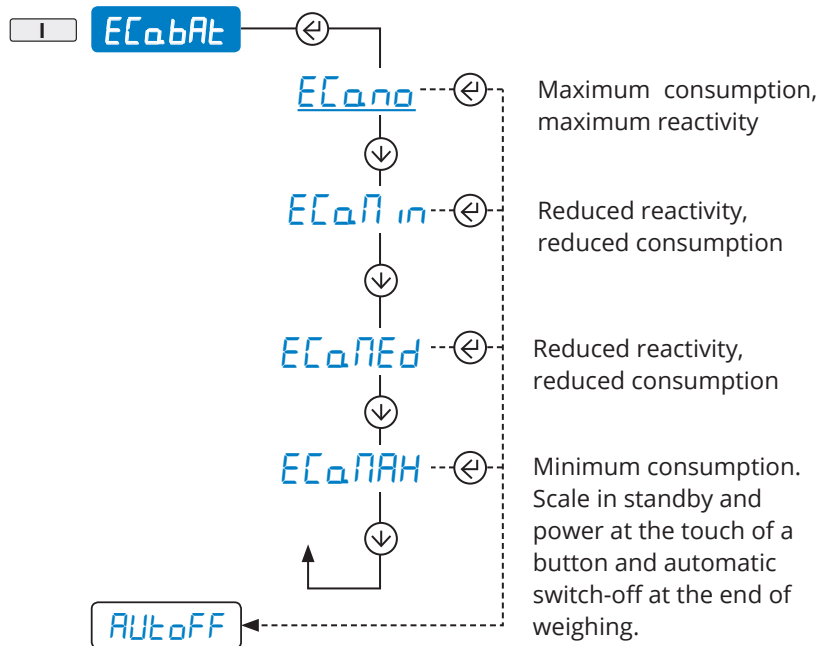

MENU

How to enter

1. Off
2. On
- 3.

Page 8

How to browse

- =
- =
- =
- =

How to save and exit



Page 8

- A CAL
- B QCAL
- C GRAV
- D SERIAL
- E LAYOUT
- F FILTER
- G SCREEN
- H BATT
- I ECABAT
- J **AUTOFF**
- K **REMOTE**
- L ANOUT
- M INPUTS
- N OUTPUT
- O RESET
- P DIAG
- Q ADVANC

AUTOFF Auto off

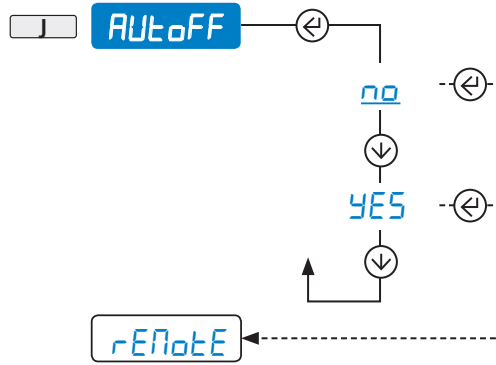

REMOTE Remote control

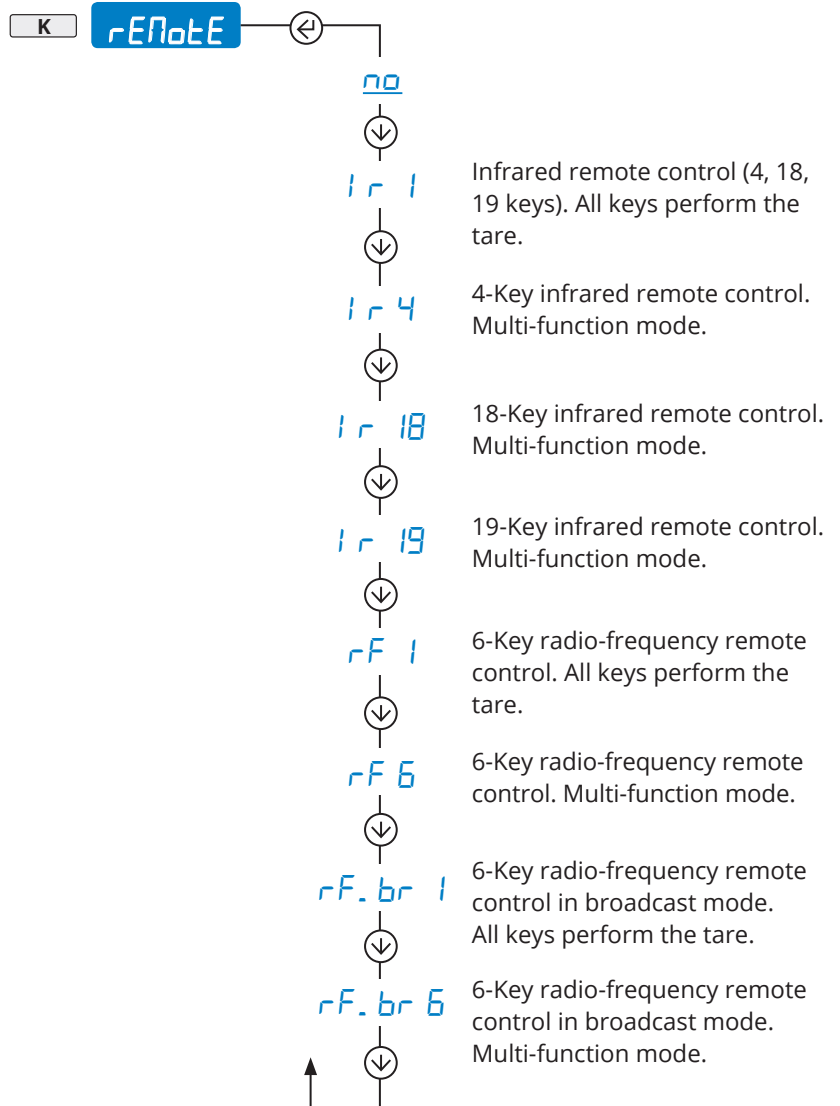

The broadcast mode allows sending the control to multiple scales simultaneously.



How to enter

1. Off
2. On
- 3.

Page 8

How to browse

- =
- =
- =
- =

How to save and exit



Page 8

- A CAL
- B QCAL
- C GrAu
- D SEr iAL
- E LAYoUt
- F Filter
- G SCrEEr
- H bAtE
- I ECobAt
- J AUtoFF
- K rENotE
- L **AnoUt**
 - 1 nEt
 - 2 PntUnd
 - 3 UGt 1
 - 4 Pnt 1
 - 5 UGt 2
 - 6 Pnt 2
 - 7 UGt 3
 - 8 Pnt 3
 - 9 Pntour
- M inPUtS
- N oUtPUt
- O rESEt
- P d iAG
- Q AduAnC

Visible only in the presence of optional analog board.

Operation proportional to the net/gross weight

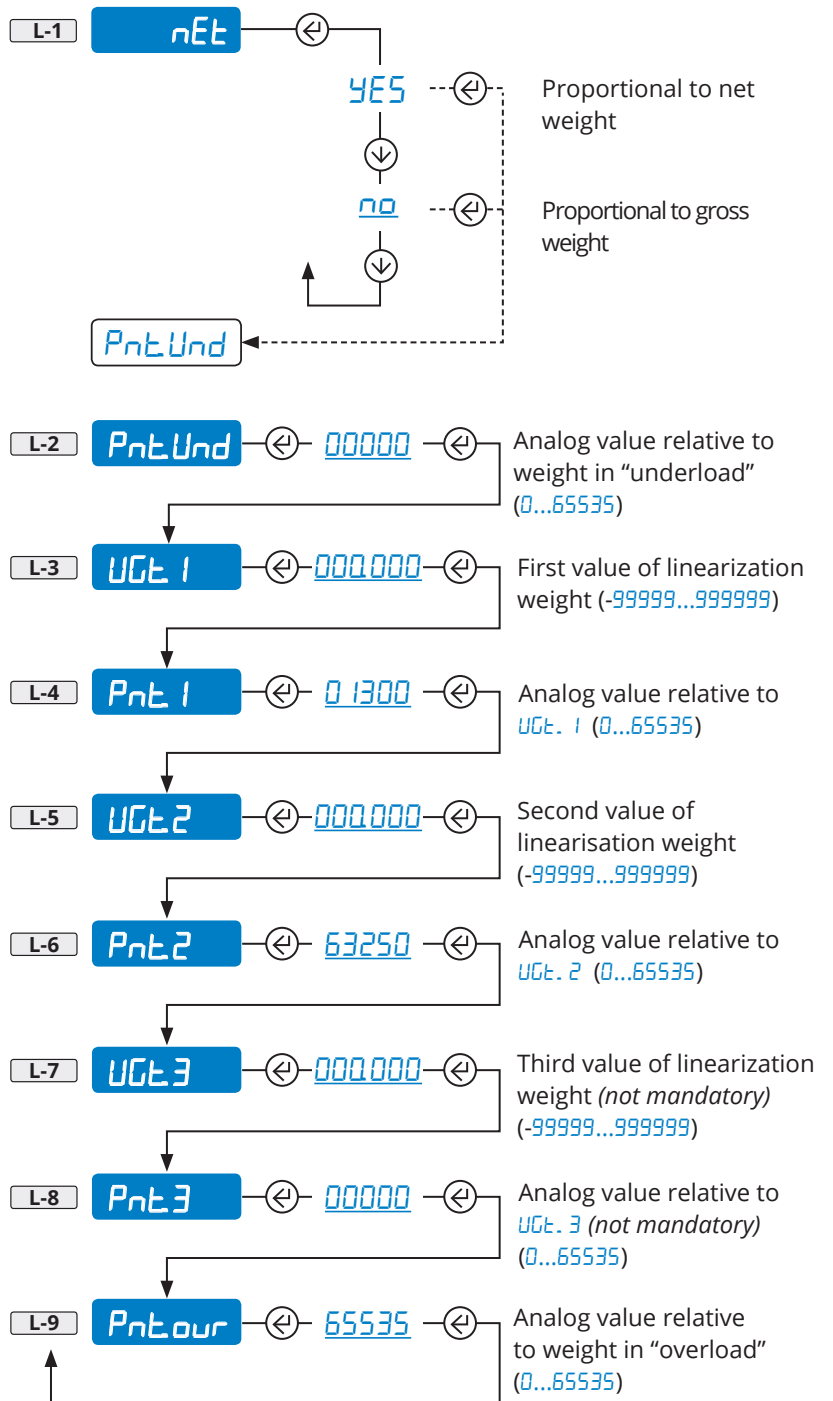

Thanks to the real-time upgrading of the output, using a tester you can check the value entered (see example page 30).

Value to be entered	Output volts	Output mA
1200	~ 0 V	~ 0 mA
11250		~ 4 mA
52200		~ 20 mA
62300	~ 10 V	

MENU

How to enter

1. Off
2. On
- 3.

Page 8

How to browse

- =
- =
- =
- =

How to save and exit



Page 8

- A CAL
 - B QCAL
 - C GrAu
 - D SEr iAL
 - E LAYoUt
 - F FiLteR
 - G SCrEEen
 - H bAtte
 - I ECabAt
 - J AUtoFF
 - K rENotE
 - L AnOUt
 - M inPUTS
 - N oUtPUt
 - O rESEt
 - P d iAG
 - Q AduAnC
- 1 nEt
 - 2 PntUnd
 - 3 UGt 1
 - 4 Pnt 1
 - 5 UGt 2
 - 6 Pnt 2
 - 7 UGt 3
 - 8 Pnt 3
 - 9 Pnt 4

Programming example:

We want to program a linearization point so that at 1,000kg the analog output supplies 10V.

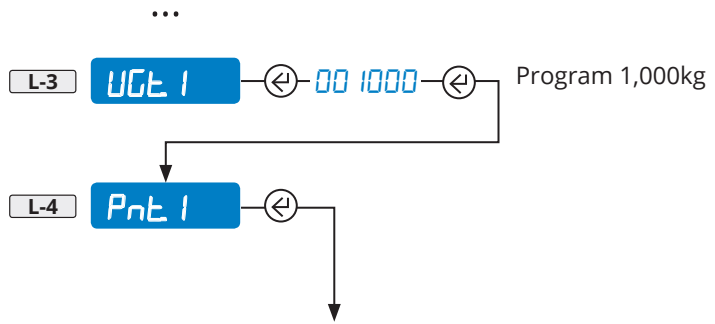

Enter **62300** (the reference value in the table) and check the analog output using a tester.

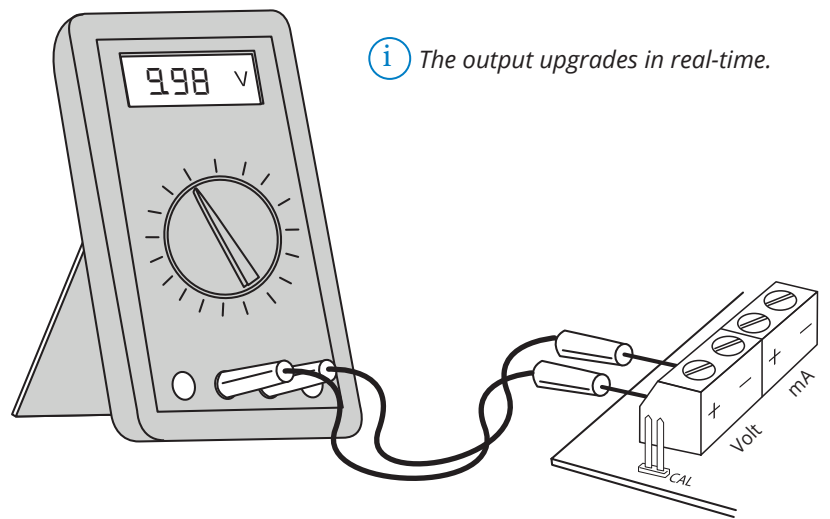

Adjust the analog output by increasing or decreasing the value. We recommend minimal changes of at least 10 points, (62310, 62320, 62330, etc.)

How to set the value

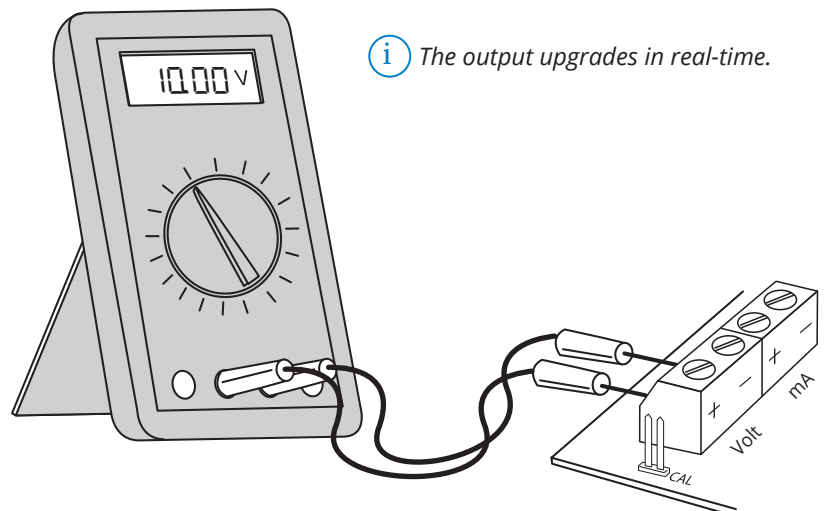

Once the desired adjustment has been made, confirm the value with

MENU

How to enter

1. Off
2. On
- 3.

Page 8

How to browse

- =
- =
- =
- =

How to save and exit



Page 8

- A CAL
 - B QCAL
 - C GrAV
 - D SEr iAL
 - E LAYoUt
 - F FiLTER
 - G SCrEEEn
 - H bAtt
 - I ECobAtt
 - J AUtoFF
 - K rENotE
 - L AnoUt
 - M **inPUtS**
 - N oUtPUt
 - O rESEt
 - P d iAG
 - Q AduAnC
- 1 **inP.b 1**
 - 2 **inP.b 2**
 - 3 **inP.b 3**
 - 4 **inP.b 4**

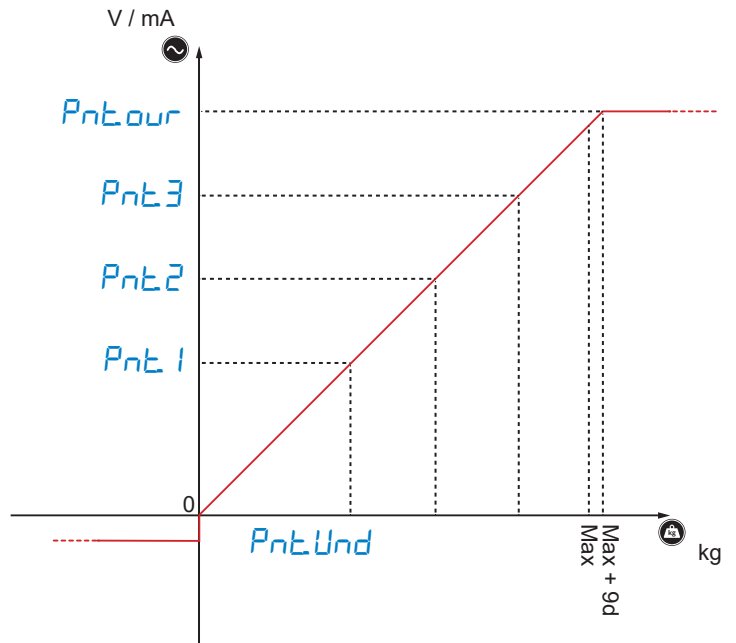

inPUtS Digital inputs



Visible only in the presence of optional inputs/outputs electronic board.

Input 1 configuration

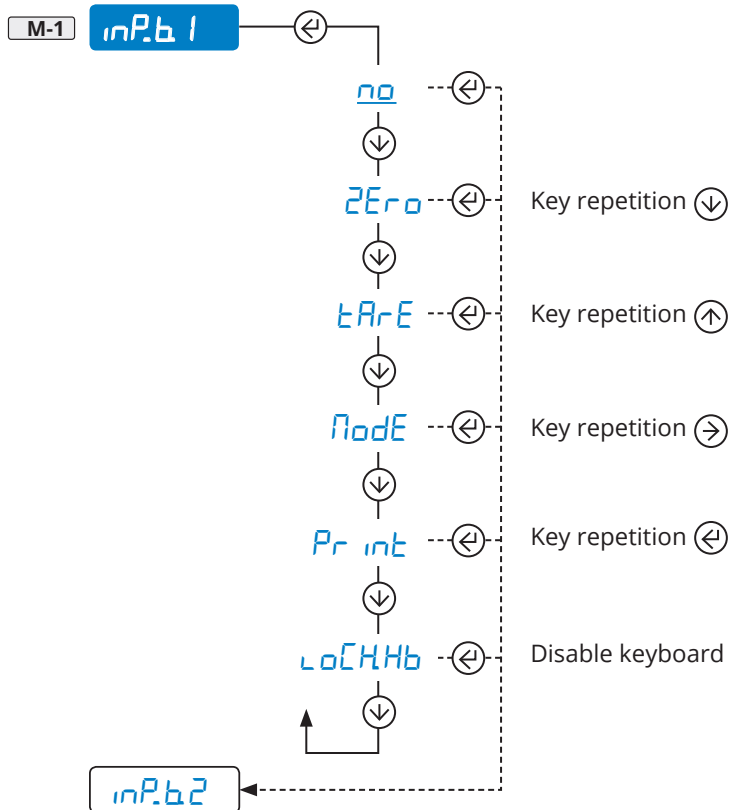

Repeat the same operation for inP.b 2, inP.b 3 e inP.b 4.

How to enter

1. Off
2. On
- 3.

Page 8

How to browse

- ↑ =
- ↓ =
- =
- ← =

How to save and exit



Page 8

A CAL

B QCAL

C GrAV

D SEr iAL

E LAYout

F iLteR

G SCrEEen

H bAtte

I ECabAt

J AUtoFF

K rENotE

L Anout

M inPUTS

N oUtPUt

O rESEt

P d iAG

Q AdvAnC

1 rELb.1

2 rELb.2

3 rELb.3

4 rELb.4

1 FUnct

2 ModE

3 d irEct

4 h iStEr



Visible only in the presence of optional inputs/outputs electronic board.

Operation on net weight, gross weight or dosage

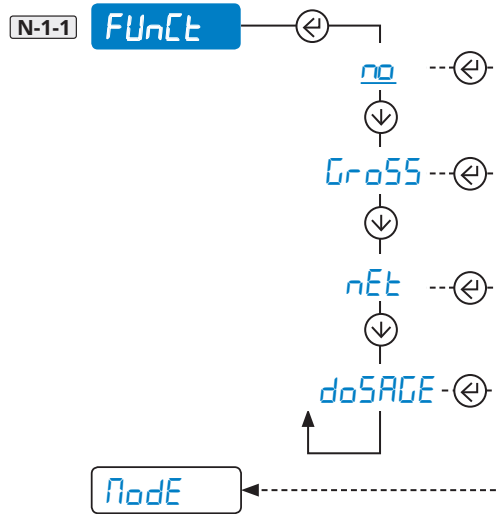

For dosage / filling:

- Start the doSAGE mode
- Set the UnlOCH unladen weight.

The output is activated only after having set the unladen weight of the container (by key or via external button) and is turned off once the set target (setpoint) has been achieved. To perform fills at two speeds, you must programme two outputs in doSAGE mode.

Normally open (n.o.) or closed (n.c.) operation

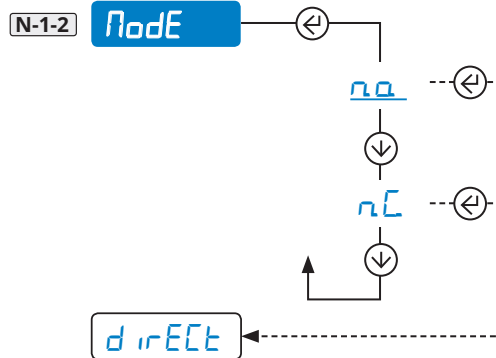

Output activation mode

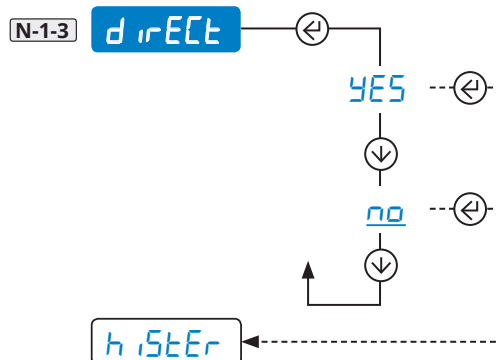

Direct, when weight is table or unstable

Only when weight is stable

Double threshold operation

(activation weight threshold ≠ from output deactivation weight threshold)

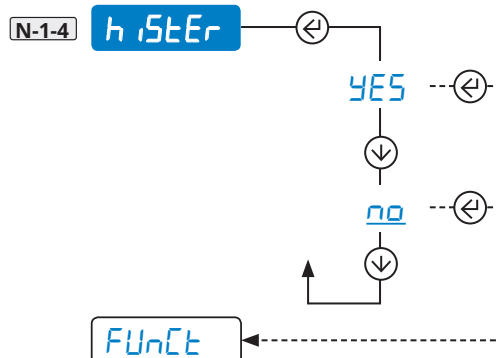

Operation:

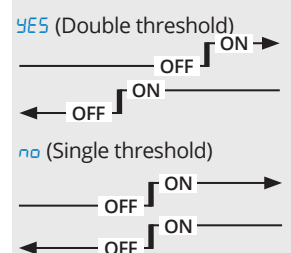

Repeat the same operation for rELb2, rELb3 and rELb4.



MENU

How to enter

1. Off
2. On
- 3.

Page 8

How to browse

- =
- =
- =
- =

How to save and exit



Page 8

A CAL

B QCAL

C CrAw

D SEr iAL

E LAYoUt

F FilteR

G SCrEEr

H bAtte

I ECabAt

J AUtoFF

K rENotE

L AnOUt

M inPUtS

N oUtPUt

O rESEt

P d iAG

Q AduAnC

1 AdCUu

2 d iSP_LA

3 HEYb

4 CtS

5 oUtPUt

6 inPUtS

7 AnOUt

8 SEr.nUN

9 PrCUEr

10 d iu int

11 AdCPnt

12 bEtAdC

13 PUAdC

14 SEr iAL

rESEt Factory configuration reset

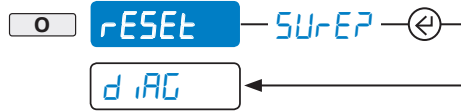

Function resetting the factory configurations while maintaining the calibration in the memory unchanged.

d iAG Diagnostics



P-1 AdCUu

Converter: Check of input signal in μV . In case of more equalised channels, press or to examine all the selected channels.

P-2 d iSP_LA

Display: Integrity check of all segments and icons.

P-3 HEYb

Keyboard: Press any key to verify its correct operation, with beep and code on display.

P-4 CtS

CTS: Check of status of the control signal from the printer.

P-5 oUtPUt

Optional digital outputs: Check the activation and deactivation of each contact.

Example: oUt 1 activates output 1. Press to select the next output.

WARNING: before entering the oUtPUt pitch, verify that the activation of the output does not cause dangerous conditions for people, animals or property.

P-6 inPUtS

Optional digital inputs: Check the activation and deactivation of each input.

Example: iN 1-0 input not active

Example: iN 1-1 input active

Press to select the next input.

P-7 AnOUt

Analog output: Enter the digital value and using a tester check the response of the analog output.

P-8 SEr.nUN

Serial number of the scale.

P-9 PrCUEr

Hardware revision (e.g. rEu 5) followed by software version (e.g. 040000).

P-10 d iu int

For use by the manufacturer.

P-11 AdCPnt

For use by the manufacturer.

P-12 bEtAdC

For use by the manufacturer.

P-13 PUAdC

For use by the manufacturer.

P-14 SEr iAL

For use by the manufacturer.



MENU

How to enter

1. Off
2. On
- 3.

Page 8

How to browse

- =
- =
- =
- =

How to save and exit



Page 8

- A CAL
- B QCAL
- C CrAu
- D SEr iAL
- E LAYoUt
- F Filter
- G SCrEEr
- H bAtt
- I ECabAt
- J AUtoFF
- K rENotE
- L AnoUt
- M inPUtS
- N oUtPUt
- O rESEt
- P d iAG
- Q AduAnC

- 1 CALPAR
- 2 EQUALP
- 3 CALAdu
- 4 no iSE
- 5 NEtroL
- 6 HEYb
- 7 t iLt
- 8 rEACt
- 9 LoCHAb
- 10 AL iB iR
- 11 P inTEC
- 12 P inUSE
- 13 dFLtT



Calibration parameters

Configuration of the decimal point (0...3)

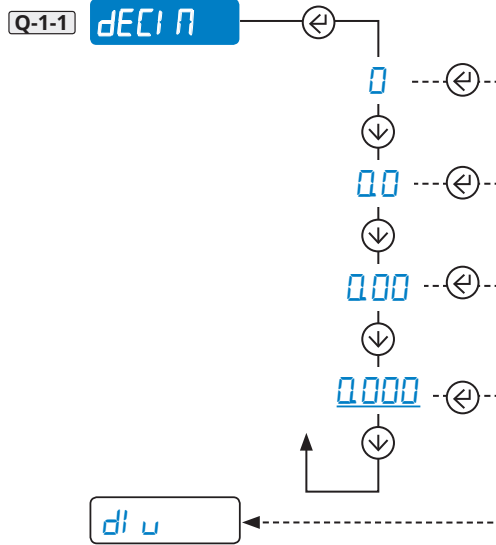

Reading division

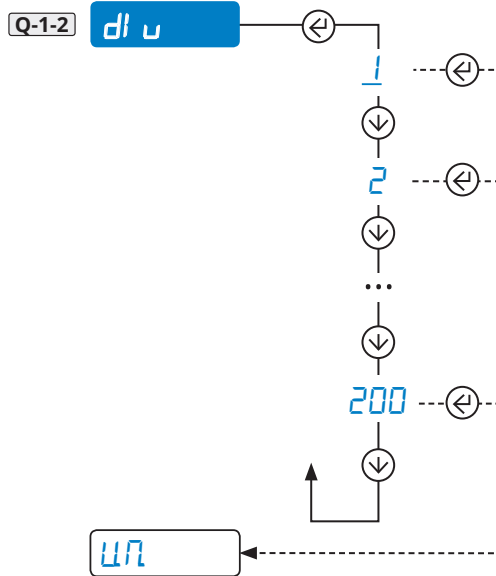

Unit of measure

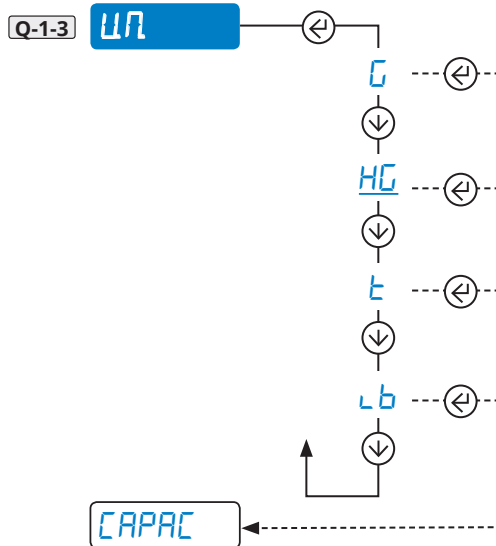

MENU

How to enter	How to browse	How to save and exit
1. Off	↑ =	 Page 8
2. On	↓ =	
3.	→ =	
Page 8	← =	

A CAL

B QCAL

C CrAU

D SEr iAL

E LAYoUt

F FilteR

G SCrEEn

H bAtte

I ECobAt

J AUtoFF

K rENotE

L AnOUt

M inPUtS

N oUtPUt

O rESEt

P d iAG

Q AdUAnC

1 CALPAR

2 EQUALP

3 CALAdU

4 no iSE

5 NEtrol

6 HEYb

7 t iLte

8 rEAct

9 LoCHHb

10 AL iB iR

11 P inTEC

12 P inUSE

13 dFLtE

1 dEC iN

2 di u

3 UN

4 rAnGE 1

5 rAnGE 2

6 rAnGE 3

7 EQUAL

8 nCHAN

Scale capacity: Set Max or Range 1 (Max range = 800000)

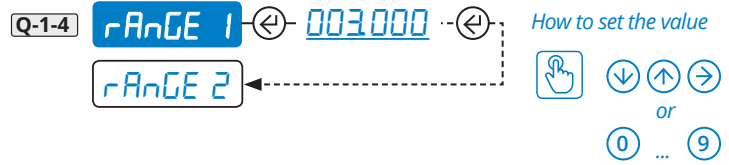

Range 2

For multirange scales, set the second weighing range.

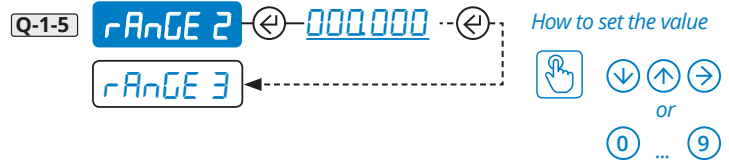

Range 3

For multirange scales, set the third weighing range.

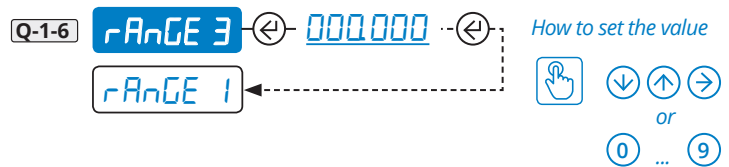

Example of multirange configuration at 1500/3000 kg, division 0.5/1 kg.

Set: $dEC i = 00$
 $di u = 5$
 $rAnGE 1 = 15000$
 $rAnGE 2 = 30000$

Equalization function

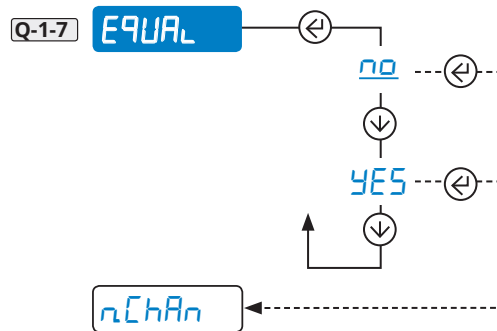

Connection diagram on page 7.
 Equalization procedure on page 36.

Equalized analog channels

Visible only if EQUAL (Q-1-7) = YES

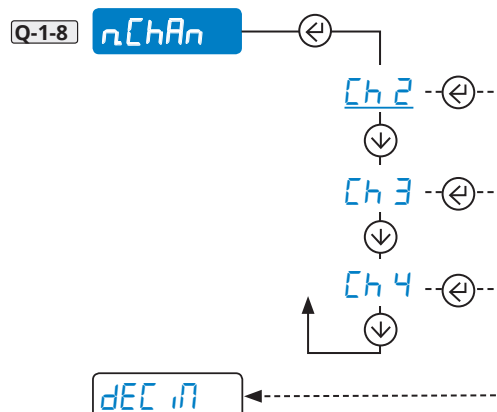



MENU

How to enter

1. Off
2. On
- 3.

Page 8

How to browse

- =
- =
- =
- =

How to save and exit



Page 8

EQUALP Equalization



EQUALP is only visible if the function **EQUAL** (Q-1-7) is activated in the menu **CALPAR** (Q-1).

The equalization wizard asks to acquire the zero point with scale unloaded and to later place a weight of about 1/8 of the maximum capacity (Max) on each individual cell, in the required order. After the procedure the message **E9.oH** will appear.

Proceed with the calibration.

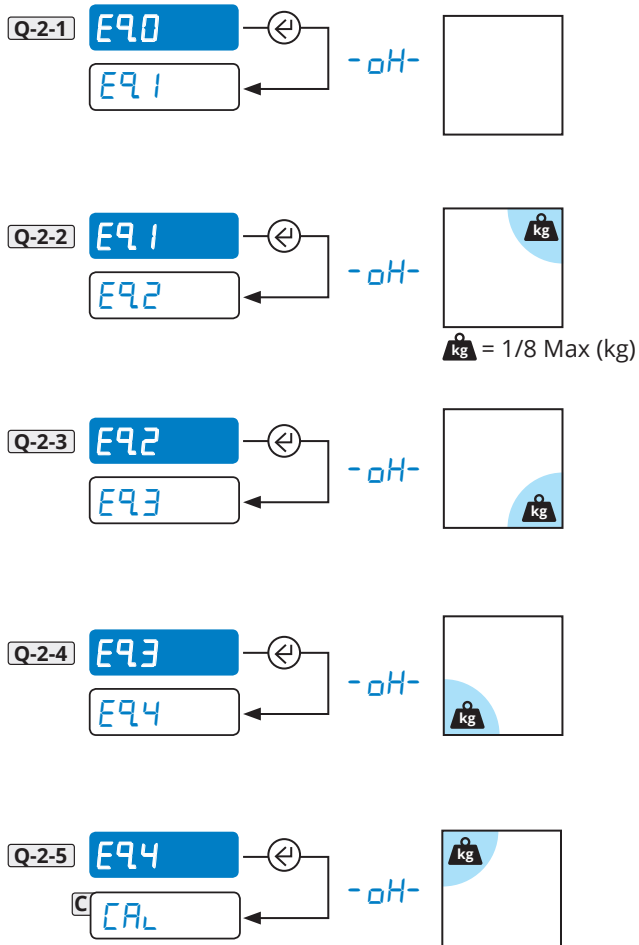
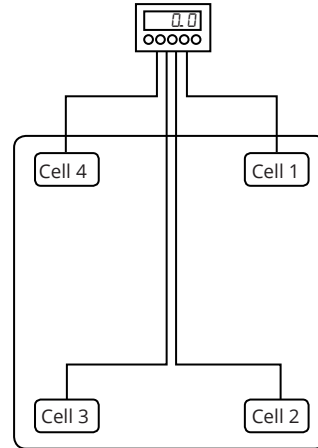

A **CAL**

B **QCAL**

C **GrAu**

D **SEr iAL**

E **LAYoUt**

F **F iLtEr**

G **SCrEEr**

H **bAtE**

I **ECabAt**

J **AUtoFF**

K **rENotE**

L **AnoUt**

M **inPUtS**

N **oUtPUt**

O **rESEt**

P **d iAG**

Q **AduAnC**

1 **CALPAR**

2 **EQUALP**

3 **CALAdu**

4 **no iSE**

5 **NEtroL**

6 **HEYb**

7 **t iLt**

8 **rEAct**

9 **LoCHHb**

10 **AL iB iR**

11 **P iNtEC**

12 **P iNUSE**

13 **dFLtE**

1 **E90**

2 **E91**

3 **E92**

4 **E93**

5 **E94**

MENU

How to enter

1. Off
2. On
- 3.

Page 8

How to browse

- =
- =
- =
- =

How to save and exit



Page 8

A CAL

B QCAL

C GrAu

D SEr iAL

E LAYoUt

F FilteR

G SCrEEn

H bAtt

I ECabAt

J AUtoFF

K rENotE

L AnOUt

M inPUtS

N oUtPUt

O rESEt

P d iAG

Q AdvAnc

1 CALPAR

2 EQUALP

3 CALAdv

4 no iSE

5 NEtroL

6 HEYb

7 t iLt

8 rERAct

9 LoCHHb

10 AL iB iR

11 P iNtEC

12 P iNUSE

13 dFLtT

1 2Ero

CALAdv Complete calibration



Before calibrating, configure the decimals (*dEE* - Q-1-1), the division (*d iU* - Q-1-2) and the capacity (*rAnGE* - Q-1-4,5,6).

Start of the calibration procedure:

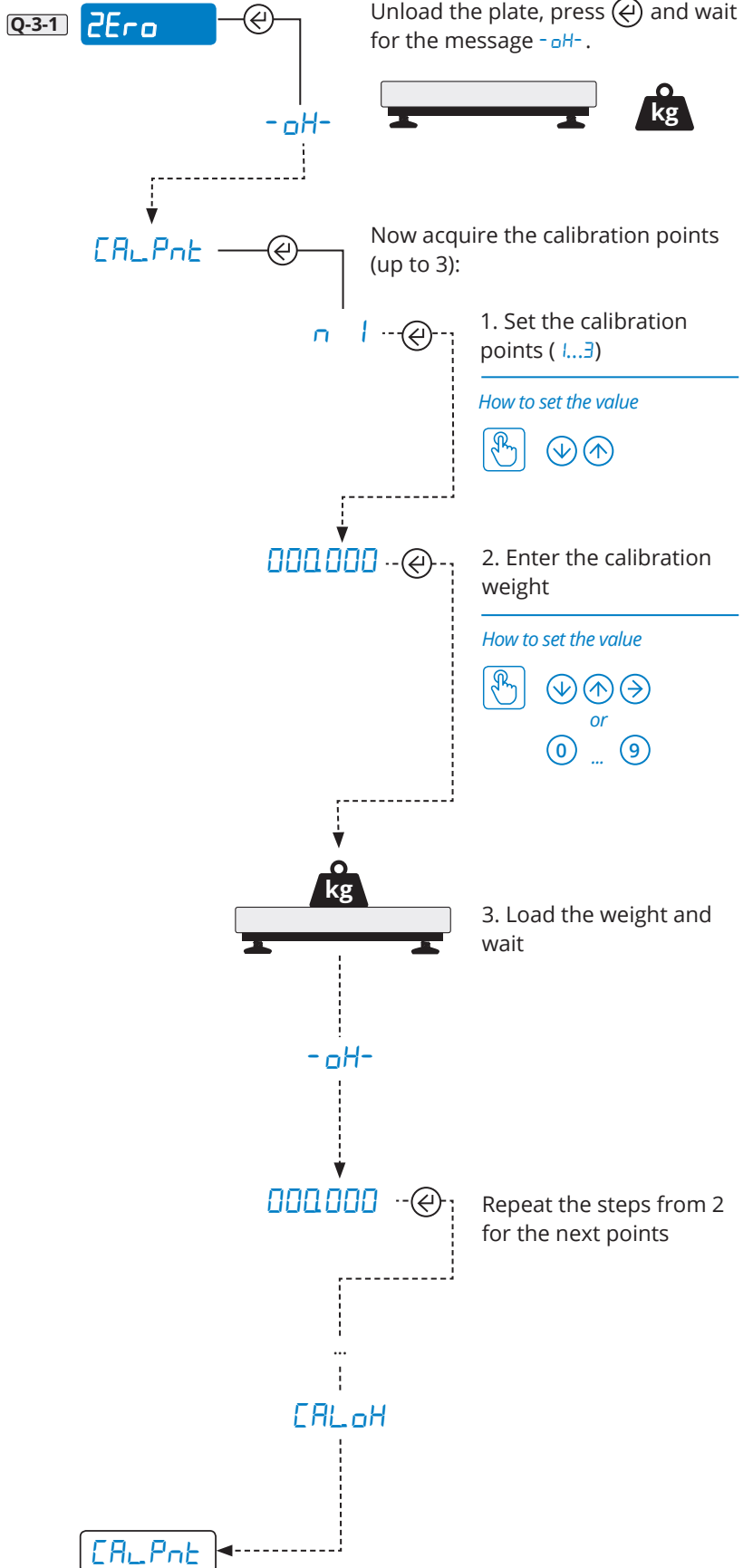



MENU

How to enter

1. Off
 2. On
 - 3.
- Page 8

How to browse

- =
- =
- =
- =

How to save and exit



Page 8

- A CAL
- B QCAL
- C GrAu
- D SEr iAL
- E LAYoUt
- F Filter
- G SCrEEr
- H bAtt
- I ECabAt
- J AUtoFF
- K rENotE
- L AnoUt
- M inPUtS
- N oUtPUt
- O rESEt
- P d iAG
- Q **AduAnC**

- 1 CALPAR
 - 2 EQUALP
 - 3 CALAdU
 - 4 **no iSE**
 - 5 **NEtrol**
 - 6 HEYb
 - 7 t iLt
 - 8 rEAct
 - 9 LoCHHb
 - 10 AL ib r
 - 11 P inTEC
 - 12 P inUSE
 - 13 dFLt
- 1 **QPErC**
 - 2 **d iuStb**
 - 3 **QtrH**
 - 4 onZEro
 - 5 CALAdU
 - 6 CALPAR
 - 7 d.SALE

Additional filter for weighing in the presence of vibrations and for weighing live animals.

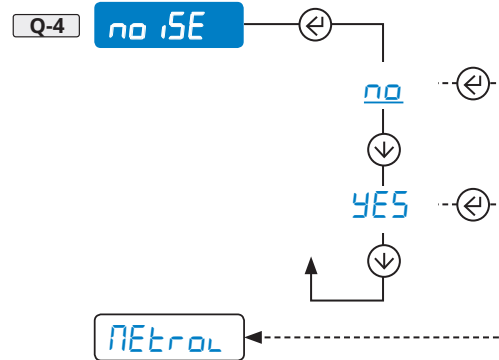

To weigh live animals, we recommend the combination with filter **StAnd** (F-1,2,3,4) or **SLo!!** (F-17,18,19,20). (See page 25)

NEtrol Metrological parameter



Reset percentage via key

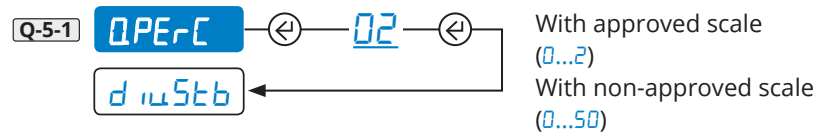

Sensitivity of the weight stability control

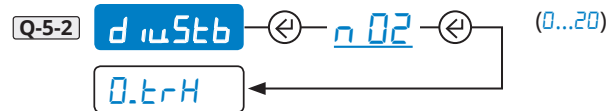

Zero hold function (tracking)

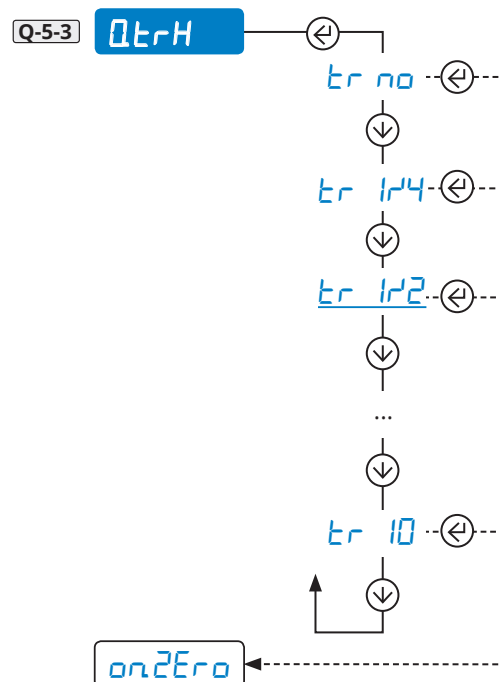



MENU

How to enter

- Off
- On
-

Page 8

How to browse

- =
- =
- =
- =

How to save and exit



Page 8

- A CAL
- B QCAL
- C CrAu
- D SEr iAL
- E LAYoUt
- F FilteR
- G SCrEEEn
- H bAtt
- I ECabAtt
- J AUtoFF
- K rENotE
- L AnoUt
- M inPUtS
- N oUtPUt
- O rESEt
- P d iAG
- Q AdvAnC

- 1 CALPAR
- 2 EQUALP
- 3 CALAdU
- 4 no iSE
- 5 NEtroL
- 6 HEyb
- 7 t iLt
- 8 rEACt
- 9 LoCHAb
- 10 AL iB iR
- 11 P iNtEC
- 12 P iNUSE
- 13 dFLt
- 1 QPERC
- 2 d iUSTb
- 3 QtrH
- 4 onZEro
- 5 CALAdJ
- 6 CALNAn
- 7 d.SALE

Reset at power and reset percentage

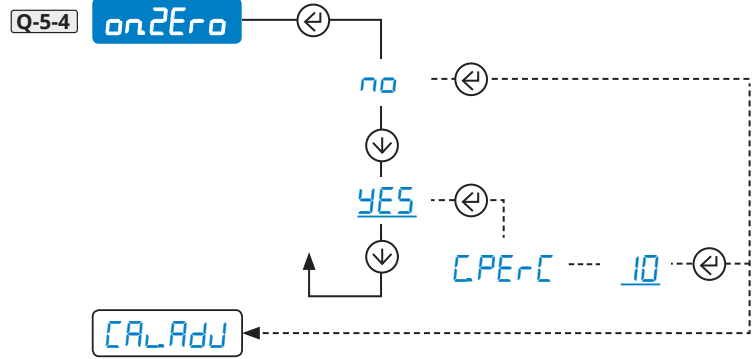

Reacquisition/change of the calibration points in memory.

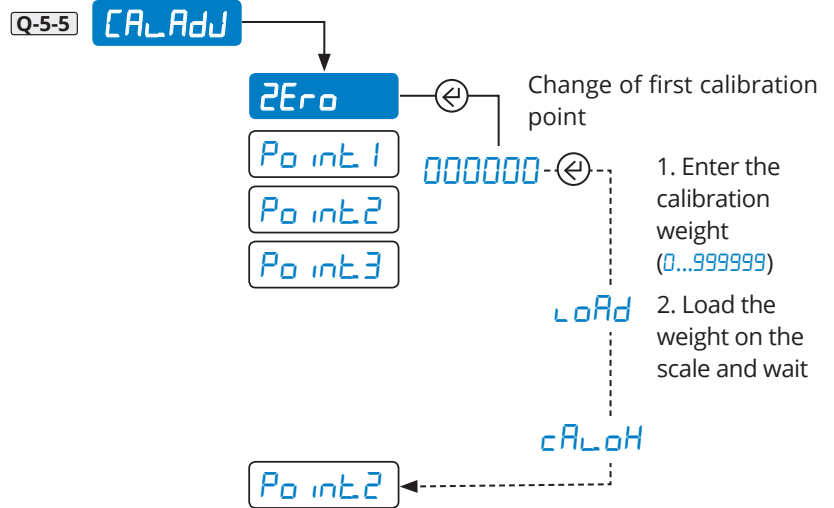

Repeat the same operation for Po iNt 1, Po iNt 2 e Po iNt 3

Q-5-6 CALNAn For use by the manufacturer.

Q-5-7 dSALE For use by the manufacturer.

Type of keyboard

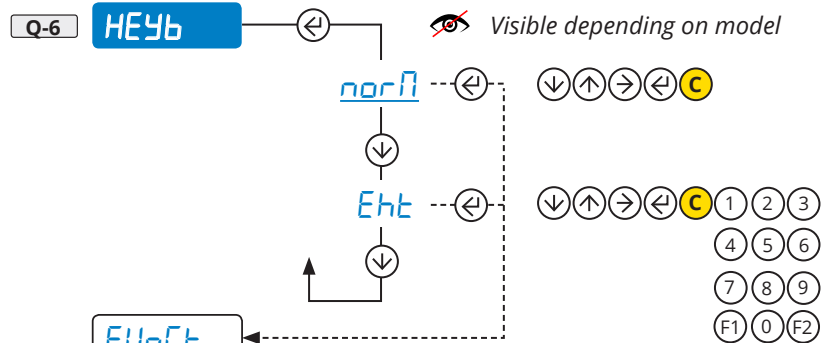

Inclinometer (for use by the manufacturer)

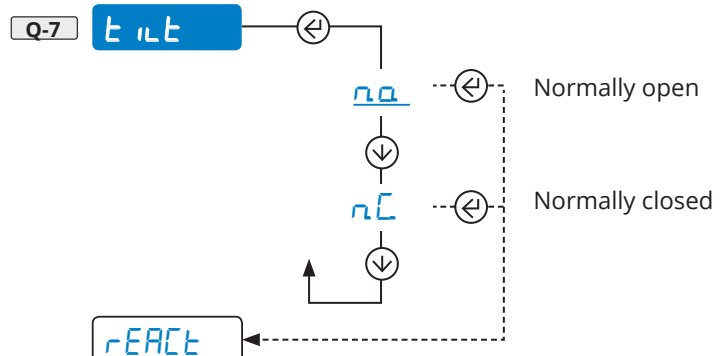



MENU

How to enter

1. Off
2. On
- 3.

Page 8

How to browse

- ↑ =
- ↓ =
- =
- ← =

How to save and exit



Page 8

A CAL

B QCAL

C GrAu

D SEr iAL

E LAYoUt

F FilteR

G SCrEEr

H bAtt

I ECobAt

J AUtoFF

K rENotE

L AnoUt

M inPUtS

N oUtPUt

O rESEt

P d iAG

Q AduAnC

1 CALPAR

2 EQUALP

3 CALAdU

4 no iSE

5 rEtrol

6 HEYb

7 t iLt

8 rEAct

9 LoCHHb

10 Al ib ir

11 P inTEC

12 P inUSE

13 dFLtE

Reactivation of the totalization or print function

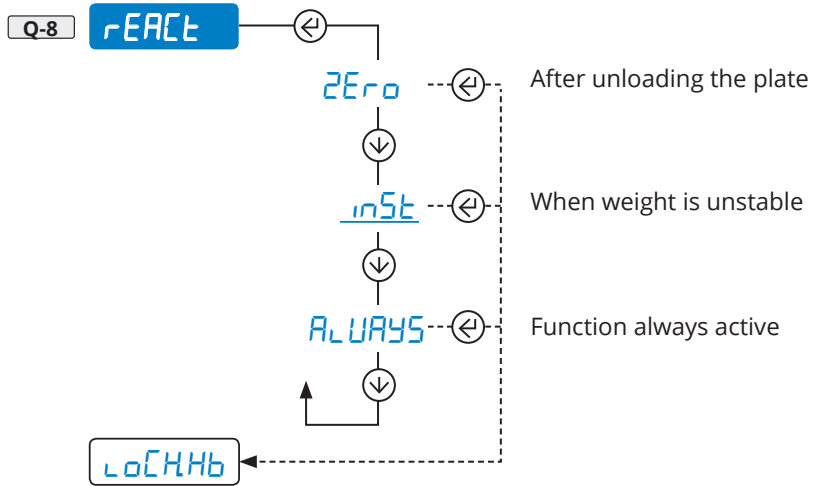

Permanent keyboard lock (excluding key)

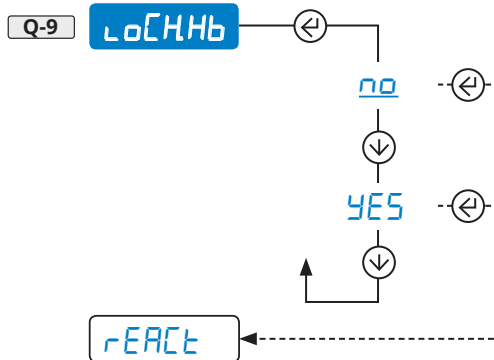

Reset of fiscal memory (alibi memory, optional)

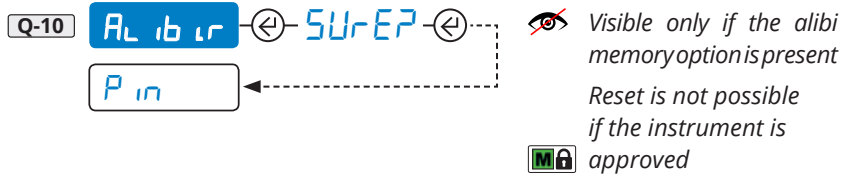

Access PIN to programming menu

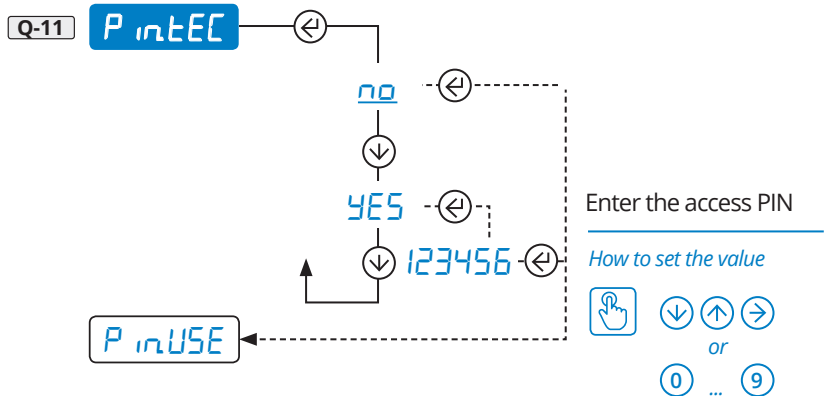

Access PIN to user menus

Q-12 P inUSE View P inTEC

Total reset of memory and of calibration, with reset of the factory settings.

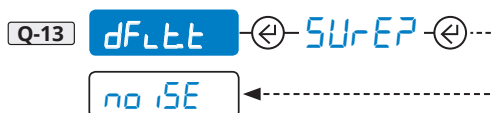

6. COMMUNICATION STRINGS

Short string

01ST,GS, 0.0,kg<CR><LF>

where

01	Code 485 of the instrument (2 characters), only if communication mode 485 is enabled
ST	Scale status (2 characters): <u>US</u> - Weight unstable <u>ST</u> - Weight stable <u>OL</u> - Weight overload (out of range) <u>UL</u> - Weight underload (out of range) <u>TL</u> - Scale not level (inclinometer active)
,	ASCII 044 character
GS	Type of weight data (2 characters)
,	ASCII 044 character
0.0	Weight (8 characters including the decimal point)
,	ASCII 044 character
kg	Unit of measurement (2 characters)
<CR><LF>	Transmission terminator, characters ASCII 013 and ASCII 010

Extended string

01ST,1, 0.0,PT 20.8, 0,kg<CR><LF>

where

01	Code 485 of the instrument (2 characters), only if communication mode 485 is enabled
ST	Scale status (2 characters): <u>US</u> - Weight unstable <u>ST</u> - Weight stable <u>OL</u> - Weight overload (out of range) <u>UL</u> - Weight underload (out of range) <u>TL</u> - Scale not level (inclinometer active)
,	ASCII 044 character
1	ASCII 049 character
,	ASCII 044 character
0.0	Net weight (10 characters including the decimal point)
,	ASCII 044 character
PT	Indication of pre-set manual tare (2 characters)
20.8	Tare weight (10 characters including the decimal point)
,	ASCII 044 character
0	Number of pieces (10 characters)
,	ASCII 044 character
kg	Unit of measurement (2 characters)
<CR><LF>	Transmission terminator, characters ASCII 013 and ASCII 010

7. COMMUNICATION CONTROLS

Premise:

in the serial controls and in the relative responses

nn	Address 485 of the instrument (2 characters) (only if communication mode 485 is activated)
<CR>	Terminator character ASCII 13 (0D) (1 character)
<LF>	Terminator character ASCII 10 (0A) (1 character)

Reading of simple weight

Control	nnREAD<CR><LF>
Response	Short string (see page 41)

Reading of complete weight

Control	nnREXT<CR><LF>
Response	Extended string (see page 41)

Execution of a semi-automatic tare

Control	nnTARE<CR><LF>
Response	OK<CR><LF> indicates that the control was received correctly

Setting of the tare value (PT)

Control	nnTMANtttttttt<CR><LF> Where t...t is the tare, with decimal points, max 8 characters.
Response	OK<CR><LF> indicates that the control was received correctly
Examples	TMAN1,56<CR><LF> set a tare of 1.56 TMAN100<CR><LF> set a tare of 100

Deleting the tare in memory

Control	nnCLEAR<CR><LF>
Response	OK<CR><LF> indicates that the control was received correctly

Scale reset (function of the ZERO key)

Control	nnZERO<CR><LF>
Response	OK<CR><LF> indicates that the control was received correctly

SPECIFIC CONTROLS FOR ALIBI MEMORY (OPTIONAL)

Storage requests

Control	nnPID<CR><LF> request to store the weight
Response	recording successful nnPIDss,c,wwwwwwwwwwuu,ppttttttttuu,xxxxx-yyyyyy<CR><LF>
	no recording nnPIDss,c,wwwwwwwwwwuu,ppttttttttuu,NO<CR><LF>
where:	
ss	status of weight (2 characters)
TL	Error of condition of E_{IL} (NO RECORDING)
OL	Condition of o_{uERLd} (NO RECORDING)
UL	Condition of u_{ndERLd} (NO RECORDING)
ST	Weight stable
US	Weight unstable (NO RECORDING)
c	Scale number (1 character)
w...w	Gross weight (10 characters)
uu	Unit of measurement (2 characters)
pp	Type of tare: double space " " if semi-automatic, "PT" if pre-set (2 characters)
t...t	Tare value (10 characters)
xxxxx	Number of rewriting (5 characters)
yyyyyy	Progressive weighted (6 characters)
Examples	PIDST,1, 1500,0kg,PT 2,8kg,00000-000158<CR><LF> PIDUS,1, 1500,0kg,PT 2,8kg,NO<CR><LF>

Reading of a weighing in memory

Control	nnALRDxxxxx-yyyyyy<CR><LF> Where xxxxx is the rewriting number, yyyyyy is the progressive weighted.
Response	s, w w w w w w w w w w u u , p p t t t t t t t t t t u u<CR><LF>
where:	
s	Number of scales (always 1)
w...w	Gross weight (10 characters)
uu	Unit of measurement ("g", "kg", "t", "lb")
pp	Type of tare: double space " " if semi-automatic, "PT" if pre-set (2 characters)
t...t	Tare value (10 characters)
Examples	ALRD00000-000158<CR><LF> 1, 1500,0kg, 2,8kg<CR><LF>

8. WIRING SCHEMES

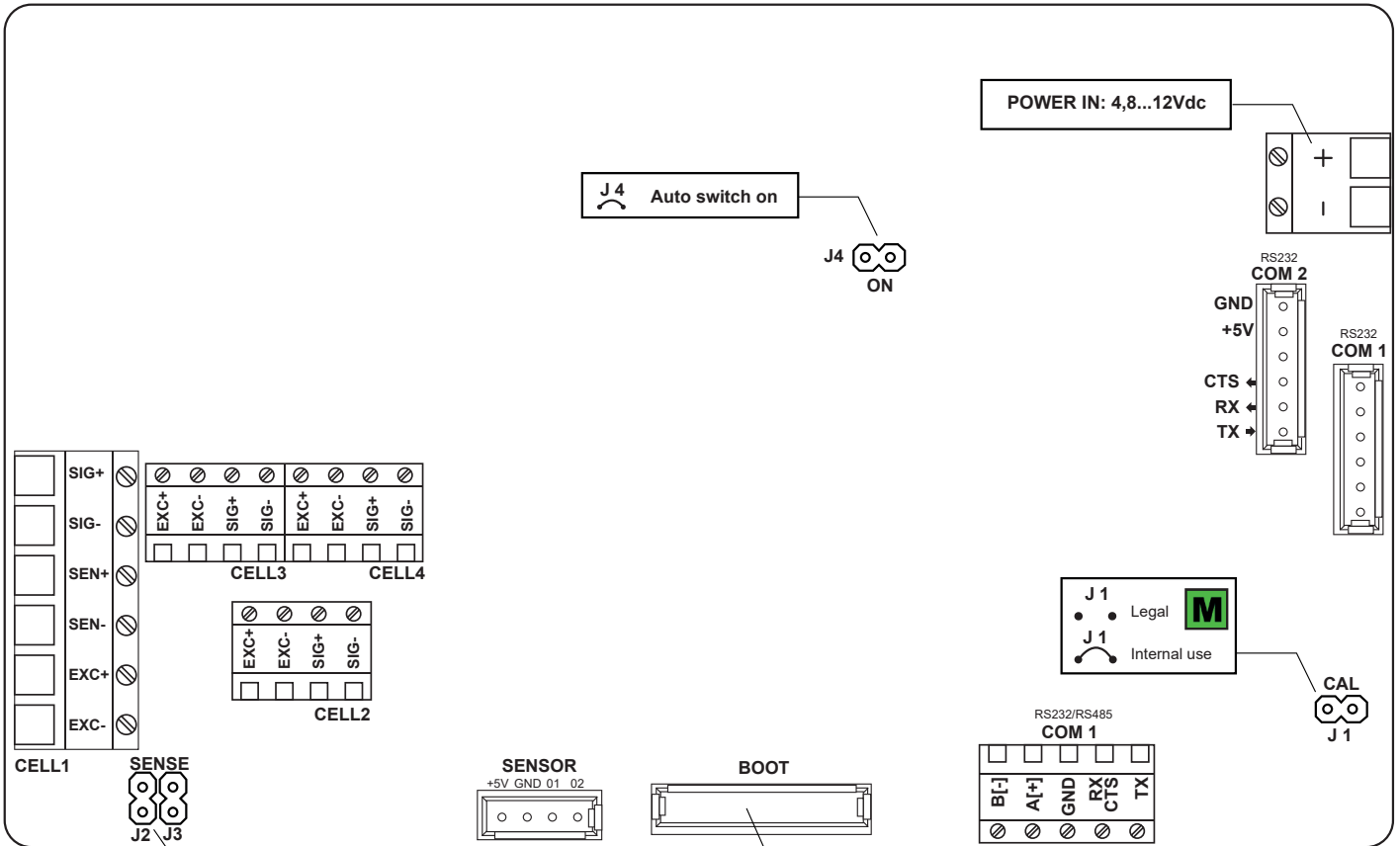

RLT

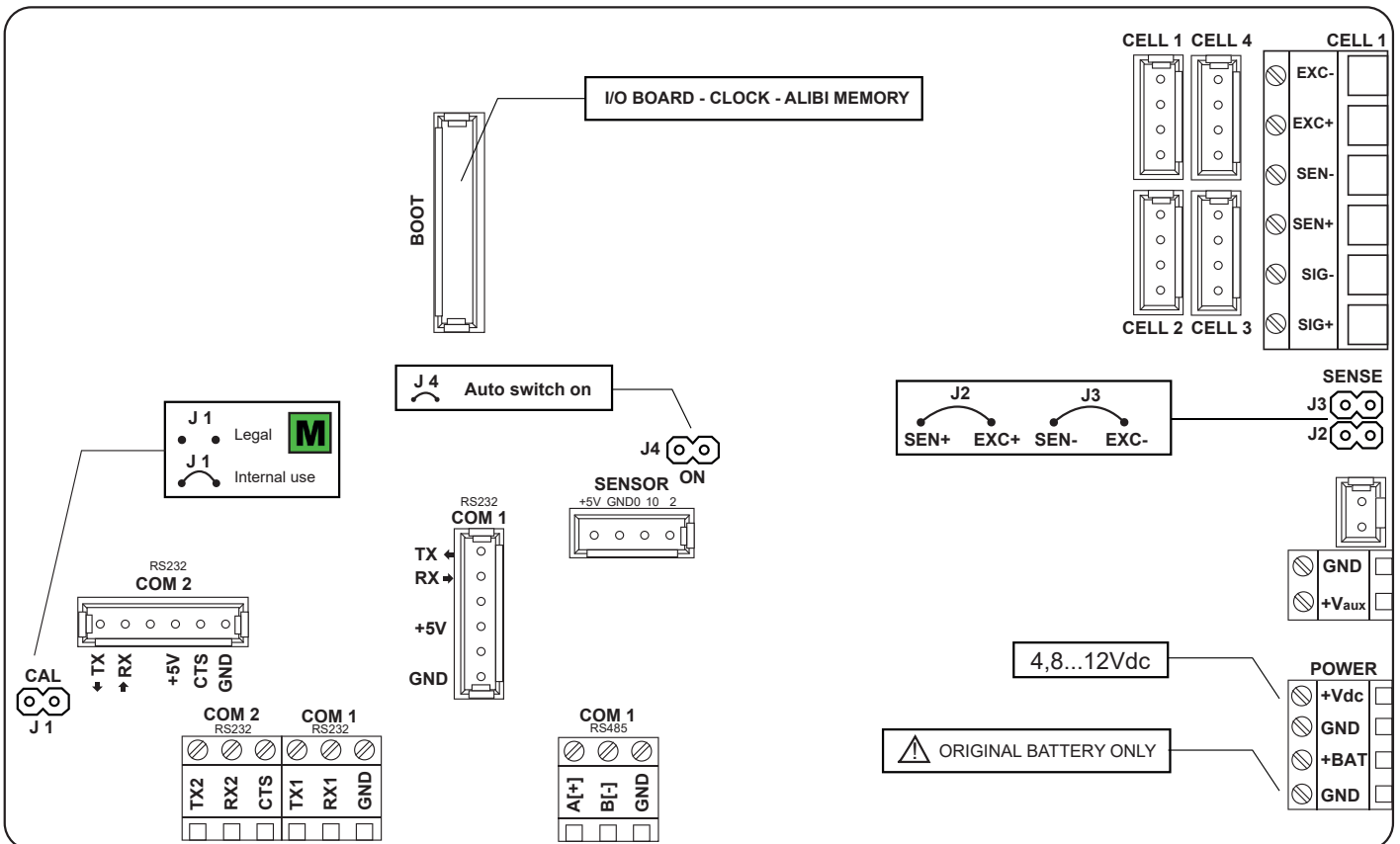

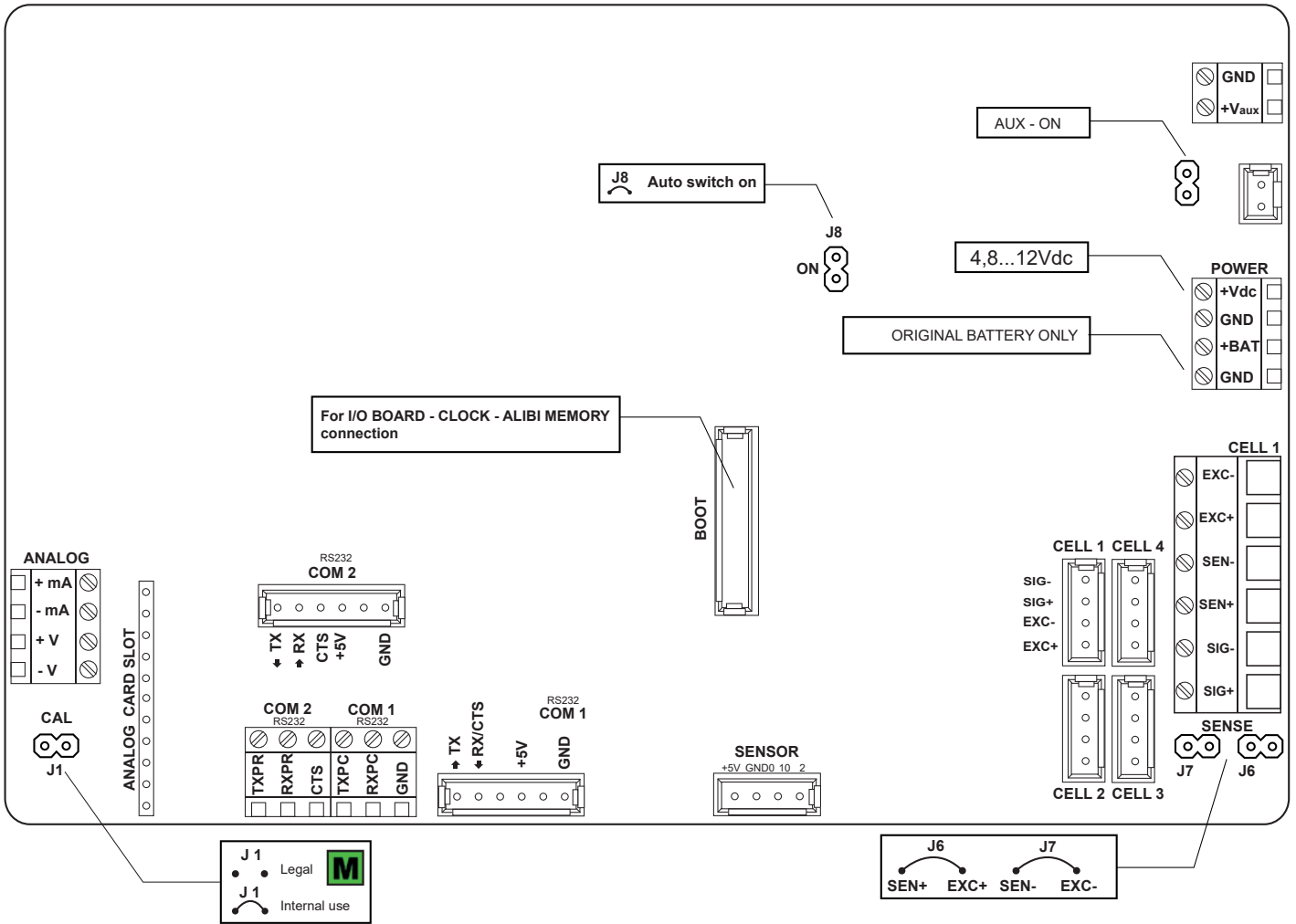

9. PROGRAMMING ERRORS

MESSAGE	DESCRIPTION	SOLUTION
<i>ALErr</i>	Board "alibi memory" (optional) not detected	Check the presence of the board inside the indicator. If present, check it is not damaged and is installed correctly
<i>Er. I b H</i>	Board "inputs/outputs" (optional) not detected	Check the presence of the board inside the indicator. If absent, deactivate any inputs or outputs (parameter " <i>INPUTS</i> " or " <i>OUTPUT</i> ", see page 31-32). If present, check it is not damaged and ensure it is installed correctly
<i>Er.r.bH</i>		
<i>E9Err</i>	Impossible to perform equalization	Ensure the cells are connected properly. Check the signal of each cell in the diagnostic menu (menu <i>d.AG</i> , parameter <i>AdCUu</i> , see page 33)
<i>PrEC</i>	Calibration error	First calibrate the zero point, then proceed with the next points
<i>Err.Pnt</i>	Calibration error	Check the connection of the load cell. Check that the cell signal is stable, valid and greater than that of the previously acquired point
<i>Er 11</i>	Calibration error	Increase the calibration weight
<i>Er 12</i>	Calibration error	Check that the signal coming from the cell increases upon the increasing of the weight loaded on the scale. When acquiring the calibration points, use the increasing calibration weights
<i>Er 37</i>	Calibration error	Repeat the calibration, checking that the capacity and division have been correctly set
<i>Er 39</i>	Instrument not configured	Reset the factory configurations (menu <i>AdwAnC</i> , parameter <i>dFLtEt</i> , see page 40)
<i>Er 85</i>	Instrument configured but not calibrated	Perform calibration
<i>CEr. 36</i>	Calibration error	Check that the signal coming from the load cell is not negative
<i>Err.NoI</i>	Weight unstable	Check in menu <i>d.AG</i> , parameter <i>AdCUu</i> (see page 33) that the signal is stable and re-try. If the connection of the cells is with 4 wires, check that the sense jumpers are inserted

10. FAQ - FREQUENTLY ASKED QUESTIONS

Calibration

Can I change the maximum capacity without recalibrating?

Yes, you must change the parameters [rANGE L23](#) (Q-1-4,5,6). (See page 35)

Can I change the division without recalibrating?

Yes, you must change the parameter [d.u](#) (Q-1-2). (See page 35)

Can I change the position of the decimal point without recalibrating?

Yes, you must change the parameter [DEC pt](#) (Q-1-1) and the value of the calibration points via the pitch [CAL Pt](#) (Q-5-6). (See page 35 and 39)

Can I calibrate the instrument in “multi-division” mode?

Yes, through advanced configuration from PC.

Communication

Scale doesn't answer

- Check the condition of the cable and that there are no failures (using a multimeter).
- Check the PC communication port or that the device used is not compromised. If necessary, try with another device/PC
- Make sure cable is connected on the correct serial port.
- Check the configuration of the pitches [bAUD](#) and [b.t.](#). (See page 13)
- Temporarily activate the continuous communication and retry receiving the string. If the string has been received correctly, carefully check the syntax of the control sent, the communication time-outs and the presence of the terminator.

Generic

The scale does not switch on

- Check the input voltage level to the mother board is correct.
- Try the forced power by inserting the “ON BOOT” jumper present on the mother board. If the indicator lights up, check the correct operation of the keyboard, using the diagnostic menu [d.i.G.](#). (See page 33)
- Check possible failure of the internal rechargeable battery (if present).

11. SUMMARY OF THE PARAMETERS

CA_L	Calibration.....	10
d₁₀	Division	10
QCA_L	Reset of Pre-Tare (zero calibration).....	11
GrAV	Area of gravity of the place of use.....	11
SEr_{IAL}	Configuration of the serial ports	12
CoN_{PC}	Communication with PC, PLC or repeater	12
ModE	Selection of the communication mode	12
CoNSE_L	Selecting the COM port for connection with PC/PLC.....	13
baUd	Communication speed (baud rate).....	13
bit	Configuration of the serial protocol	13
CoN_{Prn}	Communication with printer or repeater or PC.....	14
ModE	Selection of the communication mode	14
baUd	Communication speed (baud rate).....	14
bit	Configuration of the serial protocol	15
CtS	Printer control signal.....	15
POWE_{r.P}	Printer power supply / radio-frequency module	15
AdvAn_C	Advanced configurations.....	16
Proto_C	Communication protocol.....	16
rAd_{io}	Connection port of radio frequency module (for use by the manufacturer).....	16
tTLt_{IL}	TTL port/Inclinometer activation (for use by the manufacturer).....	16
tE_rn	Closing character of each print line.....	16
LA_Yo_UT	Print customization.....	17
LA_{NG}	Setting of the print language (<i>ItAL, EnGL, dEUT, FrAn, ESPA, Ch inES</i>)	18
ChAr	Setting the character	18
hEAdEr	Print header.....	19
dAtA	Selection of the weight data.....	21
WE_ight	Progressive weighed	21
t_iChEt	Receipt/label progressive	21
CLo_{CH}	Date and time.....	22
baRc₃₉	Bar code 39.....	22
baRc_{UP}	Barcode top margin (mm)	22
baRc_L	Barcode left margin (mm).....	22
baRc_h	Barcode height (mm).....	22
baRc_{dt}	Selection of the weight data.....	23
CoP_{iES}	Multi-copy prints.....	23
Endt_{iC}	Paper outlet for end of label/receipt.....	23
bl_{inE}	White pre-heating line of the print head (for thermal printer only).....	23
LABE_L	Label configuration.....	24
LSAV_E	Saving of labels in the printer memory.....	24
tEST	Saving of labels in the printer memory and test print of all formats.....	24
F_{ILtEr}	Weighing filters.....	25
SCrEEn	Adjusting the display.....	26
baK_Lit	Backlighting	26
br_ight	Brightness.....	26
Lo_{CH}	Display lock (for use by the manufacturer)	26
CoLo_{Ur}	Backlighting color (in versions with color display).....	26

bAtt	Power supply via battery.....	27
ECabAt	Energy saving for battery operation	27
AutoFF	Auto off.....	28
rEMotE	Remote control.....	28
AnoUt	Analog output.....	29
inPUtS	Digital inputs.....	31
oUtPUt	Digital outputs.....	32
rESEt	Factory configuration reset.....	33
d iAG	Diagnostics.....	33
AdCUU	Converter.....	33
d iSPLA	Display.....	33
HEyb	Keyboard.....	33
AdvAnC	Advanced.....	34
CA_LPAR	Calibration parameters.....	34
dEC iN	Configuration of the decimal point.....	34
d iu	Reading division	34
UN	Unit of measure	34
rAnGE 1	Scale capacity (maximum capacity/first weighing range).....	35
rAnGE 2	For multirange scales (second weighing range).....	35
rAnGE 3	For multirange scales (third weighing range).....	35
EQUAL	Equalization function.....	35
nChAn	Equalized analog channels	35
EQUALP	Equalization.....	36
CA_LAdJ	Complete calibration.....	37
no iSE	Additional filter for weighing in the presence of vibrations and for weighing live animals.....	38
MEtroL	Metrological parameters	38
QPErC	Reset percentage via key (⏴).....	38
d iuStb	Sensitivity of the weight stability control	38
QtrH	Zero hold function (tracking).....	38
onZEro	Reset at power and reset percentage	39
CA_LAdJ	Re-acquisition / change of the calibration points in memory	39
CA_LPAR	For use by the manufacturer.....	39
dSALe	For use by the manufacturer.....	39
HEyb	Type of keyboard	39
t iLt	Inclinometer (for use by the manufacturer).....	39
rEAct	Reactivation of the totalization or print function	40
LoCHKb	Permanent keyboard lock (excluding key (C)).....	40
Al iB iC	Reset of fiscal memory (alibi memory, optional).....	40
P inTEC	Access PIN to programming menu.....	40
P inUSE	Access PIN to user menus	40
dFlEt	Total reset of the memory and of calibration.....	40



© Rice Lake Weighing Systems Europe B.V. Specifications subject to change without notice.
Rice Lake Weighing Systems is an ISO 9001 registered company.

NL-6666 MH Heteran • Netherlands
TEL: +31 (0)26 472 1319 • FAX: +31 (0)88 234 9100