

# RL-HPJ-E

---

*Pallet truck with integrated scale*

## Operation Manual

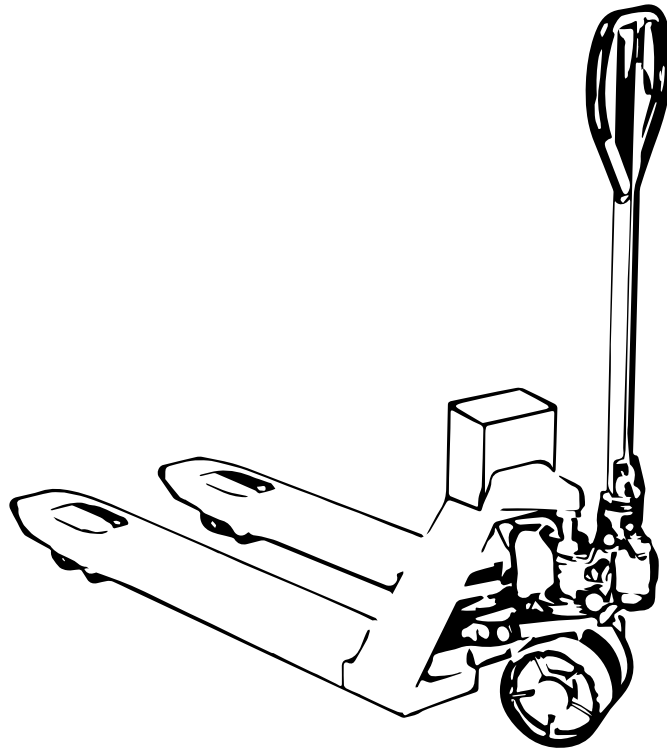

An ISO 9001 registered company  
© Rice Lake Weighing Systems. All rights reserved.

Rice Lake Weighing Systems® is a registered trademark of  
Rice Lake Weighing Systems.  
All other brand or product names within this publication are trademarks or  
registered trademarks of their respective companies.

All information contained within this publication is, to the best of our knowledge, complete and accurate at the time of publication. Rice Lake Weighing Systems reserves the right to make changes to the technology, features, specifications and design of the equipment without notice.

The most current version of this publication, software, firmware and all other product updates can be found on our website:

[www.ricelake.eu](http://www.ricelake.eu)

<b>Introduction</b>	<b>5</b>
Safety Information - Warnings	5
<b>Technical Features</b>	<b>6</b>
<b>Power Supply</b>	<b>7</b>
Power supply via battery	7
Power supply via rechargeable battery	7
Battery charge level	7
<b>Tiller/Column Assembly</b>	<b>8</b>
<b>Truck Controls</b>	<b>9</b>
Transport	9
Lifting	9
Lowering	9
<b>Printer</b>	<b>10</b>
Integrated thermal printer	10
Customizable printouts	10
<b>Accessories</b>	<b>11</b>
Swivel column (standard with some models)	11
USB (depending on model)	11
Antenna (depending on model)	11
Brake	11
<b>Instructions for Use</b>	<b>12</b>
<b>Correct Weighing Procedure</b>	<b>14</b>
<b>Maintenance</b>	<b>15</b>
Maintenance warnings	15
Scheduled maintenance	15
Daily maintenance	15
Regulation of forks lowering	16
Oil level	17

<b>Basic Scale Functions</b>	<b>18</b>
The Display	18
On	19
Off	19
Zero	19
Regulation of the display brightness	19
Automatic tare	20
Tare deletion	20
Presetable tare (PT)	21
Print (and reprint of the last ticket)	22
Metrics	22
<b>Additional Functions for Models with Number Keypad</b>	<b>23</b>
30-tare memory	23
Automatic tare deletion	24
Number IDs	25
Date and time	26
<b>Advanced Scale Functions</b>	<b>27</b>
How to access the function menu	27
Horizontal totalization	28
Mixing several components	30
Piece counting	32
Weight check	35
Exchange between net weight and gross weight	38
Percentage weighing	39
Unit of measure conversion	42
<b>Identification of the Metrological Software</b>	<b>43</b>
<b>FAQ – Frequently Asked Questions</b>	<b>44</b>
Print	44
Totalization	44
Tare	44
Weighing	45
Piece counting	45
<b>Error Messages</b>	<b>46</b>
<b>Declaration of Conformity</b>	<b>47</b>

The manual weighing pallet truck that you have purchased is ideal for handling and weighing pallets or standardised containers directly where they are located, saving you time and money.

It is equipped with high performance weighing electronic, precise and durable, and features a multifunctional program that can help you perform your daily tasks. Before using the instrument, please read this instructions manual carefully in order to be able to use it in complete safety and to learn about all of the functions it offers.

## Safety information - Warnings

The safety precautions illustrated in this manual, marked with  must be observed during all installation, operation, maintenance or repair stages of the weighing system.

Any use other than the one reported in this manual, as well as the failure to follow the safety precautions, shall relieve the manufacturer of any responsibility and void the product warranty.



- Read this manual carefully before carrying out any handling operations or lifting any loads.
- This pallet truck is designed to weigh exclusively on standardised pallets.
- With approved scale, you can perform weighing on EUR-EPAL pallet 800x1200mm (ref. Standards UIC 435-2 and UIC 435-4).
- NEVER load the scale beyond the maximum capacity stated on the plate of the weight readout instrument.
- It is forbidden to use the scale in environments where there is the danger of fire or explosion.
- Do not load the forks when they are raised, not even partially.
- Before using the pallet truck ensure it is in perfect working order.
- To achieve a correct weighing result the forks need to be raised at least 5-10 cm in order to avoid the frame from rubbing against anything.
- Do not expose the pallet truck to atmospheric agents (sun, rain, etc.).
- Use the pallet truck in non-condensing environments with moderate temperature and humidity levels
- Use the pallet truck where there are no vibrations.
- Carefully read and apply the aforementioned description of the weight indicator.
- To clean the pallet truck, avoid the use of solvents or aggressive substances.
- It is forbidden to make any modifications to the pallet if not authorised by the manufacturer.
- It is forbidden to use the pallet truck when it no longer fulfils the safety criteria.
- It is forbidden to use flammable products to clean the pallet.
- Except with specific models, it is forbidden to wash the pallet truck with direct jets of water.
- Do not pour liquids on the indicator.
- Anything not specifically described in this manual is considered improper use of the equipment.



- The crossed out wheeie bin symbol on the product shows that it must be brought to appropriate separate waste collection centres at the end of its life cycle or returned to the dealer when purchasing a new equivalent product.
- Proper separate collection to then send the product to recycling contributes to preventing possible negative effects on the environment and to health and promotes recycling. Users who dispose of the product illegally shall face administrative sanctions as provided for by law.

## Technical features

Based on the model:

- Painted steel or stainless steel loading forks.
- Standard length 1150 mm or 1280 mm, special sizes on request.
- Width 550 mm or 680 mm, special widths on request.
- Maximum lifting height of the forks: 180 mm or 200 mm from the ground.
- Height of completely lowered forks: 80 mm or 85 mm from the ground.
- Polyurethane or non-staining vulkollan or nylon or antistatic rubber steering wheels.
- Double load wheels for greater stability.
- Painted steel load bearing frame.
- 4 aluminium or stainless steel loading cells with IP67 or IP68 protection rating.
- Tiller with multifunction lever.
- Multifunction fixed or adjustable weight indicator.
- Removable rechargeable battery and set-up for 24/7 continuous use kit or battery operation.
- Integrated printer.

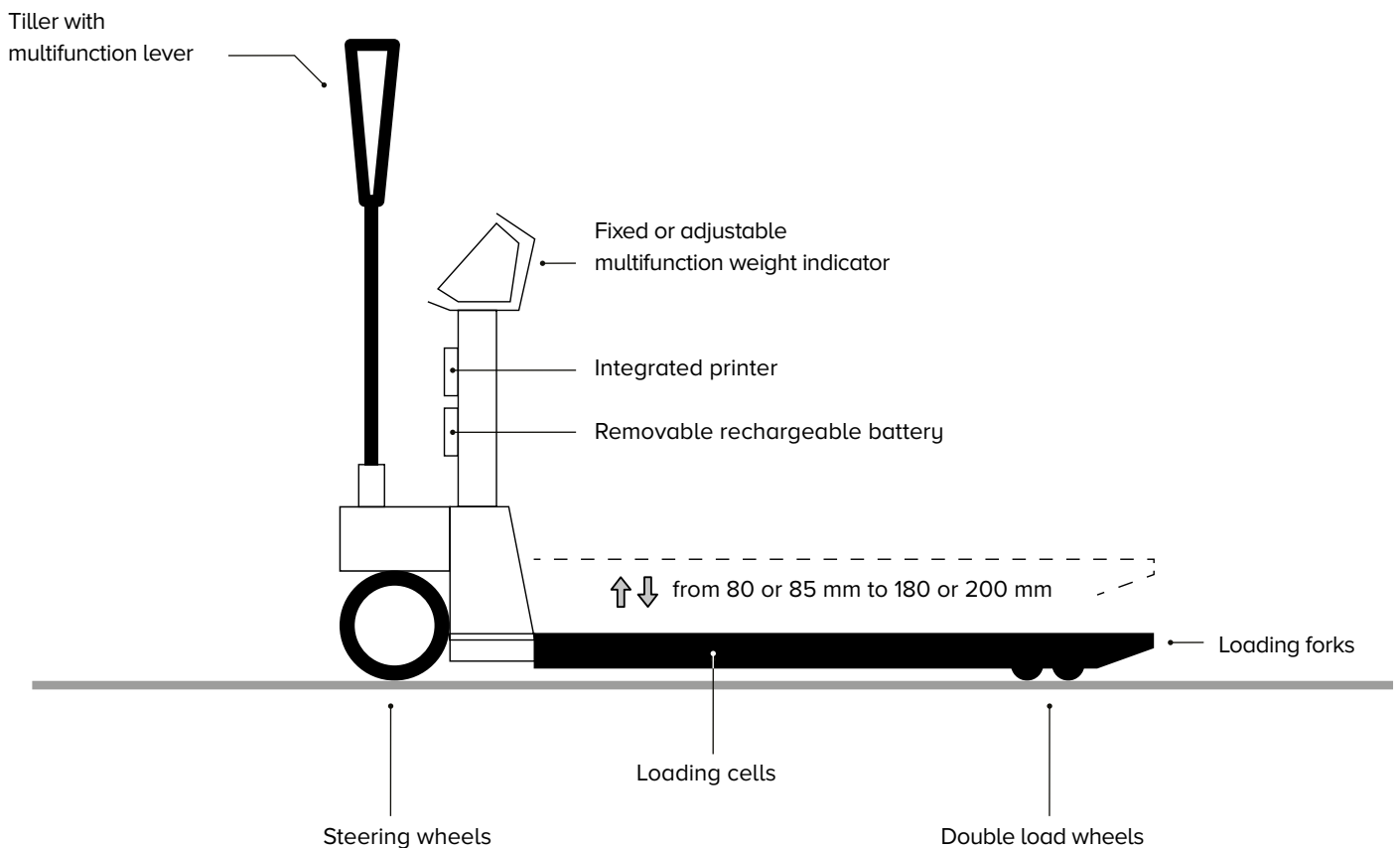

## Power supply via battery

If your pallet truck features AA BATTERY power supply, use **4 AA batteries**, either “disposable” or rechargeable.

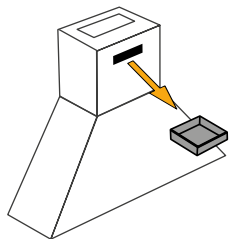

### CHANGING THE BATTERIES:

Pull out the front tray and put the batteries in.



ATTENTION: set the batteries up according to the polarity marked inside the tray.

## Power supply via rechargeable battery

Depending on what model you purchased, the weighing pallet truck can be equipped with **A** internal rechargeable or **B** removable battery.

**BEFORE TURNING THE INSTRUMENT ON FOR THE FIRST TIME, FULLY CHARGE THE BATTERY (APPROX. 12 HOURS)**

### **A** INTERNAL RECHARGEABLE BATTERY

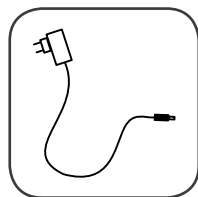

USE ONLY ORIGINAL CHARGER SUPPLIED

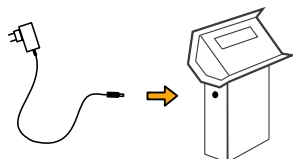

### **B** REMOVABLE BATTERY

1.



2.

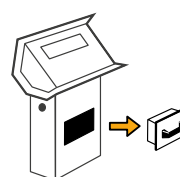

3.

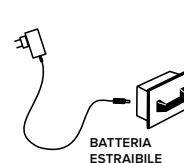

## Battery charge level

The dedicated symbol on the instrument display tells you the battery level:



i

- Only use original batteries and battery chargers.
- Under normal conditions of use, we recommend never leaving the battery partially or fully discharged and fully charging it at least once a week.
- In case of prolonged periods of disuse, we recommend removing the battery (in pertaining models) and storing it in a dry place, away from changes in temperature
- Recharge it completely once every 3 months.

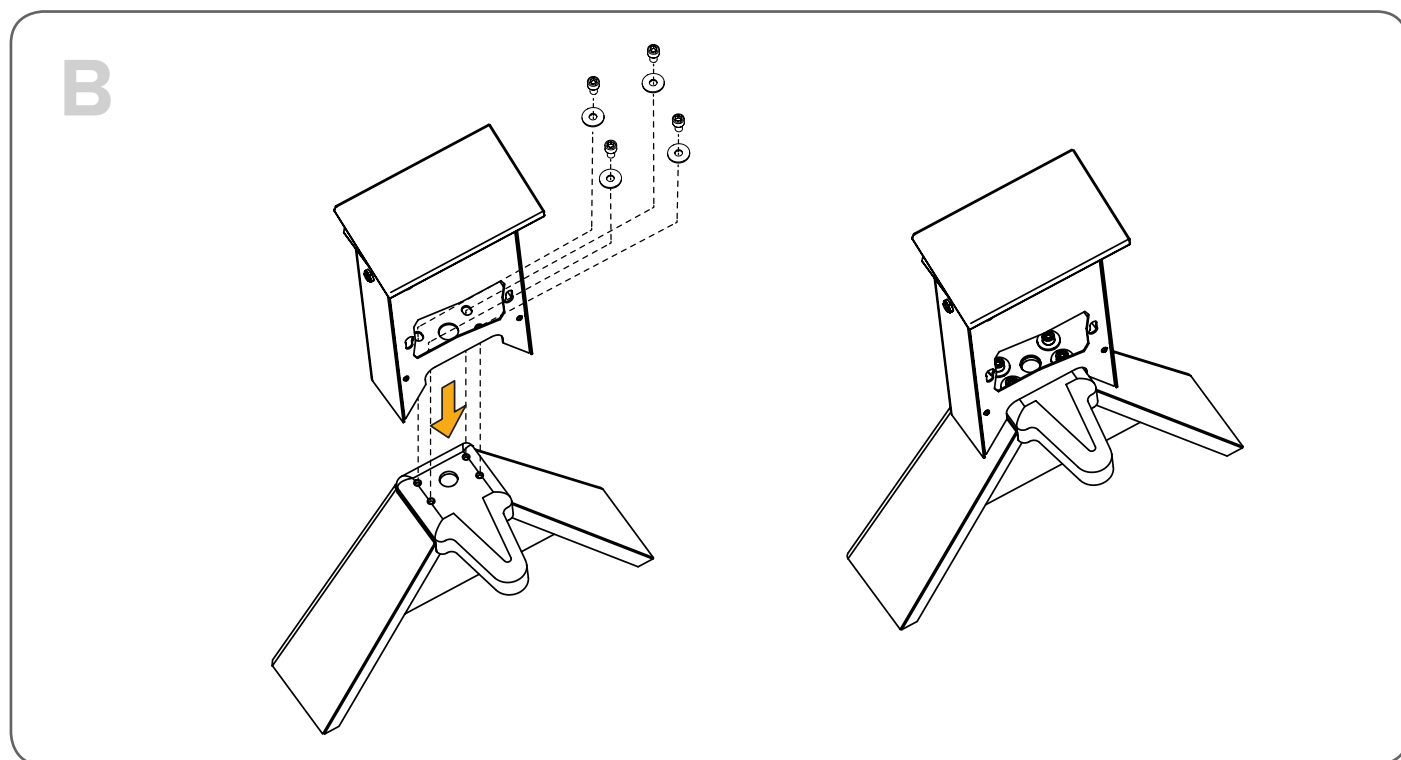
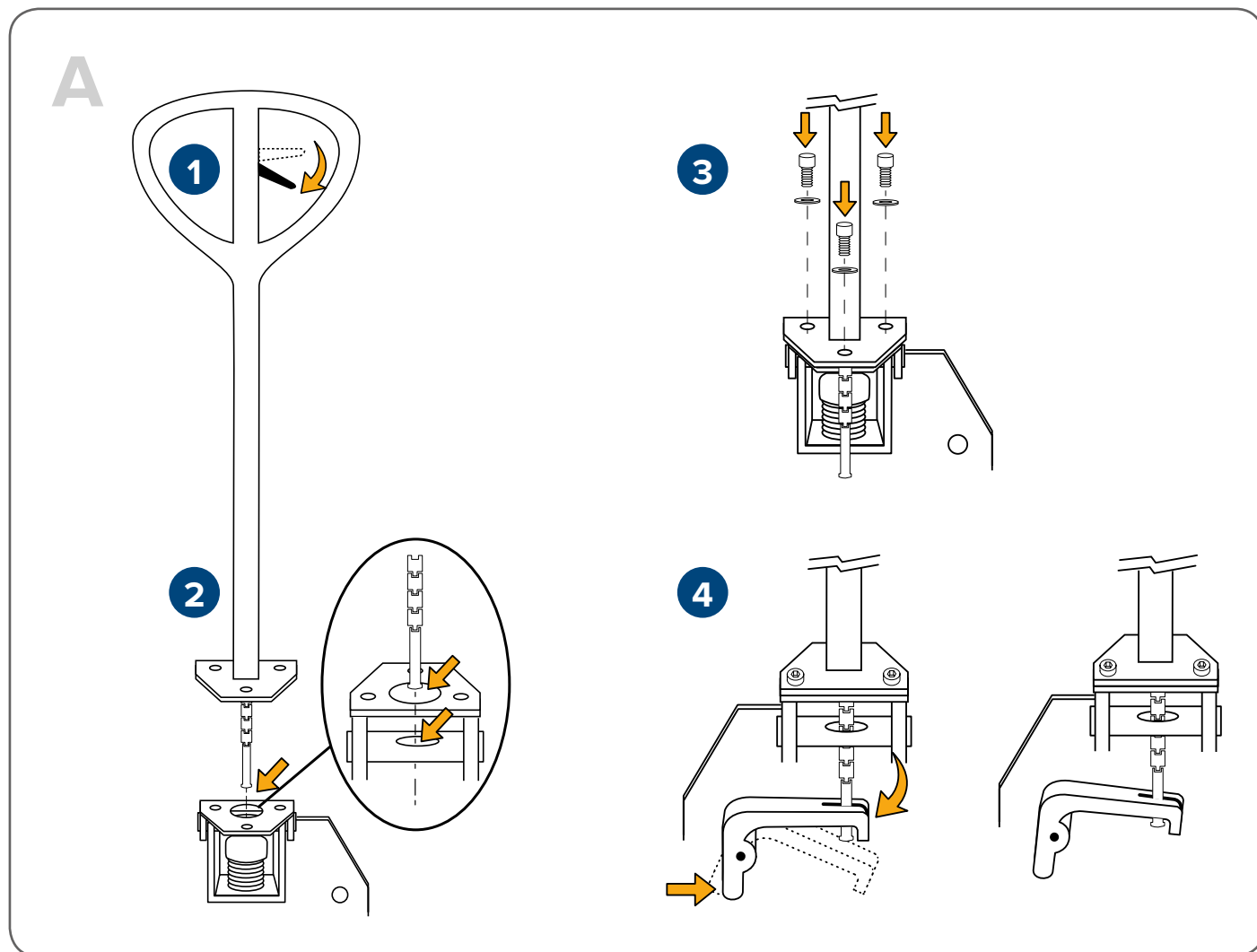

The raised load is moved forwards or backwards by the tiller, which controls the steering wheels.

## Transport

### POS. 1 > central

The tiller is completely free for transport manoeuvres.

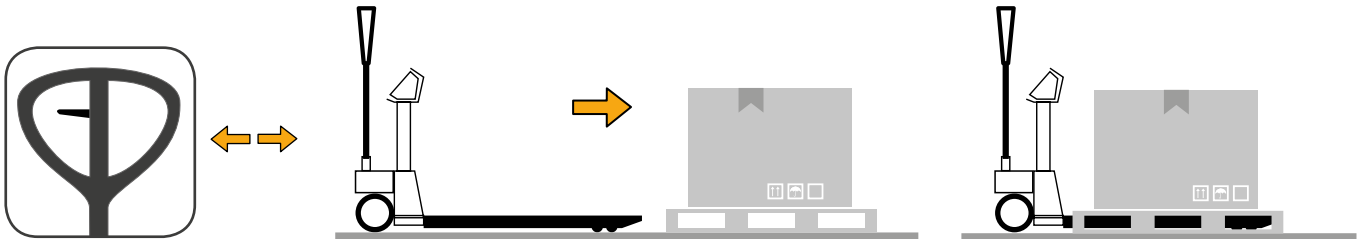

## Lifting

### POS. 2 > low

Pull the tiller downwards to start up the lifting pump. A return spring places the tiller back in its upright position.

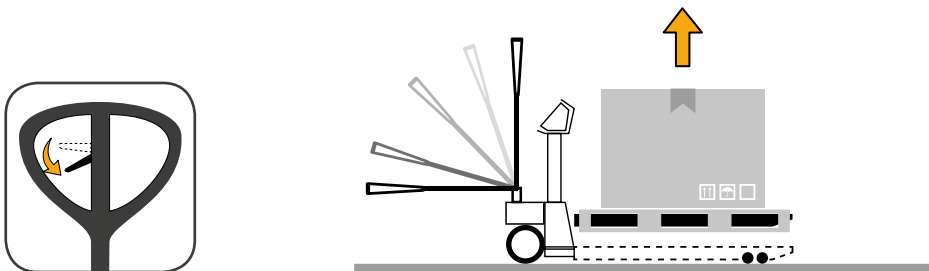

## Lowering

### POS. 3 > - high

Pull the lever upwards to lower the load. The descent speed is controlled by a special valve that starts up when the lever is firmly pulled to the end of its stroke.

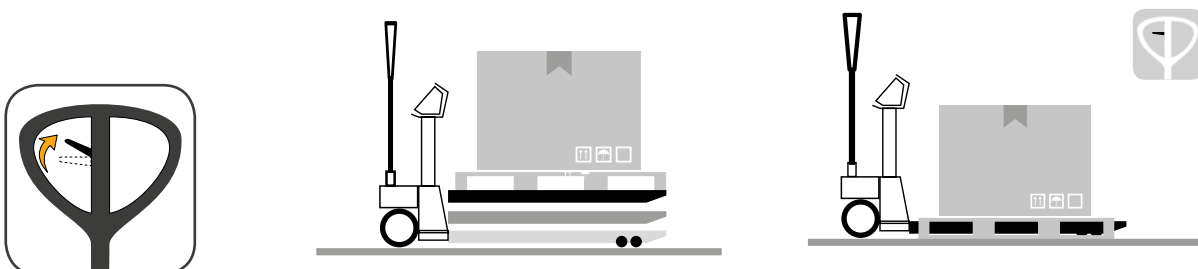

The pallet truck is equipped with a dual-function tiller: traction or manoeuvre and hydraulic lift.

**NOTE:** raise or lower the pallet truck **ONLY** when stationary.

## Integrated thermal printer

The printer is usually in STAND-BY and is only powered by the weight indicator when it is time to print in order to ensure the battery holds it charge longer.

When printing is finished, the printer automatically goes back to STAND-BY.

### How to replace the roll

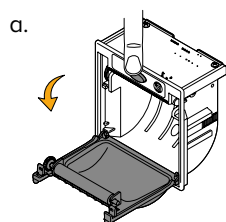

a. Open the door by pressing the middle button.

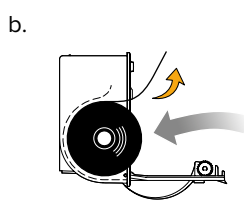

b. Put the roll in with the thermal side facing outward.

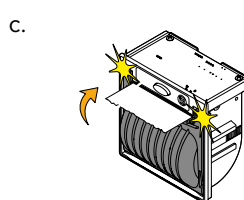

c. Close the door by pressing both sides.

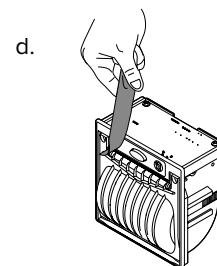

d. Remove the excess paper.

## Customisable printouts

If the instrument is equipped with a printer, the ticket or label can be customised as shown in the following example.

 *Customising printouts requires advanced configuration.*

### Example of ticket/label

MARIO ROSSI SRL VIA DELL'INDUSTRIA, 20 41042 - FIORANO (MO) - ITALY WWW.MARIOROSSI.IT		Heading
WEIGH NUM. 1		Progressive weighing ticket (for accumulation modes)
GROSS 15.000 kg TARE 3.000 kg NET 12.000 kg		Weight data
TICKET NO. 54321		Progressive ticket number
05/08/2015 15:39:03		Date and time
		Bar code 39

### Example of packing list

MARIO ROSSI SRL VIA DELL'INDUSTRIA, 20 41042 - FIORANO (MO) - ITALY WWW.MARIOROSSI.IT	
WEIGH NUM. 00000001 NET 1.000 kg	
WEIGH NUM. 00000002 NET 1.000 kg	
WEIGH NUM. 00000003 NET 1.000 kg	
WEIGH NUM. 00000004 NET 1.000 kg	
TOTAL WEIGHS 00000004 TOTAL NET 4.000 kg TICKET NR. 12345 09/05/06 15:39:03	

## Swivel column (standard with some models)

To ensure maximum display reading comfort.

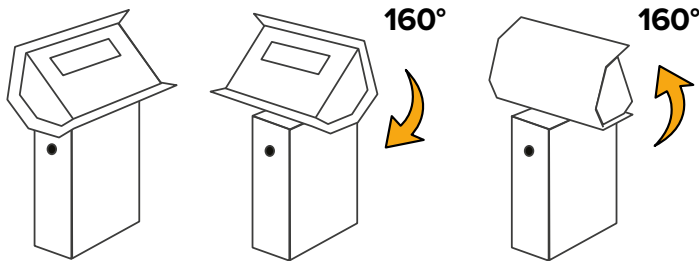

## Usb (depending on model)

USB port to store all completed weighing operations on memory stick.

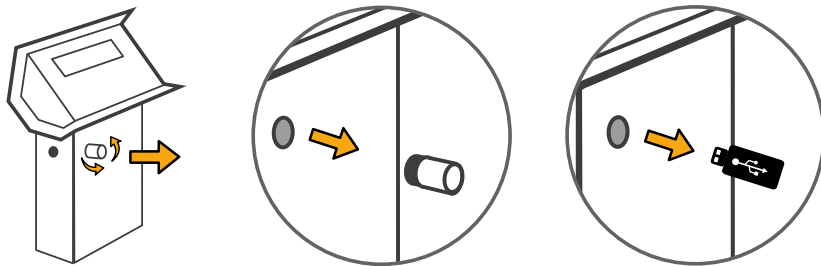

The tiller has an upright return system: be careful during manoeuvring operations.

## Antenna (depending on model)

Fixed antenna for wireless data transmission.



Do not rotate or move the antenna, its correct position is vertical.

## Brake

Pedal parking brake unit installed on tiller wheels.

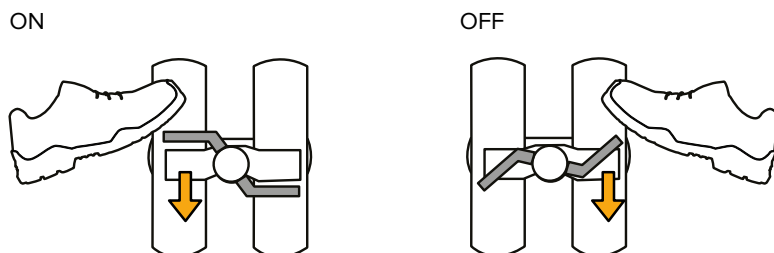

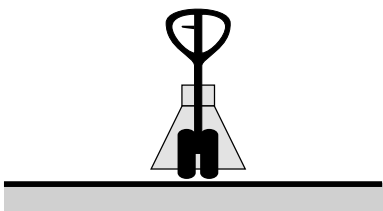
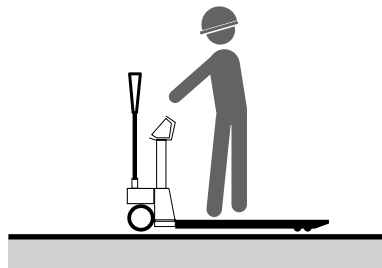
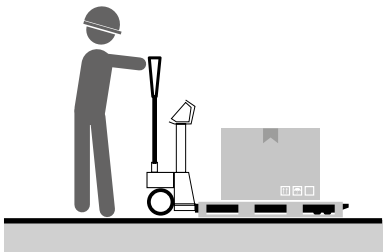
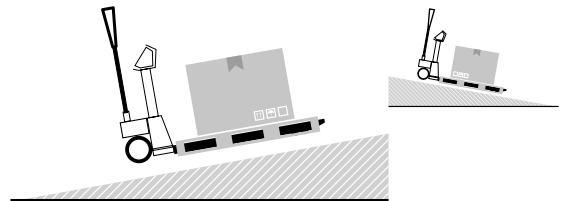
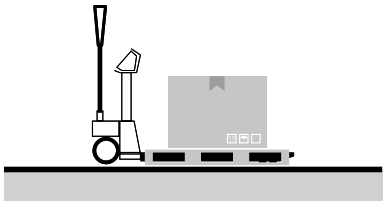

The tiller has an upright return system: be careful during manoeuvring operations.

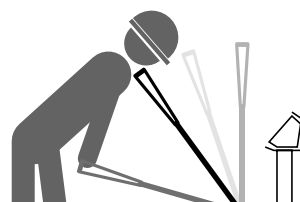

# Instructions for use

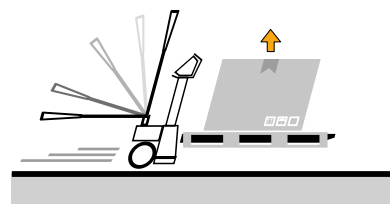
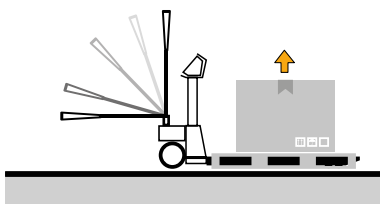
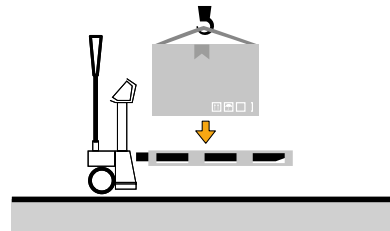
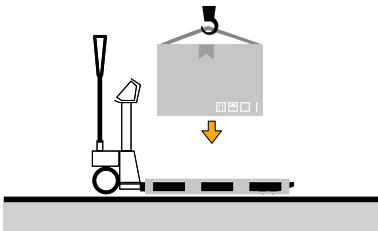
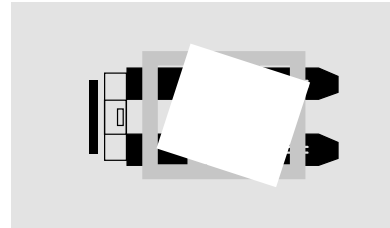
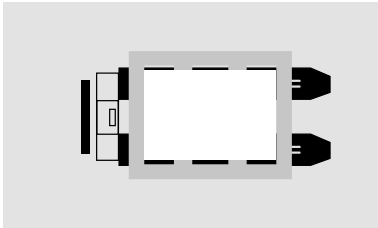
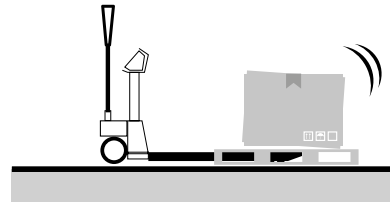
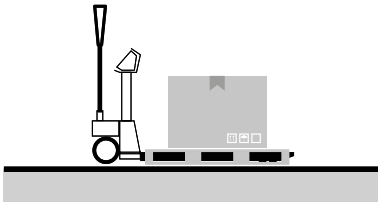

RAISE THE FORKS ONLY WHEN THE PALLET TRUCK IS STATIONARY\*



\*The pallet truck is equipped with a dual-function tiller: traction or manoeuvre and hydraulic lift.  
**NOTE:** raise or lower the pallet truck **ONLY** when stationary.

## 1 Turn on the indicator

i

Unload the pallet truck scale before turning on.

a.

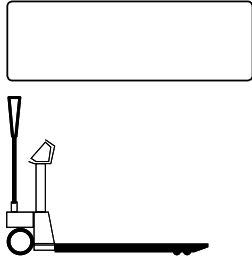

b.



c.

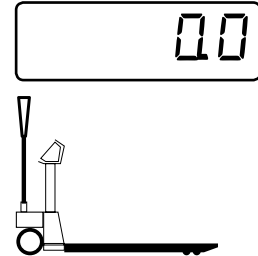

## 2 Put the pallet truck in position

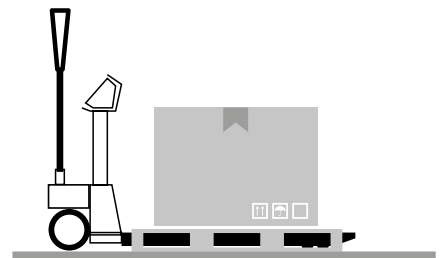
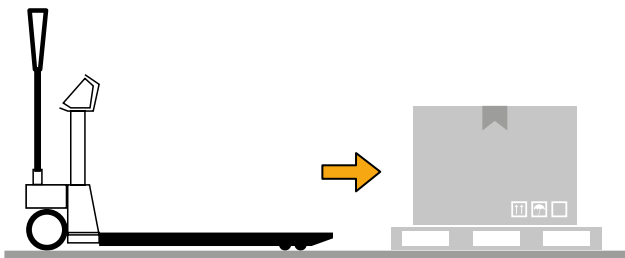

i

With approved scale, you can perform weighing on EUR EPAL pallet 800x1200mm (ref. Standards UIC 435-2 and UIC 435-4).

## 3 Lift the load and read the weight

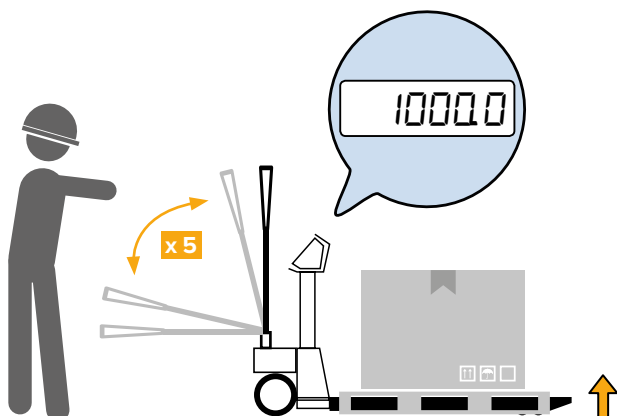

## Maintenance warnings

---

- Before proceeding with the maintenance operation ensure that the truck is in safety mode.
- During maintenance operations do not release work residues into the environment.
- Only perform the maintenance operations described herein, any unspecified procedures can pose a serious risk to untrained operators and in any case alter the machine's degree of safety.
- Always and only use original spare parts.
- During operation or maintenance, plates and stickers must NOT be removed, hidden, or made illegible.
- More complex maintenance and/or repairs must be carried out by skilled staff.

## Scheduled maintenance

---



Note that before starting maintenance operations you have to place the pallet truck on a solid surface.

---

- Ensure that the pallet truck rollers are not obstructed by dirt
- Periodically grease the bearings of the rollers and wheels
- Grease the tiller control lever guide
- Approximately every six months, check the oil level and top up with hydraulic oil IP46 if necessary. For topping up refer to the "OIL LEVEL" paragraph. N.B. When performing complete spent hydraulic oil changes, it must be disposed of in accordance with the regulations in force.
- Replace wheels and rollers when they are worn.
- In any case, for minor repairs and solutions, contact your AUTHORISED TECHNICAL ASSISTANCE

## Daily maintenance

---



Daily truck maintenance is the responsibility of the worker appointed as pallet truck operator.

---

**BELOW ARE THE CHECKS TO BE CARRIED OUT TO ENSURE OPTIMAL WEIGHING AND HANDLING PERFORMANCE:**

- Roller and wheel integrity check
- Visual check of the state of the pallet truck frame
- Weight indicator operation check
- Integrated printer operation check (where applicable)
- Pump operation check

## Regulation of the forks lowering

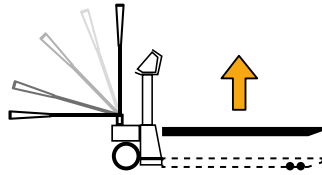
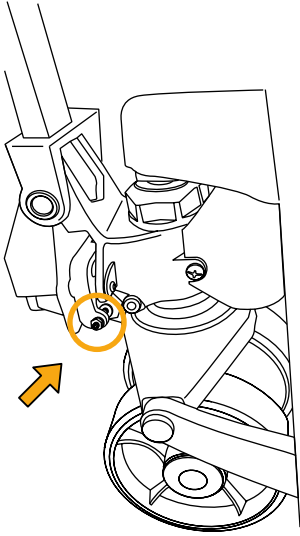

a. Place the forks at the maximum height.

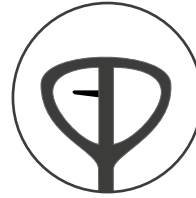

b. Place the tiller control lever in POS. 1 (centre).

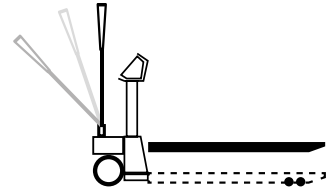

c. Make sure the tiller is in the upright position.

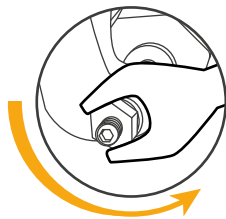

d. Unscrew the locknut, to unlock the adjustment screw.



e. Slowly turn the adjustment screw clockwise until the forks start moving downwards.

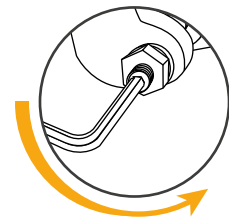

f. As soon as the forks start lowering, turn the adjustment screw one and a half turns anti-clockwise.



g. Tighten the locknut, to lock the adjustment screw.

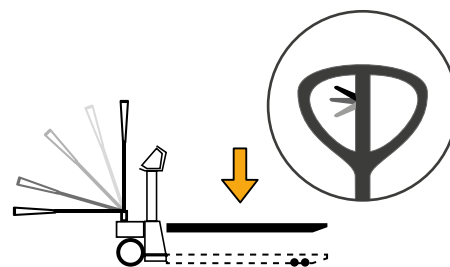

h. Using the control lever, the downwards movement can be carried out from any tiller position.



Make sure that with the tiller in its transport position, it is not possible to raise the forks. Otherwise you will need to:

- unlock the lock nut,
- turn it half a turn clockwise,
- tighten the locknut back up again.

## Oil level



Check the oil level **EVERY 6 MONTHS**.  
Only use hydraulic oil, not motor or brake oil.



**OIL VISCOSITY**  
30 CST @ 40°C  
**TOTAL VOLUME**  
0,3 LT

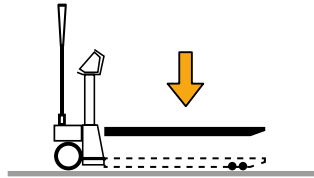
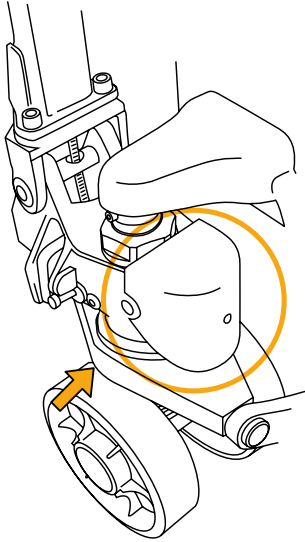

a. Lower the forks all the way.

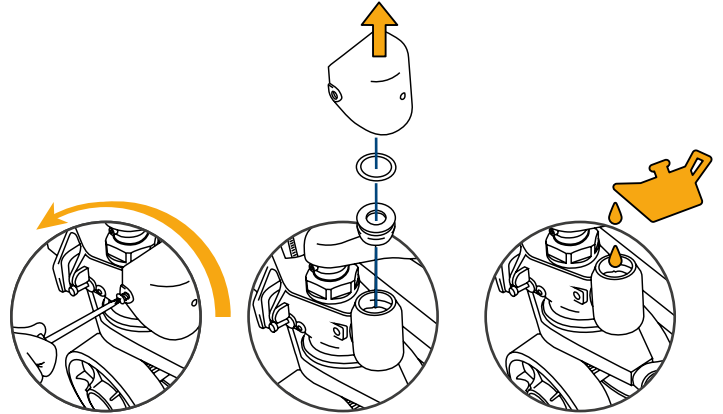

b. Remove the protective casing, the seal and the cap.

c. If necessary, add up to 20 mm from the top edge of the tank.

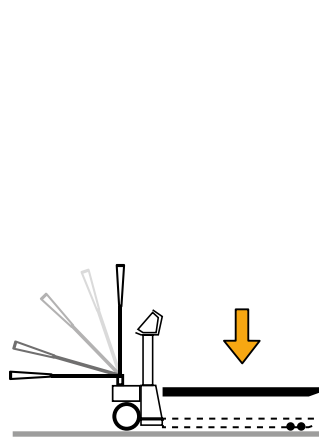

d. Operate the pump several times to release any air from the hydraulic circuit, then lower the forks completely.

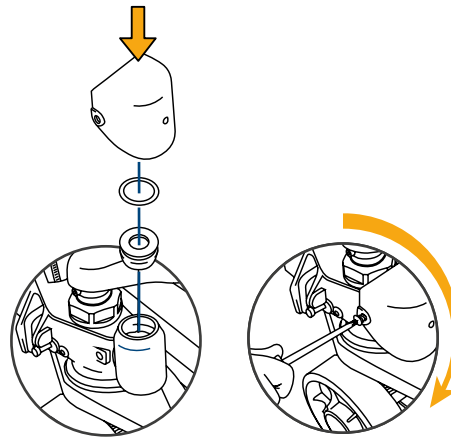

e. Put the cap, the seal and the protective casing back on.

## The display

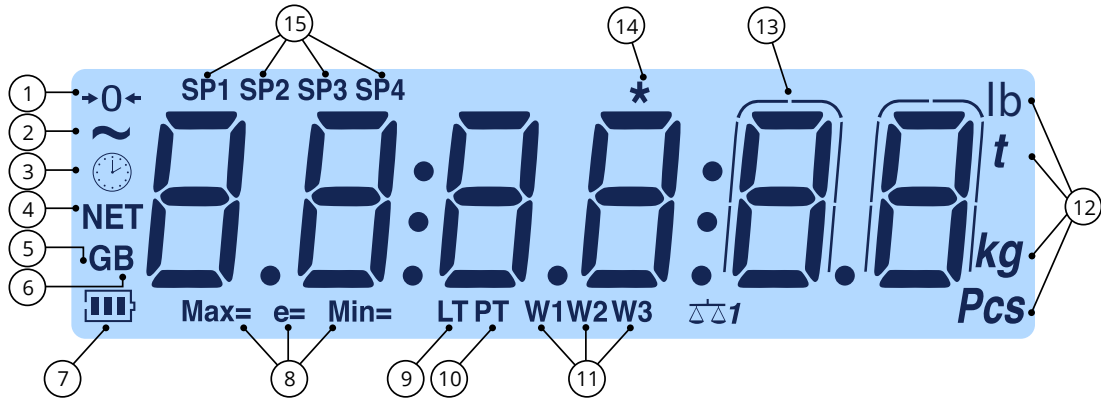

Number	Symbol	Description
(1)	→0←	The scale is unloaded and at zero (gross).
(2)	~	The weight is unstable.
(3)		The time is being shown on the display.
(4)	<b>NET</b>	The weight displayed is net. There is a saved tare.
(5,6)	<b>G B</b>	The weight displayed is gross.
(7)		Battery level.
(8)	<b>Max=Min= e=</b>	Metrics are being displayed.
(9)	<b>LT</b>	A locked tare is active.
(10)	<b>PT</b>	A manual tare is active.
(11)	<b>W1 W2 W3</b>	Indicate the range of active weighing.
(12)	lb ... Pcs	Units of measurement - Pounds (lb), tonnes (t), kilograms (kg), grams (g), number of pieces (Pcs).
(13)		The weight is being displayed in high resolution.
(14)	*	This means a key is pressed. In some operating modes, it means that a specific function is active.
(15)	<b>SP1...SP4</b>	These indicate the active relay ports (only with the optional board).

LETTERS:

A	B	C	D	E	F	G	H	I	J	K	L	M	N	O	P	Q	R	S	T	U	V	W	X	Y	Z
a	b	c	d	e	f	g	h	i	j	k	l	m	n	o	p	q	r	s	t	u	v	w	x	y	z

NUMBERS:

0	1	2	3	4	5	6	7	8	9
0	1	2	3	4	5	6	7	8	9

## On

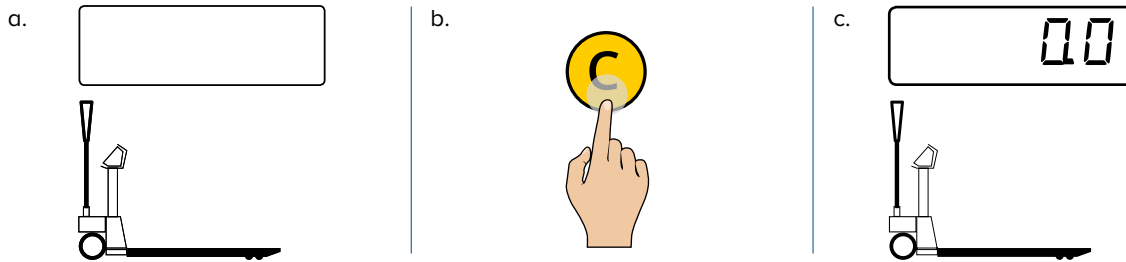

## Off

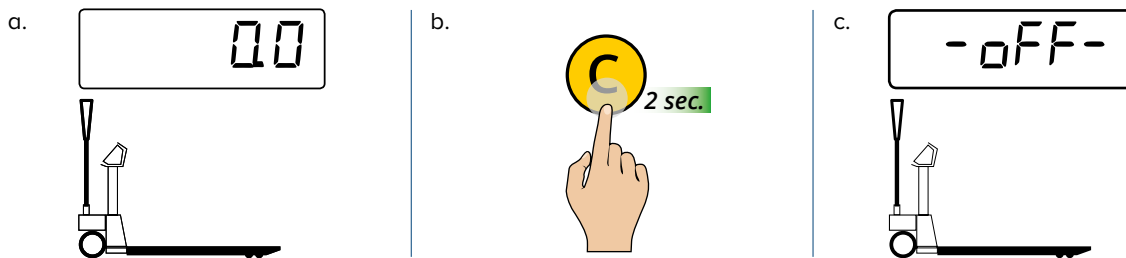

## Zero

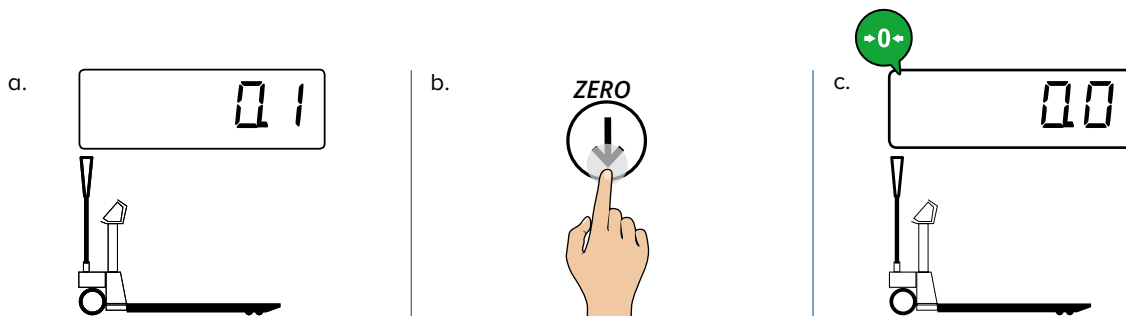

## Regulation of the display brightness

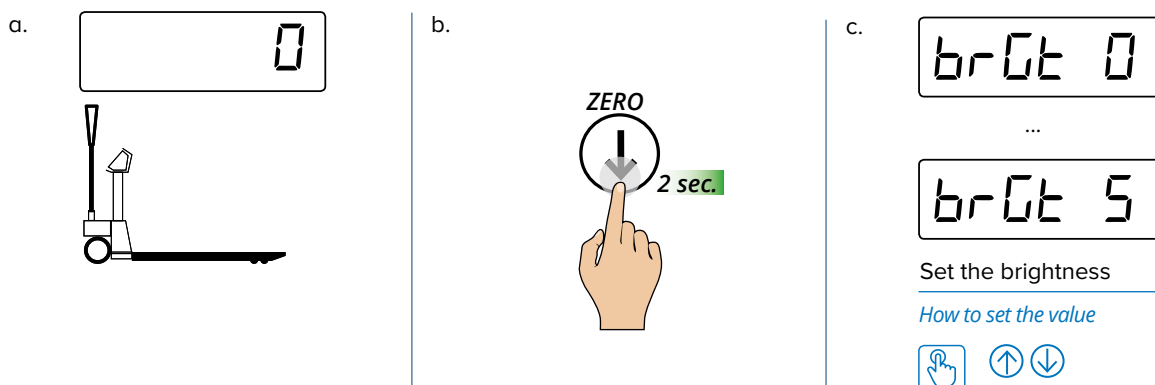

## Automatic tare

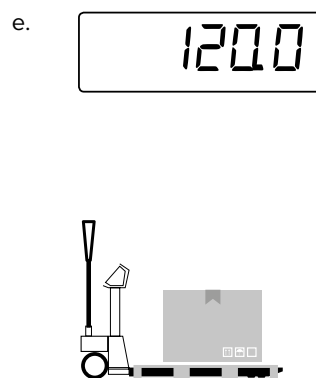
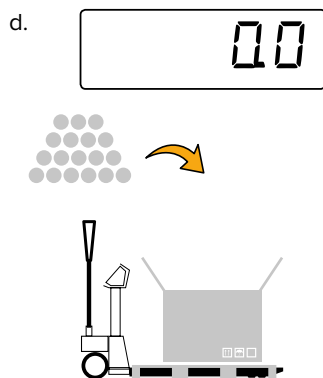
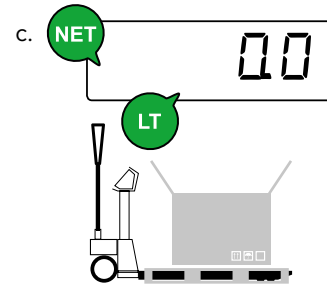
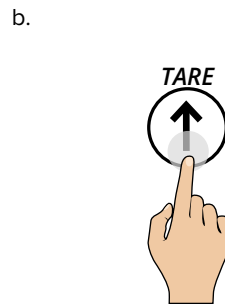
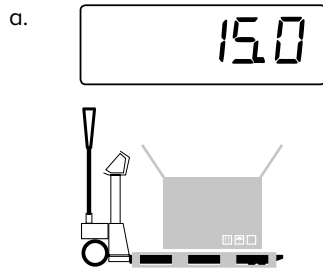
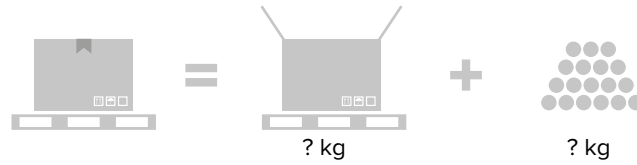

## Tare deletion

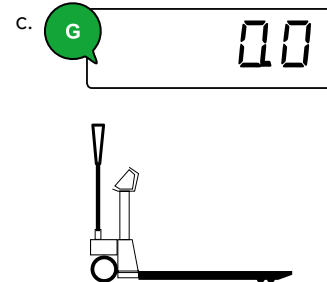
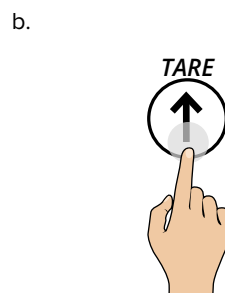
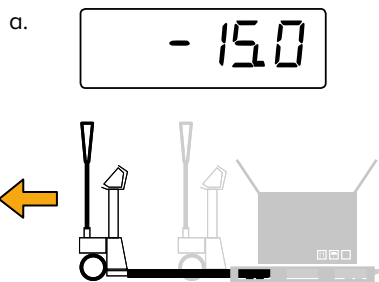

## Presetable tare (PT)

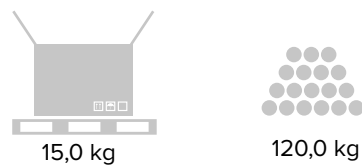
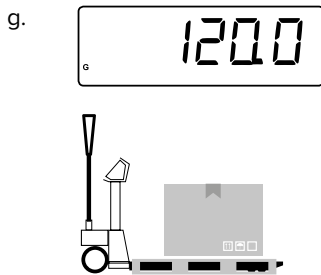
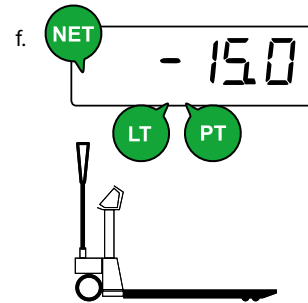
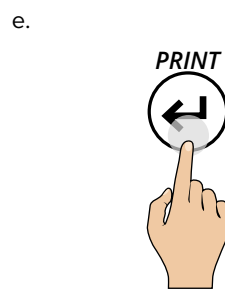
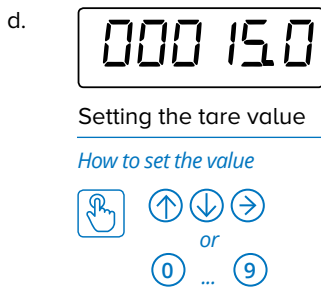
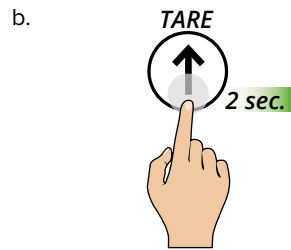
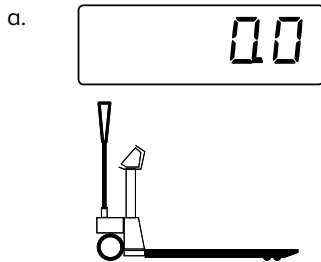
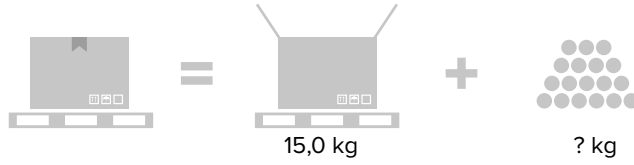

If the pallet truck has a number keypad, it is possible to enter the tare quickly:

a. Enter the tare value

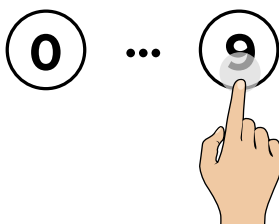

b.



**Print (and reprint of the last ticket)**

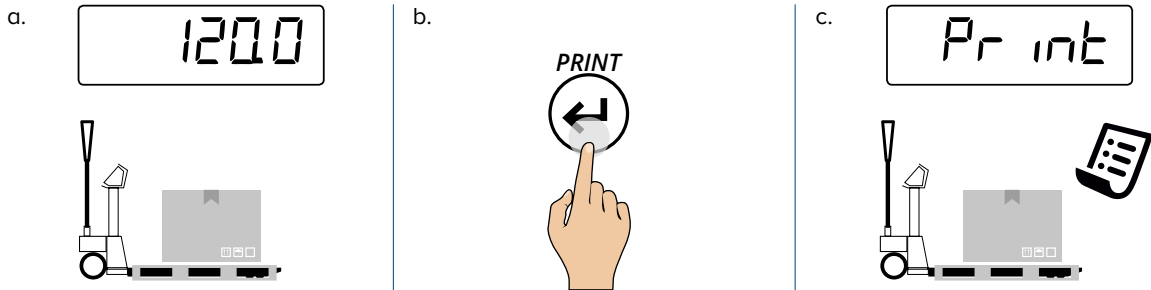

To reprint the last ticket (for models with number keypad)

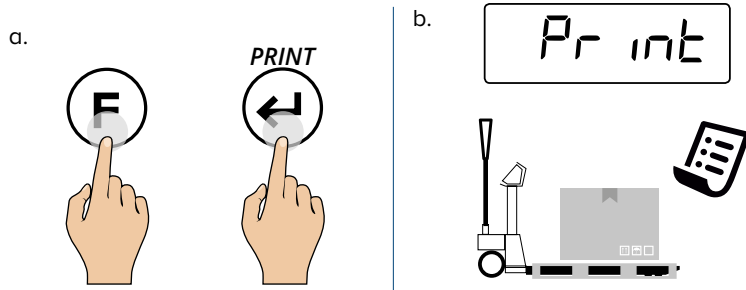

**Metrics**

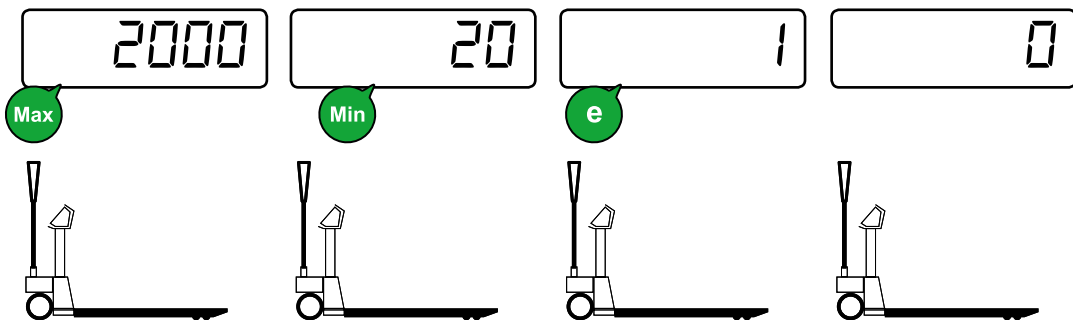
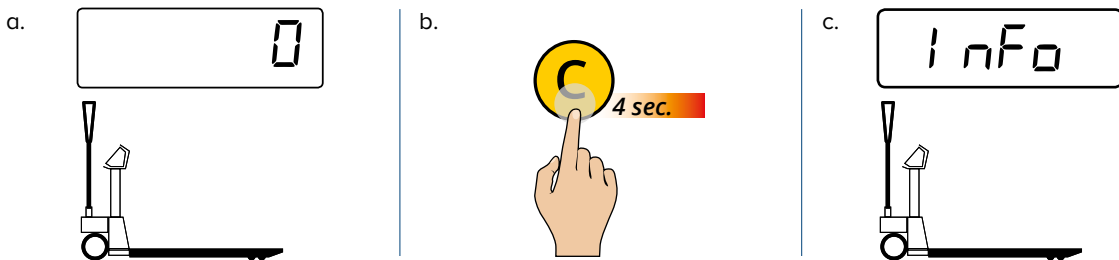

## 30-tare memory

This memorises the most commonly used tares (up to 30), to simplify retrieval with quick selection.

### Example

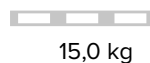
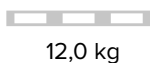
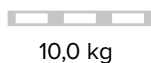

### How to store a tare

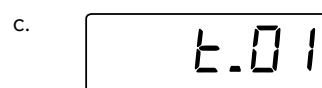
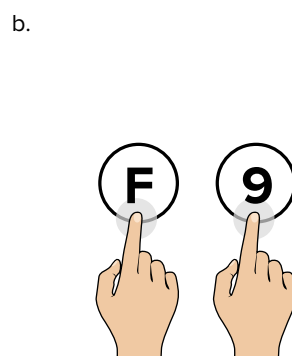
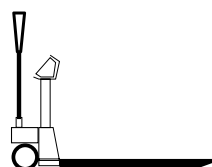

Select the memory.

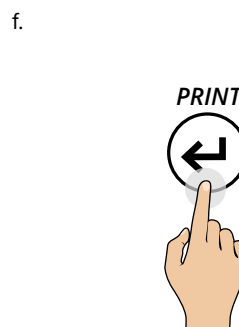
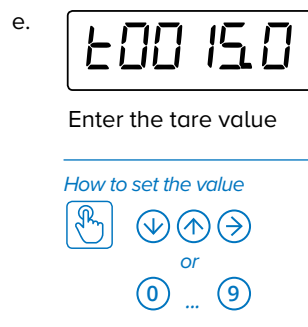
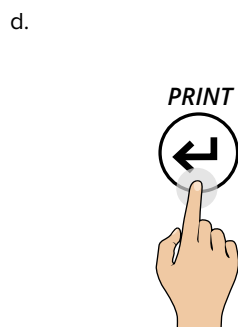

## How to retrieve a stored tare

a.

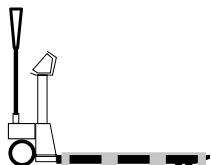
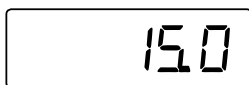

b.

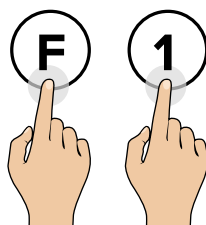
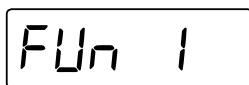

c.

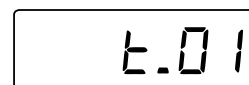

Select the memory.

How to set the value



d.



e.

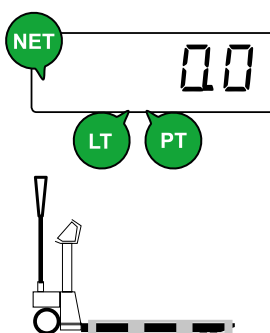

## Automatic tare deletion

a.

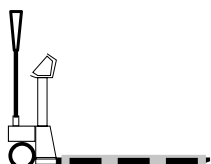
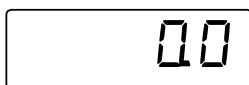

b.

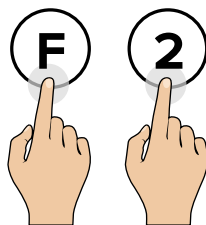
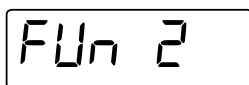

c.

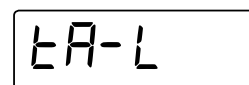

Automatic deletion disabled

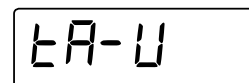

Automatic deletion enabled: the tare will be deleted automatically when the pallet truck is completely unloaded.

## Number IDs

The instrument is fitted with 2 memories for the temporary registration of numerical codes that can be used to identify the product, the operator, the lot etc... These codes, if entered, will be present in the ticket when printing.

### Come inserire l'ID

a. 

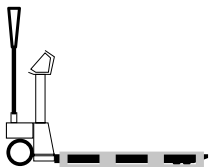

b. 

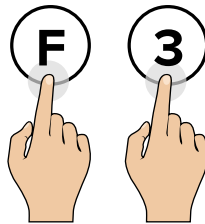

c. 

Select the memory.

How to set the value

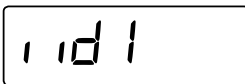

d. 



e. 

Enter the required ID  
(up to 10 digits)

How to set the value



f. 



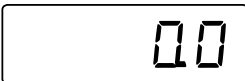

### How to enable automatic ID deletion

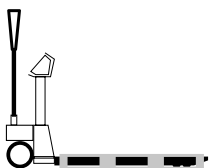
a. 

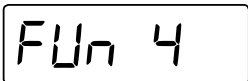

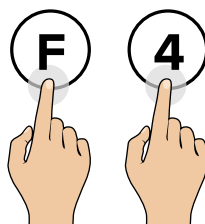
b. 



c. 

Select the memory.

How to set the value

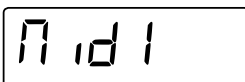

d. 

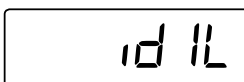

e. 

Automatic deletion disabled.

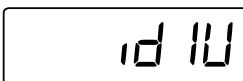

Automatic deletion enabled: the entered ID will be deleted automatically when the pallet truck is completely unloaded.



The numerical IDs zero automatically when turning off the scale.

## Date and time

a.

00

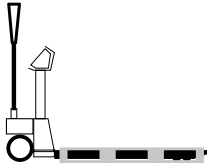

b.

FUn 8

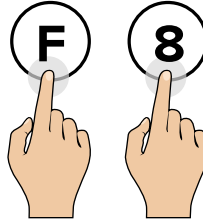

c.



dAY

Month

YEAr

hour

Minute

i

Only if the option date and hour is present.

## How to access the function menu

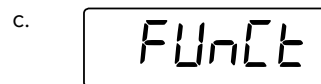
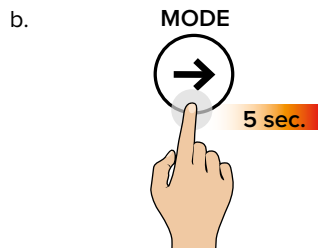
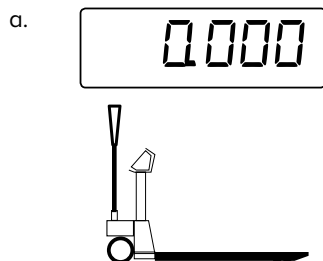

The indicator is in the function menu: the currently active function appears.

d. Select function

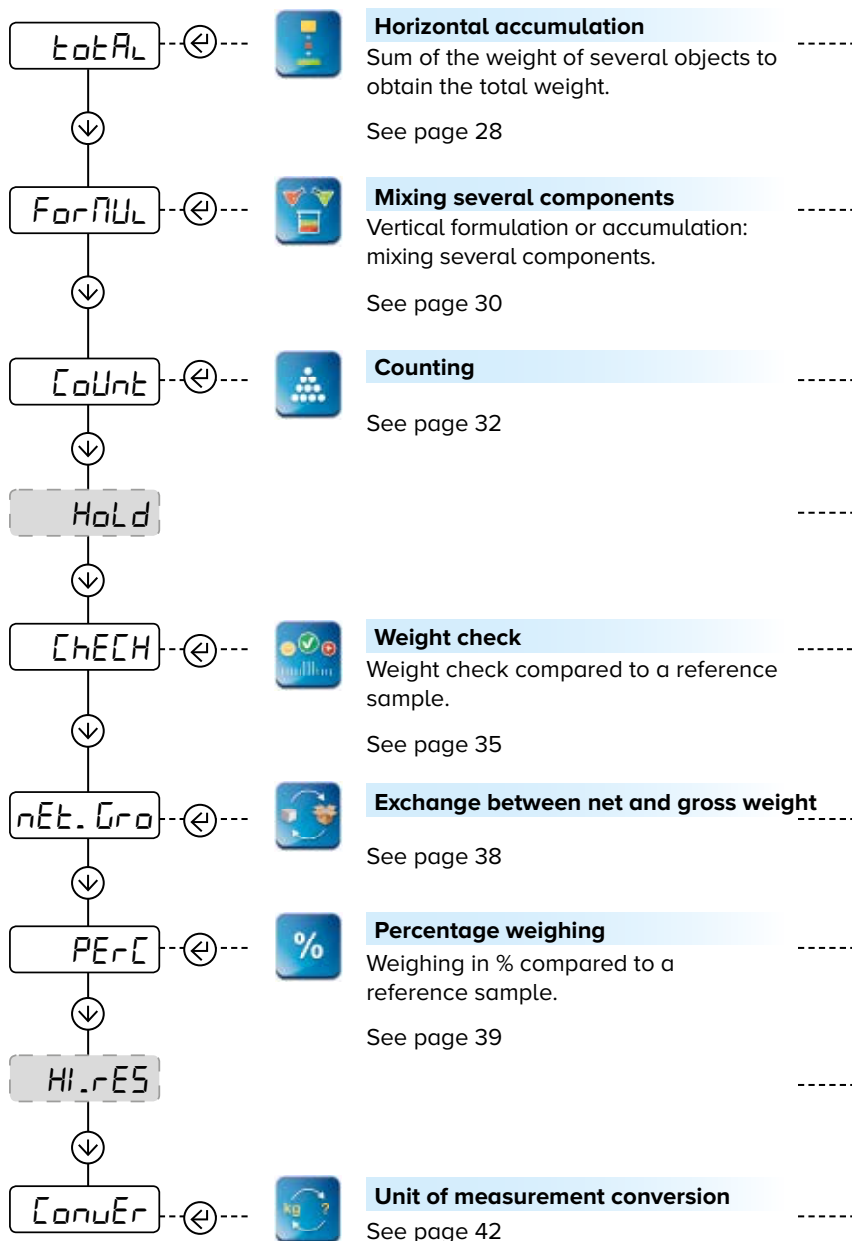

Once you have selected the function, the scale goes back to weighing mode.

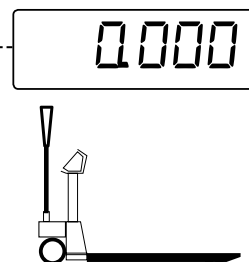



## Horizontal totalization

### How to sum the weighs

a.

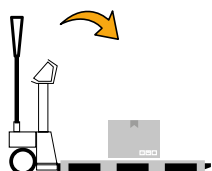

b.

c.

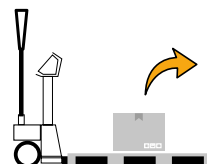

d.

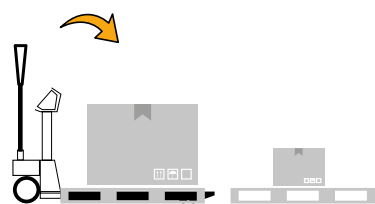

e.

f.

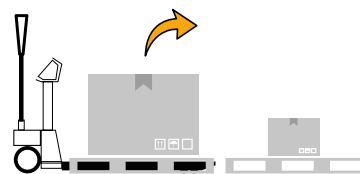

g.

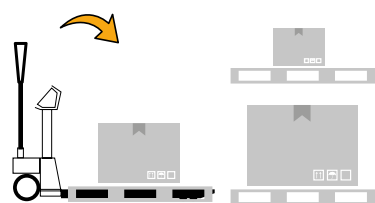

h.

i.

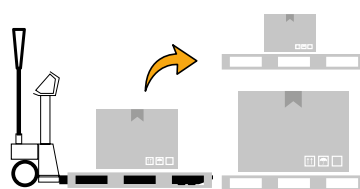



## How to momentarily read the total

a. 

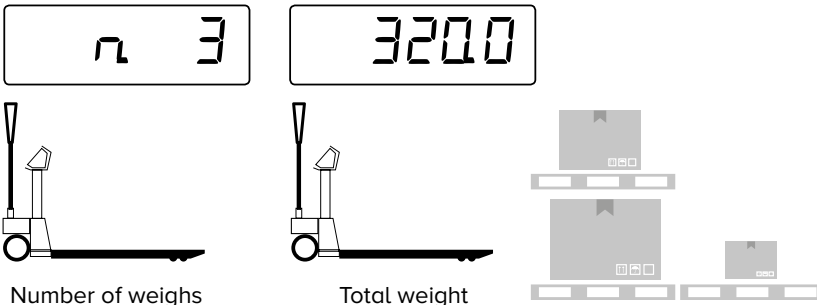
b. 



With number keyboard, the combination of (F) keys + (7) displays the current total without printing it/resetting it.

## How to end accumulation and reset the total

a. 

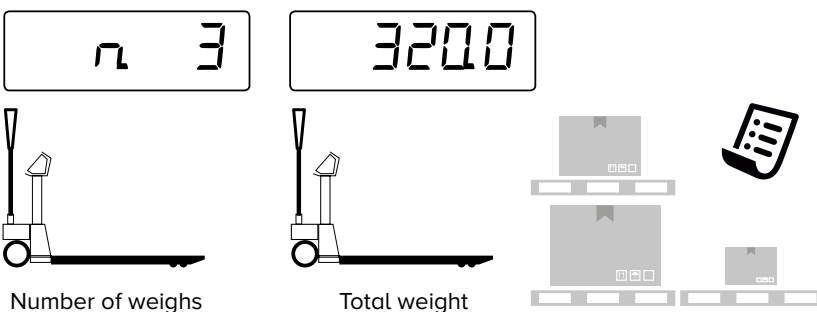
b. 



With number keyboard, the combination of (F) keys + (7) displays the current total without printing it/resetting it.

## How to print and reset the grand total

a. 

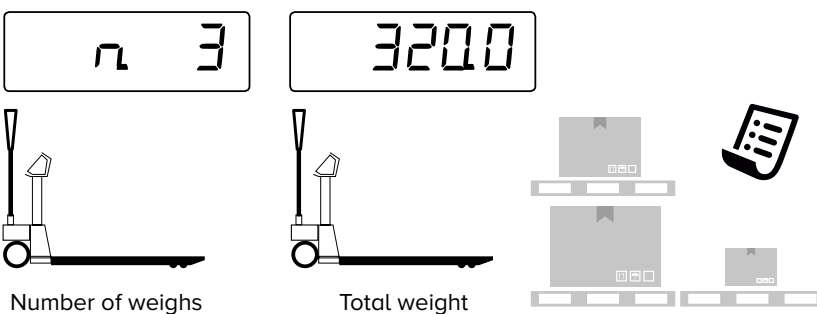
b. 



With numerical keyboard, (F) + (6) simply shows the current total without any printout/reset.



## Mixing several components

### How to sum the weighs

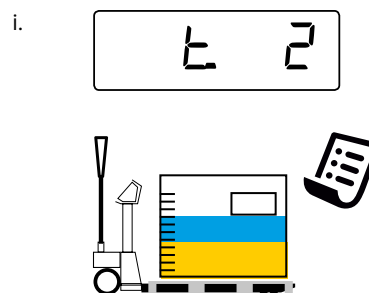
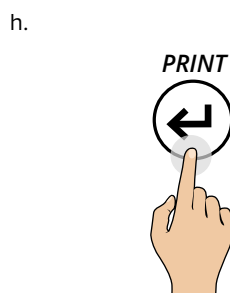
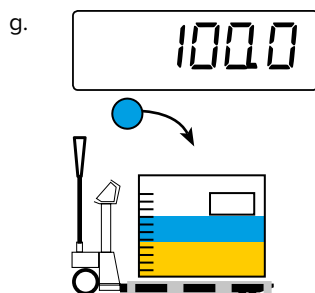
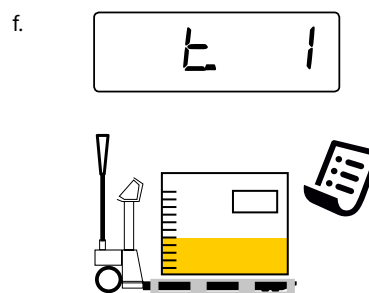
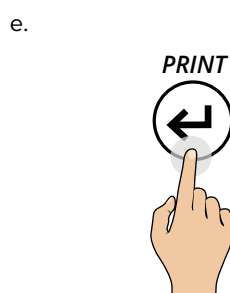
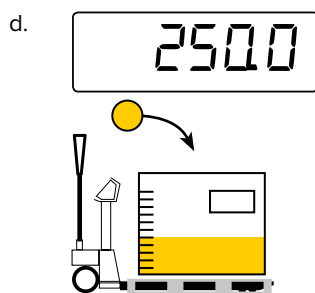
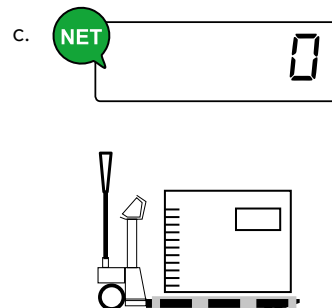
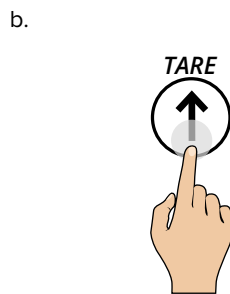
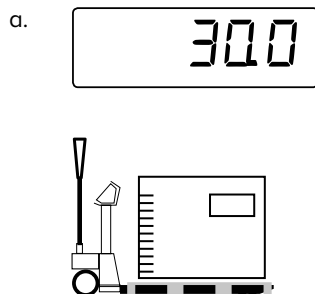



## How to momentarily read the total

a. 

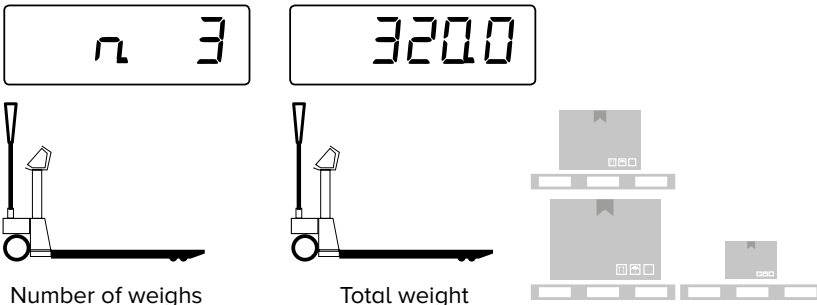
b. 



With number keyboard, the combination of (F) keys + (7) displays the current total without printing it/resetting it.

## How to end accumulation and reset the total

a. 

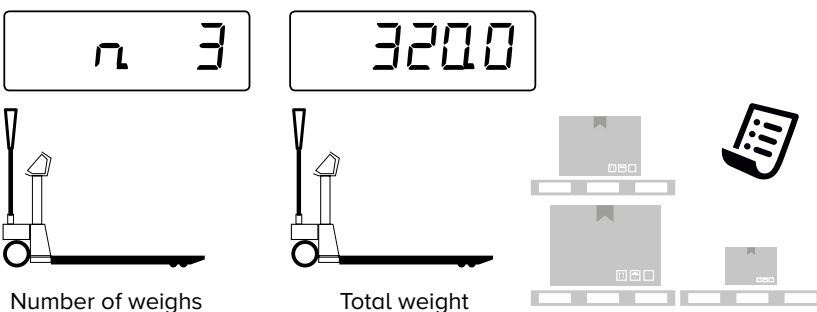
b. 



With number keyboard, the combination of (F) keys + (7) displays the current total without printing it/resetting it.

## How to print and reset the grand total

a. 

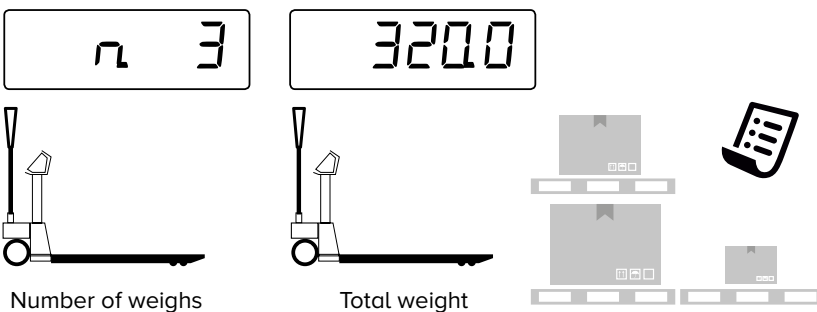
b. 



With numerical keyboard, (F) + (6) simply shows the current total without any printout/reset.



## Pieces counting

### How to sample and count

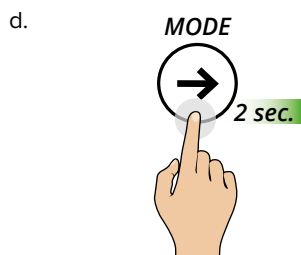
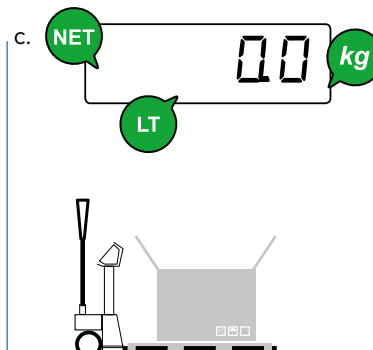
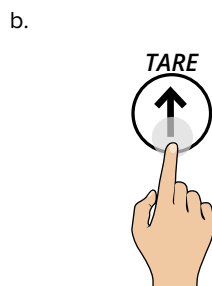
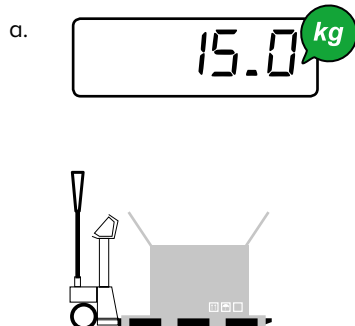

*\*If the pallet truck scale is already in counting mode (active sampling), in order to sample again press the key for 2 seconds.*

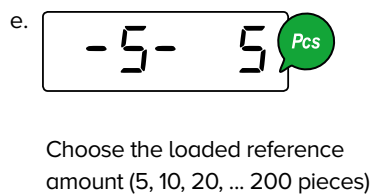

*How to set the value*



*With the numerical keyboard, the combination of the **F** + **5** keys allows to type the desired quantity (in any amount)*

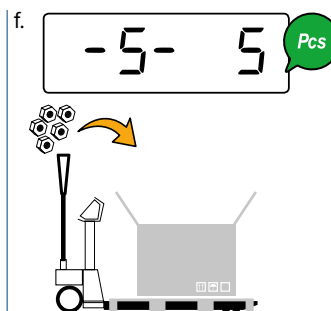

Load the desired reference quantity (e.g. 5 pieces).  
*For a correct sampling, the reference quantity must have a weight of at least 0.1% of the maximum scale capacity.*

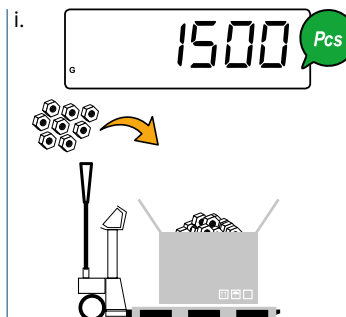
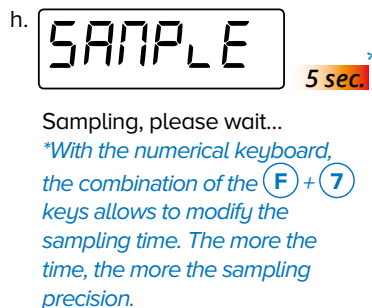
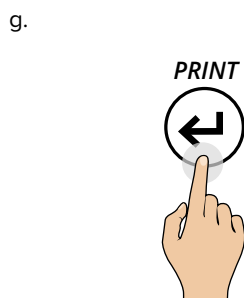



## How to switch from piece to weight display and vice versa

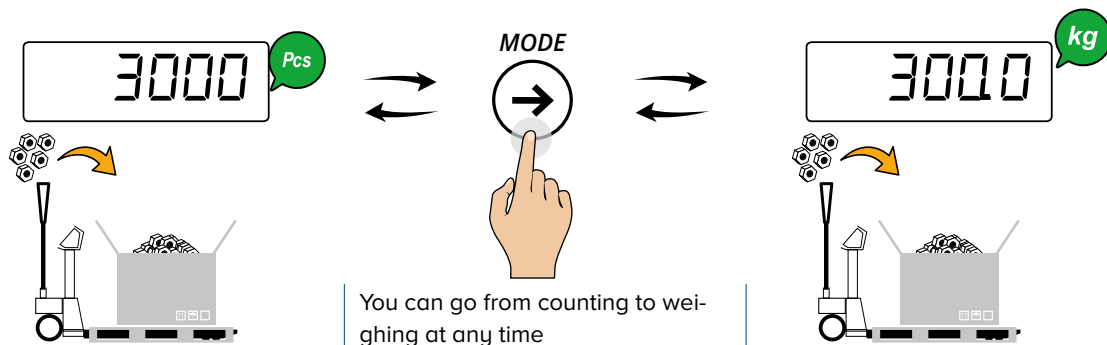

## How to enter the average unit weight (PMU)

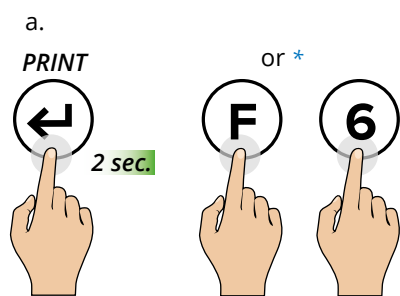

\* With the numerical keyboard, it is possible to use the rapid combination **F** + **6**.

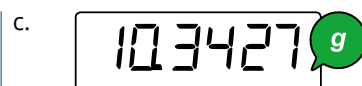
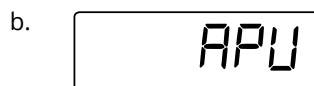

Enter the average unit weight

e.g. = = 10,3427g

How to set the value

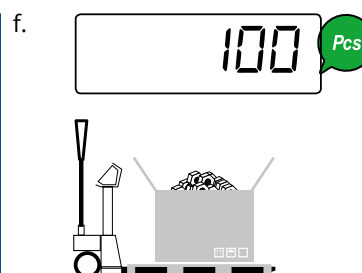
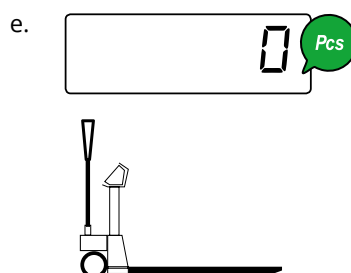
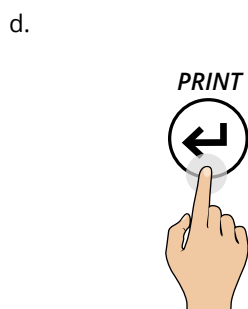

For correct counting, you must set the known tare value (see page 21) or tare the empty container and fill it with the pieces to count.



## Pieces counting

### Total load count

a.

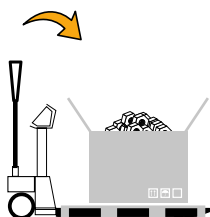

b. Manually set the tare value (pallet + container)

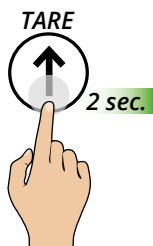

How to set the value



c.

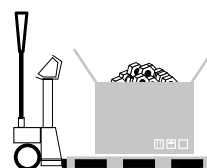

d.

e.

Select the desired reference quantity (5, 10, 20, ... 200 pieces)

How to set the value



Using the number keyboard, pressing (F) + (5) allows you to type in any amount.

f. Pick up the sampling pieces (5, 10, 20, 30, 40, 50, 60, 75, 100, 200 pieces).

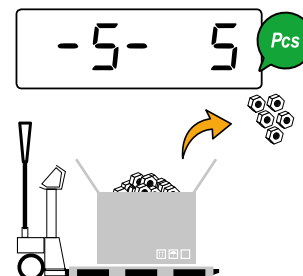

g.

h.

Sampling, please wait...

\* With the numerical keyboard, the combination of the (F) + (7) keys allows to modify the sampling time. The more the time, the more the sampling precision.

i.

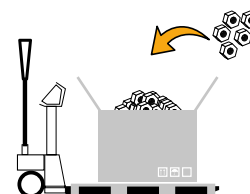



## Weight check

### How to start the check with known reference weight

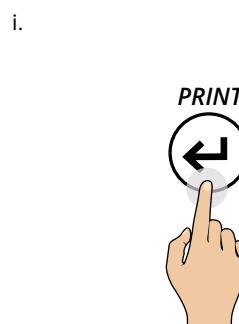
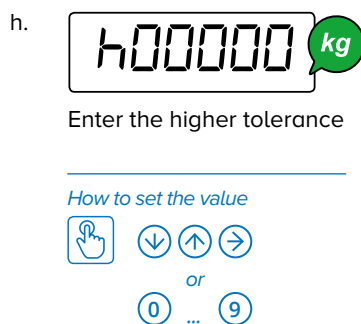
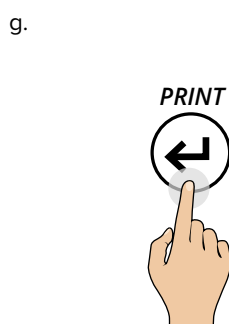
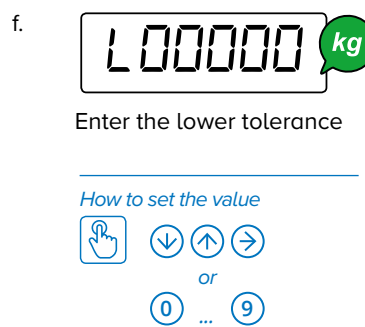
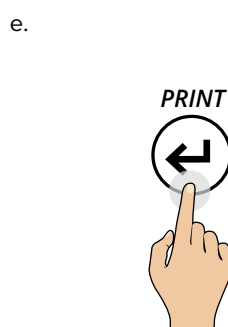
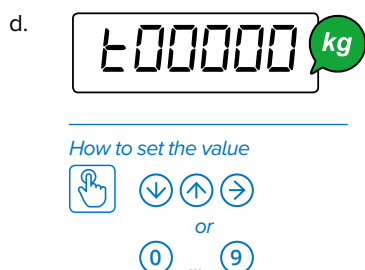
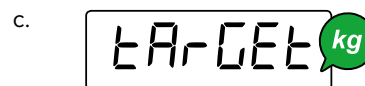
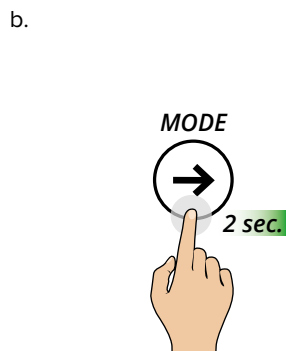
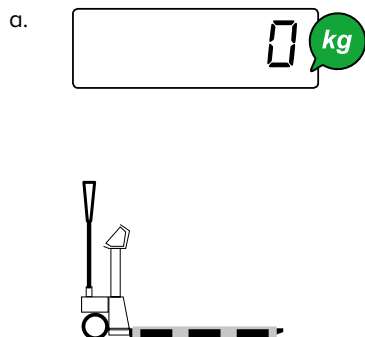

#### Example 1

To check a weight of 1000 g with +/- 5 g tolerance (that is, between 995 g and 1005 g), set:

L0 1000  
L 00005  
H00005

#### Example 2









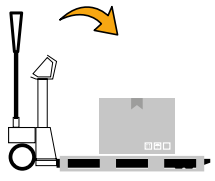

To check a weight of 500 g with + 10 g / - 20 g tolerance (that is, between 480 g and 510 g), set:

L00500  
L 00020  
H000 10



## Weight check

### How to start the check with automatic target acquisition

- a.  
- b.  **MODE**  
2 sec.
- c.  **kg**  
Enter the lower tolerance  
*How to set the value*  
  
or  

- d.  **PRINT**
- e.  **kg**  
Enter the higher tolerance  
*How to set the value*  
  
or  

- f.  **PRINT**

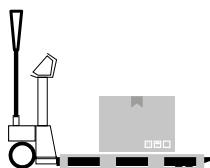
### How to check the weight

- oH -

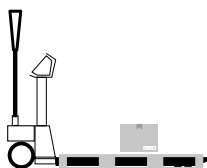

\_UndEr



OvEr

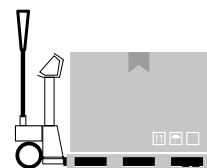



## Weight check

### How to update the nominal weight with known reference weight

- 
- 
- 

### How to update the nominal weight with automatic target acquisition

- 
- 

### How to edit the check thresholds

- 
- 
- 
- 
-



## Exchange between net weight and gross weight

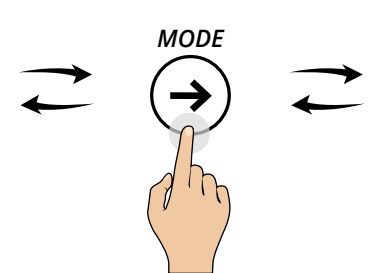
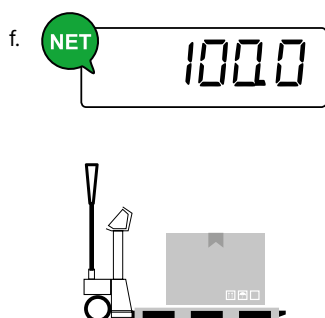
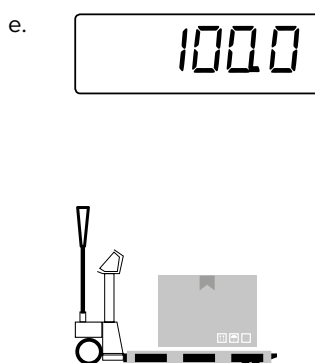
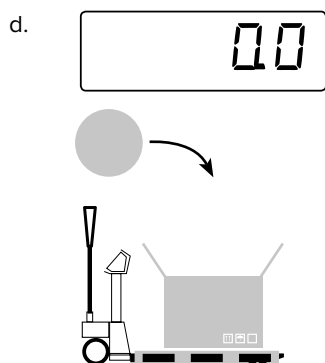
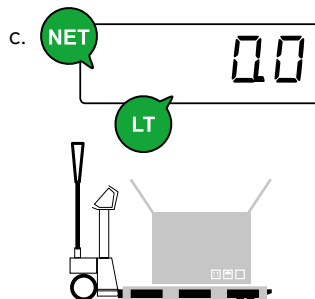
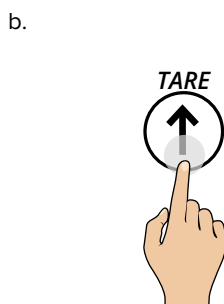
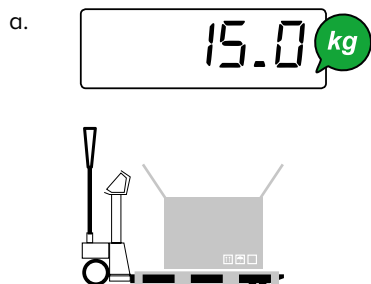

You can go from net weight to gross weight at any time.

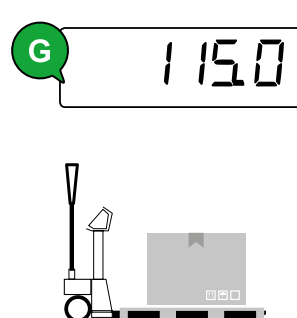



## Percentage weighing

### Percentage check

#### I. How to acquire the 100% reference

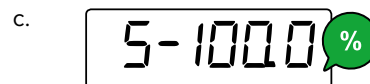
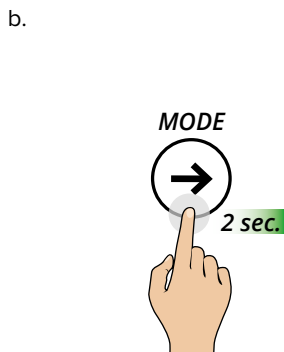
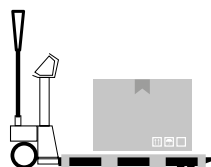
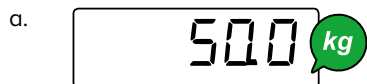

How to set the value

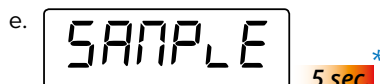
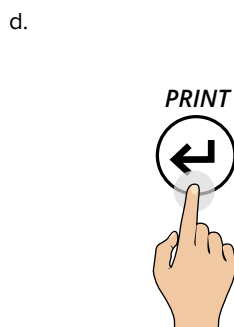

Sampling in progress, please wait...  
 \* With the numerical keyboard, the combination of the **F** + **7** keys allows to modify the sampling time.  
 The more the time, the more the sampling precision.

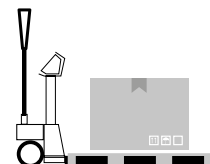
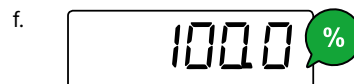

#### II. How to check the weight

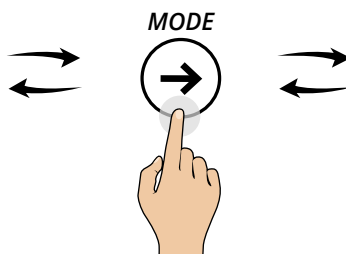
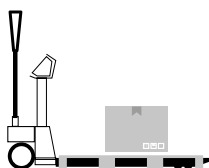
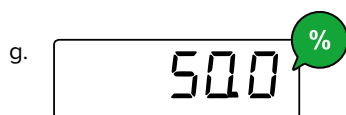

You can go from weight in % to weight in kg at any time.

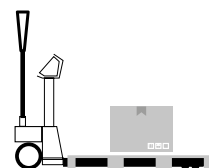
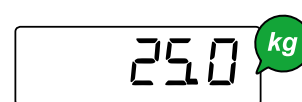



## Percentage weighing

### Percentage metering

Example of formula

**Product: RP28K**

1. 2127A3 - 50%
2. 23AB4 - 30%
3. Water - 20%

**Dose 500 kg**

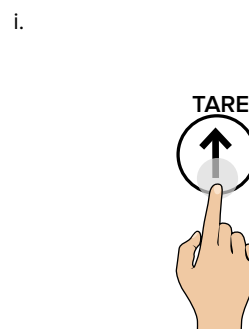
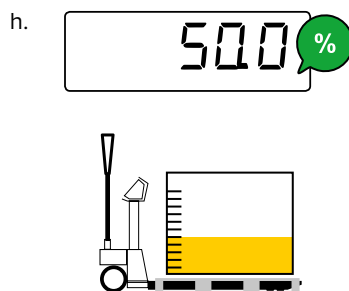
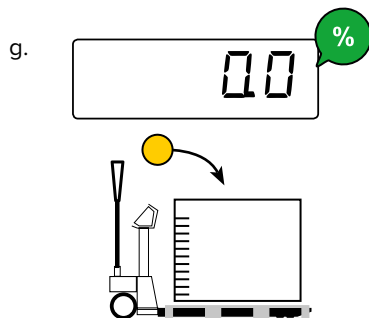
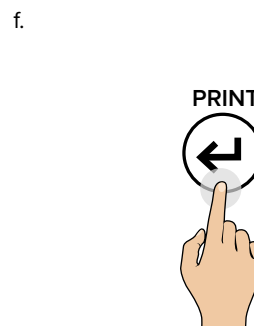
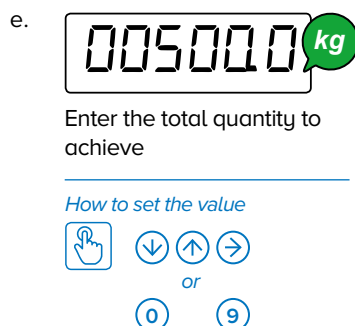
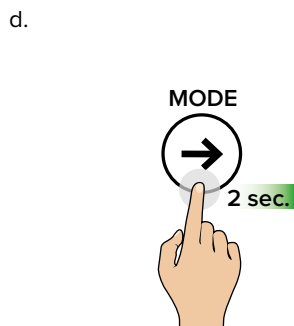
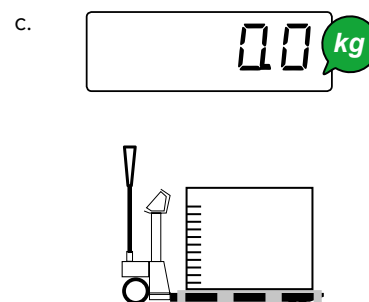
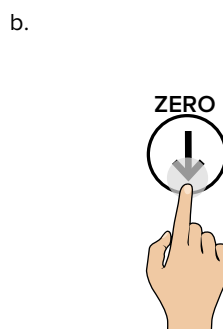
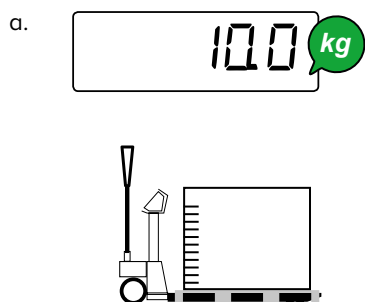



Percentage weighing

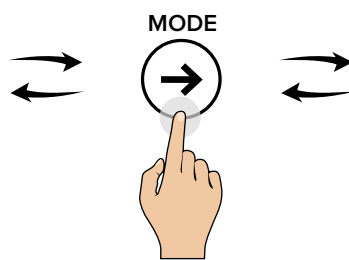
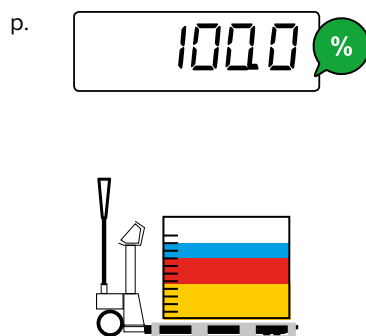
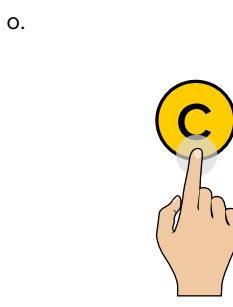
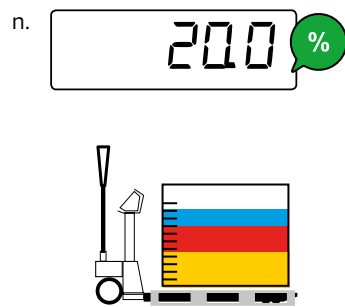
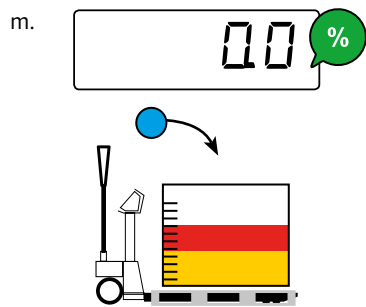
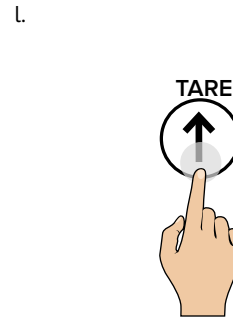
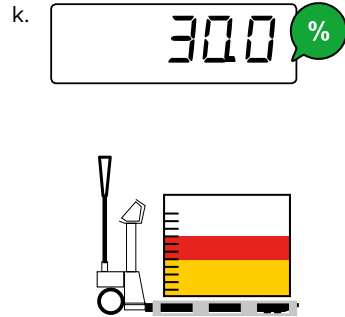
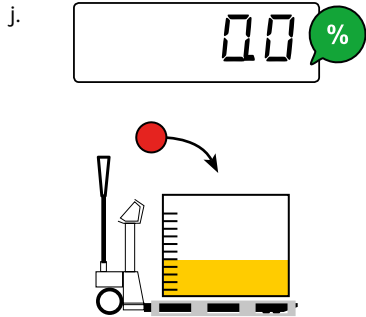

You can go from weight in % to weight in kg. at any time.

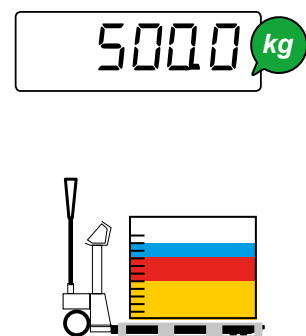



## Unit of measurement conversion

### How to convert the unit of measurement into pounds (standard mode)

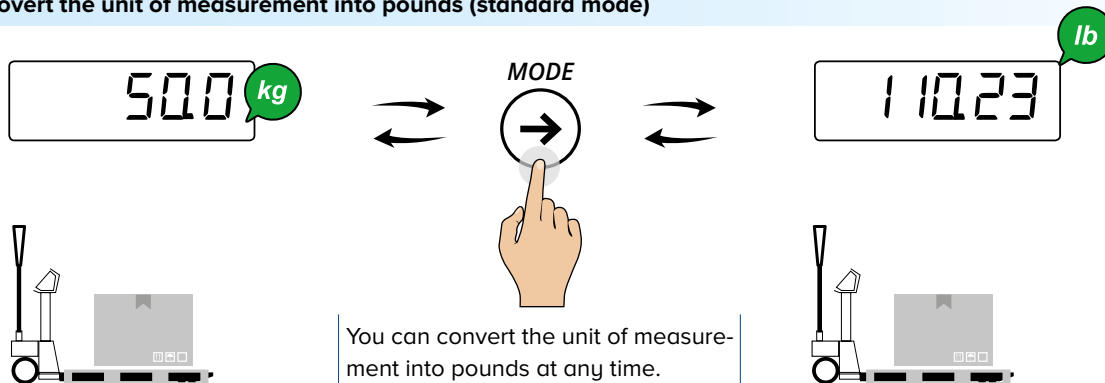

### Converting the unit of measurement with free conversion factor

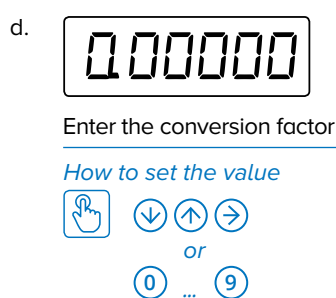
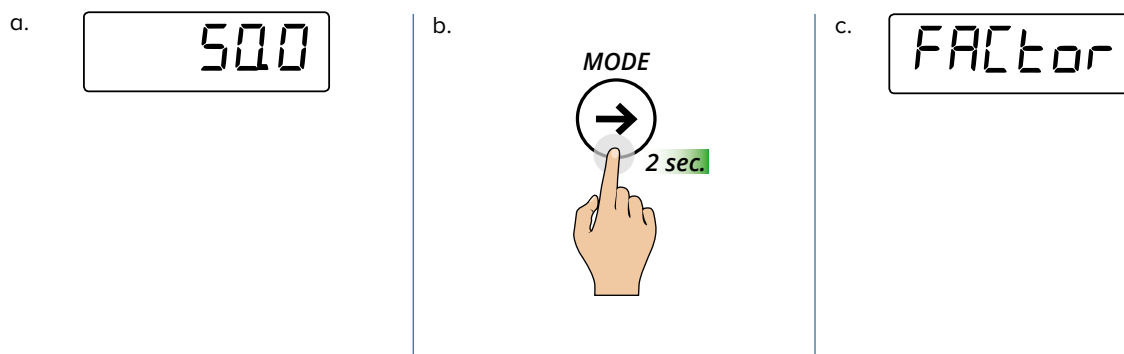

**Examples:**

Pounds (lb)	1g = 0.00220
Ounces (oz)	1g = 0.03527
Stone (st)	1g = 0.00016
Carats (kt)	1g = 5.00000
Grains (gr)	1g = 15.43240
...	

*Any conversion factor must be multiplied to the weight.*

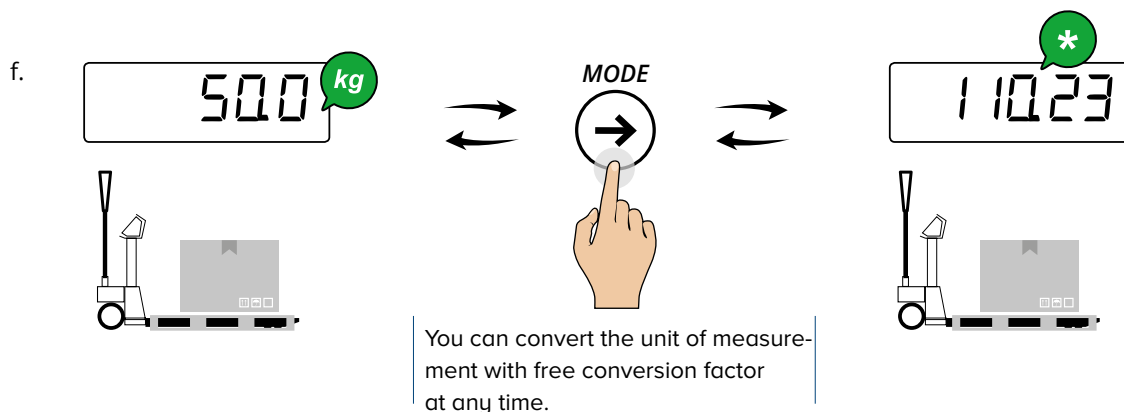
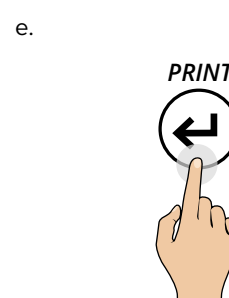

## Identification of the metrological software

### 1. Turn off the scale

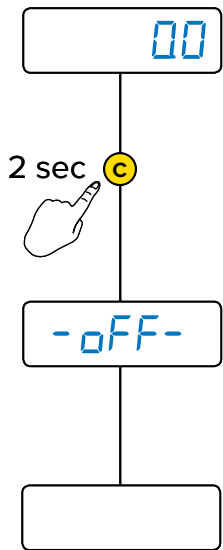

### 2. Follow the procedure:

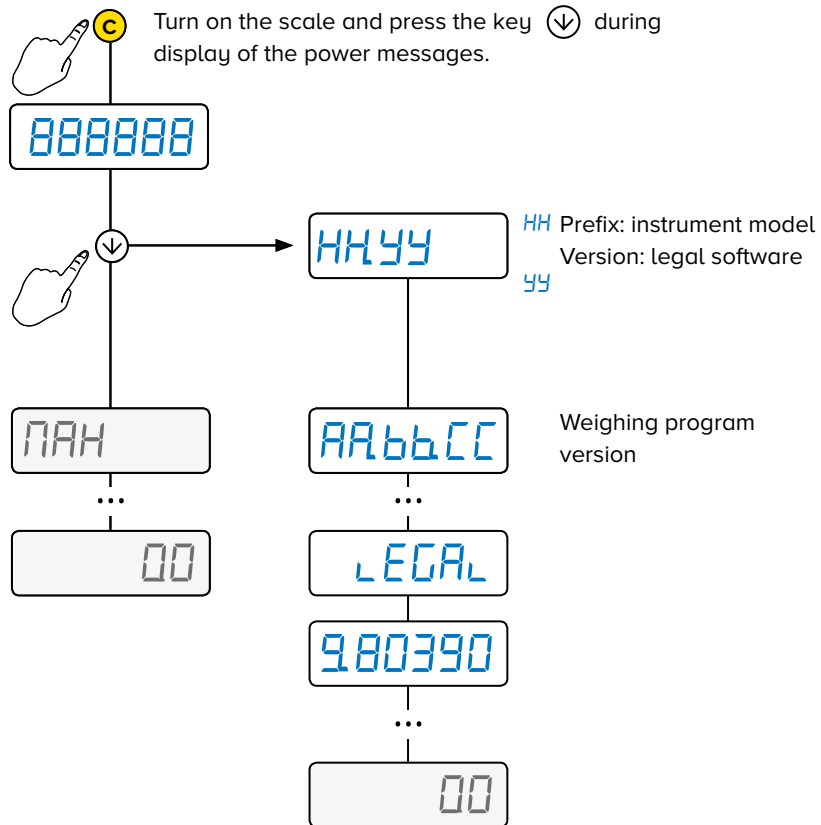

## Print

---

### The scale does not print

- Another printout is already in progress (bU54)
- Make sure there is a roll in the printer
- The printer does not switch on
- The weight is unstable (UnStAb)
- The net or gross weight is negative or insufficient for printing (LoW)
- Underload or overload (\_\_\_\_ or \_\_\_\_\_) (Un. oUEr)
- The scale was not unloaded after the last printing (no. 0. Un5)
- You are trying to print a non-approved weight

## Totalization

---

### The scale does not accumulate

- Make sure there is a roll in the printer
- The printer does not switch on
- The weight is unstable (UnStAb)
- The net or gross weight is negative (LoW)
- Underload or overload (\_\_\_\_ or \_\_\_\_\_) (Un. oUEr)
- The scale was not unloaded after the last printing (no. 0. Un5)
- The weight is too low for the weighing operation (LoW)
  - less than 10 divisions for the accumulator modes
  - less than "Min" for the approved products (shown on the measuring plate)

### The sale has lost the total

- Switching off the scale causes the accumulated totals to be lost

## Tare

---

### The scale does not tare

- The weight is unstable (UnStAb)
- The gross weight is negative (LoW)
- The weight is insufficient
- The weight exceeds the maximum capacity
- The tare function has been deactivated
- In the event of manual tare, the value exceeds the maximum capacity

## Weighing

---

### The scale does not switch on

- Make sure the power cable is connected properly
- Connect the battery charger and try again. If the instrument continues to malfunction, contact the dealer.

### The scale switches off suddenly

- Automatic switching off active
- Low battery
- Battery failure
- Power supply line failure

### The scale is not reactive

- One of the available energy saving modes has been activated
- An unsuitable weighing filter has been selected

### The scale display switches off and displays a dot

- Stand-by mode is active: press a key to reactivate weighing.
- Energy saving mode is active: contact the dealer for further details.

### The scale displays a permanent “Err” message

- The scale is unable to automatically reset the weight because it exceeds the maximum resettable weight at switch-on.
- Unload the scale and try again. If the scale continues to have the same problem even when there is nothing on it, contact the dealer.

### The weight is unstable

- Check whether the weighing filter is active.
- If the support surface is subjected to vibrations from machinery or moving vehicles, move the scale onto another surface and try again.

## Pieces counting

---

### The scale does not carry out sampling

- The weight is unstable (*Err. nat*)
- The weight is insufficient, add more pieces and try again (*Error*)

MESSAGE	DESCRIPTION	SOLUTION
<i>buSy</i>	Another printout is already in progress	Wait for the printout in progress to be finished and try again.
<i>UnStAb</i>	The weight is unstable	Check the weighing filter. If the support surface is subjected to vibrations from machinery or moving vehicles, move the scale onto another surface and try again.
<i>LoW</i>	Net or gross weight is negative or insufficient for printing	Add weight and try again.
<i>Un. ouEr</i>	Underload or overload (____ o _____)	Completely unload the scale, making sure $\Delta$ lights up. Load the weight on again and try again.
<i>no. 0. UnS</i>	The scale was not unloaded after the last printing	Completely unload the scale, making sure $\rightarrow 0 \leftarrow$ lights up. Load the weight on again and try again.
<i>Err. Not</i>	The weight is unstable	Wait for stability (the $\sim$ light) and try again.
<i>Error</i>	In pieces counting mode, the weight is insufficient for proper sampling.	Add more pieces and try again.
<i>tilt</i>	Angle error.	Move the pallet truck to a flat surface and try again.

This publication, or portions thereof, may not be duplicated without written permission from the Manufacturer. All information contained in this manual is based on the data available at the time of its publication; the Manufacturer reserves the right to make changes to its products at any time without notice and without incurring any penalty. We therefore recommend that you always check for any updates.

The individual in charge of pallet truck operation must ensure that all safety regulations in force in the country of use are applied, ensuring that the appliance is used in accordance with the purpose it is intended for and to avoid any danger for the user.

The Manufacturer declines any liability arising from any weighing operation errors.



# EU DECLARATION OF CONFORMITY

EU-KONFORMITÄTSERKLÄRUNG  
DÉCLARATION UE DE CONFORMITÉ

Rice Lake Weighing Systems  
230 West Coleman Street  
Rice Lake, Wisconsin 54868  
United States of America



Type/Typ/Type: RL-HPJ

English We declare under our sole responsibility that the products to which this declaration refers to, is in conformity with the following standard(s) or other regulations document(s).

Deutsch Wir erklären unter unserer alleinigen Verantwortung, dass die Produkte auf die sich diese Erklärung bezieht, den folgenden Normen und Regulierungsbestimmungen entsprechen.

Francais Nous déclarons sous notre responsabilité que les produits auxquels se rapporte la présente déclaration, sont conformes à la/aux norme/s suivante ou au/aux document/s normatif/s suivant/s.

EU Directive	Certificates	Standards Used / Notified Body Involvement
2014/30/EU EMC	-	EN 61000-6-2:2015, EN 61000-6-4:2007+A1:2011, EN61326-1:2013, EN55011:2009 +A1:2010
2014/35/EU LVD	-	EN 61010-1:2010
2011/65/EU RoHS	-	EN 50581:2012
2006/42/EU Machinery	-	EN 13155:2009

Devices marked with the legal metrology marking: / Geräte, die mit der gesetzlichen Messtechnik gekennzeichnet sind: / Appareils marqués du marquage métrologique légale:

2014/31/EU NAWI	0200-NAWI-07104	EN 45501 Notified Body involved with module B and D: / Benannte Stelle, die an Modul B und D beteiligt ist: / Organisme notifié impliqué dans les modules B et D: Module B: Force Certification - 0200 Module D: NMI Certin B.V. - 0122
-----------------	-----------------	--

Signature: Richard Shipman

Place: Rice Lake, WI USA

Type Name: Richard Shipman

Date: August 27, 2019

Title: Quality Manager



© Rice Lake Weighing Systems Europe B.V. Specifications subject to change without notice.  
Rice Lake Weighing Systems is an ISO 9001 registered company.

NL-6666 MH Heteran • Netherlands  
TEL: +31 (0)26 472 1319 • FAX: +31 (0)88 234 9100