

Ishida WM-Micro

Tabletop Wrapper
3rd Edition

Service Manual

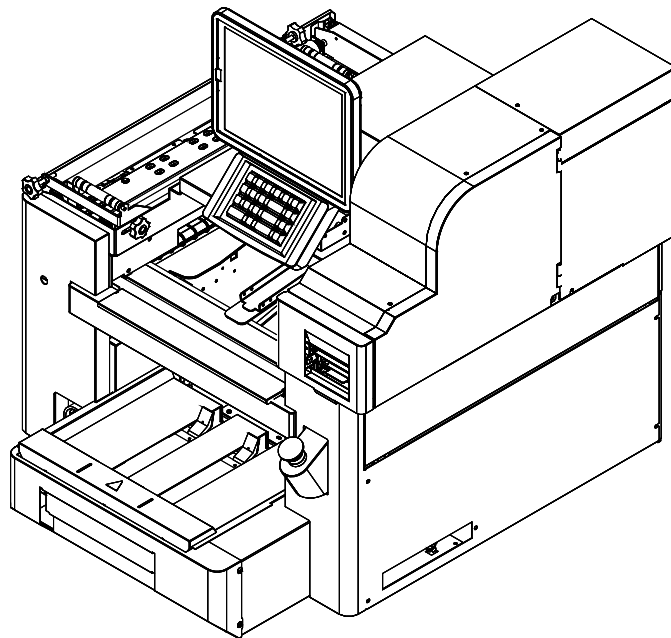

IMPORTANT

- When this machine is not in use for reasons such as decommissioning or moving, unplug the power supply so as not to energize this machine.
- Be especially careful with the orange wiring section, as it is always energized. Before removing the cover of this machine for maintenance or other reasons, be sure to disconnect the power supply by unplugging the power supply.

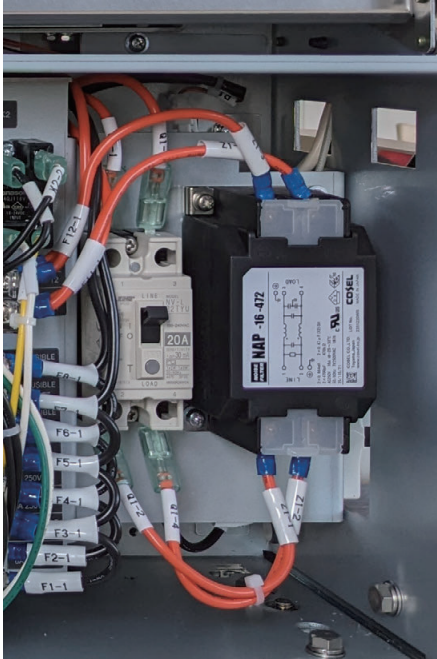

© ISHIDA Co., Ltd. 2024 All rights are reserved.

No part of this publication may be reproduced, stored in a retrieval system, or transmitted in any form or by any means mechanical, electronic, photocopying, recording, or otherwise without prior written permission of ISHIDA.

Revsion History



Version	Date	Discription
1	May 2024	1st edition
2	September 2024	Throughout modifications were made.
3	October 2024	Updated Chapter 5

Introduction



- This service manual contains information necessary for servicing the machine.
- Do not carry out installation, operation, service, or maintenance until thoroughly understanding the contents of this manual.
- These service instructions are for use by qualified service personnel who fully understand the potential hazards involved. To avoid any possible danger, do not perform any service procedures unless qualified to do so. To ensure personal safety, do not perform any service procedures that are not specifically mentioned in this manual.
- Names of parts in this manual use functional expressions. Therefore, they might be different from names of parts in the parts list.
- Signal Words

This machine is manufactured for use according to proper procedures by a qualified person and only for the purposes described in this manual. The following conventions are used to indicate and classify precautions depending on the level of danger, or seriousness of potential injury. Always heed the information provided in this manual and the stickers put on the machine. Failure to heed precautions may result in personal injury or property damage.

1. Precautions

Signal Word	Meaning
 DANGER!	Indicates a potentially hazardous situation, which, if not avoided, will result in severe injury or death.
 WARNING	Indicates a potentially hazardous situation, which, if not avoided, could result in severe injury or death.
 CAUTION	Indicates a potentially hazardous situation, which, if not avoided, may result in minor or moderate injury or in property damage.

2. Information

Signal Word	Meaning
NOTE:	Indicates information that needs to be noted or emphasized.
 INFORMATION	Indicates the reference information.
 REFERENCE	Indicates the reference page.

 WARNING	<ul style="list-style-type: none"> • Make sure to shut off the power supply before performing maintenance. • Make sure to confirm the correct behavior of the machine, the electromagnetic contactors, the safety switches, and the emergency switches after performing maintenance.
--	--

Table of Contents

Introduction	4
Chapter 1 Overview	1-1
1.1 Specifications	1-1
1.1.1 General Specifications	1-1
1.1.2 Wrapping Unit Specifications	1-2
1.1.3 Weighing Unit Specifications	1-2
1.1.4 Operation Unit Specifications	1-3
1.1.5 Printer Unit Specifications	1-3
1.1.6 Software Specifications	1-4
1.1.7 Options	1-4
1.1.8 Reliability / Product Life / Standard	1-4
1.2 Part Name	1-5
1.2.1 Appearance	1-5
1.2.2 Accessory	1-6
1.3 Outline Dimensional Drawings	1-7
1.3.1 Dimensions	1-7
1.4 Installation Space	1-11
1.5 Power Supply	1-11
1.6 Instruction for Carrying and Setting	1-12
1.6.1 Carrying the Machine	1-12
1.6.2 Setting on the Stand or the Table	1-13
1.6.3 Raising Operation and Touch Panels	1-14
1.6.4 Setting a Film	1-15
Chapter 2 Setup Mode	2-1
2.1 Setup Mode	2-1
2.1.1 Startup	2-1
2.2 Machine No. Settings	2-3
2.2.1 MACHINE No. (BASIC)	2-3
2.2.2 MACHINE No. (IP ADDR.)	2-4
2.2.3 MACHINE No. (PC COM)	2-5
2.2.4 MACHINE No. (WiFi)	2-6
2.2.5 MACHINE No. (GLOBAL SV.)	2-7
2.2.6 MACHINE No. (SYNC.)	2-8
2.2.7 MACHINE No. (OUTSIDE PRINTER)	2-9
2.3 Password (Operate)	2-10
2.4 Key Locks	2-12
2.4.1 KEY LOCK (DISPLAY KEY)	2-12
2.4.2 KEY LOCK (FUNCTION KEY)	2-13
2.4.3 KEY LOCK (STROKE KEY)	2-14

2.5	Data Storage.....	2-15
2.5.1	DATA STORAGE (TOTAL ADD.).....	2-15
2.5.2	DATA STORAGE (TOTAL PROC.).....	2-16
2.5.3	DATA STORAGE (TRANSACTION).....	2-17
2.5.4	DATA STORAGE (STORAGE).....	2-18
2.6	PLU Overwrite.....	2-19
2.7	PLU Initial Data	2-20
2.7.1	PLU INITIAL DATA (SALE1).....	2-20
2.7.2	PLU INITIAL DATA (MSG.).....	2-21
2.7.3	PLU INITIAL DATA (IMAGE).....	2-22
2.7.4	PLU INITIAL DATA (PRINT).....	2-23
2.7.5	PLU INITIAL DATA (DATE).....	2-24
2.7.6	PLU INITIAL DATA (CODE).....	2-25
2.7.7	PLU INITIAL DATA (WRAP).....	2-26
2.7.8	PLU INITIAL DATA (SCHEME).....	2-27
2.7.9	PLU INITIAL DATA (TARGET).....	2-28
2.8	PLU Update	2-29
2.9	Label Combination.....	2-30
2.9.1	LABEL COMB.....	2-30
2.9.2	LABEL COMB. (BASIC).....	2-31
2.9.3	LABEL COMB. (LABEL).....	2-32
2.9.4	LABEL COMB. (UPPER FIX).....	2-34
2.9.5	LABEL COMB. / DETAIL.....	2-35
2.10	Label Format	2-36
2.10.1	LABEL FORMAT.....	2-36
2.10.2	LABEL FORMAT / PRINT CONTROL.....	2-37
2.10.3	LABEL FORMAT / DETAIL (BASIC).....	2-38
2.10.4	LABEL FORMAT / DETAIL (UNIT).....	2-40
2.10.5	LABEL FORMAT / DETAIL (PREVIEW).....	2-41
2.10.6	LABEL FORMAT / DETAIL (LABEL).....	2-42
2.11	Barcodes	2-43
2.11.1	BARCODE (POS FLAG).....	2-43
2.11.2	BARCODE (POS CODE).....	2-44
2.11.3	BARCODE (ITEM CODE).....	2-45
2.12	Custom Barcodes.....	2-46
2.12.1	CUSTOM BARCODE.....	2-46
2.12.2	CUSTOM BARCODE (BASIC).....	2-47
2.12.3	CUSTOM BARCODE (PREVIEW).....	2-48
2.13	Menu Title (Operate).....	2-49
2.14	Operation Settings.....	2-50
2.14.1	OPERATION SETTING (CALL1).....	2-50
2.14.2	OPERATION SETTING (CALL2).....	2-51

2.14.3	OPERATION SETTING (PROD.)	2-52
2.14.4	OPERATION SETTING (PRINT.)	2-54
2.15	Error Processes	2-55
2.15.1	ERROR PROCESS (ISSUE)	2-55
2.15.2	ERROR PROCESS (CALL)	2-56
2.15.3	ERROR PROCESS (COMMON)	2-57
2.16	Error Log (Display)	2-58
2.17	Trace	2-59
2.18	Dual Currency	2-60
2.19	Price Rounding	2-61
2.20	Frequent Shopper	2-62
2.21	Standby Mode	2-63
2.22	Country	2-64
2.22.1	COUNTRY	2-64
2.22.2	Country / Detail (Currency)	2-65
2.22.3	Country / Detail (Weight)	2-66
2.22.4	COUNTRY / DETAIL (DATE)	2-67
2.23	File Save / Load	2-68
2.23.1	FILE SAVE / LOAD (USB>SCALE)	2-68
2.23.1.1	FILE SAVE / LOAD / INPUT SELECT	2-69
2.23.2	FILE SAVE / LOAD (SCALE>USB)	2-70
2.23.2.1	FILE SAVE / LOAD / OUTPUT SELECT	2-71
2.23.3.1	FILE SAVE / LOAD / DELETE SELECT	2-73
2.23.4	FILE SAVE / LOAD (SCALE INIT.)	2-74
2.23.5	FILE SAVE / LOAD / DETAIL	2-75
Chapter 3	Adjustment Mode	3-1
3.1	Adjustment Mode	3-1
3.1.1	Startup	3-1
3.2	Date Time	3-3
3.3	Touch Screen	3-5
3.4	Display Check	3-6
3.5	Sound	3-7
3.6	Key Check	3-8
3.7	Firmware Details	3-9
3.8	Memory Clear	3-10
3.9	Printer (Label equipped)	3-12
3.9.1	PRINTER (HEAD)	3-12
3.9.2	PRINTER (PEEL SENSOR)	3-14
3.9.3	PRINTER (LABEL TYPE)	3-15
3.9.4	PRINTER (LABEL FEED)	3-16

3.10	Printer (Linerless)	3-18
3.10.1	PRINTER (HEAD)	3-18
3.10.2	PRINTER (PEEL SENSOR)	3-20
3.10.3	PRINTER (LABEL TYPE)	3-21
3.10.4	PRINTER (LABEL FEED)	3-22
3.10.5	PRINTER (LINERLESS)	3-23
3.10.6	PRINTER(PRN. ROLLER)	3-24
3.11	Calibration	3-25
3.11.1	Procedure for adjusting scale (span)	3-26
3.12	Machine Type	3-27
3.12.1	MACHINE TYPE	3-27
3.12.2	MACHINE TYPE / DETAIL	3-28
3.12.3	MACHINE TYPE / PRINTER	3-29
3.13	Download	3-30
3.13.1	DOWNLOAD (MAIN)	3-30
3.13.2	DOWNLOAD (SUB APP.)	3-31
3.13.3	DOWNLOAD (SUB BOOT)	3-32
3.14	Option Checks	3-33
3.14.1	OPTION CHECK (SCANNER)	3-33
3.14.2	OPTION CHECK (USB)	3-34
3.14.3	OPTION CHECK (DEVICE)	3-35
3.15	Wrappng Machine	3-36
3.15.1	WRAPPNG MACHINE (FILM)	3-36
3.15.2	WRAPPNG MACHINE (INITIAL)	3-37
3.15.3	WRAPPNG MACHINE (TABLETOP)	3-38
3.16	Unit Action	3-39
3.16.1	UNIT ACTION (WRAP)	3-39
3.17	Display Capture	3-40
3.18	Gravity	3-41
Chapter 4	Function for Each Mode	4-1
4.1	Nomal Mode	4-2
4.1.1	Return Process at Power ON	4-2
4.1.2	How to Use Preset Keys	4-3
4.2	PROGRAM Mode	4-8
4.2.1	WRAP Tab Added to PLU	4-8
4.2.2	Preset Keys Added	4-10
4.2.3	TRAY Added to Menu	4-11
4.3	SETUP Mode	4-14
4.3.1	Switching to Service Mode	4-14
4.3.2	FUNCTION KEY Items Added to KEY LOCK	4-14
4.3.3	Items Added to PLU OVERWRITE	4-16

4.3.4	WRAP Tab Added to PLU INITIAL DATA	4-17
4.3.5	Items Added to PLU UPDATE	4-18
4.3.6	COUNTRY (MISC) Screen Added.....	4-19
4.3.7	Tray Master Added to FILE SAVE / LOAD.....	4-21
4.4	ADJUST Mode.....	4-23
4.4.1	Switching to Service Mode	4-23
4.4.2	MEMORY CLEAR Items Added.....	4-23
4.4.3	SUB Tab Added to DOWN LOAD.....	4-24
4.4.4	WRAPPING MACHIN Added to Menu	4-26
4.4.5	UNIT ACTION Added to Menu	4-28
4.4.6	MACHINE TYPE Added to Menu.....	4-29
4.4.7	Main board replacement.....	4-30
Chapter 5	Hardware (Mechanical).....	5-1
5.1	Removing Units	5-1
5.1.1	Removing the Infeed Unit.....	5-1
5.1.2	Removing the Printer Unit.....	5-5
5.1.3	Removing the Operation Unit.....	5-8
5.1.4	Removing the Wrapping Unit.....	5-9
5.1.5	Dividing the Film Conveying Unit into Two	5-14
5.1.6	Point for Unit Assembly.....	5-26
5.2	Adjustment.....	5-27
5.2.1	Adjusting Lift Height.....	5-27
5.2.2	Adjusting the Film Arm.....	5-30
5.2.3	Adjusting the Operating Range of the Infeed Unit's Claw.....	5-41
5.2.4	Adjusting Cutter Solenoid Position	5-43
5.2.5	Adjusting Cutter Blade Position	5-44
5.2.6	Adjusting Left and Right Squeezing Plates Widening Amount	5-45
5.2.7	Adjusting Squeeze Amount of the Rearqueezing Plate	5-46
5.2.8	Adjusting Discharge Pusher Standby Position	5-47
5.2.9	Adjusting Tray Holder Height.....	5-48
5.2.10	Adjusting Claw Height of the Infeed Unit	5-49
5.3	Parts Replacement	5-50
5.3.1	Print Roller (Linerless)	5-50
5.3.2	Print Roller (with liner)	5-53
5.3.2	Timing Belt.....	5-55
5.3.3	Cutter Unit.....	5-62
5.4	Adjustment.....	5-66
5.4.1	Cutter Unit	5-66
5.4.2	Label guide of the turn roller	5-71
5.4.3	Position of label roll guide	5-72

5.5	Periodic replacement / consumable parts	5-73
5.5.1	Label equipped printer	5-73
5.5.2	Linerless printer.....	5-73
5.5.3	Wrapping unit	5-74
Chapter 6	Hardware (Electrical)	6-1
6.1	Electrical Unit Board Configuration	6-1
6.1.1	Alignment of PCB.....	6-1
6.1.2	Main board P-1180 (A10).....	6-2
6.1.3	Wrapping control board P-1186 (A1)	6-4
6.1.4	Motor driver board P-1006 (A2)	6-6
6.1.5	Interface board P-1102 (A30).....	6-6
6.1.6	A/D conversion board P-1111 (A40)	6-6
6.1.7	Front side of the machine.....	6-7
6.1.8	Left side of the machine.....	6-8
6.1.9	Back side of the machine.....	6-9
6.1.10	Right side of the machine.....	6-10
6.2	Sensor Location	6-11
Chapter 7	Troubleshooting.....	7-1
7.1	Operation as IP (Scale and Printer)	7-1
7.2	Error Message.....	7-2
7.2.1	Error Display	7-2
7.3	Error List.....	7-3
7.3.1	Error relates to System (Code 100s)	7-3
7.3.2	Error relates to Memory (Code 200s)	7-5
7.3.3	Error relates to Pre-check (Code 300s).....	7-8
7.3.4	Error related to Wrapper (Code 400s to 500s).....	7-12
7.3.5	Error related to Printer (Code 700s).....	7-46
7.3.6	Error related to Scale (Code 1600s)	7-60
Appendix 1	Wrapping by WM-MICRO.....	App-1
1.1	PART NAMES	App-1
1.2	WRAPPING OPERATION	App-2
Appendix 2	Electric Wiring Diagram	App-4
2.1	Page 1.....	App-4
2.2	Page 2	App-5
2.3	Page 3	App-6

Chapter 1 Overview

1.1 Specifications

1.1.1 General Specifications

Item	Details
Model	WM-MICRO
Product category	Push-up type wrapper
Product lineup	<ul style="list-style-type: none"> • MS: Liner-equipped single printer LL type • MS F: Linerless single printer LL type • MS: Liner-equipped single printer L type • MS F: Linerless single printer LL type
Environmental conditions	Temperature: 5 to 35°C (Linerless label: 5 to 30°C) Humidity: 20 to 85%, Non-condensing (Linerless label: 30 to 75%, Non-condensing) Altitude above sea level: Less than 1000 m
Dimensions	MS(LL type): W800 mm D865 mm H850 mm MS F(LL type): W825 mm D740 mm H734 mm MS(L type): W745 mm D865 mm H850 mm MS F(L type): W770 mm D740 mm H734 mm
Exterior	Stainless (partly resin molded)
Power supply	2-phase 200 to 240 VAC, 50/60 Hz No need to change components in accordance with the power supply frequency.
Full-load current	5.4 A
Grounded system	TT, TN
Leakage current	1.6 mA MAX
Packs per minute	15 packs per minute (max.)
Weight for wrapping capacity	40 to 3500 g
Weight for weighing capacity	40 to 15000 g
Machine weight	Less than 130 kg Less than 108 kg (without operation unit and printer unit)
Noise	Less than 75 dB (dry run) Less than 73 dB (packing)
Current consumption	Less than 6 A (running) Less than 1 A (sleep)

1.1.2 Wrapping Unit Specifications

Item	Details
Wrapping method	Push-up wrapping method
Wrapping size	Width: 150 to 380 mm (LL type) 150 to 350 mm (L type) Depth: 127 to 244 mm Height: 10 to 130 mm Wrapping may not be available depending on the combination. Tray height: Less than 45 mm Minimum tray bottom dimensions: Width 120 mm, Depth 80 mm Wrapping depth of the genuine film (Less than 500mm wide): Less than 230 mm Maximum depth when using 560 mm wide film. LL type can wrap with 25SH (380x210x30) film when the height is 80 mm or less at the center of the tray and 70 mm or less at the edge of the tray. Wrapping with 10x14 inch (360x254x30) is not possible.
Tray material	PSP, PP, PET
Tray shape	Rectangle A tray with legs, soft tray, and non-rectangular tray cannot be used.
Film size	Possible film installation width: 400, 450, 500 mm Installation possible up to 560 mm
Outside diameter of the film	Installation possible up to 200 mm
Film type	Polyolefin, polyvinyl chloride (for winding machine)
Recommended film	A50: 400, 450, 500 mm Ishida Wrap Super: 400, 450, 500 mm A50 may have specification limitations in hot and humid environments.
Infeed carrier method	Carrying claw method (fixed speed)
Film replacement	Set on rollers, outer diameter supporting Replace from the side of the machine (without auto-loading).
Film welding	Rollers with cartridge heater Do not leave tray on the heater. When the sealing is weak, press it against the roller again.
Cleaning	Lift head is detachable (washable) Platter is detachable (washable) Garbage tray is detachable (washable) Film roll cover (option)

1.1.3 Weighing Unit Specifications

Item	Details
Scale weight	15000 g 0 g or more and less than 6000 g - scale interval of 2 g, 6000 g or more and up to 15000 g – scale interval of 5 g (multi-interval) 30 lb multi 0 lb or more and less than 15 lb – scale interval of 0.005 lb, 15 lb or more and up to 30 lb – scale interval of 0.01 lb (multi-interval) 30 lb single-range 0 lb or more and less than 30 lb – scale interval of 0.01 lb,
Weighing accuracy	1/3000 (Precision class based on new measurement standards in Japan: Class III)

1.1.4 Operation Unit Specifications

Item	Details
Display	12.1 inch TFT color SVGA LCD (800 x 600)
Input unit	Analog touch panel of thin film resistive system Stroke keys (up to 24 keys)
Standard input/output	10/100BASE-TX LAN: 1 channel USB: 4 channels
Main board	P-1180
OS	Linux
Sheet of operation unit	Application of Ishida Retail Unified Design Deleted model names and notation related to the Measurement Law
Memory	1 GB (PLU master: 30000 items)

1.1.5 Printer Unit Specifications

Item	Details
Printing method	Direct thermal method
Printing speed	120 mm/sec
Label size	Liner-equipped printer Width: 33 to 80 mm Top / Bottom: 23 to 105mm Linerless printer Width: 44, 60, 80 mm Top / Bottom: 30 to 500mm Assistance is required for 105 mm or more.
Maximum print width	Liner-equipped printer: Width 76 mm Linerless printer: Width 77mm
Thermal head	3 inch (960 dots), 12 dots/mm thermal head
Diameter of label roll	Internal diameter of paper tube: 40 mm Maximum outer diameter: 125 mm Common specification for liner-equipped and linerless.
No. of storage label	Liner-equipped: 1820 labels (Top / Bottom 37 mm, label pitch 2.5 mm) Linerless: Roll length 100 m (about 2700 labels with top / bottom 37 mm)
Recommended label	Liner-equipped: Osaka sealing V8NS Linerless: Ricoh Ishida specific label
Printing accuracy	Liner-equipped printer: Write position: ± 1 mm Width direction: ± 1 mm Print length: ± 1 mm (top / bottom 60 mm), ± 1.5 mm (top / bottom more than 60 mm) Linerless printer: Write position: ± 1 mm Width direction: ± 2 mm Print length: Shrinkage is within 8% of the set value

1.1.6 Software Specifications

Item	Details
Software specifications	Standard specifications
Communication with higher level devices	SLP supported
Remote maintenance	Machine settings can be checked and changed from the PC
Supprt for linerless label	Enables printing on linerless labels
Remote OS updating	Enables remote OS security updates
Communication availability item settings	Enable/disable communication with upper level for each item in the PLU master
Operation support	Label preview function
Label replacement support	label master switching function
80 mm width label support	Supports a maximum width of 80 mm
Printing ratio	1:1
Barcode	JAN, CODE128, EAN128, UPC, ITF, QR, DataMatrix QR, DataMatrix: Grade is not covered by warranty.
Locale support	Software design for North America and Europe

1.1.7 Options

Item	Details
Options	Stroke key cover Static-eliminating wire Wireless LAN unit Film roll cover unit Infeed pusher Recommended Products USB memory: Hagiwara 1GB UDG4-1GDRJS (000-149-5390-07) USB scanner: Zebra Technologies LS2208-SR20001R

1.1.8 Reliability / Product Life / Standard

Item	Details
Product life	5 years for use (consumable parts excluded) Condition: 1000 packing/day, 350 operating days (4200 hours) 1.75 million packing in 5 years
Standards	Conforming to Ishida product standards Conforming to overseas standards <North America> ETL certified <Europe> CE marking compliant

1.2 Part Name

1.2.1 Appearance

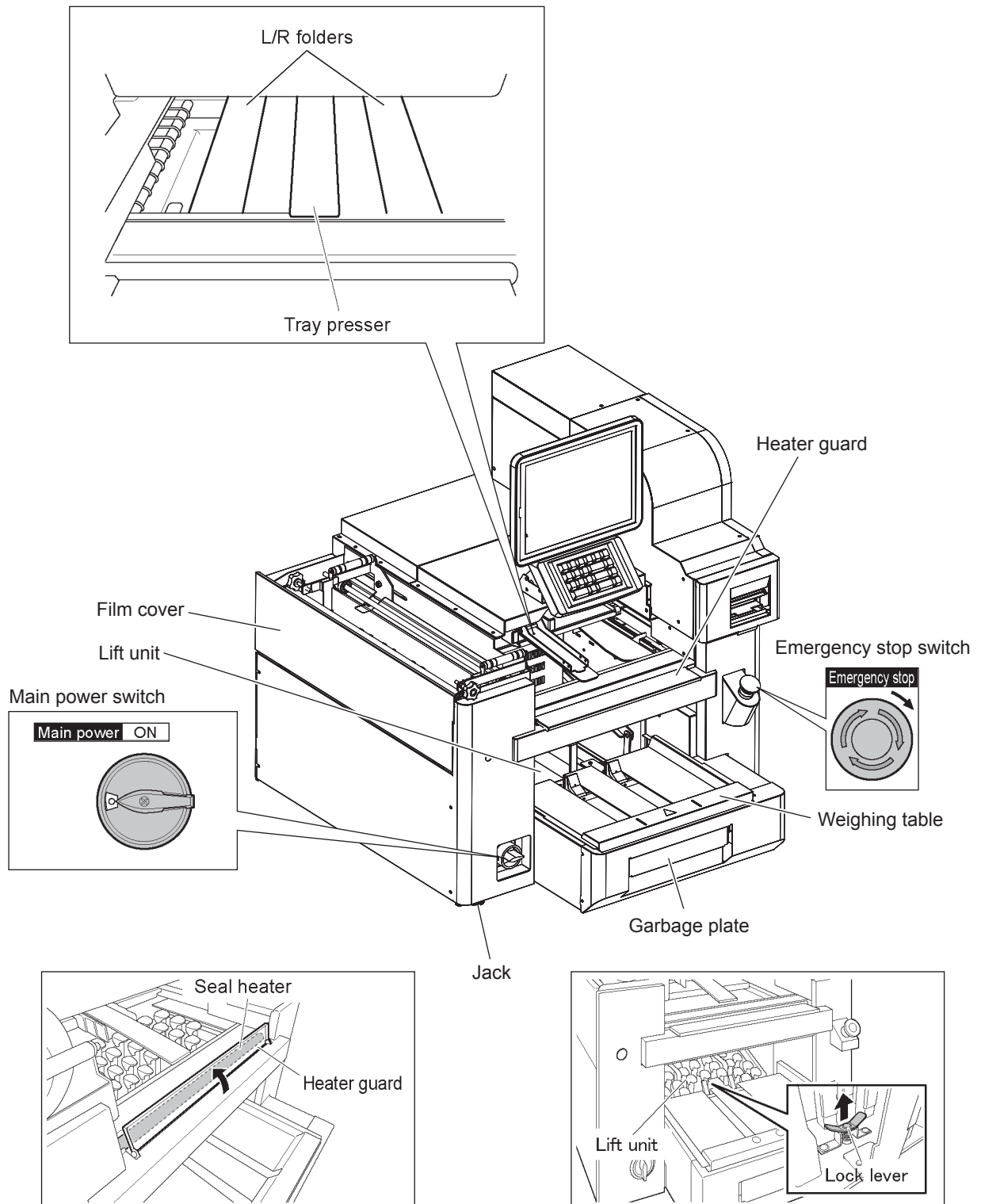

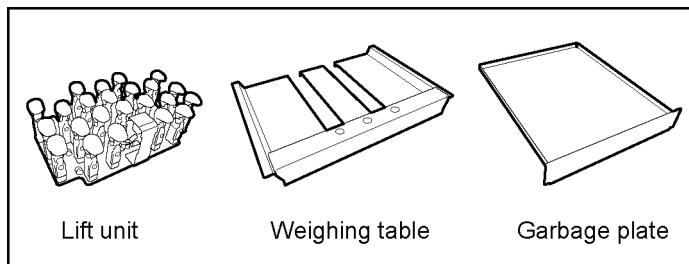
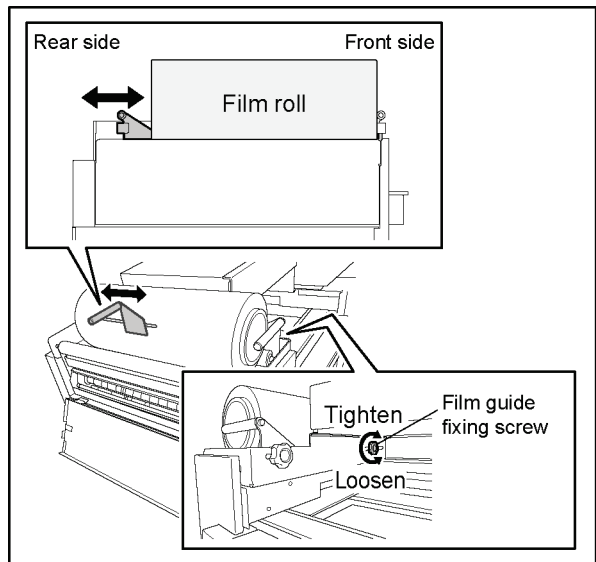
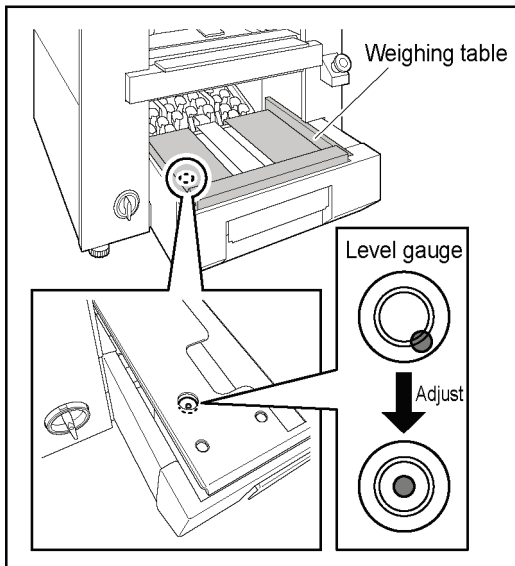

1.2.2 Accessory

DRIVER:HEX:T TYPE

Use for removing tangled film on film feeding roller.

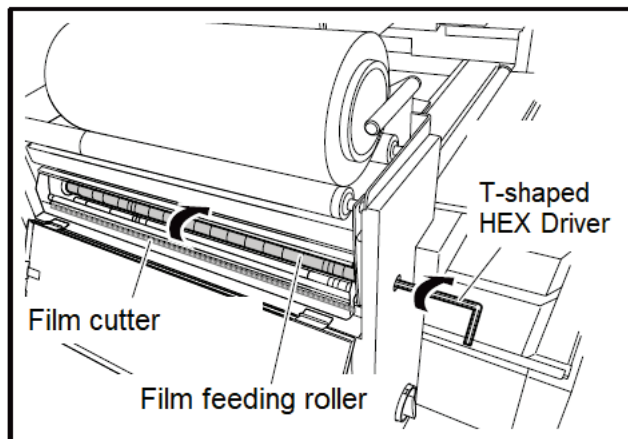

1.3 Outline Dimensional Drawings

1.3.1 Dimensions

Dimensions are shown below.

Provide enough space for carry-in route, setup and maintenance.

WM-MICRO'MS'US (LL type)

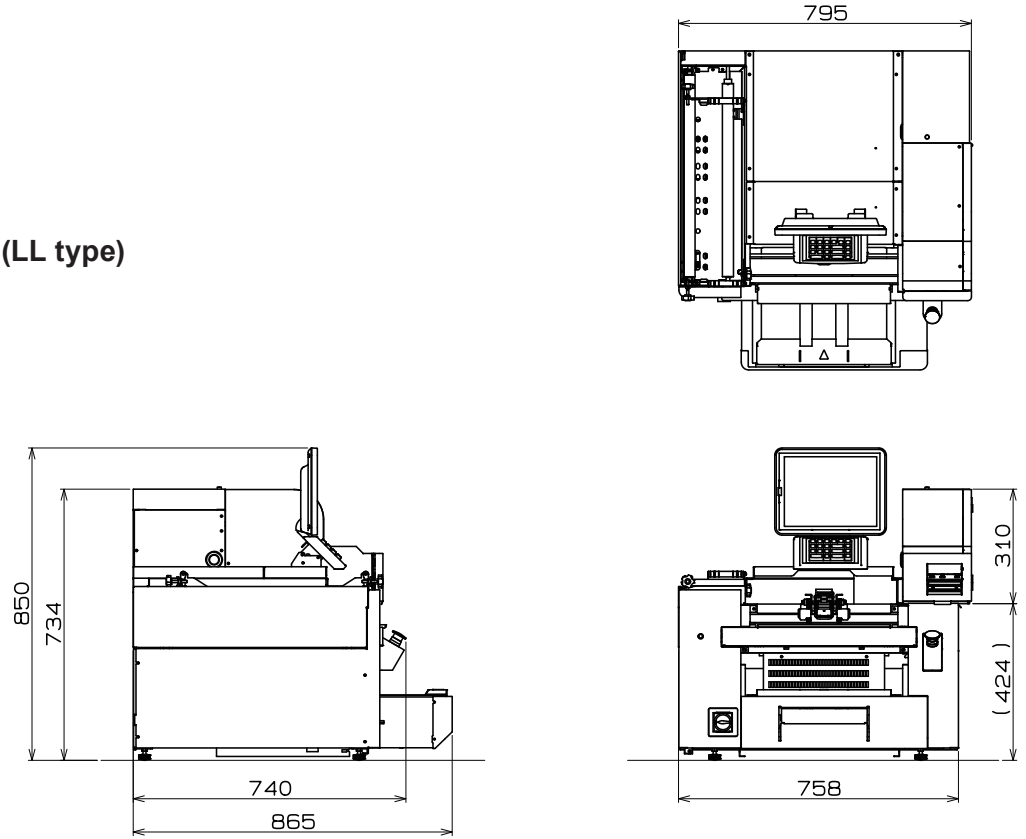

WM-MICRO'MSF'US (LL type)

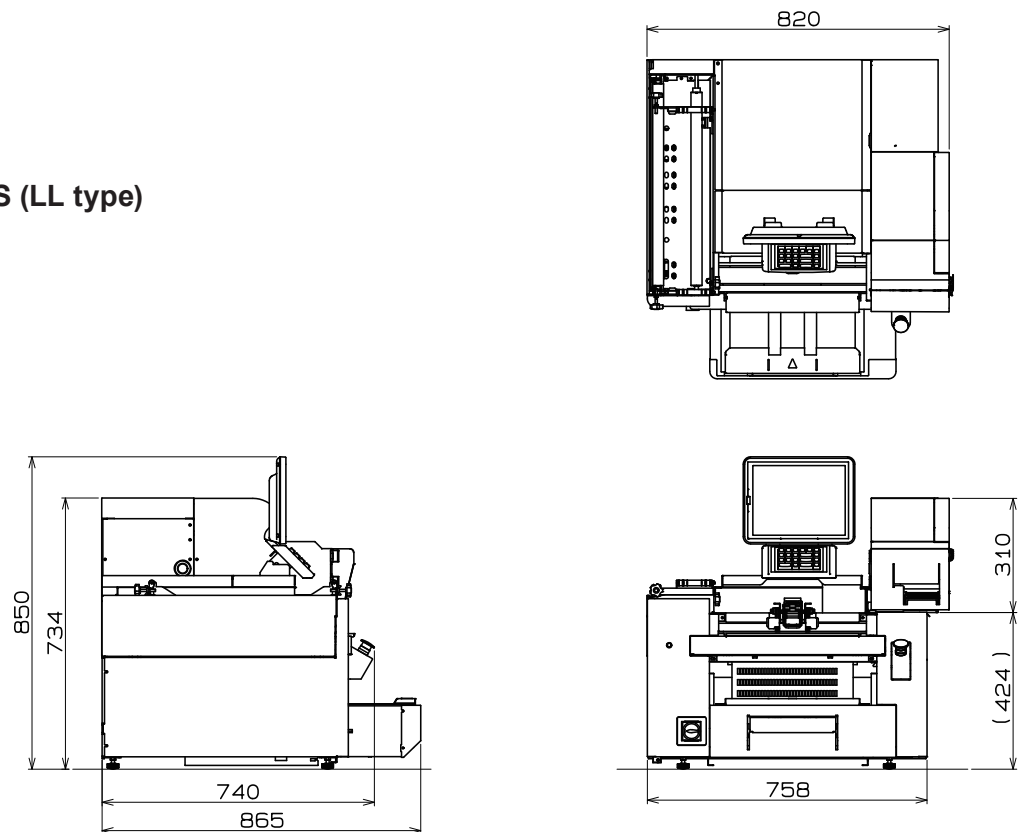

WM-MICRO'MS'EU (L type)

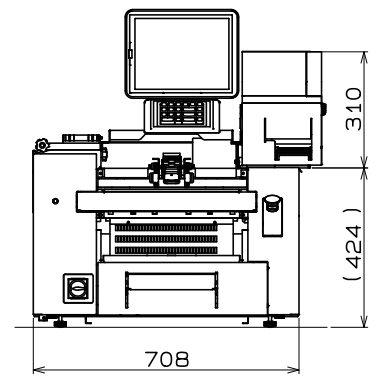
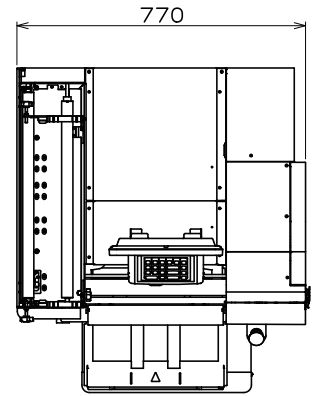
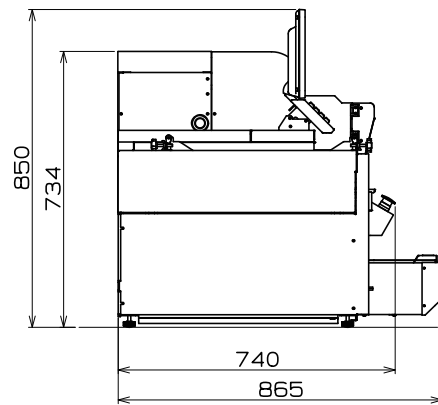

WM-MICRO'MSF'EU (L type)

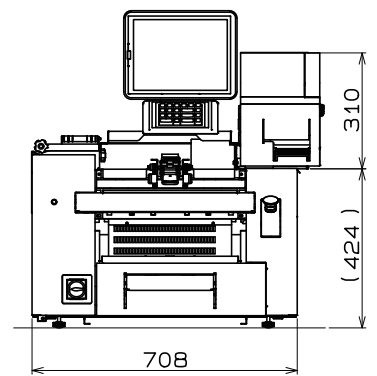
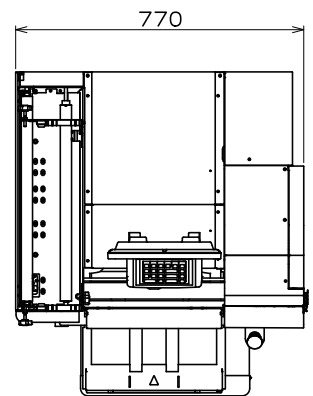
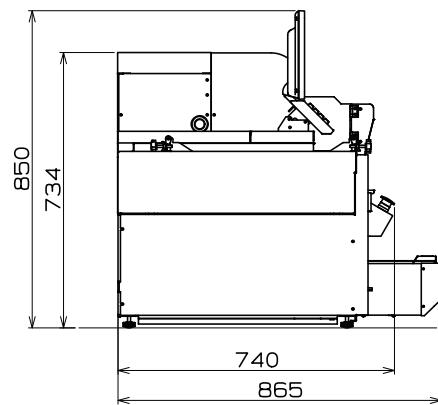

**WM-MICRO'MS'US (LL type)
Packing**

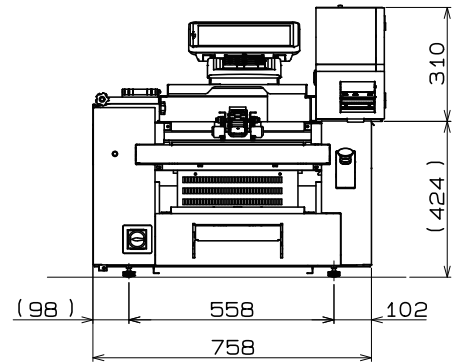
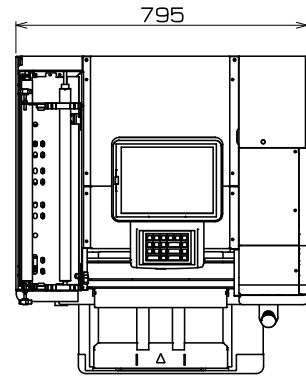
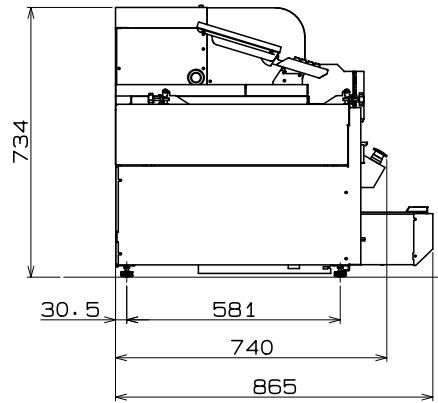

**WM-MICRO'MS'EU (L type)
Packing**

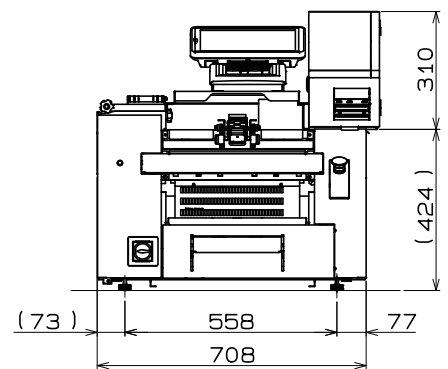
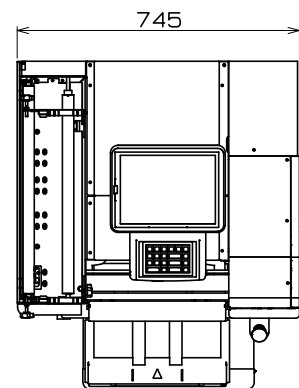
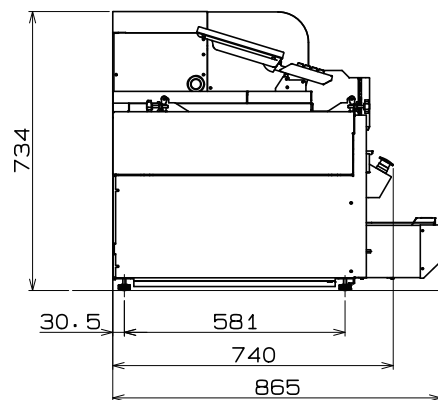

**WM-MICRO'MSF'US (LL type)
Packing**

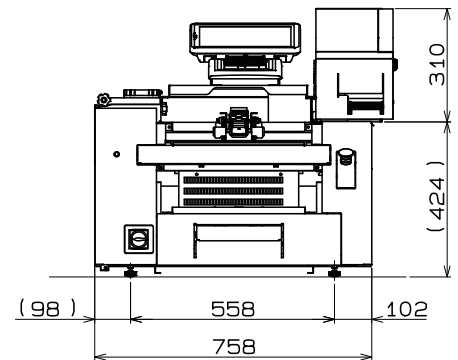
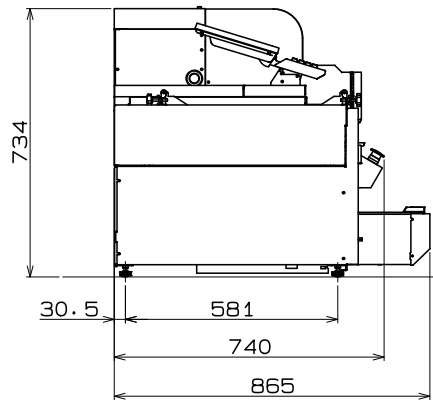
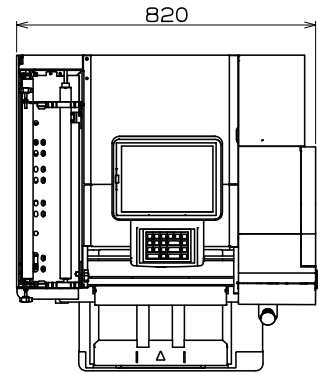

**WM-MICRO'MSF'EU (L type)
Packing**

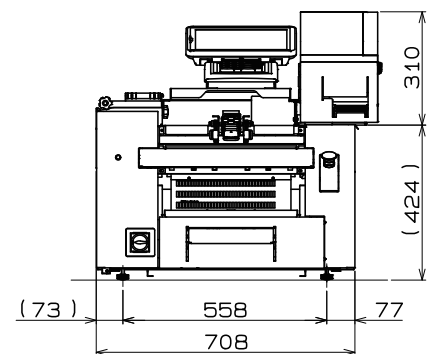
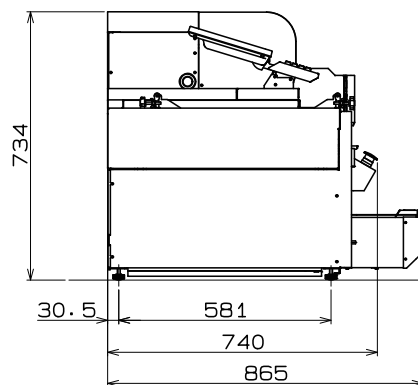
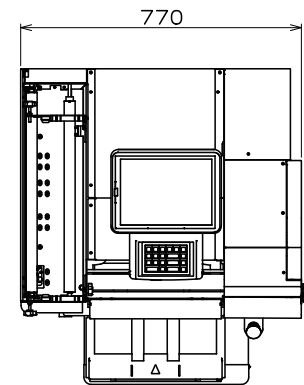

1.4 Installation Space

- Provide enough working space for both sides of the machine.

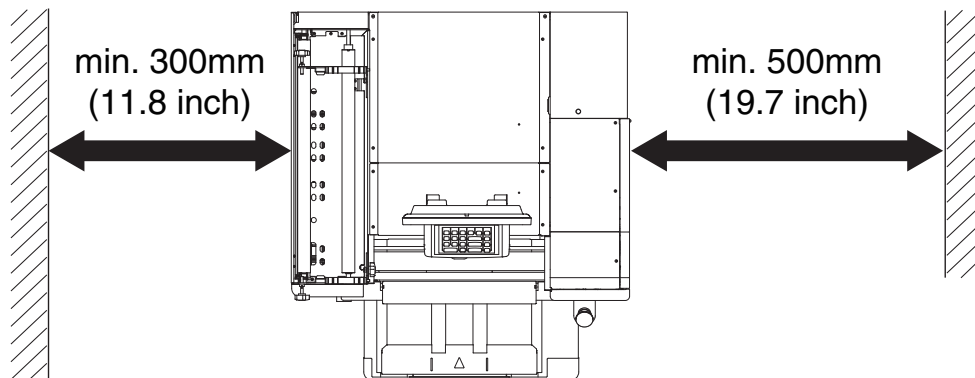

[LL type]	Liner equipped: W795 x D865 mm
	Linerless: W820 x D865 mm
[L type]	Liner equipped: W745 x D865 mm
	Linerless: W770 x D865 mm

1.5 Power Supply



WARNING

HEED THE FOLLOWING PRECAUTIONS ABOUT POWER SUPPLY:

- Use a power supply with rated voltage ground. Prepare a dedicated power source.
- A power supply that generates voltage variation may cause a malfunction.
- Do not stand on the power cord, and do not place anything heavy on the cord.
Doing so may damage the cord, resulting in accident or trouble.

- Power cord
Power cord is not supplied with the machine.
Prepare a power cord that satisfies the rating below.
 - Wire rod AWG#14 or thicker (Equivalent to VCT)
 - Single phase earth
 - Rated voltage 600V or more
 - Cord OD $\phi 11-13.5\text{mm}$
 - Crimping terminal dimensions (refer to fig.1)
 - Tightning torque 1.0 to 1.3 N•m
- Power plug (When required)
 - Rated voltage 250V or more
 - Rated current 20A or more

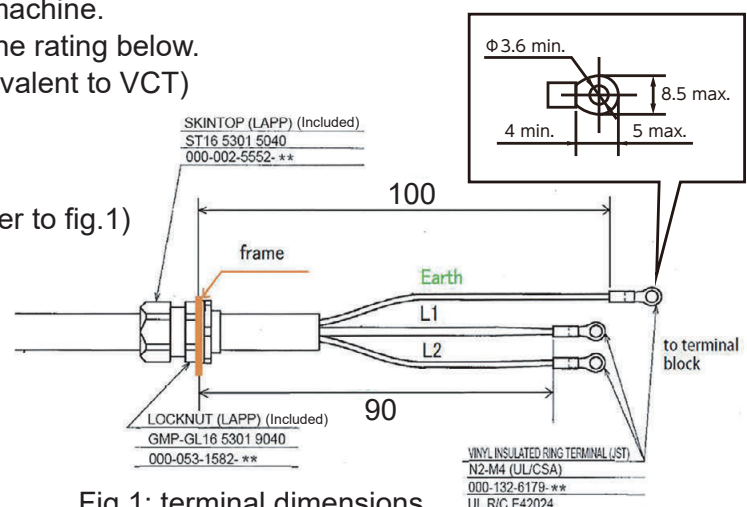

Fig.1: terminal dimensions

1.6 Instruction for Carrying and Setting

- The capacity for the stand of WM-MICRO should be more than 200 kg(440 lb). Please make sure that customers' stands or tables have same or more durability than the example written in this document before the setup.
- The weight of WM-MICRO itself is approximately 130 kg (287 lb). Please be careful not to get injured by dropping the machine when you carry the machine.
- * While the stand in the pictures below is the older type, instructions for carry and installation are not changed.

1.6.1 Carrying the Machine

When carrying the machine, please hold the part between the truss head screws (below picture) at the back (B), and the bottoms of left & right side (A&C). (red circled part at below picture).



CAUTION The weight of WM-MICRO itself is approximately 130 kg (287 lb). Please be careful not to get injured by dropping the machine when you carry the machine.
DO NOT hold the weighing part. It can damage the scale or cause mis-weighings.



CAUTION Do not use a lift under the product to carry. The product must be carried by hand.

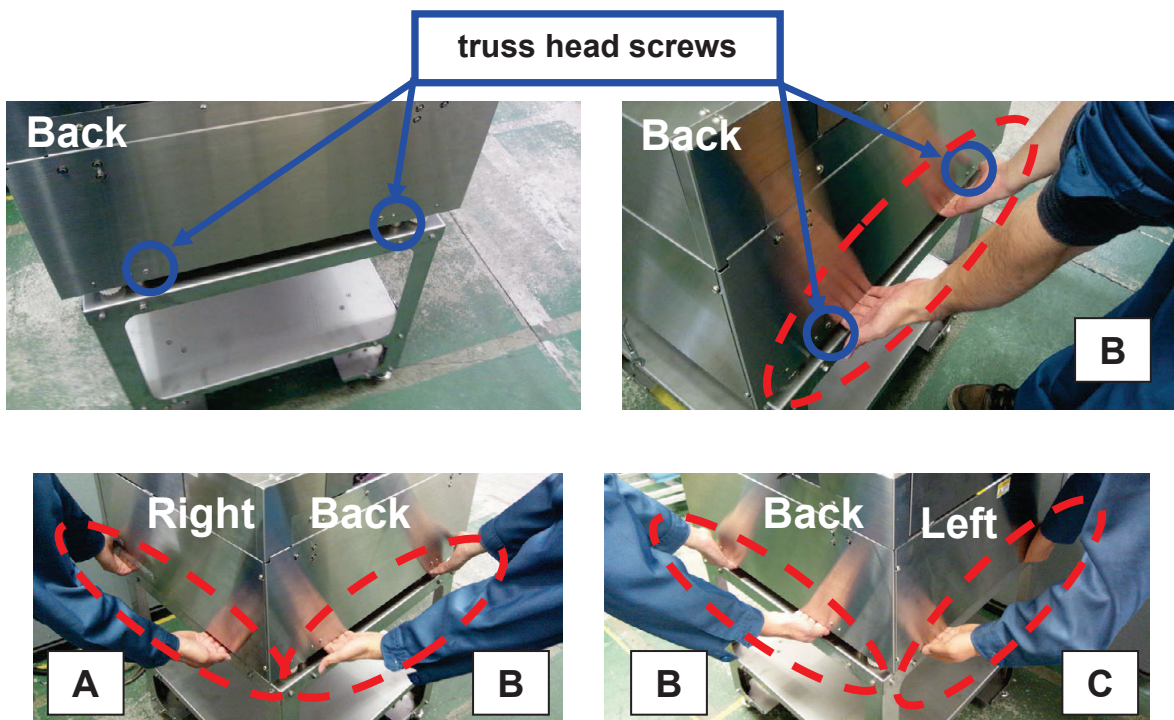

1.6.2 Setting on the Stand or the Table

NOTE: The capacity for the stand of WM-MICRO should be more than 200kg(440lb). Please make sure that customers' stands or tables have same or more durability than the constitution example written below before the setup. Stands for WM-NANO can be converted.



Constitution example

Material of each part:

A : SUS board thickness 2mm (0.08") Boxed type shape

B : SUS board thickness 2mm (0.08") L shape

C : SUS board thickness 2mm Boxed type shape

D : SUS board thickness 3mm



CAUTION Please be careful not to pinch your hands between the stand or the table and the machine when you put the machine on.

1.6.3 Raising Operation and Touch Panels

To prevent damage, the operation and touch panels are housed flat during transportation. After the installation is complete, pull up the operation and touch panels.

1. Remove the two screws on the left and right that secure the operation panel.



2. Pull up the operation panel to replace the screws with the upper holes.

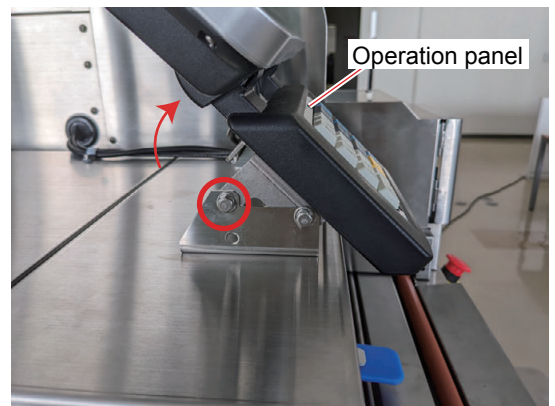

3. Pull up the touch panel.



1.6.4 Setting a Film

Refer to the instruction manual for setting a film.
This section describes important points for setting.

- On the front end, set a film so that the end face of the film should be on the plane of the roller's end face.

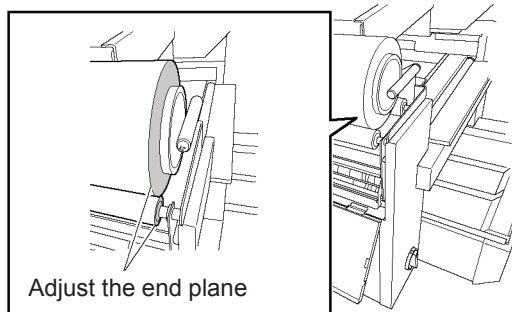

- After adjusting the front end, keep 1 mm gap between the film roll and the film guide surfaces on the back end. Too much force on the film roll by the film guide may interfere with film roll rotation.

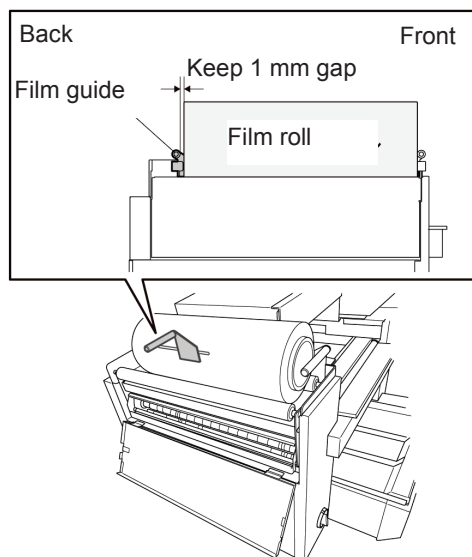

Chapter 2 Setup Mode

2.1 Setup Mode

2.1.1 Startup

1. Turn on the power.

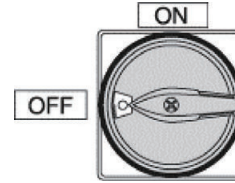

2. The PREPACK screen in the OPERATE mode appears.

Press  at the upper right side of the screen.



3. The menu appears in the OPERATE MODE.

Press the [SET UP] button on the screen.

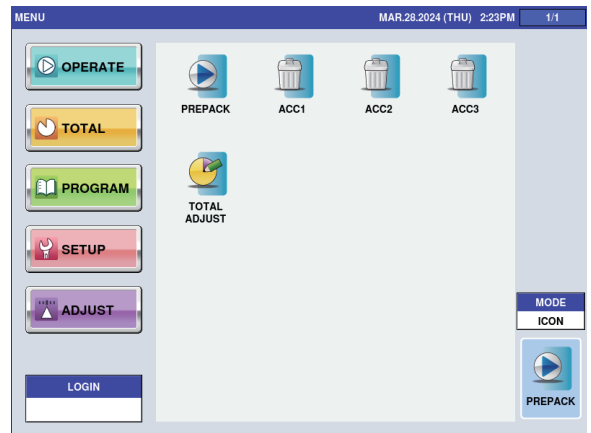

4. The User Menu screen in the Setup mode appears.

Input the password "495344" using the numerical keys, and press the [LOGIN] button on the screen.

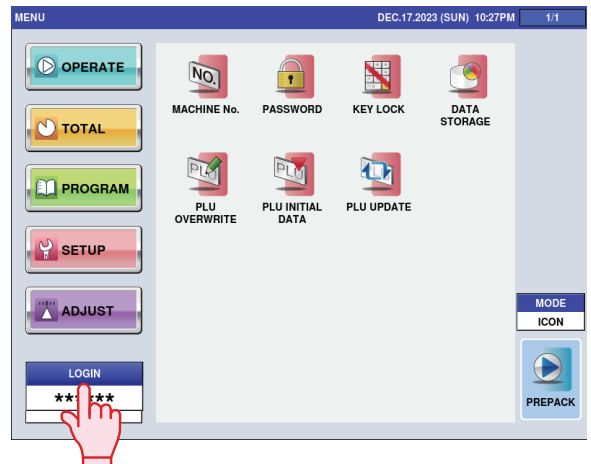

- The User Menu screen in the Setup mode appears.

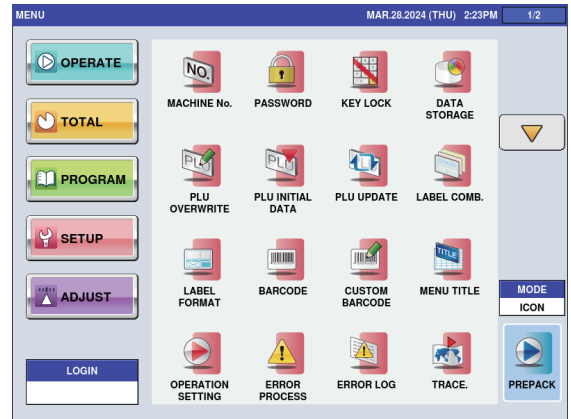

Maintenance Menu screen 1/2

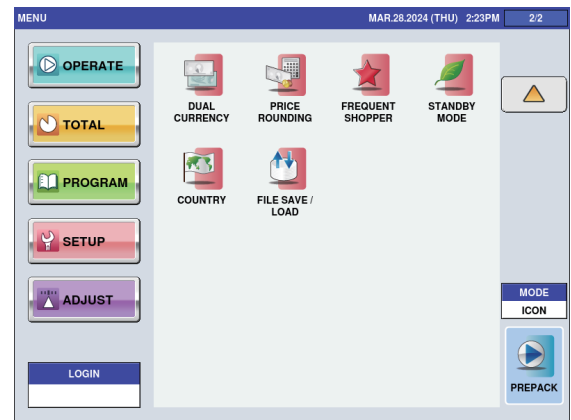

Maintenance Menu screen 2/2

2.2 Machine No. Settings

2.2.1 MACHINE No. (BASIC)

Menu name	Specification
	Return to Menu. Other tabs also have the same function.
NETWORK No.	Set the machine No. Input range: 0 to 9999
MACHINE SET	Select one of the stand-alone, master or satellite machines. ALONE (fixed) This function is enabled only when you log into the service network.

2.2.2 MACHINE No. (IP ADDR.)

Menu name	Specification
IP ADDRESS	Set the IP address. Input range: "0.0.0.0" to "255.255.255.255"
SUBNET MASK	Set the subnet mask. Input range: "0.0.0.0" to "255.255.255.255"
DEFAULT GATEWAY	Set the default gateway. Input range: "0.0.0.0" to "255.255.255.255"
DNS SERVER1	Set the IP address of Primary DNS server. Input range: "0.0.0.0" to "255.255.255.255"
DNS SERVER2	Set the IP address of Secondary DNS server. Input range: "0.0.0.0" to "255.255.255.255"
DHCP MODE	Select whether or not to use DHCP.
PING TO PC	Ping the PC. Other tabs also have the same function.
	Enter "."(dot). Used for IP address vsetting. Other tabs also have the same function.

2.2.3 MACHINE No. (PC COM)

Menu name	Specification
PC IP ADDRESS	Set the PC's IP address. Input range: "0.0.0.0" to "255.255.255.255"
PC PORT No.	Set the PC's port No. Input range: 0 to 65535
COM CHECK PERIOD (SEC)	Set the command check period. Input range: 0 to 9999
COM CHECK TIME OUT (SEC)	Set the command check time-out. Input range: 2 to 5
ERROR LOG SEND	Set whether or not to send the error log.
FIELD NAME ENABLE	Select and set whether or not to add filed name to the CSV title line of the transmission data.
PRESET FUNC. NAME REFER	Select the preset function name reference. COM.DATA / PLU
LAN CONNECT CHECK	Set whether or not to perform LAN connect check.
PROD. TRAN SEND	Set whether or not to perform transmission of Production Transaction. (SLP-5)

2.2.4 MACHINE No. (WiFi)

Menu name	Specification
SECURITY / AUTHENTICATION / ENCRYPTION	Select the method of security/authentication/encryption. NONE / WEP128 / WPA PSK TKIP / WPA2 PSK CCMP
SSID (WIRELESS NETWORK NAME)	Set the SSID. Pressing the button opens the Editor screen to edit.
KEY TYPE	Select the WEP key index. HEX / ASCII / PASSPH
WEP KEY INDEX	Select the WEP key index. 1 / 2 / 3 / 4 This function is enabled only when one of WEP64 / WEP128 / is selected for security / authentication / encryption.
WEP64 KEY	Set the WEP64 Key. Up to 5 bytes This function is enabled only when one of WEP128 / WEP64 Shared Key / WEP128ShKey is selected for security / authentication / encryption.

2.2.5 MACHINE No. (GLOBAL SV.)

MACHINE No. (GLOBAL SV.) MAR.28.2024 (THU) 2:24PM

GLOBAL SERVICE URL
http://i-globalservice.appspot.com

PROXY SERVER URL

REMOTE OPERATION

DISABLE ENABLE VNC ENABLE VNC+SSH

SSH PORT
49534

PING TO SERVICE

BASIC IP ADDR. PC COM WIFI GLOBAL SV. SYNC.

Menu name	Specification
REMOTE OPERATION	Select and set whether or not to use the cloud function (Global Service).
SSH PORT	Set the SSH port number.

2.2.6 MACHINE No. (SYNC.)

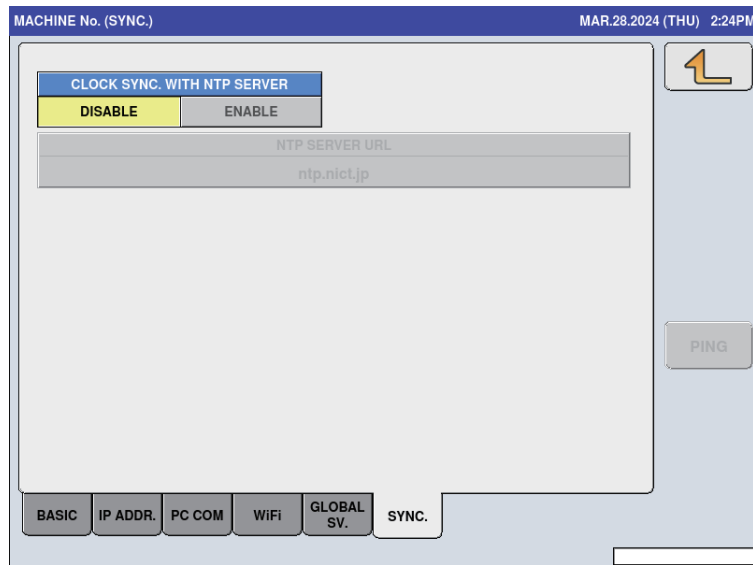

Menu name	Specification
CLOCK SYNC. WITH NTP SERVER	Select and set whether or not to use the clock synchronization.
SERVERNTP SERVER URL	Set the URL of NTP server. When this function is not in use, the option is grayed out. Press the button to open the Editor screen to edit.

2.2.7 MACHINE No. (OUTSIDE PRINTER)

No.	IP ADDRESS
1	0.0.0.0

PING

BASIC IP ADDR. PC COM WiFi GLOBAL SV. OUTSIDE PRN SYNC.

Menu name	Specification
IP ADDRESS	Set the IP address of the printer when the LAN connection is selected.

2.3 Password (Operate)

MENU NAME	SELECT	
PREPACK	ENABLE	DISABLE
ACC1	ENABLE	DISABLE
ACC2	ENABLE	DISABLE
ACC3	ENABLE	DISABLE
TOTAL ADJUST	ENABLE	DISABLE
	ENABLE	DISABLE
	ENABLE	DISABLE

Menu name	Specification
PASSWORD	Set the password in six digits. Logging in by this password will release the menu operation prohibited status.
MENU NAME	Display the menu name. Both USE and NO USE for SALES are grayed out because SALES cannot be locked with the password.
SELECT	Select whether or not to lock with the password. ENABLE: Locked DISABLE: Not locked

(All tabs have the same operations so their explanations are omitted here.)

MENU NAME	SELECT	
PROD. DAILY TOTAL	ENABLE	DISABLE
PROD. WEEKLY TOTAL	ENABLE	DISABLE
PROD. CUM. TOTAL	ENABLE	DISABLE
TRACE. TOTAL	ENABLE	DISABLE
ANALYSIS	ENABLE	DISABLE
TOTAL CLEAR	ENABLE	DISABLE
	ENABLE	DISABLE

MENU NAME	SELECT	
PLU	ENABLE	DISABLE
CAMPAIGN	ENABLE	DISABLE
TRAY	ENABLE	DISABLE
PRESET KEY	ENABLE	DISABLE
SCHEDULER	ENABLE	DISABLE
STORE	ENABLE	DISABLE
DEPARTMENT	ENABLE	DISABLE

PASSWORD (SETUP) MAR.28.2024 (THU) 2:24PM 1/1

PASSWORD 000000

MENU NAME	SELECT	
MACHINE No.	ENABLE	DISABLE
PASSWORD	ENABLE	DISABLE
KEY LOCK	ENABLE	DISABLE
DATA STORAGE	ENABLE	DISABLE
PLU OVERWRITE	ENABLE	DISABLE
PLU INITIAL DATA	ENABLE	DISABLE
PLU UPDATE	ENABLE	DISABLE

OPERATE TOTAL PROGRAM SETUP ADJUST

PASSWORD (ADJUST) MAR.28.2024 (THU) 2:24PM 1/1

PASSWORD 000000

MENU NAME	SELECT	
DATE TIME	ENABLE	DISABLE
TOUCH SCREEN	ENABLE	DISABLE
DISPLAY CHECK	ENABLE	DISABLE
SOUND	ENABLE	DISABLE
FIRMWARE DETAILS	ENABLE	DISABLE
	ENABLE	DISABLE
	ENABLE	DISABLE

OPERATE TOTAL PROGRAM SETUP ADJUST

2.4 Key Locks

2.4.1 KEY LOCK (DISPLAY KEY)

KEY LOCK (DISPLAY KEY) MAR.28.2024 (THU) 2:24PM 1/1

PASSWORD 

KEY NAME	KEY LOCK	
PLU NAME AREA	YES	NO
TARE	YES	NO
WEIGHT/PRICE	YES	NO
PCS	YES	NO
	YES	NO
	YES	NO
	YES	NO

Menu name	Specification
PASSWORD	Set the password in six digits. Normally in the PRODUCTION screen, enter this password and press KEY LOCK FUNCTION to release the input prohibited status.
KEY NAME	Display the measurement menu on the normal mode screen.
KEY LOCK	Select whether or not to set a key lock. YES: The key lock is set. NO: The key lock is not set.

2.4.2 KEY LOCK (FUNCTION KEY)

KEY LOCK (FUNCTION KEY) MAR.28.2024 (THU) 2:24PM 1/17

PASSWORD 

KEY NAME	KEY LOCK	
PLU	YES	NO
TARE	YES	NO
FIX PRICE	YES	NO
MULTIPLY	YES	NO
SPECIAL	YES	NO
-\$	YES	NO
-%	YES	NO



Menu name	Specification
PASSWORD	Set the password in six digits. Normally in the PRODUCTION screen, enter this password and press KEY LOCK FUNCTION to release the input prohibited status.
KEY NAME	Display the function key name.
KEY LOCK	Select whether or not to set a key lock. YES: The key lock is set. NO: The key lock is not set.

2.4.3 KEY LOCK (STROKE KEY)

KEY LOCK (STROKE KEY) MAR.28.2024 (THU) 2:25PM 1/1

PASSWORD 

KEY NAME	KEY LOCK	
	YES	NO
TARE	YES	NO
UNIT PRICE	YES	NO
FIXED PRICE	YES	NO
PRESET	YES	NO
	YES	NO
	YES	NO
	YES	NO

Menu name	Specification
PASSWORD	Set the password in six digits. Normally in the PRODUCTION screen, enter this password and press KEY LOCK FUNCTION to release the input prohibited status.
KEY NAME	Display the stroke key name.
KEY LOCK	Select whether or not to set a key lock. YES: The key lock is set. NO: The key lock is not set.

2.5 Data Storage

2.5.1 DATA STORAGE (TOTAL ADD.)

MENU NAME	SELECT	
	NON ADD	ADD
DAILY TOTAL	NON ADD	ADD
WEEKLY TOTAL	NON ADD	ADD
CUMULATIVE TOTAL	NON ADD	ADD
TIME TOTAL	NON ADD	ADD
OPERATOR TOTAL	NON ADD	ADD
ACC1 TOTAL	NON ADD	ADD
ACC2 TOTAL	NON ADD	ADD
ACC3 TOTAL	NON ADD	ADD

TOTAL ADD. TOTAL PROC. TRANSACTION STORAGE

Menu name	Specification
MENU NAME	Display the menu name.
SELECT	Select whether or not to add. NON ADD / ADD
The TOTAL PROC. / TRANSACTION / STORAGE tabs are displayed only when you access above menus after logging in with the service password.	

2.5.2 DATA STORAGE (TOTAL PROC.)

Menu name	Specification
FIX PRICE ITEM ADD WEIGHT	Select the addition weight of fixed-price items. FIX WEIGHT / REAL WEIGHT
WRAP MODE WEIGHT ADD	Select and set whether or not to perform Weight Add in the production in the WRAP mode.

2.5.3 DATA STORAGE (TRANSACTION)



Menu name	Specification
PROD. TRANSACTION	Select whether or not to add the product transaction. NON ADD / ADD
TRANS. MEM. FULL	Select between stopping or overwriting the transaction addition at full memory condition. STOP / OVERWRITE

2.5.4 DATA STORAGE (STORAGE)

The screenshot shows a software interface for setting data storage. The title bar reads 'DATA STORAGE (STORAGE)' and 'MAR.28.2024 (THU) 2:25PM'. A central panel titled 'TRANSACTION' contains three buttons: 'BUILT-IN (OFFLINE TRAN)', 'CARD', and 'USB'. The 'USB' button is highlighted in yellow. Below this panel is a row of four buttons: 'TOTAL ADD.', 'TOTAL PROC.', 'TRANSACTION', and 'STORAGE'. A small icon is visible in the top right corner of the main panel.

Menu name	Specification
TRANSACTION	Select where to save the transaction. BUILT-IN / USB

2.6 PLU Overwrite

PLU OVERWRITE		MAR.28.2024 (THU) 2:25PM	1/5
PLU MASTER LIST	SELECT		 
UNIT PRICE:FIX PRICE	YES	NO	
MARKDOWN MODE:M/D AMOUNT	YES	NO	
UNIT TYPE:QUANTITY	YES	NO	
FIXED WEIGHT	YES	NO	
PACK DATE/TIME	YES	NO	
SELL BY DATE/TIME	YES	NO	
TARE	YES	NO	
EXTRA MSG.1	YES	NO	
INGREDIENT	YES	NO	
EXTRA MSG.3	YES	NO	

Menu name	Specification
PLU MASTER LIST	Display the PLU master item.
SELECT	Select whether or not to automatically update the PLU master item. YES / NO

2.7 PLU Initial Data

2.7.1 PLU INITIAL DATA (SALE1)

The screenshot shows the 'PLU INITIAL DATA (SALE1)' screen. The title bar displays 'PLU INITIAL DATA (SALE1)' on the left and 'MAR.28.2024 (THU) 2:25PM' on the right. The main area contains several data entry fields:

- SALES MODE:** 0:WEIGHT
- UNIT PRICE:** 0.00
- OPEN PRICE:** 0:YES
- FIXED WGT:** 0.000
- TARE:** 0.000
- MARKDOWN MODE:** 0:NORMAL
- M/D AMOUNT:** 0.00
- 2nd TARE:** 0.000
- UNIT TYPE:** 0:NO PRN
- QUANTITY:** 0
- % TARE:** 0.0
- LOWER WGT:** 0.000
- UPPER WGT:** 0.000
- FORCED TARE:** YES / NO

At the bottom, there is a navigation bar with buttons: SALE1, MSG., IMAGE, PRINT, DATE, CODE, WRAP, SCHEME, and TARGET. A large orange button with a '/' symbol is positioned on the right side of the screen.

Menu name	Specification
	Used to enter fractions. (Valid only when entering the fixed No. of items.) Other tabs also have the same function.
(Each item)	Set the initial value to newly create the PLU master.

2.7.2 PLU INITIAL DATA (MSG.)

PLU INITIAL DATA (MSG.) MAR.28.2024 (THU) 2:25PM 1/3

NUTRITION	0	NONE
EXTRA MSG.1	0	NONE
INGREDIENT	0	NONE
EXTRA MSG.3	0	NONE
COUPON MSG.	0	NONE
POP MSG.	0	NONE
FREE MSG.1	0	NONE
FREE MSG.2	0	NONE

SALE1
MSG.
IMAGE
PRINT
DATE
CODE
WRAP
SCHEME
TARGET

Menu name	Specification
(Each item)	Set the initial value to newly create the PLU master.

2.7.3 PLU INITIAL DATA (IMAGE)

PLU INITIAL DATA (IMAGE) MAR.28.2024 (THU) 2:25PM

IMAGE 1 0

IMAGE 2 0

IMAGE 3 0

SH. IMAGE 0

SAFE HANDLING IMAGE

NO PRINT

PRINT

SALE1 MSG. IMAGE PRINT DATE CODE WRAP SCHEME TARGET

Menu name	Specification
(Each item)	Set the initial value to newly create the PLU master. Pressing an image number item displays the image list.

2.7.4 PLU INITIAL DATA (PRINT)

PLU INITIAL DATA (PRINT) MAR.28.2024 (THU) 2:26PM

1st LABEL ATTACH TYPE < 0:REFER >	2nd LABEL TYPE < 1:NO >	1st LABEL BAR PRINT < 1:YES >
1st LABEL FORMAT No. 0	2nd LABEL FORMAT No. 0	
PRINT MODE < 1:YES >	1st LABEL PRINT < 1:YES >	2nd LABEL PRINT < 1:YES >
SUB LABEL PRINT < 1:YES >	EYECATCH LABEL PRINT < 1:YES >	UPPER FIX FORMAT No. 0

SALE1 MSG. IMAGE PRINT DATE CODE WRAP SCHEME TARGET

Menu name	Specification
(Each item)	Set the initial value to newly create the PLU master.

2.7.5 PLU INITIAL DATA (DATE)

PLU INITIAL DATA (DATE) MAR.28.2024 (THU) 2:26PM

PACK DATE PRINT <input checked="" type="checkbox"/> YES <input type="checkbox"/> NO	PACK TIME PRINT <input type="button" value="←"/> 0:NO PRINT <input type="button" value="→"/>	PACK TIME DATA
SELL BY DATE PRINT <input checked="" type="checkbox"/> YES <input type="checkbox"/> NO	SB TIME PRINT <input type="button" value="←"/> 0:NO PRINT <input type="button" value="→"/>	SB TIME DATA 0 MIN.(S) AFTER
SHELF LIFE(days) NEXT DAY(1 day)	USE BY DATE PRINT <input type="checkbox"/> YES <input checked="" type="checkbox"/> NO	UB DATE DATA
DATE CAL <input type="checkbox"/> YES <input checked="" type="checkbox"/> NO		

SALE1	MSG.	IMAGE	PRINT	DATE	CODE	WRAP	SCHEME	TARGET
-------	------	-------	-------	------	------	------	--------	--------

Menu name	Specification
(Each item)	Set the initial value to newly create the PLU master.

2.7.6 PLU INITIAL DATA (CODE)

The screenshot shows a software interface for setting PLU initial data. The title bar reads 'PLU INITIAL DATA (CODE)' and 'MAR.28.2024 (THU) 2:26PM'. The main area contains several data entry fields:

- ITEMCODE:** 00000000
- REG. CODE:** 0
- POS FLAG:** 02
- BARCODE:** 00000000000000
- POS REFERENCE:** < 0:REFER >
- BARCODE TYPE:** 0:REFER
- POS FORMAT:** REFER
- DEPARTMENT:** 0
- GROUP:** 00

At the bottom of the screen, there is a row of buttons: SALE1, MSG., IMAGE, PRINT, DATE, CODE, WRAP, SCHEME, and TARGET.

Menu name	Specification
(Each item)	Set the initial value to newly create the PLU master.

2.7.7 PLU INITIAL DATA (WRAP)

PLU INITIAL DATA (WRAP) MAR.28.2024 (THU) 2:26PM



<div style="background-color: #4CAF50; color: white; padding: 2px; font-weight: bold; font-size: 0.8em;">TRAY No.</div> <div style="border: 1px solid gray; padding: 5px; text-align: center; font-size: 1.2em;">0</div>	<div style="background-color: #4CAF50; color: white; padding: 2px; font-weight: bold; font-size: 0.8em;">WRAP MODE</div> <div style="border: 1px solid gray; padding: 5px; text-align: center; font-size: 1.2em;"> < 1:WRAP+LABEL > </div>	<div style="background-color: #4CAF50; color: white; padding: 2px; font-weight: bold; font-size: 0.8em;">VOLUME</div> <div style="border: 1px solid gray; padding: 5px; text-align: center; font-size: 1.2em;"> < 0:NONE > </div>
--	--	---

SALE1	MSG.	IMAGE	PRINT	DATE	CODE	WRAP	SCHEME	TARGET
-------	------	-------	-------	------	------	------	--------	--------

Menu name	Specification
(Each item)	Set the initial value to newly create the PLU master.

2.7.8 PLU INITIAL DATA (SCHEME)

The screenshot shows a software interface for setting PLU initial data. The title bar indicates the screen is 'PLU INITIAL DATA (SCHEME)' and the date/time is 'MAR.28.2024 (THU) 2:26PM'. The main content area features a 'TRACE ENABLE' section with two buttons: 'YES' and 'NO'. The 'NO' button is highlighted in yellow, indicating it is the selected option. Below this section is a horizontal menu bar with buttons for 'SALE1', 'MSG.', 'IMAGE', 'PRINT', 'DATE', 'CODE', 'WRAP', 'SCHEME', and 'TARGET'. The 'SCHEME' button is currently selected and highlighted.

Menu name	Specification
(Each item)	Set the initial value to newly create the PLU master.

2.7.9 PLU INITIAL DATA (TARGET)

PLU INITIAL DATA (TARGET) MAR.28.2024 (THU) 2:26PM



TARGET FLAG	QUANTITY
NONE	
TARGET LEVEL1	0
TARGET LEVEL2	0
TARGET LEVEL3	0

SALE1
MSG.
IMAGE
PRINT
DATE
CODE
WRAP
SCHEME
TARGET

Menu name	Specification
(Each item)	Set the initial value to newly create the PLU master.

2.8 PLU Update

PLU UPDATE MAR.28.2024 (THU) 2:26PM 1/14

CHANGE RANGE

START No.	END No.
1	99999999

UNIT PRICE No.					CONDITION	
1	2	3	4	5	NO	YES

No.	LIST NAME	REPLACE CONDITION	CHANGE CONTENTS
1	ITEM CODE		
2	PACK DATE PRINT		
3	PACK TIME PRINT		
4	PACK TIME DATA		
5	SELL BY DATE PRINT		
6	SELL BY TIME PRINT		

BATCH DELETE

EXEC

Menu name	Specification
START No.	Set the start No. of the batch change range. Input range: 1 to 99999999
END No.	Set the end No. of the batch change range. Input range: 1 to 99999999
UNIT PRICE No.	Set the unit price No. for the batch change. Touch the button to change the selection.
CONDITION	Select whether or not to specify the replacement condition for the batch change. NO / YES
LIST NAME	Display the item for the batch change. Touch the button to change the selection.
REPLACE CONDITION	Specify the replacement condition. This function is enabled when [YES] is selected in [CONDITION].
CHANGE CONTENTS	Specify the replacement contents.
BATCH DELETE	Cancel all selections.
EXEC	Execute the batch change. The ALL REUPDATE CHECK dialog appears to ask whether to execute the batch change.

2.9 Label Combination

2.9.1 LABEL COMB

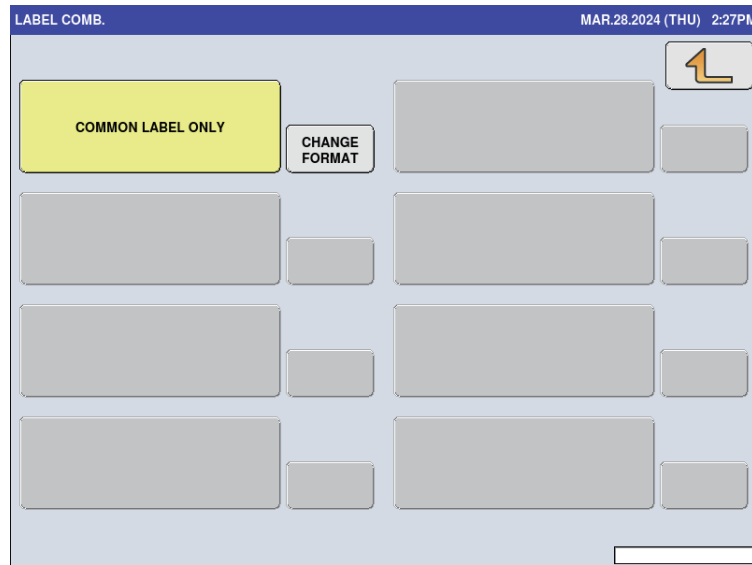

Menu name	Specification
CHANGE FORMAT	Open the LABEL COMB. (BASIC) screen.
COMMON LABEL ONLY	Set the print pattern to [COMMON LABEL ONLY].

2.9.2 LABEL COMB. (BASIC)

The screenshot shows a software interface titled "LABEL COMB.(BASIC)". At the top right, it displays the date and time: "MAR.28.2024 (THU) 2:27PM" and a page indicator "1/1". Below the title bar, there is a "LABEL GROUP" section with four tabs: "EXT. ATTACH", "INT. ATTACH", "SUB", and "TOTAL". The main area contains a table with the following columns: "LABEL TYPE", "PRINTER", "FORMAT No.", and "LABEL PRINT". The first row is highlighted in yellow and contains the text "NORMAL LABEL", "PRINTER 1", "1", "YES", and "NO". Below this row are five more rows, each with "YES" and "NO" options. To the right of the table are four buttons: "FEED", "PRINT", "MODIFY FORMAT", and "DETAIL". At the bottom left, there are three tabs: "BASIC", "LABEL", and "UPPER FIX".

Menu name	Specification
LABEL GROUP	Select the label group to display in the list.
LABEL TYPE	Select the label type.
PRINTER	Display the printer to print the label type displayed in the left. Pressing this button sets to the feed format of the printer.
FORMAT No.	Display the format used to print the label type displayed in the left. Input range: 1 to 999
LABEL PRINT	Set whether to print the label when the print condition is satisfied.
MODIFY FORMAT	Move to the FORMAT EDIT screen to edit the selected format.
DETAIL	Move to the LABEL COMB. /DETAIL screen.

2.9.3 LABEL COMB. (LABEL)

Menu name	Specification
PRINTER	Select or set the printer by entering the number. Only the printer connected can be set.
LABEL No.	Set the label master No. Input range: 1 to 99 If there is no set master, the [LABEL SETTING MASTER IS NOT PROGRAMMED] dialog appears to ask whether to create a new master.
LABEL TYPE	Select the label type. 0: RECEIPT / 1: 130LA-1 / 3: 150LA-1
PRINT DENSITY	Set the print density. Input range: 0 to 9
PRINT DIRECTION	Set the print direction. STAND. / REVERSE
LABEL GAP	Set the label gap. Input range: 0 to 99.9
SENSOR TYPE	Set the sensor type. 0: NO USE / 1: LABEL / 2: MARK
PRINT SPEED	Set the print speed. Input range: 60 to 130
BACK FEED	Select whether or not to set the back feed. NO/YES
SENSOR DISTANCE	Set the label sensor distance. Input range: 0 to 99.9 (Initial data: 51.0)
FEED LENGTH	Set the feed length. Input range: 0 to 99.9

Menu name	Specification
PRE-STOP POS.	When printing the second line, feeding of the printed label is stopped and resumed again immediately when the pasting machine absorbs the label. This option sets the label feeding distance to the position from the edge of head front at the temporal stop of the label feeding. Input range: 0 to 99.9
(CONFIRM TO PRINT) FMT No.	Set the test print label format. Input range: 1 to 999
(CONFIRM TO PRINT) PLU No.	Set PLU No. to use for test printing. Input range: 00000000 to 99999999
(FORMAT INFO) WIDTH	Display the format width for the test print.
(FORMAT INFO) LENGTH	Display the format length for the test print.
CASSETTE No.	Display the cassette No. Only for display

2.9.4 LABEL COMB. (UPPER FIX)

The screenshot shows a software interface for setting up label printing. The title bar reads 'LABEL COMB.(UPPER FIX)' and 'MAR.28.2024 (THU) 2:27PM'. The main display area has three input boxes: 'PRINTER' (value: PRINTER 1), 'FORMAT No.' (value: 1), and 'CASSETTE No.' (empty). On the right side, there are four buttons: 'FEED', 'PRINT', 'MODIFY FORMAT' (highlighted in green), and 'DETAIL'. At the bottom, there are three tabs: 'BASIC', 'LABEL', and 'UPPER FIX' (which is the active tab).

Menu name	Specification
PRINTER	When the paste type is set to FIXED, display the printer to print the label. Move to the PRINTER SELECT screen.
FORMAT No.	When the paste type is set to FIXED, set the format to be used in the label printing. Input range: 1 to 999
CASSETTE No.	When the paste type is set to FIXED, set the cassette to use for label printing. Only printers including cassettes can be set.
MODIFY FORMAT	Move to the FORMAT EDIT screen to edit the selected format.





2.9.5 LABEL COMB. / DETAIL

LABEL COMB. / DETAIL							MAR.28.2024 (THU) 2:27PM		1/2
LABEL TYPE	PRINTER	FORMAT	CASSET.	LABEL PRINT		CONDITION			
NORMAL LABEL	PRINTER 1	1	1	YES	NO	NO CONDITION			
EYECATCH IMAGE LABEL	PRINTER 1	23	1	YES	NO	W/EYECATCH IMAGE			
EYECATCH PRICE LABEL	PRINTER 1	28	1	YES	NO	W/CAMPAIGN PRICE			
CAMPAIGN COMMENT LABEL	PRINTER 1	0	1	YES	NO	W/CAMPAIGN COMMENT			
CAMPAIGN ORIGIN LABEL	PRINTER 1	0	1	YES	NO	W/CAMPAIGN ORIGIN			
BARCODE LABEL	PRINTER 1	1	1	YES	NO	B LB: [UNDER BAR]			
INGREDIENTS ONLY LABEL	PRINTER 1	53	1	YES	NO	B LB: [INGR.]			
INGREDIENTS BARCODE LABEL	PRINTER 1	54	1	YES	NO	B LB: [INGR. + BAR]			
TOTAL/SUBTTL	PRINTER 1	97	1	YES	NO	TOTAL/SUBTOTAL TOTAL LABEL			

Menu name	Specification
PRINTER	Display the printer for label printing. Move to the PRINTER SELECT screen.
FORMAT	Set the format to be used in the label printing. Input range: 1 to 999
CASSET.	Display the cassette No. to be used in the label printing.
LABEL PRINT	Set whether or not to perform label printing when the label printing conditions are satisfied.
CONDITION	Move to the PRINT CONDITION SELECT screen (When the label group is "reversely pasted label, total label", the print condition cannot be changed.)
FORMAT EDIT	To edit the selected format, move to the FORMAT EDIT screen.
INITIAL	Initialize the printing pattern.

2.10 Label Format

2.10.1 LABEL FORMAT

LABEL FORMAT				MAR.28.2024 (THU) 2:28PM	1/5
No.	DESCRIPTION	WIDTH (mm)	HEIGHT (mm)		
1		60.0	37.0		
2		60.0	80.0		
3		60.0	82.0		
4	USA	56.0	73.0		
5	USA	56.0	59.0		
6	USA COUPON	56.0	84.0		
7	USA NUTRITION	56.0	146.0		
11	USA	56.0	60.0		
12		80.0	60.0		
20		60.0	55.0		

Menu name	Specification
PRINT CONTROL	Open the PRINT CONTROL screen.
DETAIL	Move to the LABEL FORMAT/DETAIL (BASIC) screen.
DELETE	Return the selected format to the default status.
No.	Display the format No.
DESCRIPTION	Display the format title.
WIDTH	Set the format width. Input range: 0 to 800
HEIGHT	Set the format height. Input range: 0 to 2000

2.10.2 LABEL FORMAT / PRINT CONTROL

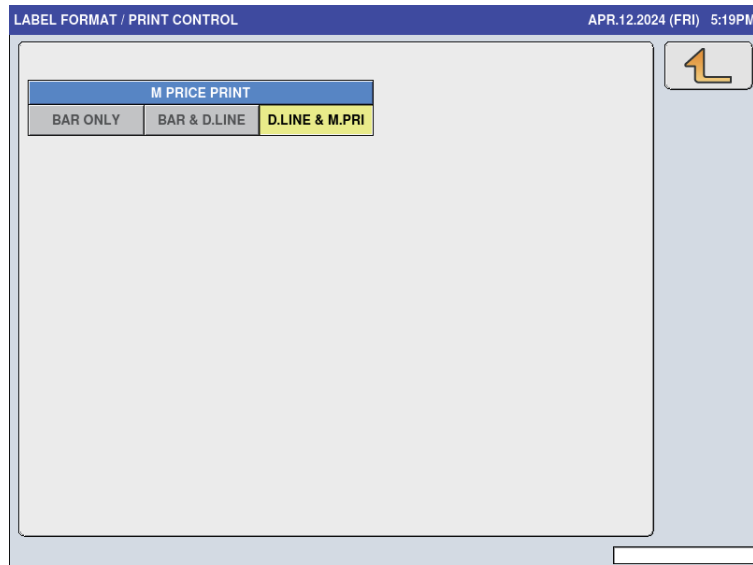

Menu name	Specification
M PRICE PRINT	Select the M price print. BAR ONLY / BAR & D. LINE / D. LINE & M.PRI

2.10.3 LABEL FORMAT / DETAIL (BASIC)

Menu name	Specification
FORMAT NAME	Touch the button to open the format name edit screen. Touch "<" and ">" located at both sides of the box to select the next (or previous) format master.
UNIT No.	Display the unit No. Touch the button to open the unit list set for the current format. The UNIT tab also has the same function.
UNIT NAME(ID)	Display the selected unit name. If nothing is selected, [HEADER] is selected.
PRINTER	Select the printer No.
PLU No.	Set the PLU No. to be used for the test print and preview. Input range: 1 to 99999999 For 0, print the checker label.
LABEL No.	Specify the label No. Input range: 1 to 99
WIDTH	Set the format width. Input range: 0 to 800
HEIGHT	Set the format height. Input range: 0 to 2000
X-AXIS	Display the X axis of selected unit. The axis is moved by entering the numerical number.
Y-AXIS	Display the Y axis of selected unit. The axis is moved by entering the numerical number.
FEED	Feed the label.
PRINT	Perform test printing by the format called and the item information set by PLU No.

Menu name	Specification
UNIT ERASE	Delete the selected unit.
COPY	Enter the numerical number and press COPY to copy the said numerical number's format.
DELETE	Delete the format master. The dialog appears to ask whether to delete the format master.
←↑→↓	Move the axis of selected unit. If the HEADER is selected, the axis of whole format is moved.

2.10.4 LABEL FORMAT / DETAIL (UNIT)

The screenshot shows the 'LABEL FORMAT / DETAIL (UNIT)' screen. At the top, it displays the title and date/time: 'MAR.28.2024 (THU) 2:28PM'. Below this is a navigation bar with a '1' indicator, left and right arrows, and a 'STRING EDIT' button. The main area contains a table with columns 'UNIT No.', 'UNIT NAME', and buttons 'A', 'B', 'C', 'D', 'E', 'F'. The 'UNIT No.' is '0' and 'UNIT NAME' is 'HEADER'. Below this is a table with columns 'PLU', 'SET CONTENTS', and 'VALUE'. The table contains the following data:

PLU	SET CONTENTS	VALUE
FORMAT No.	Header: 1-99 not able to change	1
X-AXIS	Able to set 0-0800 by 0.1mm	600
Y-AXIS	Able to set 0-5000 by 0.1mm	370
UNIT No.	Able to set 1-63	31
TURN	00:STANDARD 02:REVERSE	00

At the bottom of the screen, there are buttons for 'BASIC', 'UNIT', 'PREVIEW', and 'LABEL'. On the right side, there are buttons for 'FEED', 'PRINT', 'UNIT ERASE', 'UNIT COPY', and 'UNIT ADD'.

Menu name	Specification
FORMAT NAME	Touch the button to open the format name edit screen. Touch "<" and ">" located at both sides of the box to select the next (or previous) format master.
STRING EDIT	Open the format string edit screen. Up to 526 bytes
UNIT No.	Display the unit No. Touch the button to open the unit list set for the current format. The UNIT tab also has the same function.
UNIT NAME(ID)	Display the selected unit name. If nothing is selected, "HEADER" is selected.
ABCDEF	Enter the alphabetical character. For hexadecimal entry.
PLU	Display the name of set item.
SET CONTENTS	Display the set contents.
VALUE	Enter the value for set contents.
FEED	Feed the label.
PRINT	Perform test printing by the format called and the item information set by PLU No.
UNIT ERASE	Delete the selected unit.
UNIT COPY	Enter the numerical number and press COPY to copy the said numerical number's format.
UNIT ADD	Add the unit. The header unit also increases by one at the same time.

2.10.5 LABEL FORMAT / DETAIL (PREVIEW)

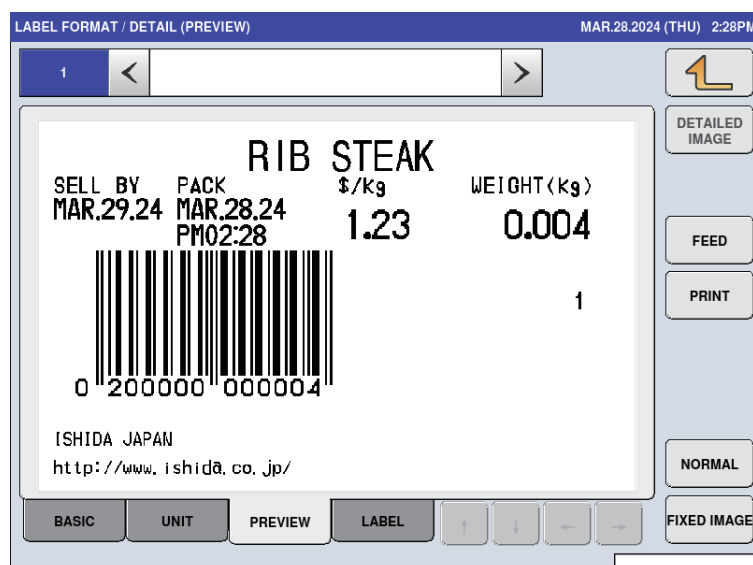

Menu name	Specification
DETAILED IMAGE /WHOLE IMAGE	Select the whole image or detailed image.
FEED	Feed the label.
PRINT	Perform test printing by the format called and the item information set by PLU No.
NORMAL	Set the label type to display. NORMAL / BARCODE / INGREDIENT / INGR. +BAR / SUBTOTAL / TOTAL
FIXED IMAGE	Set whether or not to enable the variable length function of the format. FIXED IMAGE: Enable VIRIABLE IMAGE: Disable
←↑→↓	Move the image. This function is enabled only for the detailed image.

2.10.6 LABEL FORMAT / DETAIL (LABEL)

The screenshot shows the 'LABEL FORMAT / DETAIL (LABEL)' menu. At the top, it displays '1' and navigation arrows. The main area contains several settings:

- EXTEND FORMAT MST.:** NO (highlighted), YES
- PRINTER:** PRN 1
- LABEL TYPE:** LINERLESS
- PRINT DENSITY:** 5
- RED DENSITY:** 5
- PRINT DIRECTION:** STAND. (highlighted), REVERSE
- LABEL GAP:** (empty)
- SENSOR TYPE:** 1:LABEL
- PRINT SPEED:** 120mm/s
- BACK FEED:** NO, YES
- SENSOR DISTANCE:** 0.0mm
- FEED LENGTH:** 15.0mm
- PRE-STOP POS.:** (empty)

At the bottom, there are tabs for 'BASIC', 'UNIT', 'PREVIEW', and 'LABEL'. On the right side, there are buttons for 'FEED', 'PRINT', 'DETAIL' (highlighted in red), and 'DELETE'.

Menu name	Specification
EXTEND FORMAT MST.	Select whether or not to extend label master. YES: Label master is generated for each format and referenced to the settings.
PRINTER	Set the label master No. Input range: 1 to 99 If there is no set master, the [LABEL SETTING MASTER IS NOT PROGRAMMED] dialog appears to ask whether to create a new master.
LABEL TYPE	Select the label type. 0: RECEIPT / 1: 130LA-1 / 3: 150LA-1
PRINT DENSITY	Set the print density. Input range: 0 to 9
PRINT DIRECTION	Set the print direction. STAND. / REVERSE
LABEL GAP	Set the label gap. Input range: 0 to 99.9
SENSOR TYPE	Set the sensor type. 0: NO USE / 1: LABEL / 2: MARK
PRINT SPEED	Set the print speed. Input range: 60 to 130
BACK FEED	Select whether or not to set the back feed. NO/YES
SENSOR DISTANCE	Set the label sensor distance. Input range: 0 to 99.9
FEED LENGTH	Set the feed length. Input range: 0 to 99.9
PRE STOP POS	When printing the second line, feeding of the printed label is stopped and resumed again immediately when the pasting machine absorbs the label. This option sets the label feeding distance to the position from the edge of head front at the temporal stop of the label feeding. Input range: 0 to 99.9

2.11 Barcodes

2.11.1 BARCODE (POS FLAG)

Menu name	Specification
EAN/UPC 13	Set the NON-PLU 13 digits. Input range: 00 to 99
EAN/UPC 8	Set the NON-PLU 8 digits. Input range: 0 to 9
10 DIGITS 13	Set the PLU 13 digits. Input range: 00 to 99
5 DIGITS 8	Set the PLU 8 digits. Input range: 00 to 99

2.11.2 BARCODE (POS CODE)

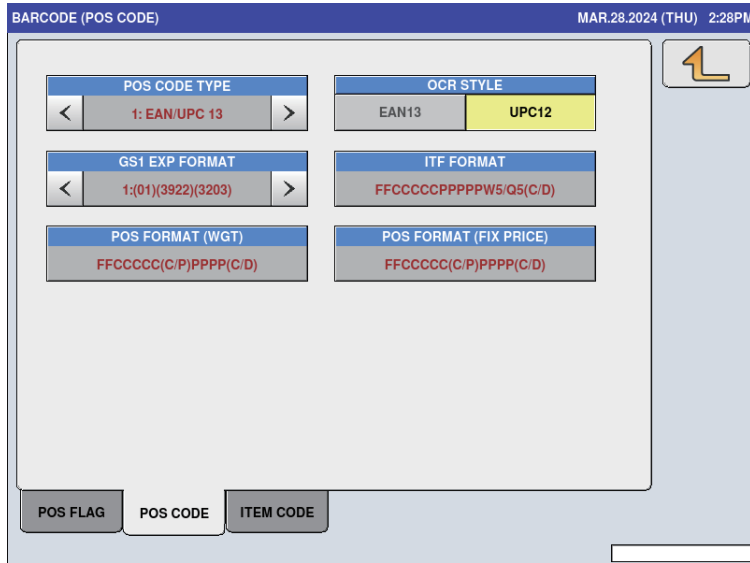

Menu name	Specification
POS CODE TYPE	Select the POS code type. 1: EAN/UPC13 2: EAN/UPC 8/3:10 DIGITS 13/4:5DIGITS 8/5:GS1 6:GS1 ST/7:GS1 STO/8:GS1 LIMITED/9:GS1 EXPANDED/10: ITF
OCR	Select the OCR style. EAN13 / UPC12
GS1 EXP FORMAT	Select the GS1 EXP format. 1:(01) (3922) (3203) / 2:(01) (3922) (3203) (15)
ITF FORMAT	Set the format when POS CODE TYPE is [ITF].
POS FORMAT(WGT)	Select the POS format (weight). Touch the button to open the POS FORMAT list. Select the format from the list.
POS FORMAT (FIX PRICE)	Select the POS format (fix price). Touch the button to open the POS FORMAT list. Select the format from the list.

2.11.3 BARCODE (ITEM CODE)

Menu name	Specification
DEPARTMENT No. DIGIT SET	Execute the digit set of department No. Press the numerical number to switch the selection. Press the numerical number in series. (e.g. The combination of "1" and "3" cannot be selected. The combination of "1", "2" and "3" can be selected.)
GROUP No. DIGIT SET	Execute the digit set of group No. Press the numerical number to switch the selection. Press the numerical number in series. (e.g. The combination of "1" and "3" cannot be selected. The combination of "1", "2" and "3" can be selected.)
EAN/UPC 13 DIGIT SET	Execute the digit set of JAN code (13 digits). Press the numerical number to switch the selection. Press the numerical number in series. (e.g. The combination of "1" and "3" cannot be selected. The combination of "1", "2" and "3" can be selected.)
EAN/UPC 8 DIGIT SET	Execute the digit set of JAN code (8 digits). Press the numerical number to switch the selection. Press the numerical number in series. (e.g. The combination of "1" and "3" cannot be selected. The combination of "1", "2" and "3" can be selected.)

2.12 Custom Barcodes

2.12.1 CUSTOM BARCODE

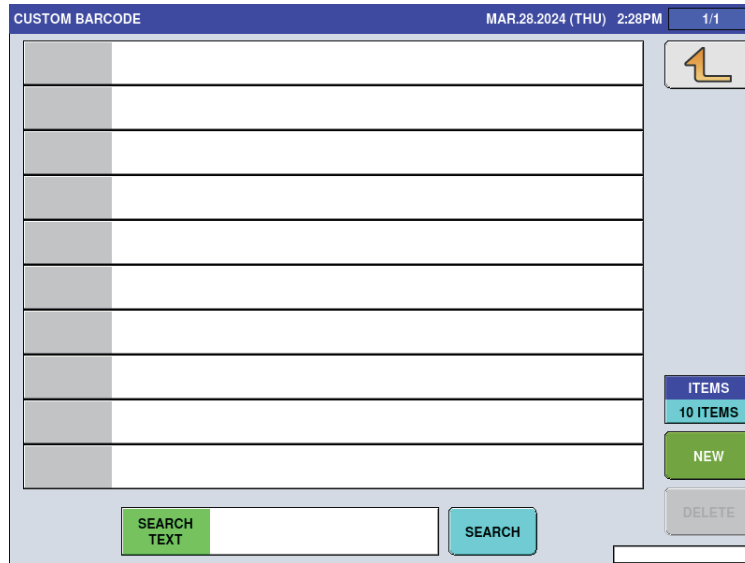

Menu name	Specification
ITEMS	Switch the display items between "10 items" and "20 items".
DETAIL	Move to the CUSTOM BARCODE (BASIC) screen, and display the details of custom bar code in selection.
DELETE	Delete the selected line.
SEARCH TEXT	<p>Move to the CUSTOM BARCODE / SEARCH TEXT EDIT screen.</p>
SEARCH	<p>Switch the search condition between [SEARCH] and [CANCEL].</p> <p>SEARCH: Display data including [SEARCH TEXT] in a list.</p> <p>CANCEL: Display all the data in a list.</p>

2.12.2 CUSTOM BARCODE (BASIC)

No.	ID	START	DIGIT	DATA	CTRL
1					

Buttons on the right: PLU (1), FORMAT (1), FORMAT EDIT, INSERT, DELETE.

Buttons at the bottom: BASIC, PREVIEW.

Menu name	Specification
PLU	Set the item No. to be used for the preview. Input range: 1 to 99999999 Other tabs also have the same function.
FORMAT	Input range: 1 to 999 Other tabs also have the same function.
FORMAT EDIT	Open the format edit screen. Other tabs also have the same function.
INSERT	Insert the blank line in front of selected line.
DELETE	Delete the selected line.
No.	Touch the button to switch the selection.
ID	Set the ID to be combined. Touch the button to open the CUSTOM BARCODE ID LIST. Select the ID from the list.
START	Set the start digit. Input range: 1 to 999
DIGIT	Set the digit number. 0: ALL or 1 to 999
DATA	Display the set ID data. Touch the button to open the edit screen only when the ID is set to PRE PRINT.
CTRL	Select the control character. 0: NONE Nothing to process. 1: () Add “()” to the data in the content column of the same row. 4: FNC1 Set the CTRL for the item at the end of the data as “FNC1”.

2.12.3 CUSTOM BARCODE (PREVIEW)

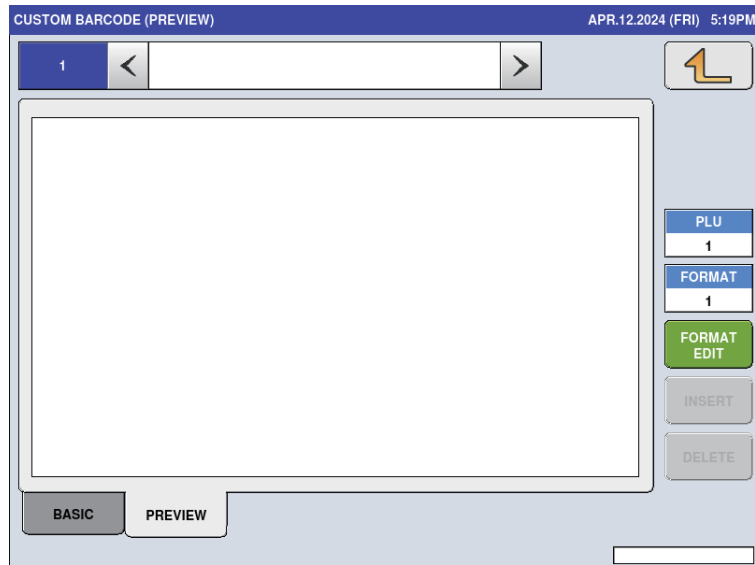

Menu name	Specification
	The combined-barcode preview is displayed only.

2.13 Menu Title (Operate)

No.	DEFAULT NAME	NEW NAME
1001	PREPACK	PREPACK
1003	ACC1	ACC1
1004	ACC2	ACC2
1005	ACC3	ACC3
1002	TOTAL ADJUST	TOTAL ADJUST

OPERATE TOTAL PROGRAM SETUP ADJUST EDIT

Menu name	Specification
DEFAULT NAME	Display the menu name before editing. Touch the button to select the menu name.
NEW NAME	Display the menu name after editing. Touch the button to select the menu name.
EDIT	Transfer to the edit screen of the selected menu name.

(All tabs have the same operations so their explanations are omitted here.)

2.14 Operation Settings

2.14.1 OPERATION SETTING (CALL1)

Menu name	Specification
FIND PLU	Select how to search PLU. START CHAR. / LINE1 / LINE2 / ALL
FREEMASTER FOR URL	Set the freemaster No. to use in the URL. Input range: 0 to 15
PACK MODE HOLD	Select the PACK mode between “fixed to scale” or “set by item”. FIXING / ITEM EACH
STORE CALL	Set whether or not to enable store-switching operations. YES: Enable store number switching using a preset key.
REWRAP MODE	Switch between production mode switching operation and expiry date setting when rewrapping. STD : Production mode can always be switched. Expiry date follows the PLU setting. CALC.: Production mode can be switched only when the product is not called. Expiry date is the day after the pack date.
REWRAP MODE HOLD	Set the fixed operation in REWRAP mode. NO: Return to “TODAY” each time a product call or a zero call is made. YES: Keep the production mode unchanged even if a product call or a zero call is made. The above is valid only when REWRAP MODE is set to “STD”.
SCAN START POSITION	Setting for calling ITEM CODE by scanning EAN13 barcode Set the barcode reading start position.
SCAN DIGIT	Setting for calling ITEM CODE by scanning EAN13 barcode Set the number of barcode reading digits.

2.14.2 OPERATION SETTING (CALL2)

Menu name	Specification
CALL UP UNIT PRICE	Select and set the unit price to be set in the PLU calling. EVERY U/P No.1: 1 is selected for the unit price. LAST CALL UP U/P: the unit No. used latest is selected.
CHANGE MASTER	Select and set the method to be used for each item. PLU: Data permanently set to unit 1 is used. U/P: Data set for each unit is used.

2.14.3 OPERATION SETTING (PROD.)

WEIGHED ITEMS' WEIGHT RANGES CHECK		LABEL SERIAL START No.	
<input type="radio"/> NO	<input type="radio"/> YES	1	
TARE SELECT		LABEL SERIAL END No.	
<input type="radio"/> 1st TARE	<input type="radio"/> 2nd TARE	99999	
FIX PRICE ITEMS' WEIGHT RANGES CHECK		LABEL SER. No. DAILY AUTO CLEAR	
<input type="radio"/> NO	<input type="radio"/> YES	<input type="radio"/> NO <input type="radio"/> YES	
<input type="radio"/> @for SET	<input type="radio"/> END OF DAY	LABEL SERIAL COUNT No.	
<input type="radio"/> NO	<input type="radio"/> YES	1	
<input type="radio"/> MEAT CUT TEST		<input type="radio"/> CASE WGT POP UP	
<input type="radio"/> NO	<input type="radio"/> YES	<input type="radio"/> NO <input type="radio"/> YES	
<input type="radio"/> MEAT CUT TEST DEL. SELECT		<input type="radio"/> ManWT oz CALC.	
<input type="radio"/> NON USE		<input type="radio"/> NO <input type="radio"/> YES	

CALL1 CALL2 PROD. PRINT

Menu name	Specification
WEIGHED ITEMS'WEIGHT RANGES CHECK	Select whether or not to check the weight of weighed items. NO / YES
TARE SELECT	Select the tare. 1st TARE / 2nd Tare
FIX PRICE ITEMS' WEIGHT RANGES CHECK	Select whether or not to check the weight of fixed-price product. NO / YES
@for SET	Select and set whether to perform @for calculation (for the fixed price item using "× (MULTI)" key). *Settable only when the country is set to [USA] NO / YES
END OF DAY	Set the time valid for the next day process set for PLU. Input range: 0 to 23
MEAT CUT TEST	Select and set whether to use the Meat Cut Weight Control mode. NO / YES
MEAT CUT TEST DEL. SELECT	Select and set whether to use the DELETE button in the Meat Cut Master Setting screen. NON USE / USE
LABEL SERIAL START No.	Set the start number of the label serial number.
LABEL SERIAL END No.	Set the end number of the label serial number.
LABEL SER. No. DAILY AUTO CLEAR	Select whether or not to clear the current value of the serial number each day. NO / YES
LABEL SERIAL COUNT No.	Set the value to be added for each label issued.

Menu name	Specification
CASE WGT POP UP	Select whether or not to display the fix weight item setting pop up screen when the fix weight item is called. NO / YES
ManWT oz CALC.	Set whether or not to perform the constant weight calculation when MULTI (x) is used. Note: Displayed only when the country setting "USA" is set.

2.14.4 OPERATION SETTING (PRINT.)

Menu name	Specification
TARGET COMPLETE	Select and set the operation when the order is completed. NONE / BUZZER / MESSAGE
AUTO SUBTOTAL LABEL	Select printing of the automatic subtotal label. NONE: Printing is not performed. 1: 1 sheet of subtotal label is printed. 2: 2 sheets of subtotal label are printed. Settable only when the order completion operation selects [MESSAGE].
TARGET AUTO SETUP	Selecting YES sets the same target No. when the target No. setting is completed.
SUBTOTAL CLEAR	Select and set the clear timing of the subtotal data. SUBTOTAL PRINT: Cleared when the subtotal is printed PLU CALL: Cleared when the item is called
AUTO/MANUAL	Select and set the initial value of [PRN MD.] when the screen is moved to OPERATE MODE.
UPPER BAR WHEN UNDER LABEL PRINT	Select and select whether to print the barcode of the 1st LABEL when the 2nd LABEL is printed.
CALENDAR INPUT	If YES, the calendar screen opens in normal mode when the PACK DATE or EXPIRY DATE button is pressed.

2.15 Error Processes

2.15.1 ERROR PROCESS (ISSUE)

Menu name	Specification
PRINTING AT 0 PRICE	Select the action of printing at 0. BARCODE=0 No PRICE / No BAR.PRICE=0 / No BAR. No PRICE The currency unit depends on the country master.
DISPLAY ERROR: TARE WEIGHT NOT SET	Select whether or not to display the error message when the tare weight is not set. NO / YES
DISPLAY ERROR: ZERO PRICE	Select whether or not to display the error message of 0 price. NO / YES
PLU NAME LINES OVER ERROR	Select and set the process when the item line No. is over the set number. ERROR: Display the LINE OVER error, and no item is printed. LINE CUT: Cut the exceeded line, and the item is printed within the display range.

2.15.2 ERROR PROCESS (CALL)

ERROR PROCESS (CALL)
MAR.28.2024 (THU) 2:29PM

NO POS CODE SET ERROR

NO ERROR DISPLAY

NO LABEL PRINT

NO BAR PRINT

ERROR PROCESS

EXTRA MSG.1
NO YES

INGREDIENT
NO YES

EXTRA MSG.3
NO YES

COUPON MSG.
NO YES

POP MSG.
NO YES

FREE MSG.1
NO YES

FREE MSG.2
NO YES

FREE MSG.3
NO YES

FREE MSG.4
NO YES

FREE MSG.5
NO YES

FREE MSG.6
NO YES

FREE MSG.7
NO YES

FREE MSG.8
NO YES

FREE MSG.9
NO YES

FREE MSG.10
NO YES

FREE MSG.11
NO YES

FREE MSG.12
NO YES

FREE MSG.13
NO YES

FREE MSG.14
NO YES

FREE MSG.15
NO YES

ISSUE

CALL

COMMON

Menu name	Specification
NO POS CODE SET ERROR	Select the action when the POS code is not set. NO ERROR DISPLAY / NO LABEL PRINT / NO BAR PRINT
ERROR PROCESS	Set the error display operation when the link master at item calling does not exist. NO / YES

2.15.3 ERROR PROCESS (COMMON)

The screenshot shows a software window titled "ERROR PROCESS (COMMON)" with a timestamp of "MAR.28.2024 (THU) 2:29PM". Inside the window, there is a sub-menu titled "DAMAGED THERMAL HEAD ERROR DISPLAY" with three radio button options: "ON TIME MSG.", "CONTINUOUS MSG." (which is selected and highlighted in yellow), and "NO MESSAGE". At the bottom of the window, there are three tabs labeled "ISSUE", "CALL", and "COMMON", with "COMMON" being the active tab.

Menu name	Specification
DAMAGED THERMAL HEAD ERROR DISPLAY	Select how to set the error message of damaged thermal head. ON TIME MSG / CONTINUOUS MSG / NO MESSAGE

2.16 Error Log (Display)

ERROR LOG (DISPLAY)					MAR.28.2024 (THU) 2:29PM	1/469
DATE/TIME	ERROR No.	PLU	TRAY	ERROR DESCRIPTION		
03/28 14:29:23	30004-0024	0	4	ERROR LOG : MENU -> ERROR LOG (DISPLAY)	⏪	
03/28 14:29:22	30004-0097	0	0	RETURN : ERROR PROCESS (COMMON) -> MENU	⏴	
03/28 14:29:19	30004-0001	0	4	CALL : ERROR PROCESS (CALL) -> ERROR PROCESS (COMMON)		
03/28 14:29:17	30004-0001	0	4	ISSUE : ERROR PROCESS (ISSUE) -> ERROR PROCESS (CALL)		
03/28 14:29:14	30004-0023	0	4	ERROR PROCESS : MENU -> ERROR PROCESS (ISSUE)		
03/28 14:29:12	30004-0097	0	0	RETURN : OPERATION SETTING (PRINT) -> MENU		
03/28 14:29:09	30004-0001	0	4	PROD. : OPERATION SETTING (PROD.) -> OPERATION SETTING (PRINT)		
03/28 14:29:06	30004-0001	0	4	CALL2 : OPERATION SETTING (CALL2) -> OPERATION SETTING (CALL1)		
03/28 14:29:04	30004-0001	0	4	CALL1 : OPERATION SETTING (CALL1) -> OPERATION SETTING (CALL1)		
03/28 14:29:01	30004-0022	0	4	OPERATION SETTING : MENU -> OPERATION SETTING (CALL1)		

DISPLAY DELETE

Menu name	Specification
DELETE	Delete the error log. The DELETE CHECK dialog appears to ask whether to delete the error log.

2.17 Trace

The screenshot shows the TRACE setup screen with the following options:

- TRACEABILITY TYPE:** TYPE1 (selected), TYPE2
- TRACEABILITY TOTAL:** NON ADD (selected), ADD
- LOOKUP TABLE EDIT:** NO (selected), YES
- TRACE. DATA DELETE:** MANUAL, AUTO (selected)
- TRACEABILITY PASSWORD:** 0000
- LOT MANUAL INPUT:** STD, SCAN
- NEW LOT CREATION:** NO (selected), YES

Menu name	Specification
TRACEABILITY TYPE	Select the traceability type. TYPE1 / TYPE2 (TYPE1 is simple traceability.)
TRACEABILITY TOTAL	Select whether or not to add the traceability total. NO / YES
TRACE. DATA DELETE	Select the manual or auto deletion of traceability data. MANUAL / AUTO
TRACEABILITY PASSWORD	Set the traceability password. This function is enabled when [TYPE2] is selected in the TRACEABILITY TYPE. 0 or 4-digit number
LOOKUP TABLE EDIT	Select whether or not to enable the lookup table edit on the traceability screen in the normal mode. NO / YES
LOT MANUAL INPUT	Select how to handle manually input data. This function is enabled when [TYPE2] is selected in the TRACEABILITY TYPE. STD: set the input data as LOT number. SCAN: set the input data according to the rules in SCHEME TABLE. (same as when a barcode is read by a scanner)
NEW LOT CREATION	Select whether or not to allow the generation of new lots by the machine. NO / YES

2.18 Dual Currency

DUAL CURRENCY MAR.28.2024 (THU) 2:29PM

EXCH. RATE	EXCH. RATE DEC. PNT. POS.		
4293	4		
PERIOD SELECTION			
LOCAL+FOREIGN	FOREIGN+LOCAL	LOCAL	FOREIGN
BARCODE PRICE SELECTION			
1st		2nd	
LOCAL CURRENCY SYMBOL	LOCAL CURR. DEC. PNT. POS.		
Lm	2		

Menu name	Specification
EXCH. RATE	Set the exchange rate of the second currency. Input range: 0 to 99999999
EXCH. RATE DEC. PNT. POS.	Set the decimal point position of the exchange rate of the second currency. Input range: 0 to 7
PERIOD SELECTION	Select the currency combination. LOCAL+FOREIGN/FOREIGN+LOCAL/LOCAL/FOREIGN
BARCODE PRICE SELECTION	When using DUAL CURRENCY, select which currency is to be printed in the amount portion of the barcode, the regular currency or the second currency.
LOCAL CURRENCY SYMBOL	Set the local currency symbol. Up to 3 bytes
LOCAL CURR. DEC. PNT. POS.	Set the decimal point position of the local currency. Input range: 0 to 7

2.19 Price Rounding

The screenshot shows a software interface for configuring price and discount rounding. It features two main sections: 'PRICE ROUNDING' and 'DISCOUNT ROUNDING'. The 'PRICE ROUNDING' section contains two buttons: '4/5' (highlighted in yellow) and '05'. The 'DISCOUNT ROUNDING' section contains three buttons: 'DOWN' (highlighted in yellow), '4/5', and 'UP'. A back arrow icon is located in the top right corner of the interface.

Menu name	Specification
PRICE ROUNDING	Select the price rounding type. 4/5 / 05
DISCOUNT ROUNDING	Select the discount rounding type. DOWN / 4/5 / UP

2.20 Frequent Shopper

The screenshot shows a software interface for setting up a 'Frequent Shopper' menu. The title bar reads 'FREQUENT SHOPPER' and the system clock shows 'MAR.28.2024 (THU) 2:29PM'. The main content area has a light gray background. In the center, there are two stacked input boxes. The top box is titled 'BARCODE PRICE TYPE' and contains two buttons: 'NORMAL' and 'MARKDOWN'. The bottom box is titled 'LOGO IMAGE 1 No.' and contains the text '000'. In the top right corner of the main area, there is a small icon of a right-pointing arrow with a blue outline. At the bottom right of the screen, there is a small white rectangular button.

Menu name	Specification
BARCODE PRICE TYPE	Select the barcode price type. NORMAL / MARKDOWN
LOGO IMAGE 1 No.	Set the logo image 1 No. Input range: 0 to 999

2.21 Standby Mode

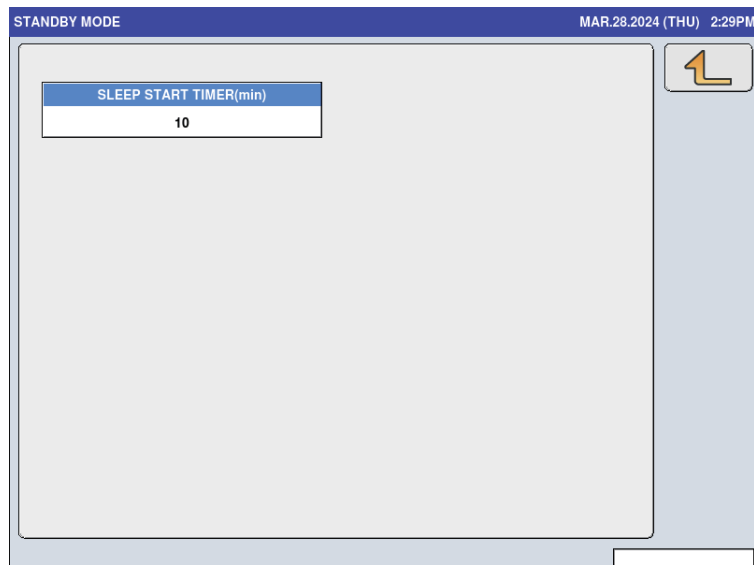

Menu name	Specification
SLEEP START TIMER(min)	Set the time to standby mode. The unit is in minutes.

2.22 Country

2.22.1 COUNTRY

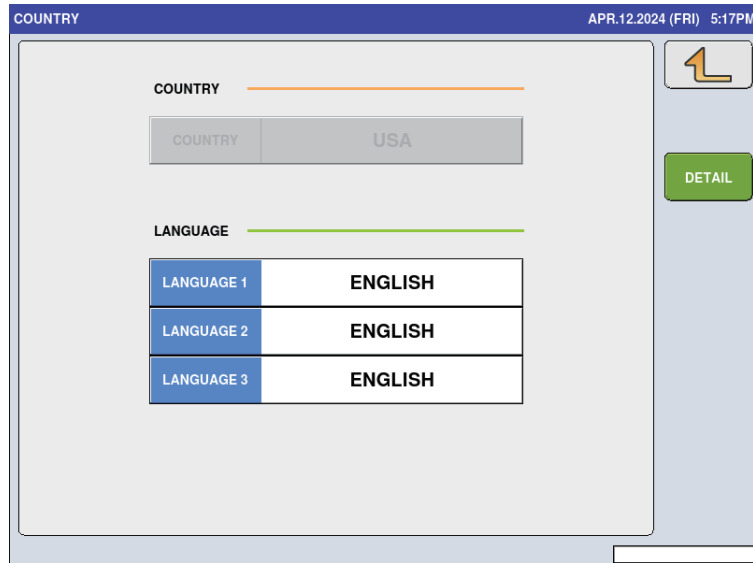

Menu name	Specification
COUNTRY	Select the country. Enter 951753 and press PLU to enable this function. Touch the COUNTRY button to open the list and select the country.
LANGUAGE	Set the first to third language. Touch the button to open the list and select the language.
DETAIL	Transfer to the country setting details screen. Enter 495344 and press PLU to open the screen.

2.22.2 Country / Detail (Currency)

The screenshot displays the 'COUNTRY / DETAIL (CURRENCY)' configuration window. The title bar shows the date and time as 'APR.12.2024 (FRI) 5:17PM'. The main area contains several input fields: 'CURRENCY SYMBOL' with the value '\$', 'DEC. POINT POSITION' with the value '2', and 'DEC. POINT TYPE' with a dot '.' selected. The 'TEMPERATURE' section has two radio buttons, '°C' and 'F', with 'F' being the active selection. A red 'INIT.' button is located at the bottom right of the main area. At the bottom of the window, there are three tabs: 'CURRENCY', 'WEIGHT', and 'DATE', with 'CURRENCY' currently selected.

Menu name	Specification
CURRENCY SYMBOL	Set the currency symbol. Up to 3 bytes
DEC. POINT POSITION	Set the decimal point position of currency. Input range: 0 to 7
DEC. POINT TYPE	Select the decimal point type. . / , (dot / comma)
TEMPERATURE	Select and set the temperature unit. °C / F
INIT.	Initialize the set value of country master. Other tabs also have the same function.

2.22.3 Country / Detail (Weight)

The screenshot displays the 'COUNTRY / DETAIL (WEIGHT)' configuration screen. At the top, it shows the title 'COUNTRY / DETAIL (WEIGHT)' and the date/time '01-09-2023 (FRI) 14:13'. The main area contains several settings:

- WEIGHT UNIT:** A selection box with 'kg' highlighted, and options for 'lb' and 'g'.
- MAX. TARE:** A text field containing the value '5998'.
- DEC. POINT POSITION:** A text field containing the value '3'.
- MINIMUM PRINT WGT:** A selection box with '20e' highlighted, and options for '5e' and '3e'.
- DEC. POINT TYPE:** A selection box with '.' highlighted, and an option for ','.

At the bottom of the screen, there are three tabs: 'CURRENCY', 'WEIGHT' (which is active), and 'DATE'. A red 'INIT.' button is located on the right side of the screen. A navigation arrow is also present in the top right corner.

Menu name	Specification
WEIGHT UNIT	Select the weight unit. Lb / kg / g Enter 14789632 and press PLU to enable this function.
MAX. TARE	Set the maximum tare. For the unit of kg or g: 0 to 5998 For the unit of lb: 0 to 9990 Enter 14789632 and press PLU to enable this function.
DEC. POINT POSITION	Set the decimal point position. Input range: 1 to 5 Enter 495344 and press PLU to enable this function.
DEC. POINT TYPE	Select the decimal point type. . / , (dot / comma) Enter 495344 and press PLU to enable this function.
MINIMUM PRINT WGT	Set the minimum print weight. 20e / 5e / 3e Enter 495344 and press PLU to enable this function. This function is enabled only for the manual print.
INIT.	Initialize the set value of country master. Other tabs also have the same function.

2.22.4 COUNTRY / DETAIL (DATE)

The screenshot shows a software interface for configuring date-related settings. The title bar reads 'COUNTRY / DETAIL (DATE)' and the system clock shows 'APR.12.2024 (FRI) 5:18PM'. The main area contains several panels:

- DATE FORMAT:** A dropdown menu currently showing '1:M-D-Y'.
- DATE SPACER:** A row of buttons for different spacers: comma (.), period (.), colon (:), slash (/), space (SPC), ymd, and hyphen (-). The period (.) button is highlighted.
- YEAR TYPE:** Two buttons: 'YY(2)' and 'YYYY(4)'. The 'YYYY(4)' button is highlighted.
- SHELF LIFE-USE BY:** Two buttons: 'Next Day' and 'Today'. The 'Next Day' button is highlighted.
- MONTH TYPE:** Three buttons: 'DIGIT', 'CHAR(3)', and 'CHAR(2)'. The 'CHAR(3)' button is highlighted.

At the bottom, there are tabs for 'CURRENCY', 'WEIGHT', and 'DATE'. A red 'INIT.' button is located in the bottom right corner of the main panel.



Menu name	Specification
DATE FORMAT	Select the date format (order). 0: Y-M-D / 1:M-D-Y / 2: D-M-Y
YEAR TYPE	Select the year type. YY (2) / YYYY (4) Last 2 or 4 digits
MONTH TYPE	Select the month type. DIGIT / CHAR (3) / CHAR (2) Numerical number, three characters or two characters
DATE SPACER	Select the date spacer. , (comma) / . (period) / :(colon) / /(slash) / space / ymd / · (middle point)
SHELF LIFE · USE BY	Select whether or not to set the shelf life "1" to the next day or today. Next Day / Today
INIT.	Initialize the set value of country master. Other tabs also have the same function.

2.23 File Save / Load

2.23.1 FILE SAVE / LOAD (USB>SCALE)

Menu name	Specification
INPUT SOURCE	Display the name of the input source.
INPUT SELECT	Open the FILE SAVE/LOAD IN SELECT screen. The input source is listed only when the files are saved on the USB flash drive.
MASTER NAME	Display the master name. Touch the button to change the selection. Other tabs also have the same function.
NUMBER	Display the number of master data. Other tabs also have the same function.
ALL SEL.	Change the selections of all masters. This function is enabled when the input source file is set. Other tabs also have the same function.
DETAIL	Open the FILE SAVE/LOAD OUT (DETAIL) screen. Other tabs also have the same function.
EXEC	Execute the file input of selected master. The INPUT CHECK dialog appears to ask whether to input the file.

2.23.1.1 FILE SAVE / LOAD / INPUT SELECT

FILE SAVE/LOAD / INPUT SELECT		APR.12.2024 (FRI) 5:20PM	1/1
No.	INPUT	 	
1	BACKUP		
2			
3			
4			
5			
6			
7			
8			
9			
10			

Menu name	Specification
No.	Display the folder No. memorized in the USB memory. Folder "Data01" to "Data10" = №1 to №10
INPUT	Display the data name (index name) named to each master file group "Data01" to "Data10" memorized in the USB memory.
SET	Determine the input source selected, and return to the previous screen.

2.23.2 FILE SAVE / LOAD (SCALE>USB)

Menu name	Specification
OUT SOURCE	Display the name of the output source.
OUTPUT SELECT	Open the FILE SAVE/LOAD OUT SELECT screen. SET: Set the output source. EDIT: Edit the name of the output source.
ALL SEL.	Switch between “All items selected” / “All items unselected”.
DETAIL	Move to the FILE SAVE/LOAD / DETAIL screen.
EXEC	Execute the file output of selected master. The OUTPUT CHECK dialog appears to ask whether to output the file.

2.23.2.1 FILE SAVE / LOAD / OUTPUT SELECT

FILE SAVE/LOAD / OUTPUT SELECT		APR.12.2024 (FRI) 5:20PM	1/1
No.	INPUT		
1	BACKUP	 EDIT SET	
2			
3			
4			
5			
6			
7			
8			
9			
10			

Menu name	Specification
No.	Display the folder No. memorized in the USB memory. Folder "Data01" to "Data10" = №1 to №10
INPUT	Display the data name (index name) named to each master file group "Data01" to "Data10" memorized in the USB memory.
EDIT	Move to the FILE SAVE/LOAD / OUTPUT SELECT / EDIT INDEX NAME screen.
SET	Determine the input source selected, and return to the previous screen.

2.23.3 FILE SAVE / LOAD (USB DATA DEL.)

MASTER NAME	NUMBER

Menu name	Specification
DELETE SELECT	Display the name of the deletion source.
MASTER NAME	Display the master name of the file in the folder of USB memory specified as “Deletion destination”.
ALL SEL.	Switch between “All items selected” / “All items unselected”.
EXEC	Execute the file output of selected master. The OUTPUT CHECK dialog appears to ask whether to output the file.

2.23.3.1 FILE SAVE / LOAD / DELETE SELECT

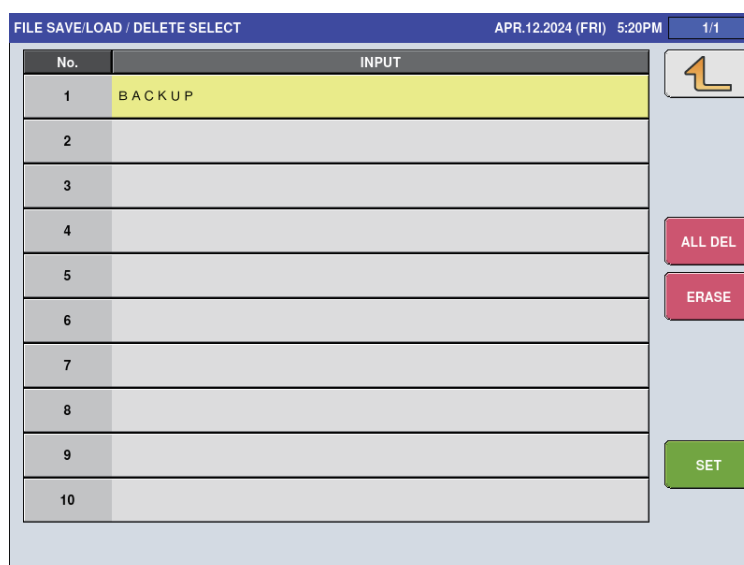

Menu name	Specification
No.	Display the folder No. memorized in the USB memory. Folder "Data01" to "Data10" = №1 to №10
INPUT	Display the data name (index name) named to each master file group "Data01" to "Data10" memorized in the USB memory.
ALL DEL	Delete all the files in the USB memory (folders "Data01" to "Data10").
ERASE	Delete all the files in the selected data folder.
SET	Determine the input source selected, and return to the previous screen.

2.23.4 FILE SAVE / LOAD (SCALE INIT.)

FILE SAVE/LOAD (SCALE INIT.) MAR.28.2024 (THU) 2:30PM 1/9

DATA INTERNAL MASTER

MASTER NAME	NUMBER	MEMORY SPACE
PLU	4 (4)	1,618,696 KB
STORE	2	PLU MASTER CONV. 1786147 EA
FIX PRICE SYMBOL	20	
FREE MSG.1	0	
FREE MSG.2	0	
FREE MSG.3	0	
FREE MSG.4	0	

USB > SCALE SCALE > USB USB DATA DEL. SCALE INIT.

ALL SEL. DETAIL EXEC

Menu name	Specification
DATA	Display the master name. Touch the button to change the selection.
MASTER NAME	Display the master name in the scale. Line selection/deselection is available.
NUMBER	Display the data No. of the master inside the scale.
MEMORY SPACE	Display the memory space inside the scale in kilobyte (kB).
PLU MASTER CONV.	Display the approximate value about how many items master can store in the free space.
ALL SEL.	Switch between “All items selected” / “All items unselected”.
EXEC	Initialize the selected master. The INITIALIZATION CHECK dialog appears to ask whether to initialize the master.

2.23.5 FILE SAVE / LOAD / DETAIL

The screenshot shows a software interface for the 'FILE SAVE/LOAD / DETAIL' menu. The window title bar displays 'FILE SAVE/LOAD / DETAIL' on the left and 'APR.12.2024 (FRI) 5:20PM' on the right. The main content area contains four distinct menu sections, each with a blue header and two selectable options:

- RENEW CONTROL:** Options are 'NO' (highlighted in yellow) and 'YES' (grey).
- TRAY LIMIT:** Options are 'LIMIT' (grey) and 'NON LIMIT' (highlighted in yellow).
- CHARACTERS OUT TYPE:** Options are 'CONTROL CODE NO' (grey) and 'CONTROL CODE YES' (highlighted in yellow).
- INPUT MODE:** Options are 'CHANGE' (highlighted in yellow) and 'ADDITION' (grey).

A small orange icon is visible in the top right corner of the main content area.

Menu name	Specification
RENEW CONTROL	Select whether or not to control update. NO / YES
TRAY LIMIT	Select whether or not to limit the tray. LIMIT / NO LIMIT
CHARACTERS OUT TYPE	Select the character output type. CONTROL CODE NO / CONTROL CODE YES [CONTROL CODE NO] cannot be selected.
INPUT MODE	Select the input mode. CHANGE / ADDITION

Chapter 3 Adjustment Mode

3.1 Adjustment Mode

3.1.1 Startup

- 1. Turn on the power.

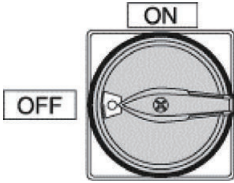

- 2. The PREPACK screen in the OPERATE mode appears.

Press  at the upper right side of the screen.

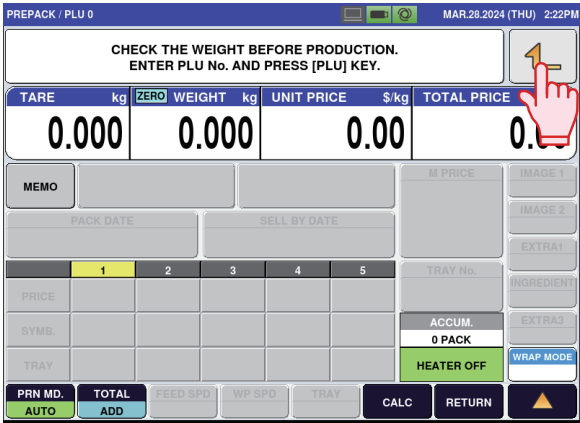

- 3. The menu appears in the OPERATE MODE.

Press the [ADJUST] button on the screen.



- 4. The User Menu screen in the Setup mode appears.

Input the password "495344" using the numerical keys, and press the [LOGIN] button on the screen.

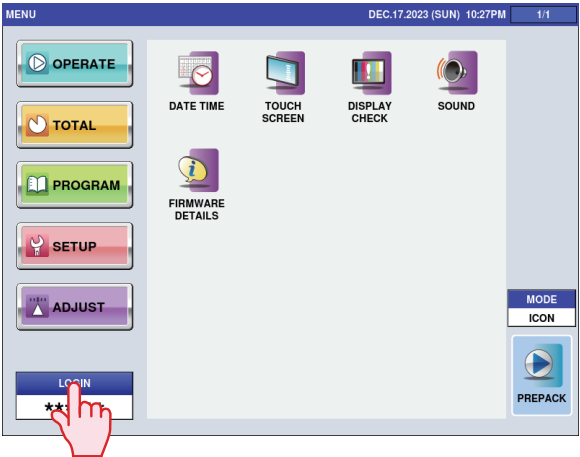

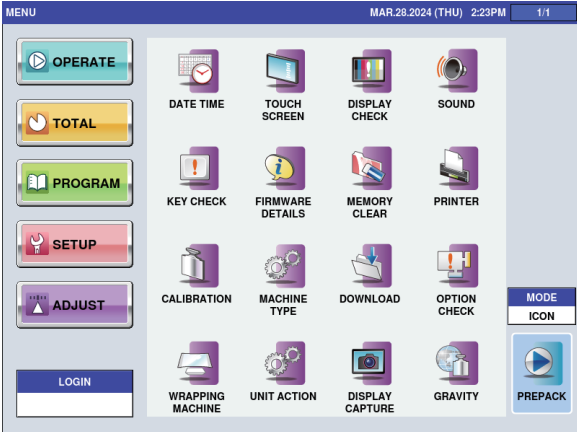

5. The User Menu screen in the Setup mode appears.

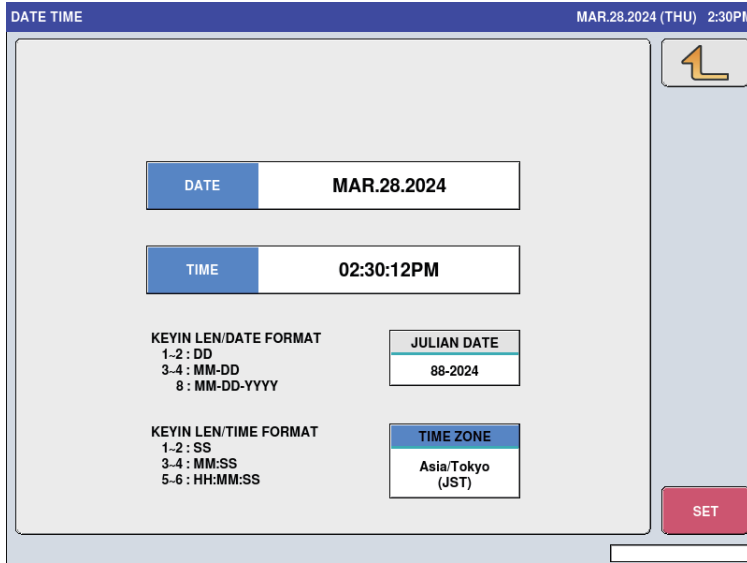

Setup Menu screen

3.2 Date Time

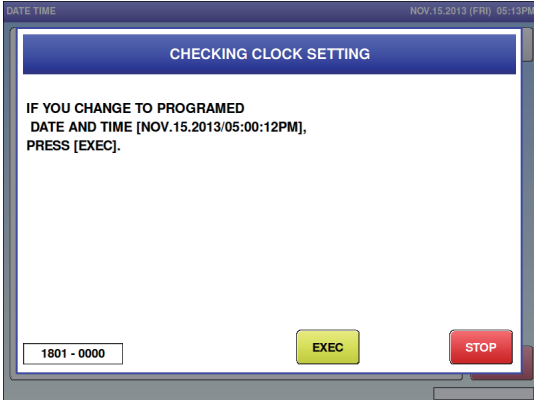

Menu name	Specification
	<p>Return to Menu. When any change is made, save the setting (with confirmation message).</p> 
DATE	<p>Enter the date conforming to KEYIN LEN/DATE FORMAT. If "21022013" is entered, "21-02-2024" is displayed. If "20" is entered, "20-02-2024" is displayed. If "2003" is entered, "20-03-2013" is displayed.</p>
TIME	<p>Enter the time conforming to KEYIN LEN/TIME FORMAT. If "00" is entered, "17:53:00" is displayed. If "2000" is entered, "17:20:00" is displayed. If "152000" is entered, "15:20:00" is displayed.</p>
JULIAN DATE	<p>Display the number of days counted from January 1.</p>

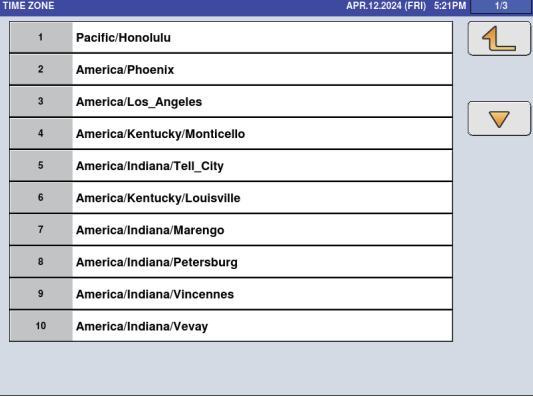
Menu name	Specification
TIME ZONE	<p>Set the time zone. When pressing this button without numeric value, the time zone list is displayed according to country setting. When pressing it with 495344 entered, the entire time zone list is displayed.</p> 
SET	<p>Set the entered date and time. The CHECKING CLOCK SETTING dialog appears to ask whether to change the date and time.</p>

3.3 Touch Screen

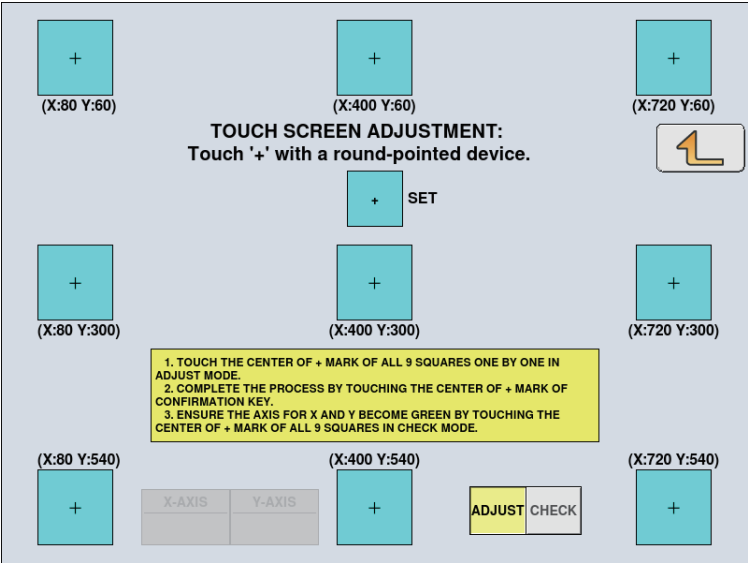

Menu name	Specification
[+]	Acquire the coordinates. The background changes to yellow when this key is pressed to acquire the coordinates, indicating that it has already been pressed.
Middle center [SET]	The touch panel is corrected based on the three acquired coordinates.
To initialize the touch screen, press the center yellow column at least six times.	

Touch panel screen forced operations

If the touch panel does not work due to extreme misalignments of the coordinates, it is not possible to enter the touch screen adjustment screen. Follow the steps below to avoid this situation.

- 1) Press the [C] (clear) key at least 11 times in a row.
- 2) The display advances to the touch panel adjustment screen, so adjust the touch panel.

3.4 Display Check

• HORIZONTAL screen

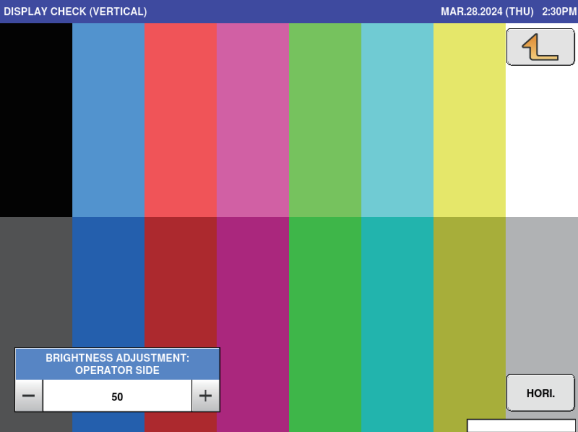

• VERTICAL screen



Menu name	Specification
BRIGHTNESS ADJUSTMENT: OPERATOR SIDE	Adjust the brightness of LED. Input range: 0 to 100
VERT. / HORI.	Switch between the vertical and horizontal screen display.

3.5 Sound

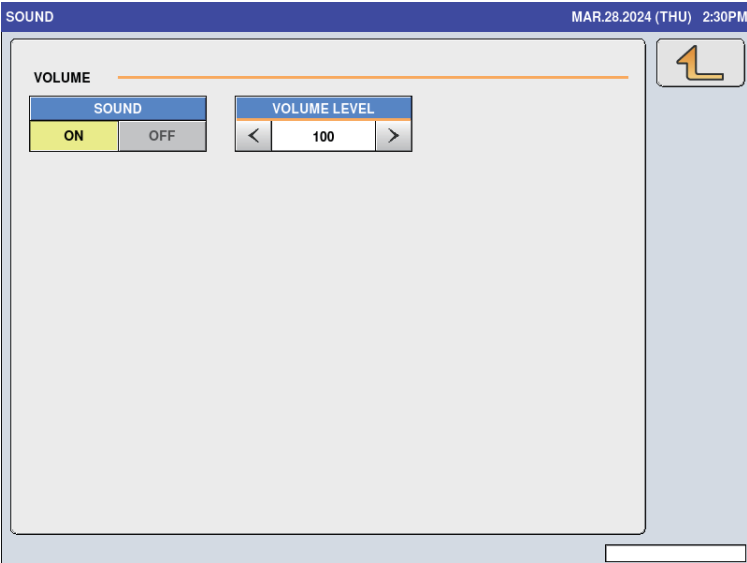

Menu name	Specification
SOUND	Switch between the sound ON and OFF.
VOLUME	Adjust the volume. Input range: 0 to 100

3.6 Key Check

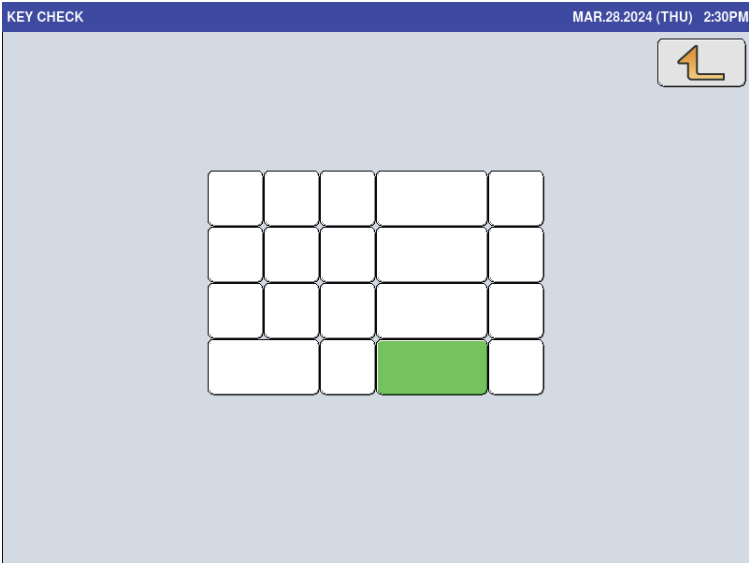

Menu name	Specification
	The touched button changes to green, showing the button is activated.

3.7 Firmware Details

FIRMWARE DETAILS		MAR.28.2024 (THU) 2:30PM	
TITLE SOFTWARE	B0813	LICENSE	
SOFTWARE	VERSION	SOFTWARE	VERSION
MAIN	B0814	WRAP APP.(BOOT)	J1183(J1106C)
SCALE DRIVER (UPDATER)	J0834(J0835)		
OS	Z3282A	PRINTER APP.	J1094D
BOOT	J1072C		
FPGA APP.	J1058C		
KEY BOARD	J0823B		
SCALE	J0776L		

Menu name	Specification
LICENSE	<p>Move to the FIRMWARE DETAILS / LICENSE screen.</p> <p>The screenshot shows a window titled 'FIRMWARE DETAILS / LICENSE' with a timestamp of 'MAR.28.2024 (THU) 2:30PM' and a page number '1/308'. The main content area contains the following text:</p> <p>NOTICE AND LICENSES FOR SOFTWARE USED IN THIS PRODUCT</p> <p>This product includes open source software("OSS") . Some OSS is subject to the GNU General Public License ("GPL") or GNU Lesser General Public License ("LGPL"). These license grant customers the right to modify and redistribute the source code of the software in accordance with the GPL or the LGPL.</p> <p>OSS List</p> <ul style="list-style-type: none"> Linux Kernel FreeType Xorg Mozc <p>Navigation icons for home and back are visible on the right side of the screen.</p>

3.8 Memory Clear

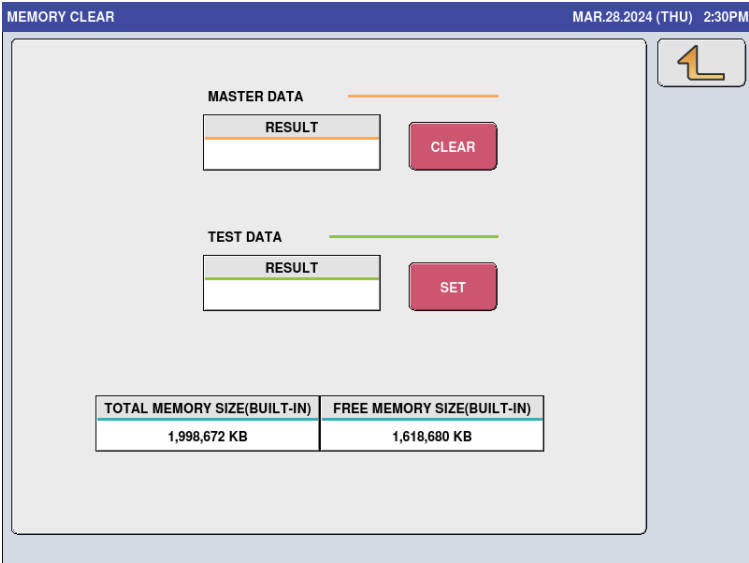

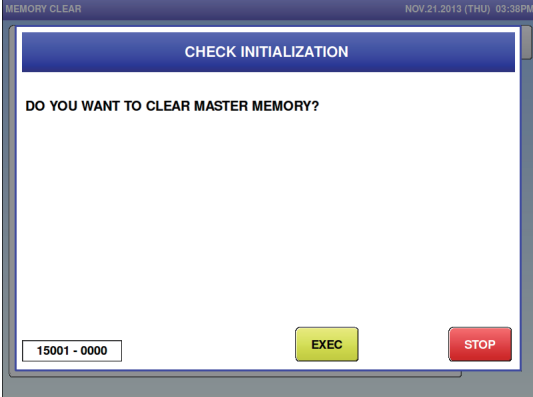
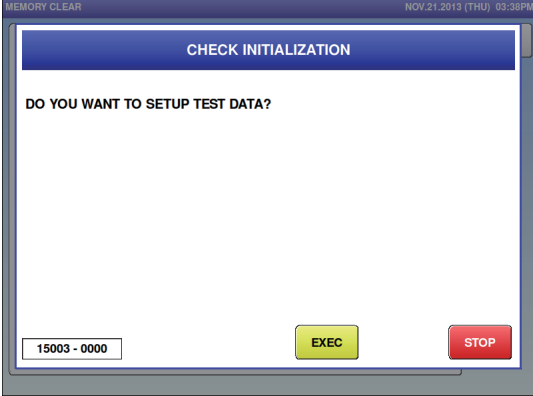
Menu name	Specification
<p>MASTER DATA CLEAR</p>	<p>Clear all DB and initialize the system master. The CHECK INITIALIZATION dialog (memory clear) appears to ask whether to clear the memory.</p>  <p>The screenshot shows a dialog box titled 'CHECK INITIALIZATION' with the question 'DO YOU WANT TO CLEAR MASTER MEMORY?'. At the bottom, there is a text field containing '15001 - 0000', a green 'EXEC' button, and a red 'STOP' button.</p>
<p>TEST DATA SET</p>	<p>Set the initial data and initialize the system master. The CHECK INITIALIZATION dialog (test data setting) appears to ask whether to set the test data. For Oceanian model, the password "951753" should be entered to set the test data.</p>  <p>The screenshot shows a dialog box titled 'CHECK INITIALIZATION' with the question 'DO YOU WANT TO SETUP TEST DATA?'. At the bottom, there is a text field containing '15003 - 0000', a green 'EXEC' button, and a red 'STOP' button.</p>

Menu name	Specification
MASTER DATA RESULT	Clear the master data and display the result. OK / ERROR
TEST DATA RESULT	Initialize the system data and display the result. OK / ERROR
TOTAL MEMORY SIZE (BUILT-IN)	Display the built-in memory size in kilobyte (kB).
FREE MEMORY SIZE (BUILT-IN)	Display the free memory size in kilobyte (kB).
TOTAL MEMORY SIZE (CARD)	Display the memory size in kilobyte (kB) when the SD card is inserted. If the SD card is not inserted, the option is grayed out.
FREE MEMORY SIZE (CARD)	Display the free memory size in kilobyte (kB) when the SD card is inserted. If the SD card is not inserted, the option is grayed out.

3.9 Printer (Label equipped)

How to set the hardware for printing and label feeding is described here.

For delivery, perform the adjustment by using the labels actually in use.

To troubleshoot the failures caused by labels, use the genuine monitor labels for comparative evaluation.

3.9.1 PRINTER (HEAD)

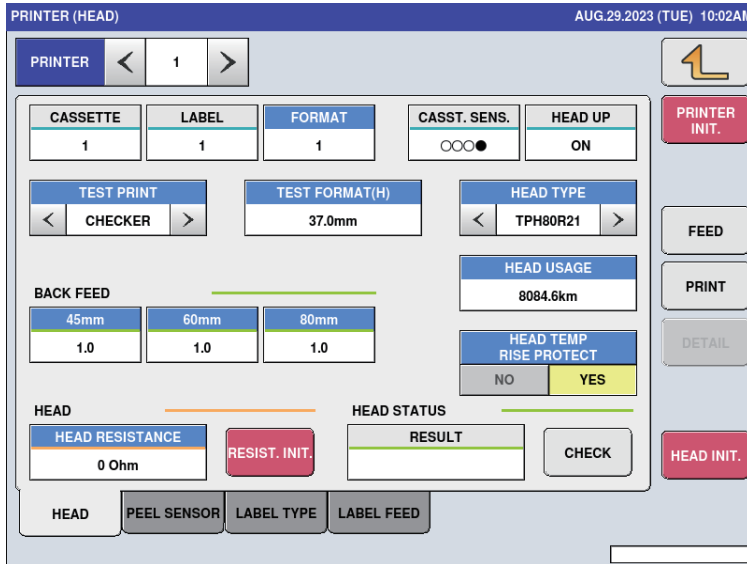

Menu name	Specification
PRINTER	Select the printer. Only connected printer is displayed.
FORMAT	Set the format No. for the test print. Input range: 0 to 999 If there is no format, nothing is printed.
TEST PRINT	Select CHECKER (checkered pattern) or NORMAL (normal pattern).
TEST FORMAT(H)	Set the height of format directly. Input range: 0 to 999
HEAD TYPE	Select the head type.
BACK FEED ADJUSTMENT	Adjust the back feed for each label length. Input range: 0 to 99
HEAD USAGE	Displays the total distance labels have been fed while printing (the head is ON). Use this as a guide until the thermal head is damaged. After replacing the thermal head, enter "0" and press this button to set the distance to "0.0 km".

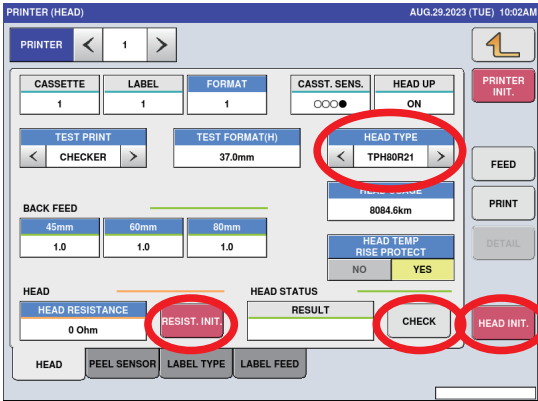
Menu name	Specification
HEAD TEMP RISE PROTECT	<p>Select whether or not to perform temperature rise protection when the head temperature exceeds 60 degrees.</p> <p>YES: During continuous printing, printing stops when the temperature reaches 60 or higher.</p> <p>NO: During continuous printing, printing does not stop even when the temperature reaches 60 or higher.</p> <p>With the label issuing capacity of the machine, the temperature will not reach 60°C.</p>
HEAD RESISTANCE	<p>Displays the set head resistance value.</p> <p>The numerical value corresponding to the rank acquired in "RESIST.INIT." is set. It can also be set by pressing this button after entering the resistance value listed on the head.</p>
RESIST.INIT.	<p>Obtain the resistance value of the head.</p> <p>This machine acquires the rank number of the thermal head and sets the resistance value of the rank table.</p>
PRINTER INIT.	<p>Initialize the printer.</p> <p>The CHECK INITIALIZATION dialog (printer initialization) appears to ask whether to initialize the printer.</p> <p>Other tabs also have the same function.</p>
PRINT	<p>Execute the print.</p> <p>Other tabs also have the same function.</p>
FEED	<p>Execute the feed.</p> <p>Other tabs also have the same function.</p>
HEAD INIT.	<p>Initialize the thermal head.</p> <p>The CHECK INITIALIZATION dialog (head initialization) appears to ask whether to initialize the thermal head.</p> <p>Follow the procedure below.</p> <ol style="list-style-type: none"> ① Press [HEAD INIT.]. ② On the confirmation screen, press [EXEC]. ③ Check HEAD TYPE on the printer to set the head type to be mounted. ④ Press [RESIST.INIT.] in HEAD RESISTANCE. ⑤ Press [CHECK] in HEAD STATUS CHECK to check the head availability. 

3.9.2 PRINTER (PEEL SENSOR)

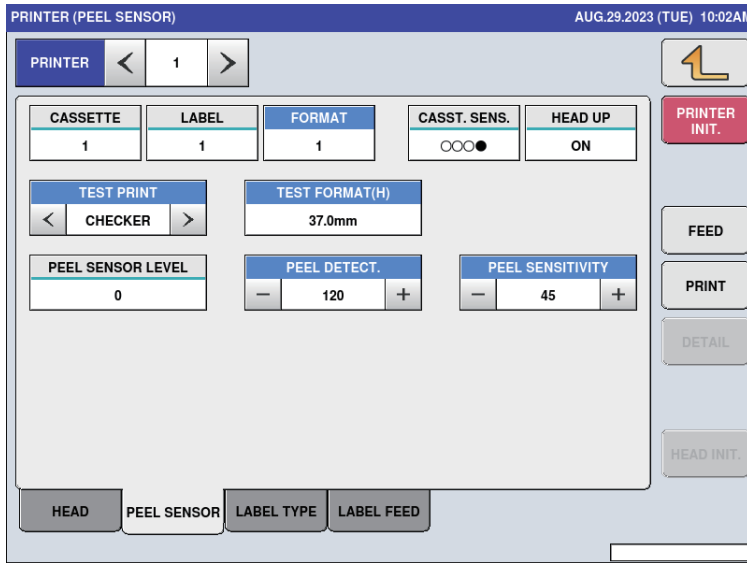

Menu name	Specification
PEEL DETECT.	If the peel sensor value is greater than the set peeling sensor threshold, it is determined that there is no label, and If the peeling sensor value is smaller than the peeling sensor value, it is determined that there is a (Initial data: 120) Input range: 0 to 255
PEEL SENSITIVITY	The amplification level of the peeling sensor sensitivity can be set. (Initial data: 45) Increasing the sensitivity of the peeling sensor amplifies the output signal of the peeling sensor. Input range: 0 to 255
PEEL SENSOR LEVEL	Display the output value of peel sensor.
Set the threshold depending on the PEEL SENSOR LEVEL at the time the backing paper remains on the sensor or not. (e.g. If the value at the time the backing paper remains is 180 and if the value at the time the backing paper does not remain is 80, the threshold is set to about 150.)	

3.9.3 PRINTER (LABEL TYPE)

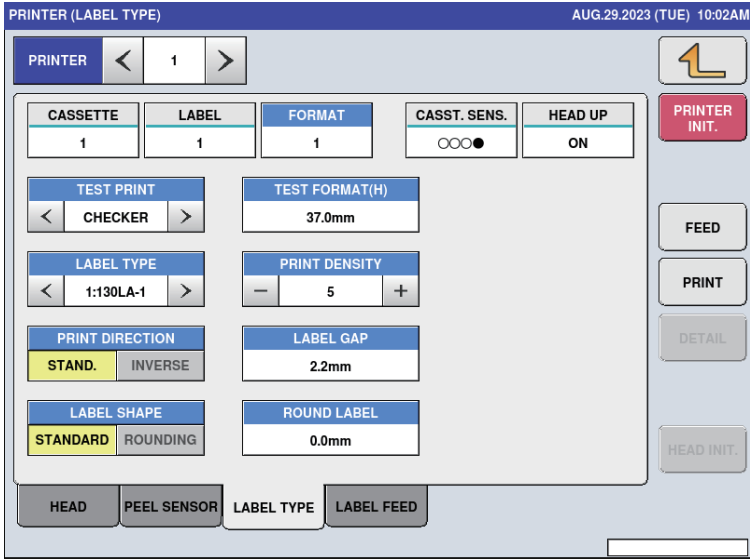

Menu name	Specification
LABEL TYPE	Select the label type. 0: RECEIPT / 1:130LA-1 / 3:150LA-1
PRINT DENSITY	Adjust the print density.(Initial data: 5) Input range: 0 to 9
PRINT DIRECTION	Select the print direction. STAND. / INVERSE
LABEL GAP	Set the “Interval between labels” of the label roll set to the printer. Input range: 0 to 99.9
LABEL SHAPE	Select the label shape. STANDARD / ROUNDING
ROUND LABEL	For labels including elliptical labels, the upper side of a label (end face in a vertical direction) and the position where the label sensor detects the end face of the label. Input range: 0 to 999

3.9.4 PRINTER (LABEL FEED)

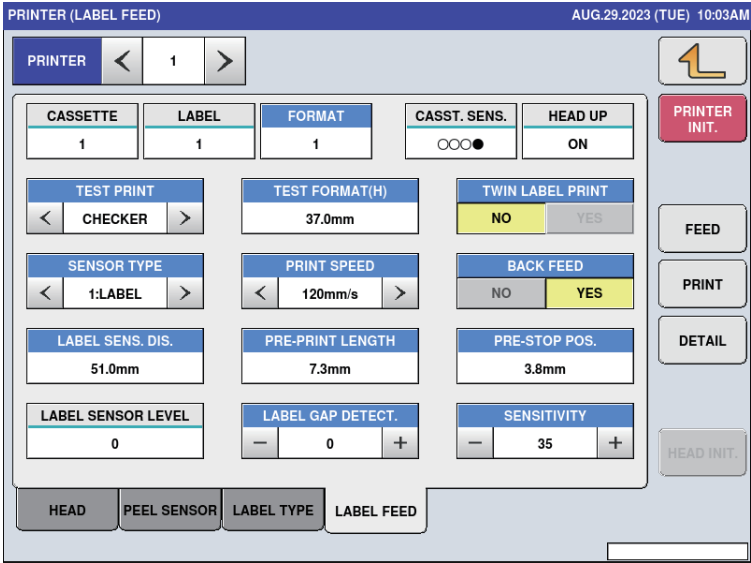

Menu name	Specification
<p>DETAIL</p>	<p>Transfer to the label sensor details screen.</p> <p>When the [DETAIL SET] button is pressed (during change amount control)</p> <div data-bbox="501 1088 995 1456"> </div> <p>Press the [FEED] key and check the sensor value (output value).</p> <p>Set the value of "Label sensor sensitivity" with the gap peak value around 200 as a guide.</p> <p>If the output of the label part has changed by 40 or more (judgment is 60), detection is made by the threshold.</p> <div data-bbox="1062 1357 1257 1525"> </div>
	<p>When the [DETAIL SET] button is pressed (during threshold control)</p> <div data-bbox="501 1615 995 1982"> </div> <p>A red line appears when "Label sensor threshold" is set to anything other than "0". This value becomes the criterion.</p> <p>Set a value at 2/3 between the high output of the label part and the output of the label gap part.</p> <div data-bbox="1038 1901 1222 2056"> </div>

Menu name	Specification
TWIN LABEL PRINT	Set whether to perform twin label print in the test print. NO: label feed is controlled in pricing in DP mode. YES: label feed controlled on pasting label by the labelling machine. Set this field to YES for this machine.
SENSOR TYPE	Set the sensor type. 0: NONE / 1: LABEL / 2: MARK Set this field to 1: LABEL for this machine.
PRINT SPEED	Set the print speed. 120 mm/s Cannot be changed on this machine.
BACK FEED	Select whether or not to set the back feed. Set this field to YES for this machine.
LABEL SENS. DIS.	Set the label sensor distance. Set the distance between the label sensor and the label peeling shaft (the tip of the label outlet). Changing this distance changes the printing position in the label feed direction. Perform a test printing of the checkered pattern and enter a value so that dimensions of the ruled lines above the address and store name and the bottom short side of the label will become the same as the advanced feed amount. Input range: 0 to 99.9 (Initial data: 51.0)
PRE-PRINT LENGTH	Set the distance to which the label should be fed from the front edge of the head when the label is issued in DP mode. For this machine, the distance from the center of the print roller to the tip of the peeling shaft is 9.5 mm. Set the value obtained by subtracting the label gap dimension from this 9.5 mm. PRE-PRINT LENGTH = 9.5mm - Input range: 0 to 99.9
PRE-STOP POS.	When printing the second line, feeding of the printed label is stopped and resumed again immediately when the pasting machine absorbs the label. This option sets the label feeding distance to the position from the edge of head front at the temporal stop of the label feeding. Input range: 0 to 99.9
LABEL GAP DETECT.	Set the label sensor threshold. Enter the value you see in DETAIL. Input range: 0 to 255
SENSITIVITY	Set the label sensor sensitivity. Enter the sensitivity setting in DETAIL. Input range: 0 to 255 (Do not set to a value exceeding 200.)

3.10 Printer (Linerless)

How to set the hardware for printing and label feeding is described here.

For delivery, perform the adjustment by using the labels actually in use.

To troubleshoot the failures caused by labels, use the genuine monitor labels for comparative evaluation.

3.10.1 PRINTER (HEAD)

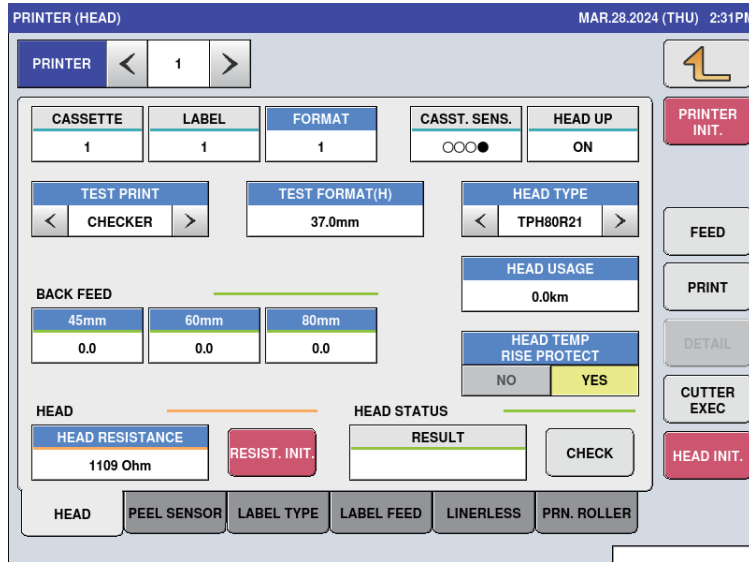

Menu name	Specification
PRINTER	Select the printer. Only connected printer is displayed.
FORMAT	Set the format No. for the test print. Input range: 0 to 999 If there is no format, nothing is printed.
TEST PRINT	Select CHECKER (checkered pattern) or NORMAL (normal pattern).
TEST FORMAT(H)	Set the height of format directly. Input range: 0 to 999
HEAD TYPE	Select the head type.
BACK FEED ADJUSTMENT	Adjust the back feed for each label length. Input range: 0 to 99
HEAD USAGE	Displays the total distance labels have been fed while printing (the head is ON). Use this as a guide until the thermal head is damaged. After replacing the thermal head, enter "0" and press this button to set the distance to "0.0 km".

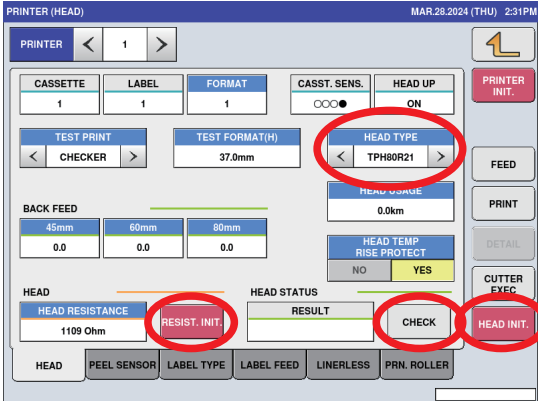
Menu name	Specification
HEAD TEMP RISE PROTECT	<p>Select whether or not to perform temperature rise protection when the head temperature exceeds 60 degrees.</p> <p>YES: During continuous printing, printing stops when the temperature reaches 60 or higher.</p> <p>NO: During continuous printing, printing does not stop even when the temperature reaches 60 or higher.</p> <p>With the label issuing capacity of the machine, the temperature will not reach 60°C.</p>
HEAD RESISTANCE	<p>Displays the set head resistance value.</p> <p>The numerical value corresponding to the rank acquired in "RESIST.INIT." is set. It can also be set by pressing this button after entering the resistance value listed on the head.</p>
RESIST.INIT.	<p>Obtain the resistance value of the head.</p> <p>This machine acquires the rank number of the thermal head and sets the resistance value of the rank table.</p>
PRINTER INIT.	<p>Initialize the printer.</p> <p>The CHECK INITIALIZATION dialog (printer initialization) appears to ask whether to initialize the printer.</p> <p>Other tabs also have the same function.</p>
PRINT	<p>Execute the print.</p> <p>Other tabs also have the same function.</p>
FEED	<p>Execute the feed. The cutter unit operates one cycle.</p> <p>Other tabs also have the same function.</p>
HEAD INIT.	<p>Initialize the thermal head.</p> <p>The CHECK INITIALIZATION dialog (head initialization) appears to ask whether to initialize the thermal head.</p> <p>Follow the procedure below.</p> <ol style="list-style-type: none"> ① Press [HEAD INIT.]. ② On the confirmation screen, press [EXEC]. ③ Check HEAD TYPE on the printer to set the head type to be mounted. ④ Press [RESIST.INIT.] in HEAD RESISTANCE. ⑤ Press [CHECK] in HEAD STATUS CHECK to check the head availability.  <p>The screenshot shows the printer's adjustment menu with the following elements circled in red:</p> <ul style="list-style-type: none"> HEAD TYPE: A button labeled 'TPH80R21' in the 'HEAD TYPE' section. RESIST. INIT.: A button labeled 'RESIST. INIT.' in the 'HEAD RESISTANCE' section. CHECK: A button labeled 'CHECK' in the 'HEAD STATUS' section. HEAD INIT.: A button labeled 'HEAD INIT.' in the 'HEAD STATUS' section.

3.10.2 PRINTER (PEEL SENSOR)

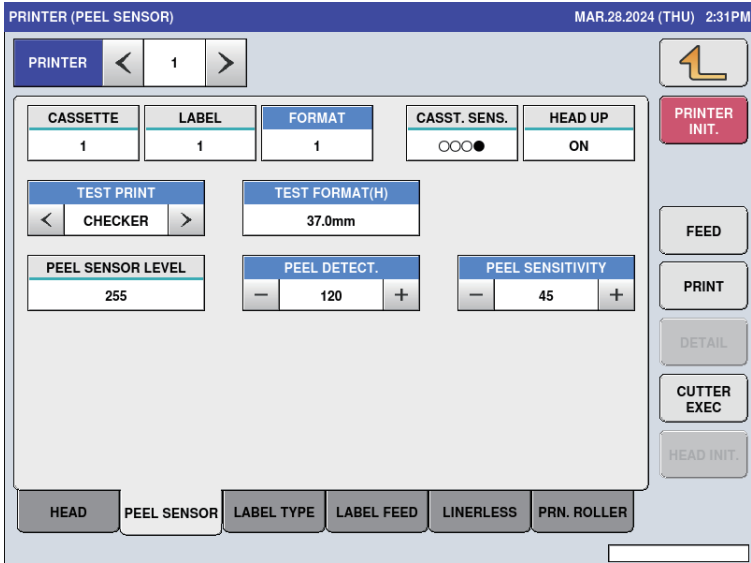

Menu name	Specification
PEEL DETECT.	If the peel sensor value is greater than the set peeling sensor threshold, it is determined that there is no label, and If the peeling sensor value is smaller than the peeling sensor value, it is determined that there is a (Initial data: 120) Input range: 0 to 255
PEEL SENSITIVITY	The amplification level of the peeling sensor sensitivity can be set. (Initial data: 45) Increasing the sensitivity of the peeling sensor amplifies the output signal of the peeling sensor. Input range: 0 to 255
PEEL SENSOR LEVEL	Display the output value of peel sensor.
Set the threshold depending on the PEEL SENSOR LEVEL at the time the backing paper remains on the sensor or not. (e.g. If the value at the time the backing paper remains is 180 and if the value at the time the backing paper does not remain is 80, the threshold is set to about 150.)	

3.10.3 PRINTER (LABEL TYPE)

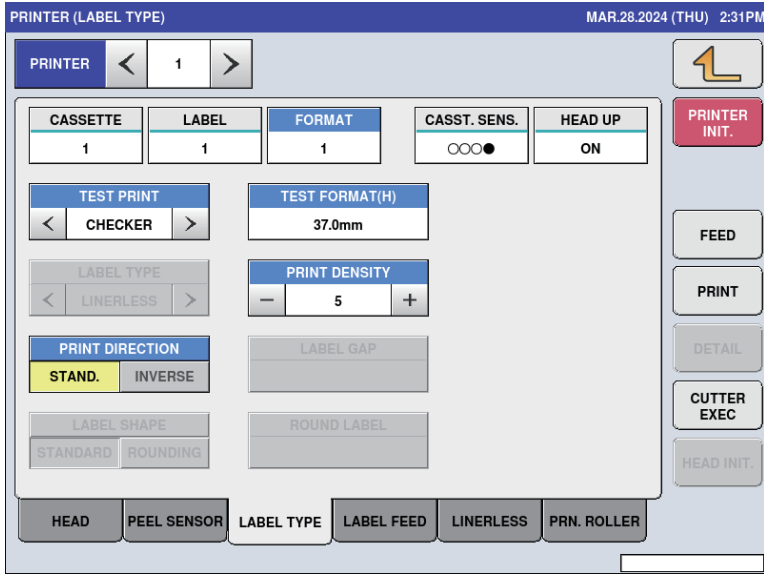

Menu name	Specification
PRINT DENSITY	Adjust the print density.(Initial data: 5) Input range: 0 to 9
PRINT DIRECTION	Select the print direction. STAND. / INVERSE

3.10.4 PRINTER (LABEL FEED)

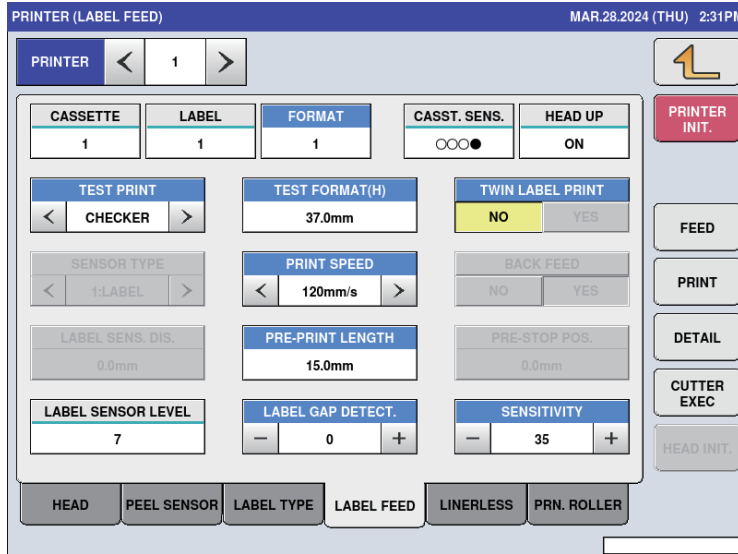

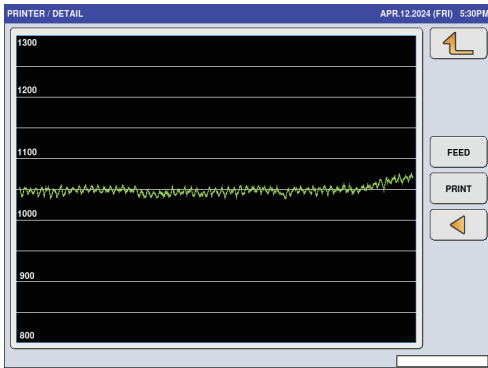
Menu name	Specification
DETAIL	Transfer to the label sensor details screen. 
TWIN LABEL PRINT	Set whether to perform twin label print in the test print. NO: label feed is controlled in pricing in DP mode. YES: label feed controlled on pasting label by the labelling machine. Set this field to YES for this machine.
PRINT SPEED	Set the print speed. 100 mm/s / 120 mm/s / 150 mm/s Set this field to 120 mm/s for this machine.
PRE-PRINT LENGTH	PRE-PRINT LENGTH = 9.5mm - Input range: 0 to 99.9 Initial data is fixed to 15.0.
LABEL GAP DETECT.	Set the label sensor threshold. Enter the value you see in DETAIL. Input range: 0 to 255
SENSITIVITY	Set the label sensor sensitivity. Enter the sensitivity setting in DETAIL. Input range: 0 to 255

3.10.5 PRINTER (LINERLESS)

PRINTER (LINERLESS) MAR.28.2024 (THU) 2:31PM

PRINTER < 1 >

CASSETTE 1 LABEL 1 FORMAT 1 CUTTER ORIGIN ON CUTTER COVER CLOSE

TEST PRINT CHECKER TEST FORMAT(H) 37.0mm TWIN LABEL PRINT NO YES

CUTTING POS. 23.0mm VACUUM POS. 16.6mm PASTE FEED LEN. 4.0mm

PRINT GUIDE LINE NO YES USE CUTTER SENS. NO YES CUTTER USE NO YES

CUTTER UNIT REPLACEMENT MSG. OFF ON REP. TIMES 0 NUMBER OF CUT TIMES RESULT 295 CLEAR

HEAD PEEL SENSOR LABEL TYPE LABEL FEED LINERLESS PRN. ROLLER

PRINTER INIT. FEED PRINT DETAIL CUTTER EXEC HEAD INIT.

Menu name	Specification
TWIN LABEL PRINT	Set whether to perform twin label print in the test print. NO: label feed is controlled in pricing in DP mode. YES: label feed controlled on pasting label by the labelling machine. Set this field to YES for this machine.
CUTTING POS.	Set the distance from the home position to the cutter. Input range: 1 to 999 Note that values less than the lead stop amount cannot be entered. Place in the position that the print guideline to be cut.
PRINT GUIDE LINE	Set whether or not to print a dashed line at the top of the label of a checkered pattern printing label. NO: Do not print YES: Print Note that this setting is valid only for the printer screen.
USE CUTTER SENS.	Set whether or not to enable the cutter cover sensor. NO: Disable YES: Enable Note that this setting is valid only for the printer screen.
CUTTER USE	Set whether or not to use the cutter to issue labels. NO: Do not use YES: Use Note that this setting is valid only for the printer screen.
REPLACEMENT MSG.	Set whether or not to display the cutter replacement message when power is turned on. NO: Do not display message YES: Display message
REP. TIMES	Valid when REPLACEMENT MSG. is "ON". Set the number of cutting times to display the cutter replacement message. Settable value: 0 to 2000000 (Initial value: 0) When the set value is "0", the number of cutting times for cutter replacement is not displayed.
RESULT	Display the current number of times the cutter has been used.
CLEAR	Touch to reset the number of times the cutter has been used.

3.10.6 PRINTER(PRN. ROLLER)

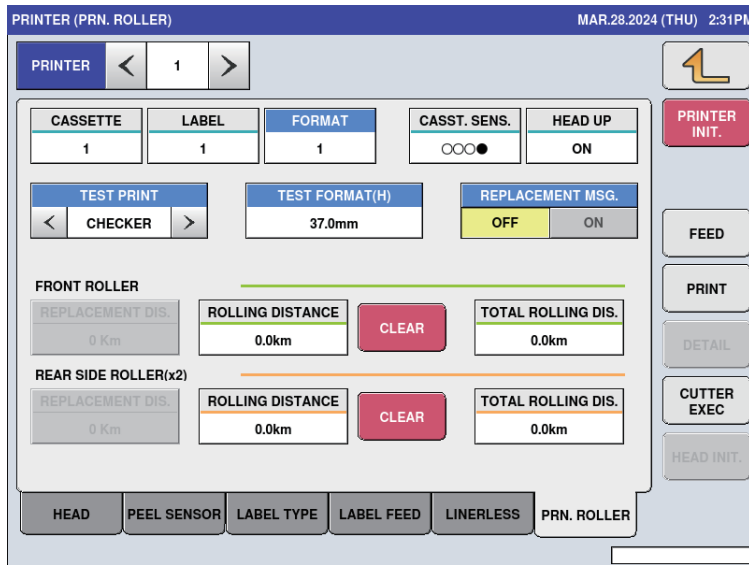

Menu name	Specification
REPLACEMENT MSG.	Set to display platen roller replacement message when power is turned on. NO: Do not display message YES: Display message
REPLACEMENT DIS.	Valid when REPLACEMENT MSG. is "ON". Set the distance traveled to display the platen roller (FRONT: Suction unit) replacement message. Settable value: 0 to 99 (Initial value: 0) If "0", no message is displayed.
ROLLING DISTANCE	Display the travel distance of each roller.
CLEAR	Touch to reset the roller travel distance.
TOTAL ROLLING DIS.	Display the cumulative travel distance of each roller.

3.11 Calibration

CALIBRATION MAR.28.2024 (THU) 2:31PM

SETTING

CAPACITY	RANGE	SPAN A/D	GRAVITATIONAL ACC.
< 15kg >	SINGLE MULTI	75000	9.7970

SCALE DATA

A/D	CELL VOLTAGE	STATUS
20008		0100 0001

WGT. CONVERTED

WEIGHT A/D	WEIGHT	DATA DISPLAY
0	0.000 kg	WEIGHT VOLTAGE

OTHERS

1083 2004 01003 003000 004001
DIP SW : 00000000

Capacity 0-6kg x 0.002kg 6-15kg x 0.005kg

Menu name	Specification
CAPACITY	Set the capacity of the scale. 6000g / 6kg / 15kg / 30kg / 30lb
RANGE	Select the range. The range to be selected is limited depending on the capacity.
GRAVITATIONAL ACC.	Set the gravitational acceleration. Input range: 97799 to 98300
DATA DISPLAY	Select the A/D or cell voltage display.
INITIAL	Initialize the scale.
ZERO	Adjust the current scale status to zero.
SPAN	Set the current scale status to CAPACITY according to the CAPACITY setting.
+	Add span value.
-	Deduct span value.

3.11.1 Procedure for adjusting scale (span)

1. Press [INITIAL] key to initialize the A/D data.
2. Press [ZERO] key to adjust the zero point.
3. Place the weight on scale and press [SPAN] key.
[+/-] key for little adjustment, if necessary.
4. Remove the weight and the platter from the scale.
5. Push the Memory switch (SW2 on P-1111*~*) to memorize the A/D data.
6. Seal off the memory switch again.

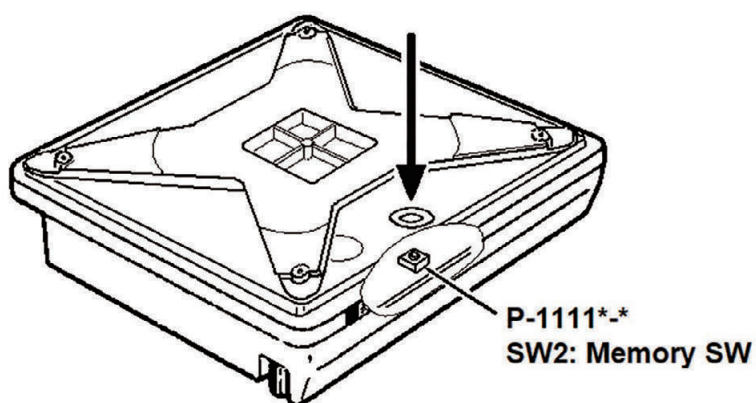

3.12 Machine Type

3.12.1 MACHINE TYPE



Menu name	Specification
TABLETOP	Judge as the tabletop type, move to the [MACHINE TYPE / DETAIL] screen. Only this option is available.

3.12.2 MACHINE TYPE / DETAIL

Menu name	Specification
WM PRODUCT ID	Set the product ID in seven digits.
CENTERING	Not used.
TRAY DETECTION	Not used.
CHANGE FILM	Not used.
VARIATION	Select and set the model variation. L: EU specification LL: US specification
NON-FILM ERROR	Not used.
FILM SET POS. SEL.	Not used.
OUTSIDE PRINTER	Select and set whether to connect the external printer.
POP PRINTER CONNECT	Not used.
PRINTER 1 POS. SEL.	Not used.
SET	Save the setting (with confirmation message).
STRUCURE	Display the configuration selected by the previous screen [MACHINE TYPE].
STATUS	Display the communication status with the wrapper.
PRINTER 1 CONNECTION	Display the communication status with Printer No.1.

3.12.3 MACHINE TYPE / PRINTER

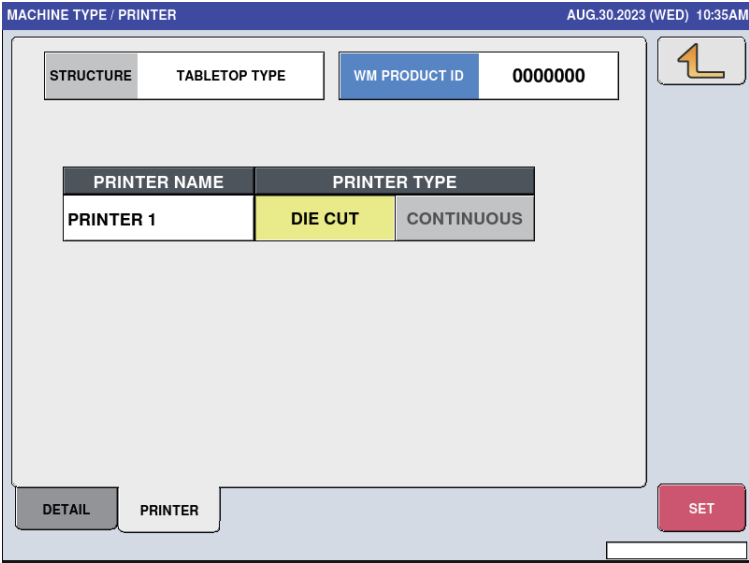

Menu name	Specification
WM PRODUCT ID	Set the product ID in seven digits.
PRINTER TYPE	Select the printer type. DIE CUT (with label) / CONTINUOUS (linerless)
SET	Save the setting (with confirmation message).

3.13 Download

3.13.1 DOWNLOAD (MAIN)

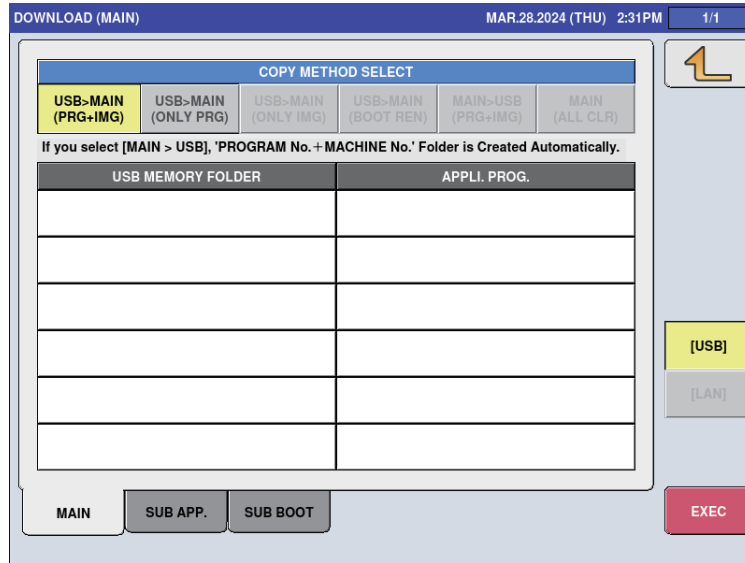

Menu name	Specification
COPY METHOD SELECT	When “USB>MAIN (PRG+IMG)” is selected, the program and the image data of the selected USB memory folder are downloaded. When “USB>MAIN (ONLY PRG)” is selected, only the program of the selected USB memory folder is downloaded. The image data is not downloaded.
USB MEMORY FOLDER	Touch this button to switch the selection.
APPLI. PROG.	Touch this button to switch the selection.
EXEC	Download the selected program. The CHECK EXECUTION OF MAIN PROGRAM DOWNLOAD dialog appears to ask whether to download the program.

3.13.2 DOWNLOAD (SUB APP.)

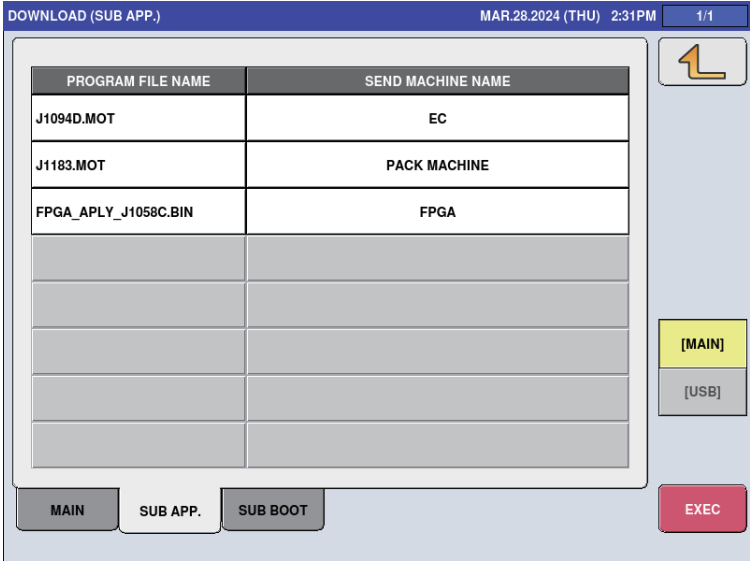

Menu name	Specification
PROGRAM FILE NAME	Touch this button to switch the selections.
SEND MACHINE NAME	Touch this button to switch the selections.
MAIN/USB	Select where the program is downloaded from. MAIN / USB
EXEC	Download the selected program. The CHECK FOR EXECUTION OF DEVICE MACHINE PROGRAM dialog appears to ask whether to download the program.

3.13.3 DOWNLOAD (SUB BOOT)

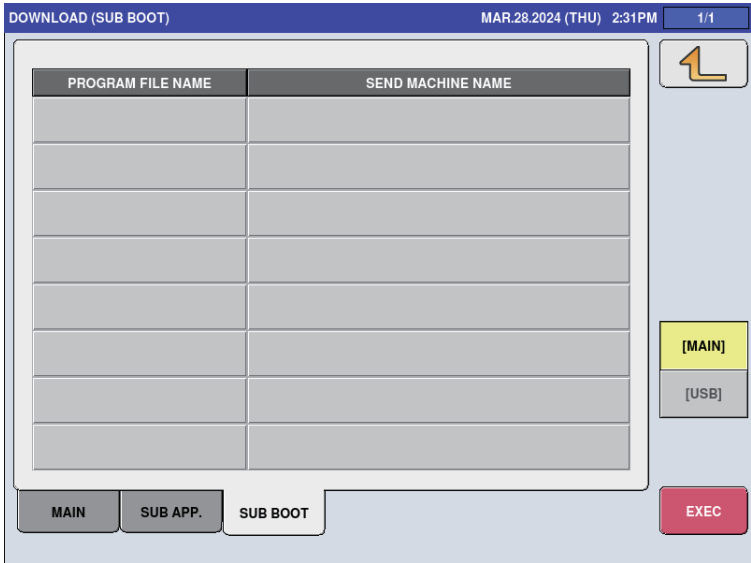

Menu name	Specification
PROGRAM FILE NAME	Touch this button to switch the selections.
SEND MACHINE NAME	Touch this button to switch the selections.
MAIN/USB	Select where the program is downloaded from. MAIN / USB
EXEC	Download the selected program. The CHECK FOR EXECUTION OF DEVICE MACHINE PROGRAM dialog appears to ask whether to download the program.

3.14 Option Checks

3.14.1 OPTION CHECK (SCANNER)

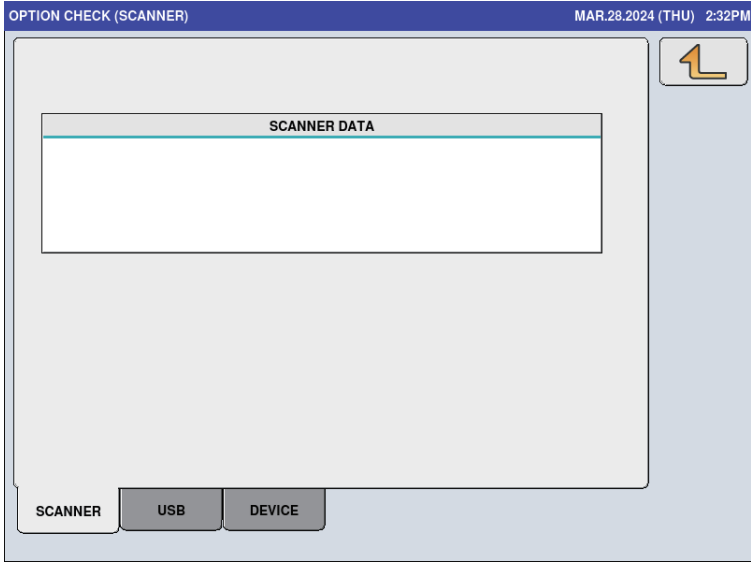

Menu name	Specification
SCANNER DATA	Display the scanned data.

3.14.2 OPTION CHECK (USB)

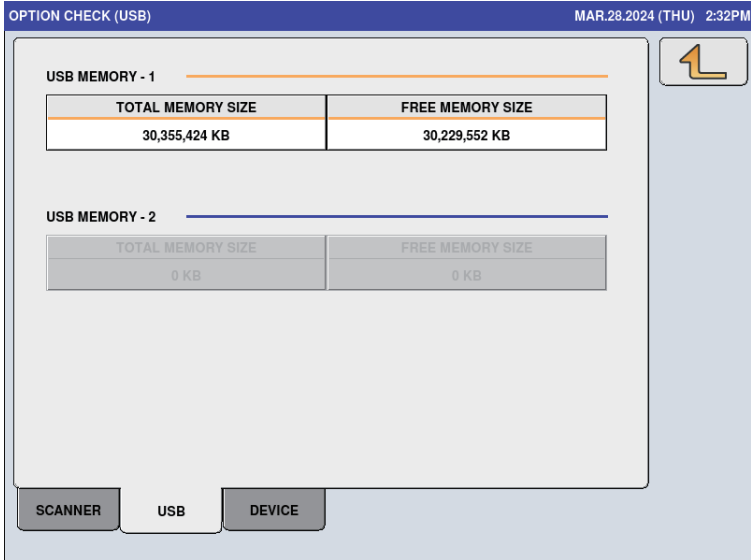

Menu name	Specification
USB MEMORY -1	Display the information of connected USB memory.
USB MEMORY -2	Display the information of connected USB memory.

3.14.3 OPTION CHECK (DEVICE)

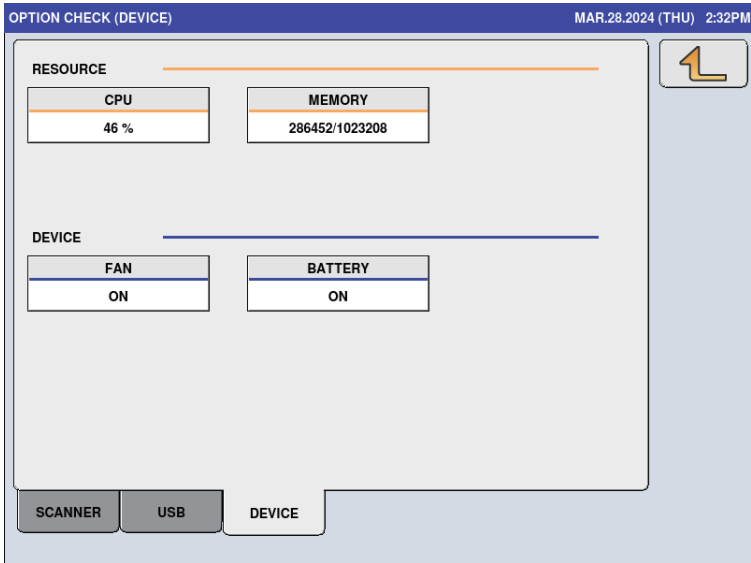

Menu name	Specification
CPU	Display the CPU use rate.
MEMORY	Display the use size and the total size of the internal memory.
FAN	Display the rotation count of the CPU fan. Unit: internal count
BATTERY	Display the battery voltage. Unit: internal AD value

3.15 Wrapping Machine

3.15.1 WRAPPING MACHINE (FILM)

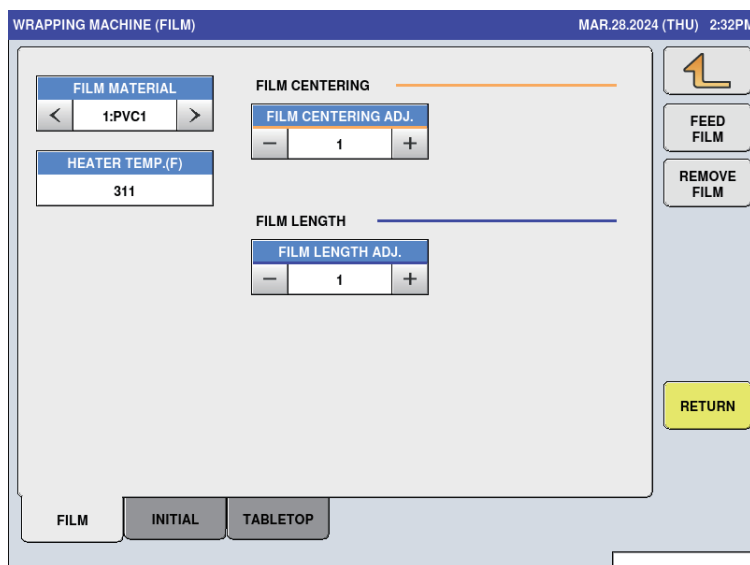

Menu name	Specification
RETURN	Return to the original position.
FILM MATERIAL	Select the material of the film used by the machine from 1: PVC1 / 2: POLY1 Set the material by entering a set number. Input range: 1 to 2
FILM CENTERING ADJ.	When feeding the film, adjust the stop position of the film to be fed. Positive direction: Move to the right (film feed direction) Negative direction: Move to the left. Press [+] or [-] without entering a numeric value ... Adjust by 1 to the positive or negative side. Press [+] or [-] after entering a numeric value ... Adjust the entered value to the positive or negative side Press any key other than [+] and [-] after entering a numeric value ... Adjust the entered value to the positive side. Input range: -99 to 99
HEATER TEMP	Set the temperature of the film welding heater. Setup range: 80 to 170°C or 176 to 339 °F
FILM LENGTH ADJ.	Adjust the length of the film when feeding the film. Input range: -99 to 99

3.15.2 WRAPPNG MACHINE (INITIAL)

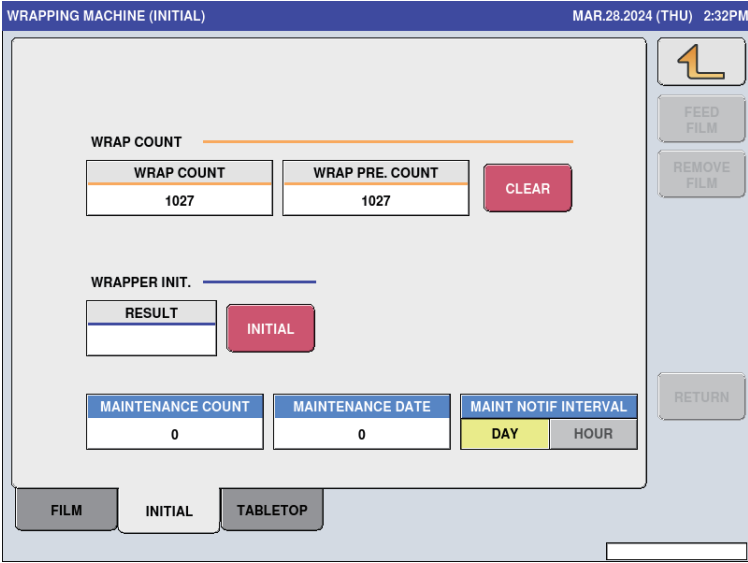

Menu name	Specification
(WRAP COUNT) CLEAR	Clear the WRAP COUNT. The WRAP PRE. COUNT is cleared by entering 495344 + CLEAR.
(WRAPPER INIT.) INITIAL	Initialize the wrapping machine. After the machine is initialized, it is necessary to set up the wrapping machine adjustment data again.
MAINTENANCE COUNT	Set the number of wrapping times to notify maintenance. Setting range: 0 to 9999999 (0: disable)
MAINTENANCE DATE	Set the date when notify maintenance. Setting range: 0 to actual YYYYMMDD (0: disable)
MAINT. NOTIF. INTERVAL	Select the interval for maintenance notifications. DAY (once a day) / HOUR (once an hour)

3.15.3 WRAPPING MACHINE (TABLETOP)

Menu name	Specification
RETURN	Return to the original position.
FILM TEMPERATURE	Select when using temperature sensor.
LOWER LIMIT	Set the lower limit of the temperature.
FILM SENSOR	Select when using the film sensor. CHECK: Specifies if the film existence should be detected for film feeding. DETECTION TIMEOUT: Specifies a time to determine that there is no film detected. MEASURED VALUE: Displays the actual time of film detection.
DETECTION TIMEOUT	Set the film transport check time. Set the check time for film transport. If the sensor cannot detect the film within the set time from the start of film transport, an error message is displayed. Valid when CHECK (FILM SENSOR) is set to "YES".

3.16 Unit Action

3.16.1 UNIT ACTION (WRAP)

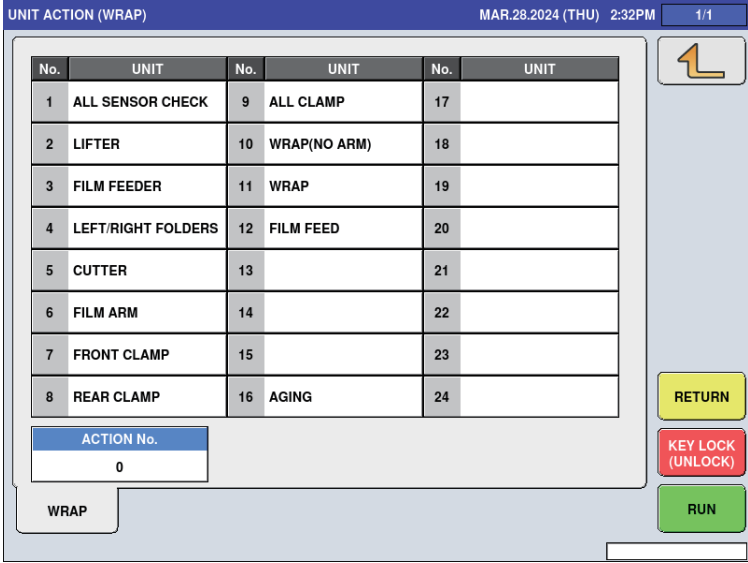

Menu name	Specification
RETURN	Return to the original position.
KEY LOCK	Prohibit/release the execution of testing operation. In the LOCK state, only stopping is permitted.
RUN	Operate the unit of the selected number. (If this item is not selected or number zero is selected, operation is stopped.)
ACTION No.	Select a unit to operate. Specify a set number. The numbers on the unit list can be specified.
UNIT	Select a unit to operate.

3.17 Display Capture

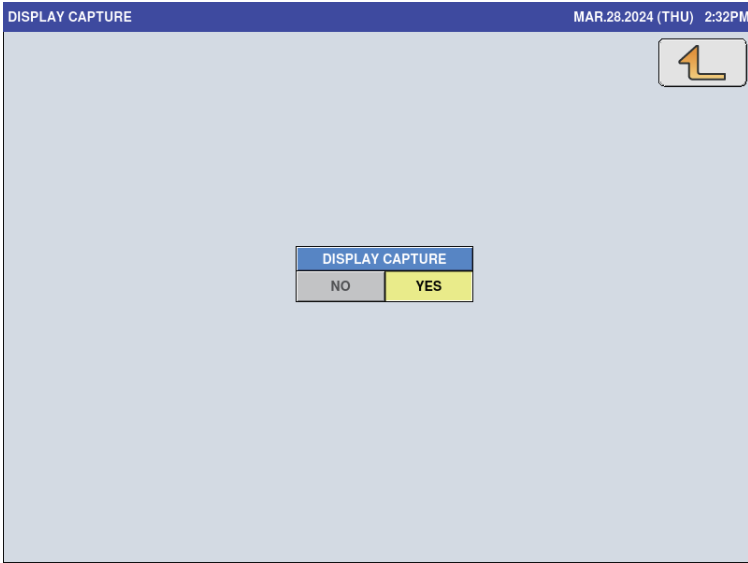

Menu name	Specification
DISPLAY CAPTURE	<p>Select display capturing. At power ON, [NO] is selected as a default setting. Selecting [YES] displays the camera mark at the lower left side of the screen. Pressing the camera mark on each screen captures the screen, and creates the PNG file. The data is stored in the Capture folder in the USB memory. The PNG file name is created in series with the name from "000_xxxx.jpg" to "999_xxxx.jpg" (xxxx refers to the screen name). When a file already has the same name, the file is overwritten. The data is reset when the power is ON, and is created again from the name "000_xxxx.jpg".</p>

3.18 Gravity

GRAVITY				MAR.28.2024 (THU) 2:32PM	
SETTING					
CAPACITY	RANGE	SPAN A/D	GRAVITATIONAL ACC.		
15kg	MULTI	75000	9.7970		
SCALE DATA					
A/D	STATUS				
20008	0100 0001				
WGT. CONVERTED					
WEIGHT A/D	WEIGHT				
0	0.000 kg				
OTHERS					
DIP SW : 00000000					
Capacity 0-6kg x 0.002kg 6-15kg x 0.005kg					

Menu name	Specification
CAPACITY	Display the capacity.
RANGE	Display the range type.
GRAVITATIONAL ACC.	Set the gravitational acceleration. Setting range: 97799 to 98300
SPAN A/D	Display the span count.
A/D	Display the A/D count.
STATUS	Display the scale status.
WEIGHT A/D	Display the A/D count for weight conversion.
WEIGHT	Display the weight.
DIP SW	Display the DIP SW status of the scale.
ZERO	Display the zero-point adjustment.

Chapter 4 Function for Each Mode

This section describes specific functions of WM-MICRO.

For other functions, see WM-AI service manual and instruction manual.

Shown below are available functions

Mode	Function
Normal Mode	Return Process at Power ON
	How to Use Preset Keys
PROGRAM Mode	WRAP Tab Added to PLU
	Preset Keys Added
	TRAY Added to Menu
SETUP Mode	FUNCTION KEY Items Added to KEY LOCK
	Items Added to PLU OVERWRITE
	WRAP Tab Added to PLU INITIAL DATA
	Items Added to PLU UPDATE
	COUNTRY (MISC) Screen Added
	Tray Master Added to FILE SAVE / LOAD
ADJUST Mode	MEMORY CLEAR Items Added
	SUB Tab Added to DOWN LOAD
	WRAPPER Added to Menu
	UNIT TEST Added to Menu
	WM-MICRO Added to MODEL

NOTE: When switching to Service Mode, press the [Mode] button in Normal Mode. The [MENU SELECT] screen appears.

4.1 Nomal Mode

4.1.1 Return Process at Power ON

A screen appears when the power is turned on that requires confirmation for the return process.

1. A screen appears when the power is turned on that requires confirmation for the return process of each drive unit.

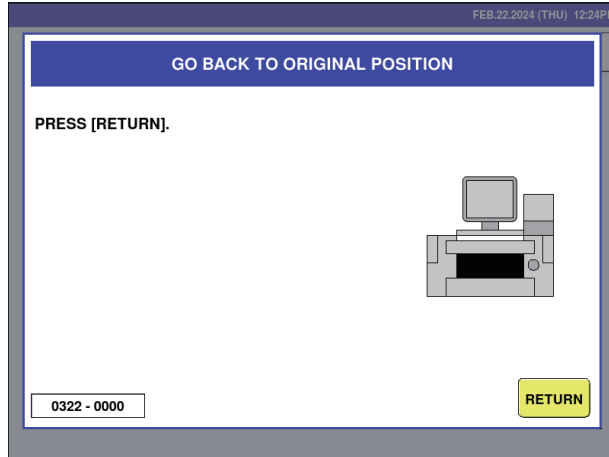

2. Touch the [RETURN] button temporarily displays a screen as shown below.

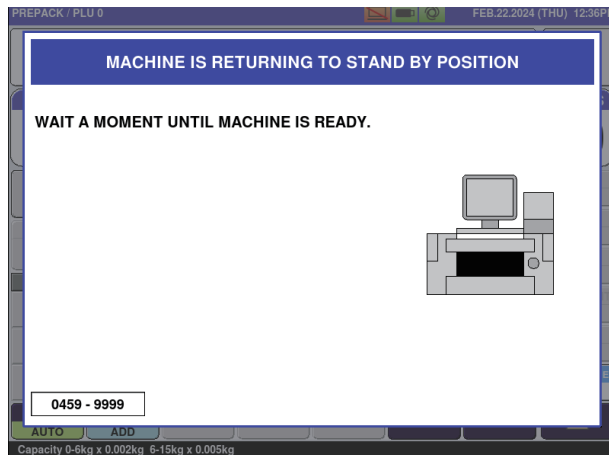

3. A screen appears that requires confirmation of the clock. Check the date and time, then touch the [ENTER] button.

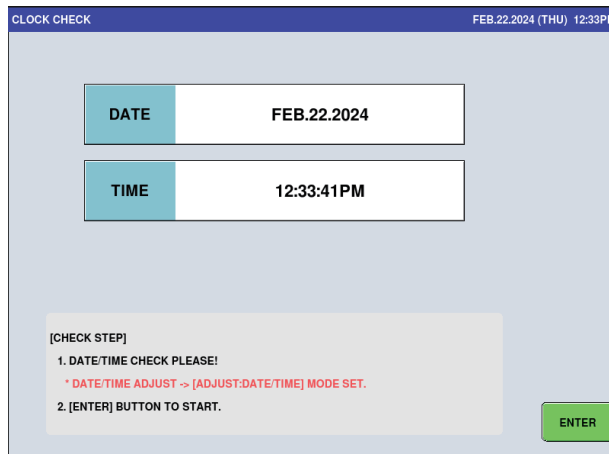

4.1.2 How to Use Preset Keys

The following preset keys are available after connecting to WM-NANO.

TRAY No. / WRAP ADJUST / CLEANING / HEATER ADJUST / WRAP STATUS / WRAP MODE / VOLUME / FILM REMOVE / FILM FEED / RETURN /

- TRAY No.

Enter a tray number and touch the [TRAY No.] preset key.

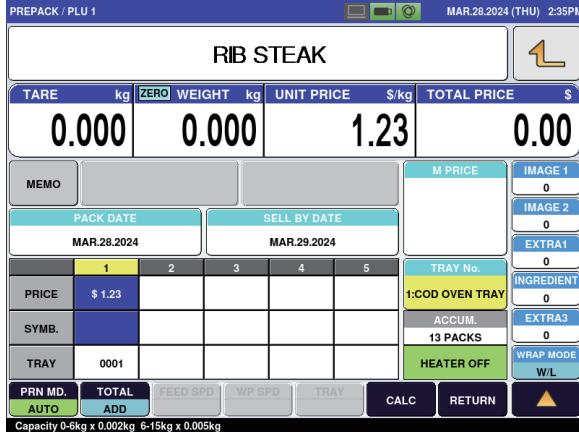

A screen for the specified tray appears.

If no tray number is entered, the tray list screen appears.

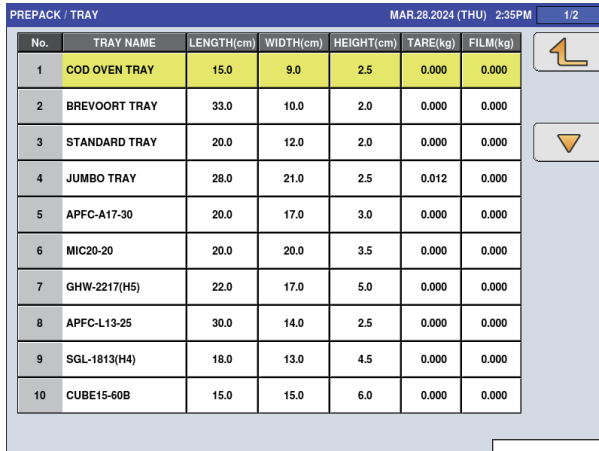

● CLEANING

Touching the [CLEANING] preset key moves up the lift and the left and right squeezing plates move toward the end for better cleaning.

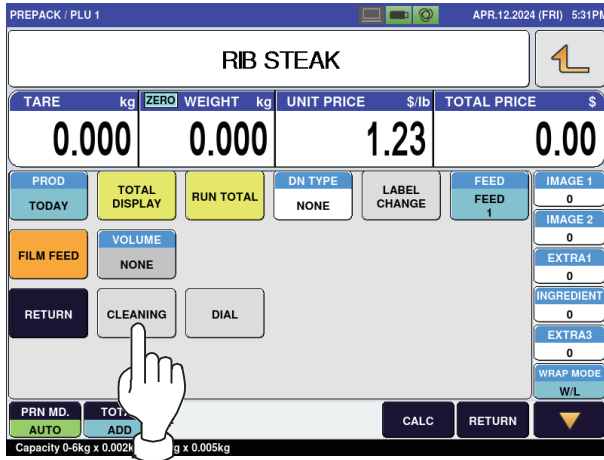

When you are ready for cleaning, touch the [START] button.

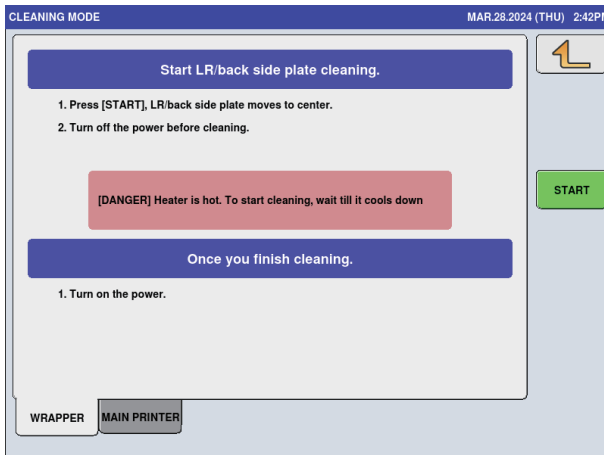

● DIAL

Touch the [DIAL] preset key.

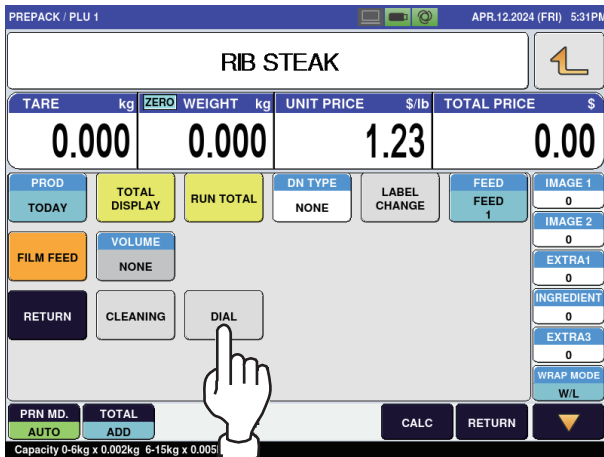

The [HEATER ADJUST] screen appears.

To change the setting, enter a value and touch the [SET] button.

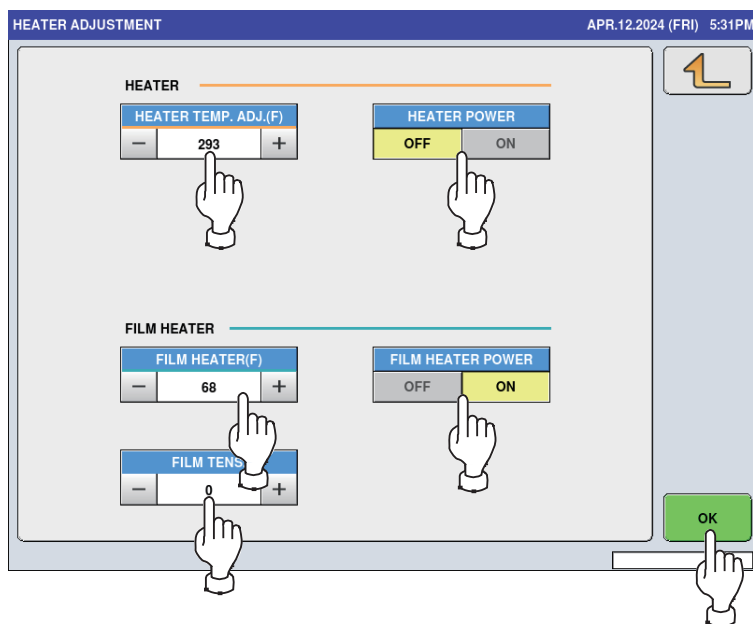

SEAL HEATER	TEMPERATURE(°C): Configures the film sealing heater temperature. (Value range: 80 to 170°C) POWER: Switches on/off the film sealing heater power.
FAN HEATER	TEMPERATURE(°C): Configures the fan heater temperature. (Value range: 0 to 40°C) POWER: Switches on/off the fan heater power.
FILM TENSION	Adjusts the film tension. Enter a relative value. (Value range: -4 to +4)

● WRAP STATUS

Touching the [WRAP STATUS] key displays the status of the wrapper.

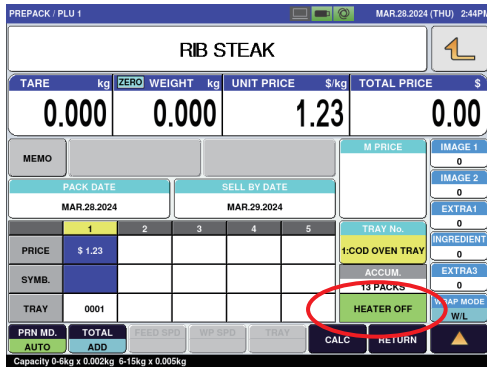

SEAL HEATER IS POWER OFF.	The film sealing heater is off.
EMRG. BTN IS PUSHED.	The emergency stop button pressed.
SEAL HEATER IS POWER ON(***)	The film sealing heater is on. (Blue: Low, Green: Normal (setup value +/- 10°C), Red:High)

● WRAP MODE

Touching the [WRAP MODE] preset key allows you to switch between wrapping modes of the product master.

You can select from [WRAP+PRINT]/[WRAP]/[PRINT] for [WRAP MODE].

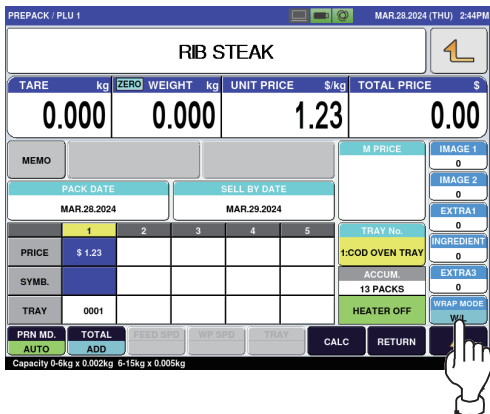

● VOLUME

Touching the [VOLUME] preset key allows you to switch between volumes the product master. You can select from FLAT/LOW/MIDDLE/HIGH for [VOLUME].

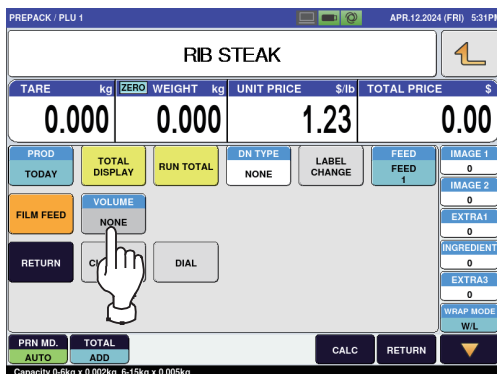

● REMOVE FILM

Touching the [REMOVE FILM] preset key allows you to cut the film and remove it from the wrapper.



● FILM FEED

Touching the [FILM FEED] preset key feeds the film.



● RETURN

Touching the [RETURN] preset key performs return process of the drive units.



4.2 PROGRAM Mode

4.2.1 WRAP Tab Added to PLU

The WRAP tab has been added to PLU. In this screen, you can add [WRAP MODE], [TRAY No], and [VOLUME] to the product master..

1. Touch [PLU] in the PROGRAM mode screen.

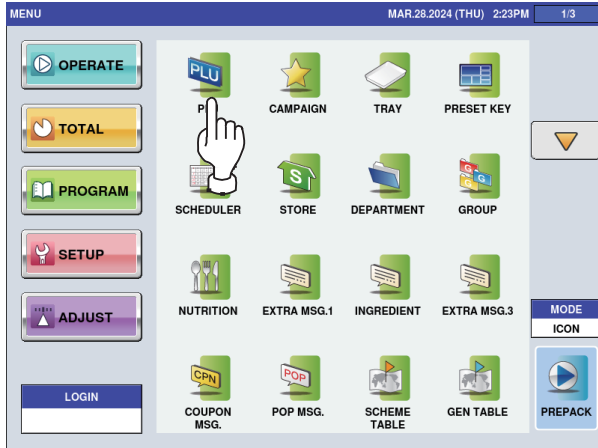

2. The [PLU] screen appears. Select designated PLU and touch [DETAIL].



3. The [PLU / DETAIL (SALE1)] screen appears.

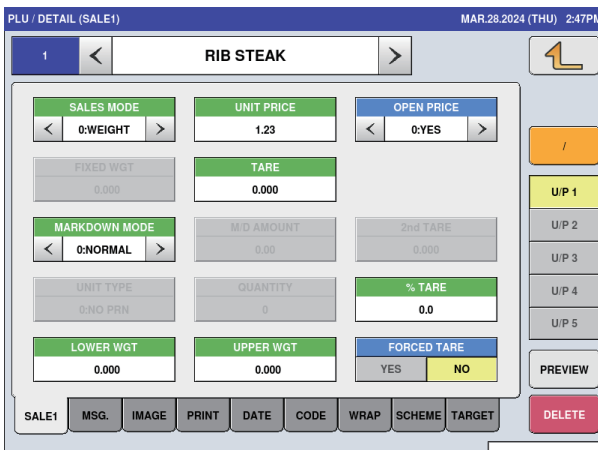

4. Touch the [WRAP] tab.
Configure [WRAP MODE], [TRAY No], and [VOLUME].

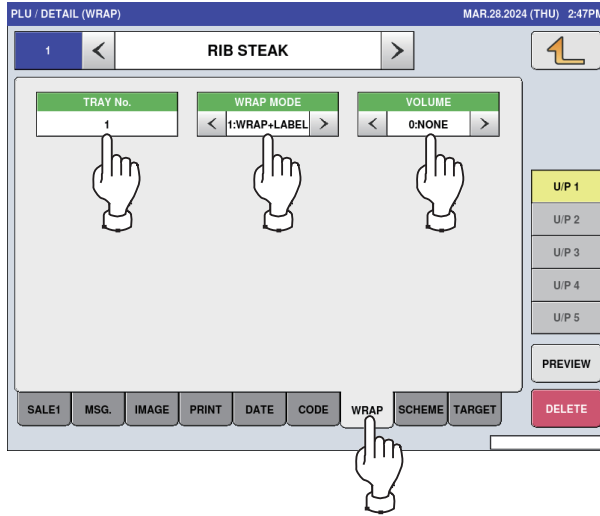

WRAP MODE	Select from [1:WR+PR(initial value)]/[2:PRINT]/[3:WRAP].
TRAY No.	Specify a value in a range from 0 to 9999. The initial value is 0.
VOLUME	Select from [0:NON (initial value)]/[1:LOW]/[2:MIDDLE]/[3:HIGH].

If no number is entered before touching the [TRAY No.] button, the tray list screen appears.

No.	TRAY NAME	LENGTH(cm)	WIDTH(cm)	HEIGHT(cm)	TARE(kg)	FILM(kg)
1	COD OVEN TRAY	15.0	9.0	2.5	0.000	0.000
2	BREVOORT TRAY	33.0	10.0	2.0	0.000	0.000
3	STANDARD TRAY	20.0	12.0	2.0	0.000	0.000
4	JUMBO TRAY	28.0	21.0	2.5	0.012	0.000
5	APFC-A17-30	20.0	17.0	3.0	0.000	0.000
6	MIC20-20	20.0	20.0	3.5	0.000	0.000
7	GHW-2217(H5)	22.0	17.0	5.0	0.000	0.000
8	APFC-L13-25	30.0	14.0	2.5	0.000	0.000
9	SGL-1813(H4)	18.0	13.0	4.5	0.000	0.000
10	CUBE15-60B	15.0	15.0	6.0	0.000	0.000

4.2.2 Preset Keys Added

Shown below are added preset keys:

TRAY No. / WRAP ADJUST / CLEANING / HEATER ADJUST / WRAP STATUS /
WRAP MODE /VOLUME / FILM REMOVE / FILM FEED / RETURN

For details of the added [preset keys, see] of the normal mode.

1. Touch [PRESET KEY] in the PROGRAM mode screen.
If [PRESET KEY] is not displayed, touch ▼ or ▲ button until it appears.

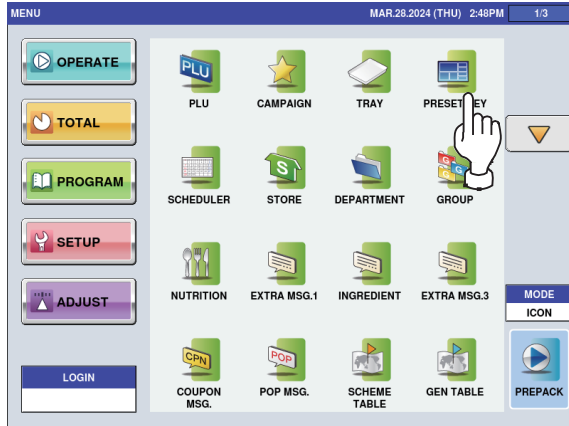

2. The [PRESET KEY] screen appears.
Select designated area and touch [DETAIL].

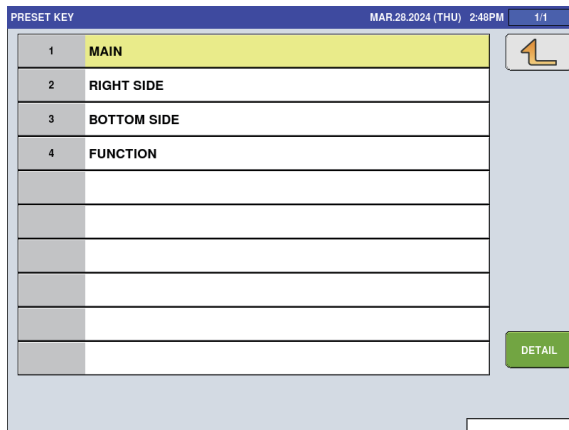

3. The [PRESET KEY (PANEL)] screen appears.
Enter a tray number and touch a key to which you want to assign the tray.

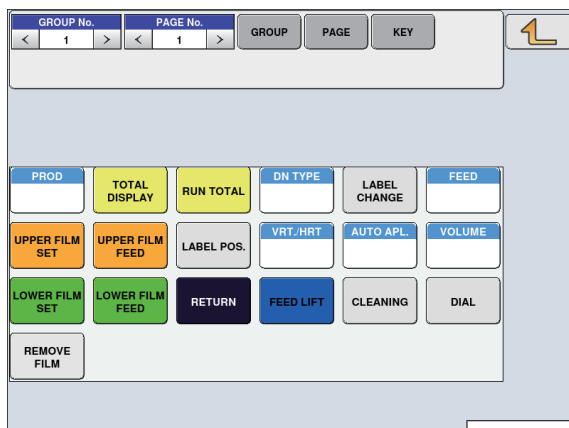

- The [FUNCTION] screen appears. The added preset keys are listed. You can select a preset key to assign.

FUNCTION		DEC.17.2023 (SUN) 10:33PM	1/7
0	NONE	11	COUPON
1	PLU	14	% TARE
2	TARE	15	RUN TOTAL
3	FIX PRICE	16	EXTRA1
4	MULTIPLY	17	INGREDIENT
5	SPECIAL	18	EXTRA3
6	-\$	19	FIX PR +WEIGHT
7	-%	20	SPECIAL(U/P)
9	POP	22	FORMAT 1
10	VOID	23	IMAGE 1

4.2.3 TRAY Added to Menu

- Touch [TRAY] in the PROGRAM mode screen. If [TRAY] is not displayed, touch ▼ or ▲ button until it appears.

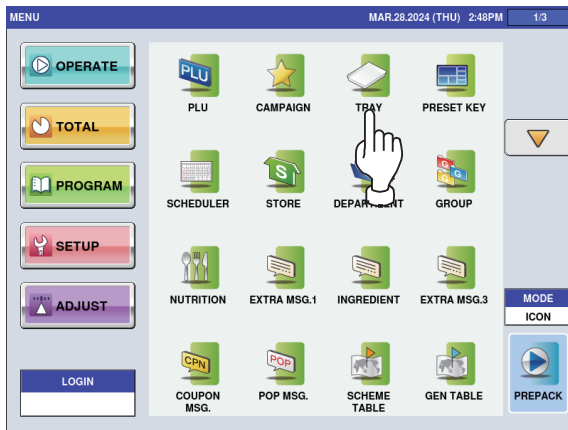

- A list of registered trays appears in the [TRAY] screen. Change: Select a tray and touch the [DETAIL] button. New registration: Touch a blank field.

TRAY							MAR.28.2024 (THU) 2:48PM	1/2
No.	TRAY NAME	LENGTH(cm)	WIDTH(cm)	HEIGHT(cm)	TARE(kg)	FILM(kg)		
1	COD OVEN TRAY	15.0	9.0	2.5	0.000	0.000		
2	BREVOORT TRA	33.0	10.0	2.0	0.000	0.000		
3	STANDARD TRA	20.0	12.0	2.0	0.000	0.000		
4	JUMBO TRAY	28.0	21.0	2.5	0.012	0.000		
5	APFC-A17-30	20.0	17.0	3.0	0.000	0.000		
6	MIC20-20	20.0	20.0	3.5	0.000	0.000		
7	GHW-2217(H5)	22.0	17.0	5.0	0.000	0.000		
8	APFC-L13-25	30.0	14.0	2.5	0.000	0.000		
9	SGL-1813(H4)	18.0	13.0	4.5	0.000	0.000		
10	CUBE15-60B	15.0	15.0	6.0	0.000	0.000		

DETAIL	Displays the selected tray.
DELETE	Resets the selected tray information to the default.

- The [TRAY(BASIC)] screen appears. You can register basic tray information.

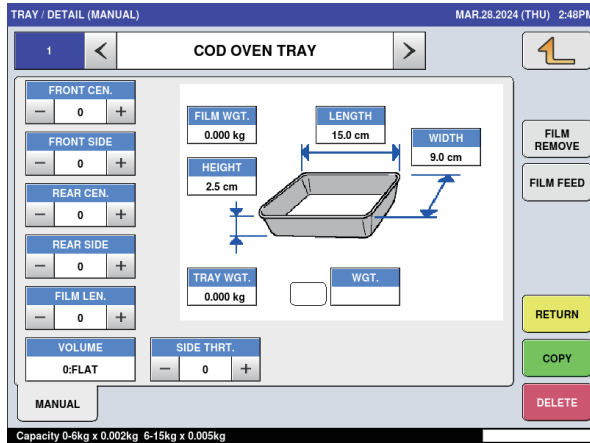

VOLUME	Indicates the height of the tray content. You cannot specify a value here.
LENGTH	Configures the tray width.
HEIGHT	Configures the tray height.
WIDTH	Configures the tray depth.
TRAY WGT	Configures the tray weight.
FILM WGT	Configures the film weight.
WEIGHT	Displays the weight of the weighing target.
EDIT	Displays the tray name edit screen.
COPY	Copies the tray information acquired by entering the tray number to the current tray.
RETURN	Returns the mechanism to the initial positions.
DELETE	Deletes the tray being selected.
FRONT CEN. / FRONT SIDE	Adjusts the film tension with the front clamp. The larger the clamping time (larger + value), the larger the film tension becomes. The smaller (larger - value), the smaller the tension becomes.
REAR CEN. REAR SIDE.	Adjusts the film tension with the back clamp. The larger the clamping time (larger + value), the larger the film tension becomes. The smaller (larger - value), the smaller the tension becomes.

CAUTION The [TRAY(ADJUST2)] screen is provided specifically for the manufacturer. Incorrect setting may cause damage of the product or commodities. Do not change the setting unless you are qualified to do so. To display the [TRAY(ADJUST2)] screen, the password is required.

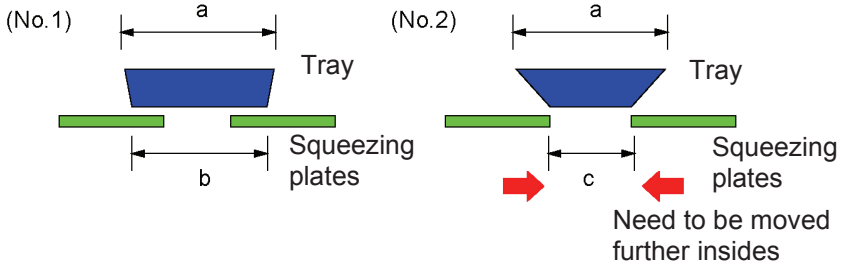
SIDE THRT	<p>Adjusts the movement (squeezing amount) of the left and right squeezing plates.</p> <p><> buttons: Squeeze outside, >< buttons: Squeeze inside</p> <p>For tray registration, enter the upper-end dimensions (wider/narrower side) "a" of the tray as shown in the figure below. The left and right squeezing plates operate based on the dimensions.</p> <p>If the bottom size of the tray is like the example (No.2), you must squeeze more than for the size "b". Otherwise the film may not be sufficiently attached to the bottom. In such a case, use SIDE THRT.</p> 
-----------	---

- The default wrapping conditions are calculated based on the tray width, depth, and height.
- Specify a relative value from the default for each item. Specifying a +5 value for an item configures the operation as +5 timing or amount to its default value.
- Common items are linked between [TRAY(BASIC)], [TRAY(ADJUST1)], and [TRAY(ADJUST2)] screens.
(A change of a value in one screen is reflected to the other screens)
- You can enter a value in a range from -99 to +99. Even if you enter a value over the limit for the item, the operation shall be done with the limit value.
- Limit values differ for the items. They differ for tray sizes and film widths as well.

4.3 SETUP Mode

4.3.1 Switching to Service Mode

To display all menu items of the SETUP mode, switch to the Service Mode.

1. In the SETUP mode screen, enter "495344" and touch the [PLU] key.

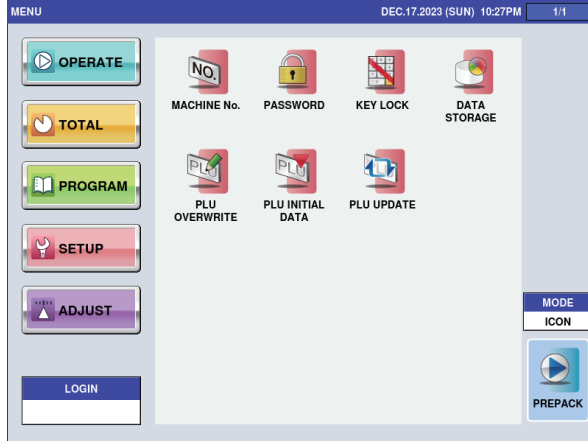

The hidden menu appears.

4.3.2 FUNCTION KEY Items Added to KEY LOCK

The following items are added to the [FUNCTION KEY] tab of [KEY LOCK].

WARP MODE / TRAY / TRAYNo. / TRAYNAME / WRAP ADJUST / HEATER ADJUST / VOLUME / CLEANIG

1. Touch [KEY LOCK] in the SETUP mode screen.
If [KEY LOCK] is not displayed, touch ▼ or ▲ button until it appears.

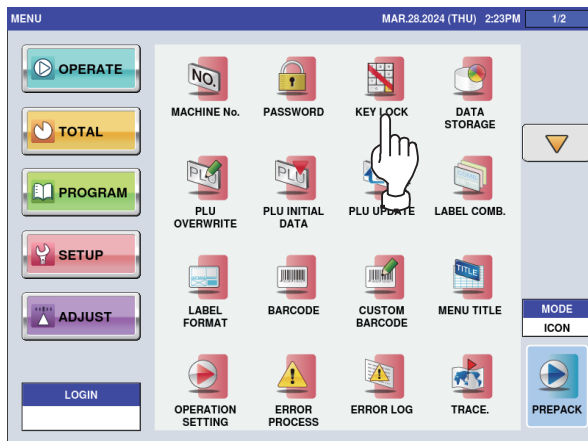

- The [KEY LOCK (DISPLAY KEY)] screen appears. Touch the [KEY LOCK(FUNCTION KEY)] tab. (The items in the red frames shown below have been added).

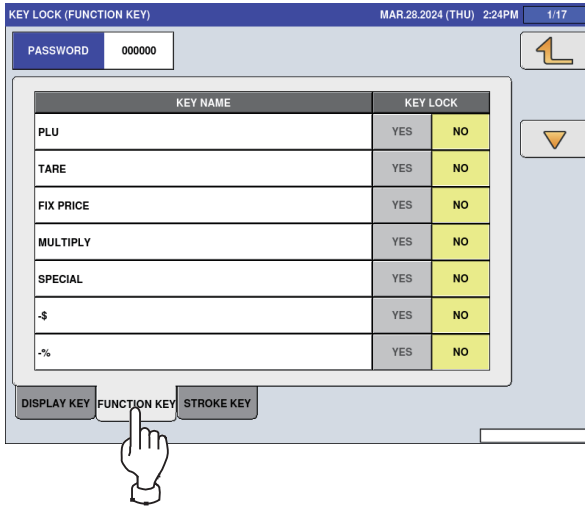

Touch ▼ or ▲ button to display an item you want.

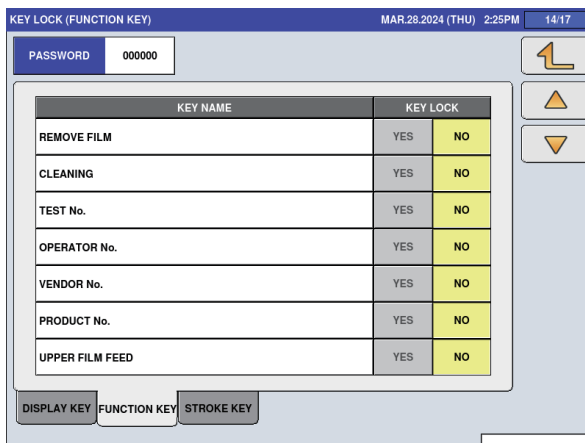
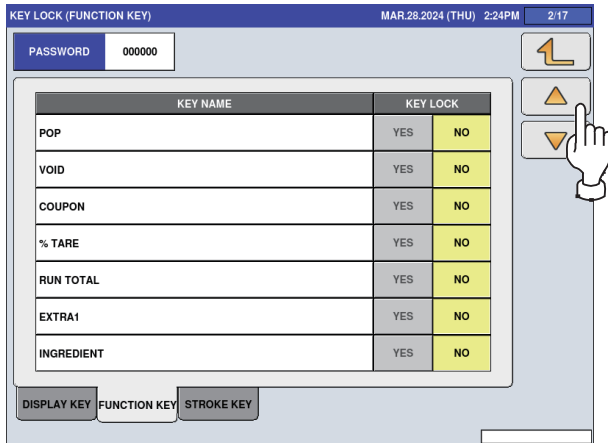

- To change the KEY LOCK, touch [YES] or [NO] in the item.

4.3.3 Items Added to PLU OVERWRITE

Items of TRAY No / WRAP MODE / VOLUME have been added to [PLU OVERWRITE].

1. Touch [PLU OVERWRITE] in the SETUP mode screen.
If [PLU OVERWRITE] is not displayed, touch ▼ or ▲ button until it appears.

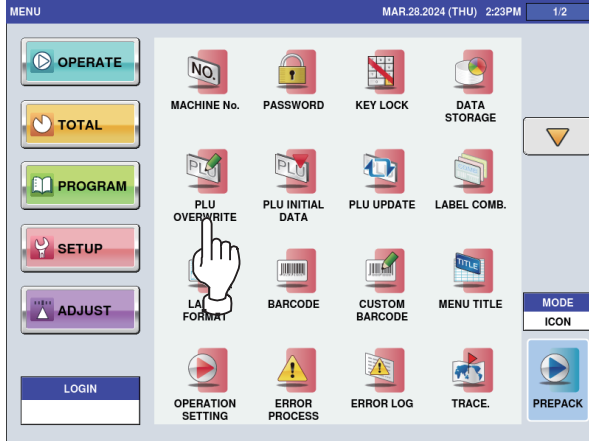

2. The [PLU OVERWRITE] screen appears.
Touch ▼ or ▲ button to display an item you want.

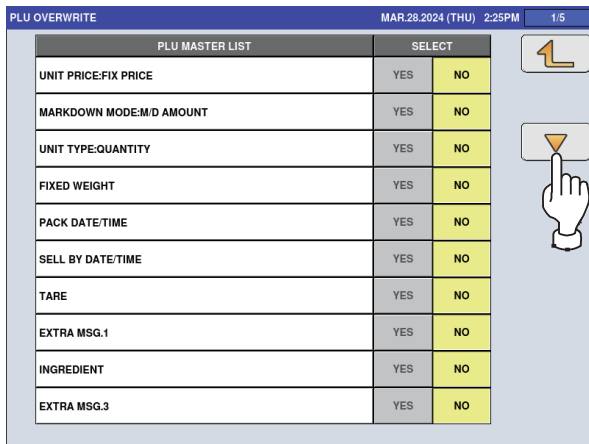

The items in the red frames shown below have been added.

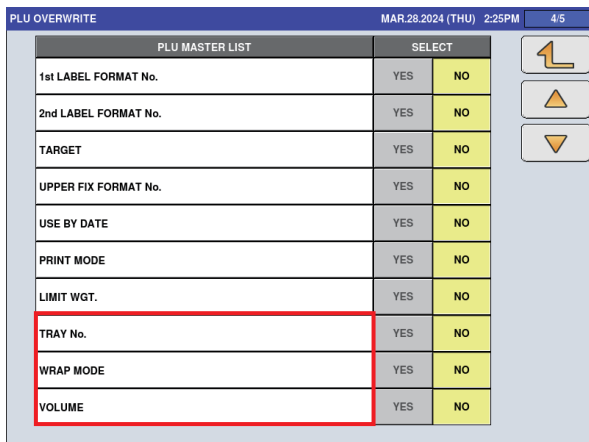

4.3.4 WRAP Tab Added to PLU INITIAL DATA

The WRAP tab (TRAY No / WRAP MODE / VOLUME) has been added to [PLU INITIAL DATA].

1. Touch [PLU INITIAL DATA] in the SETUP mode screen.
If [PLU INITIAL DATA] is not displayed, touch ▼ or ▲ button until it appears.

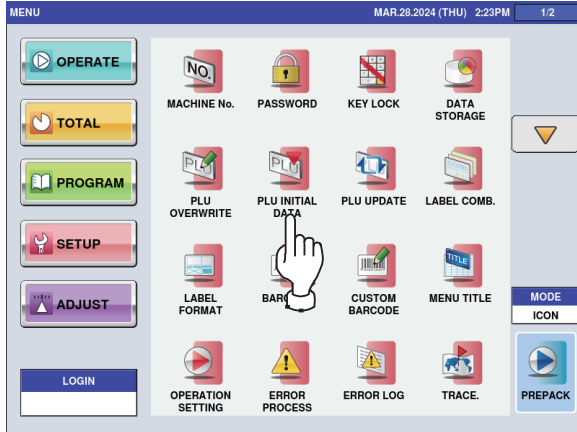

2. The [PLU INITIAL DATA] screen appears. Touch the [WRAP] tab.

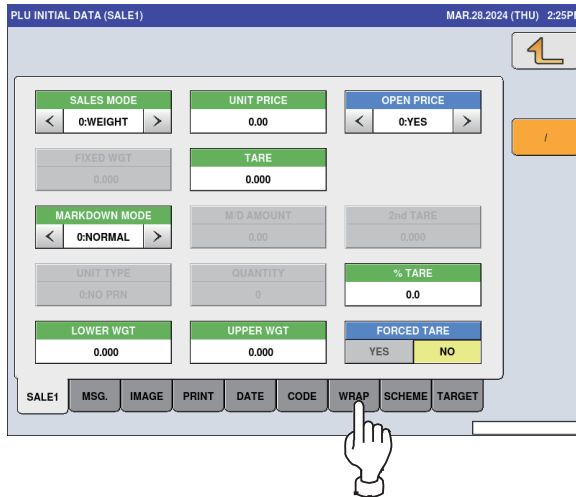

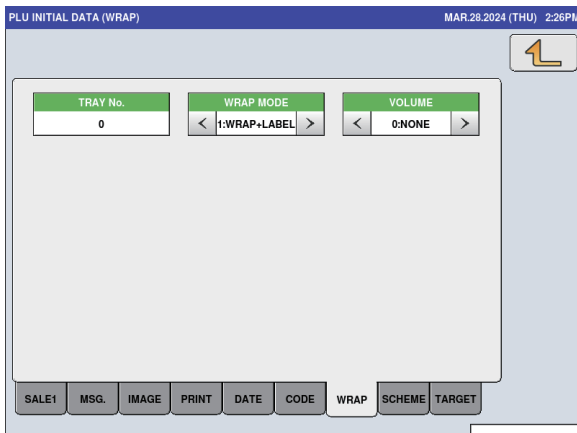

3. Configure [WRAP MODE], [TRAY No], and [VOLUME].



WRAP MODE	Select from [1:WR+PR(initial value)]/[2:PRINT]/[3:WRAP].
TRAY No.	Specify a value in a range from 0 to 9999. The initial value is 0.

If no number is entered before touching the [TRAY No.] button, the tray list screen appears. You can select a tray to configure.

TRAY							MAR.28.2024 (THU) 2:47PM		1/2
No.	TRAY NAME	LENGTH(cm)	WIDTH(cm)	HEIGHT(cm)	TARE(kg)	FILM(kg)			
1	COD OVEN TRAY	15.0	9.0	2.5	0.000	0.000	 		
2	BREVOORT TRAY	33.0	10.0	2.0	0.000	0.000			
3	STANDARD TRAY	20.0	12.0	2.0	0.000	0.000			
4	JUMBO TRAY	28.0	21.0	2.5	0.012	0.000			
5	APFC-A17-30	20.0	17.0	3.0	0.000	0.000			
6	MIC20-20	20.0	20.0	3.5	0.000	0.000			
7	GHW-2217(H5)	22.0	17.0	5.0	0.000	0.000			
8	APFC-L13-25	30.0	14.0	2.5	0.000	0.000			
9	SGL-1813(H4)	18.0	13.0	4.5	0.000	0.000			
10	CUBE15-60B	15.0	15.0	6.0	0.000	0.000			



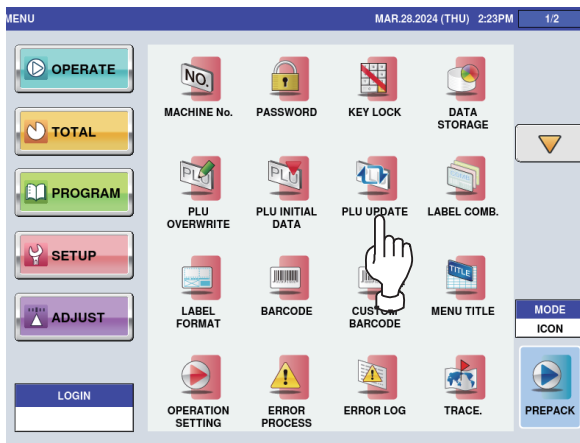

4.3.5 Items Added to PLU UPDATE

Items of TRAY No / WRAP MODE / VOLUME have been added to [PLU UPDATE].

1. Touch [PLU UPDATE] in the SETUP mode screen.
If [PLU UPDATE] is not displayed, touch ▼ or ▲ button until it appears.



2. The [PLU UPDATE] screen appears.

PLU UPDATE							MAR.28.2024 (THU) 2:26PM		1/14
CHANGE RANGE							   		
START No.	END No.								
1	99999999								
UNIT PRICE No.					CONDITION				
1	2	3	4	5	NO	YES			
No.	LIST NAME	REPLACE CONDITION	CHANGE CONTENTS						
1	ITEM CODE								
2	PACK DATE PRINT								
3	PACK TIME PRINT								
4	PACK TIME DATA								
5	SELL BY DATE PRINT								
6	SELL BY TIME PRINT								

3. Touch ▼ or ▲ button to display an item you want.
The items in the red frames shown below have been added.

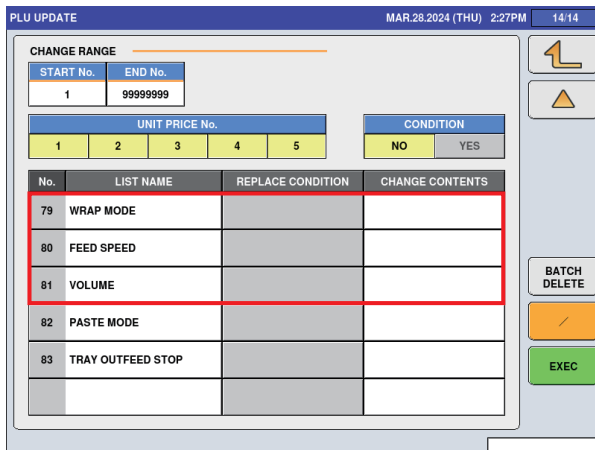
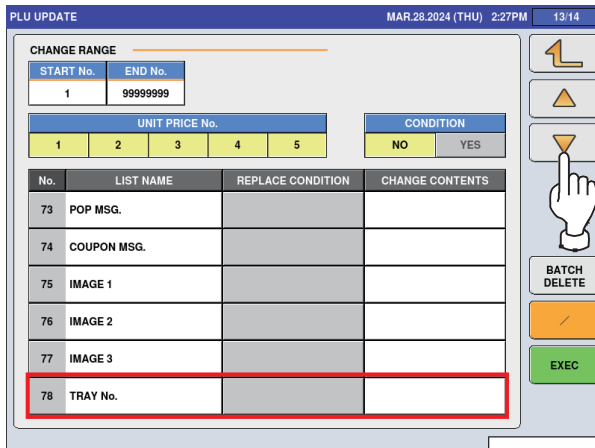

4.3.6 COUNTRY (MISC) Screen Added

The [COUNTRY(MISC) WRAP] screen has been added to COUNTRY. You can change a temperature unit and/or configure network connection with the host system.

1. Touch [COUNTRY] in the SETUP mode screen.
If [COUNTRY] is not displayed, touch ▼ or ▲ button until it appears.

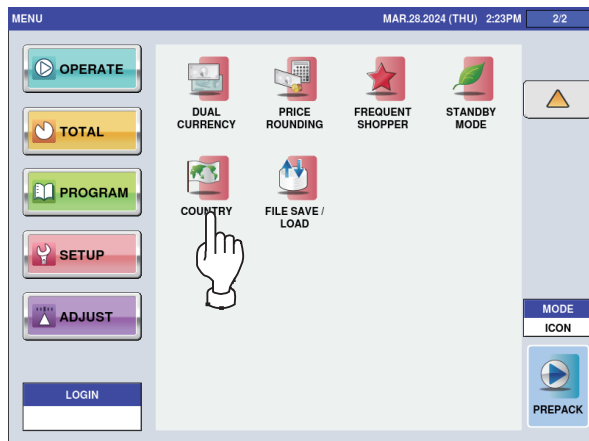

- The [COUNTRY] screen appears.
Enter 495344 and touch [DETAIL] button.

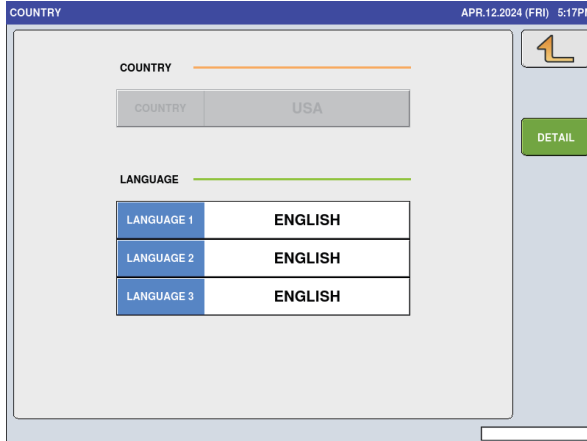

- The [COUNTRY(CURRENCY)] screen appears.
You can change a temperature unit.

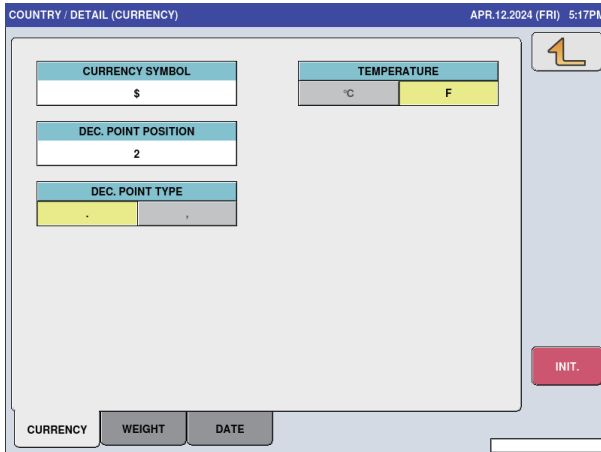

TEMPERATURE	Switches the temperature indication between °C (Celsius) and F (Fahrenheit).
-------------	--

4.3.7 Tray Master Added to FILE SAVE / LOAD

The tray master has been added to the master list of [FILE SAVE / LOAD].

1. Insert a USB memory stick to the USB connector
2. Touch [FILE SAVE / LOAD] in the SETUP mode screen.
If [FILE SAVE / LOAD] is not displayed, touch ▼ or ▲ button until it appears.

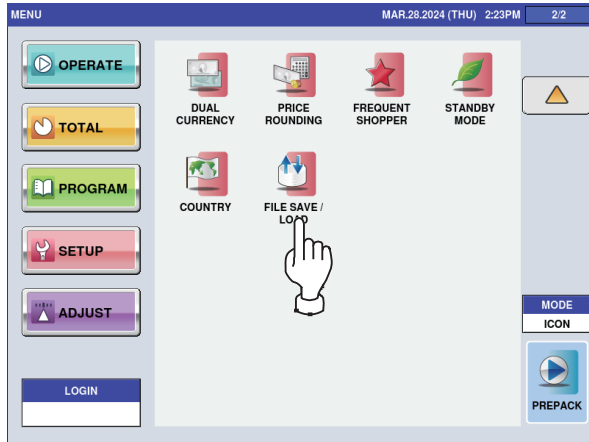

3. The [FILE SAVE / LOAD (USB > SCALE)] screen appears.
Touching the [DETAIL] button allows fine-adjustment of file input/output.

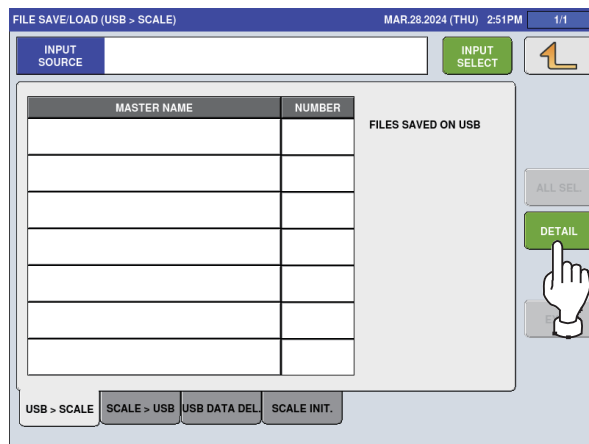

4. Select a tab to perform file input/output of a tray master.
 - To input a tray master from a USB memory stick
Select a tray master and touch [EXEC].

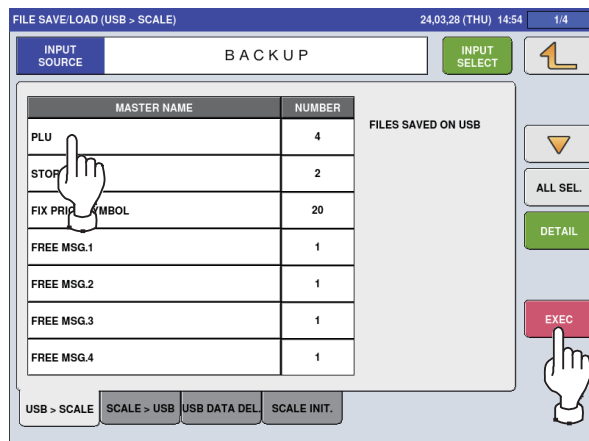

● To output to a USB memory stick

- 1) Touch the [SCALE > USB] tab.
- 2) Select a tray master and touch [EXEC].

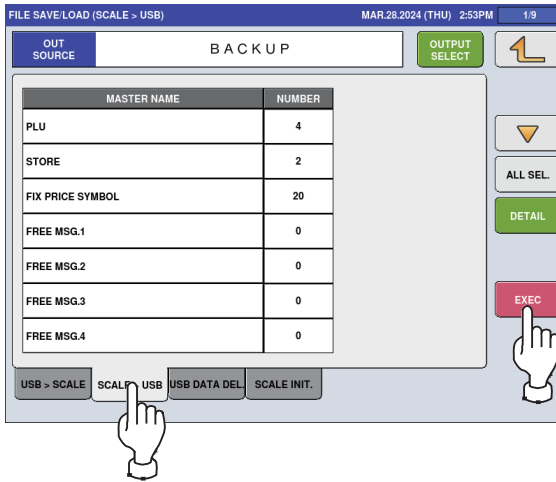

● To delete a tray master in a USB memory stick

- 1) Touch the [SCALE > USB] tab.
- 2) Select a tray master and touch [EXEC].

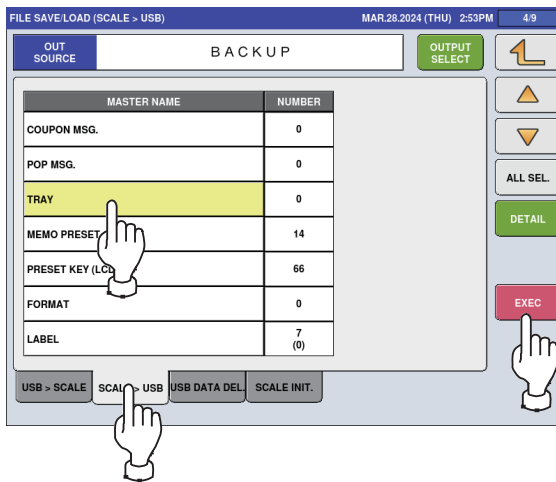

● To initialize an internal tray master

- 1) Touch the [SCALE INIT.] tab.
- 2) Select a tray master and touch [EXECUTE].

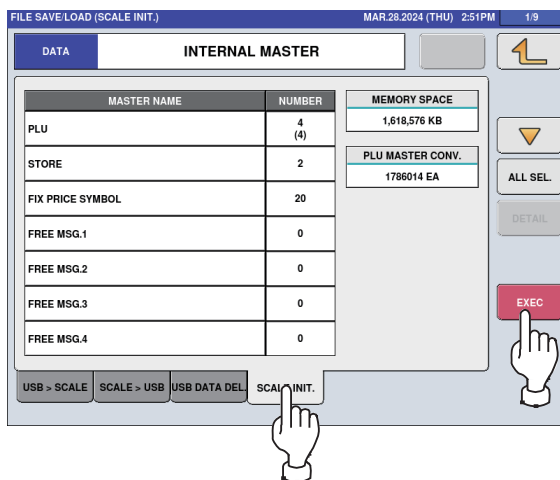

5. The confirmation screen appears. To execute, touch the [EXEC] button.

4.4 ADJUST Mode

4.4.1 Switching to Service Mode

To display all menu items of the ADJUST mode, switch to the Service Mode.

1. In the ADJUST mode screen, enter "495344" and touch the [PLU] key.

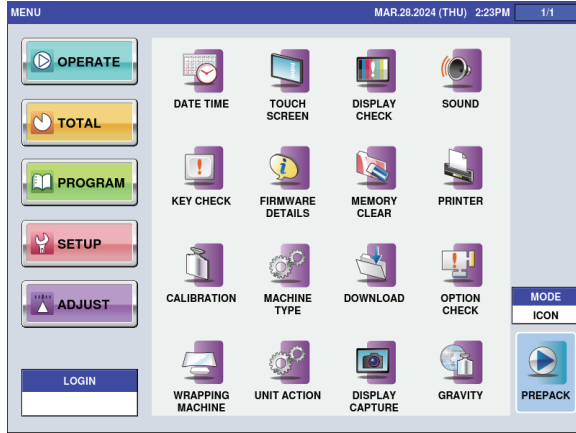

The hidden menu appears.

4.4.2 MEMORY CLEAR Items Added

The following items are added to the [FUNCTION KEY] tab of [KEY LOCK].

1. Touch [MEMORY CLEAR] in the ADJUST mode screen.
If [MEMORY CLEAR] is not displayed, touch ▼ or ▲ button until it appears.

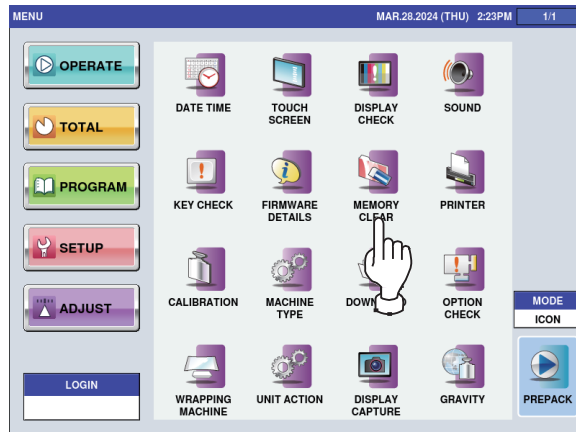

2. Touch an item you want to perform memory clear.

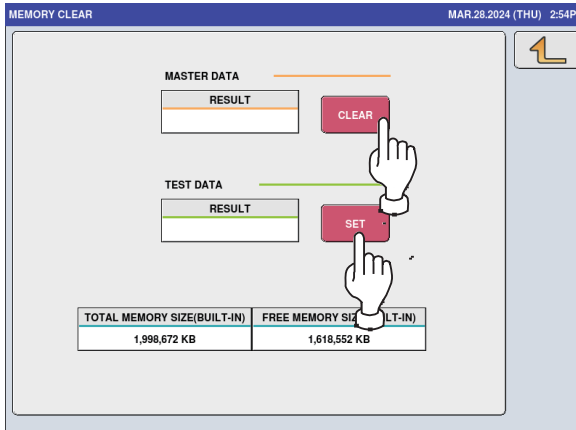

MASTER DATA CLEAR	RESULT: Displays the execution result of the master data clear. CLEAR: Clears master data other than the device-specific information and configures minimum required data for operation.
TEST DATA SET	RESULT: Displays the execution result of the test data registration. SET: Registers test data for adjustment (product master/tray master).
MEMORY SIZE	Displays SRAM, FLASH, SDRAM, and CF memory.

3. The confirmation screen appears. To execute, touch [EXEC].

4.4.3 SUB Tab Added to DOWN LOAD

The following items are added to the [FUNCTION KEY] tab of [KEY LOCK].

1. Insert a USB memory stick to the USB connector.
2. Touch [DOWN LOAD] in the ADJUST mode screen.
If [DOWN LOAD] is not displayed, touch ▼ or ▲ button until it appears.

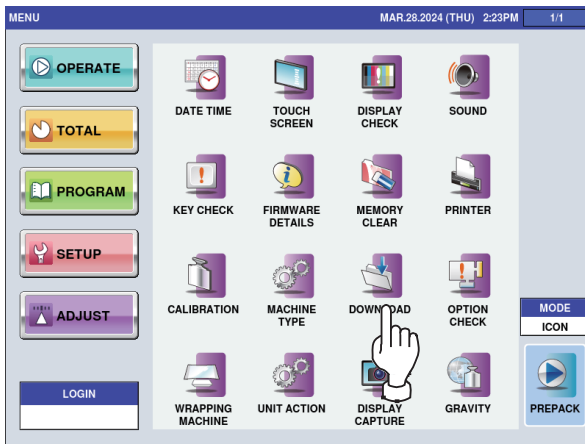

3. The [DOWNLOAD (MAIN)] screen appears.

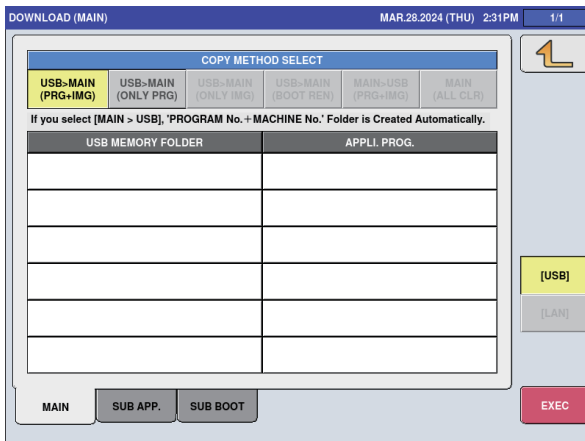

4. Touch the [SUB APP.] tab.
Select a program, destination peripheral device, and copy source, and touch the [EXEC] button.

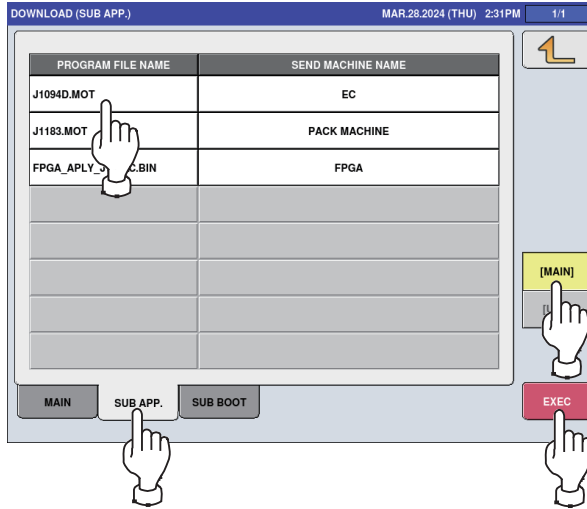

PROGRAM FILE NAME	Specifies a program.
SEND MACHINE NAME	Specifies a destination peripheral device for downloading.
MAIN	Specifies a program in the main unit's flash ROM as the source.
SUB	Specifies a program in the USB memory as the source.
EXEC	Executes download.

5. The confirmation screen appears. To execute, touch [EXEC].

4.4.4 WRAPPING MACHIN Added to Menu

The [WRAPPING MACHINE] has been added to the ADJUST mode menu. You can configure the wrapper setting through this function.

1. Touch [MEMORY CLEAR] in the ADJUST mode screen.
If [MEMORY CLEAR] is not displayed, touch ▼ or ▲ button until it appears.

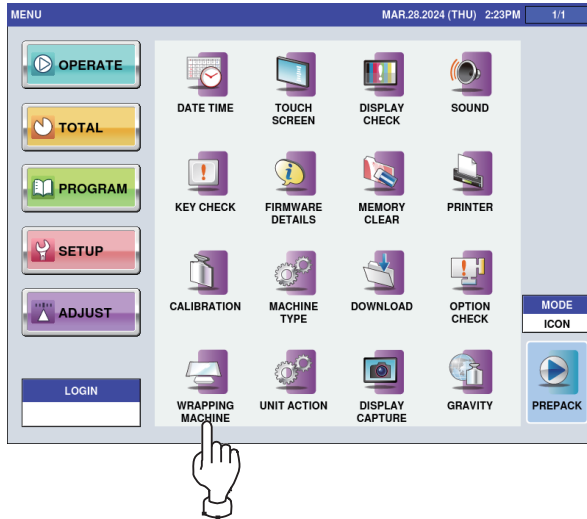

2. The [WRAPPER (INITIAL)] screen appears.
You can configure the wrapper setting in each tab.
 - To initialize wrapper setting or wrapping count
 - 1) Touch the [INITIAL] tab.
 - 2) To initialize the wrapper setting, touch the [INIT.] button. To clear the wrapping count, touch the [CLEAR] button.

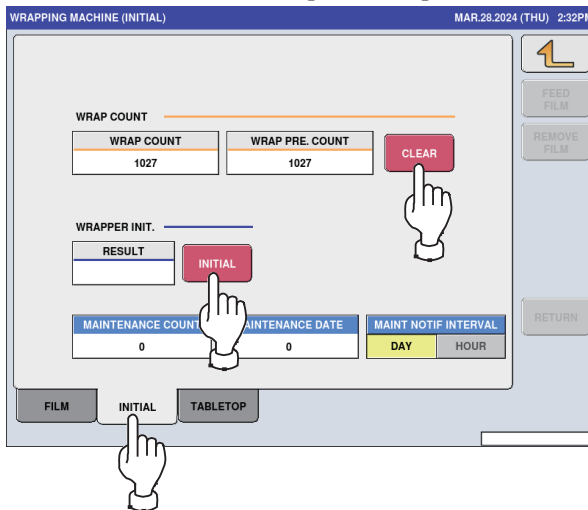

INITIAL WRAPPER	RESULT: Displays the execution result of the initialization. INIT. button: Initializes the wrapper setting data.
WRAP COUNT	TOTAL COUNT: Displays the accumulated wrapping count. PER. COUNT: Displays the wrapping count. CLEAR button: Clears the PER. COUNT wrapping count. * To clear the TOTAL COUNT wrapping count, enter "495344" and touch the [CLEAR] button.

- To configure film
 - 1) Touch the [FILM] tab.
 - 2) Specify setup value(s).

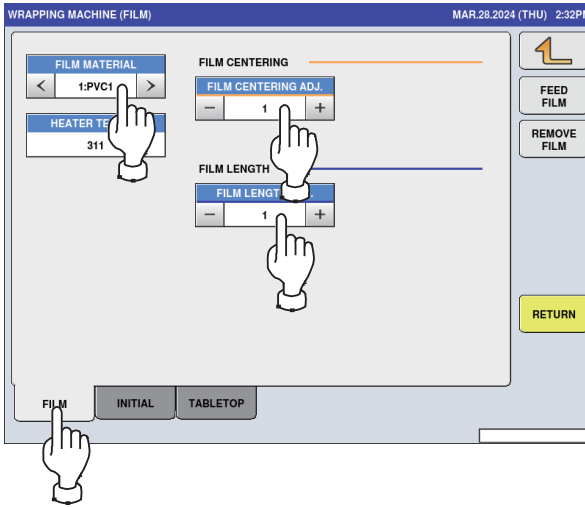

<p>FILM MATERIAL</p>	<p>Touch < or > key to select a film material from: 1:PVC1 2:POLY1 * [1:PVC1] and [2:POLY1] have different setup temperatures of the sealing heater, while they are the same in the wrapping operation. * [3:PVC FILM2] has a different film conveying operation. Use this setting if the film is hard to peel off from the roll.</p>
<p>FILM CENTERING ADJ.</p>	<p>Adjusts the stop position of the film for feeding. Forward: Moving to the right (film conveying direction) Backward: Moving to the left The input range is from -99 to 99. The initial value is 0.</p>
<p>FILM LENGTH ADJ.</p>	<p>Adjusts the length of the film for feeding. Forward: Longer Backward: Shorter The input range is from -99 to 99. The initial value is 0.</p>

- To configure temperature check or film detection
 - 1) Touch the [TABLETOP] tab.
 - 2) Configure temperature check or film detection.

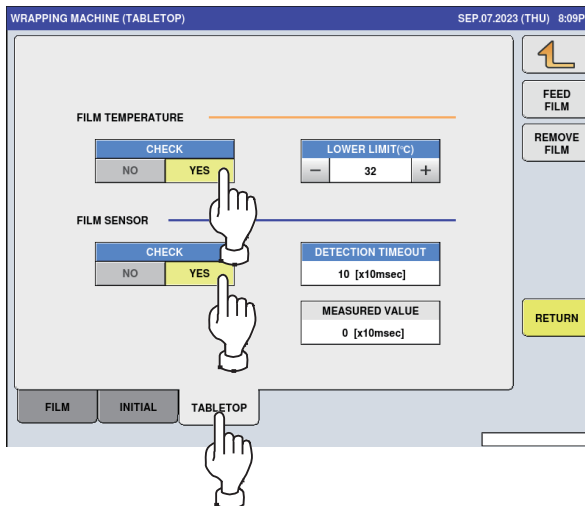

FILM TEMPERATURE	CHECK: Configures if the temperature in the wrapper should be checked before wrapping.
FILM SENSOR	CHECK: Specifies if the film existence should be detected for film feeding. DETECTION TIMEOUT: Specifies a time to determine that there is no film detected. MEASURED VALUE: Displays the actual time of film detection.

4.4.5 UNIT ACTION Added to Menu

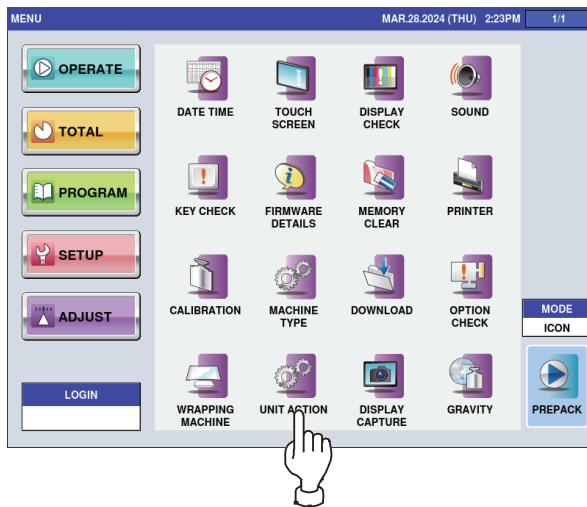

The [UNIT ACTION] has been added to the ADJUST mode menu. You can use this function to operate the units for test.

1. Touch [UNIT ACTION] in the ADJUST mode screen.
If [UNIT ACTION] is not displayed, touch ▼ or ▲ button until it appears.

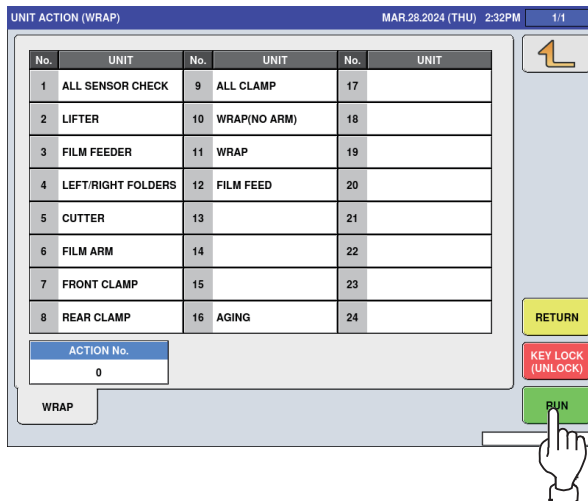

2. Select a unit you want to operate and touch [RUN].
If the unit is not displayed, touch ▼ or ▲ button until it appears.



RETURN	Returns the mechanism to the initial positions.
TEST No.	Specifies a unit to operate. Enter a value to specify. (0 means operation stop)
EXECUTE	Operates the unit of the specified number.
KEY(UNLOCK)	 Releases the key lock.
KEY(ONLY STOP)	 Locks the key.

4.4.6 MACHINE TYPE Added to Menu

The [MACHINE TYPE] has been added to the ADJUST mode menu. You can use this function to set the machine type.

1. Touch [UNIT ACTION] in the ADJUST mode screen.
If [UNIT ACTION] is not displayed, touch ▼ or ▲ button until it appears.

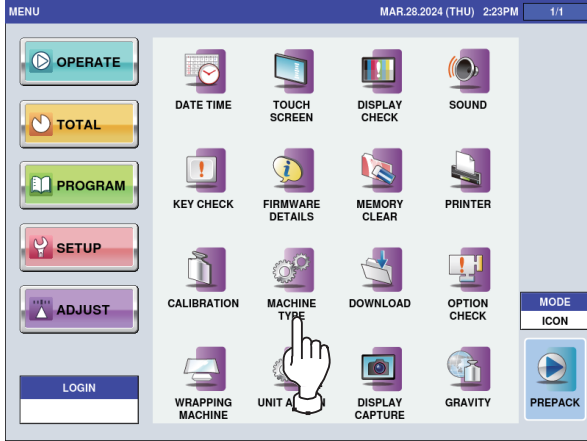

2. Select the machine type.

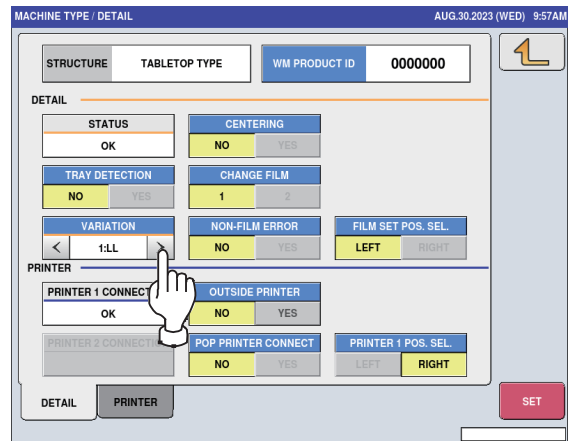
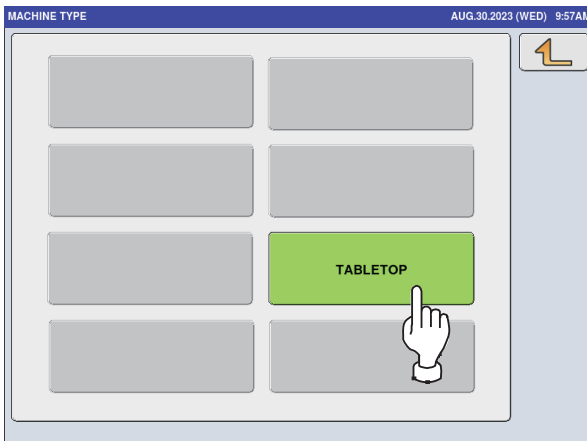

<p>VARIATION</p>	<p>Select the machine variation. L: EU specifications LL: US specifications</p>
------------------	---

4.4.7 Main board replacement

■ Downloading Software

CAUTION

Be sure to download the latest software.

Do not download the software for P-1180B only, to P-1180C. If the software is wrong, the wrong FG / FPGA software is displayed and download will not be executed.

P-1180, the main board for WM-MICRO, has applications inside the flash ROM. At shipment, basic software, called boot-software, is installed on the main board for maintenance. Since no application to run exists on the board, it is not operational but only a logo of Ishida appears on the screen after power is turned on. Without application, however, the machine can be activated using the application from the USB flash memory, and then software is automatically downloaded from the “Soft” folder in the USB flash memory to the main board.

When using the USB flash memory for startup, after application has been downloaded to the main board, remove the USB flash memory and restart the machine before you start the work. If directly started from the USB flash memory, the setting may not be properly reflected to the memory of the main body.

Basically, the copy function of “USB > MAIN” only overwrites a file to the flash ROM and does not delete unnecessary files. If an unnecessary file is accidentally copied, the flash ROM capacity will be consumed, which may cause a copy error of the program file due to capacity shortage. In this case, delete all and copy it again.

If a program of another model is accidentally copied, the machine may not be operational. In this case, restart the machine from the USB flash memory, delete all, and copy the correct program file again.

* To copy the backed up software to the main board, make settings again on the [DOWNLOAD] screen of ADJUST mode after the downloading is automatically completed.

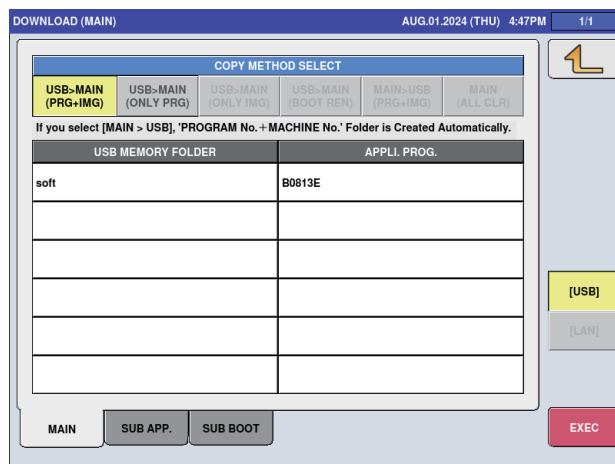

DOWNLOAD (MAIN) screen

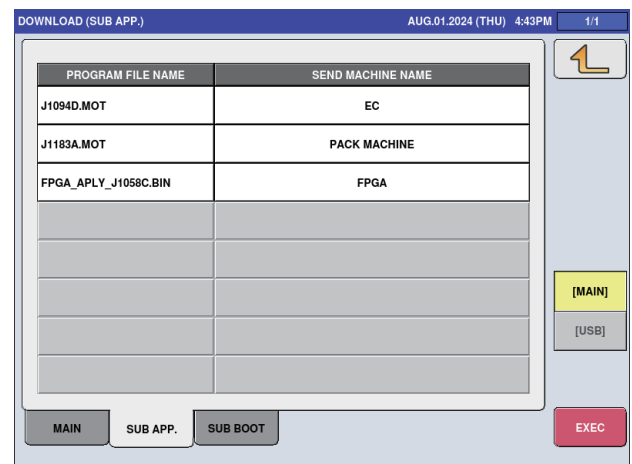

DOWNLOAD (SUB APP.) screen

Printer adjustment

After the replacement of the main board and downloading the main software, download the EC / FPGA software on the DOWNLOAD (SUB APP.) screen.

When download is completed, “Reboot Check” confirmation screen will be displayed so manually reboot the machine.

Then, initialize the printer on the PRINTER screen, and adjust the label sensor.

For the detail of printer adjustment, please refer to “3.9 Printer” or “3.10 Printer (Linerless)”.

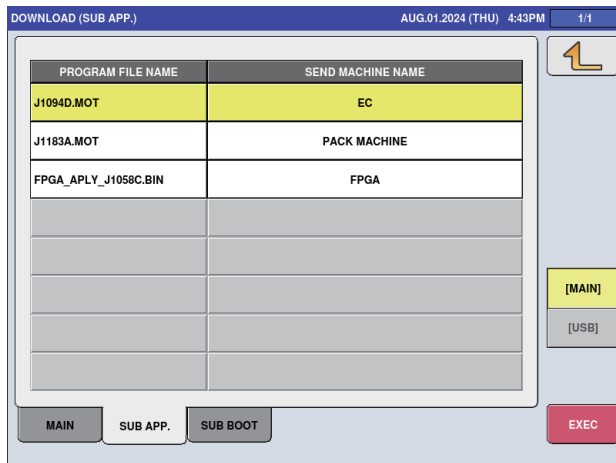

DOWNLOAD (SUB APP.) screen

Download and install EC / FPGA software.

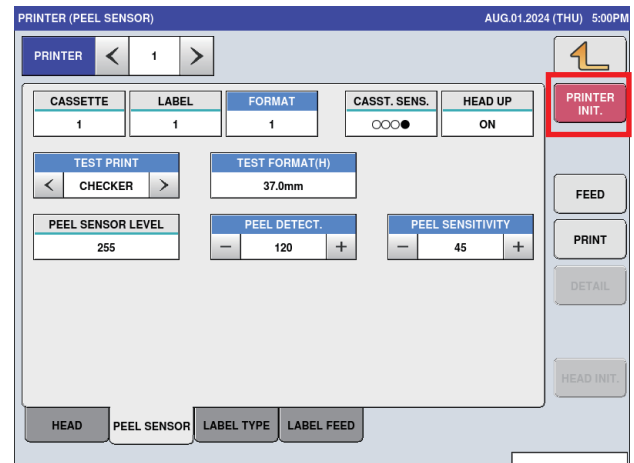

PRINTER (HEAD) screen

Initialize the printer.

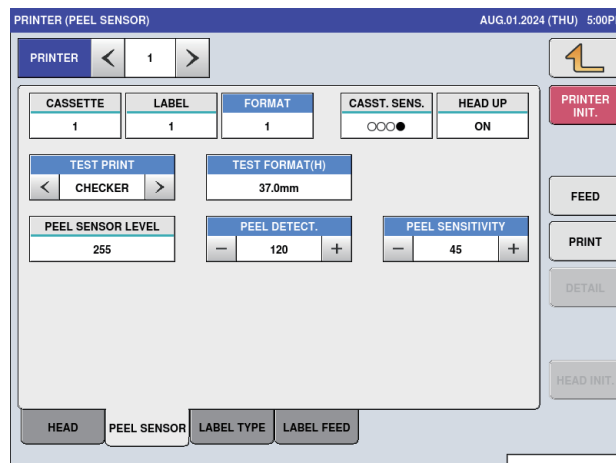

PRINTER (PEEL SENSOR) screen

Adjust the label sensor.

Chapter 5 Hardware (Mechanical)

5.1 Removing Units

5.1.1 Removing the Infeed Unit



1. Remove the weighing table.

2. Remove the garbage tray.



3. Remove 4 screws on both sides to remove the front cover.



4. Remove 6 screws that fix the right cover of the machine.



5. Remove the right cover



6. Remove 6 screws that fix the left cover of the machine.



7. Remove the left cover.

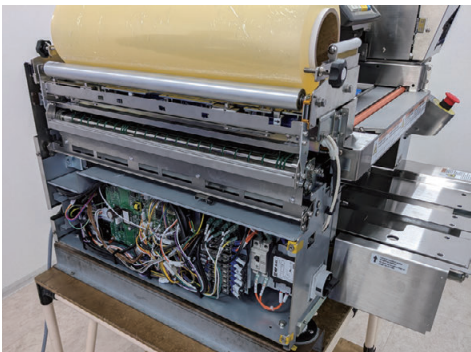

8. Release the coupling between the infeed arm and the infeed bar.

8-1. Loosen 1 screw of the infeed arm.

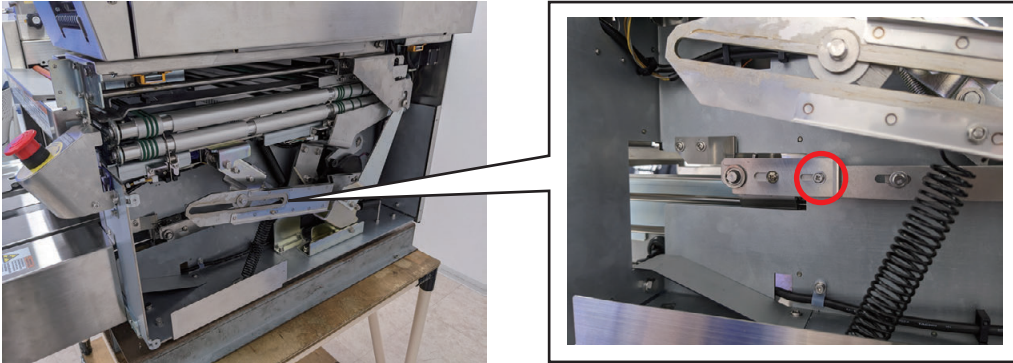

8-2. Slide the tab and decouple the infeed arm.

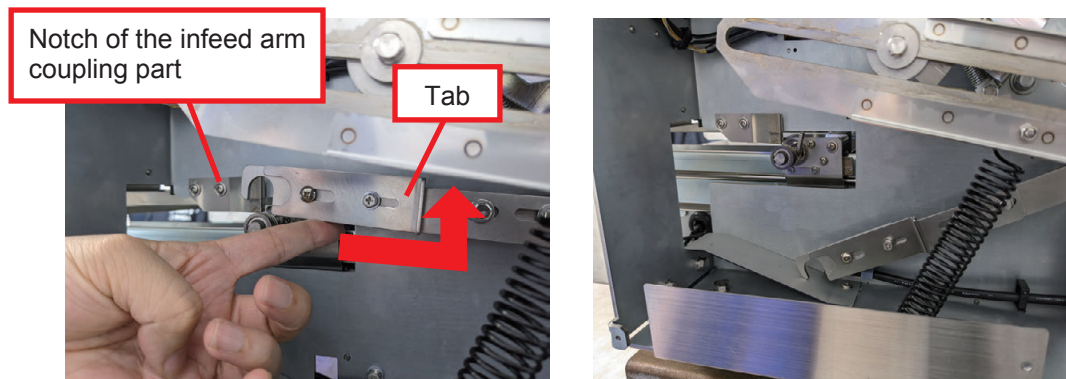

9. Remove 3 screws to remove the cover.



10. Open the cable holder and unplug the connector.



11. Remove 2 screws to remove the cover.

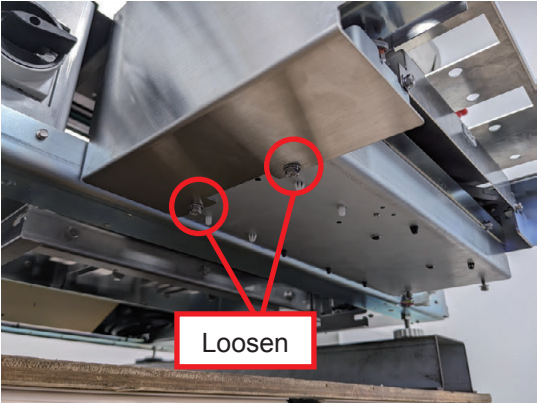

12. Remove left and right side 2 screws that fix the infeed unit to the machine body.



13. Remove the infeed unit from the left and right side notches in the back. Then pull out the infeed unit from the machine body.

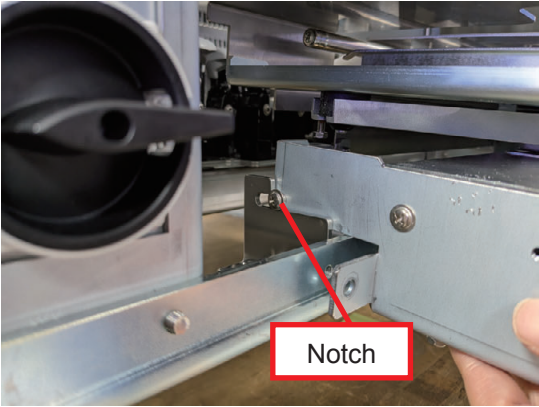

5.1.2 Removing the Printer Unit

Remove the right cover of the machine before the procedure. See 5.1.1 step 4.

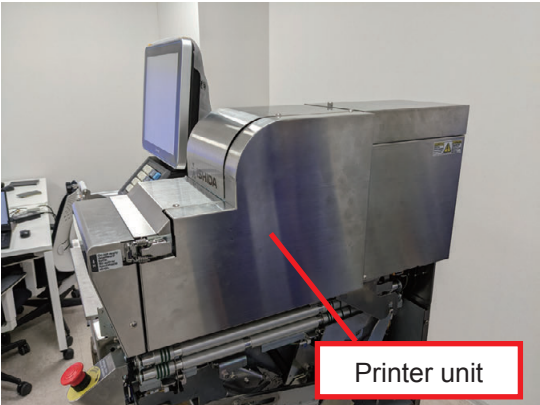

- 1. Remove 1 screw to remove the top cover.



- 2. Remove 6 screws to remove the side cover.

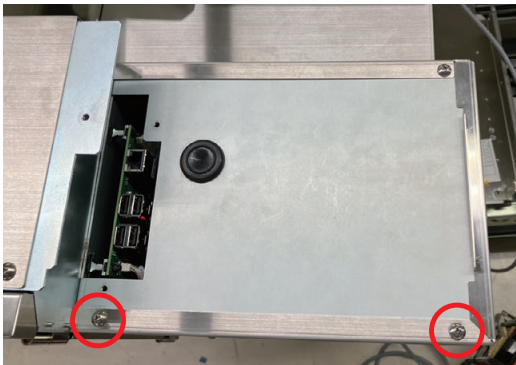

3. Open the cable holder and unplug the connector.

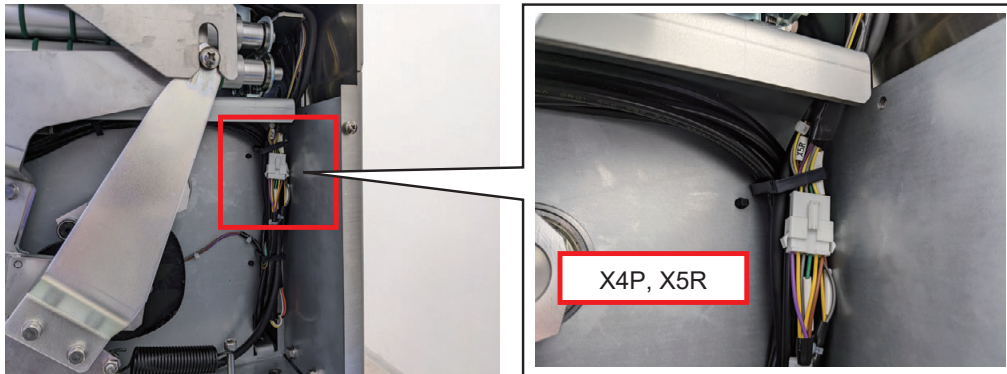

4. Unplug the connectors.

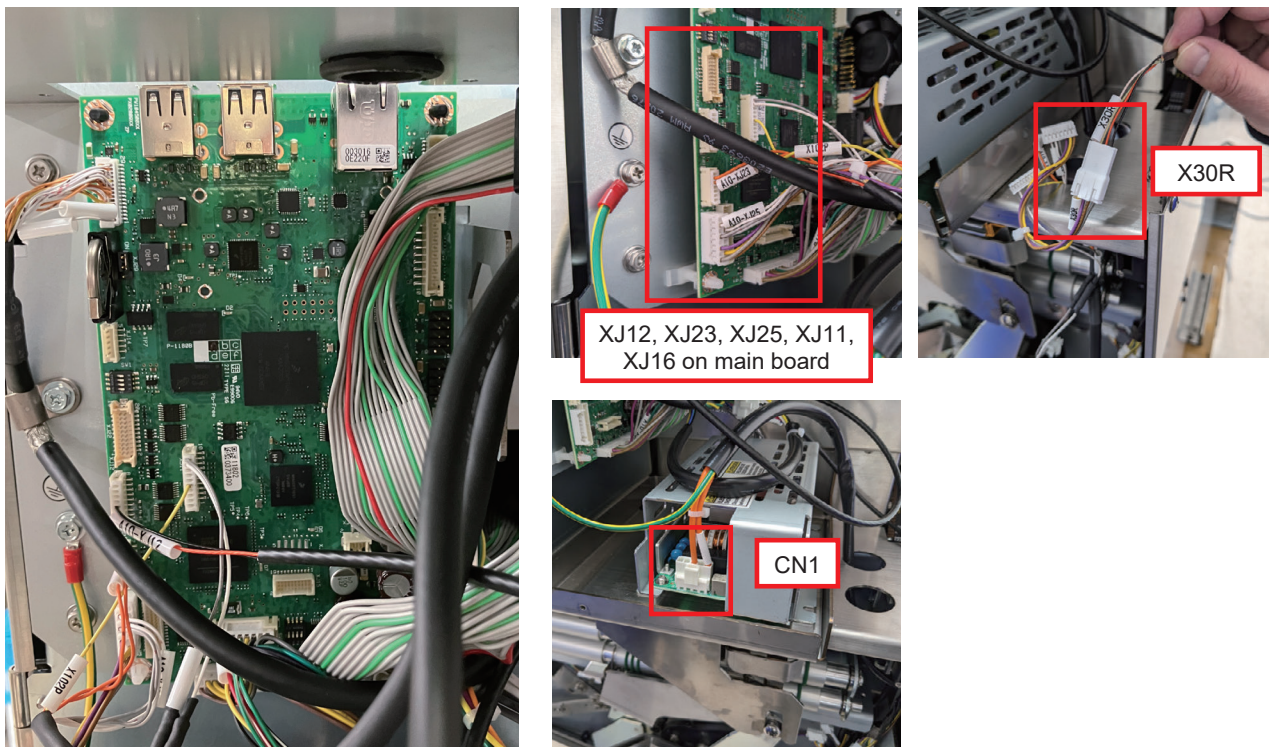

5. Remove 1 screw to remove the earth.

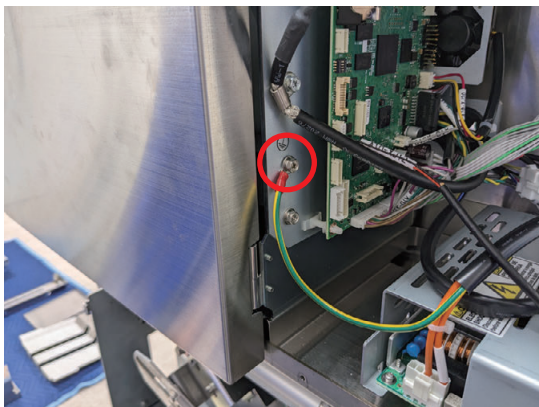

6. Remove 1 screw to unplug the connector.

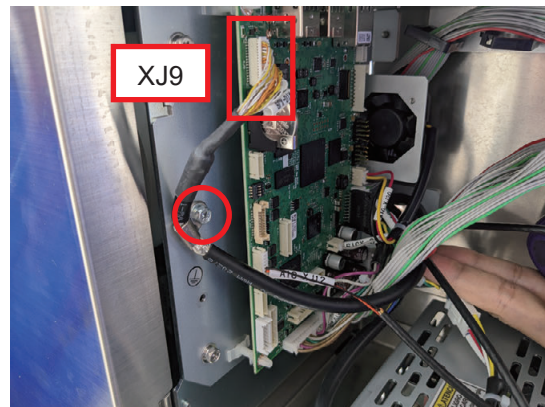

7. Remove 1 screw to detach the clamp.



8. Remove grommet to pull out the cables.

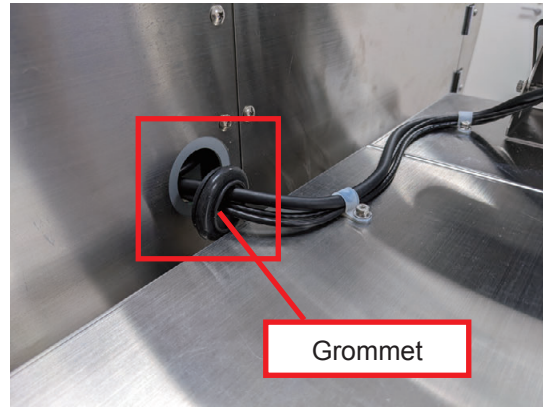

9. Remove 4 screws to remove the cover.



10. Remove 4 screws that fix the printer unit to the machine body.

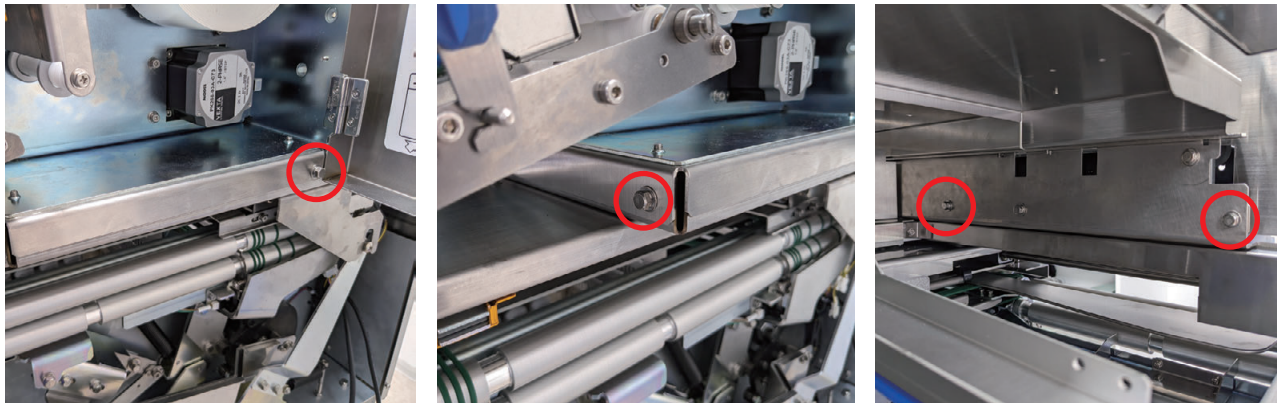

11. Pull out the printer unit from the machine body.

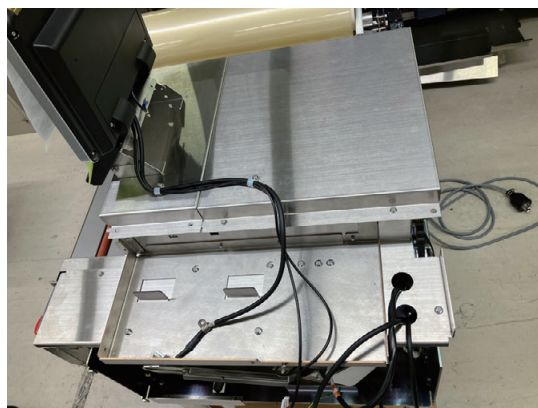

5.1.3 Removing the Operation Unit

Operation unit after being removed



1. Remove 1 screw to release the clamp.

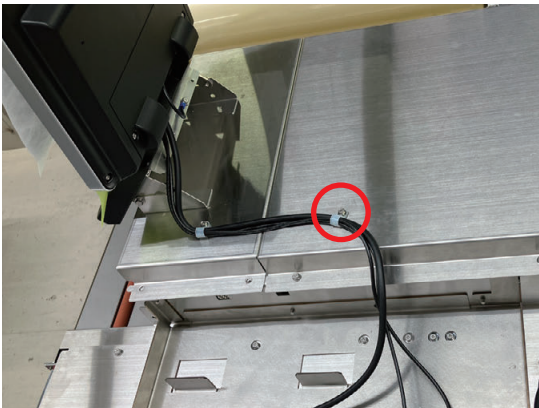

2. Remove 4 screws to remove the printer unit.

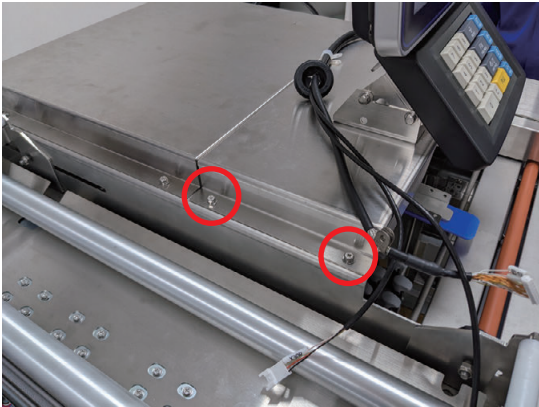

5.1.4 Removing the Wrapping Unit

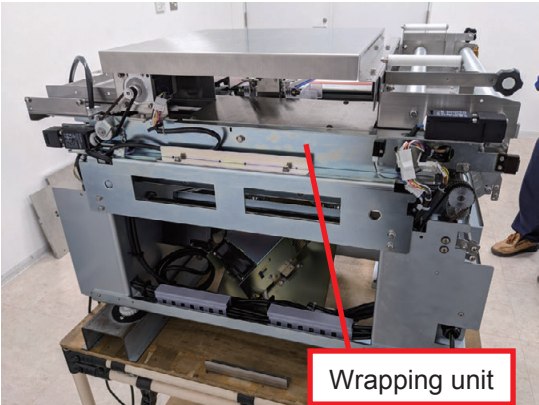

1. Remove 6 screws to remove the rear cover.



2. Remove 4 screw to remove the emergency stop switch.

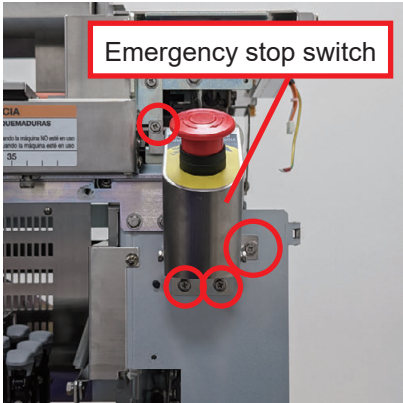

3. Loosen 4 screws to remove the cover.

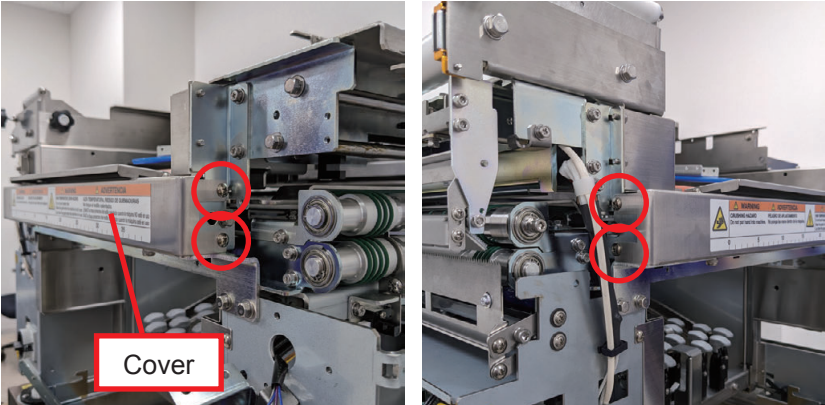

4. Remove 1 screw and open the cable holder.

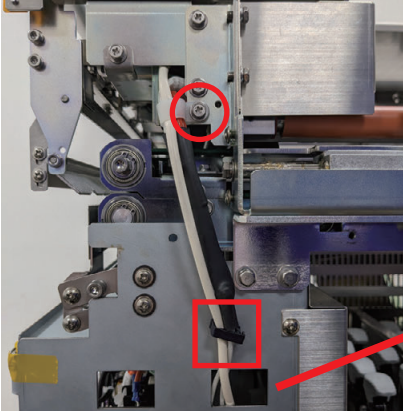

5. Pull out the cables and unplug the connectors.

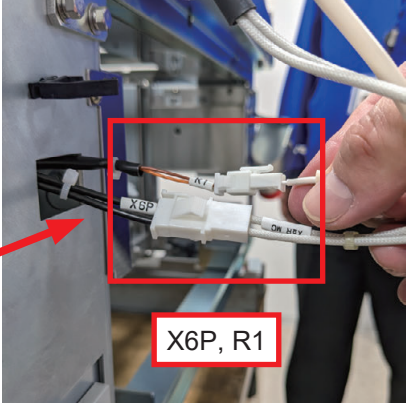

6. Unplug the connectors (inside the rear cover).

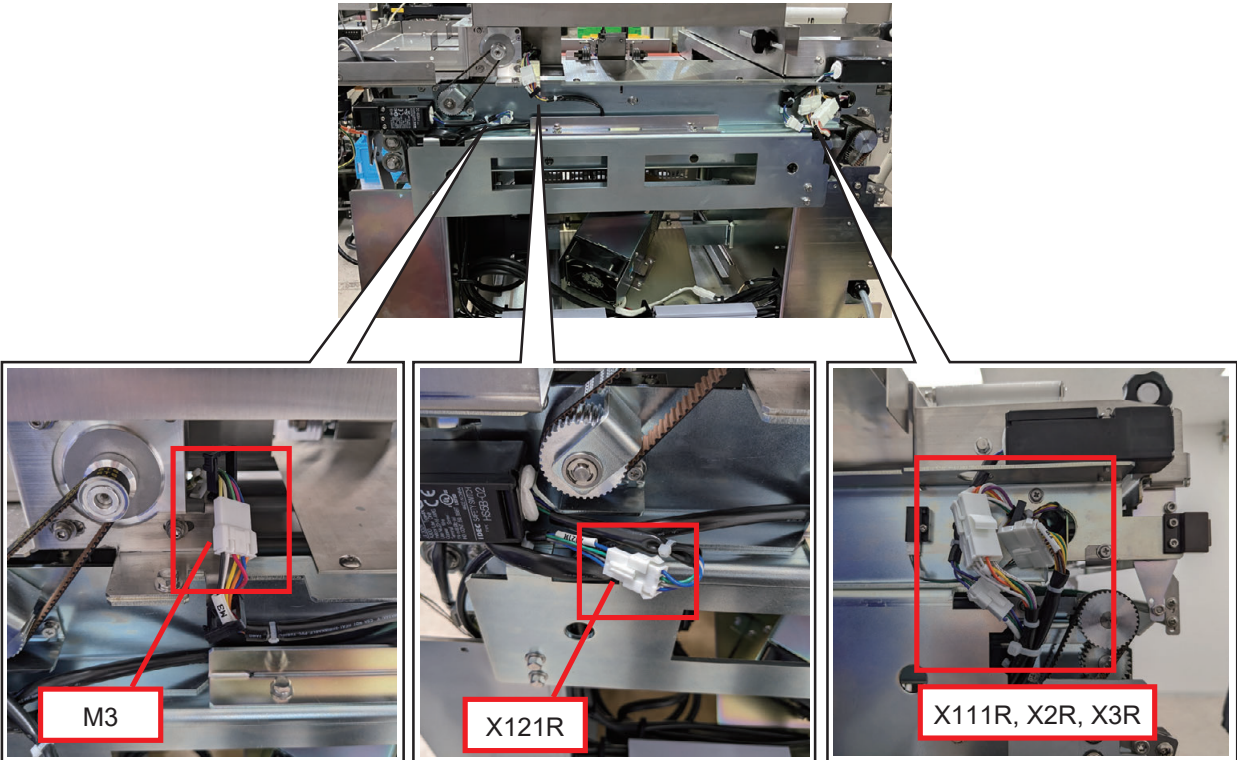

7. Pull the cables out of the holes to clear it.



8. Pull up the pin until it clicks and then make the whole wrapping unit slide a bit toward the near side.

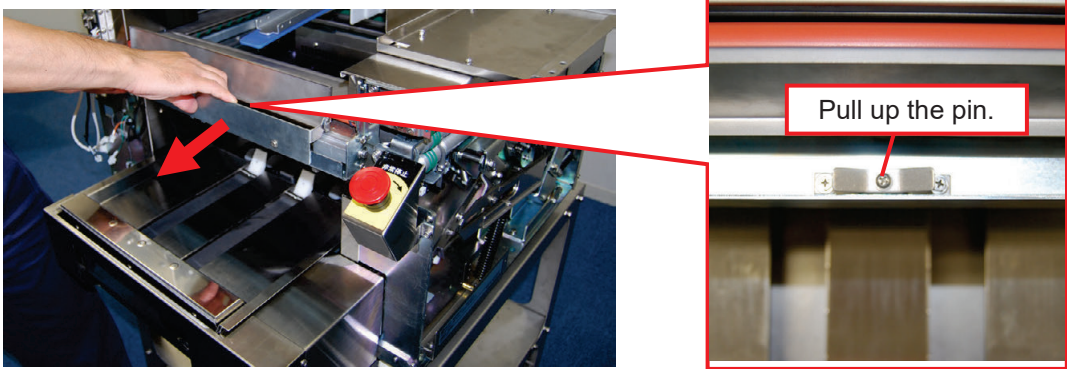

9. Check that the wrapping unit has slid properly. The wrapping unit has slid properly to the removable position if the notches on the front and back are released.

Front

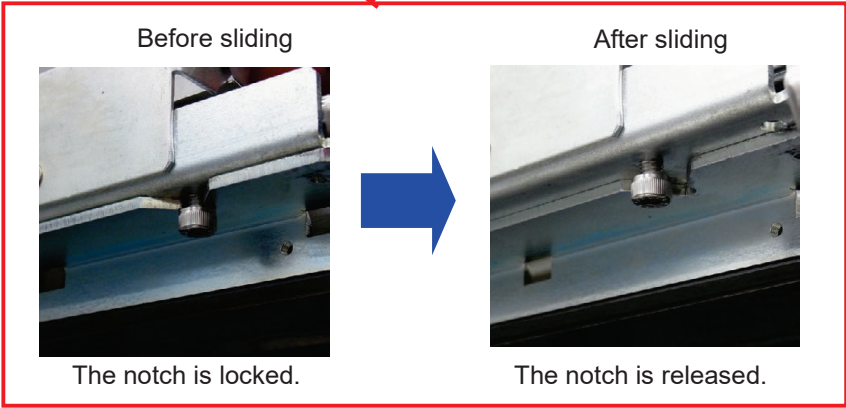
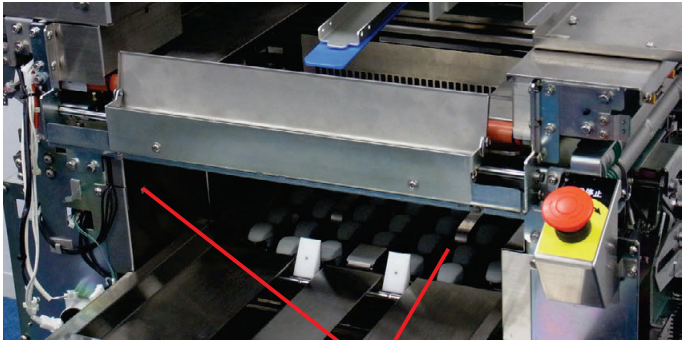

Back

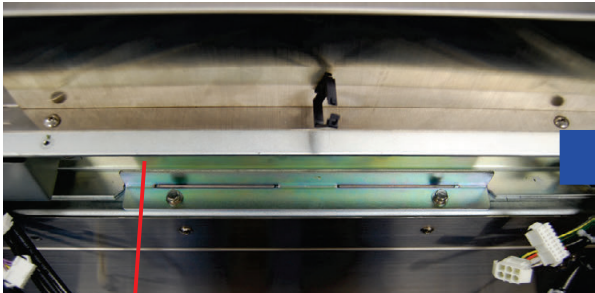

The notches are locked.

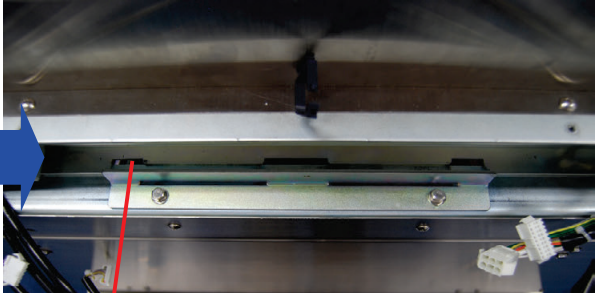

The notches are released.

10. Lift and remove the wrapping unit.
When carrying the unit, hold the outside frame portions. Do not hold the film arm portion on the left lateral.

CAUTION We recommend that the cutter blade be removed for safety. It might cause physical injury on removing the film conveying unit.

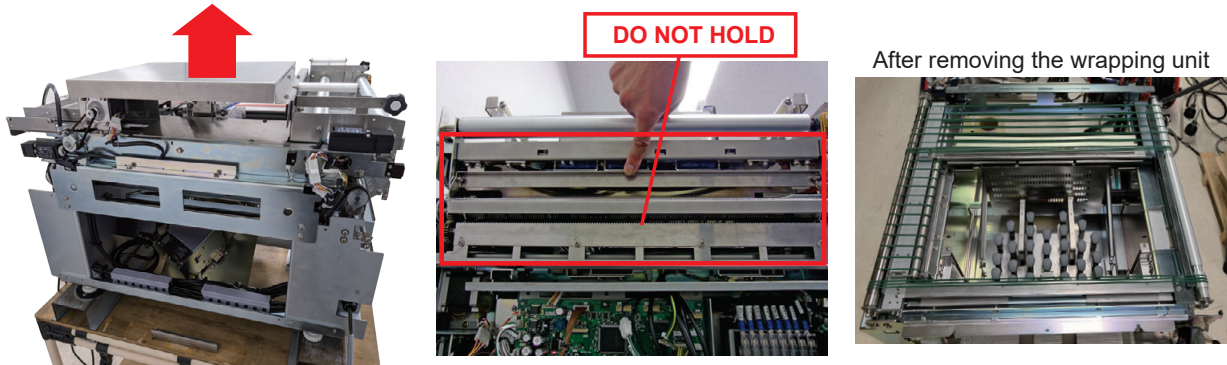

11. Rest the wrapping unit against some object or place it horizontally.

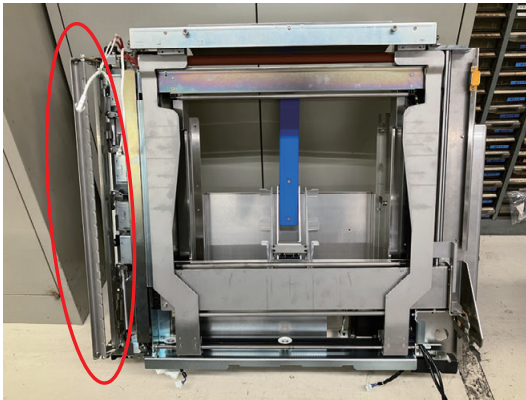

<Resting the unit against some object>
Rest the unit in the lateral direction against some other object.

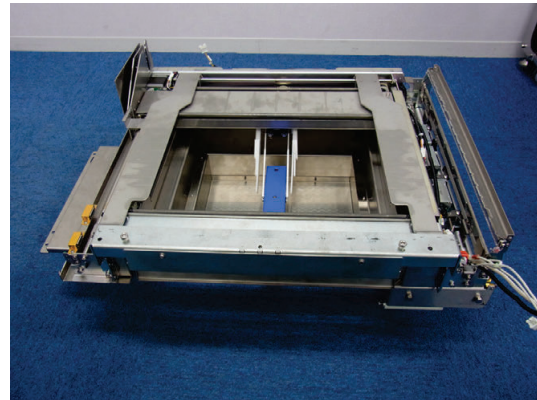

<Placing the unit horizontally>
Place the unit upside down.

NOTE: Do not place the unit with the left lateral film arm portion downside.

5.1.5 Dividing the Film Conveying Unit into Two

■ Removing the Film Conveying Unit

Procedure after removing the wrapping unit from the machine body is described below.



For procedures to disassemble the squeezing unit, refer to “Removing the Wrapping Unit.”

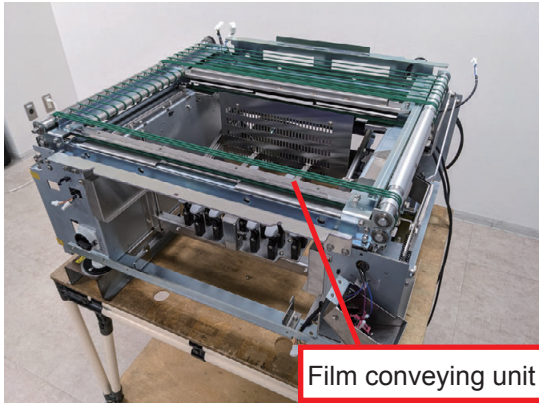

Film conveying unit after being removed

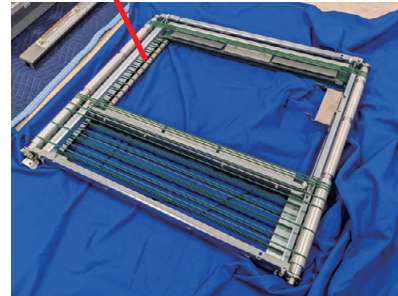

1. Remove 4 screws to remove the cutter blade.



CAUTION We recommend that the cutter blade be removed for safety. It might cause physical injury on removing the film conveying unit.

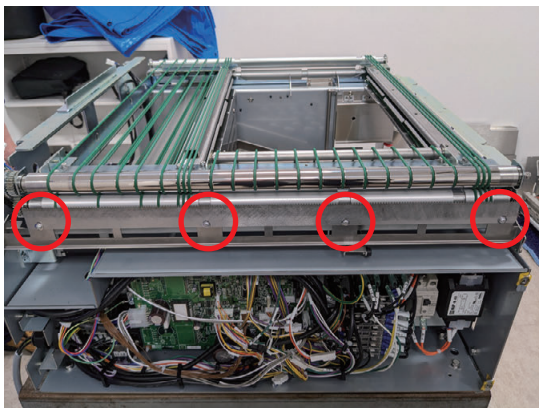

2. Remove 4 screws that fix the film conveying unit.



3. Remove the guide rails on the left and right sides.

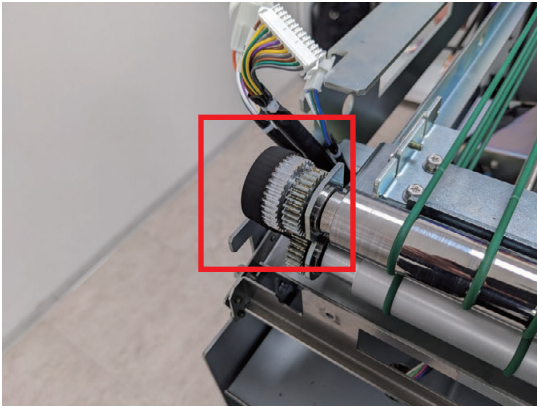

4. Remove the film conveying unit directly upward.

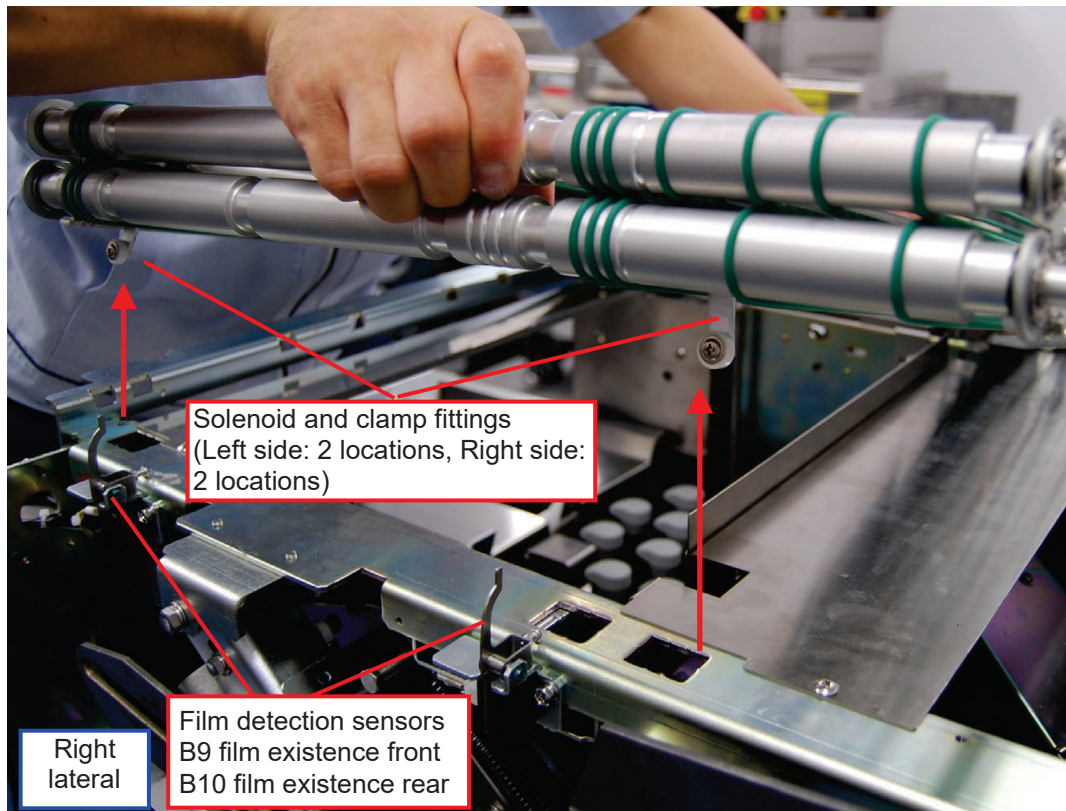

NOTE: In removing the film conveying unit, pay attention not to hit the film detection sensors (at 2 locations).

NOTE: In removing the film conveying unit, lift the unit directly upward so that it does not get stuck with the solenoid and clamp fittings (left side: 2 locations, right side: 2 locations).

5. Place the film conveying unit upside down.

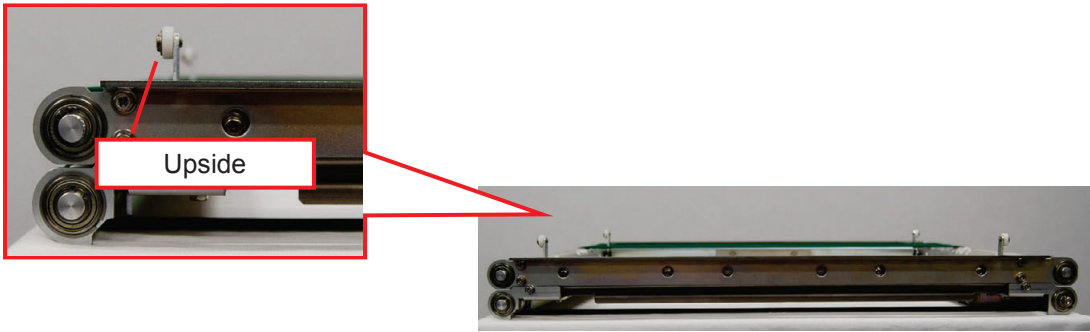

■ Dividing the Film Conveying Unit into Two

1. Remove the screws (4) at the four corners.

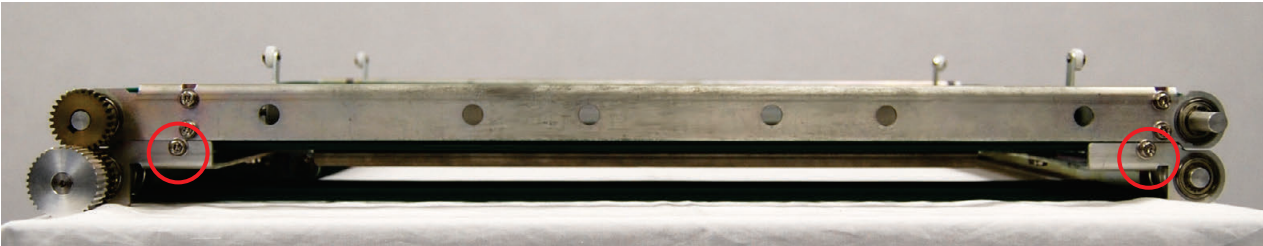
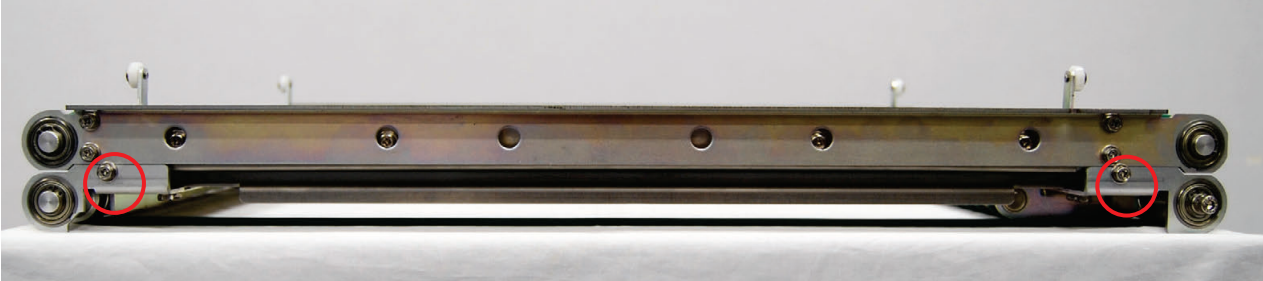

2. Lift the upper portion of the film conveying unit.

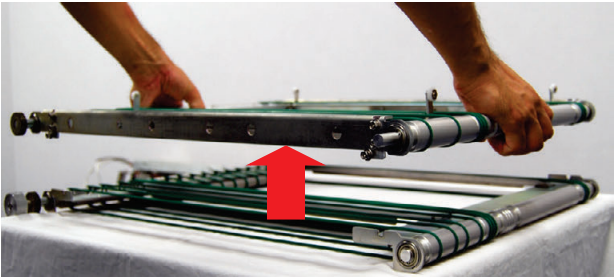

■ Replacing the round belts

- Mounting positions for roller round belts

Upper roller

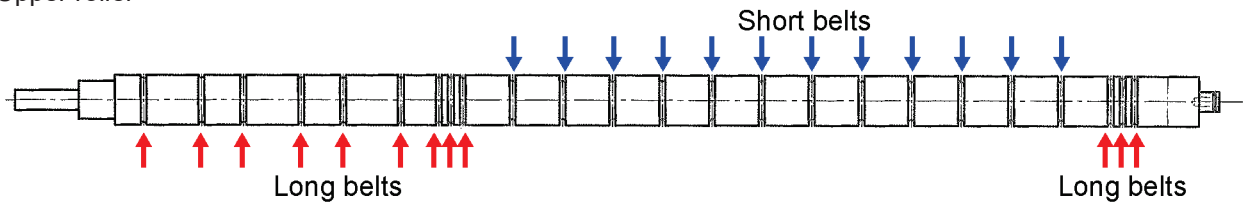

Lower roller



- Procedure to replace round belts

Length of round belts comes in two types: Long and short. Different replacement procedure is required for different length.

- For long round belts

1. Remove the round from the roller for replacement.

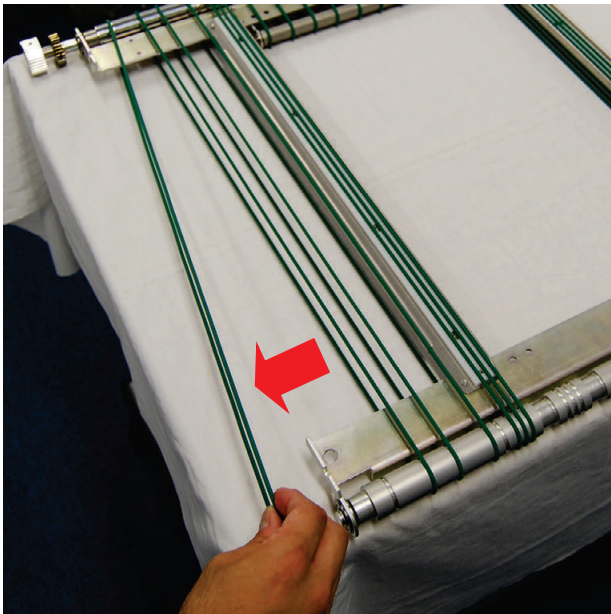

- For short round belts

1. Remove the outside long belts (3).
2. Remove the screws (2) on the short belt side to remove one side of the rail.

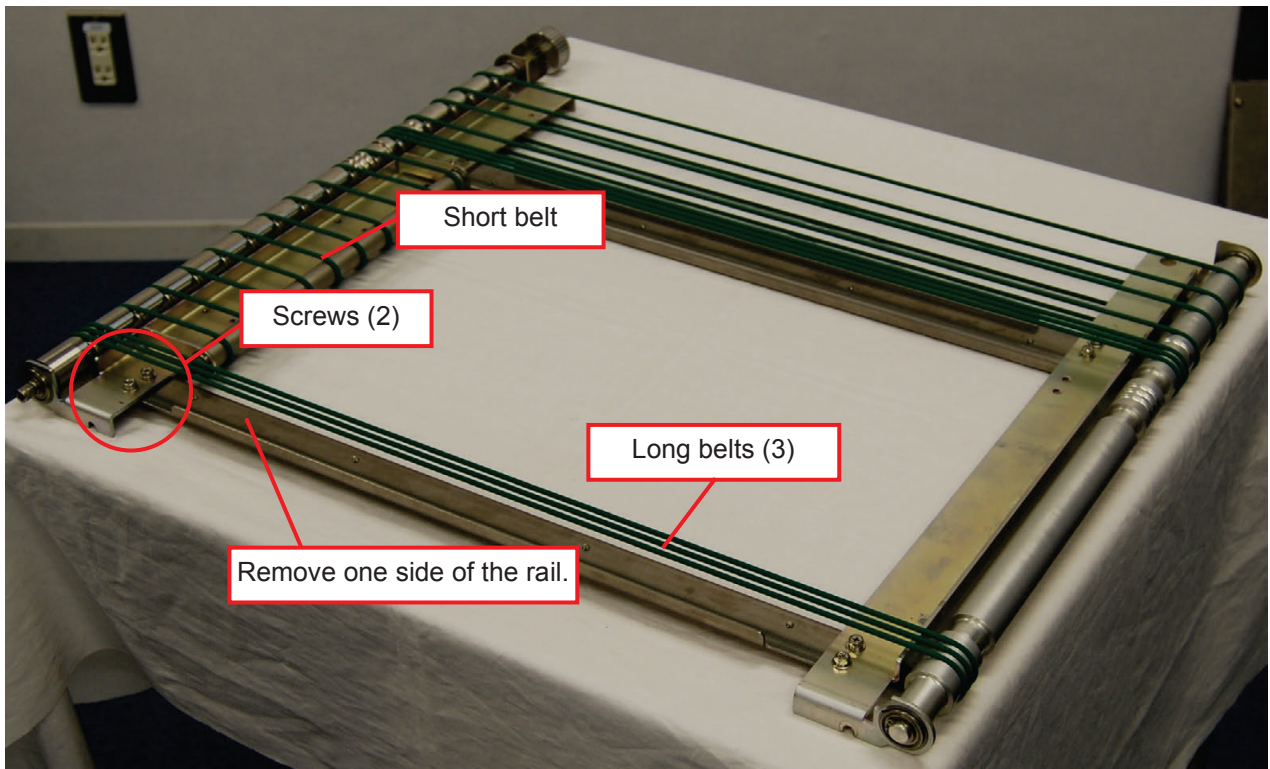

3. Remove screws (2) to remove one side of the roller of the short round belts.

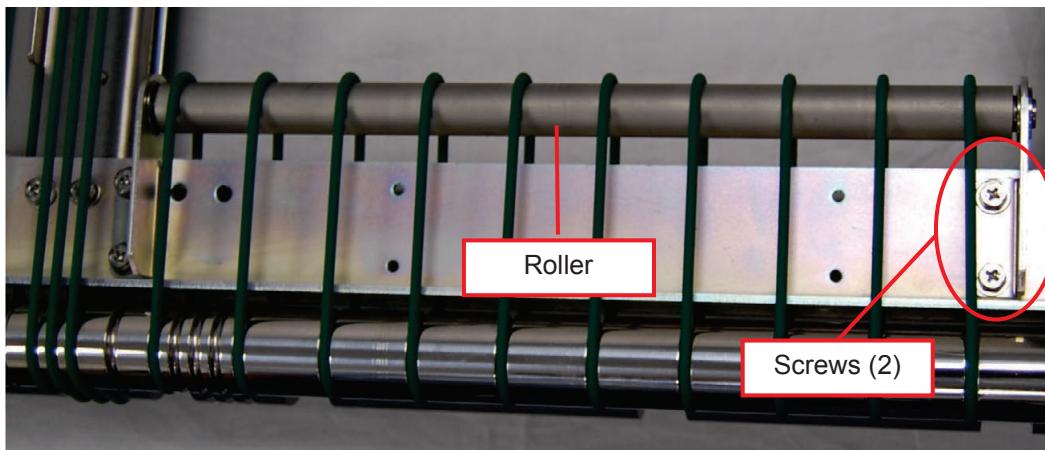

4. Replace the short round belts.

• Assembly after replacing the short belts

Assembly procedure follows in the reverse direction of the procedure for dividing the unit into two. If assembly is conducted with the unit lying flat, the film conveying unit may be deformed into a parallelogram shape.

To prevent this from happening, follow the procedure described below.

1. Tighten the screws (2) on the removed side of the roller.
Adjust the mounting position by moving the bracket closer to the roller.

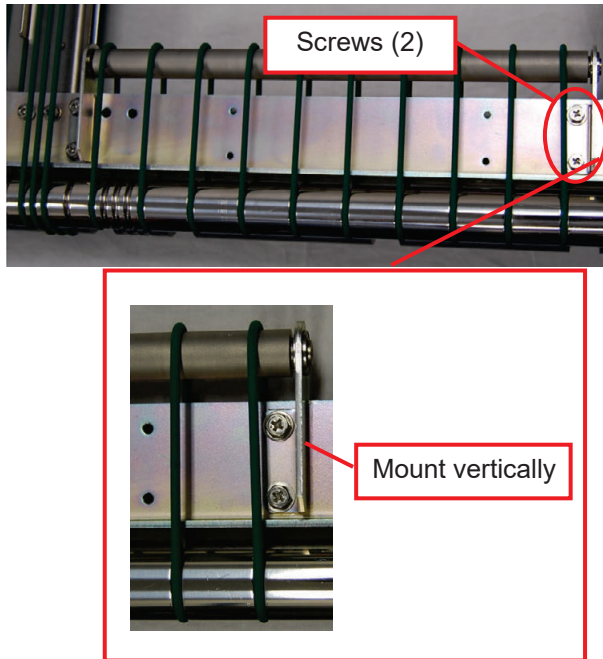

2. Temporarily tighten the screws (2) of the removed rail.
Adjust the mounting position by bringing the frame inward.

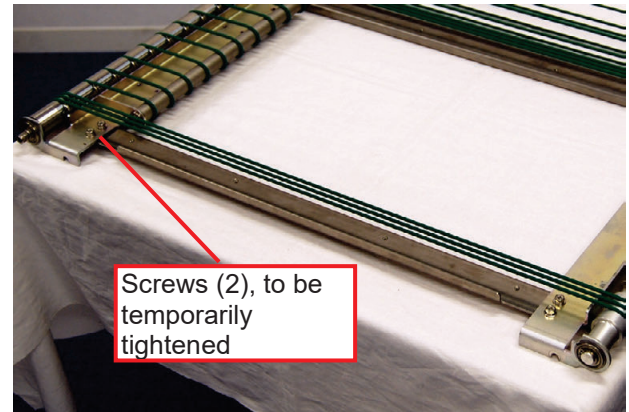

3. Adjust the upper and lower film conveying units to the proper position.

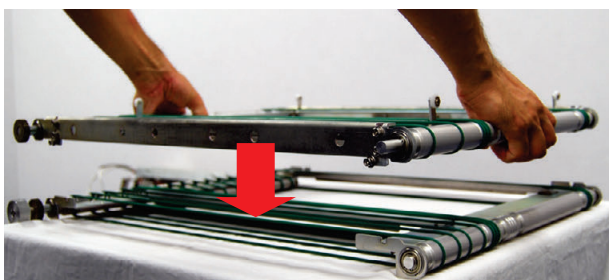

4. Firmly tighten the rail screws (2) that have been temporarily tightened with the unit.



5. Tighten the screws at the four corners to fix the upper and lower film conveying units.



■ Adjust clamp plate mounting position

When the clamp plate of the film conveying unit is removed or replaced, the clamp plate must be fixed in a proper position.

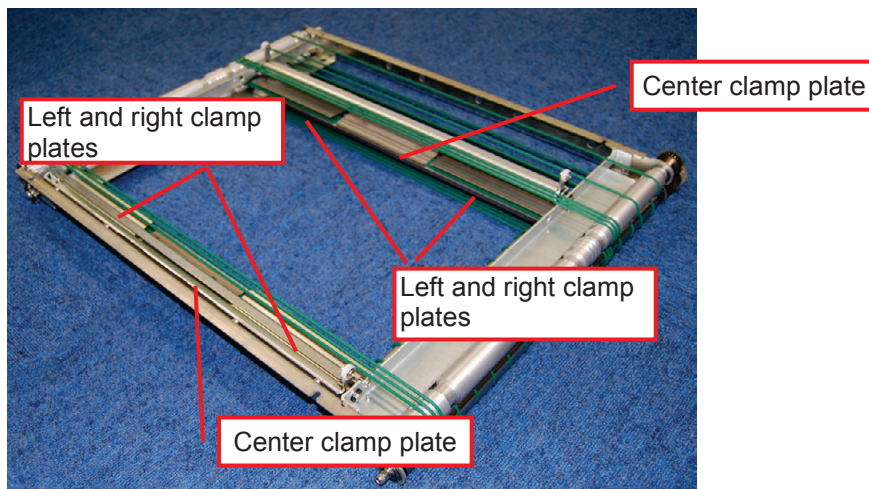

● Points of caution in mounting the clamp plate.

- Mount the clamp plate apart as much as possible from the round belts on the side of catching film.

Maintain space between the clamp plate and the round belts as much as possible. If space is insufficient, the round belts may run off the clamp plate and get stuck on the plate, making it impossible for the belts to return to their original positions

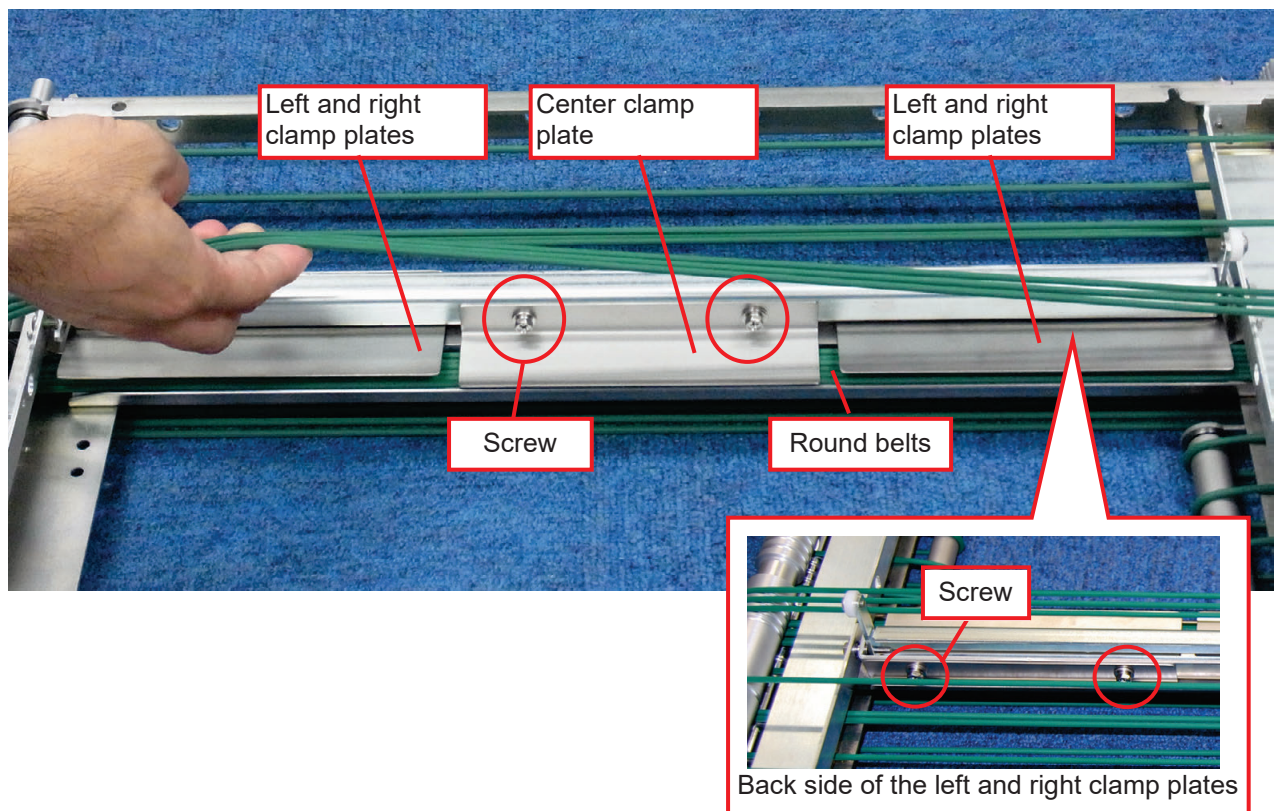

In the case shown in the photograph below, mount the clamp plates at a lifted position shown in the direction of arrows as much as possible.

Fix each clamp plate with screws (2). Fix the left and right clamp plates at the back with screws (2).

NOTE: This picture shows the unit removed, turned upside down and adjusted.

<LL type>

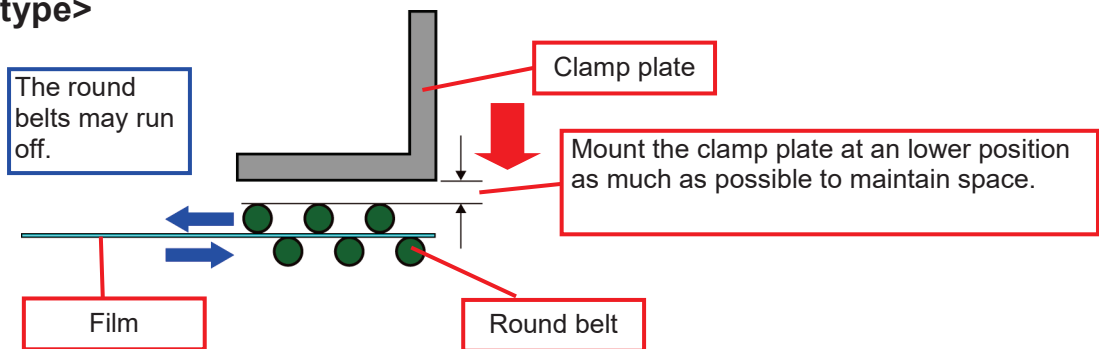

<L type>

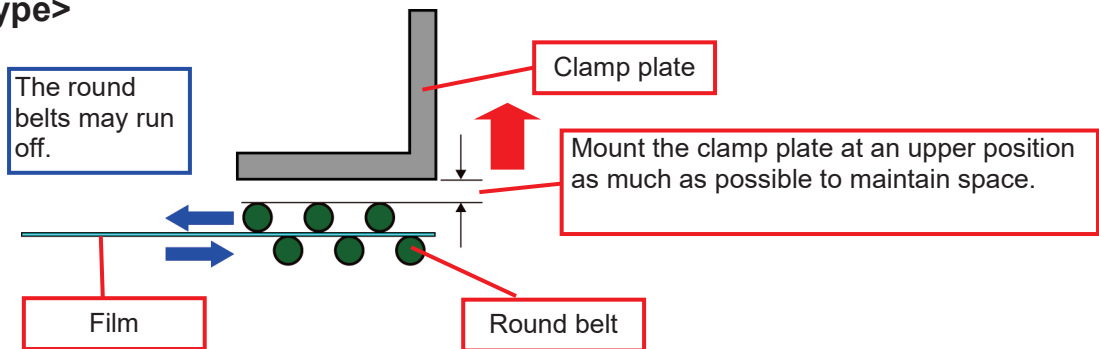

- Mount the clamp plate horizontally. Tighten screws keeping the clamp plate in a position as shown in below. Otherwise, film cannot be caught uniformly.

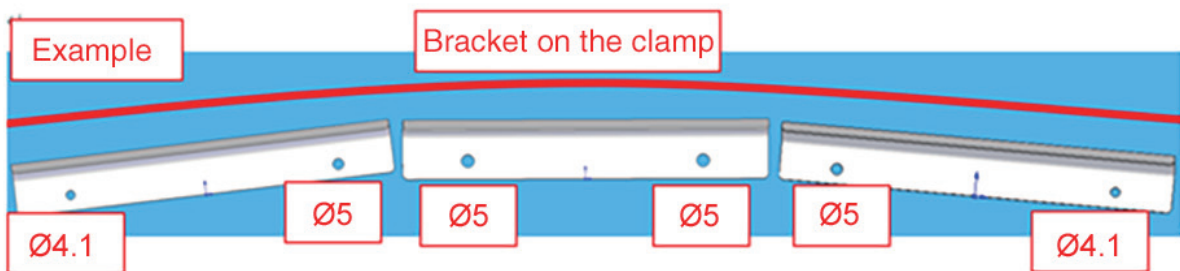

The LL type is reinforced because the clamping force is increased as the solenoid is strengthened.

■ Mounting the Film Conveying Unit

1. Place the film conveying unit directly from the above.

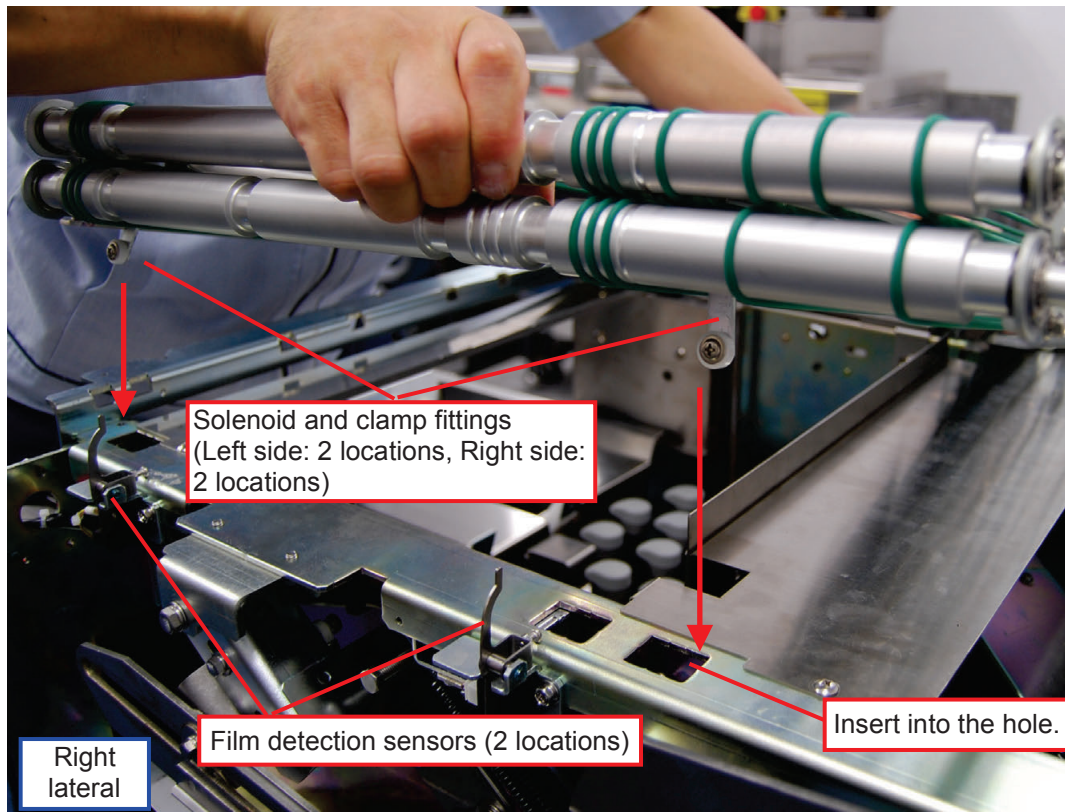

NOTE: When mounting the film conveying unit, pay attention not to hit the film detection sensors (at 2 locations).

NOTE: When mounting the film conveying unit, insert the solenoid and clamp fittings (left side: 2 locations, right side: 2 locations) into the solenoid holes.

2. Pull out the film conveying unit into a full forward condition. (Close up the idle gap created in the front.)
3. Tighten the screws (4) at the four corners to fix the film conveying unit.

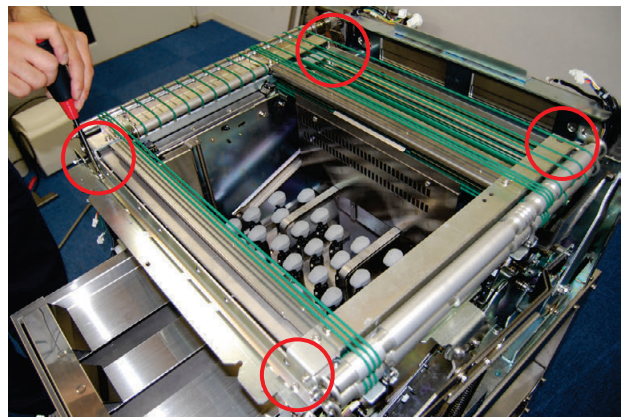
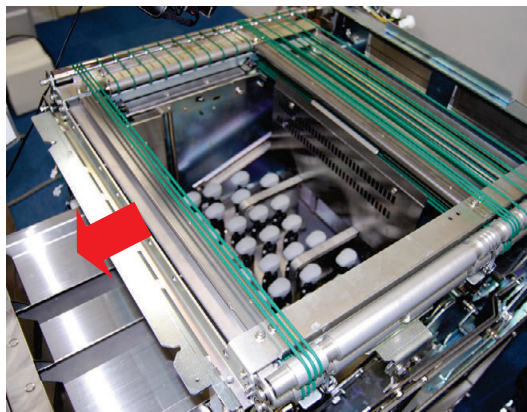

For LL type: confirm that there is no gap between the anti-deflection bolt of the feeder unit and the frame.

4. Place the back side wire harness in the left- and right-side notches, respectively.

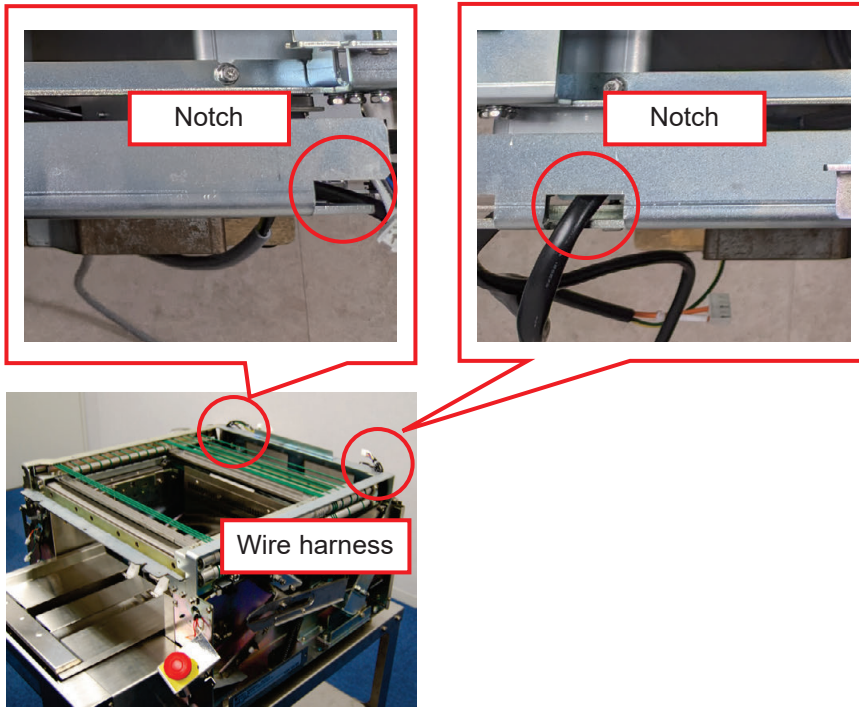

5. Mount the removed belt at the left side back again to the original roller.
6. Mount the wrapping unit, printer unit, and operation unit.

■ Checking the clamp

Check whether the clamp can catch film. Test run and check the clamp by using a piece of paper. Prepare a long and thin piece of paper.

1. Touch the [UNIT ACTION] in the Maintenance Adjustment Mode.
2. Select [ALL CLAMPS] as required, before execution. The clamp starts the open-close operation.

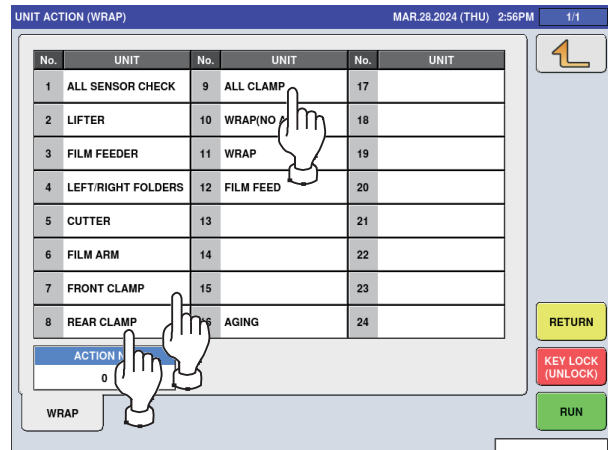
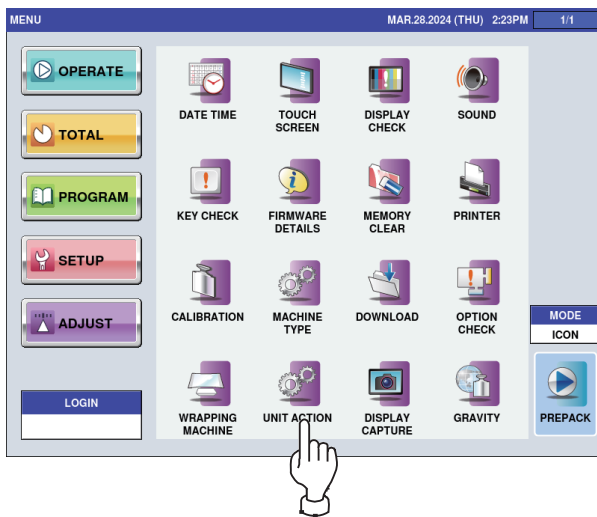

3. Insert the paper when the clamp is open. (The photograph shows the center clamp.)

Check the following two items.

- When the paper is caught, pull it and check whether the solenoid is located at a position where maximum resistance is given. For procedure to adjust the solenoid, see the next page.
- Check that resistance is uniformly given over the whole clamp width. When a thin piece of paper is used, slide it left and right for checking.

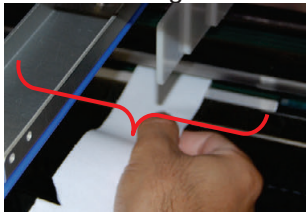

If resistance is not uniform, clamp is not fixed horizontally. Mount the clamp horizontally again.

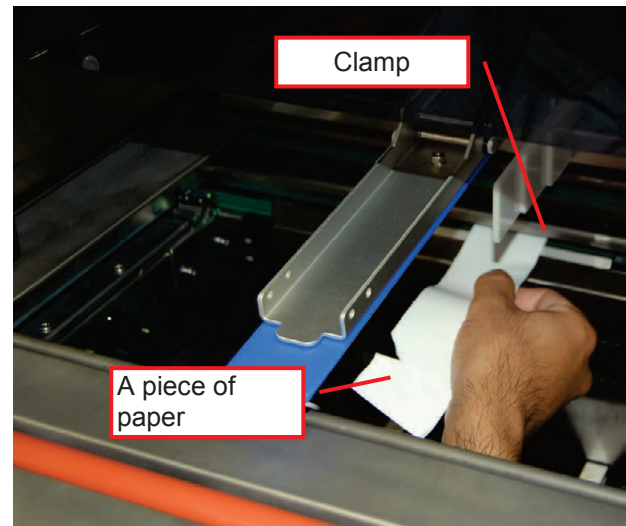

- Conduct similar checks on other clamps by inserting a piece of paper. (Also check the clamps on the other side.)

The factory adjusts as follows. (Place a 25 mm wide post-it between the clamps and measure the force. Force is measured at 3 locations per clamp.)

LL type	Center clamp	Center: 10.0 N or more Both edges: 7.0 N or more
	Left / Right clamp	Center: 7.0 N or more Both edges: 3.5 N or more
L type	Center clamp	Center: 6.0 N or more Both edges: 5.0 N or more
	Left / Right clamp	Center: 2.5 N or more Both edges: 1.5 N or more

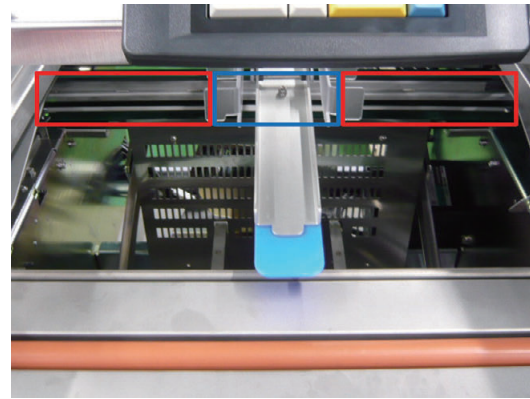
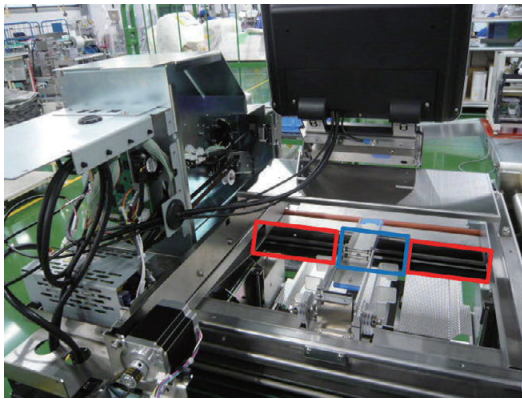

• Adjusting clamp solenoid

Adjust the solenoids that open and close the clamps. Four solenoids are used to open and close the front and back clamps.

Screw holes are elongated so that position is adjusted with screws (2 screws for each solenoid). Solenoids are associated with each clamp as shown below.

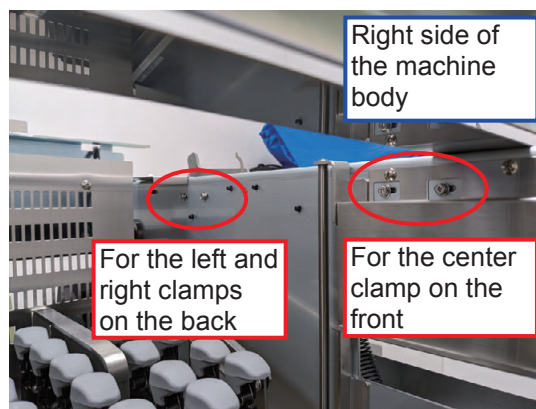
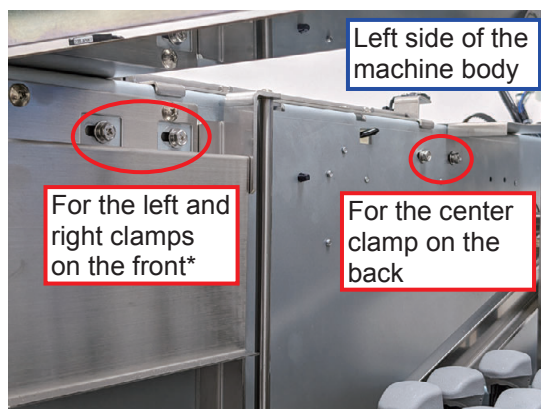

5.1.6 Point for Unit Assembly

Carry out assembly basically in the reverse direction of disassembly. Only main points are described below.

- **In mounting the wrapping unit: Coupling arms**

In placing the wrapping unit on the machine body, couple the rearsqueezing arm and pusher arm up and down.

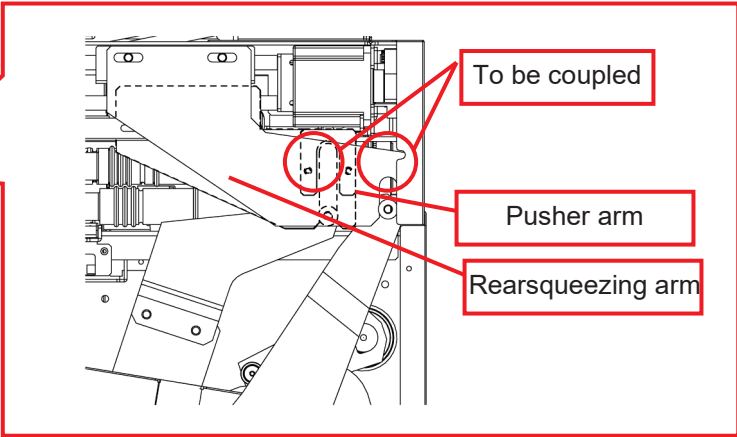

- **Push the cable into the rail.**
Push the power cable into the rail.

- **After mounting the operation unit: Storing cable**

After mounting the operation unit, store the cable in the rails under the right and left laterals.

LL type



Store the cable inside of the machine.

L type

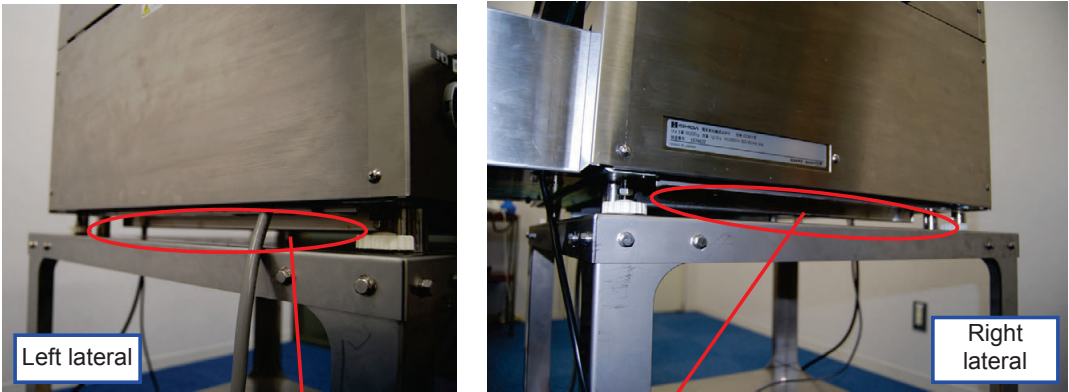

Store the cable in the rail.

5.2 Adjustment

5.2.1 Adjusting Lift Height

Adjust the lift height with 4 mm hexagonal nuts. Prepare two 4 mm hexagonal nuts

1. Release the lock lever to remove the lift head.
2. Remove screws (4) on the lower side to remove the cover.

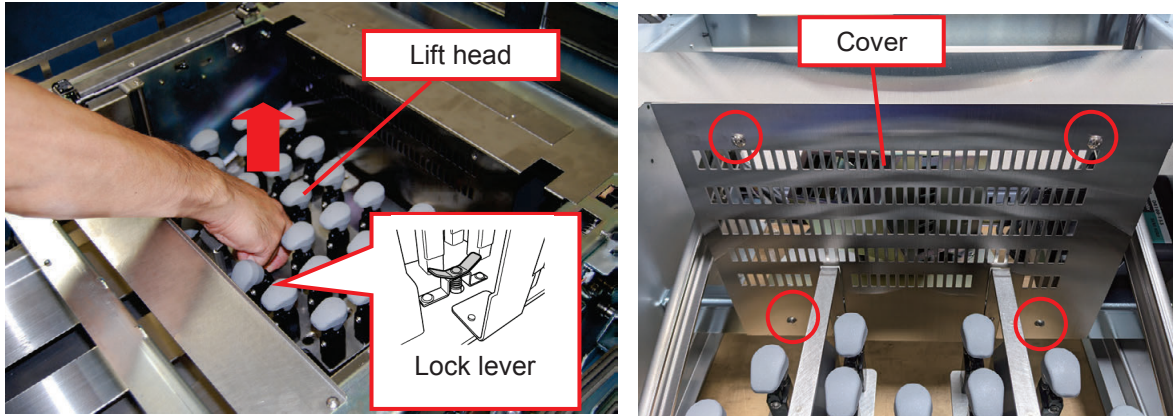

3. Remove screws (2) to remove the upper cover.

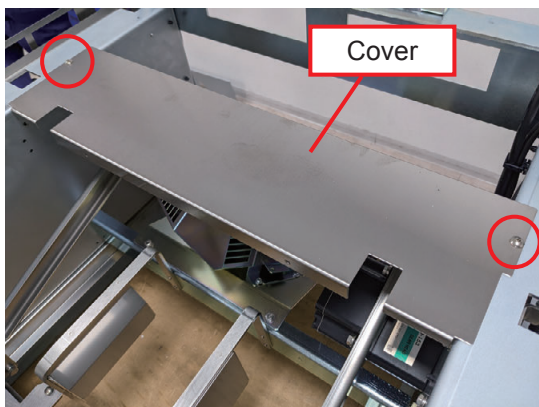

4. Pull out the film conveying unit into a full forward condition. (Close up the idle gap created in the front.)

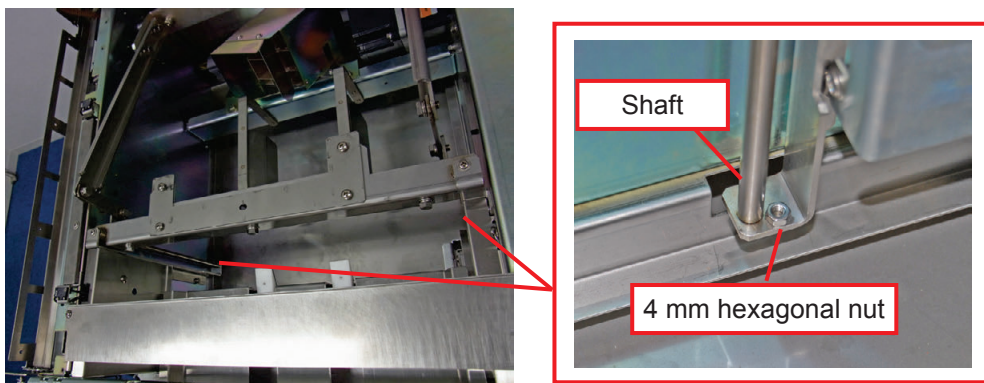

5. Lower the lift to the lowest position resting on the hexagonal nut. (Conduct adjustment in this position.)
6. Loosen hexagonal bolts on both sides (2 on the left and 2 on the right) to adjust height

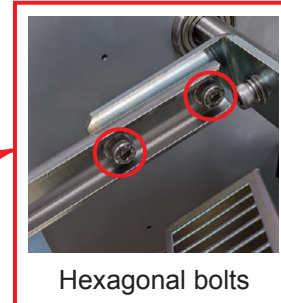
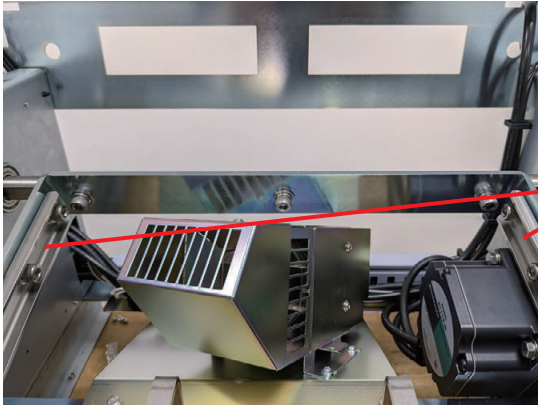

7. Remove the hexagonal nuts (2) placed under the shaft and set the lift head.
8. Check that the gap between the bottom of the shaft and the frame is 1 – 3 mm seen from under the machine body when the shaft is lowered in the lowest position.

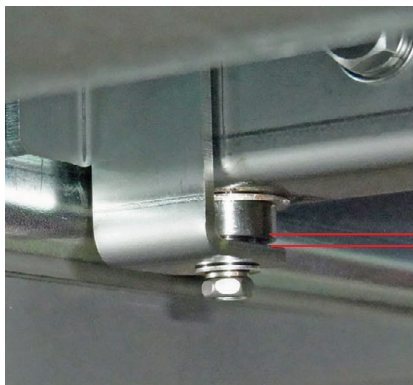
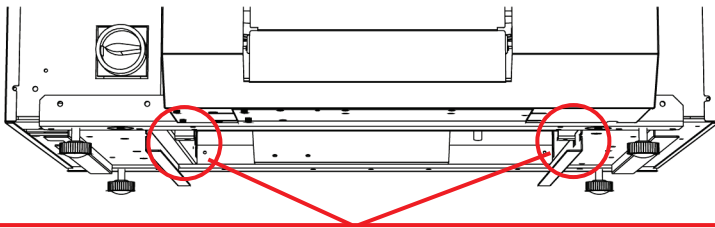

The gap between the shaft bottom and the frame is 1 – 3 mm.

10. If the gap is not 1 – 3 mm, repeat the above procedure 5 through 9 to adjust height.
If the gap still does not fall in the range of 1 – 3 mm, loosen the hexagonal bolts (3) in the back to adjust height in a similar way.



NOTE: The check on the lift can be conducted by executing [Unit Operation] [Lift] in the Maintenance Adjustment Mode.
In this case, check that the top end of the lift hits on the shaft. If you hear a sound when the lift goes up, the situation is OK.

5.2.2 Adjusting the Film Arm

Film arm adjustment includes the following items.

- Operating range adjustment for the film arm in the lateral direction (inside - outside) (adjusted with screws)
- Roller position adjustment for the film arm (adjusted with nuts)
- Film holder position adjustment (adjusted with screws)

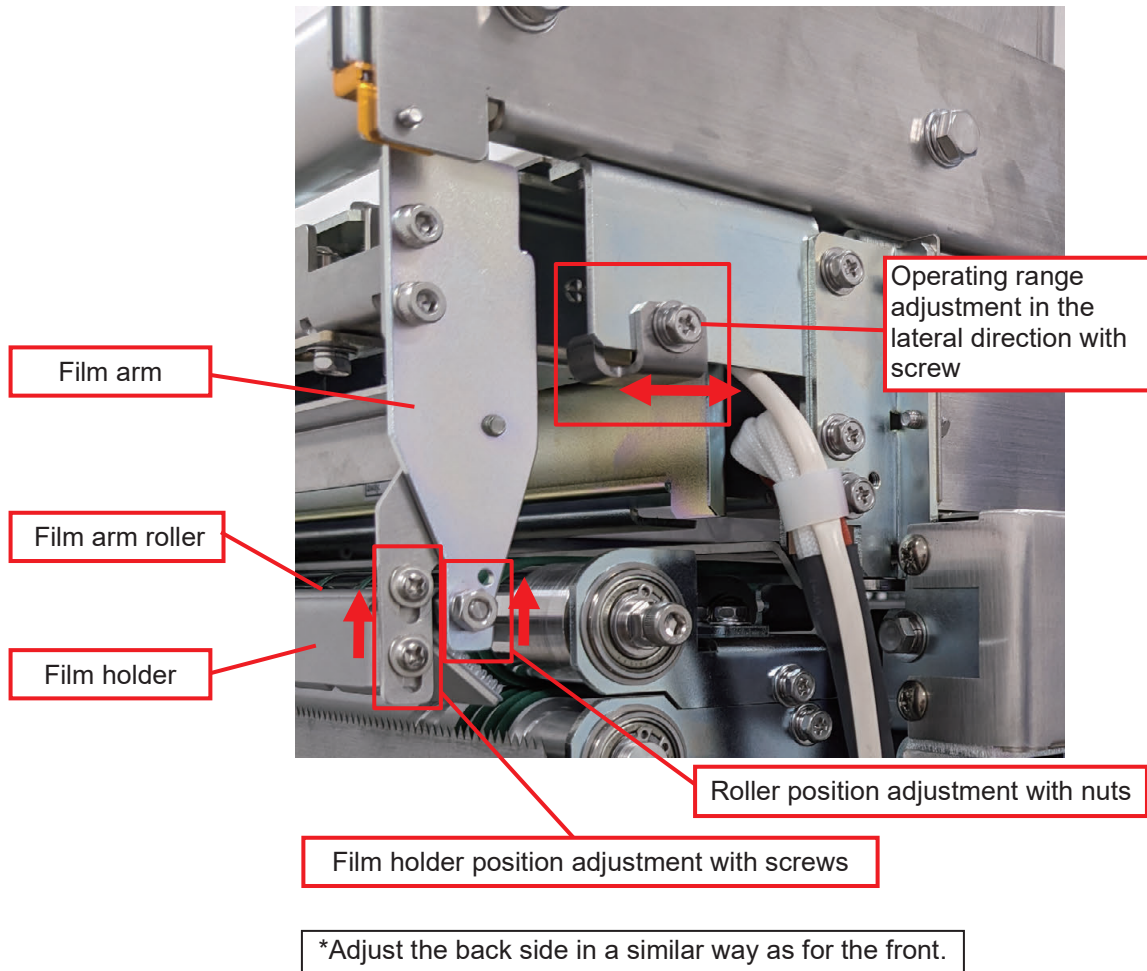

Follow the procedure [1] through [7] described below to adjust the film arm.

[1] Checking the film arm position

Check that the film arm is in the proper position before adjusting the film arm.

- Check that the film holder is parallel with the roller.
Check the parallelism from the near side to the back side.

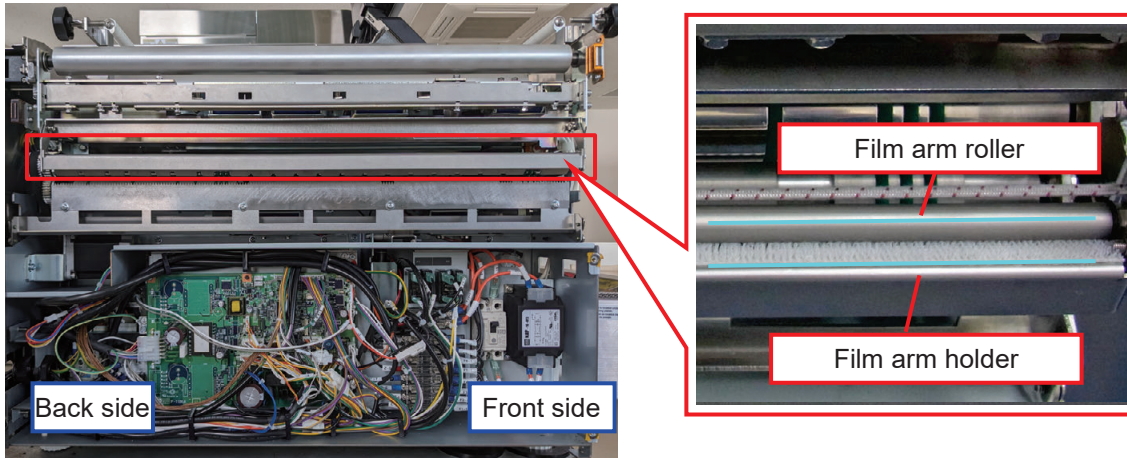

- Check that the film arm is not slipped in the horizontal direction.
Check that the belt runs on the concave portion of the film arm.

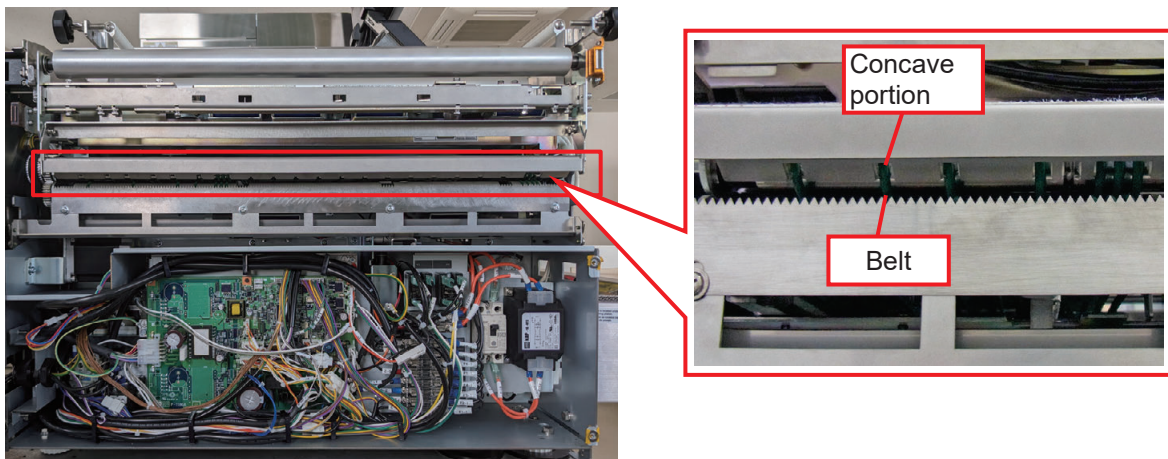

If the belt does not run on the concave portion, conduct adjustment in the following manner.

- 1. Pull out the film conveying unit into a full forward condition. (Close up the idle gap created in the front.)

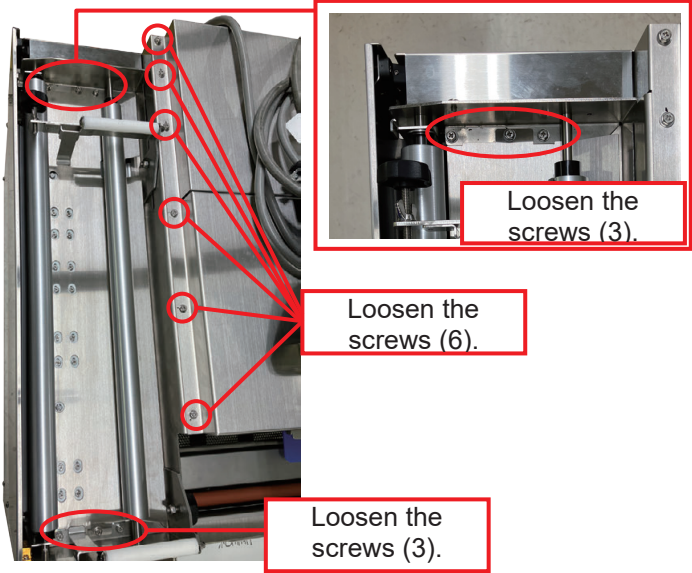

- 2. Move the entire film arm to adjust the position so that the belt runs on the concave portion.

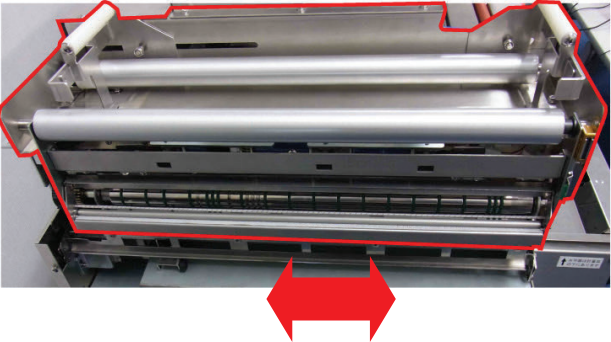

- 3. Check that the film arm roller is parallel with the conveying unit roller.

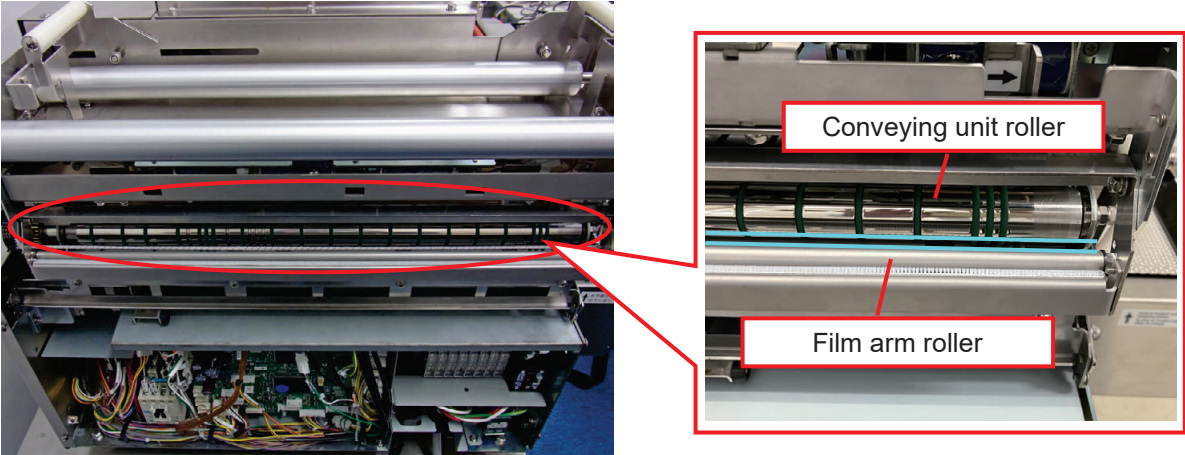

[2] Adjusting inside stopper position

Set the operating range of the film arm in the lateral direction. Set the inside limit position as follows:

1. Loosen the screw of the inside stopper (front side).
2. Push the film arm until the tip of the film arm touches the film pull-out roller. Fix the inside stopper in this position.

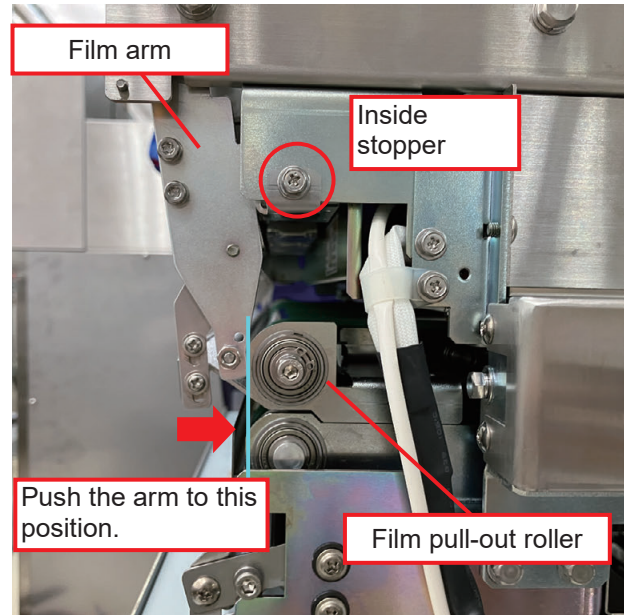
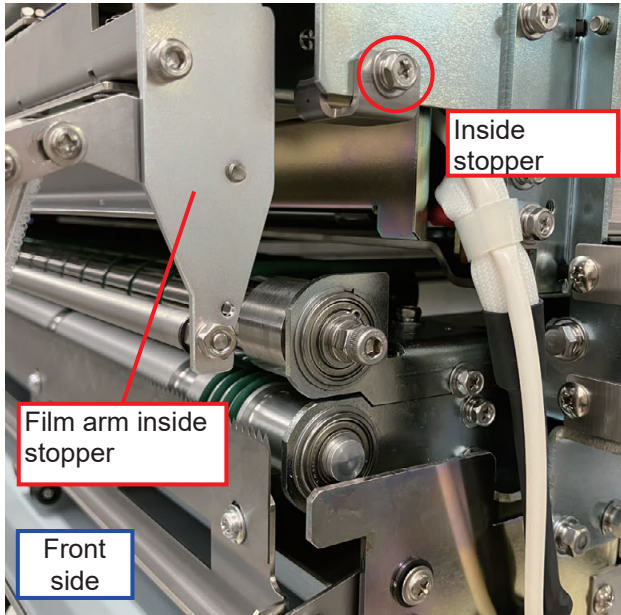

3. Adjust the inside stopper in the back in a similar procedure as for the near side.

4. Check that the film arm roller is in parallel with the film pull-out roller. Check parallelism while the film arm is being pushed into the farthest inside at its "Near Side, Center, and Back Side" positions.

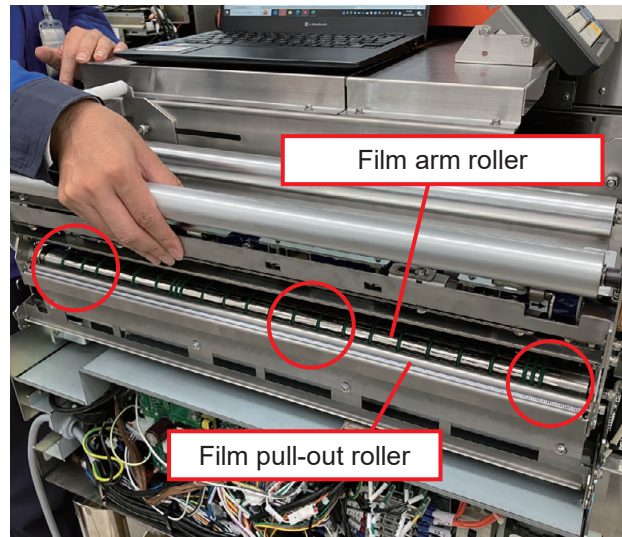
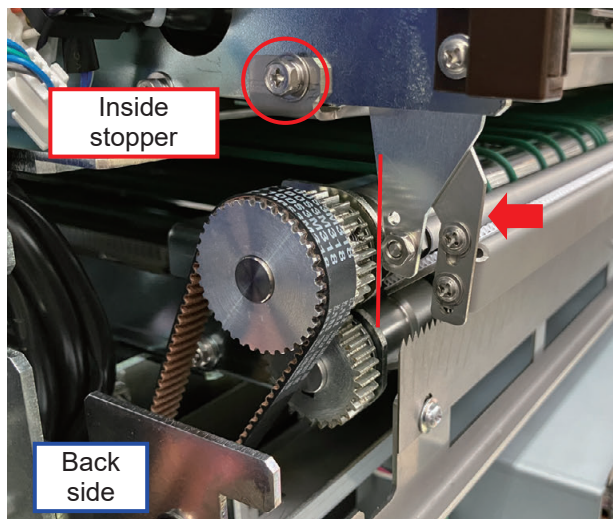

[3] Adjusting film arm roller position

- 1. Set the film arm roller position at the top.

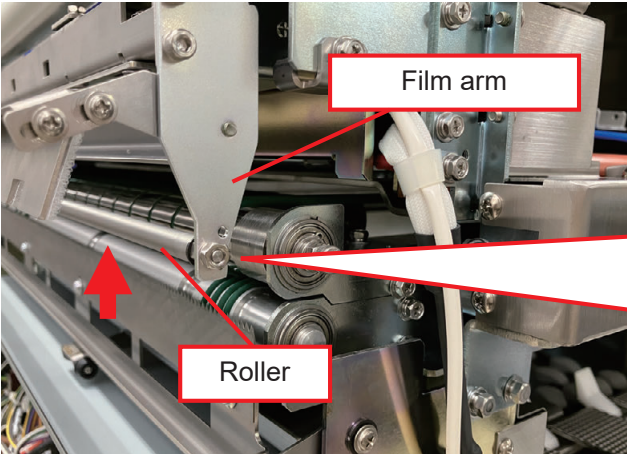

Loosen the outside nut and fix it at the uppermost position of the elongate hole (the roller is at the top position).

Fix the nut at the top position of the elongate hole.

The diagram shows a blue hexagonal nut with a red arrow pointing upwards, indicating the direction to move the nut to the top position of the elongate hole.

NOTE: Pay attention for the case where the spring washer gets caught in the elongate hole, preventing the nut from moving to the top of the hole.

- 2. Similarly, set the roller position on the other side at the top.

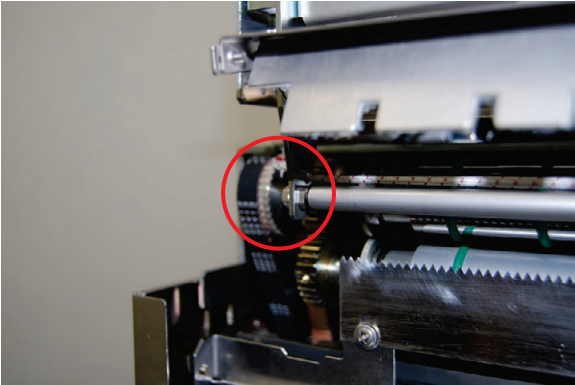

- 3. Check that the roller revolves smoothly while the film holder is lifted.

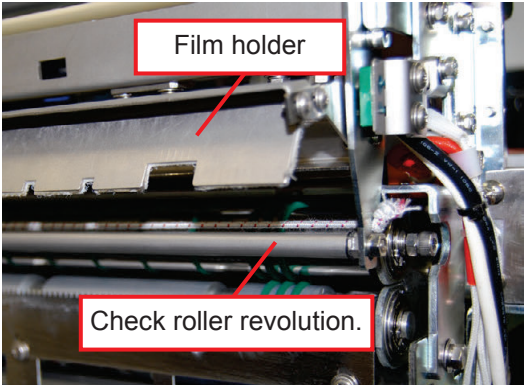

[4] Adjusting film holder position

1. Upper the film holder (set it at the origin position). Adjust the position in this condition and fix the holder with screws (2).

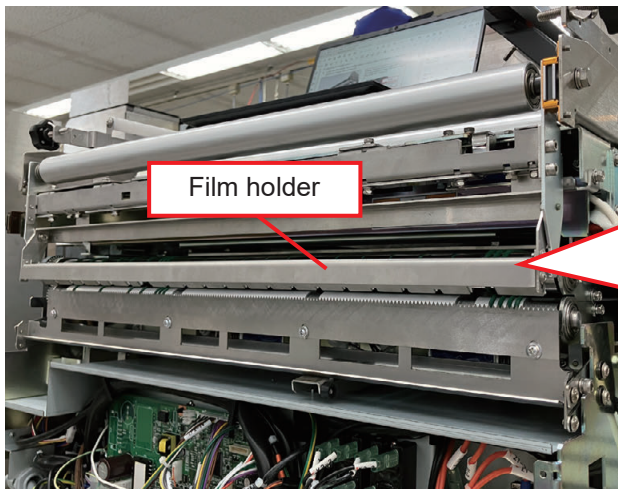

Lift the film holder until the roller and the hook and loop fastener hit each other lightly and fix the holder with screws (2).

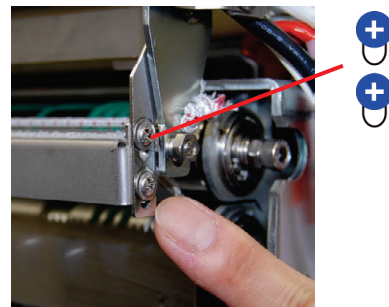
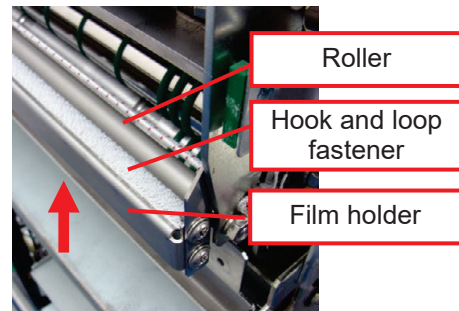

2. Similarly, adjust the film holder at the other side and fix it.

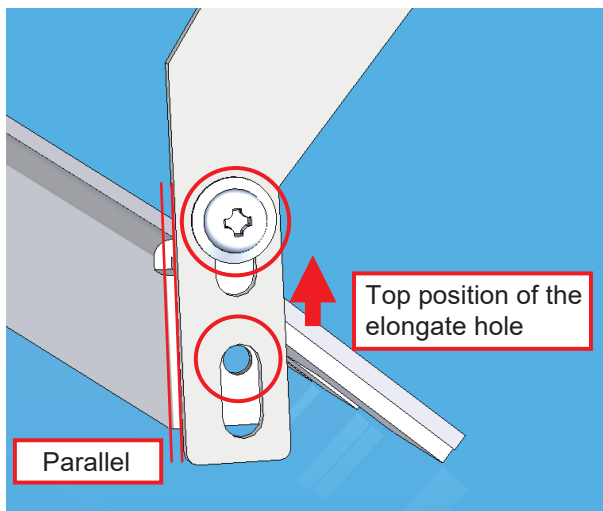

NOTE: Film arm must be parallel to the bracket

2. Adjust the position of the leaf spring and then adjust the pinching force between the HOLDER and ROLLER.

The force should be 3.5 to 5.5N when an A4 size copy paper is pinched with the short side parallel to the holder and pulled out.

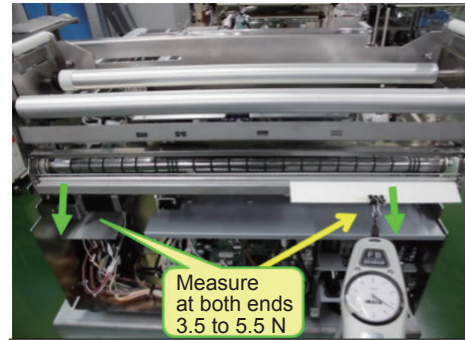
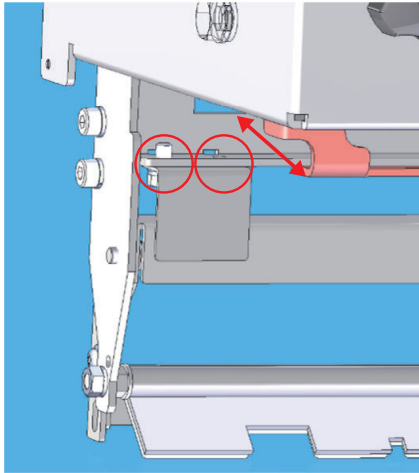

3. Check that adjustment is complete.

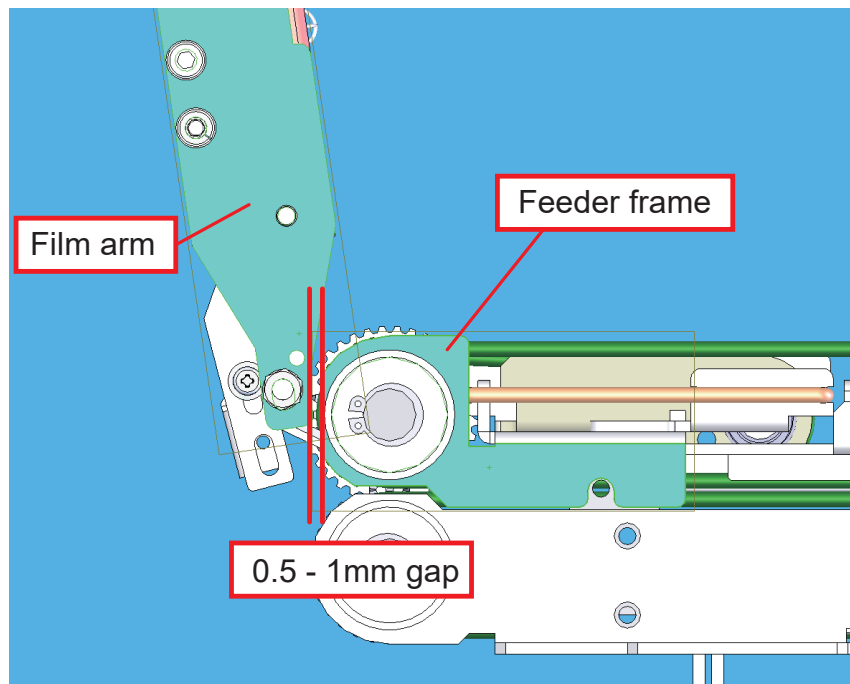

- Adjustment is OK if film arm is parallel to the bracket.

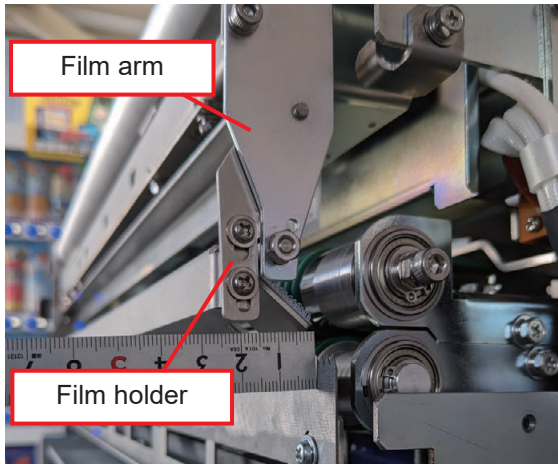

- Adjustment is OK if a gap is created between the film holder and the film arm with the film arm in the pressed condition (conveying position). If no gap is found, re-adjust the film holder position.

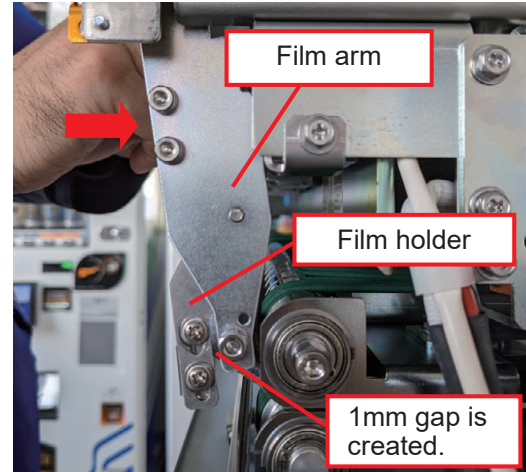

- Adjustment is OK if the roller rotates smoothly with the film arm pushed into the deepest point (until it hits the stopper).

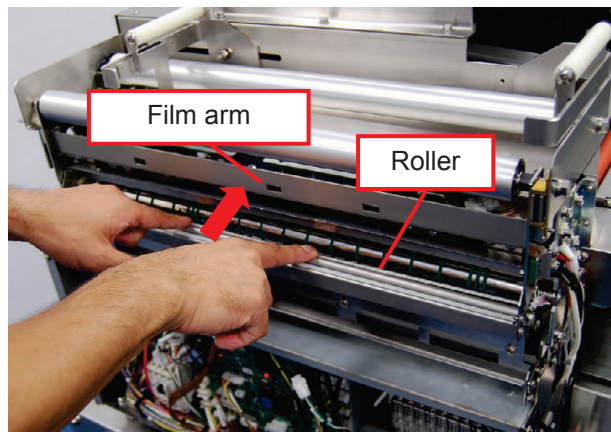

[5] Adjusting outside stopper position

1. Lift the cutter and adjust the outside stopper's position so that the gap between the tip of the film arm and the cutter is 4 mm, and then, fix the stopper.
2. In a similar way, adjust the stopper in the back to have the gap of 4 mm.

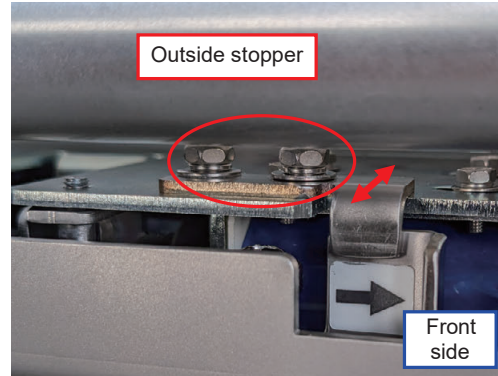
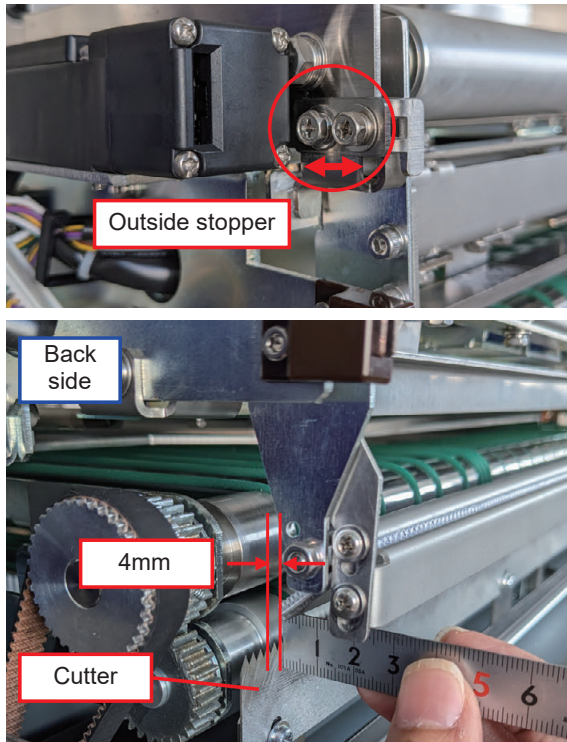

NOTE: In mounting the left lateral cover, pay attention for the cover not to hit the film holder.

[6] Adjusting solenoid

1. Adjust each solenoid's position as follows.

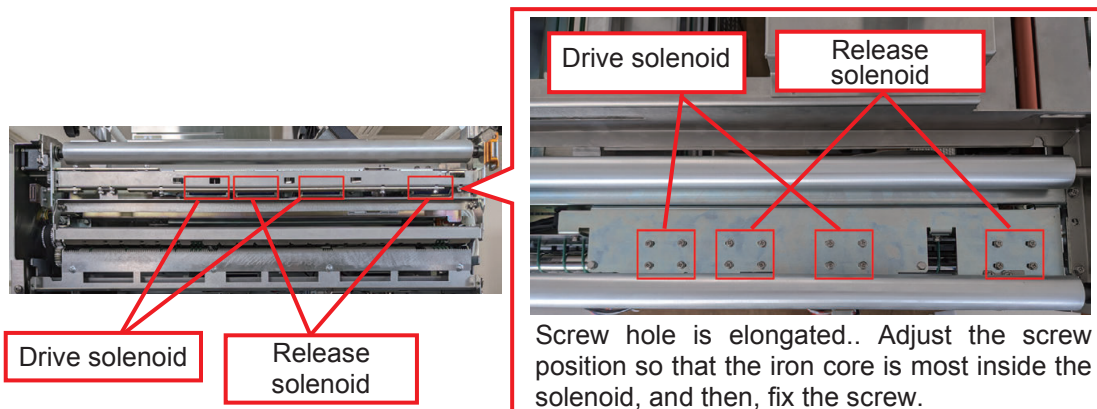

Drive solenoid: It shifts the film arm toward inside (film conveying position).

Release solenoid: It shifts back the film arm toward outside (origin point).

NOTE: If the release solenoid is not adjusted properly, the following trouble may occur:

- Film cutting operation is abnormal when film-over error is released.
- Film cutting operation is abnormal after film is conveyed.

2. Check that solenoid's position is properly adjusted.

- Adjustment is OK if a gap is created between the film holder and the film arm while the film arm is being pushed (conveying position).

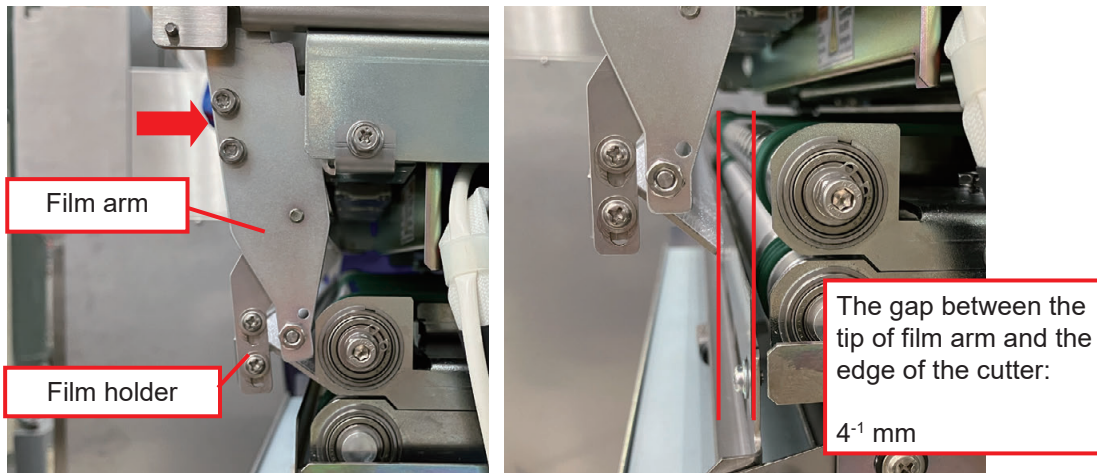

- If the front edge of the cut film does not stick out of the front end of the film holder, check the release solenoid's position.

NOTE: You can check the results of solenoid adjustment through actual operation by executing [Unit Operation] - [Film Arm] in the Maintenance Adjustment Mode.

[7] Adjusting the detection plate of the film conveyance origin point sensor (cutter safety sensor).

Before this adjustment, carry out "(4) Adjusting outside stopper position" to adjust the gap between the tip of the film arm and the cutter blade to 4 – 5 mm.

1. Touch the [UNIT ACTION] in the Adjustment Mode.

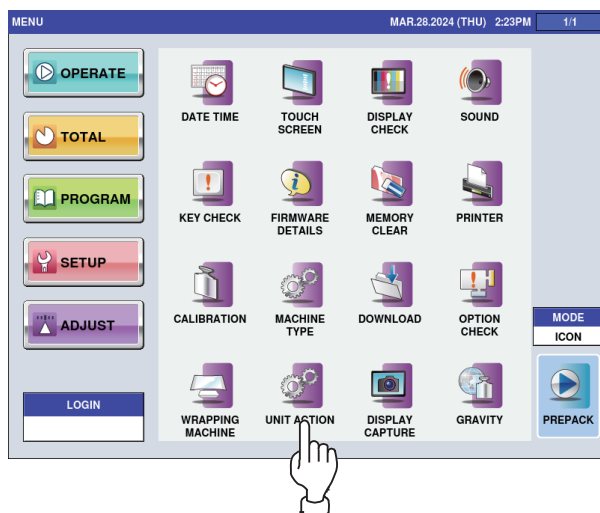

2. Select [ALL SENSOR CHECK] and touch [RUN]

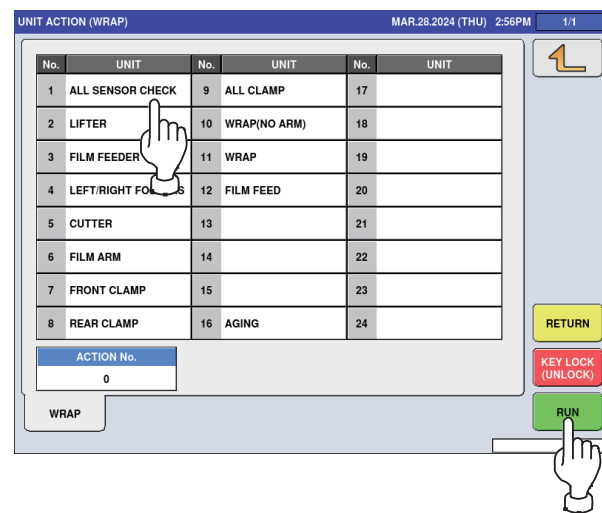

- Lift and hold the cutter blade at the same height as that of the front end of the film holder, and push the film arm in small steps inward from the standby position (position with the film holder lowered).

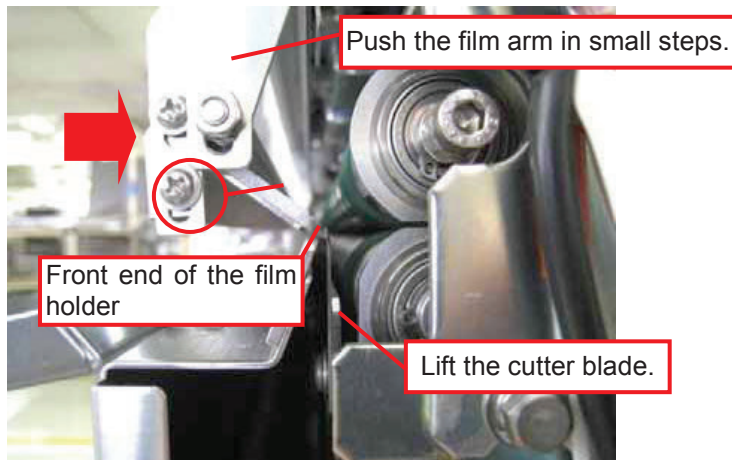

- Check the position where the sensor reacts sounding “pip-pip.” If the reaction occurs at around the middle point between the arm standby position and the cutter blade, adjustment is OK. This completes detection plate adjustment.

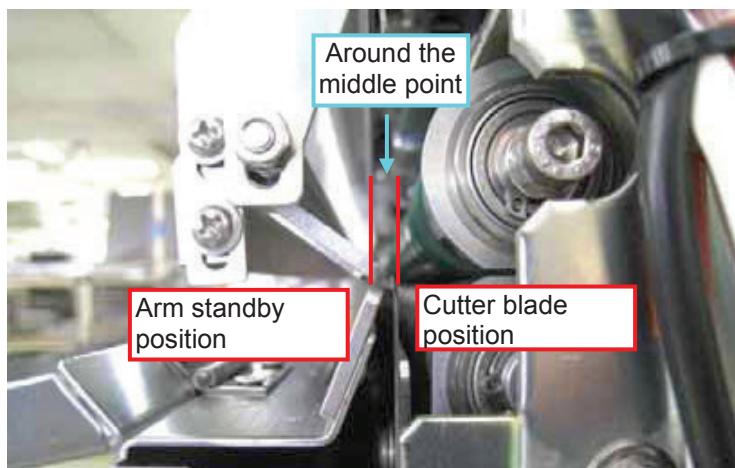

- If reaction does not occur at around the middle point, adjust the position of the detector plate. The screws (2) fixing the detection plate have elongated holes. Adjust the position of the elongated holes so that the sensor reacts at around the middle point.

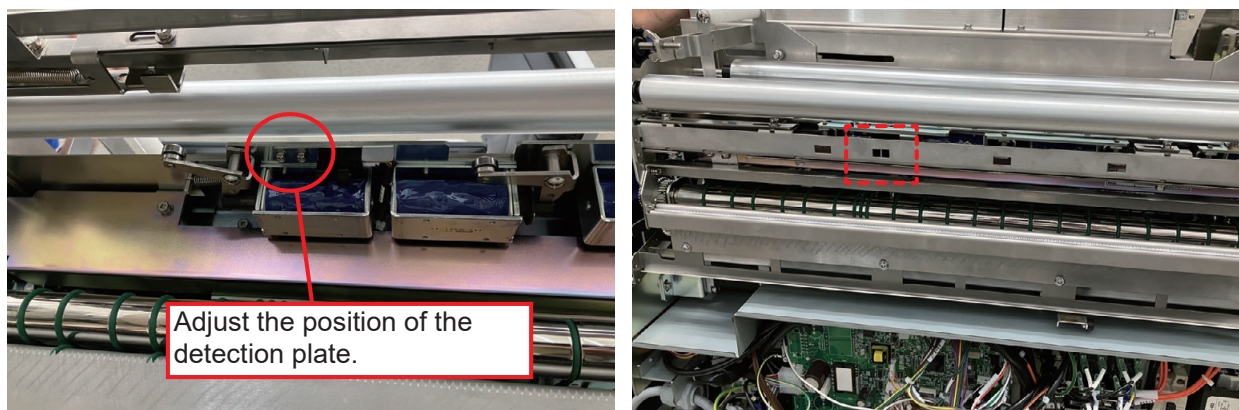

- Repeat the procedure 3 – 5 until the sensor reacts at around the middle point.

5.2.3 Adjusting the Operating Range of the Infeed Unit's Claw

Adjust the claw operating range so that the gap between the infeed bar and the weighing plate is 5 mm when the infeed bar is at the farthest position in the back (farther back than the standby position)..

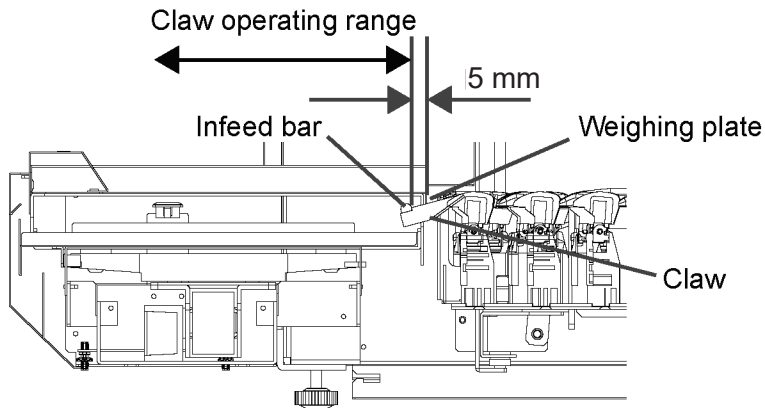

1. Touch the [UNIT TEST] in the Adjustment Mode.
2. Select [LIFTER] and touch [RUN]

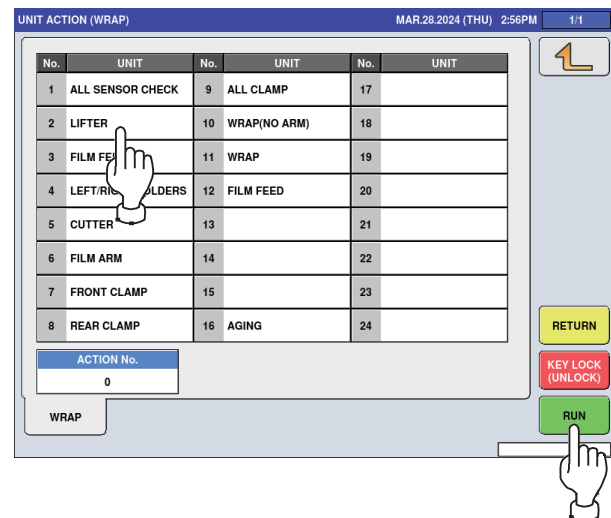
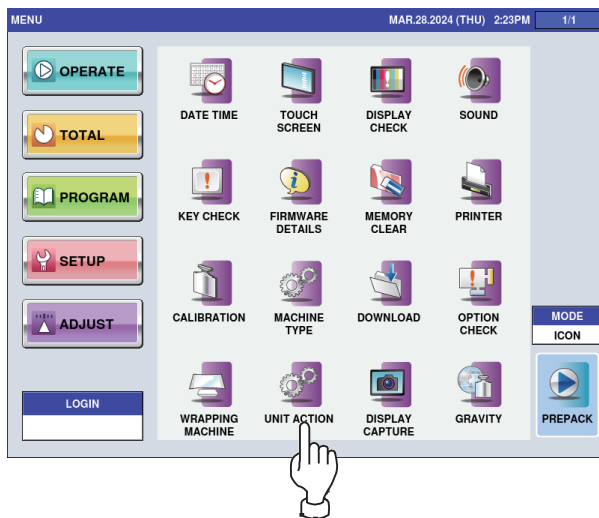

3. Check that the gap between the infeed bar and the weighing plate is 5 mm when the infeed bar moves to the farthest back.

NOTE: <When the tray's infeed position on the lift needs to be farther back>

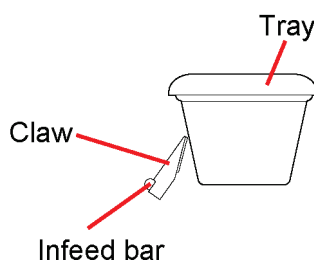

If the tray's position is too high or the tray's brim cannot be successfully pushed as shown in the figure on the left, reduce the dimension of the portion indicated by * in the figure above to move the infeed position on the lift toward farther back.

In changing the dimension of the portion indicated by mark *, check the following items.

- The tray having the maximum depth dimension used by the customer shall not hit the cover inside the wrapping machine body.
- The infeed bar shall not hit the weighing plate holder.

- If the dimension is not 5 mm, stop unit's operation and adjust the operation range of the infeed unit's claw.

Carry out two types of adjustment for the claw operation range as described below..

- Adjustment of the position where the claw stops (no change in stroke width)
- Adjustment of claw's stroke width

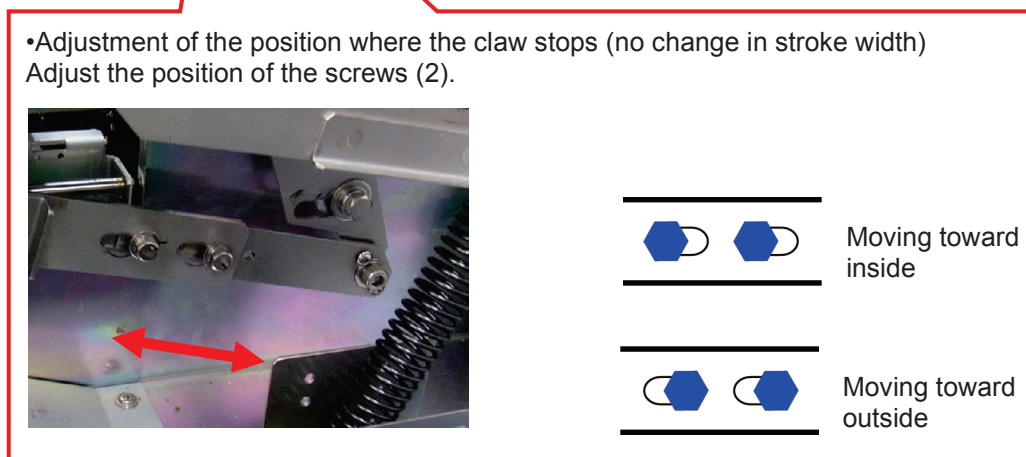
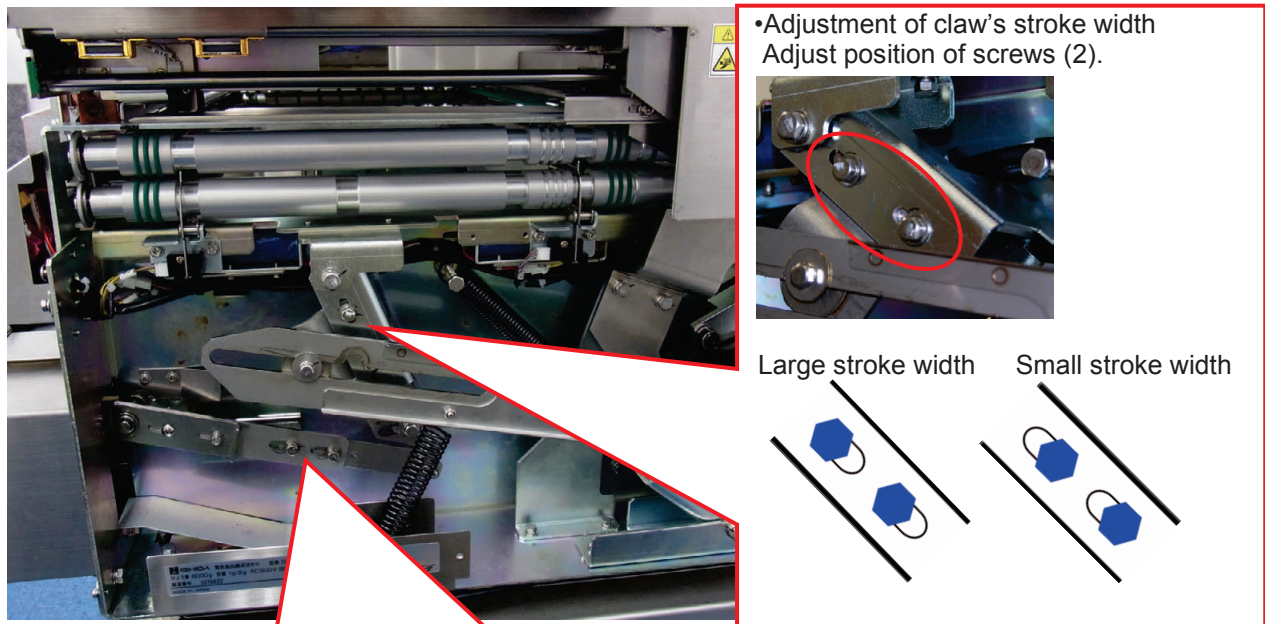

- Conduct adjustment until the gap between the infeed bar and the weighing plate is 5 mm.

5.2.4 Adjusting Cutter Solenoid Position

Fix the cutter solenoid with screws (2) at the position where the iron core is the most inside of the solenoid.

1. Turn the machine power switch OFF.
2. Loosen the screws (2) that fix the cutter solenoid.

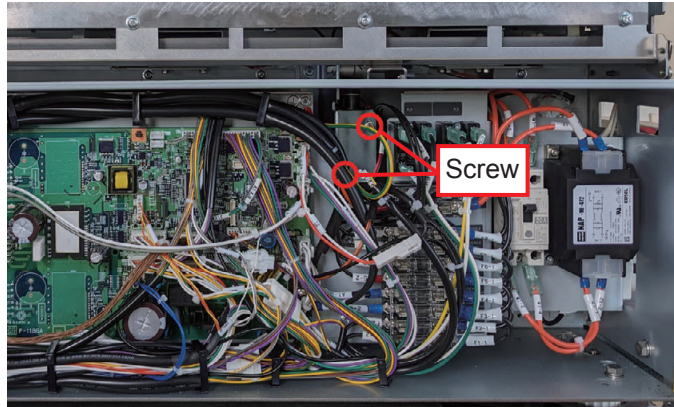

3. Screw holes are elongated allowing vertical position adjustment. Fix the solenoid with screws (2) at the position where the iron core is the most inside of the solenoid.

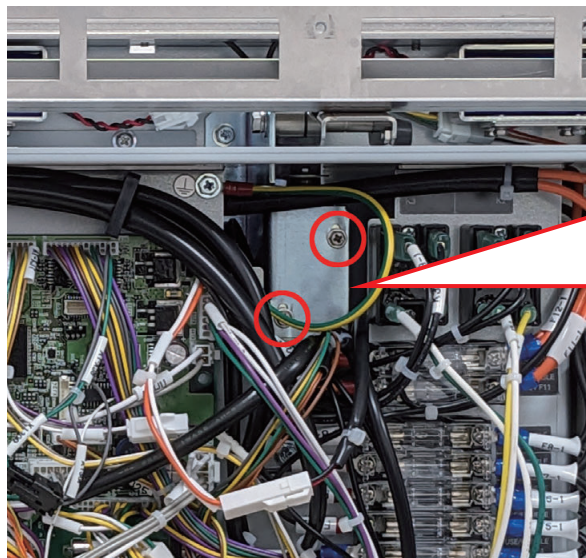

Set the solenoid at the position where the iron core is the most inside of the solenoid.

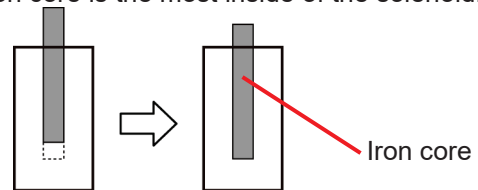

Fix with screws (2).

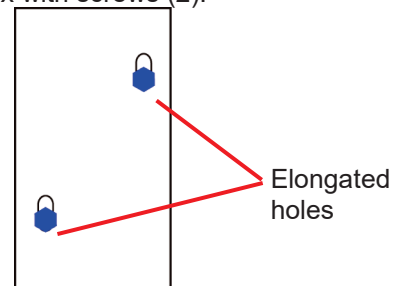

Adjust the position of the solenoid that the E-ring and rubber washer of the solenoid contact the body when the gap between the front side stopper screw and the main frame is 0.5 mm. Never adjust at back side.

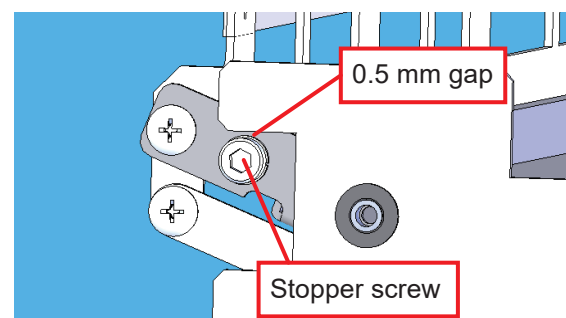

5.2.5 Adjusting Cutter Blade Position

Adjust the cutter blade position when cutter blades are replaced or the unit is disassembled.

Screw holes are elongated allowing vertical adjustment. Fix the cutter blade position with screws (4).

Adjust the cutter blade position in a manner described below.

- If the cutter bracket has a mark-off line, adjust the cutter blade to the mark-off line.
- If the cutter bracket has no mark-off line, set the gap between bottom end of the cutter blade and the cutter bracket to 5 – 6 mm.

* Mount the cutter blade horizontally.

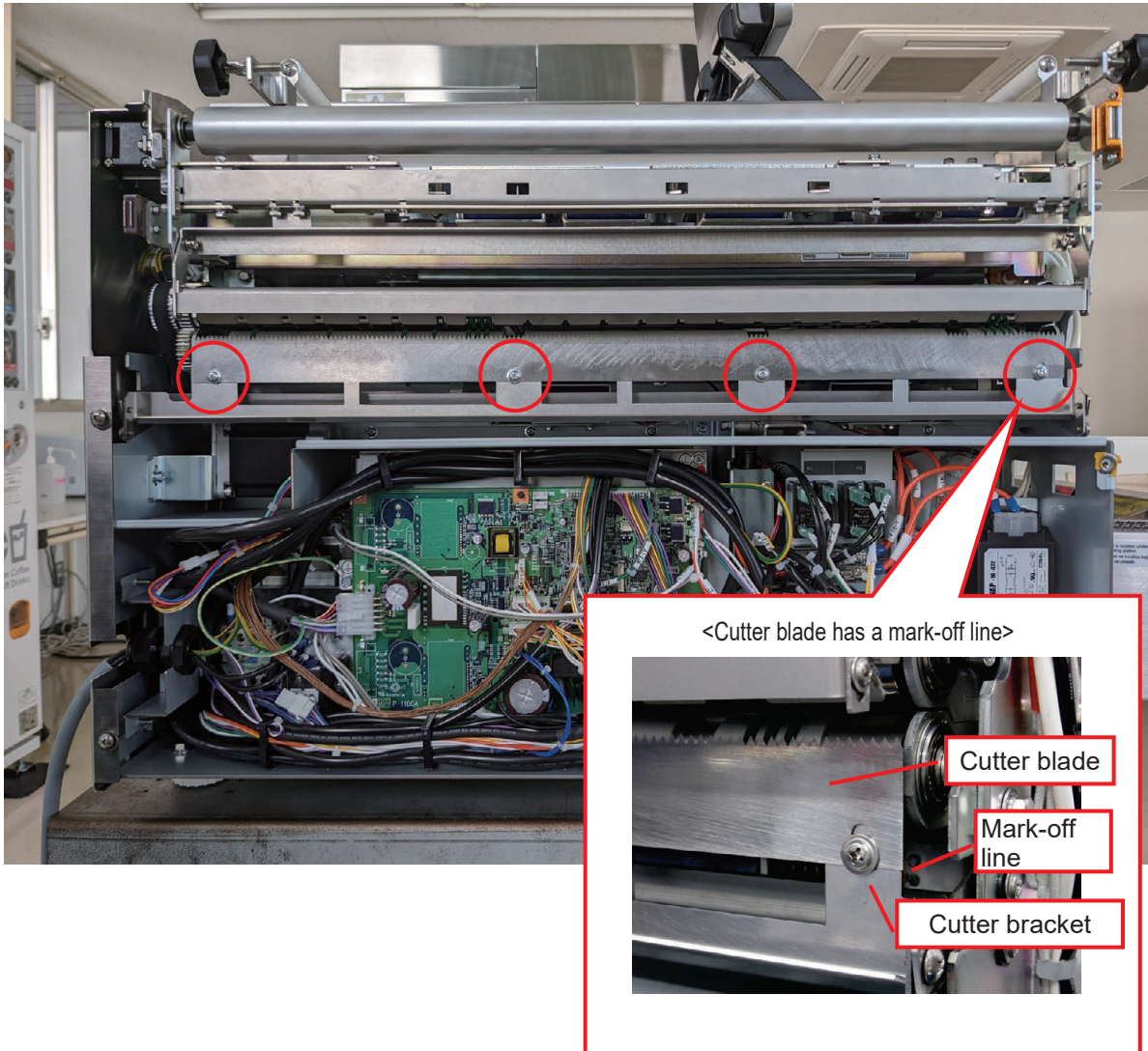

5.2.6 Adjusting Left and Right Squeezing Plates Widening Amount

Adjust the widening amount between the left and right squeezing plates to 366 – 369 mm.

1. Touch the [UNIT ACTION] in the Adjustment Mode.
2. Select [LEFT/RIGHT FOLDERS] and touch [RUN]

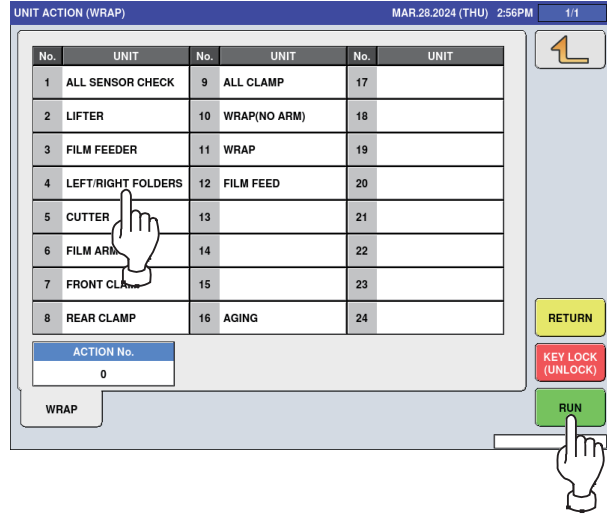
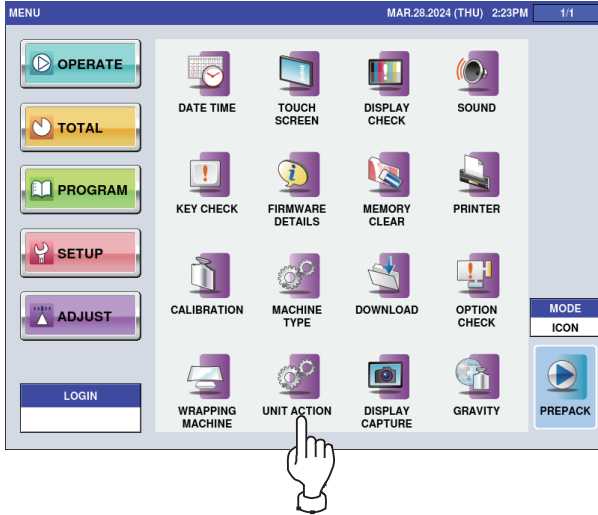

3. When the left and right squeezing plates reach the both ends, check that their widening amount is 386 – 369 mm.

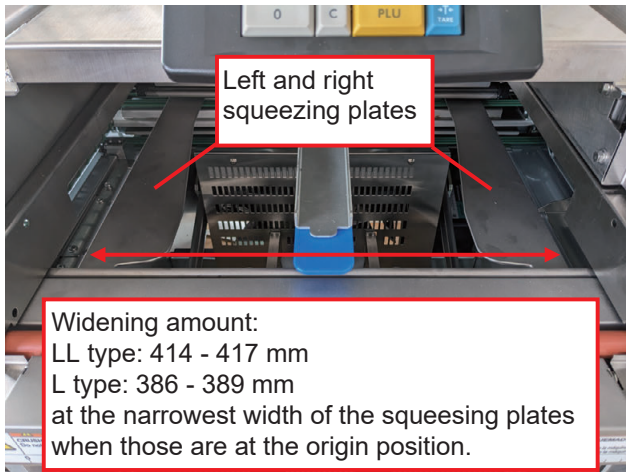

LL type	414 - 417 mm
L type	386 - 389 mm

4. If the widening amount is not 366 – 369, adjust the amount with screws (2) on the detection plate attached on the left squeezing plate.

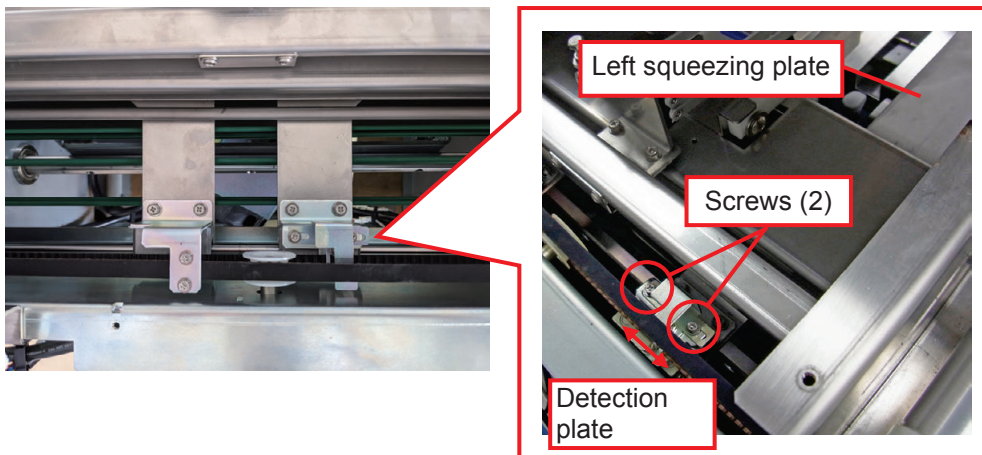

5.2.7 Adjusting Squeeze Amount of the Rearqueezing Plate

Adjust the squeeze amount of the rearsqueezing plate in such a way that the gap created by the rearsqueezing plate when the rearsqueezing plate moves toward the nearest position is within $5\text{ mm} \pm 1\text{ mm}$.

1. Touch the [UNIT TEST] in the Adjustment Mode.
2. Select [LIFTER] and touch [EXECUTE.]

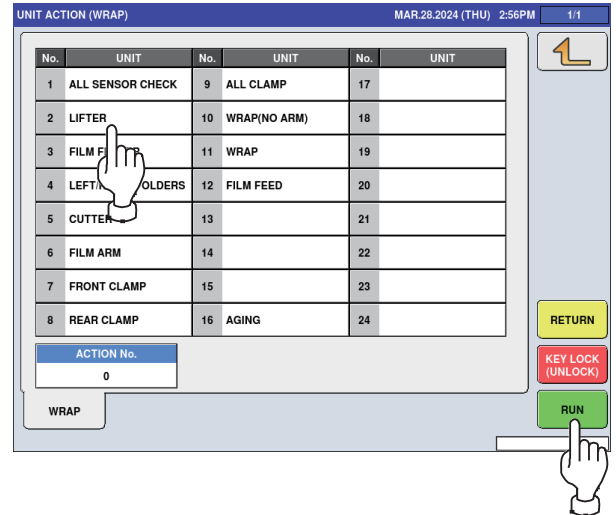
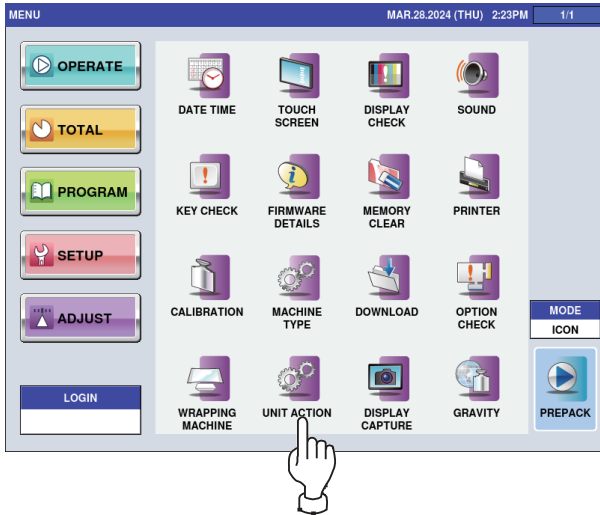

3. Check that the gap is within $5\text{ mm} \pm 1\text{ mm}$ when the rearsqueezing plate moves toward the nearest position.

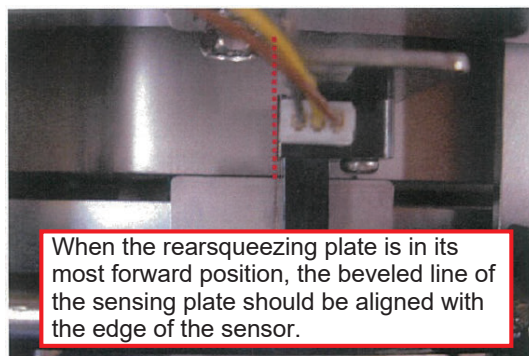
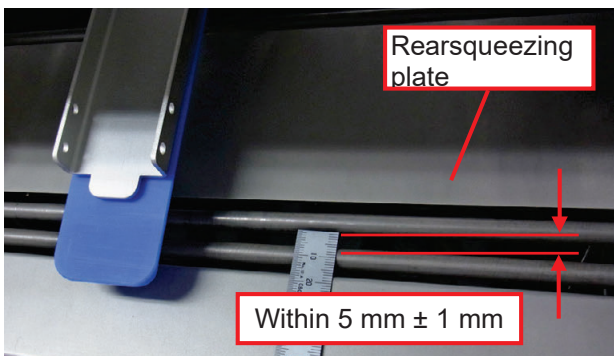

4. If the gap is not within $5\text{ mm} \pm 1\text{ mm}$, adjust the gap with the screws (2) of the rearsqueezing arm on the right lateral.
5. Move the rearsqueezing plate back and forth once and check that the rearsqueezing arm does not hit the detection plate and the sensor.

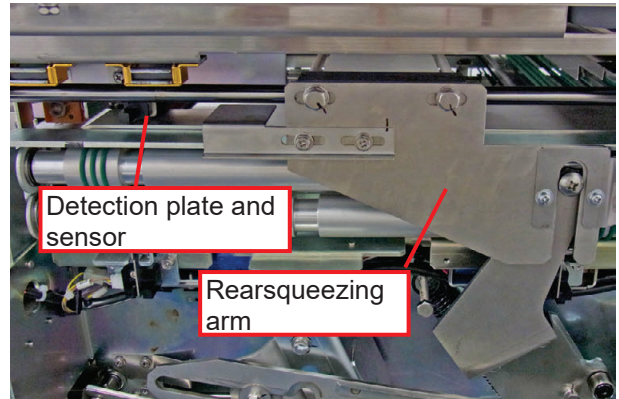
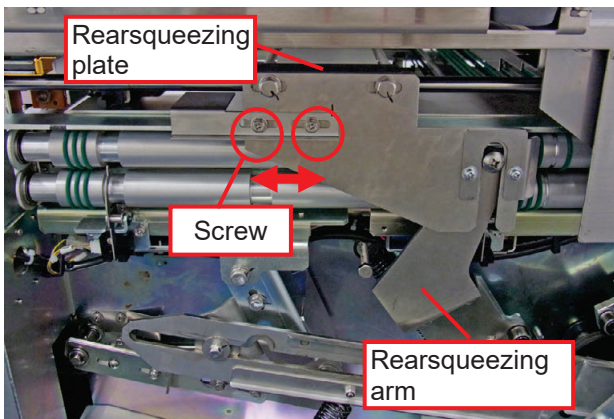

5.2.8 Adjusting Discharge Pusher Standby Position

Adjust the standby position of the discharge pusher as follows:

1. Check that the standby position of the discharge pusher (from the front of the discharge pusher to the backside of the plate).

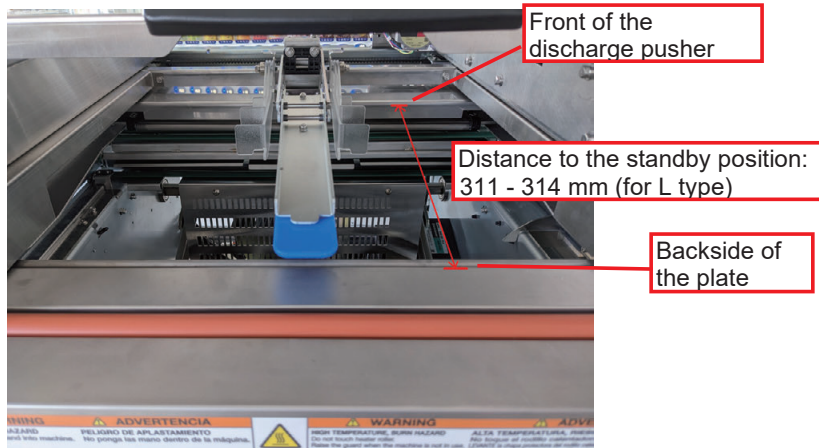

2. If the standby position is incorrect, adjust the position with screws (2) on the discharge pusher arm at the right lateral.

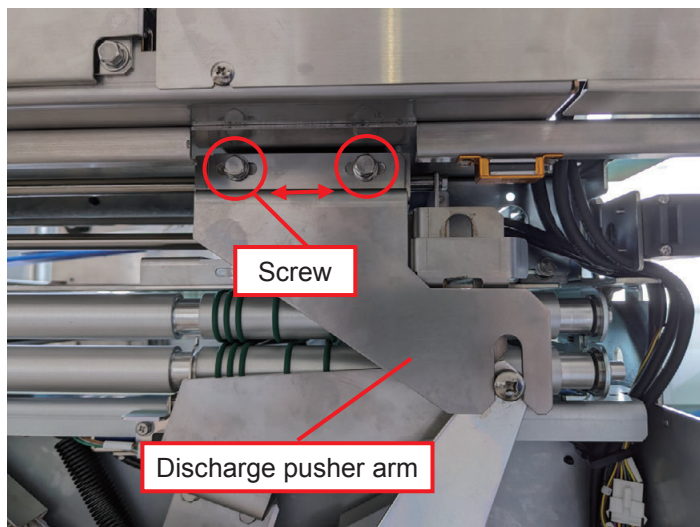

3. After adjustment, activate the discharge pusher and check again the distance to the standby position.

5.2.9 Adjusting Tray Holder Height

Adjust the height of the tray holder as follows: Adjust the space between the front end of the tray holder and the plate to 20 ± 1 mm with a hexagonal bolt.



5.2.10 Adjusting Claw Height of the Infeed Unit

Adjust the claw height of the infeed unit as follows:

1. Loosen the screws (4) on the right lateral of the infeed unit.



2. Adjust the space between the top surface of the infeed unit and the infeed bar to 6 - 7 mm.
Measure the height at the back of the front claw on the right lateral of the infeed unit as shown in the photograph below.

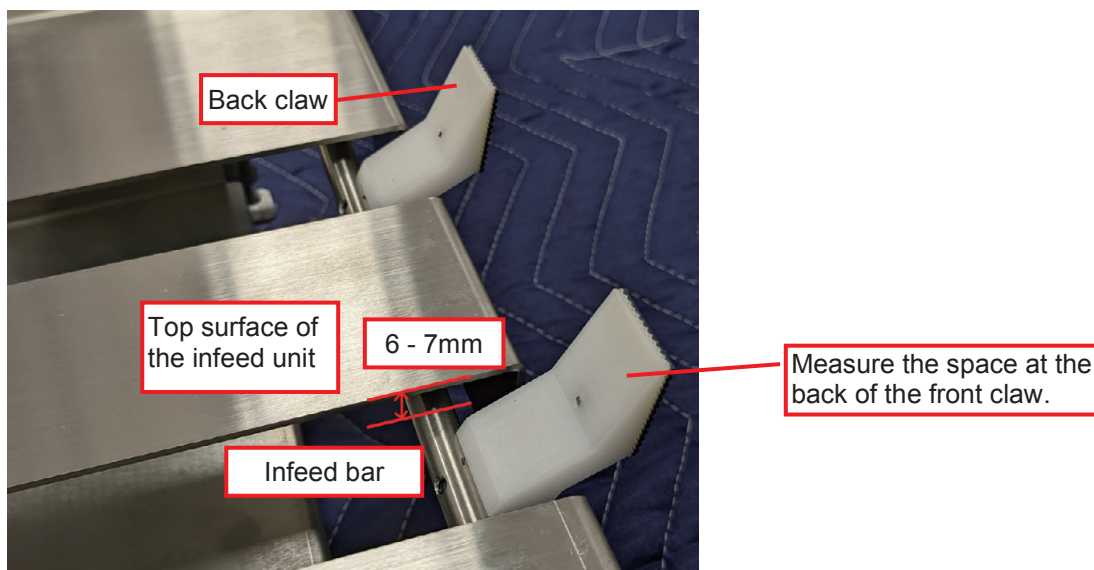

5.3 Parts Replacement

5.3.1 Print Roller (Linerless)

Replace the roller every time when the label sheet of the linerless printer passes 20km.

1. Open the door on the right side of the printer and remove the label roll.

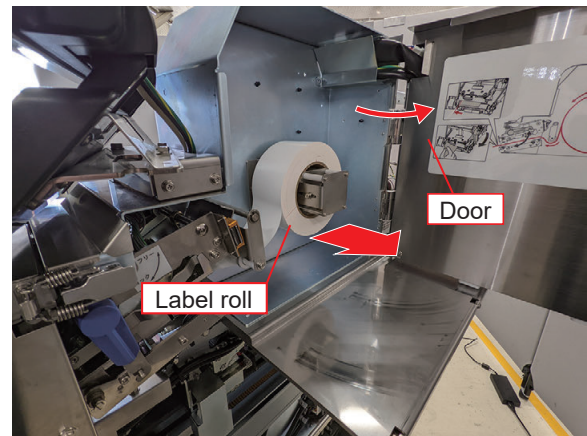

2. Release the lock and open the front door of the printer unit.

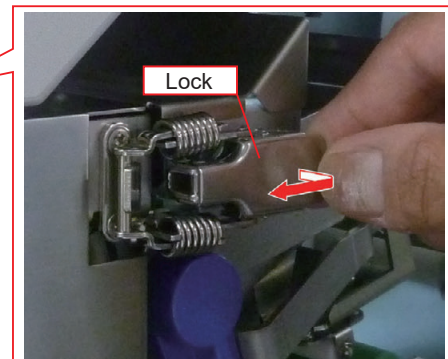
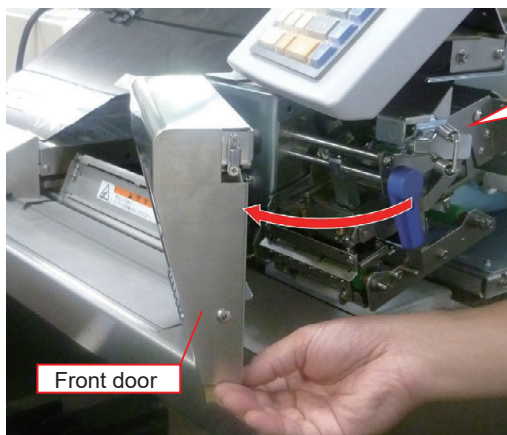

3. Push up the head release lever.

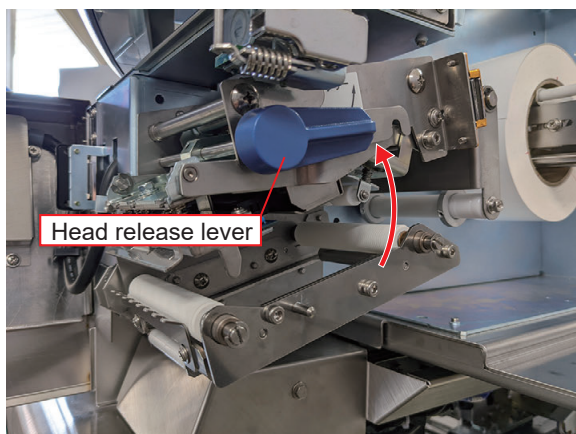

4. Use hexagonal wrench and remove the 3 screws. Then remove the roller holding plate.

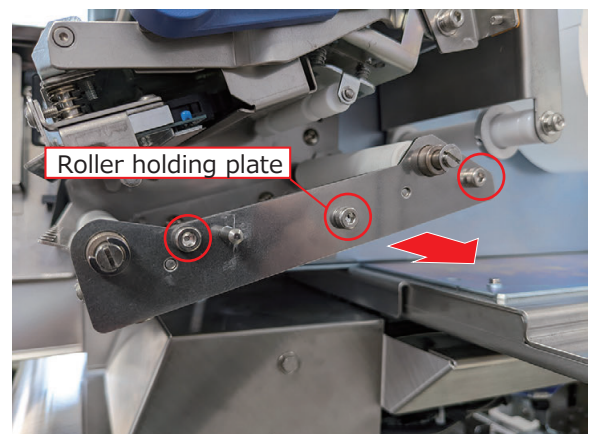

5. Take out the 2 printing rollers. Both rollers are the same part.

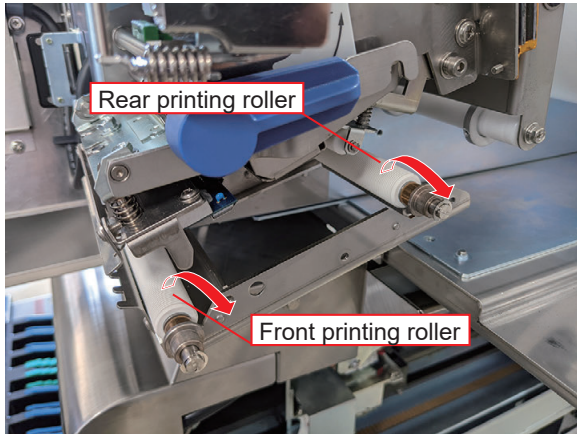

6. Remove the E-ring, flange, and spacer from the printing roller.

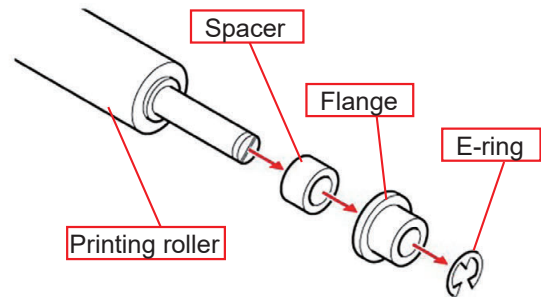

7. Replace the printing roller in this condition.

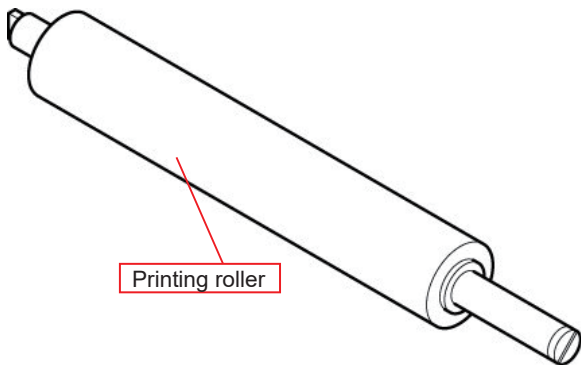

8. Install the spacer and flange on the printing roller and hold with the E-ring.

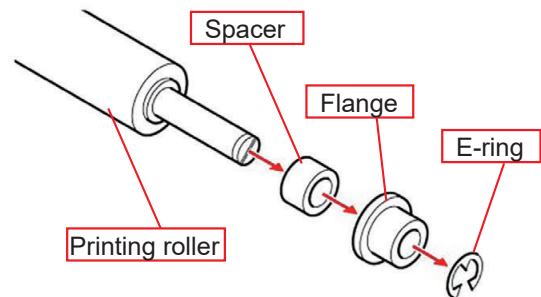

9. Install the 2 printing rollers.
Turn and push in the printing roller until the convex part of the printing roller snaps into the groove of the pulley.

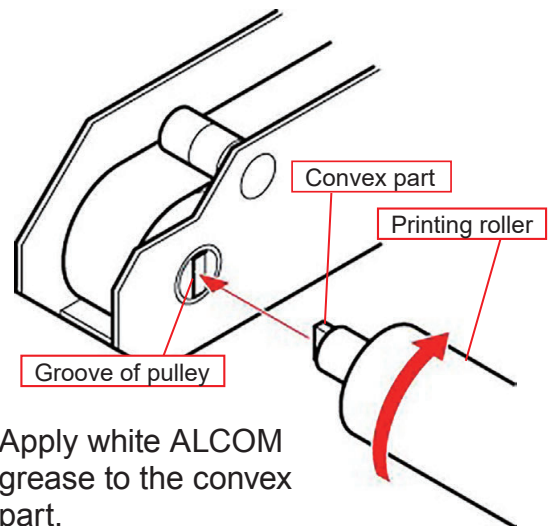
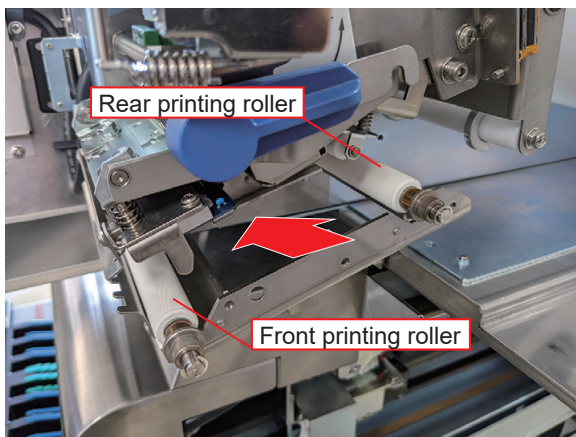

10. Install the roller holding plate to match the 2 dowels and tighten the 3 screws.

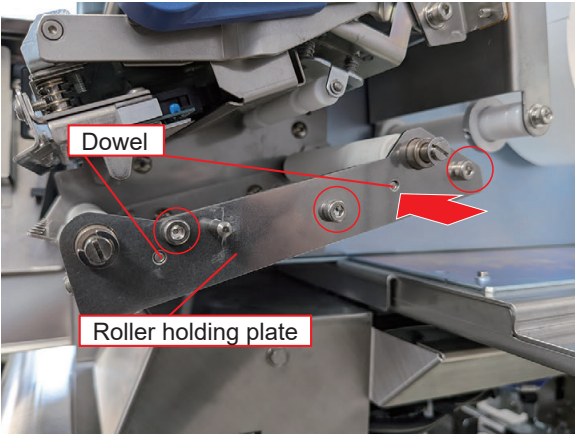

11. Return the head release lever to the original position and lock.

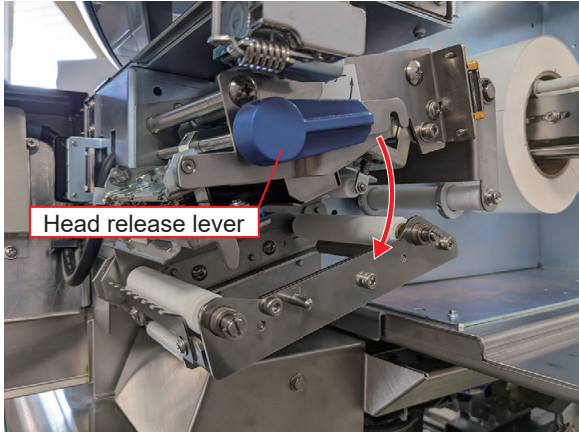

12. Close the front door and lock.

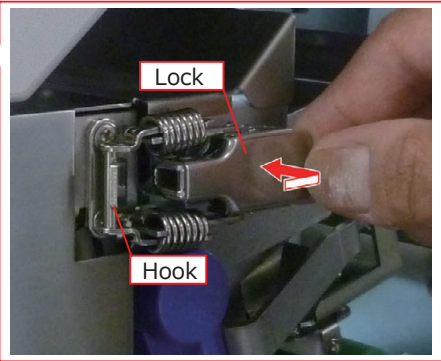
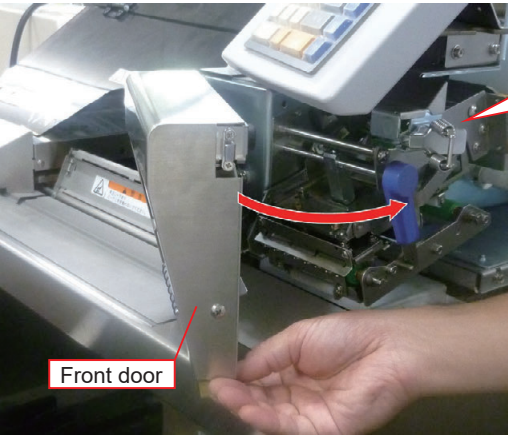

Hook the lock lever on the hook and push.

13. Place the label roll and close the door.

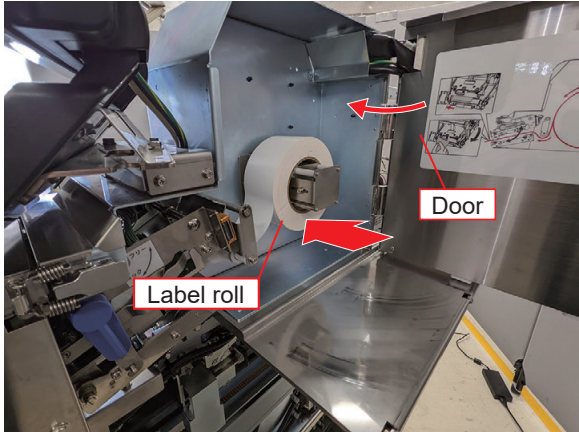

5.3.2 Print Roller (with liner)

Replace the roller every time when the label sheet passes 20km.

1. Open the front door of the printer unit.



2. Open the door on the right side of the printer and remove the label roll.



3. Push up the head release lever.

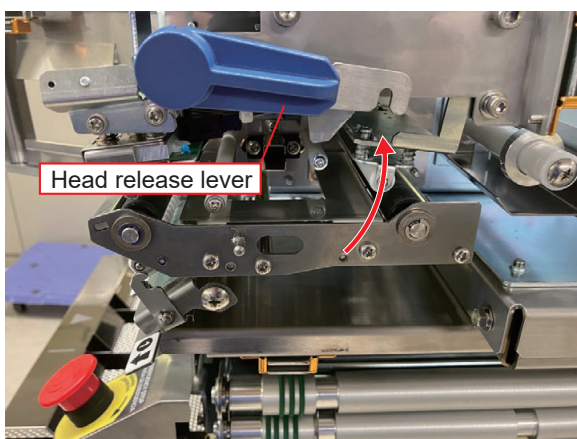

4. Remove 2 E-rings and 4 screws.

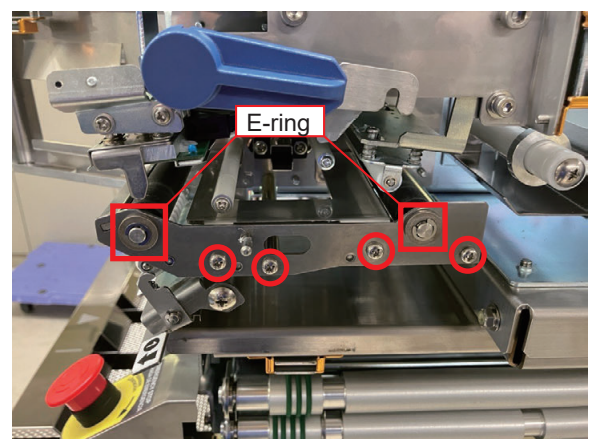

5. Remove the roller holding plate.
Be careful not to drop the peeling bar.



6. Use hexagonal wrench and loosen the 2 screws to loosen the belt tension.

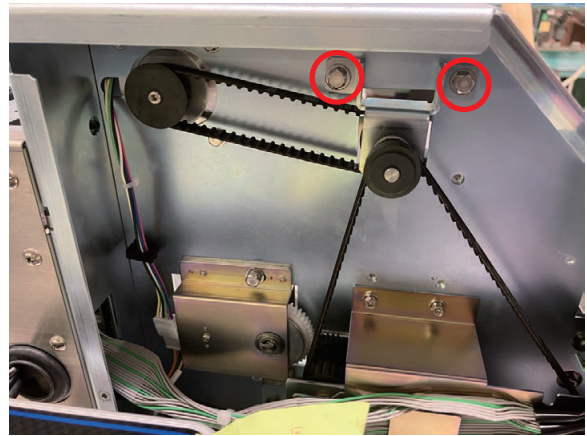

7. Remove the 2 timing pulleys.
It is more convenient to have a pulley remover.

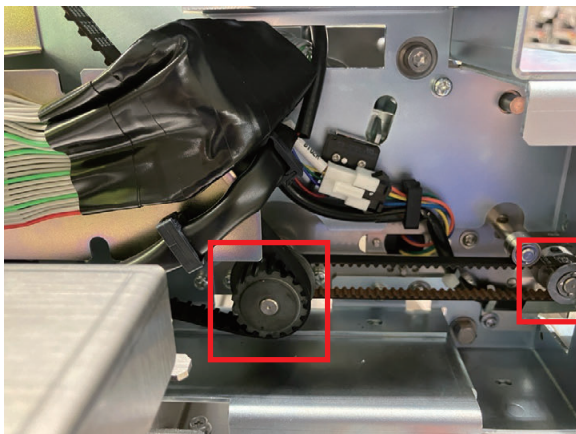

8. Remove the 2 printing rollers.
Assembly is in reverse order.



5.3.2 Timing Belt

2 timing belts are used in the printer unit. Replace both belts every XXX hours of use at the same time.

1. Open the door on the right side of the printer and remove the label roll.

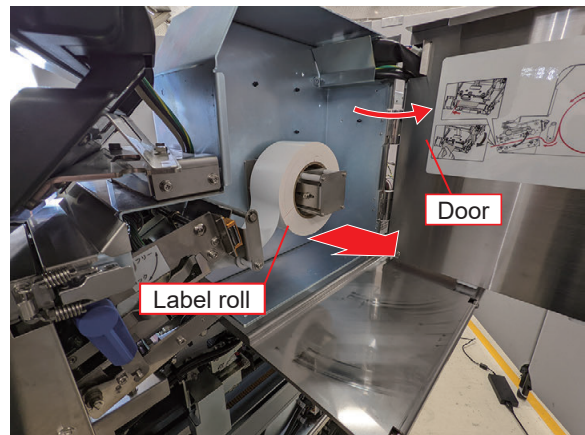

2. Release the lock and open the front door of the printer unit.

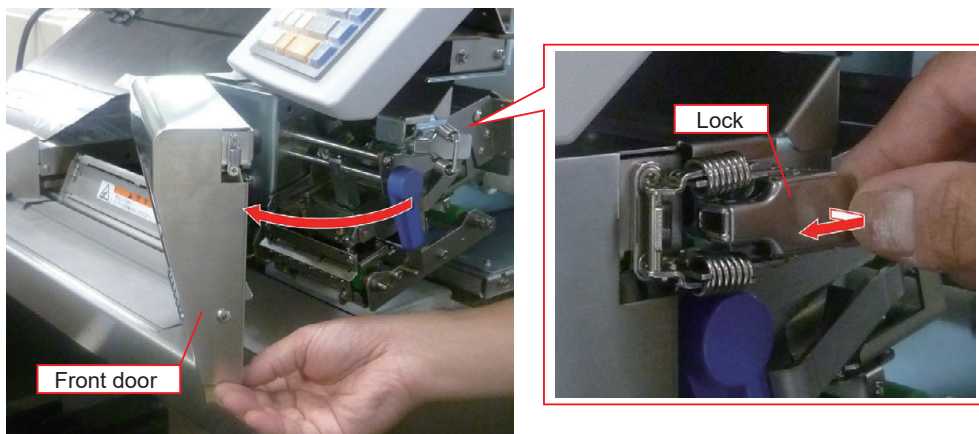

3. Push up the head release lever.

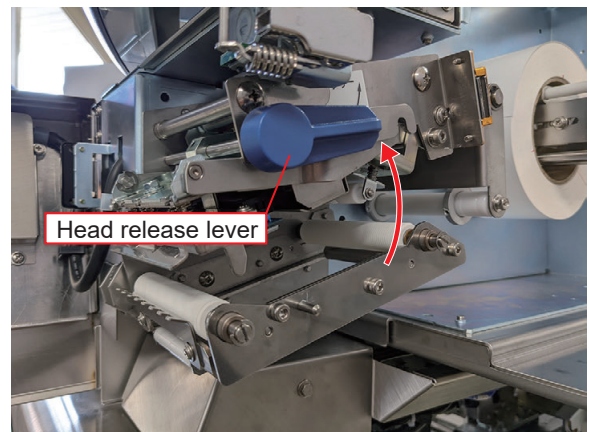

4. Remove 1 screw on the front side, 3 screws on the left side, and 3 screws on the top side then remove the printer cover in the direction of the arrow.

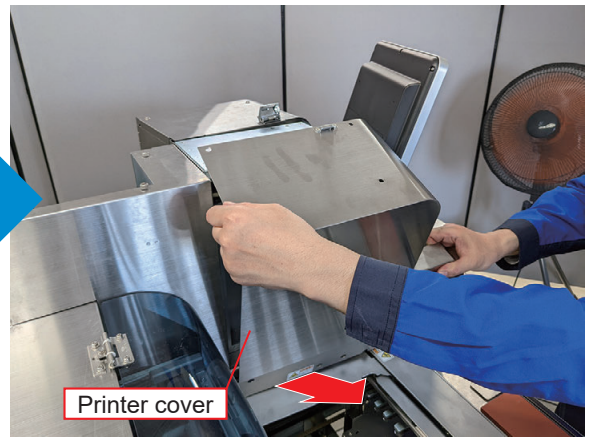
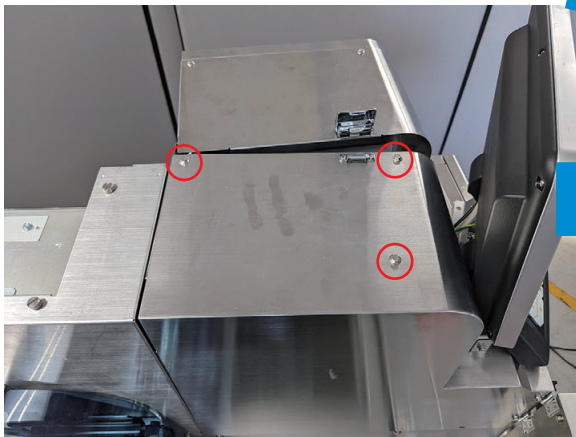
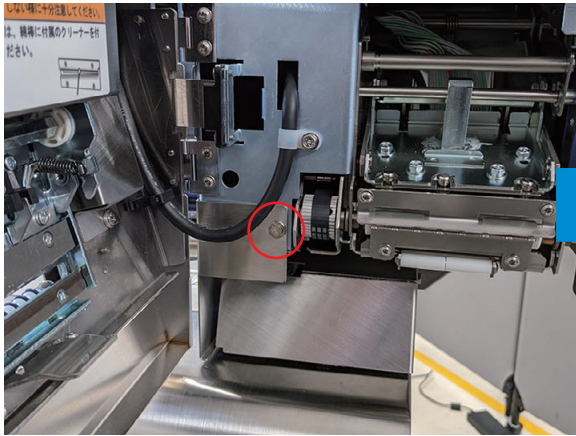

5. Loosen the 1 hexagonal bolt and lower the belt pulley that stretches the timing belt 1.

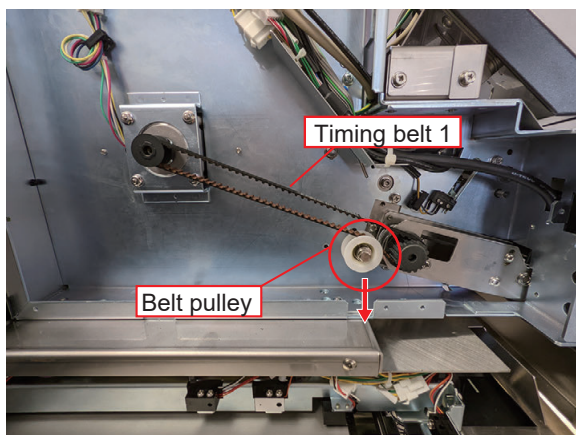

6. Remove the timing belt 1 from the lower side of the bracket first, then from the timing motor side.

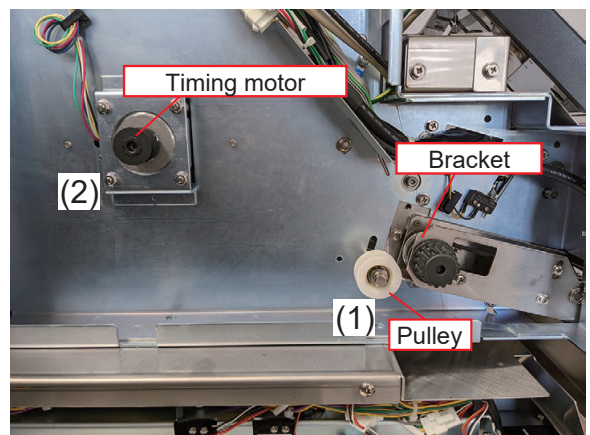

- Remove the 4 screws from the printing roller side. Screw A is roundhead and others are hexagonal.

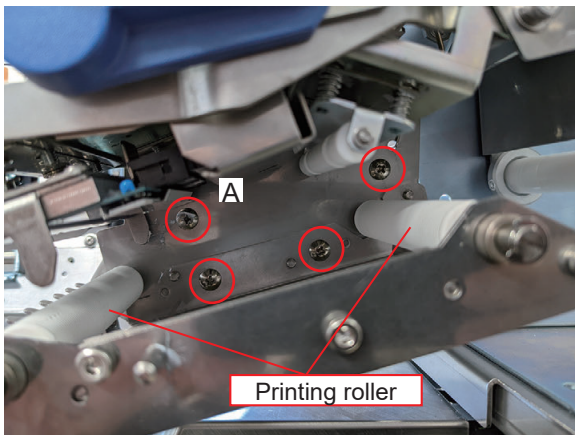

- Remove the pulley unit from the left side.

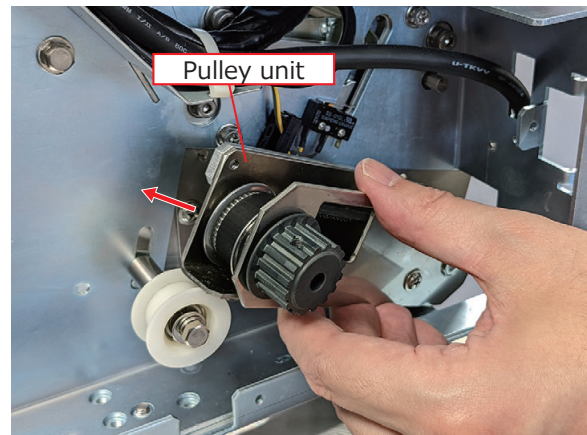

- Use hexagonal wrench and loosen the 2 screws, then remove the pulley and the washer.

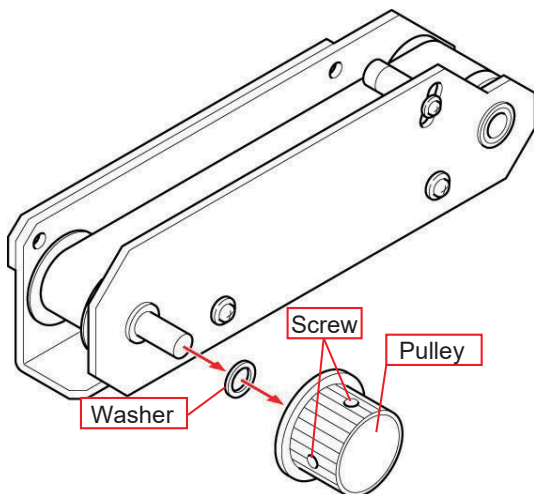

- Remove the 2 screws, remove the side plate, then remove the timing belt 2.

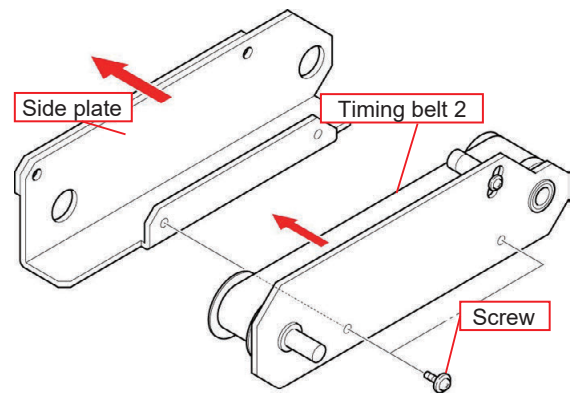

- Replace the timing belt 2, then install the side plate and tighten the 2 screws on the flat surface to make the bottom of the side plate and the bottom of the bracket on the belt side parallel.

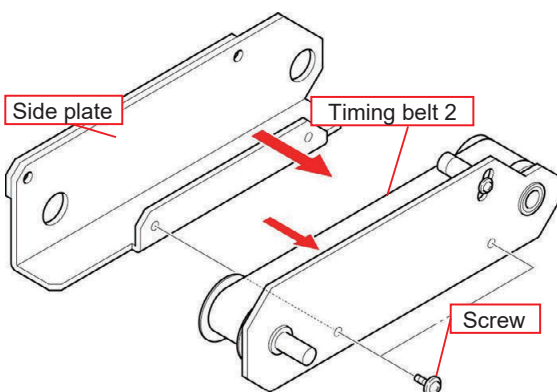

Frame and shaft must be perpendicular

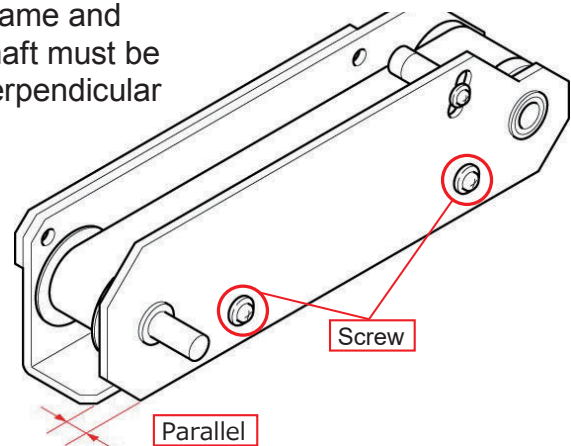

12. Install the washer and the pulley, then tighten the 2 screws with hexagonal wrench to secure the pulley.

Push the pulley until it butts up.

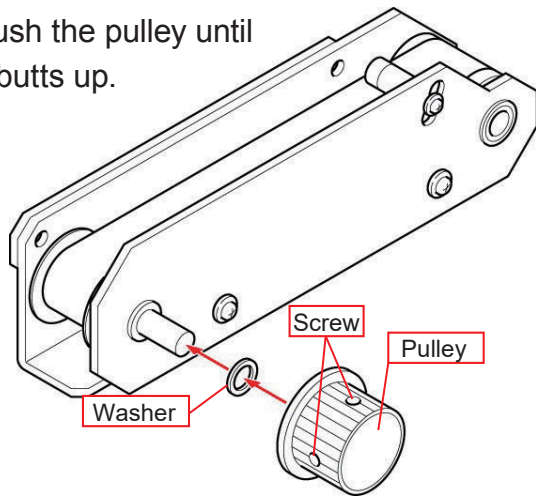

13. Insert the pulley unit from the left side.

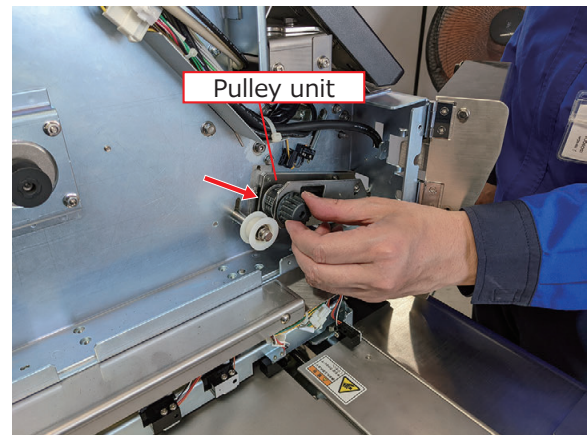

12. Install the 4 screws from the printing roller side. Screw A is roundhead and others are hexagonal.

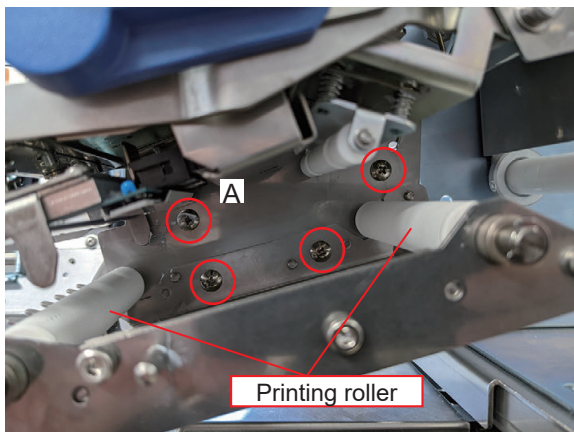

Since the timing belt and printing roller will be adjusted later, the screws should be temporarily tightened at this point.

The timing belt will not turn smoothly when the convex part of the printing roller does not mated with the groove of the pulley.

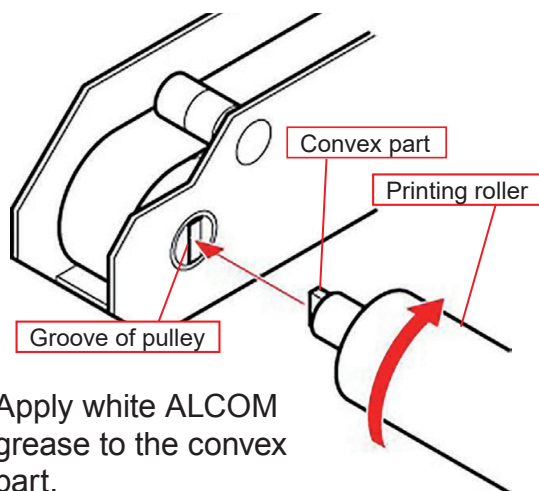

Apply white ALCOM grease to the convex part.

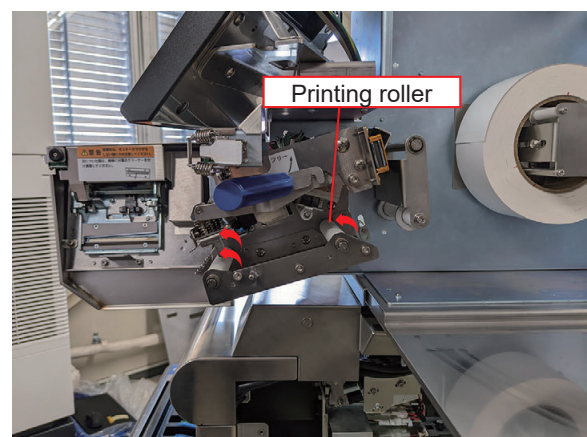

15. Insert the timing belt 1.
Hook the timing belt 1 to the timing motor side first, then push in from the lower side of the bracket.

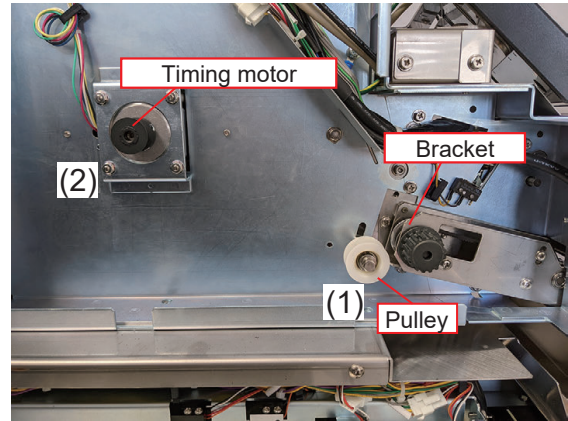

16. Push up the belt pulley and tighten the 1 hexagonal bolt.

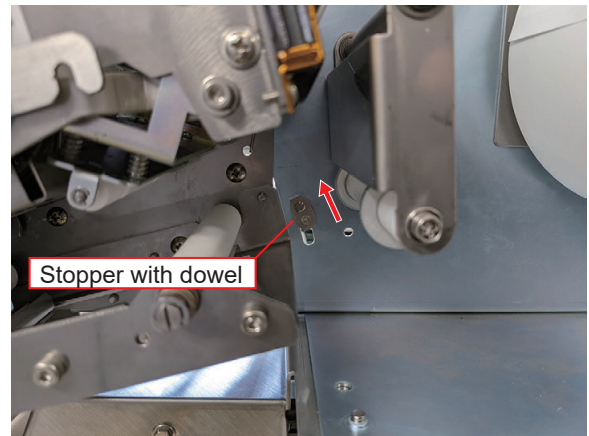
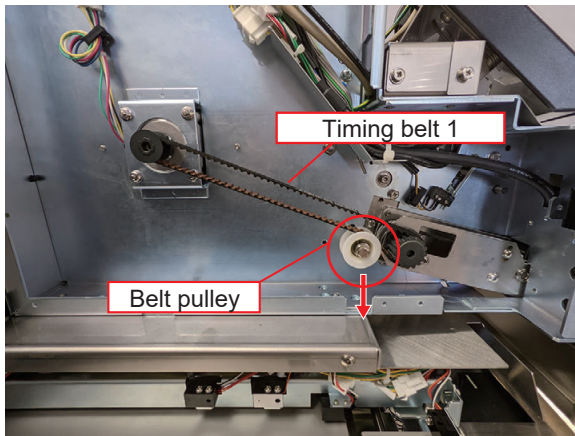

Lift up until the stopper with dowel on the back side is butts up.

17. Install the printer cover then tighten the 1 screw on the front side, 3 screws on the left side, and 3 screws on the top side.

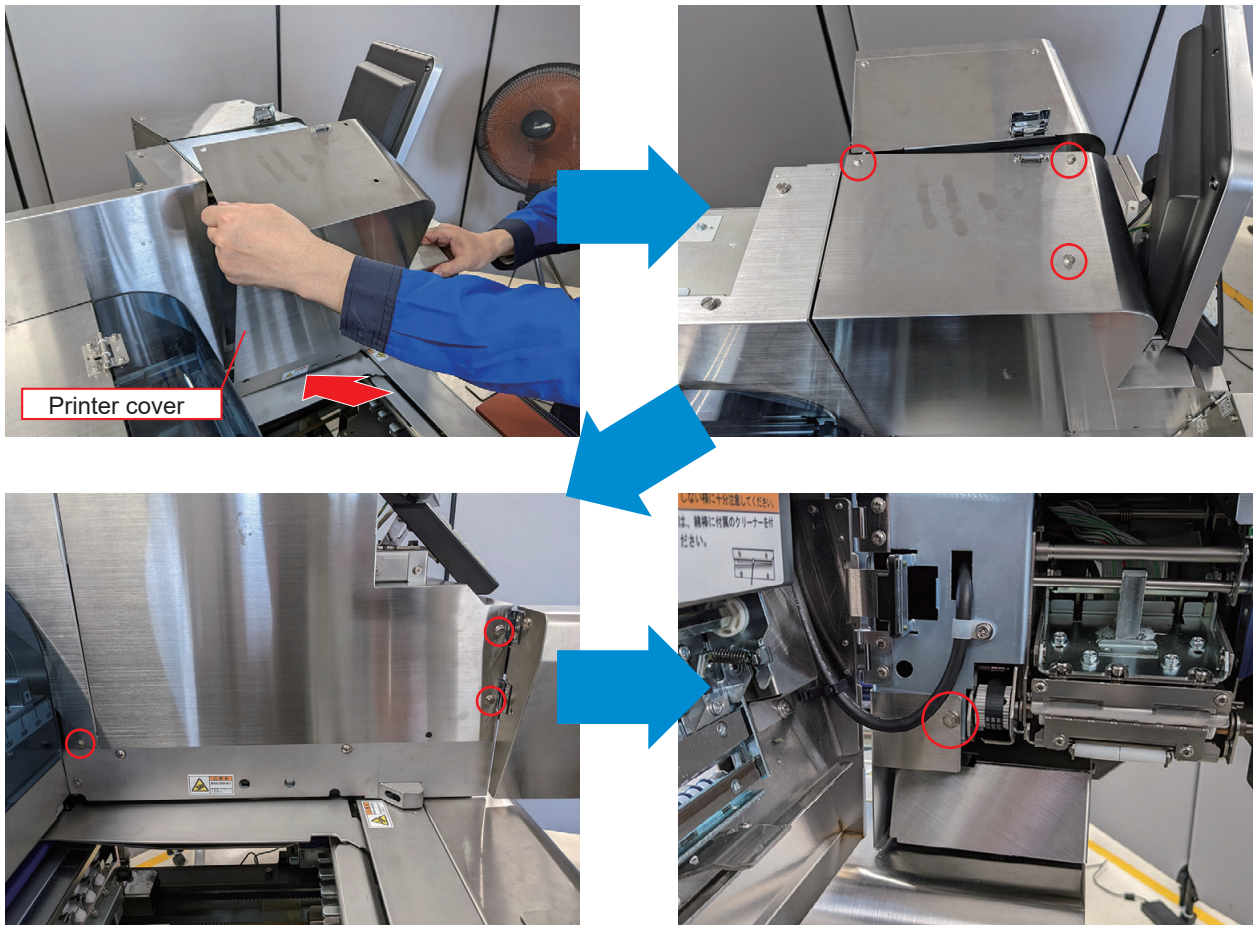

18. Return the head release lever to the original position and lock.

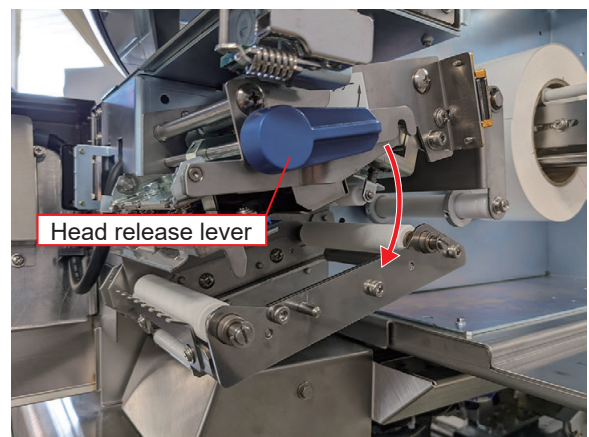

19. Close the front door and lock.

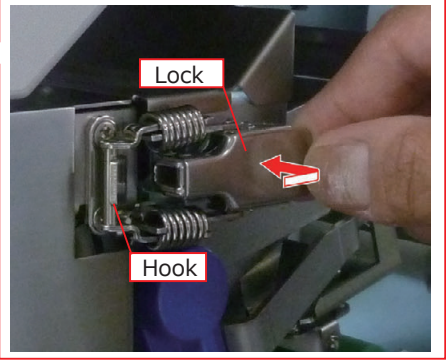
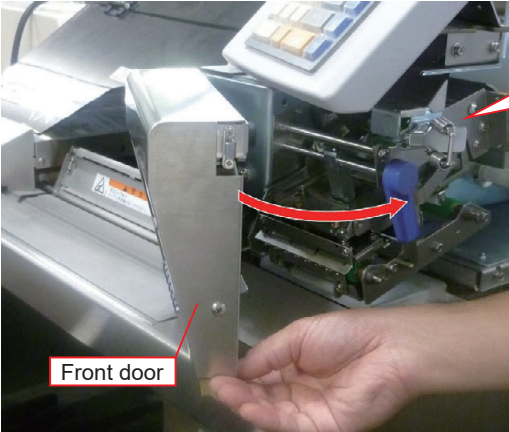

Hook the lock lever on the hook and push.

20. Place the label roll and close the door.

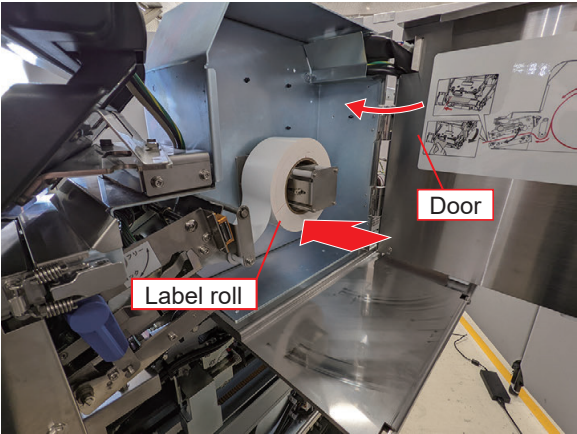

5.3.3 Cutter Unit

Replace the cutter unit every 500,000 uses.

1. Remove the 3 screws on the left and right side then remove the front cover.

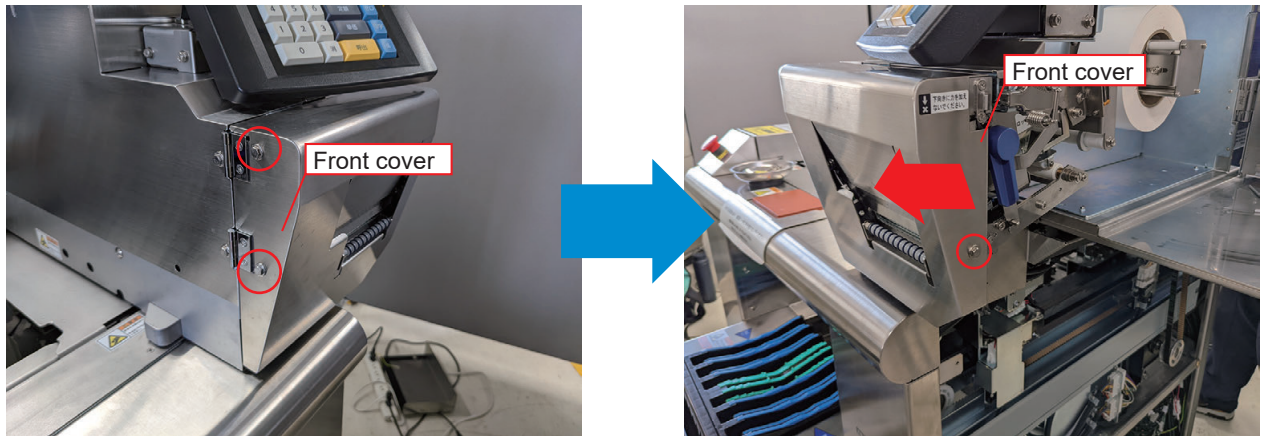

2. Release the lock and open the front door.

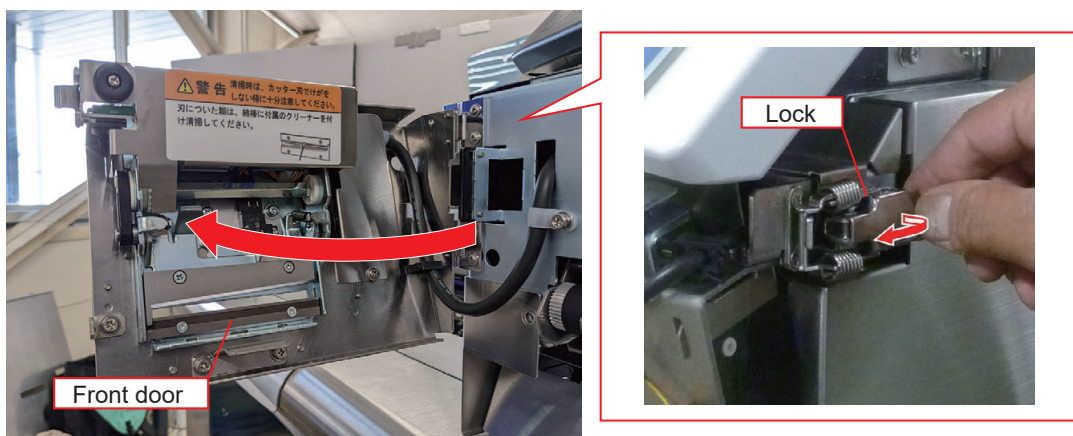

3. Remove the 1 screw and unhook the 3 hooks, then remove the cutter unit cover.

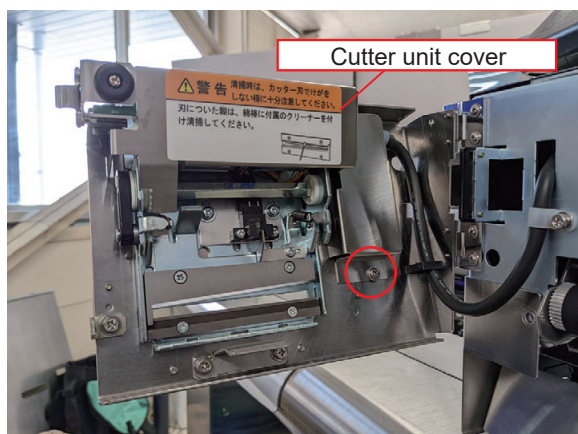

4. Remove the 1 screw that fixes the clamp and disconnect the 1 connector.

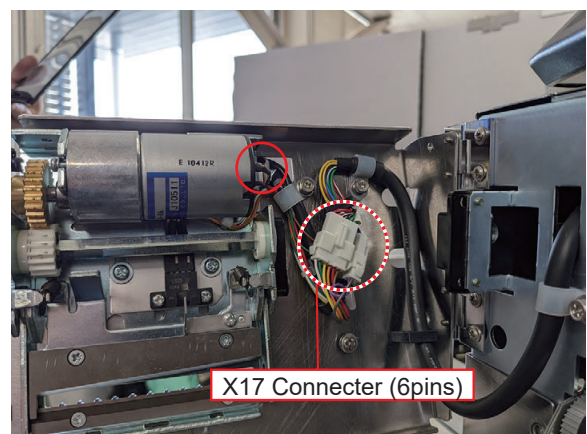

5. Mark the height of the cutter unit with a pen.

NOTE: The cutter unit requires adjustment. The cutter unit is adjusted to the height before replacement in this procedure, but refer to Cutter Unit Adjustment for details.

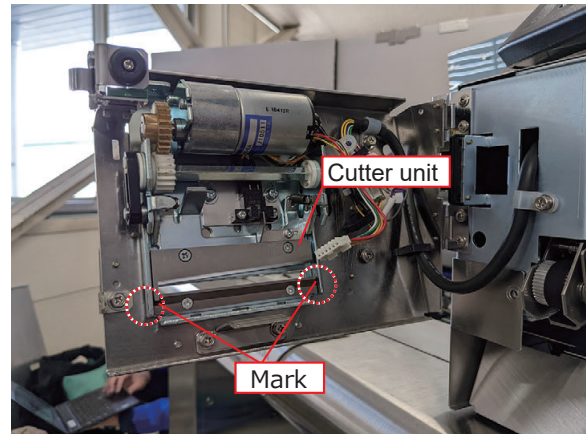

6. Close the front door and lock.

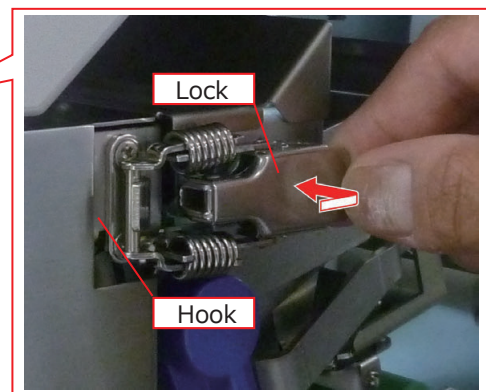

7. Remove the 2 screws.

NOTE: The screws are located under the cables, so remove the screws carefully to avoid damaging the cables.

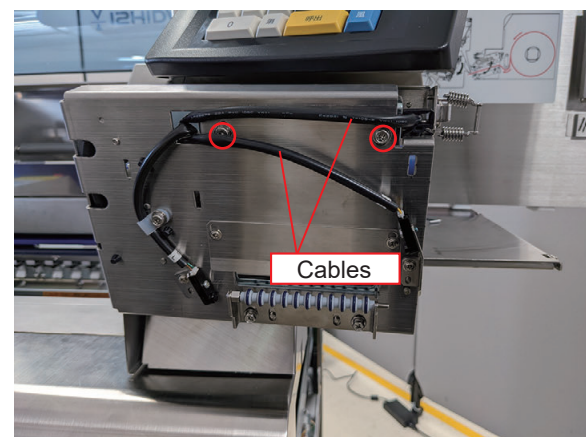

8. Release the lock and open the front door.

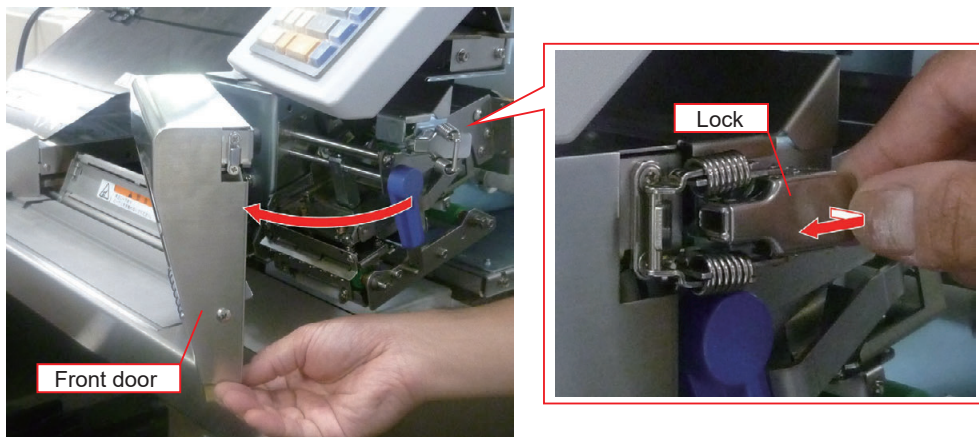

9. Remove the cutter unit.

**NOTE: Replace the entire unit.
Do not touch the cutter blade. It may cause injury.**

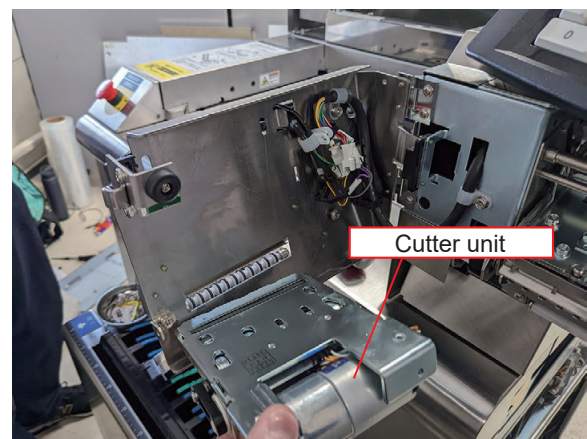

10. Install the cutter unit according to the marked height, then fix it by tightening the 2 screws on the front side.

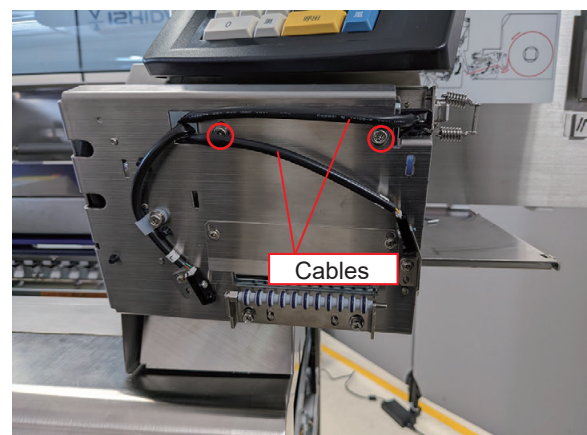
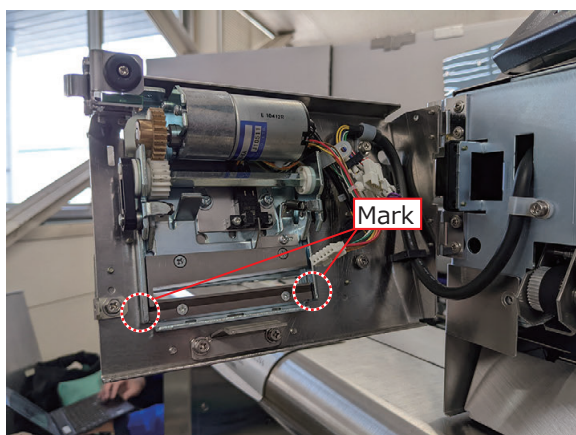

NOTE: The screws are located under the cables, so tighten the screws carefully to avoid engaging the cables.

11. Connect the 1 connector and tighten the 1 screw that fixes the clamp.

NOTE: Each connector has a different number of pins and only be connected with the pair. Do not force the connection.

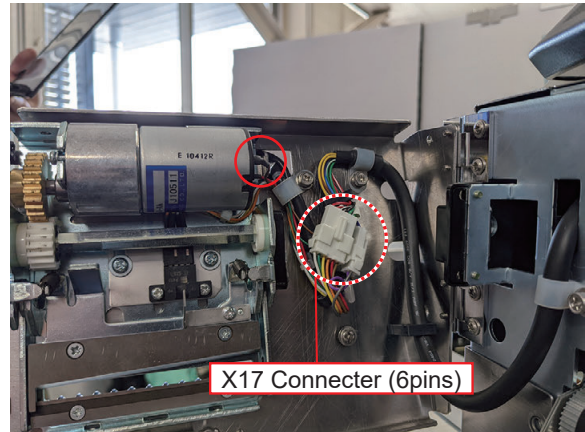

12. Install the cutter unit cover with the 3 hooks, then tighten the 1 screw.



13. Refer to the next 6.3.1 Cutter Unit Adjustment and adjust the cutter unit.

5.4 Adjustment

5.4.1 Cutter Unit

1. Open the door on the right side of the printer and remove the label roll.

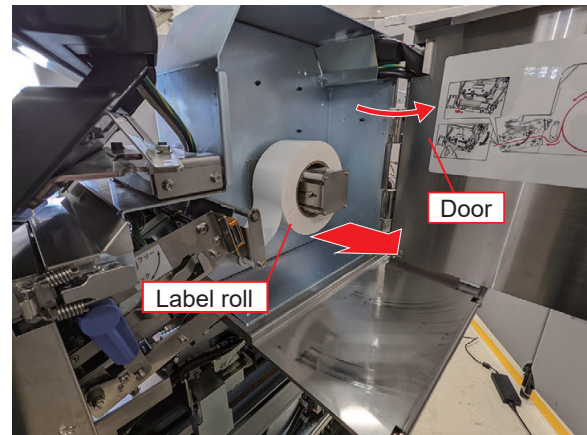

2. Remove the 3 screws on the left and right side then remove the front cover.

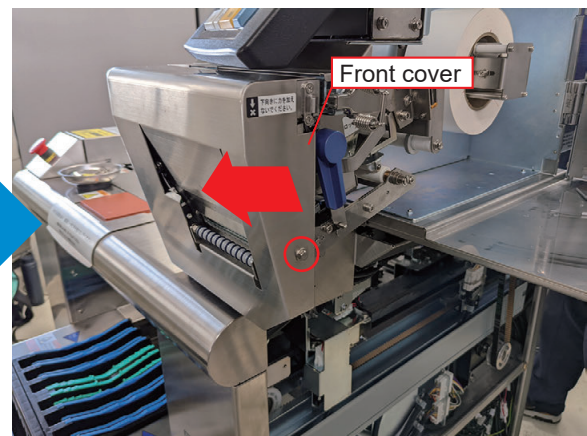

3. Release the lock and open the front door.

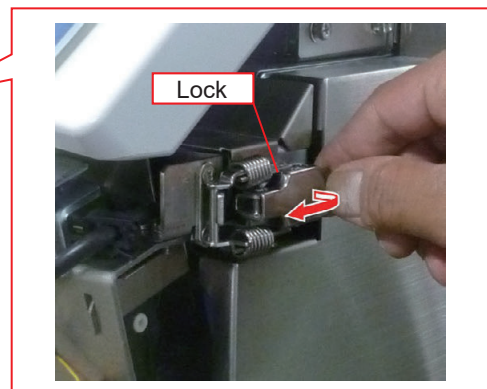
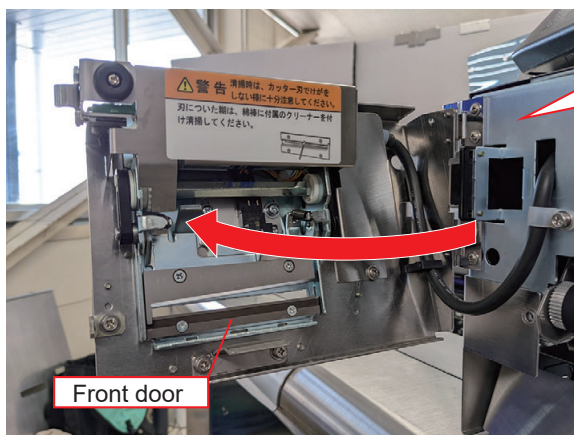

- 4. Place a 0.2 mm-thick card between the thermal head and the printing roller, and push down the head release lever to lock.

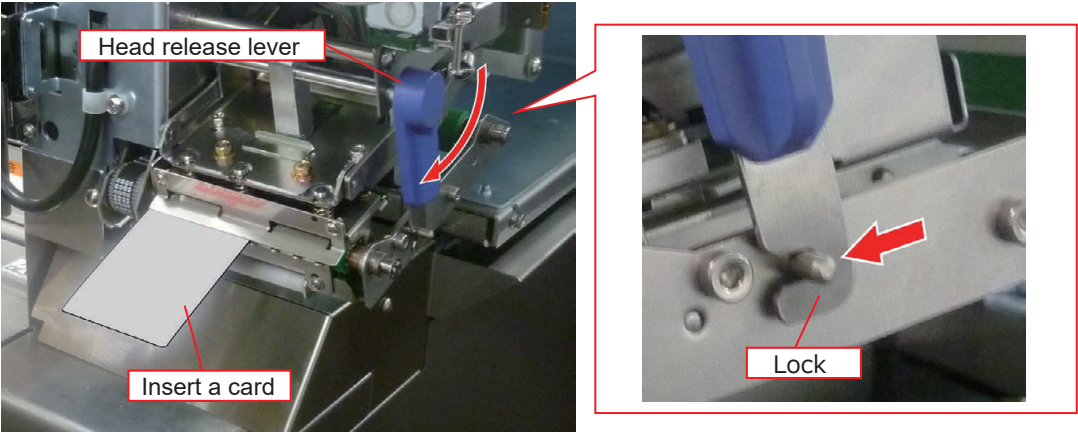

- 5. Loosen the 2 screws and adjust the height that the upper label guide contacts the card.
- 6. Loosen the 2 screws and adjust the height that the gap between the lower label guide and the card is 1.5 mm.

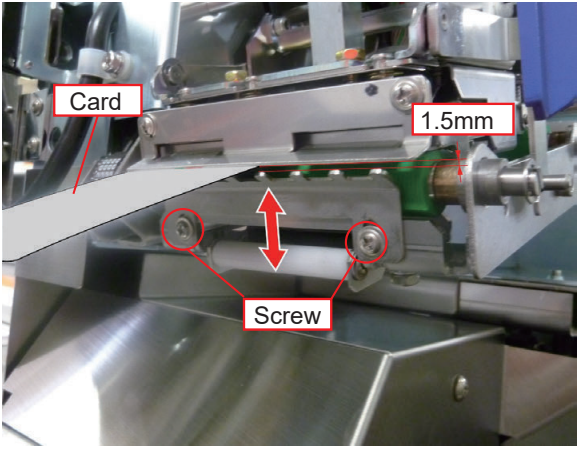
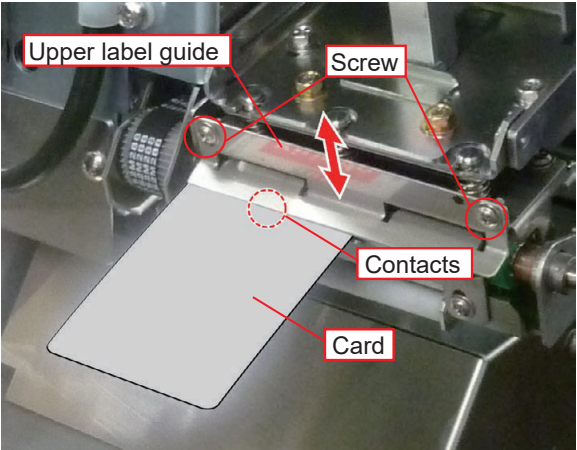

- 7. Close and lock the front door while passing the card through the cutter part.

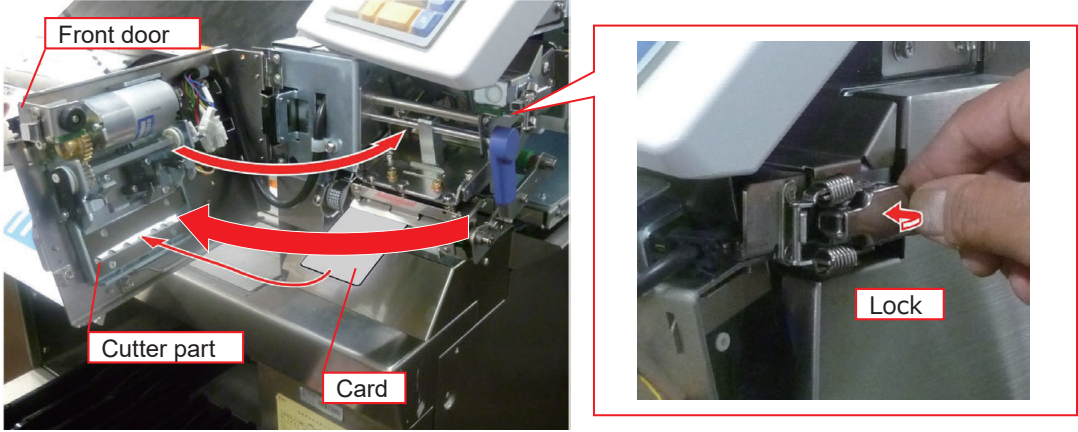

- Loosen the 2 screws and adjust the height that the gap between the cutter unit frame and the card is 1.5 mm.

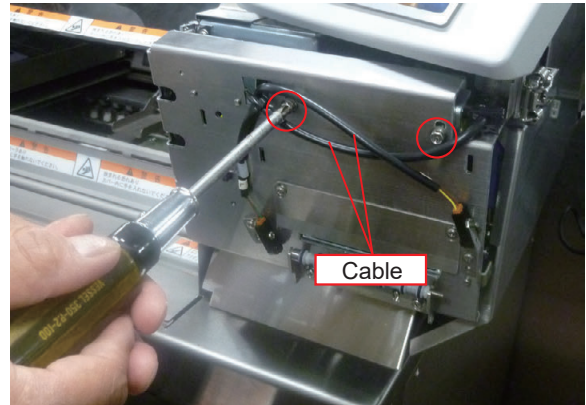
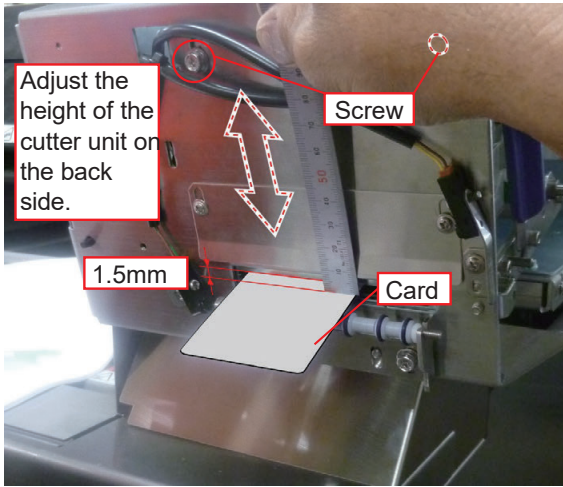

NOTE: The screws are located under the cables, so adjust carefully to avoid damaging the cables.

- Loosen the 2 screws and adjust the height that the gap between the roller bracket and the card is 18 mm.

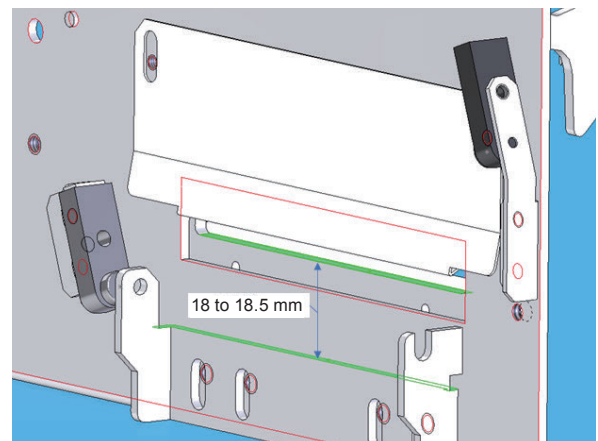
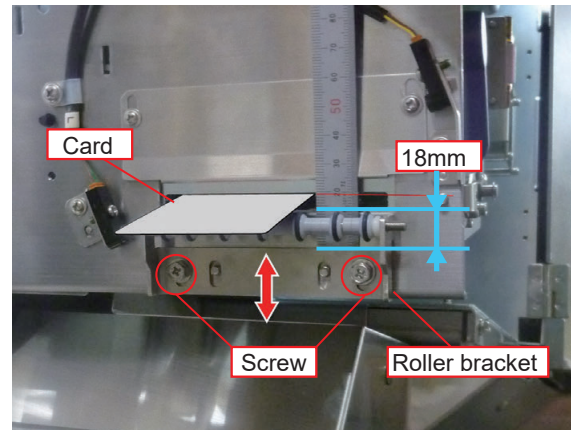

10. Loosen the 2 screws and adjust the height that the top edge of the cutter cover fold is aligned with the bottom edge of the upper side of the cutter part.

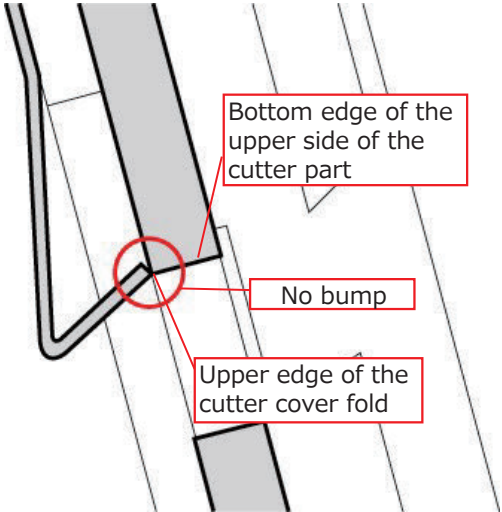
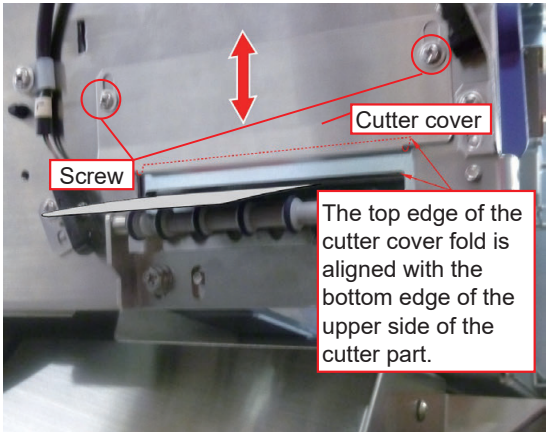

11. Be sure to check from the back side and make sure that there is no bump between the top edge of the cutter cover fold and the bottom edge of the upper side of the cutter part. Any bump may cause the roll paper jams.

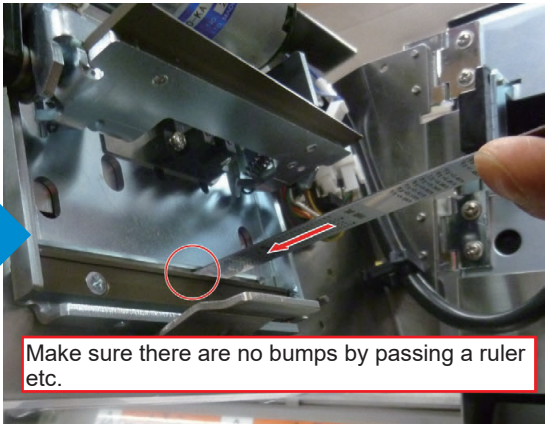
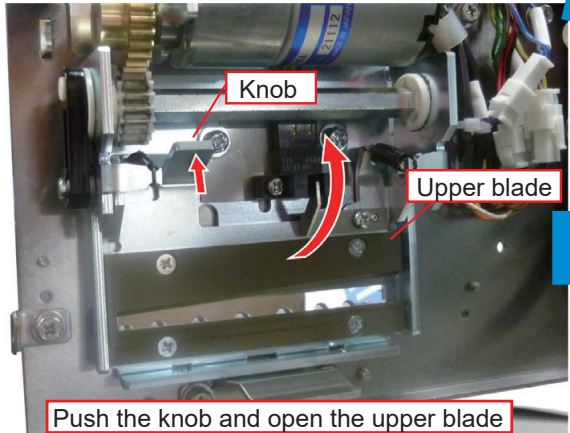
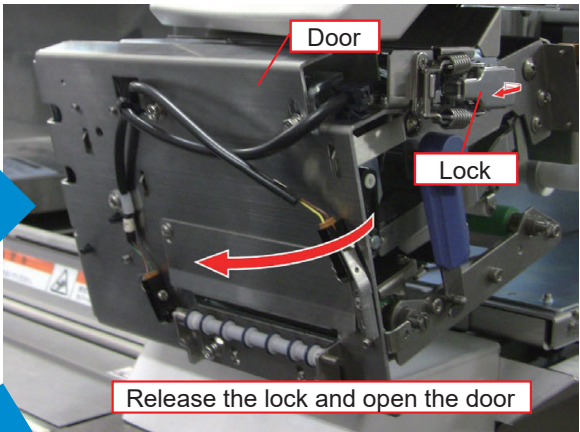
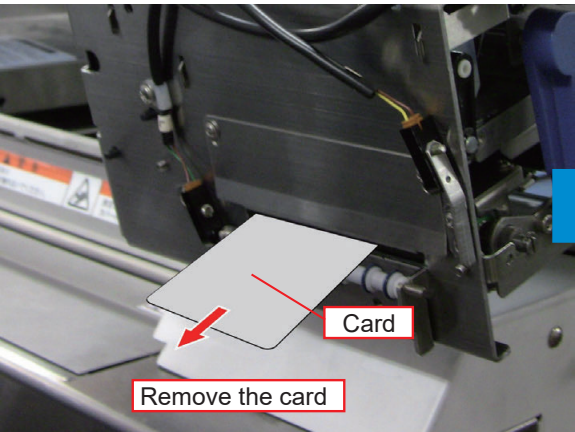

NOTE: Do not touch the cutter blade. It may cause injury.

12. Return the upper blade to the original position.

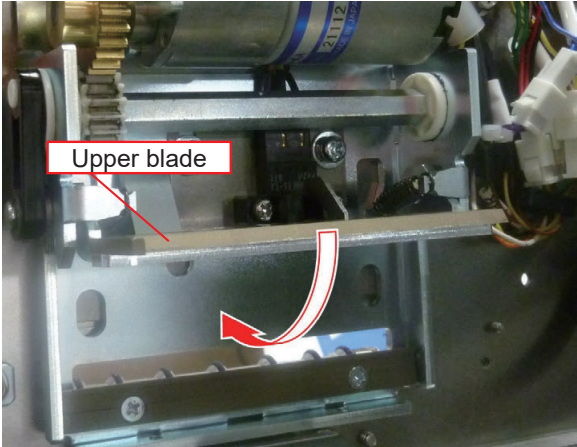

13. Close the front door and lock.

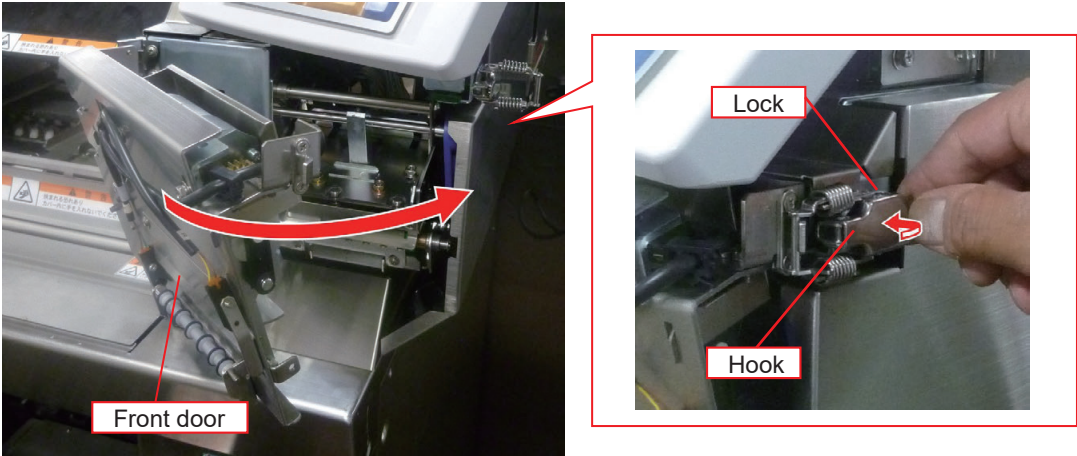

14. Install the front cover and tighten the 3 screws on the left and right side.

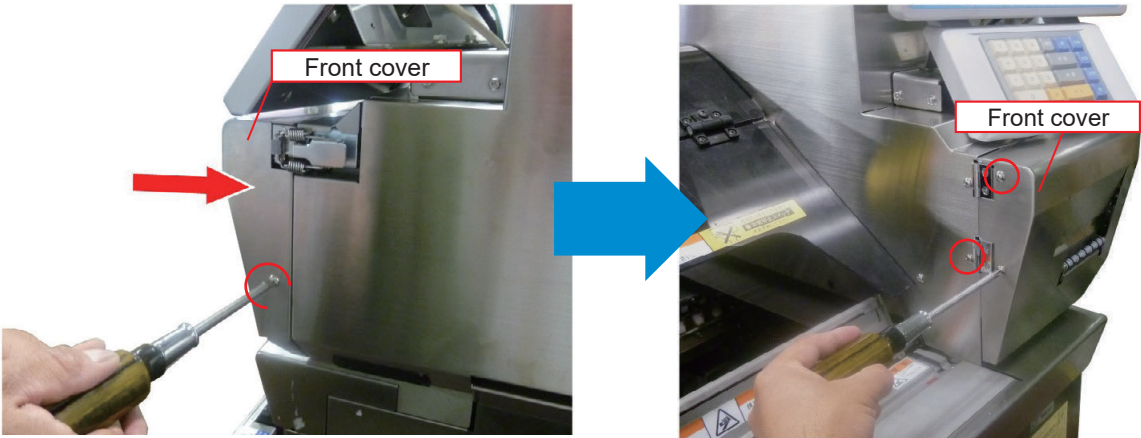

5.4.2 Label guide of the turn roller

1. Loosen the 1 screw with hexagonal wrench and adjust that the distance from the frame to the inside of the outer edge of the label guide to 10 mm.

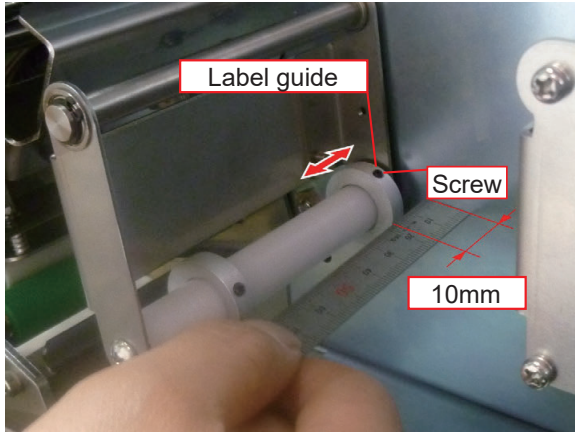

The inside of the label guide is sloped that the distance from the frame to the inner edge is 11 mm.

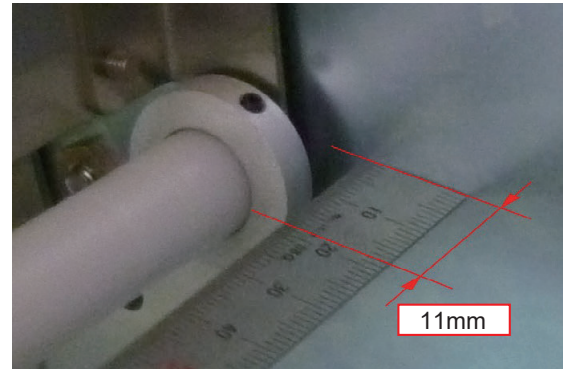

2. Make sure that the gap between the label guide and the stay is 0.5 mm.

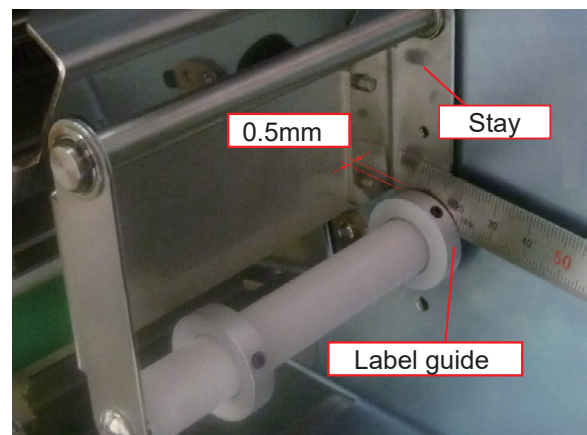

5.4.3 Position of label roll guide

1. Loosen the 1 screw and adjust the distance between the spot plate of the label roll holder and the inside of the label roll guide from 61 to 61.5 mm.

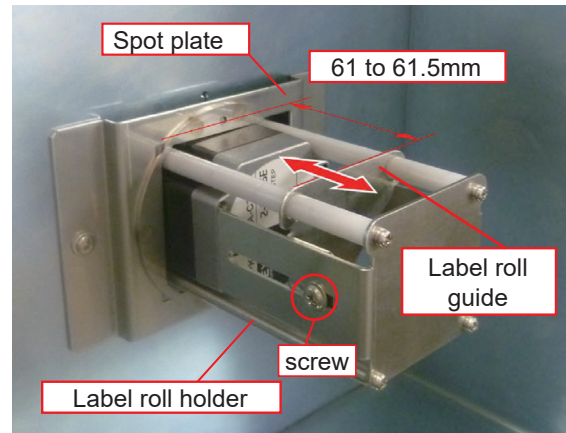

2. After the adjustment, set the label roll and close the door.

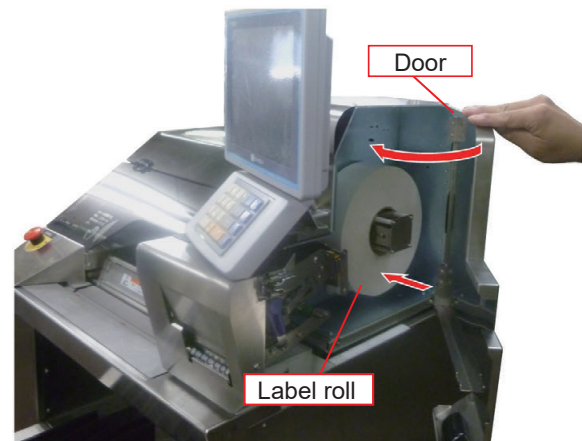

5.5 Periodic replacement / consumable parts

5.5.1 Label equipped printer

Periodic replacement parts (replacement cycle differs depending on usage status.)

No.	Parts Name (Common Name)	Remarks	Expected Damage	Replacement Cycle (approximate)
1	Printing roller	Printer	Deterioration of gripping force Due to wear	2 years and 6 months
2	Thermal head (Single color)	Printer	Missing letter shape due to waste	MTBF about 60 km

Real life of parts differs depending on usage conditions.

STAR thermal paper(same with varnished labels) and YUPO paper(synthetic paper), etc. have shorter run due to wear of the head surface.

The life of thermal head is limited by two factors: Wear of the thermal head and Waste of heat elements.

The life of heat elements corresponds to the number of applied pulses of one hundred million.

As for a thermal head with a resolution of 8 dots/mm, the life reaches its limit first due to wear of the thermal head surface when used for format design of common weighing labels. With a format design that has all black color portions or vertical ruled lines, the heat elements may sometimes reach their life limit first.

**NOTE: MTBF(Mean Time between Failures) is an average interval of failures given as a rough standard.
The numerical values of MTBF and life do not guarantee the corresponding parts.**

5.5.2 Linerless printer

Periodic replacement parts (replacement cycle differs depending on usage status.)

No.	Parts Name (Common Name)	Remarks	Expected Damage	Replacement Cycle (approximate)
1	Printing roller	Printer	Label entrainment due to decreased surface adhesion	20km
2	Cutter unit	Printer	Label cut due to cutter drive weardefective	500,000 times

5.5.3 Wrapping unit

Periodic replacement parts (replacement cycle differs depending on usage status.)

No.	Parts Name (Common Name)	Remarks	Expected Damage	Replacement Cycle (approximate)
1	Green belts	Feeder unit	elongation, cracks, gloss	1 year
2	Cutter blade	Film cutter	Rust, dullness, niced edge	1 year

Parts expected to be needed replacement in 5 years(parts needed in an overhaul)

No.	Parts Name (Common Name)	Remarks	Expected Damage
1	Timing belt in the drive system	Left and right squeezer Feeder drive	Snag, brake, broken teeth
2	Bearing in the linear system	Rear squeezer Ejecting pusher Lift drive Left and right squeezer	Rust, looseness, abnormal noise
3	Bearing in the radial system DU bushing	Each power transmission unit	Rust, looseness, abnormal noise
4	Turn-in roller Receiving bushing	Rear squeezer	Luster, wear, looseness
5	Solenoid	Feeder Cutter Film arm	Wear, powder generation, delay in operation
6	Roll brake (Torque keeper)	Roll holding	Film overrun

Chapter 6 Hardware (Electrical)

6.1 Electrical Unit Board Configuration

⚠ DANGER!

When a worker put his/her hand inside the machine body, be sure to press the emergency stop switch.

⚠ WARNING

- Lock out the power so that it does not turn the key with you.
- During maintenance, attach a tag indicating "Work in progress" or have another operator monitor it.
- Electrical wiring work must be performed by a legally qualified person.

⚠ CAUTION

Pay full attention that the DC 24V power source for the logic system does not turn off even though the emergency stop button is pressed .

⚠ CAUTION

When the fuse blew off, be sure to replace the fuse with the specified one.

⚠ CAUTION

Main board P-1186* -6 and P-1186* -1 can be used for maintenance only when the version number in the * section is C or later.

⚠ CAUTION

When replacing P-1180 (Main board), please follow local regulation on its disposal because it contains lithium battery.

6.1.1 Alignment of PCB

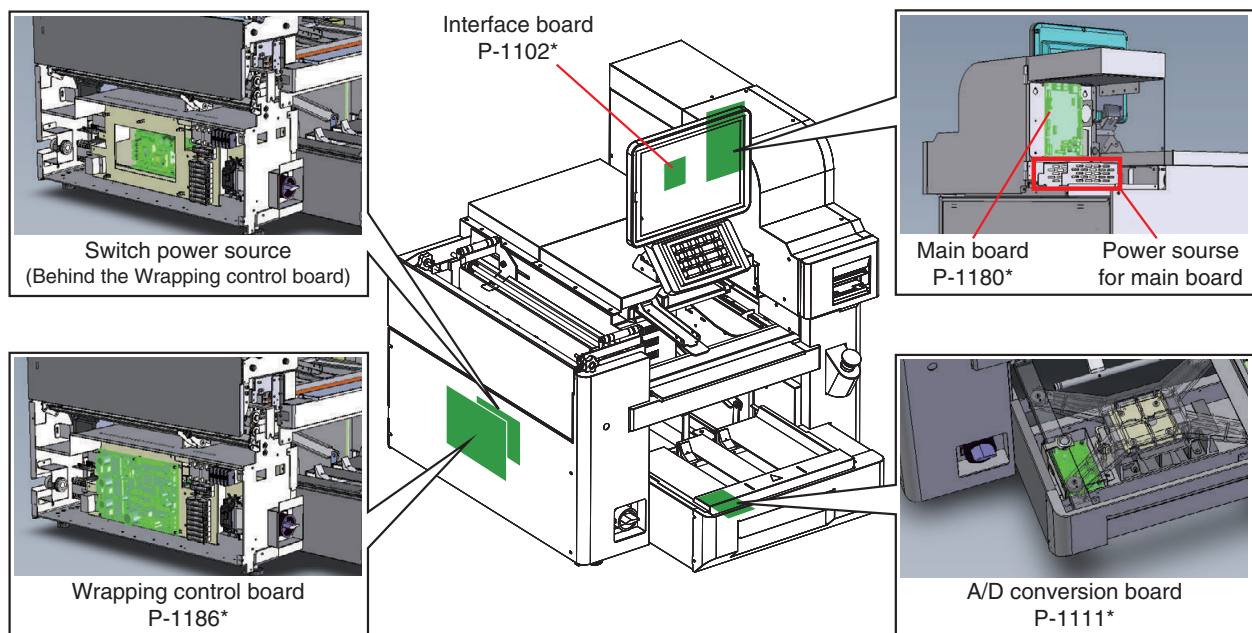

6.1.2 Main board P-1180 (A10)

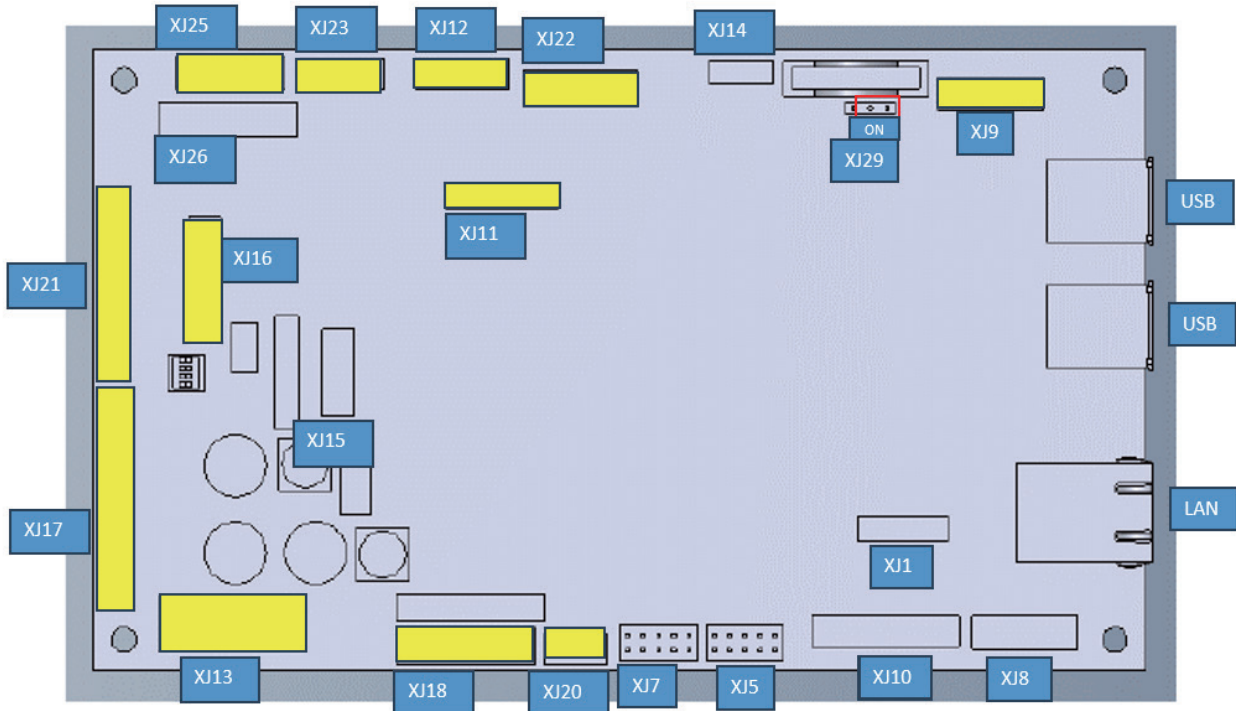

Connector	Connect to		Connector
XJ-7		Thermal head (24 VDC)	
XJ-9		12.1 inch LCD	CN-1, CN-2
XJ-11	-	P-1186 signal and optional wifi power supply (5 VDC)	XJ-16
XJ-12	via X32	Loud speaker	
XJ-13	-	U10 LFP150F-24-J1Y power supply for main (24 VDC)	CN-2, CN-3
XJ-16	via X41	P-1111 (12 VDC)	XJ-1
XJ-18	via M100	Stepper Motor for label feed (24 VDC)	
XJ-20	-	COOLING FAN (12 VDC)	
XJ-22	-	Stepping motor	
XJ-21 *with liner	via X100	head up (S100)	
		label peel (input) (B104)	
		label peel (output) (B105)	
		label detect (input) (B106)	
		label detect (output) (B107)	
XJ-21 *linerless	via X12	head up (S100)	
	via X16,18	label peel (input) (B114)	
	via X16,18	label peel (output) (B115)	
	via X10	label detect (B112)	
	via X19	cutter open (B111)	
	via X15.16	DC Motor for cutter (24 VDC)	
	via X15.16	Cutter originr (5VDC)	
	via X10	label detect (output) (B107)	

Connector	Connect to		Connector
XJ-23	-	P-1186	XJ-16
XJ-25		P-1186 *Receiving Starting signal from XJ-16 XJ23: Status check	XJ-16 XJ-23
XJ-25	via X30	P-1102	P-1102 XJ-9

6.1.3 Wrapping control board P-1186 (A1)

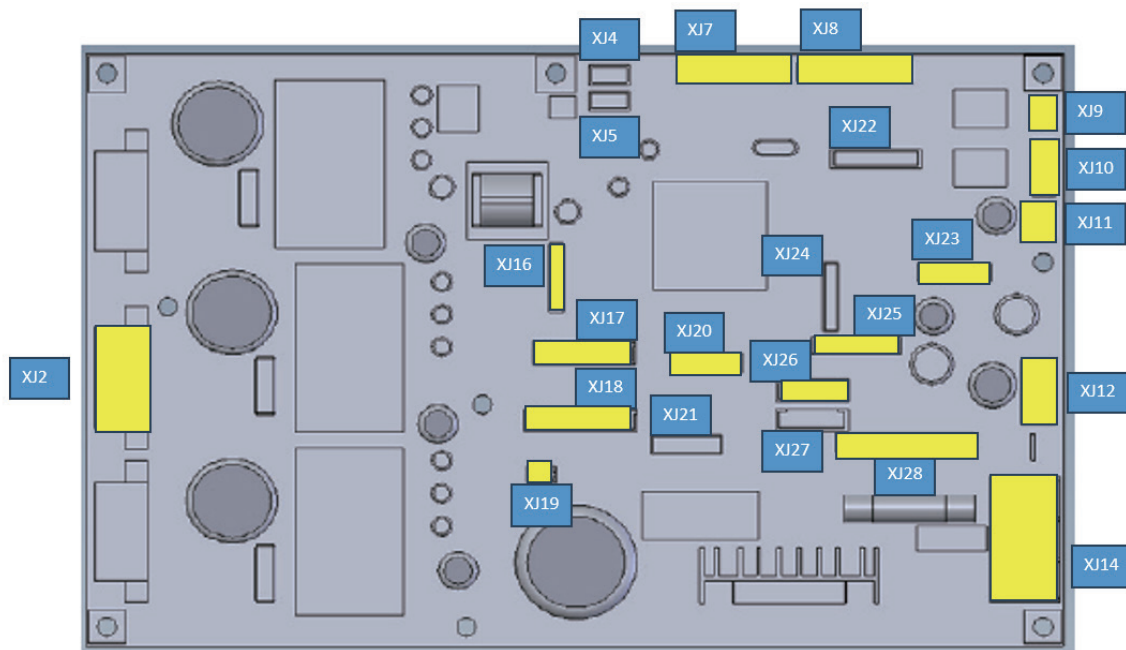

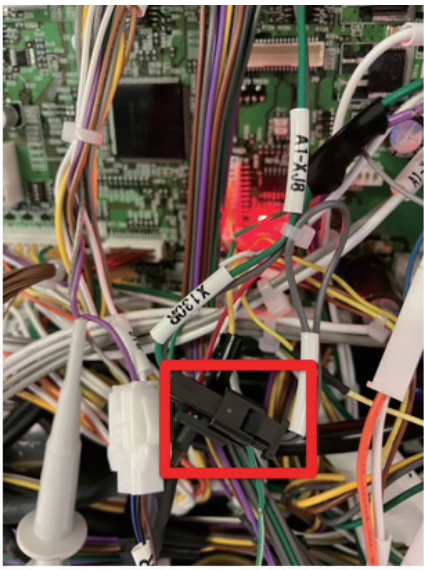
Connector	Connect to		Connector
XJ-2		lift motor	
XJ-7		film existence front/film existence rear/film detect front/film detect rear	
XJ-8	X130R	Machine size identification* LL type: Connect 	
XJ-8	via X111	K1 Auxiliary contact of electromagnetic contact (24 VDC)	K1-13.14
XJ-8	via X100	emergency stop	
XJ-8	via X110, 111	Film feed cover safety SW	
XJ-8	via X120, 121	Film dust cover safety SW	
XJ-8		lift origin	

Connector	Connect to		Connector
XJ-8	via X3	Film feed origin (Film arm) / LR plate origin	
XJ-9		cutter (24 VDC)	
XJ-10	via X2	Film release (arm) rear 75 W	
XJ-10	via X2	Film release (arm) front 75 W	
XJ-11		K1 Interlocking power supply of electromagnetic contact (24 VDC) *U1	A2
XJ-12		U1 LHP300F-24-GY power supply for wrap (DC24V)	CN-2
XJ-14		K1 Interlocking power supply of electromagnetic contact (AC200V) *U1	K1-2.4
XJ-16		P-1180 (A10)	XJ-11,23
XJ-17	via X2	Film feed (Arm) Rear 9.9W	
XJ-17	via X14	FAN for HEATER	
XJ-17	via X21	Fan Heater/Seal Heater SSR	
XJ-18		Cranp Solenoid (Front center / Rear LR / Front LR / Rear center)	
XJ-18	via X2	Film feed (Arm Front) 9.9W	
XJ-19		K1 Excitation coil of electromagnetic contact (24 VDC)	A1,2
XJ-20		P-1006*-8 (A2)	
XJ-23		P-1180 (A10)	XJ-25
XJ-25	R1	Thermistor for seal heater	
XJ-25	R141	Thermistor for fan heater	
XJ-26		P-1180(A10)	XJ-25
XJ-28		infeed hand insert (input)	
XJ-28		plate limit	
XJ-28	via X3	eject hand insert/eject detection (input)	
XJ-28	via X4	infeed hand insert/eject hand insert/eject detection (output)	

6.1.4 Motor driver board P-1006 (A2)

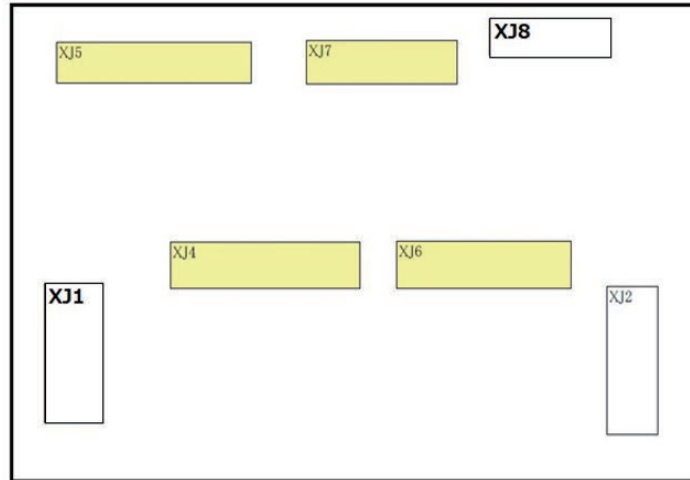

Connector	Connect to		Connector
XJ-5		FAN for HEATER (24 VDC)	
XJ-4		LR Plate motor (24 VDC)	
XJ-6	-	Film feed motor (24 VDC)	
XJ-7	-	P-1186 (5 VDC / 24 VDC)	XJ-20

6.1.5 Interface board P-1102 (A30)

Connector	Connect to		Connector
XJ-4	-	Touch key	
XJ-6	-	Touch panel	
XJ-9		P-1186	XJ-25

6.1.6 A/D conversion board P-1111 (A40)

Connector	Connect to		Connector
XJ-1	via X41	P-1180	XJ-16
LAND	-	Red: +5V White:GND Blue: S- Green: S+ Black: FG	

6.1.7 Front side of the machine

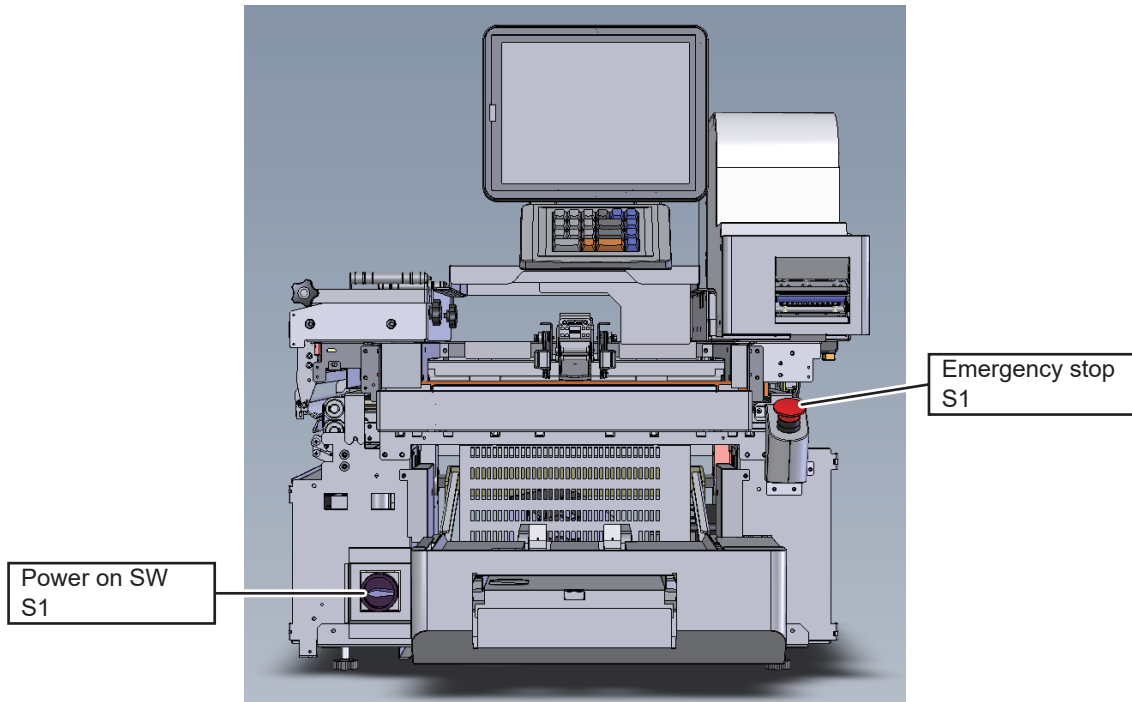

No.	Parts Name	Function
S1	Power on SW	Main power switch of the machine.
S1	Emergency stop	Pressing the switch activates the electromagnetic contactor and shuts off the power source for the drive system. To recover the power source, turn the switch clockwise.

6.1.8 Left side of the machine

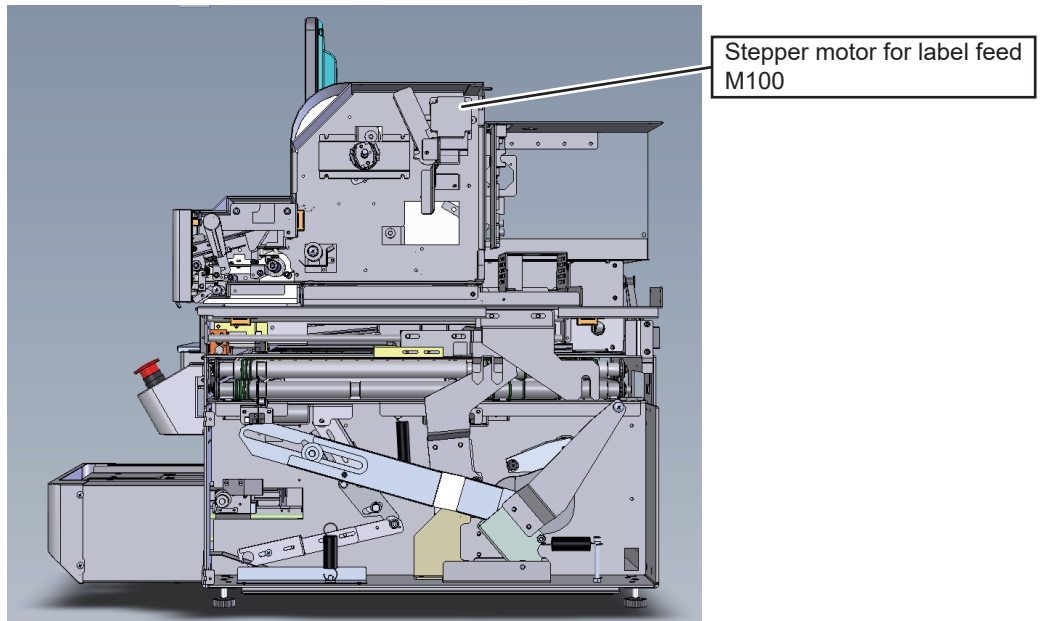

No.	Parts Name	Function
M100	Stepper motor for label feed	

6.1.9 Back side of the machine

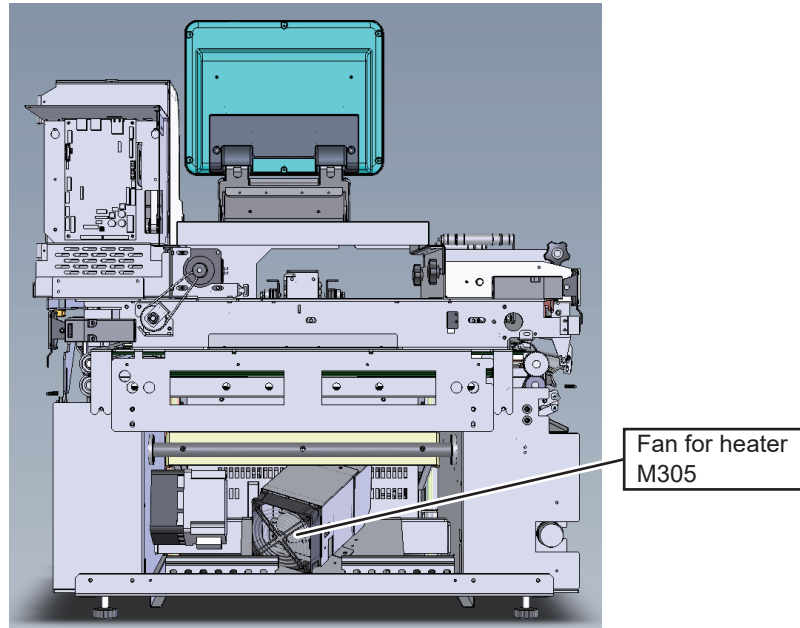

No.	Parts Name	Function
M305	Fan for heater	

6.1.10 Right side of the machine

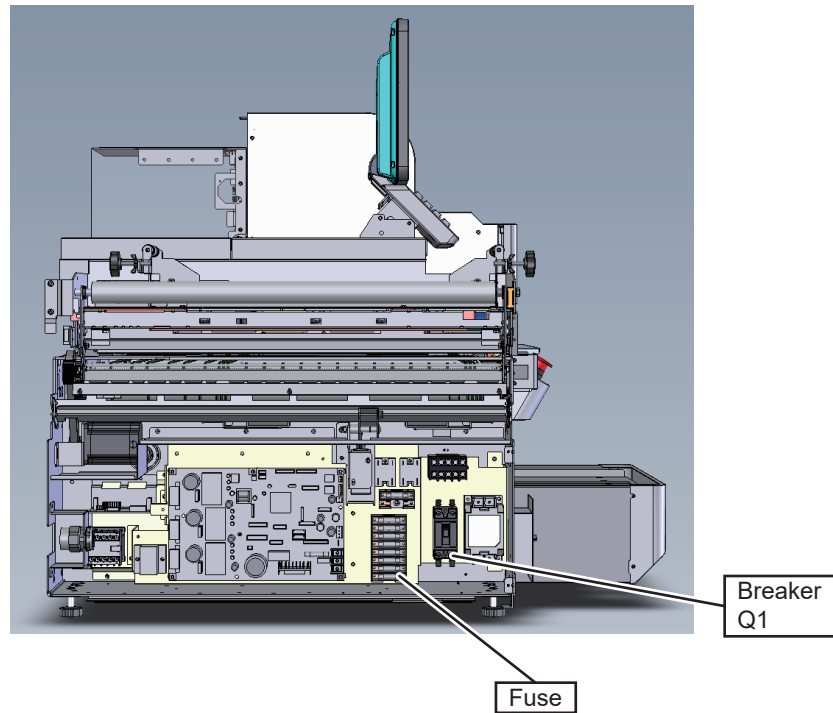

No.	Parts Name	Function
Q1	Breaker	Built-in circuit breaker of the machine. It uses Type NV-L22FYC 20A 2P 100-200V 30MA. Rating Overcurrent protection: 20A, Leakage protection: 30 mA
	Fuse	F1, F2: Switch power source F3, F4: Interlocking cord with the operation unit F5, F6: Seal heater F7, F8: Fan heater

6.2 Sensor Location

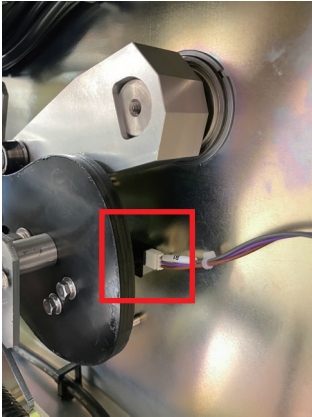

B1 lift origin

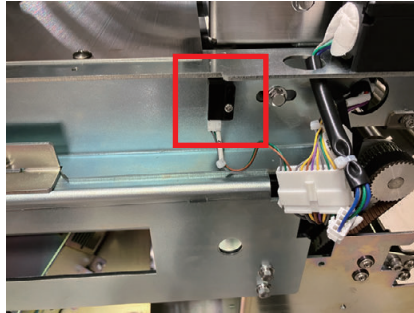

B2 LR plate origin

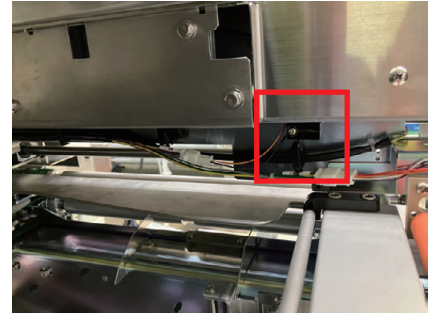

B4 eject hand insert

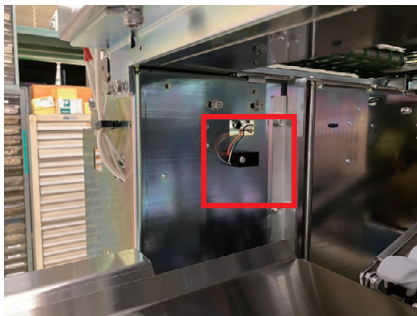

B6 infeed hand insert

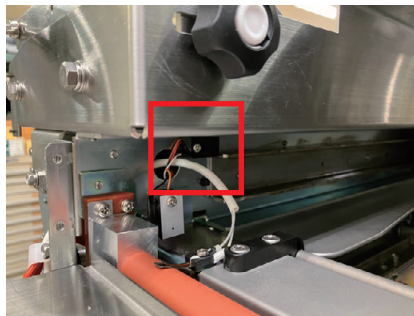

B7 eject hand insert

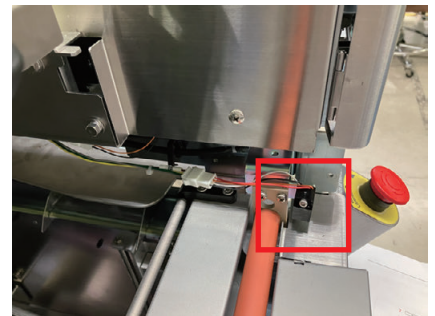

B8 eject detection

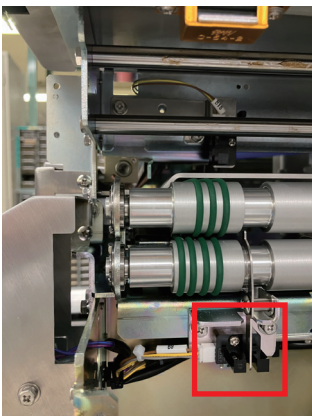

B9 film existence front

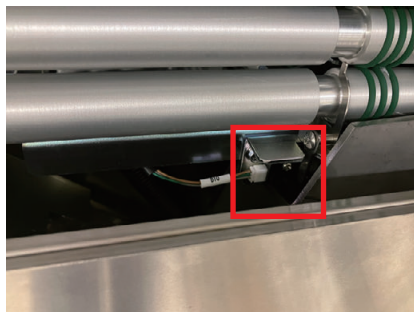

B10 film existence rear

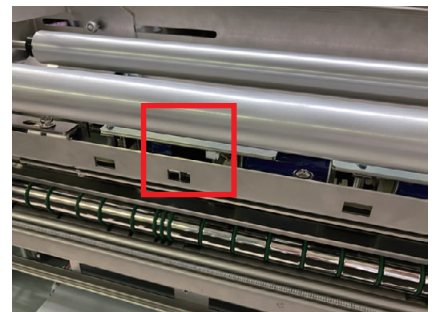

B11 film feed origin



B14 film detect front

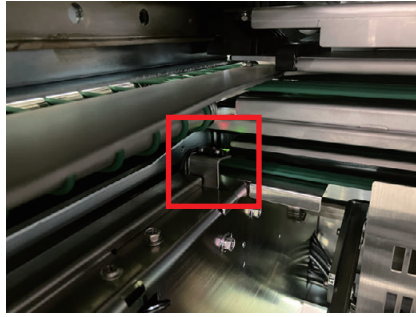

B15 film detect rear

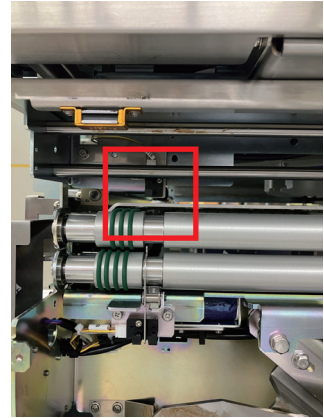

B16 plate limit

Chapter 7 Troubleshooting

7.1 Operation as IP (Scale and Printer)

This section describes the procedure to use the wrapper as an IP (scale or printer only) in case that the wrapper is disabled due to a trouble, etc.

- 1 Turn OFF the power of the wrapper unit.
- 2 Turn ON the power of the wrapper unit as shown in Fig. 1.
- 3 With the condition above, press the emergency stop button of the wrapper unit.
- 4 With the condition above, press the return key of the wrapper unit for 11 times. The screen in fig. 1 will be released and returned to the normal screen.
- 5 The wrapper unit can be used as an IP (weigh price labeler).

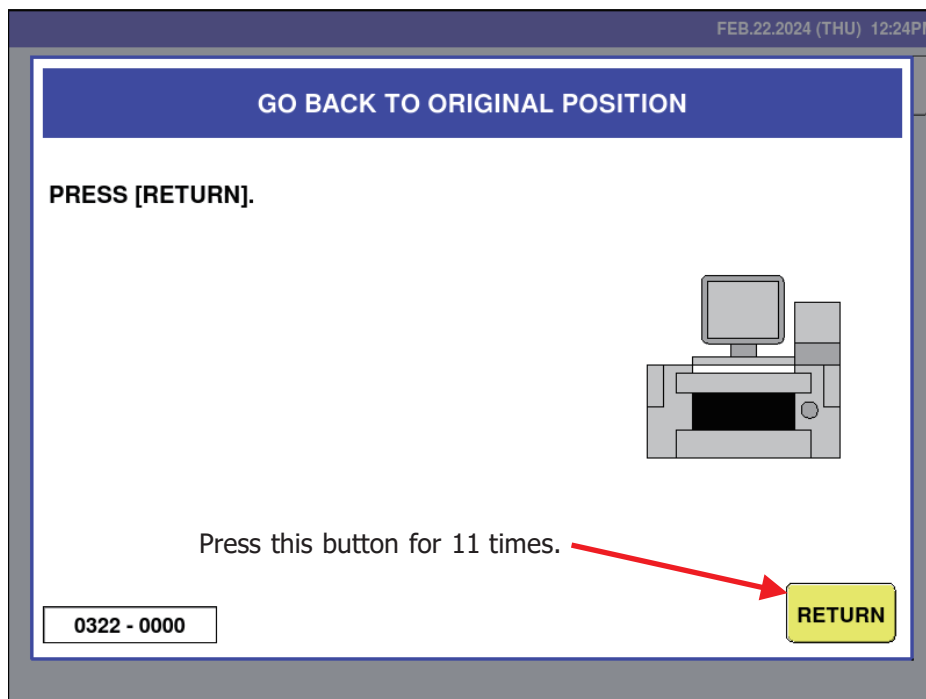

Fig. 1 Screen when the power is ON.

7.2 Error Message

7.2.1 Error Display

When the machine detects an error, the error message and error number shown below are displayed.

Depending on the error type, the machine may be recovered by performing only button operations, simple procedure and button operations, or maintenance such as parts replacement.

When there is an inquiry from the user, be sure to check the error number. The action to be taken may differ even if the messages are alike.

The error number consists of a main number (four digits) and sub number (four digits). If there is only one type of a sub number, only the main number is shown on the error message list.

The wrapper unit can be used as an IP (weigh price labeler).

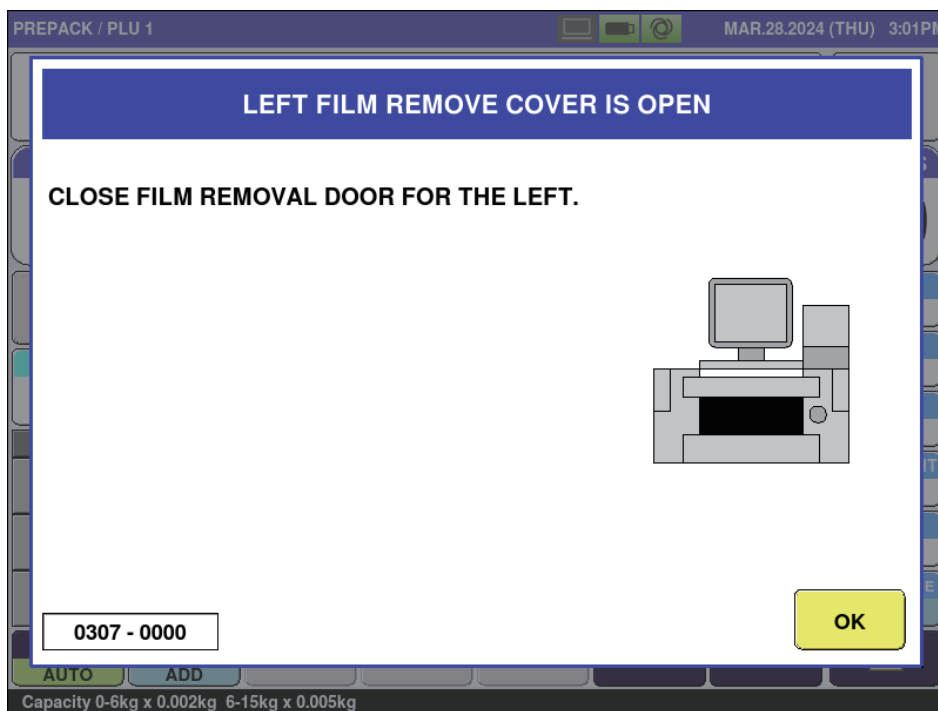

Fig. An example of an error display

7.3 Error List

7.3.1 Error relates to System (Code 100s)

ID NO.	TITLE	ERROR CONTENT	SOLUTION
0105	INITIALIZATION FAILED	The machine failed to initialize the memory. After the board is replaced, the memory initialization has not been implemented.	[OK] Implement the memory initialization.
0106	BATTERY IS FAULT	Either the battery is consumed or switch for the battery is OFF.	[OK] When the battery switch is OFF, turn ON the battery switch. When the battery switch is ON, as the battery is consumed, the replacement of the board is necessary. (The battery is embedded to the board.)
0107	TOUCH SCREEN ADJUSTMENT IS NOT COMPLETED YET	The adjustment of the touch panel is not completed. After the board is replaced, the adjustment of touch panel is not implemented yet.	[OK] Implement the adjustment of the touch panel.
0108	CLOCK SETTING IS NOT COMPLETED YET	The setting of the clock is not completed. After the board is replaced, the setting of the clock has not been implemented yet.	[OK] The setting of the clock is necessary.
0109	PRINTER 1 INITIALIAZATION WAS NOT DONE YET	The initialization of printer is not completed. After the board is replaced, the initialization of the printer has not mented yet. The initialization of the printer is necessary. <SUBERROR No.> 0000: Printer 1 0001: Printer 2 0002: Printer 2 0003: Printer 4	[OK]
0110	MACHINE SETTING IS NOT COMPLETED	Machine setting is not completed. After the board is replaced, the setting of the machine has not been implemented yet.	[OK] Machine setting is necessary.
0111	THE DISPLAY CONFIRMATION IS NOT COMPLETED	The display confirmation setting has not been completed.	[OK] Configure the display setting.

ID NO.	TITLE	ERROR CONTENT	SOLUTION
0112	CONFIRM OPERATION OF THE TACTILE KEYBOARD	Operation of the tactile keyboard is not confirmed yet. After the board is replaced, the confirmation of the tactile keyboard has not been implemented yet.	[OK] Confirmation of operation of the tactile keyboard is necessary.
0114	DATA COMPOSITION IS DIFFERENT	Data composition is different. The database version is not the proper one to be used by the program.	[OK] The database version that the program can use and the actual database version is not same. Memory initialization is necessary. * When you implement the memory initialization, database will be re-built with the proper version that the program can use.
0116	THE COUNTRY HAS NOT BEEN SELECTED	The selection of the country is not completed. After the board is replaced, the setting of the country has not been implemented yet.	[OK] The country setting is necessary.
0117	CF CARD IS NOT INSERTED	CF card is not inserted. This message only appears when the saving place of TOTAL data is setup to CF card.	[OK] Insert CF card.
0118	USB MEMORY STICK IS NOT INSERTED	USB memory stick is not inserted. This message only appears when the saving place of TOTAL data is setup to USB memory.	[OK] Insert USB memory.
0192	WM-MICRO TYPE IS DIFFERENT	The model of WM-MICRO type (L type/LL type) is different.	[OK]

7.3.2 Error relates to Memory (Code 200s)

ID NO.	TITLE	ERROR CONTENT	SOLUTION
0202	PLU MASTER IS NOT PROGRAMMED	PLU that was called up is not programmed in the PLU master. Called PLU does not exist in the internal memory. The number of PLU that was called up appears on the display	[OK]
0203	POP MASTER IS NOT PROGRAMMED	POP message that was called up is not programmed in the POP master. Called POP message does not exist in the internal memory.	[SET] → Only releasing the error message. [DELETE] → Deletes the POP message of the PLU.
0210	TRAY MASTER IS NOT PROGRAMMED	Tray No. that was called up is not programmed in the Tray master. Called Tray No. does not exist in the internal memory.	[OK]
0212	FREE MSG. 1 MASTER ISN'T PROGRAMMED	Free Message 1 that was called up is not programmed in the Free Message 1 master. Called Free Message 1 No. does not exist in the internal memory.	[SET] → Only releasing the error message. [DELETE] → Deletes the Free Message 1 of the PLU.
0213	FREE MSG. 2 MASTER ISN'T PROGRAMMED	Free Message 2 that was called up is not programmed in the Free Message 2 master. Called Free Message 2 No. does not exist in the internal memory.	[SET] Only releasing the error message. [DELETE] Deletes the Free Message 2 of the PLU.
0214	FREE MSG.3 MASTER ISN'T PROGRAMMED	Free Message 3 that was called up is not programmed in the Free Message 3 master. Called Free Message 3 No. does not exist in the internal memory.	[SET] → Only releasing the error message. [DELETE] → Deletes the Free Message 3 of the PLU.
0215	FREE MSG.4 MASTER ISN'T PROGRAMMED	Free Message 4 that was called up is not programmed in the Free Message 4 master. Called Free Message 4 No. does not exist in the internal memory.	[SET] → Only releasing the error message. [DELETE] → Deletes the Free Message 4 of the PLU.
0216	FREE MSG.5 MASTER ISN'T PROGRAMMED	Free Message 5 that was called up is not programmed in the Free Message 5 master. Called Free Message 5 No. does not exist in the internal memory.	[SET] → Only releasing the error message. [DELETE] → Deletes the Free Message 5 of the PLU.
0219	STORE MASTER IS NOT PROGRAMMED	The store you called is not registered.	[OK]→ Error release Reconfirm the Free Message 5 master call number. Add the Free Message 5 master.
2000	TARE LIMIT OVER	The tare setting exceeds the upper limit. (MAX 5.998 kg)	[OK] Check the tare setting.
0226	AMOUNT OF INTERNAL MEMORY IS SHORT	Amount of internal memory does not enough room. - When showing the lists, the machine failed to reserve the memory for the list data. - Full-Memory Error at database occurred.	[OK]

ID NO.	TITLE	ERROR CONTENT	SOLUTION
0227	AMOUNT OF INTERNAL MEMORY FOR TOTAL IS FULL	Amount of internal memory for the total becomes full. Since the data for TOTAL is full, it could not add new record. Full-Memory Error at database occurred when the machine tried to add new TOTAL record.	[OK]
0229	FILE SYSTEM IS ABNORMAL	File system has some problems. Access to the database failed. <SUB ERROR No.> 1: Check for database corruption and notify that it has been restored with the backup data.	[OK] It is necessary to do Memory Initialization.
0266	FILE INPUT ERROR	It failed to input the file. It failed to input the data at the file input/output operation. <SUB ERROR No.> 1: SRAM delete 2: Master file delete	[OK]
0267	FILE OUTPUT ERROR	It failed to output the file. It failed to output the data at the file input/output operation. <SUB ERROR No.> 0: Master file output 1:SRAM output 2: All data output	[OK]
0268	FILE DELETE ERROR	It failed to delete the file. It failed to delete the data in USB at the file input/output operation. <SUB ERROR No.> 0: Master file delete 1: SRAM delete 2: Each folder delete 3: All folder delete	[OK]
0271	INITIALIZE ERROR	It failed to initialize the file. It failed to initialize the data at the file input/output operation.	[OK]
0286	EXTRA MSG.1 MASTER IS NOT PROGRAMMED	The Extra Message 1 master you called is not registered.	[SET] → Delete the Extra Message 1 number in the product master. [DELETE] → Perform error release only.
0287	INGREDIENT MASTER IS NOT PROGRAMMED	The Ingredient master you called is not registered. The master does not exist in the internal master.	[SET] → Delete the Ingredient number in the product master. [DELETE] → Perform error release only.
0288	EXTRA MSG.3 MASTER IS NOT PROGRAMMED	The Extra Message 3 master you called is not registered. The master does not exist in the internal master.	[SET] → Delete the Extra Message 3 number in the product master. [DELETE] → Perform error release only.
0290	TARE WEIGHT IS 0kg	The tare weight is not set.	[OK] Set the tare weight.
0292	TARE WEIGHT IS 0lb	The tare weight is not set.	[OK] Set the tare weight.

ID NO.	TITLE	ERROR CONTENT	SOLUTION
0293	FUNCTION KEY ERROR	Failed to display the function key.	[OK] Return to the menu screen and display the production screen again. Restart the machine.
0294	FREE MSG.6 ISN'T PROGRAMMED	The Free Message 6 master you called is not registered. The master does not exist in the internal master.	[SET] → Delete the Free Message 6 number in the PLU master. [DELETE] → Perform error release only.
0295	FREE MSG.7 ISN'T PROGRAMMED	The Free Message 7 master you called is not registered. The master does not exist in the internal master.	[SET] → Delete the Free Message 7 number in the PLU master. [DELETE] → Perform error release only.
0296	FREE MSG.8 ISN'T PROGRAMMED	The Free Message 8 master you called is not registered. The master does not exist in the internal master.	[SET] → Delete the Free Message 8 number in the PLU master. [DELETE] → Perform error release only.
0298	FREE MSG.10 ISN'T PROGRAMMED	The Free Message 10 master you called is not registered. The master does not exist in the internal master.	[SET] → Delete the Free Message 10 number in the PLU master. [DELETE] → Perform error release only.
4201	FREE MSG.11 ISN'T PROGRAMMED	The Free Message 11 master you called is not registered. The master does not exist in the internal master.	[SET] → Delete the Free Message 11 number in the PLU master. [DELETE] → Perform error release only.
4202	FREE MSG.12 ISN'T PROGRAMMED	The Free Message 12 master you called is not registered. The master does not exist in the internal master.	[SET] → Delete the Free Message 12 number in the PLU master. [DELETE] → Perform error release only.
4203	FREE MSG.13 ISN'T PROGRAMMED	The Free Message 13 master you called is not registered. The master does not exist in the internal master.	[SET] → Delete the Free Message 13 number in the PLU master. [DELETE] → Perform error release only.
4204	FREE MSG.14 ISN'T PROGRAMMED	The Free Message 14 master you called is not registered. The master does not exist in the internal master.	[SET] → Delete the Free Message 14 number in the PLU master. [DELETE] → Perform error release only.
4205	FREE MSG.15 ISN'T PROGRAMMED	The Free Message 15 master you called is not registered. The master does not exist in the internal master.	[SET] → Delete the Free Message 15 number in the PLU master. [DELETE] → Perform error release only.
4206	COUPON MASTER IS NOT PROGRAMMED	The coupon master you called is not registered. The master does not exist in the internal master.	[SET] → Delete the Coupon number in the PLU master. [DELETE] → Perform error release only.

7.3.3 Error relates to Pre-check (Code 300s)

ID NO.	TITLE	ERROR CONTENT	SOLUTION
0301	EMERGENCY SWITCH HAS BEEN PUSHED	Emergency switch is pressed when the machine started moving.	[OK] and release Emergency switch
0306	RIGHT SIDE COVER IS OPEN	Right side cover is open when the machine started moving.	[OK] and close the right side cover
0307	LEFT SIDE COVER IS OPEN	Left side cover is open when the machine started moving.	[OK] and close the left side cover
0312	LABEL IS REMAINING	Label is remaining when the machine started moving. <SUB ERROR No.> 0: Printer 1: Except for printer (Ex. Applicator) *The wrapper picture will not be shown with Uni-7.	[OK] and remove the label
0313	PRINTER THERMAL HEAD IS UP	Thermal head is up when the machine started moving. <SUB ERROR No.> 0: IP 1:WM	[OK] and set the thermal head
0316	MARK DOWN PRICE IS MORE THAN ORIGINAL PRICE	Mark down price is more than original price.	[OK]
0318	MARK DOWN UNIT PRICE IS MORE THAN ORIGINAL PRICE	Mark down unit price is more than original price.	[OK]
0321	PRICE IS NOT PROGRAMMED	Price is not programmed. <SUB ERROR No.> 0: No Price 1: No Weight 2: No Unit Price 3: When campaign is [9:S.P. ARB.], the quantity is not matching the programmed quantity in campaign setting. (Ex. Unit is set to 2 in the campaign but actual quantity is 3.) When it is set not to show error message at [Error Process] even price is 0, this will not appear.	[OK]
0322	The machine moves the parts to original (home) position.	The machine moves the parts to original (home) position. It appears only when the machine is turned ON.	[OK]

ID NO.	TITLE	ERROR CONTENT	SOLUTION
0325	WEIGT OVER LIMIT	Weight value is out of the set limitation (Over or Under). <SUB ERROR No.> 0: Actual weight is out of range 1: Fixed Weight is out of range	<ul style="list-style-type: none"> - When actual weight is out of range: [PRINT]: Will not be an error [STOP]: Will not check the weight until the item is called up next time Membrane key is pressed: Error display will close - Fixed Weight is out of range: [OK] Please check the weight value.
0337	ORDER IS DELETED	The previous data has been erased.	Press the emergency stop button, remove the product on the wrapper, and then press the [RETURN] button.
0339	LOWER VALUE IS LESS THAN FIXED WEIGHT	Under limitation is set to less than fixed weight.	<p>[EXEC]: It overwrites the lower limitation with the fixed weight and release the error.</p> <p>[STOP]: Release the error. Confirm the under limitation value and fixed weight value.</p>
0341	PRODUCT IS REMAINING ON THE LIFT	The product is remaining on the lift. The operation that was prohibited during the production was implemented when there was an item in produce around the scale to the lift.	<p>[OK] Discharge the item inside by pressing PLU key, and then start the operation.</p>
0342	POS CODE IS NOT PROGRAMMED	POS CODE is not programmed. When it is set [NO LABEL PRINT] at [Error Process] when POS Code is not programmed, this will appear. Program POS Code of items at the programming menu.	[OK]
0349	STORE No. IS NOT SET	The store number has not been called. This error occurs during store changeover when an attempt is made to move to a production operation when the product call has been completed but the store call has not been completed.	<p>[OK] Enter the store number and press the [STORE] function key.</p>
0350	TRAY No. IS NOT PROGRAMMED	Tray No. is not programmed to the product. When you operate [WRAP] or [WRAP + PRINT], selecting the tray is necessary. When you operate only [PRINT], change the [WRAP MODE] to [PRINT]. When you operate [WRAP] or [WRAP +PRINT], selecting the tray is necessary.	[OK]

ID NO.	TITLE	ERROR CONTENT	SOLUTION
0351	LABEL IS REMAINING	Label is remaining. The operation that was prohibited during the production was implemented when there was an item in produce around the lift to the discharging part.	[OK] Wait until the item is discharged and remove the item and a label at the printer.
0355	TRAY No. IS NOT PROGRAMMED	Tray No. is not programmed. The tray No. that is programmed at PLU does not exist in the tray master. Select the tray No. when you operate [WRAP] or [WRAP+PRINT]. * When the tray No. is not programmed in the tray master, it is necessary to program the tray additionally. When you operate only printing, change the [WRAP MODE] to [PRINT]. When you operate [WRAP] or [WRAP +PRINT], selecting the tray is necessary.	[OK]
0361	POWER IS ON	It is the error for recording the log for turning on the machine. No error display	[OK]
0383	THE WEIGHING PLATTER IS NOT SET	The weighing platter is not installed. The return operation has been performed without the weighing platter installed.	Install the weighing platter and then press the RETURN button. Restart the machine to make sure the weighing platter is installed correctly.
0392	CHECK EXPIRY DATE	Check the expiry date. The expiry date for production is a past date.	[OK] Check the pack date and expiry date of the product to be produced.
0396	NO USB MEMORY	USB Memory stick is not inserted. USB Memory stick is not inserted or the inserted USB Memory stick cannot be recognized. (Only when saving TOTAL. Except for this, it becomes Error 396.)	[OK] Insert the USB Memory stick. If USB Memory stick is already inserted, retry it again.
3040	INCORRECT MARKDOWN AMOUNT	The markdown price is abnormal. The price is "0" as a result of markdown.	[OK] Set the correct markdown price.
3048	THE CUTTER BLADE NEEDS TO BE REPLACED	The cutter blade needs to be replaced. The number of times the cutter of the linerless label printer has been used exceeds the set number of times.	[OK] Contact your ISHIDA service agent.

ID NO.	TITLE	ERROR CONTENT	SOLUTION
3049	THE PLATEN ROLLER NEEDS TO BE REPLACED	The travel distance of the platen roller of the linerless label printer has exceeded the set distance.	[OK] Contact your ISHIDA service agent.
3050	CUTTER IS NOT AT HOME POSITION	The cutter of the linerless label printer is not at the home position.	Press the [CUTTER OPERATION] button.
3051	CUTTER COVER ERROR	The cutter cover of the linerless label printer is open.	[OK] Close the cutter cover.
3052	MAINTENANCE	The set maintenance date has been reached.	[OK] Contact your ISHIDA service agent.

7.3.4 Error related to Wrapper (Code 400s to 500s)

1. WRAPPING UNIT ERRORS

1.1 WRAPPER IS NOT CONNECTED (401)

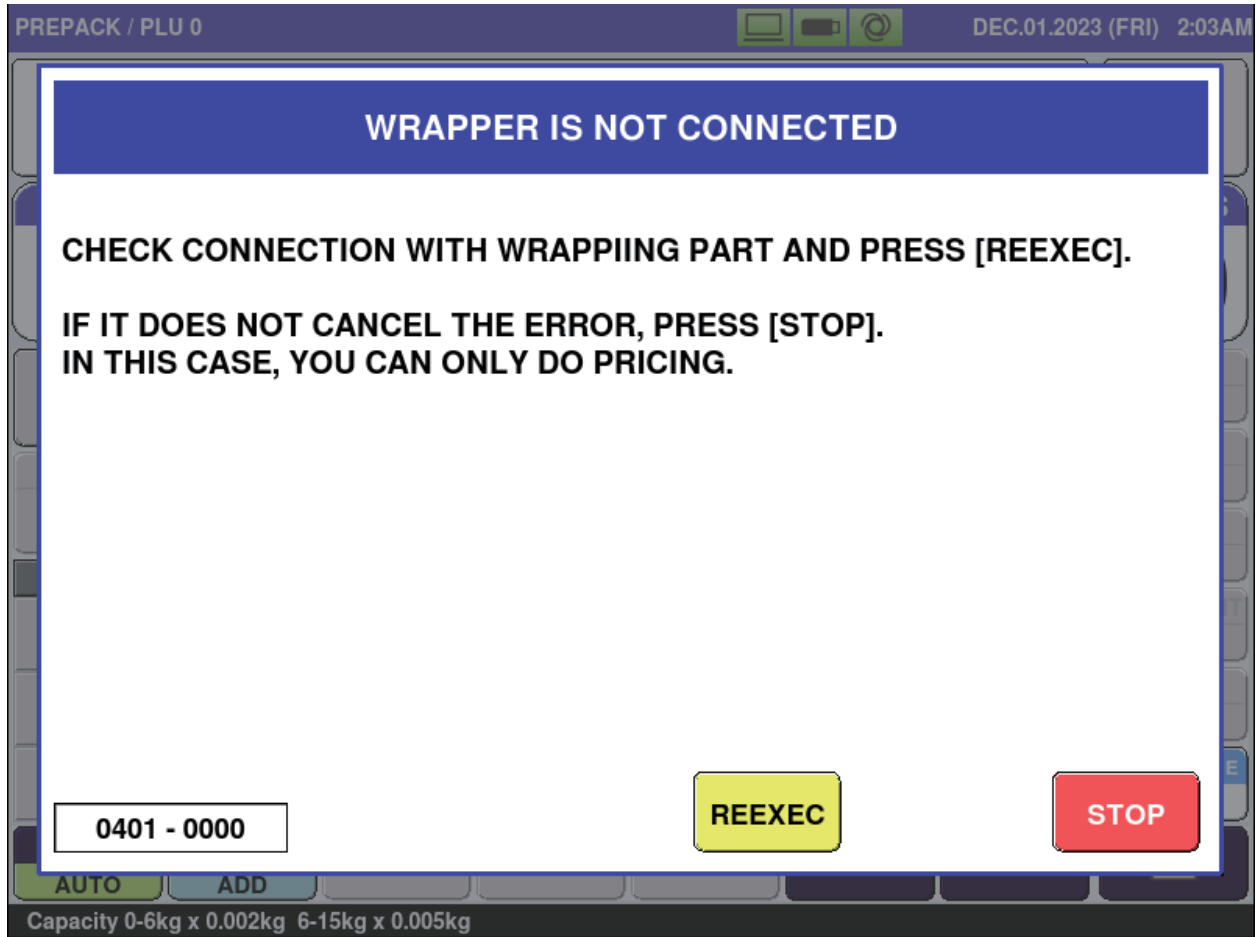

Error content	Wrapper is not connected.
Details	Communication error before power-on processing is completed
Release method	[STOP] button → Releases the error. [REEXEC] button → Checks the connection with the wrapper again.
User's action	Turn the power on and off.
Service person's action	
Related location	
Remarks	After the [STOP] button is pressed, only pricing can be performed.

1.2 NO RESPONSE FROM WRAPPER (402)

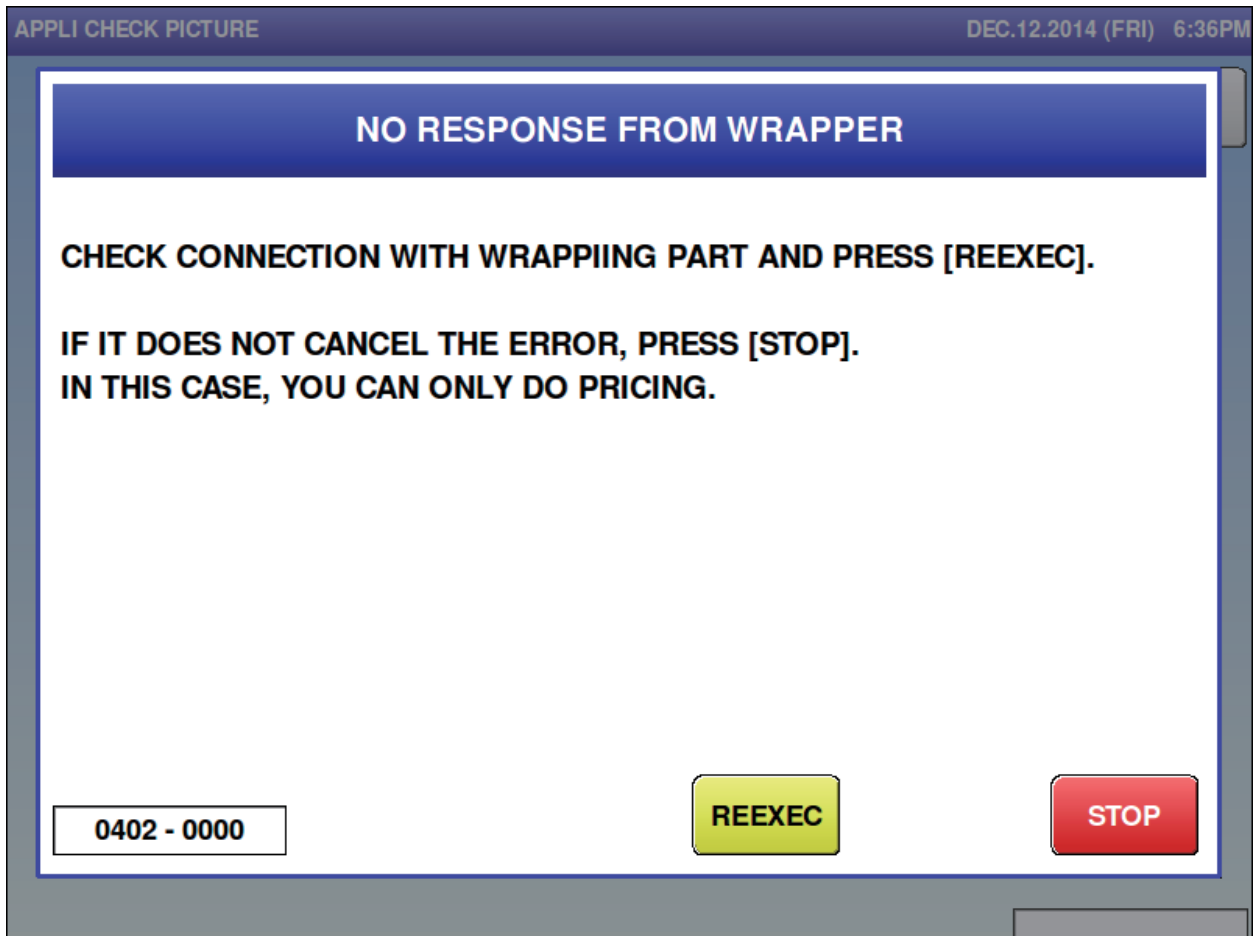

Error content	No response from wrapper
Details	Communication error after power-on processing is completed. The communication phase number is entered in the sub-error.
Release method	[STOP] button → Releases the error. [REEXEC] button → Checks the connection with the wrapper again.
User's action	Turn the power on and off.
Service person's action	
Related location	(1) P-1186 [A1] (2) 24VDC supply to power supply (XJ12) of P-1186 [A1] (3) RS485 communication cable between main board (P-1180) [A10] and P-1186 [A1]
Remarks	After the [STOP] button is pressed, only pricing can be performed.

1.3 PROBLEM CAUSED ON WRAPPER (403)

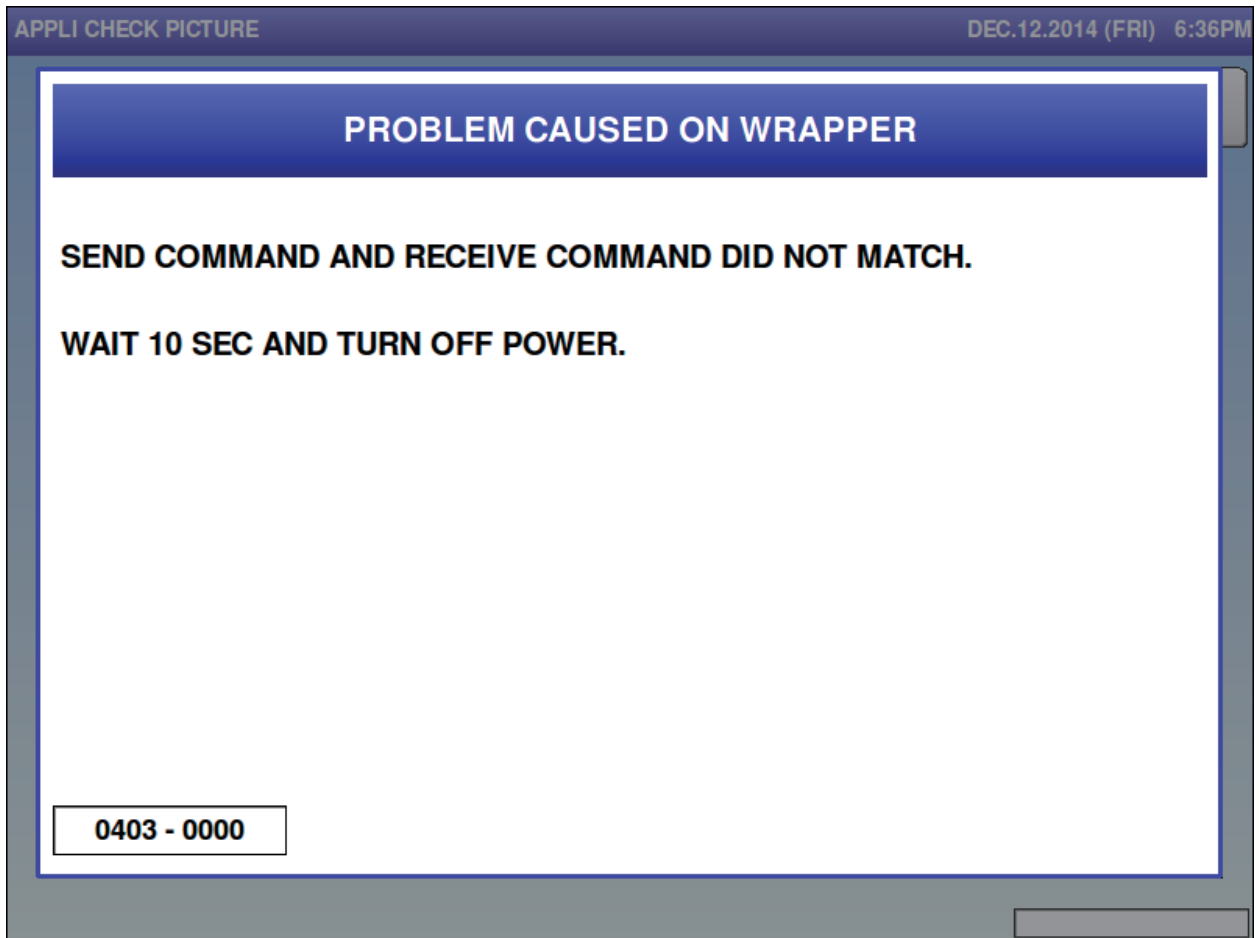

Error content	Communication error with wrapper
Details	Send and receive commands do not match.
Release method	Turn the power back on.
User's action	Turn the power on and off.
Service person's action	
Related location	(1) Main board (P-1180) [A10] (2) P-1186 [A1]
Remarks	

1.4 WRAPPER DETECTED TEMPORARY BLACKOUT (406)

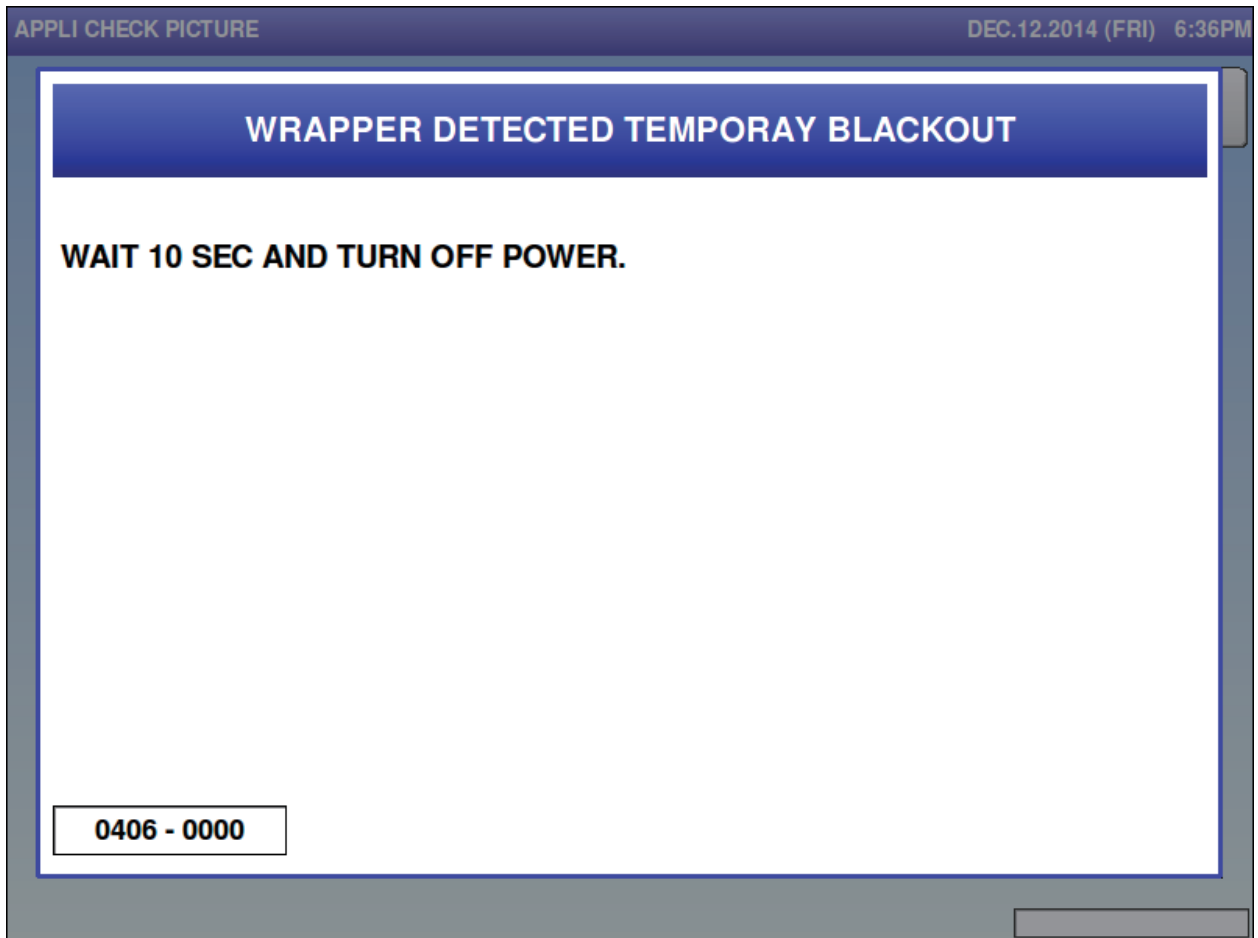

Error content	The CPU in the wrapper control unit has been reset.
Details	The console received power-on notification command (status inquiry) twice from the wrapper.
Release method	Turn the power back on.
User's action	Turn the power on and off.
Service person's action	
Related location	(1) P-1186 [A1] (2) Switching power supply of control unit section [U1]
Remarks	

1.5 TEMPORARY BLACKOUT ON CONSOLE (407)

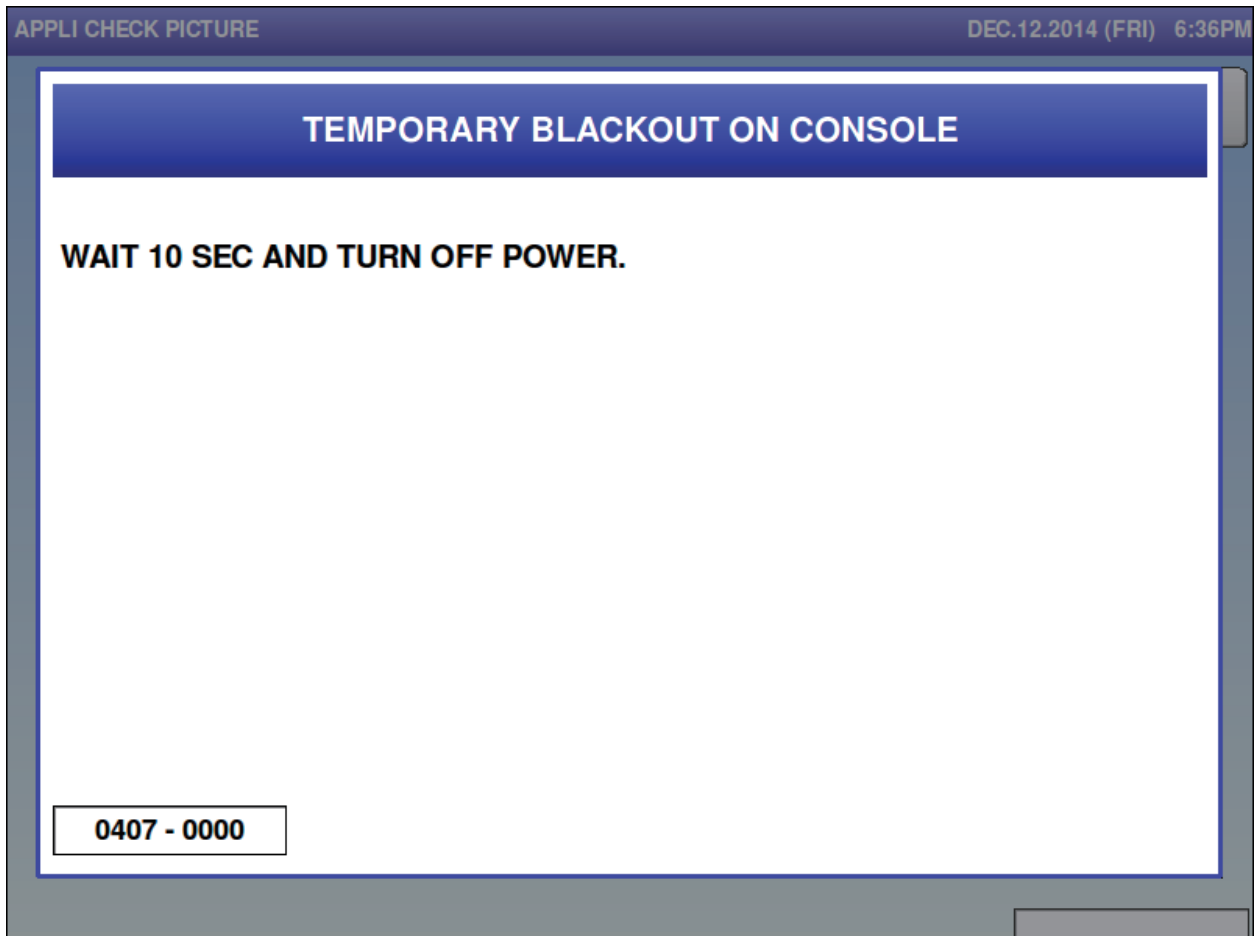

Error content	The CPU in the console has been reset.
Details	Received power-on notification command twice from the console.
Release method	
User's action	Turn the power on and off.
Service person's action	
Related location	(1) Main board (P-1180) [A10] (2) Switching power supply of control unit section [U1]
Remarks	

1.6 LIFT MOTOR IS ABNORMAL (410)

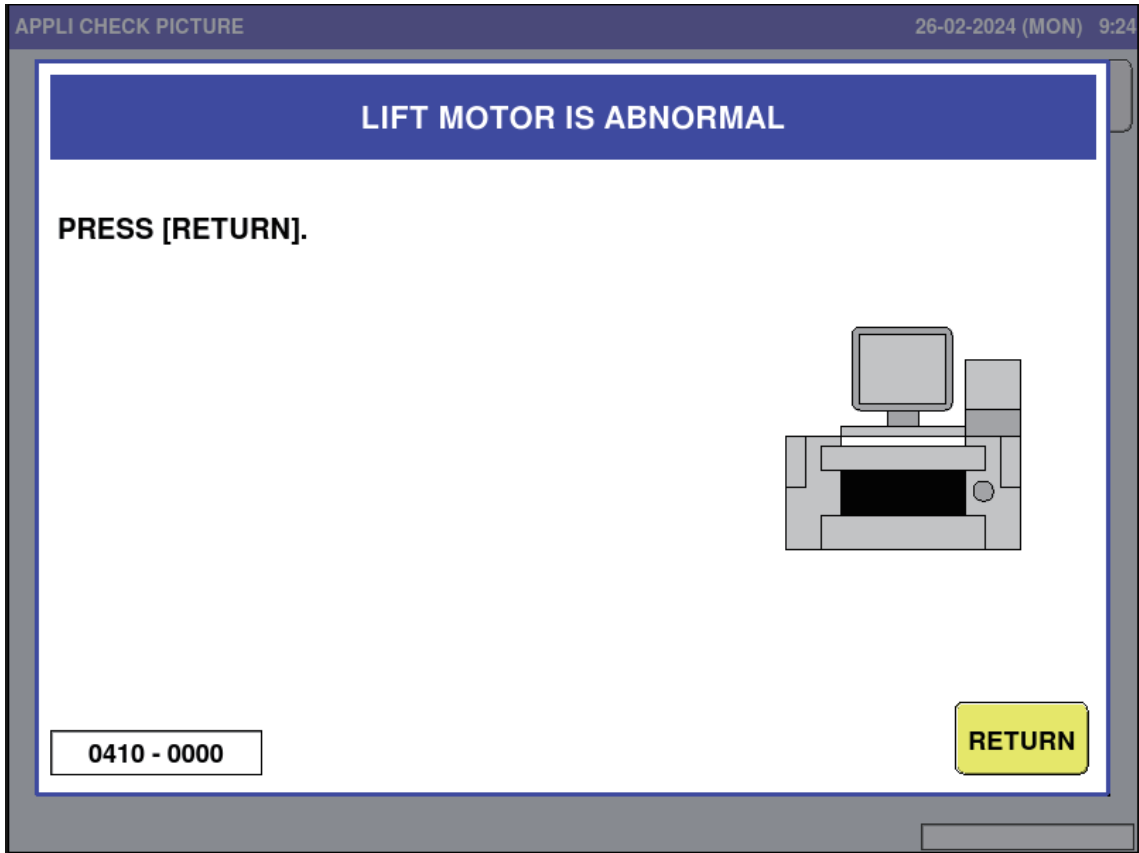

Error content	Lift motor error
Details	<p>The lift motor did not work properly. The meaning of each sub-error is as follows: 0001: Operation protection timer was up but operation was not completed. 0002: Speed pulse signal from DCB motor cannot be detected. 0003: Overload of the DCB motor occurred. 0004: Phase interruption of the DCB motor occurred. 0999: The speed pulse from the DCB motor dropped below 600 rpm. (This occurs when the product is caught between the rear folder and the discharge table)</p>
Release method	Press the [RETURN] button.
User's action	
Service person's action	
Related location	(1) P-1186 [A1] (2) Main cam (lift) motor [M1] (3) Lift origin [B1]
Remarks	

1.7 MOTOR FOR BACK SQUEEZE PLATE IS ABNORMAL (415)

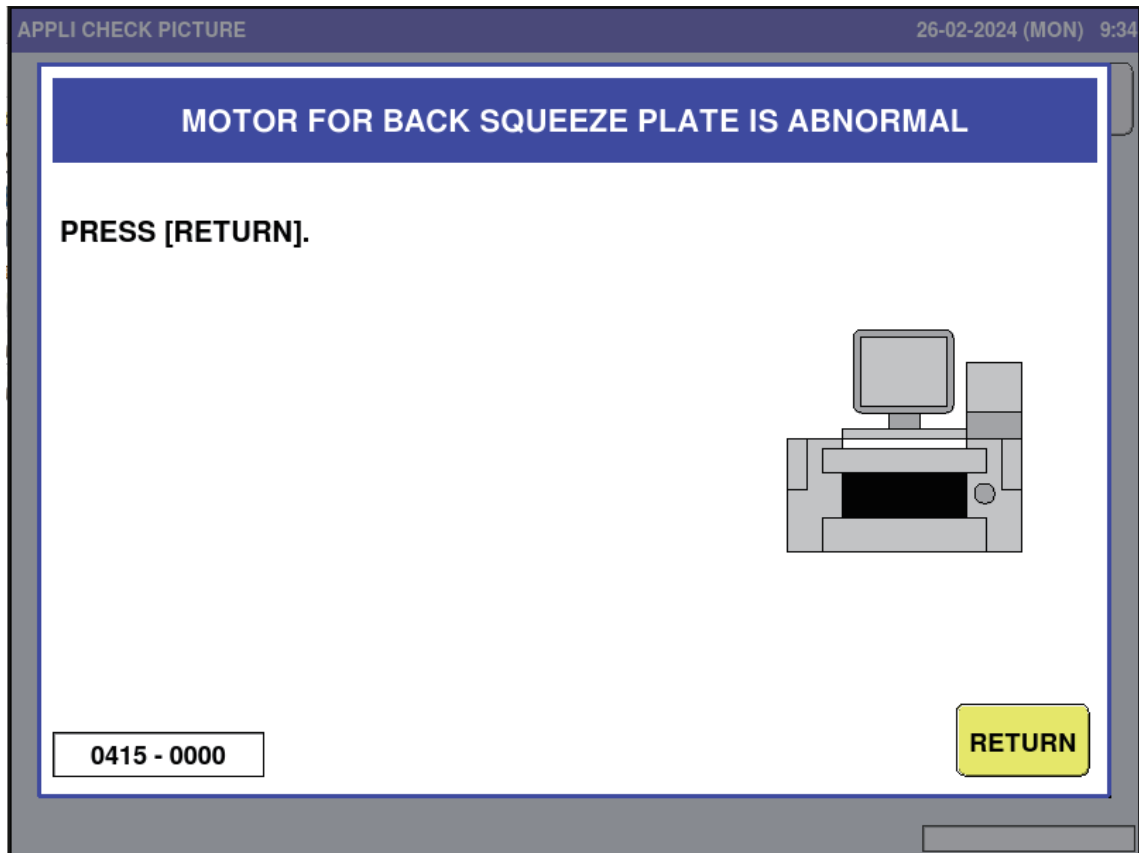

Error content	Back squeezing error
Details	<p>Back squeezing operation could not be completed successfully. The meaning of each sub-error is as follows:</p> <p>0011: During back squeezing operation, the back squeeze plate should have come to the front, but the back squeezing front detection sensor did not detect the back squeeze plate.</p> <p>0012: At the start of the back squeezing operation, the back squeezing front detection sensor detects the back squeezing plate.</p>
Release method	Press the [RETURN] button.
User's action	
Service person's action	
Related location	<p>(1) P-1186 [A1] (2) Main cam motor [M1] (3) Back squeezing limit [B16]</p>
Remarks	

1.8 MOTOR FOR R/L SQUEEZE IS ABNORMAL (416)

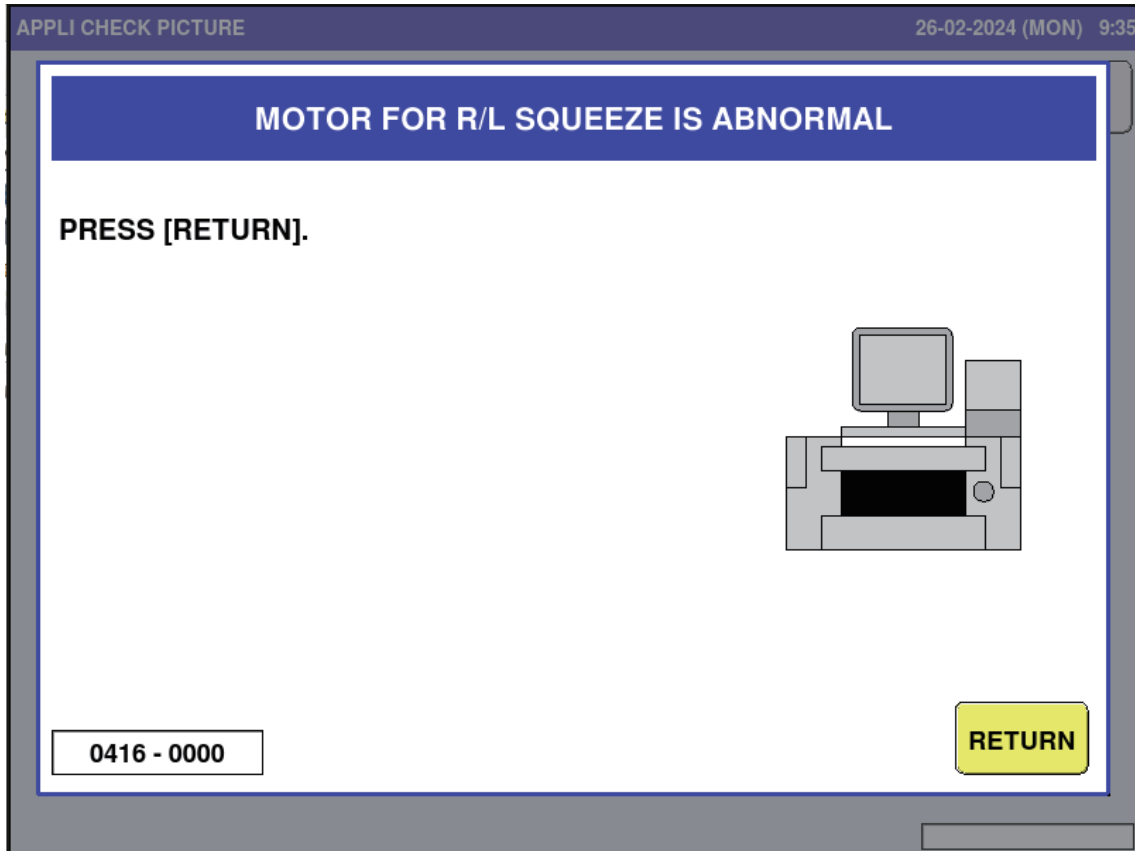

Error content	Left/right squeezing motor error
Details	<p>Left and right squeezing motor operation could not be completed successfully.</p> <p>The meaning of each sub-error is as follows:</p> <p>0001: Operation protection timer was up but operation was not completed.</p> <p>0010: The left and right squeeze plates were not back to their original positions at the start of the left and right squeezing operation.</p> <p>0020: The left and right squeeze plates were not back to their original positions at the start of the main cam motor.</p> <p>0101: The unit was not back to its original position even after the specified time had elapsed, although homing was performed prior to the start of unit operation.</p> <p>0103: The unit was not back to its original position even after the specified time had elapsed in the left/right squeezing return operation of the unit operation.</p>
Release method	Press the [RETURN] button.
User's action	
Service person's action	
Related location	<p>(1) P-1186 [A1]</p> <p>(2) P-1006 [A2]</p> <p>(3) Drive motor for left/right squeezing [M3]</p> <p>(4) Left/right squeeze plate origin [B2]</p>
Remarks	

1.9 FEEDER MOTOR IS ABNORMAL (418)

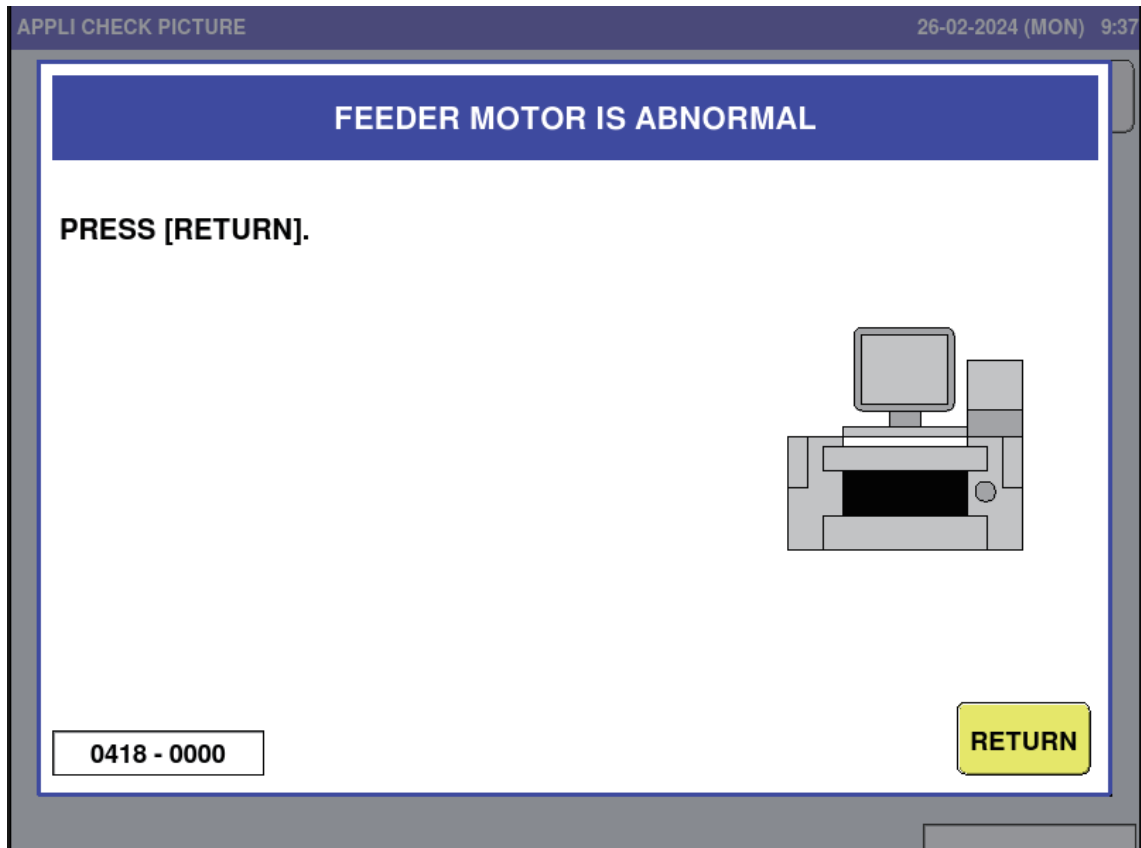

Error content	Feeder motor error
Details	Feeder motor operation could not be completed successfully. The meaning of each sub-error is as follows: 0001: Operation protection timer was up but operation was not completed.
Release method	Press the [RETURN] button.
User's action	
Service person's action	
Related location	(1) P-1186 [A1] (2) P-1006 [A2] (3) Feeder drive motor [M2]
Remarks	

1.10 FILM HEATER HAS PROBLEM (426)

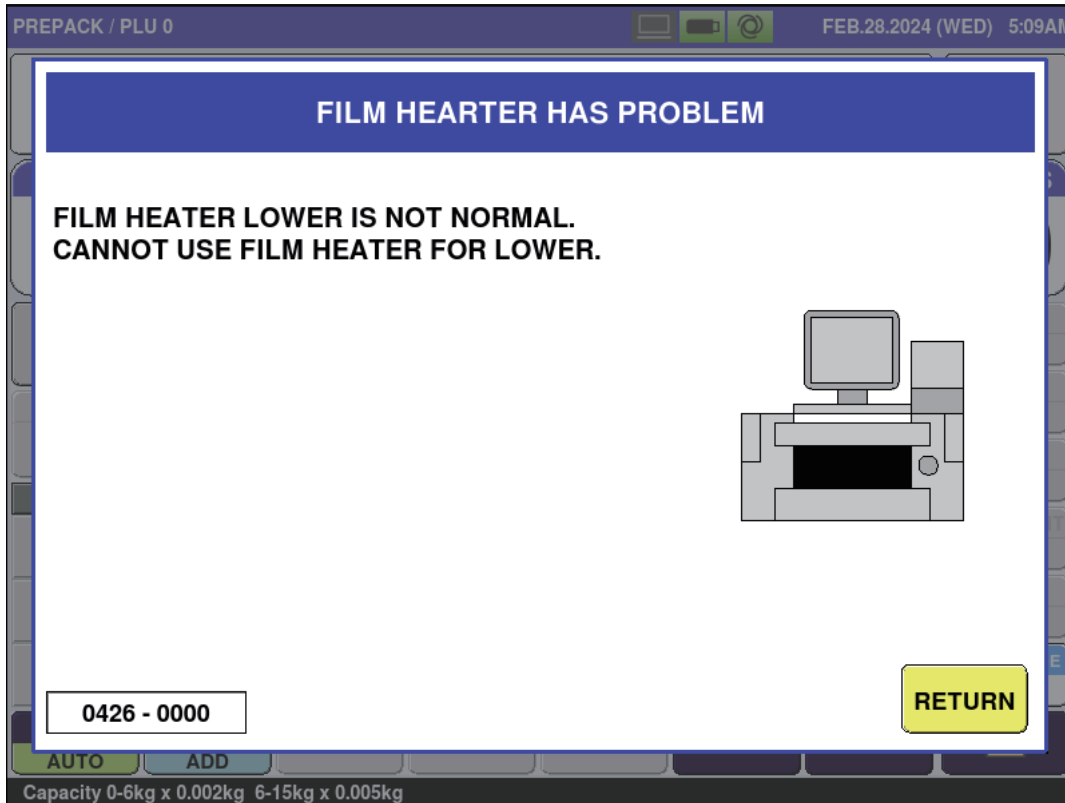

Error content	Film heater error
Details	An error occurred in the film heater and the heater became unusable. <Sub-error> 0001: Thermistor disconnection 0100: There is an operational abnormality in the fan of the fan heater (alarm detected). (Fan is not rotating or fan cable is disconnected) 0101: The fan of the fan heater is rotating by itself (when the power is ON).
Release method	Press the [RETURN] button.
User's action	
Service person's action	
Related location	(1) P-1186 [A1] (2) Film heater fan [M4]
Remarks	

1.11 MOTOR VOLTAGE IS ABNORMAL (435)

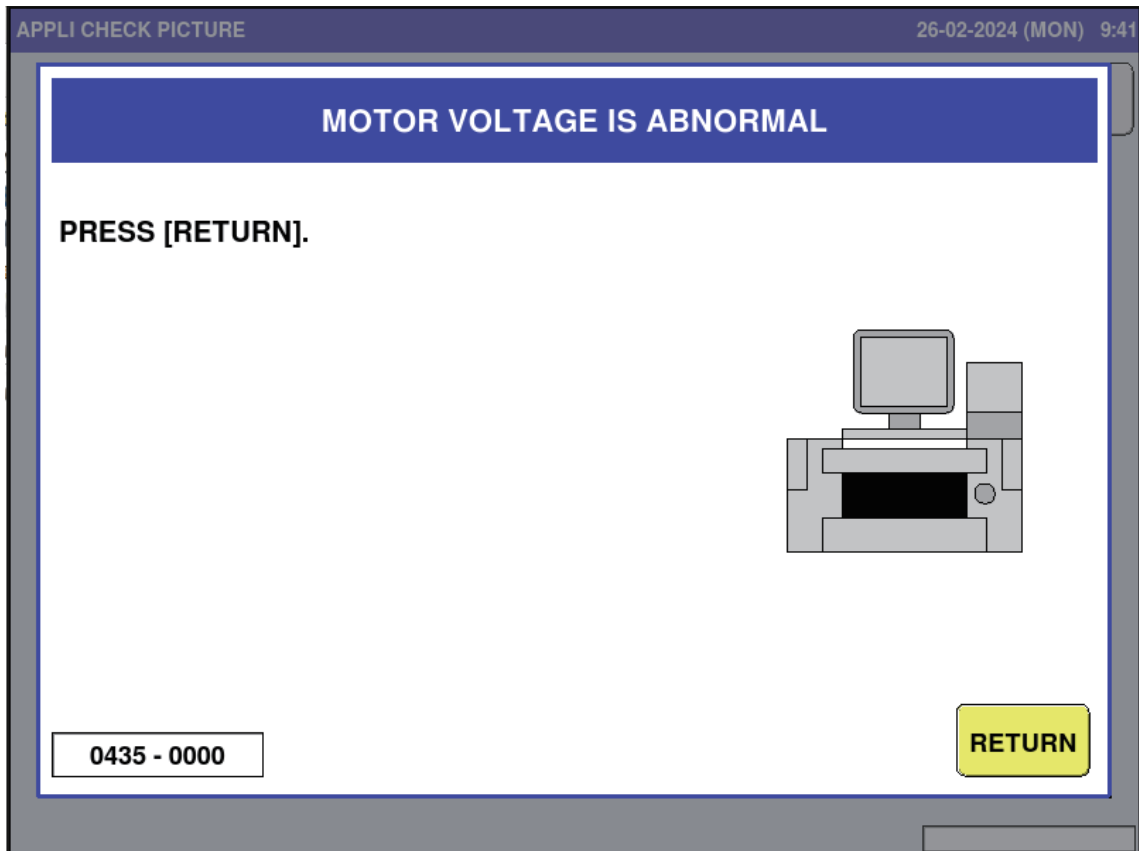

Error content	Supply voltage to the wrapper board is abnormal.
Details	Occurs when a voltage error is detected on the P-1186 board. 0001: Undervoltage detected at P-1186 [A1]. 0002: Overvoltage detected at P-1186 [A1].
Release method	Press the [RETURN] button. (This is not an error that can be recovered by pressing the [RETURN] button)
User's action	
Service person's action	
Related location	(1) Check the input power supply 200 to 240VAC (2) P-1186 [A1]
Remarks	

1.12 EMERGENCY STOP HAS BEEN PUSHED (440)

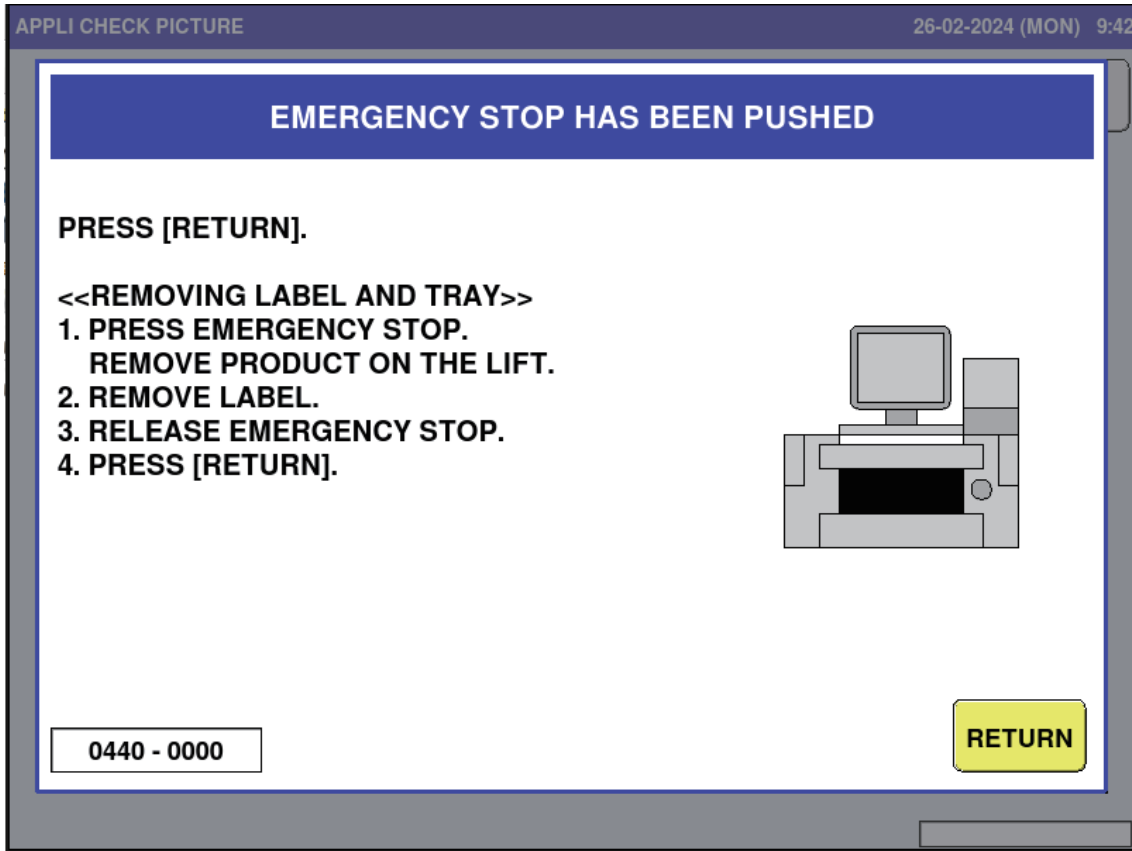

Error content	The emergency stop button was pressed during operation.
Details	Occurs when the emergency stop button is pressed while the wrapper is in operation.
Release method	Release the emergency stop button and press the [RETURN] button.
User's action	
Service person's action	
Related location	
Remarks	

1.13 RIGHT SIDE COVER IS OPEN (441)

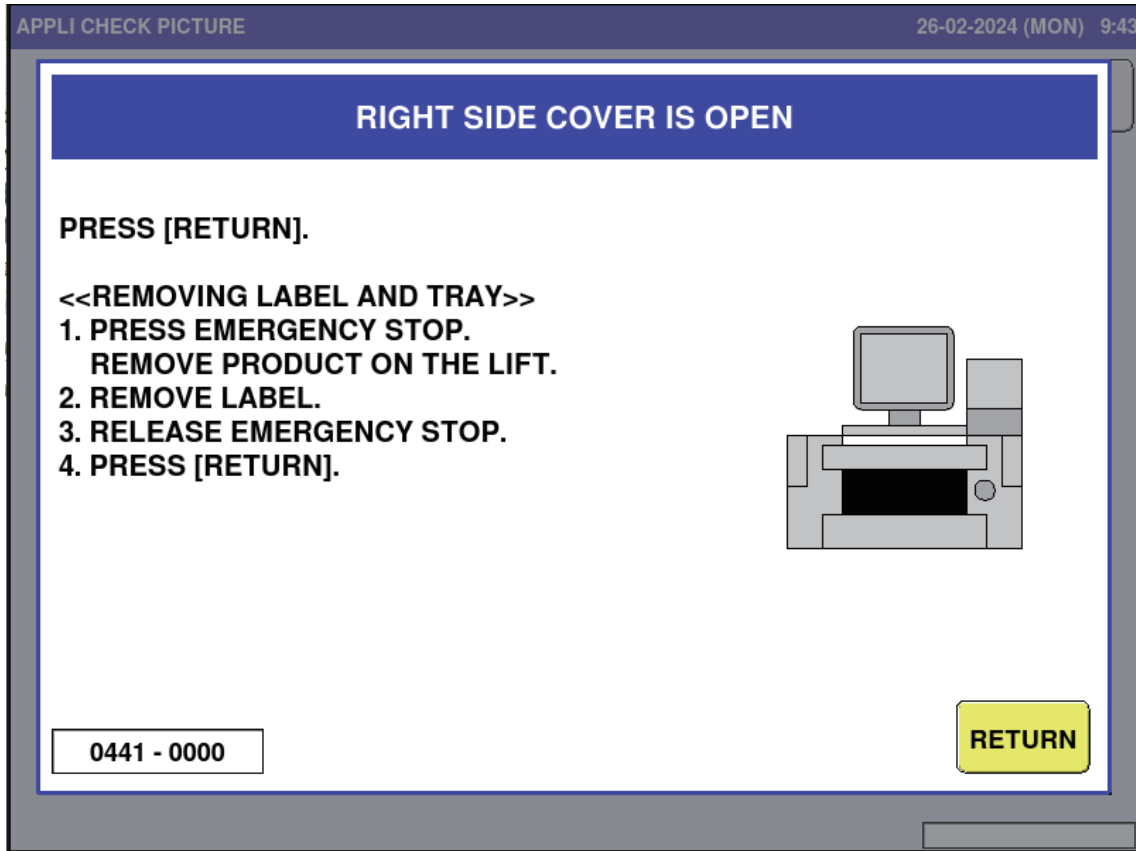

Error content	The right-side cover was opened during operation.
Details	Occurs when the right-side cover is opened while the wrapper is in operation.
Release method	Close the right-side cover and press the [RETURN] button.
User's action	
Service person's action	
Related location	
Remarks	

1.14 LEFT SIDE COVER IS OPEN (442)

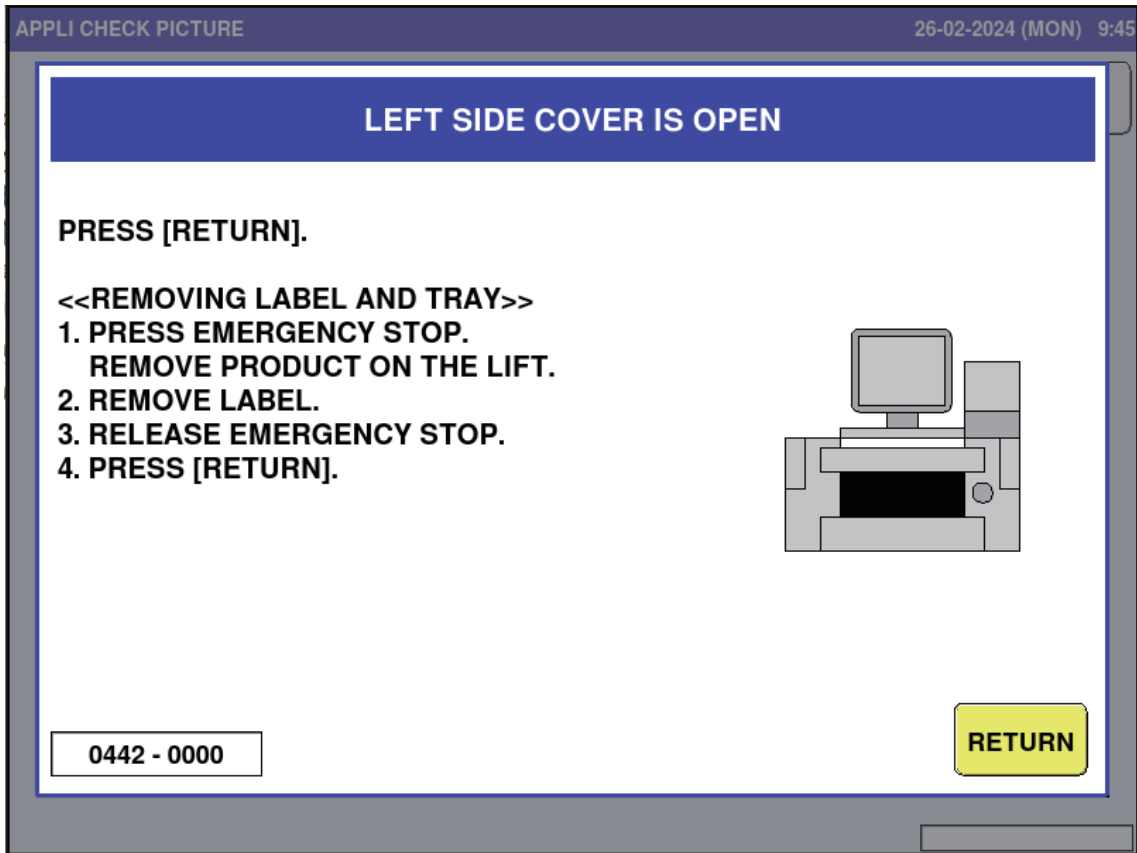

Error content	The left-side cover was opened during operation.
Details	Occurs when the left-side cover is opened while the wrapper is in operation.
Release method	Close the left-side cover and press the [RETURN] button.
User's action	
Service person's action	
Related location	
Remarks	

1.15 DON'T PUT YOUR HANDS INTO THE MACHINE (448)

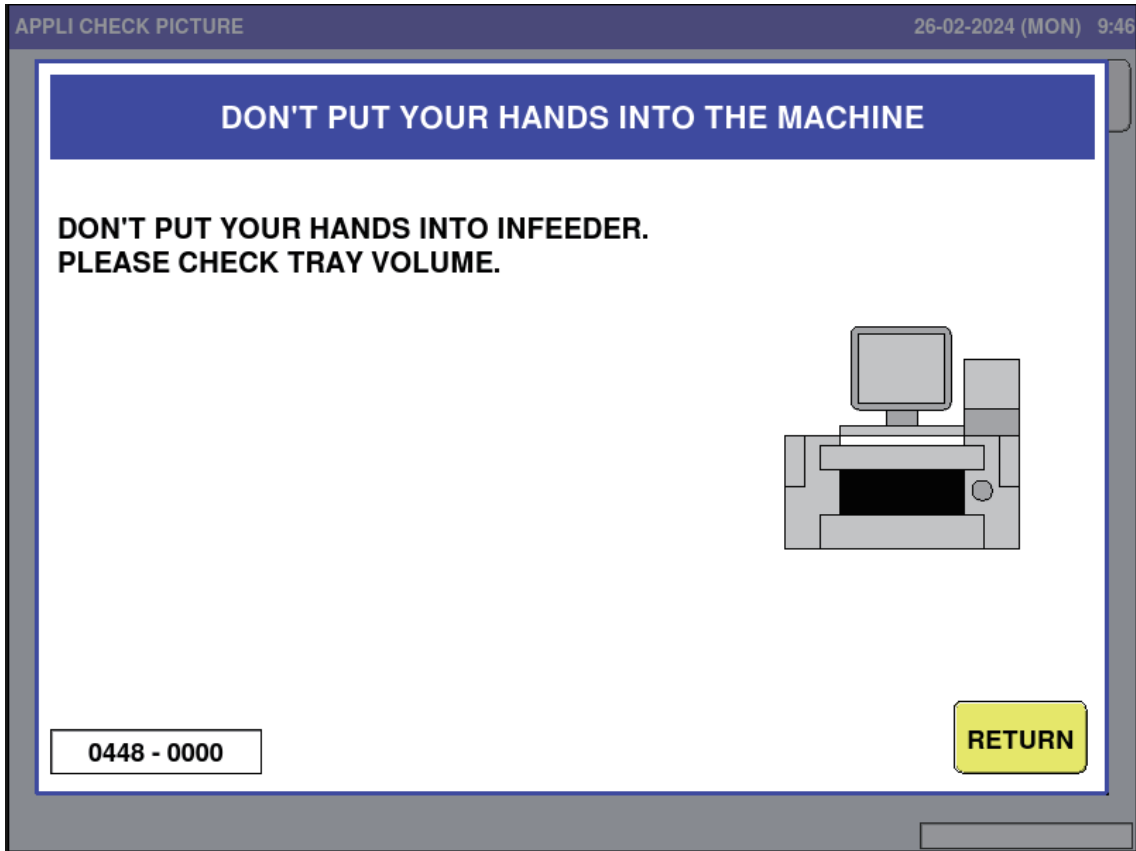

Error content	The infeeder safety sensor was blocked from light during operation.
Details	Occurs when the infeeder safety sensor is blocked from light while the wrapper is in operation and an emergency stop occurs (the machine determines that a hand has been placed in the infeeder). 0000: The safety sensor was blocked from light during the wrapper operation. 0100: During the precheck before operation, the light was still being emitted even though it was turned off.
Release method	Make sure there are no commodities or foreign objects and press the [RETURN] button.
User's action	
Service person's action	
Related location	(1) P-1186 [A1] (2) Infeeder safety sensor (light emitting) [B3], Infeeder safety sensor (light receiving) [B6]
Remarks	Check the filling height setting of the product. Note: If the product height is set to "HIGH", the infeeder safety sensor will be disabled and no error will occur while the product is being conveyed on the lift. The hand-insertion sensor function is enabled when product weighing is stable, regardless of the height setting.

1.16 DON'T PUT YOUR HANDS INTO THE MACHINE (449)

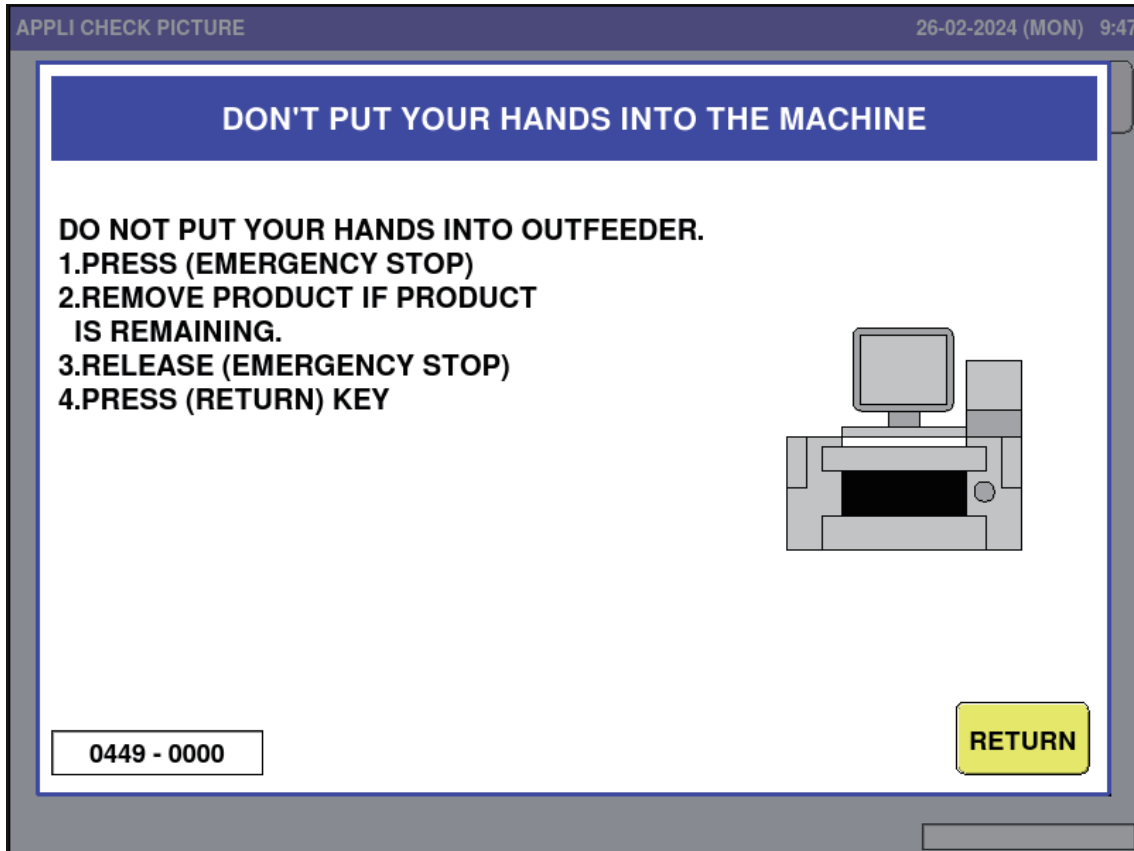

Error content	The outfeeder safety sensor was blocked from light during operation.
Details	Occurs when the outfeeder safety sensor is blocked from light while the wrapper is in operation and an emergency stop occurs (the machine determines that a hand has been placed in the outfeeder). 0000: The safety sensor was blocked from light during the wrapper operation. 0100: During the precheck before operation, the light was still being emitted even though it was turned off.
Release method	Make sure there are no commodities or foreign objects and press the [RETURN] button.
User's action	
Service person's action	
Related location	(1) P-1186 [A1] (2) Outfeeder safety sensor (light emitting) [B4], Outfeeder safety sensor (light receiving) [B7]
Remarks	

1.17 MACHINE IS RETURNING TO STAND BY POSITION (459 to 9999)

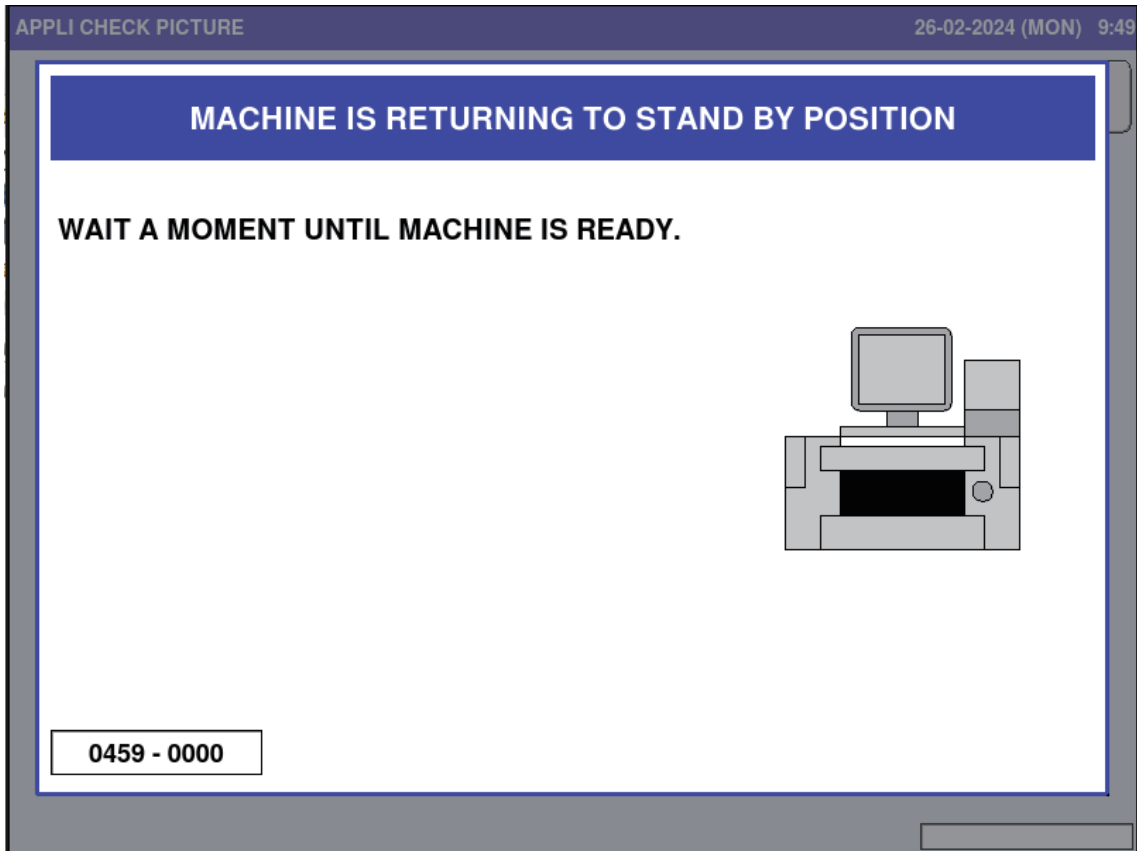

Error content	The return operation is in progress.
Details	Indicates that the wrapper is in the process of returning. Switch to the Initial screen when the machine is ready.
Release method	
User's action	
Service person's action	
Related location	
Remarks	

1.18 FILM OVER ERROR (461)

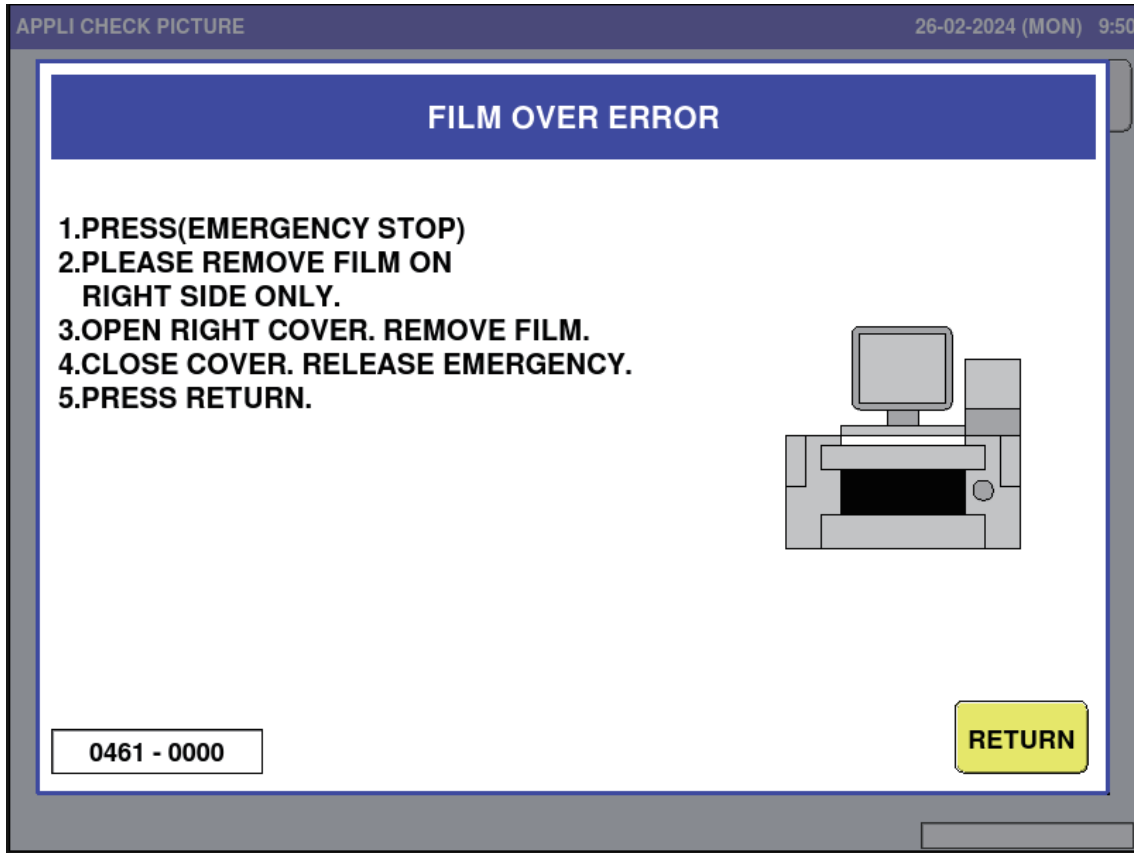

Error content	Film over error
Details	Occurs when the detection sensor detects a film during film transport. The meaning of each sub-error is as follows: 0003: Film detected by detection sensor on front side 0004: Film detected by detection sensor on rear side
Release method	Press the [RETURN] button.
User's action	
Service person's action	
Related location	(1) P-1186 [A1] (2) Film over detection sensor (front) [B14] (3) Film over detection sensor (rear) [B15]
Remarks	Remove the film before operation.

1.19 THERE IS PROBLEM ON WRAPPING CONTROLLER (470)

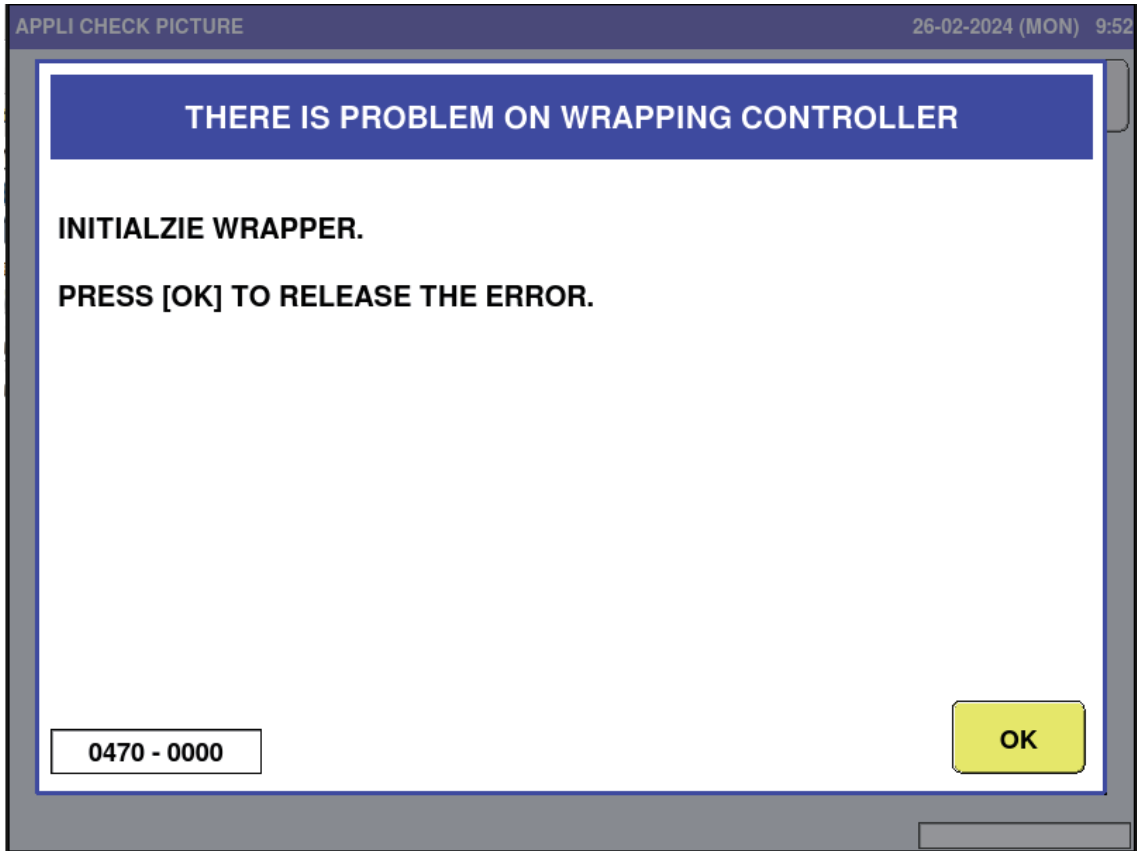

Error content	The wrapper is not initialized.
Details	E2ROM of the wrapper is not initialized. (Checksum of E2ROM storage data is NG (No Good))
Release method	Press the [OK] button.
User's action	
Service person's action	
Related location	
Remarks	After releasing the error, the wrapper needs to be initialized on the wrapper setting screen in the test mode.

1.20 THERE IS PROBLEM ON WRAPPING CONTROLLER (471)

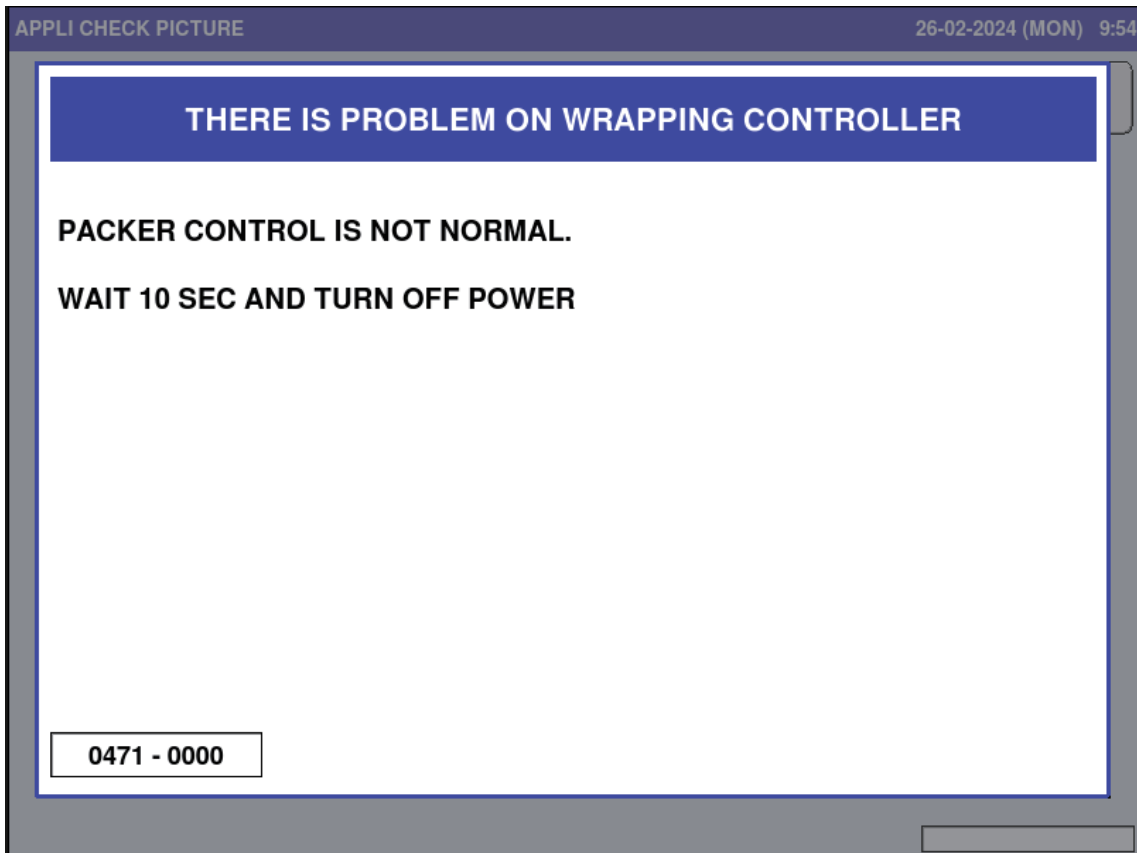

Error content	The wrapper's control board is faulty.
Details	An abnormality occurred in the wrapper control board. The meaning of each sub-error is as follows: 0003: E2ROM write error 0088: General-purpose communication IC failure 0999: An internal reset occurred due to rampage or an unexpected interrupt to the CPU.
Release method	Power on again.
User's action	
Service person's action	
Related location	P-1186 [A1]
Remarks	

1.21 THERE IS PROBLEM ON SEAL HEATER (473)

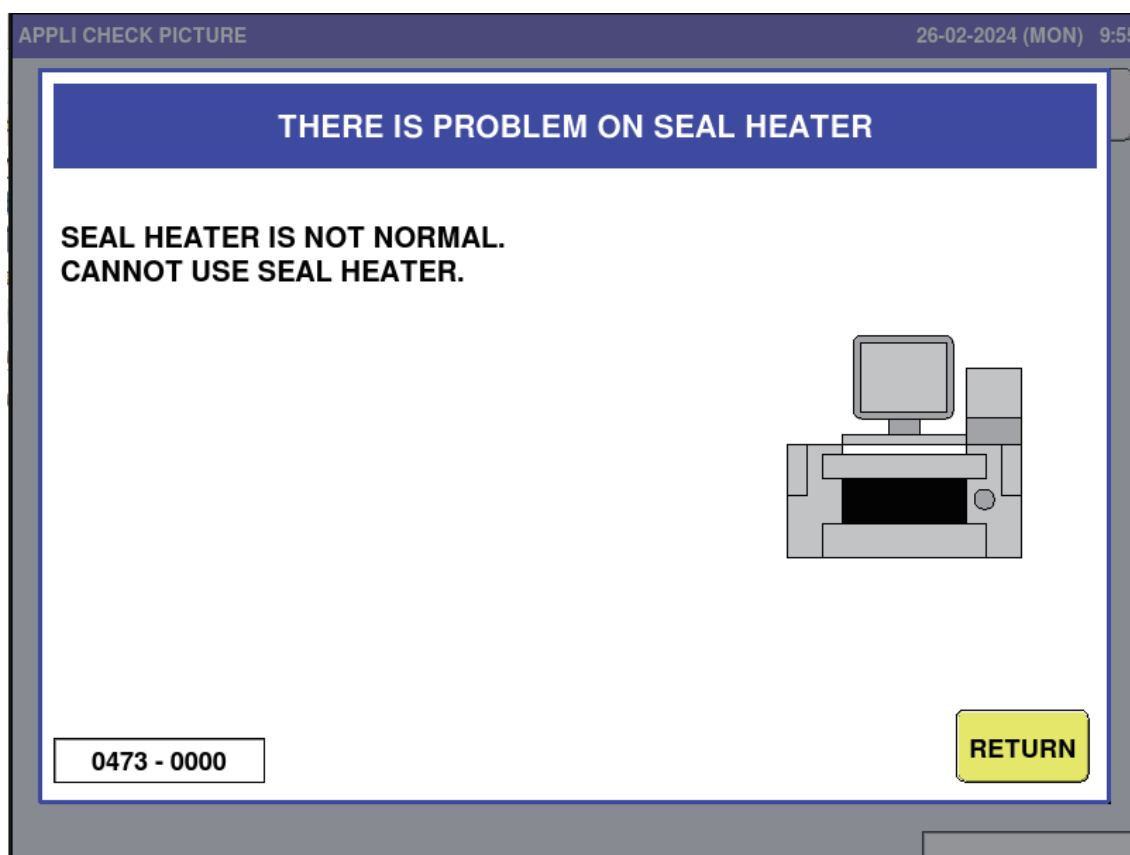

Error content	The seal heater in the outfeeder is abnormal.
Details	An abnormality occurred in the thermistor that monitors the temperature of the seal heater. <Sub-error number> 0000: Heater temperature does not rise even though heating is in progress. 0001: Abnormal thermistor (disconnected or short-circuited)
Release method	[RETURN] button
User's action	
Service person's action	
Related location	(1) P-1186 [A1] (2) Outfeeder seal heater [E2] (3) Fuse for outfeeder seal heater [F5, F6] (4) Thermistor for outfeeder seal heater (front) [R1] (5) SSR for outfeeder seal heater (front) [K2]
Remarks	When this error occurs, the seal heater is forcibly turned off.

1.22 FAILED TO FEED FILM (482)

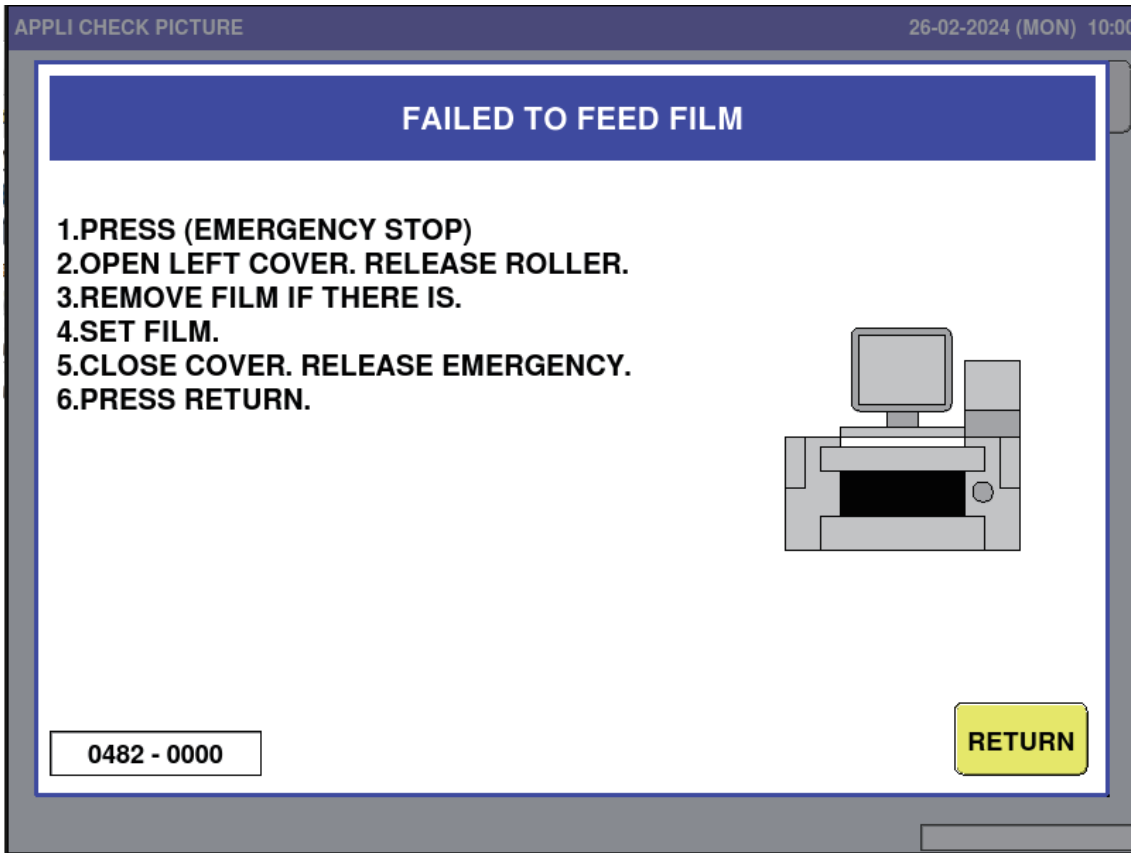

Error content	Failed to feed film.
Details	<p>(1) The film insertion arm does not return to its origin position at the time of cutter operation. The insertion arm origin sensor is blocked from light at the time of cutter operation. (Sub-error number 0, 9, 10, 11, or 12 occurs)</p> <p>(2) Film is not set, or film is not supplied because the film is rolled around the film roller. →Any sub-error number from 100 to 102 occurs.</p> <p>(3) Film cannot be detected correctly due to a failure of the film detection sensor. →Any of sub-error number from 100 to 102 occurs.</p> <p><Sub-error number> 0000, 0011: The film insertion arm is not back to its origin position at the time of cutter operation for normal wrapping or film feeding. 0009, 0012: The film insertion arm is not back to its origin position at the time of cutter operation for return and removal. 0010: The film insertion arm is not back to its origin position at the time of cutter operation for unit operation. 0100: Both the front and rear film detection sensors did not detect the film during the period from the start of the film feed operation to the</p>

	<p>detection timeout time.</p> <p>0101: The front film detection sensors did not detect the film during the period from the start of the film feed operation to the detection timeout time.</p> <p>0102: The rear film detection sensors did not detect the film during the period from the start of the film feed operation to the detection timeout time.</p>
Release method	Press the [RETURN] button.
User's action	
Service person's action	
Related location	<p>(1) P-1186 [A1]</p> <p>(2) Film detection sensor (front) [B9], Film detection (rear) [B10]</p> <p>(3) Film transport origin [B11]</p>
Remarks	<p>Note 1: If the sub error number is any number from 100 to 102, the error can only be released by opening and closing the left side cover.</p> <p>Note 2: This error will not occur if the film detection sensor is set to "NO".</p>

1.23 AUXILIARY FOR MAGNETIC CONTACT IS ABNORMAL (485)

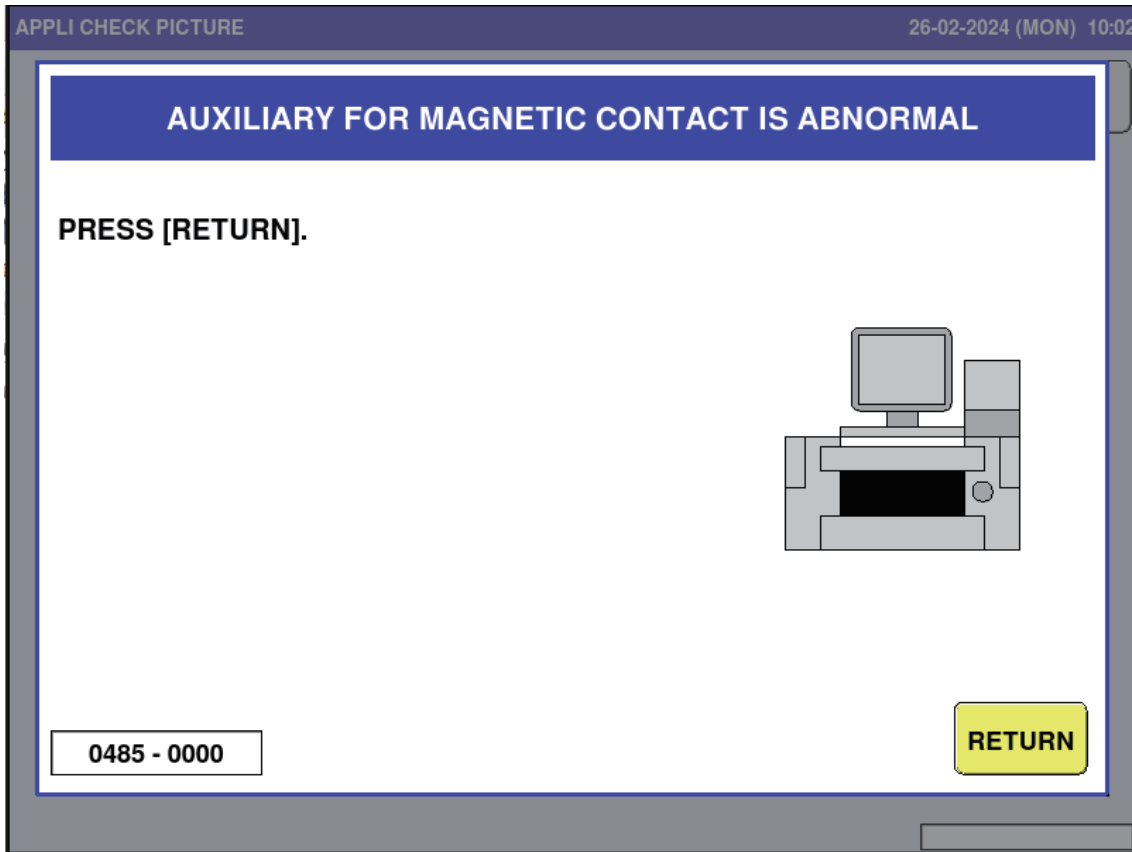

Error content	Auxiliary contact of the electromagnetic contactor is abnormal.
Details	<p>When the wrapper is on stand-by, the discrepancy between the auxiliary contact state of the electromagnetic contactor that switches the power line and the emergency stop and each cover open/close state (e.g., the cover is open, but power does not turn off) lasted for more than 5 seconds. Or the conflicting state occurred during operation.</p> <p><Sub-error number></p> <p>0000: The electromagnetic contactor is OFF even though there is no open cover.</p> <p>0128: The electromagnetic contactor is ON even though the emergency stop button is pressed.</p> <p>0064: The electromagnetic contactor is ON even though the right-side cover is open.</p> <p>0032: The electromagnetic contactor is ON even though the left-side cover is open.</p>
Release method	Press the [RETURN] button.
User's action	
Service person's action	
Related location	<p>485-0000:</p> <p>(1) P-1186 [A1]</p> <p>(2) Electromagnetic contactor [K1] and wiring to electromagnetic contactor</p> <p>Other than 485-0000:</p> <p>(1) Wiring to the switch detailed above</p>
Remarks	When the cover is closed halfway, this error is likely to occur, although it is not a malfunction.

1.24 FILM REMOVAL IS COMPLETED (492)

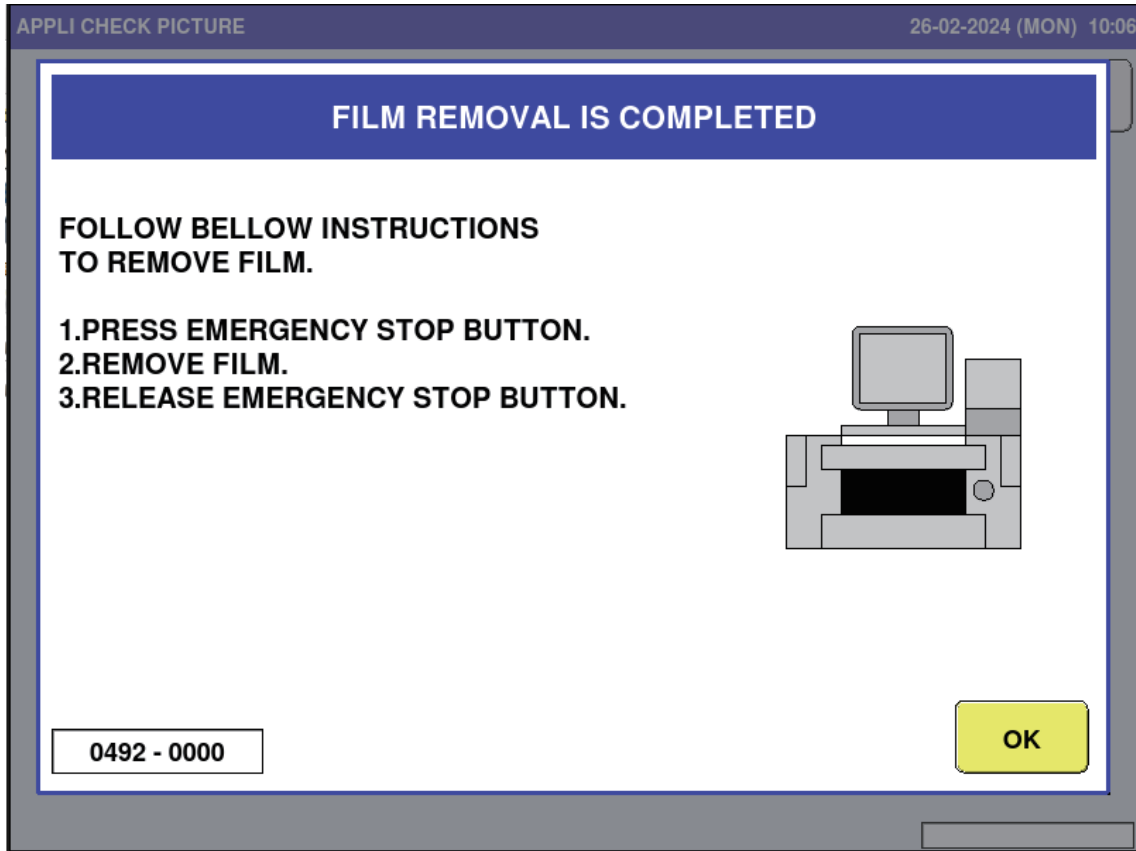

Error content	Film removal operation completed
Details	The film removal operation is completed.
Release method	Remove the film by following the steps below: 1. Press the emergency stop button. 2. Remove the film. 3. Release the emergency stop button.
User's action	
Service person's action	
Related location	
Remarks	

1.25 REMOVING FILM (493)

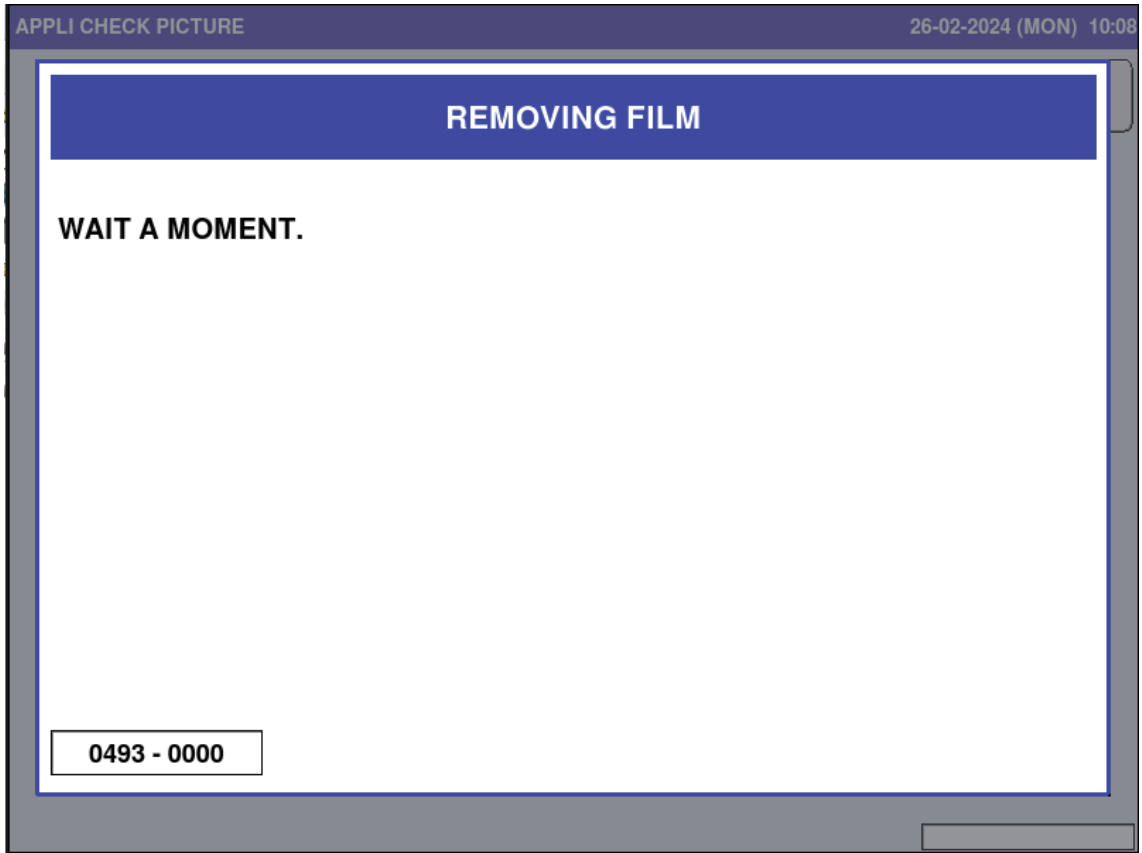

Error content	Film is being removed
Details	
Release method	The error is automatically released after the film removal operation is completed.
User's action	
Service person's action	
Related location	
Remarks	

1.26 PROBLEM ON WRAPPING PART (494)

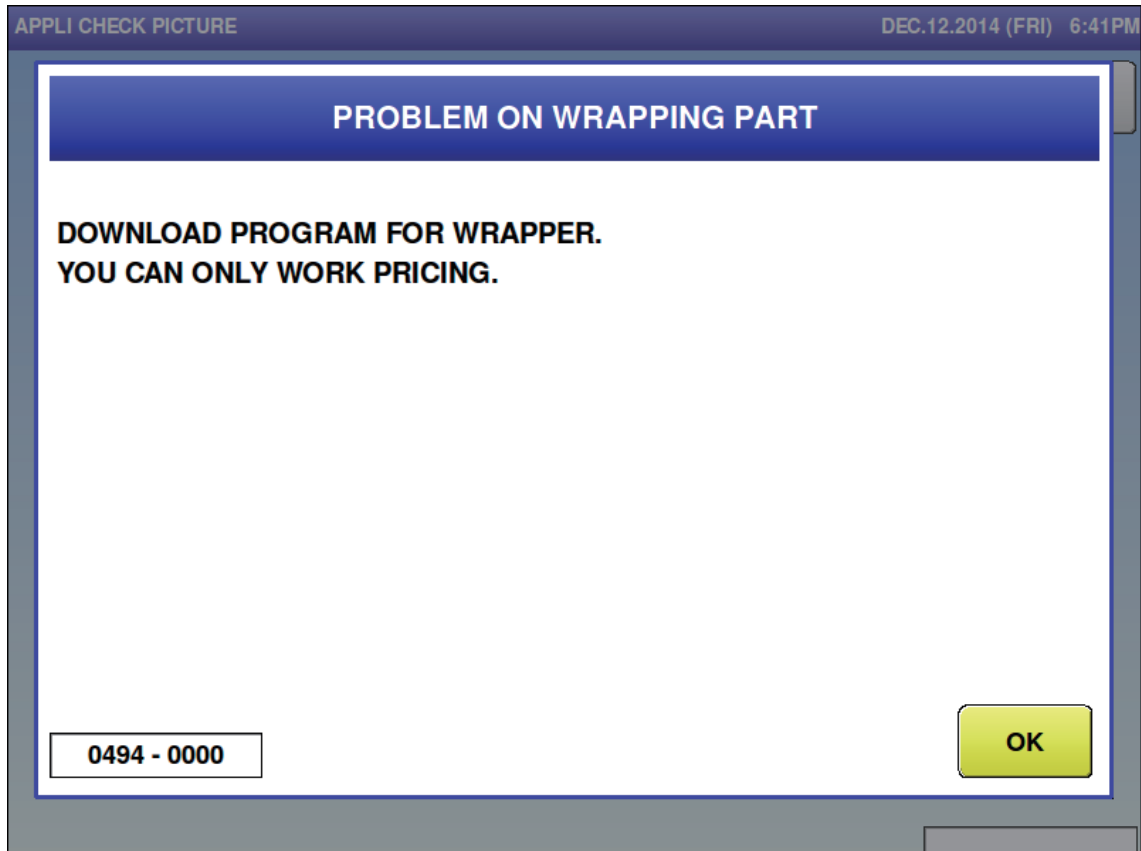

Error content	No wrapper application program
Details	<p>The wrapper software has not been downloaded, or the wrapper software cannot be recognized (downloaded incorrectly).</p> <p>Note: Only pricing work is possible immediately after the error is released.</p> <p><Sub-error number></p> <p>0000: Checksum of application program (wrapper app 1) does not match.</p> <p>0001: Migration to application failed.</p> <p>0012: The model setting is L type, but the hardware is LL type.</p> <p>0014: The model setting is LL type, but the hardware is L type.</p>
Release method	Press the [OK] button.
User's action	
Service person's action	
Related location	<p>(1) Machine setting</p> <p>(2) Check the relay connector (No. ring X130) on XJ8-3,4PIN of P-1186 [A1]</p> <p>For L type, remove the relay connector.</p> <p>For LL type, connect the relay connector.</p>
Remarks	Wrapper application must be downloaded.

Error display: 494-0012

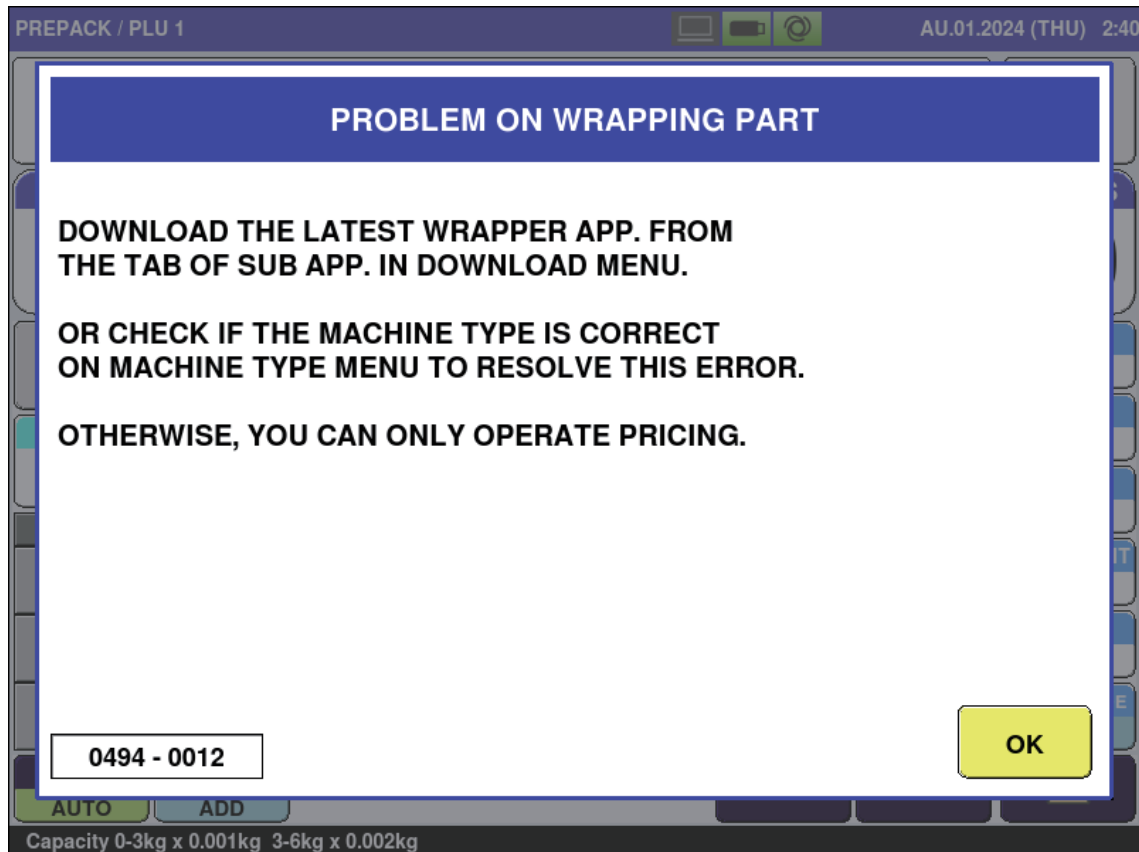

Error display: 494-0014

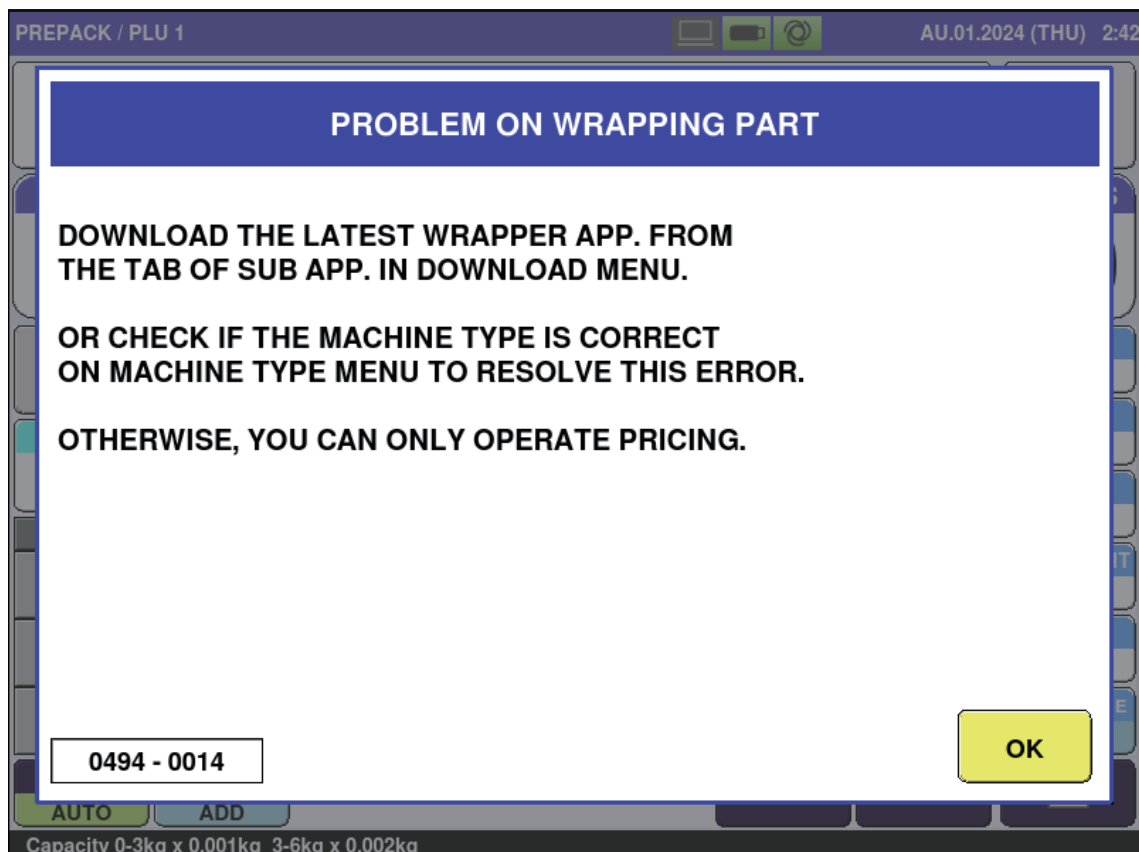

1.27 SUM VALUE FOR RECEIVING IS ABNORMAL (495)

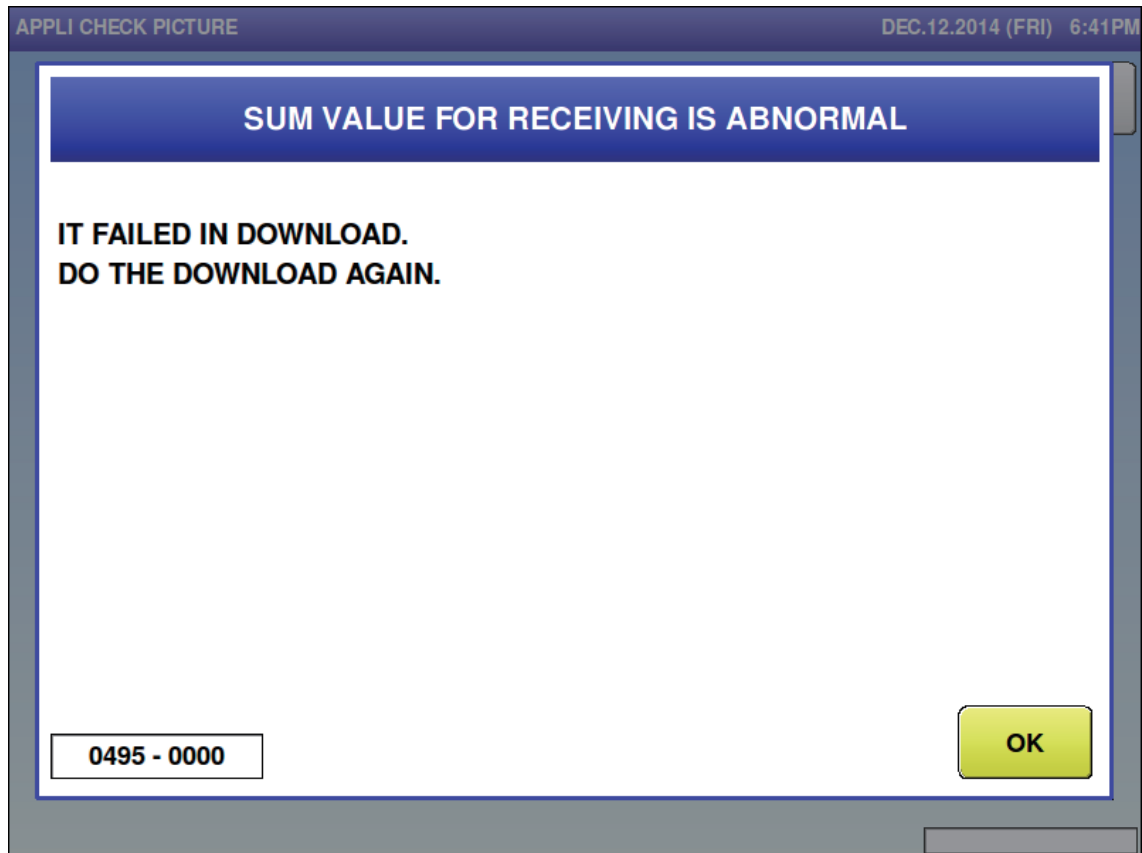

Error content	Incorrect sum value of received data when downloading wrapper app
Details	The sum value of the program data received by the wrapper and the sum value attached to the protocol do not match.
Release method	Press the [OK] button.
User's action	
Service person's action	
Related location	
Remarks	Download needs to be redone.

1.28 WRITING FOR FLASH ROM IS BUSY (496)

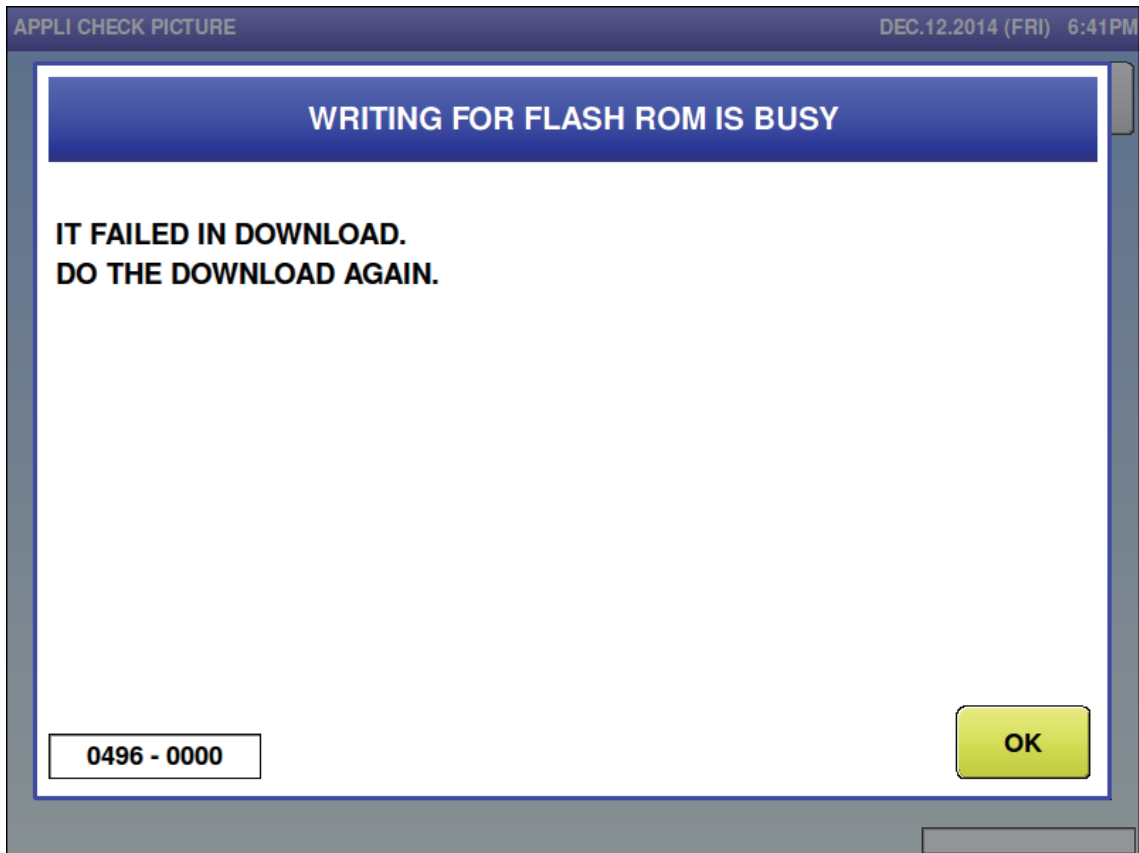

Error content	Flash ROM write state is too long.
Details	The flash ROM write state does not change after a certain period of time when the wrapper application program is downloaded.
Release method	Press the [OK] button.
User's action	
Service person's action	
Related location	
Remarks	Download needs to be redone.

1.29 FAILED IN WRITING IN FLASH ROM (497)

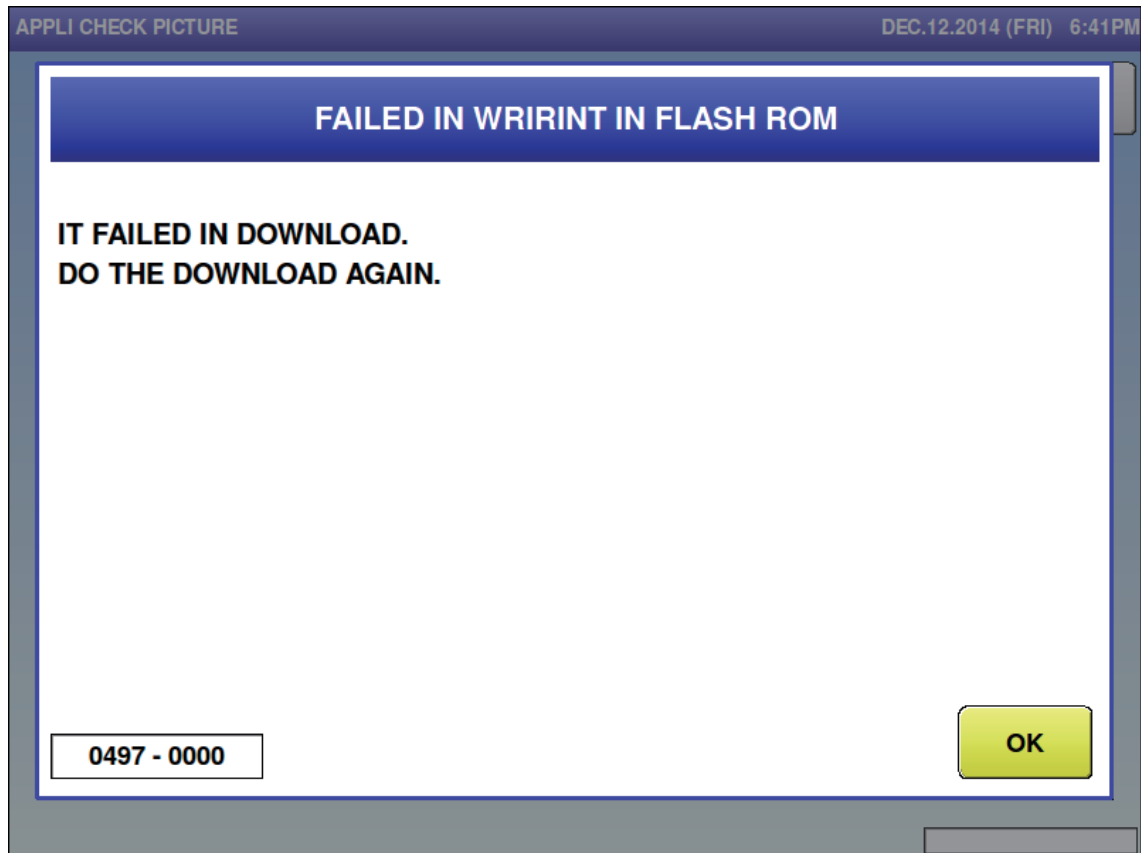

Error content	Wrapper program download failed to write flash ROM.
Details	The wrapper failed to write the received program data to flash ROM. The meaning of each sub-error is as follows: 0001: Failed to erase flash ROM. 0002: Failed to write the application program to flash ROM. 0003: Failed to write the application program sum value to flash ROM. 0004: The protocol sequence up to flash ROM writing was deviated. 0005: Received a command regarding download even though not in boot mode (application program running).
Release method	Press the [OK] button.
User's action	
Service person's action	
Related location	Make sure that 2, 3, and 4 of DIP switch SW1 on P-1186 [A1] are all set to OFF.
Remarks	Download needs to be redone.

1.30 PROBLEM ON WRAPPING PART (498)

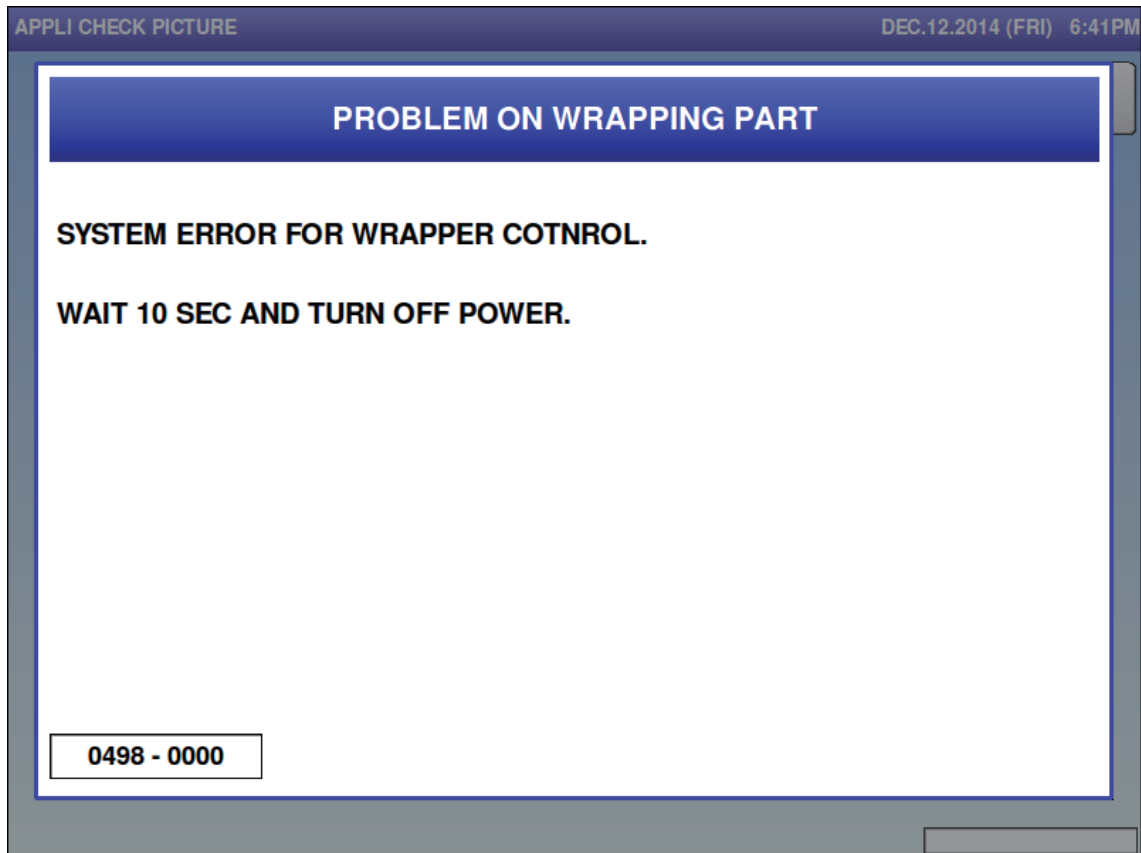

Error content	Wrapper system error
Details	A problem occurred in the wrapper program.
Release method	Power on again.
User's action	
Service person's action	
Related location	
Remarks	

1.31 FAILED TO OUTFEED THE ITEM (524)

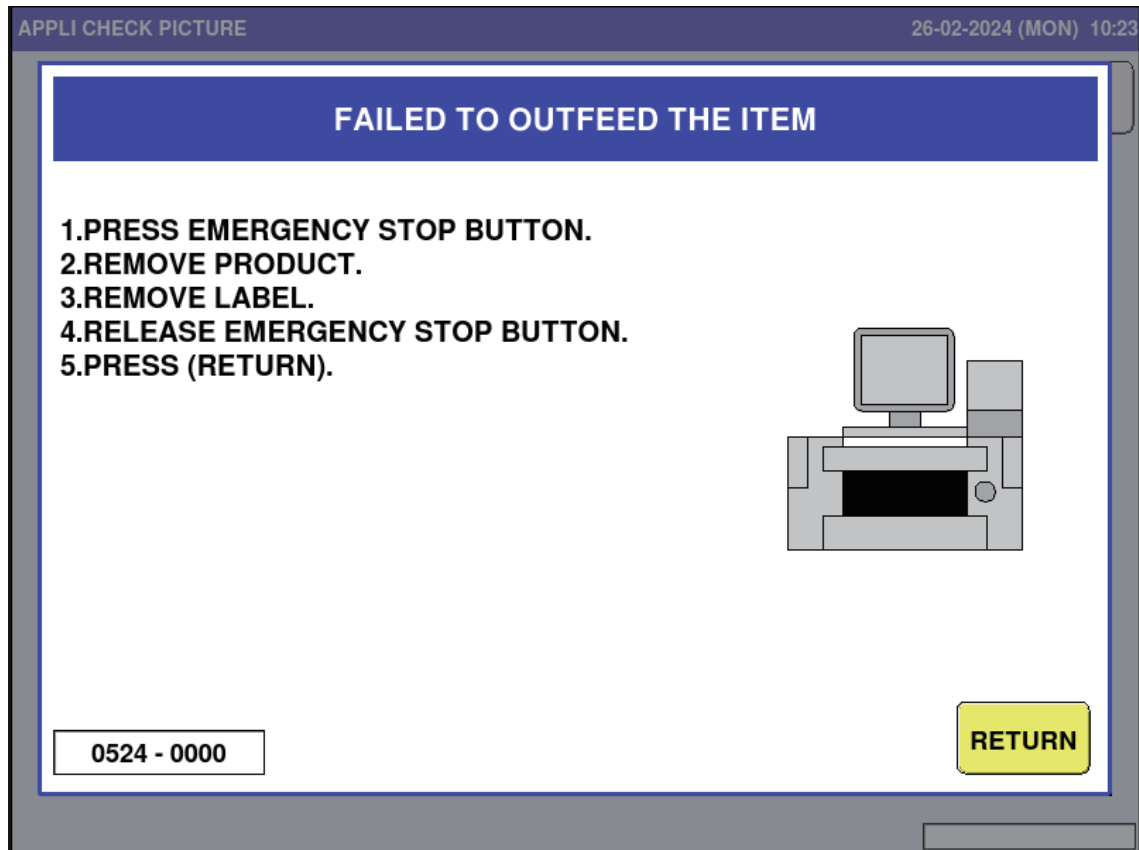

Error content	Failed to discharge the product.
Details	<p>The outfeeder product detection sensor on the outfeeder was not blocked from light when the item was wrapped.</p> <ul style="list-style-type: none"> • The product fell into the wrapper while being discharged. • The outfeed operation was performed while the product was not in the wrapper. For example, the product was removed after weighing stabilization and before supply.
Release method	Press the [RETURN] button.
User's action	
Service person's action	
Related location	<p>(1) P-1186 [A1] (2) Outfeeder product detection sensor (light emitting) [B5], Outfeeder product detection sensor (light receiving) [B8].</p>
Remarks	Perform origin return processing after removing the product in the wrapper.

1.32 REMOVE PRODUCT

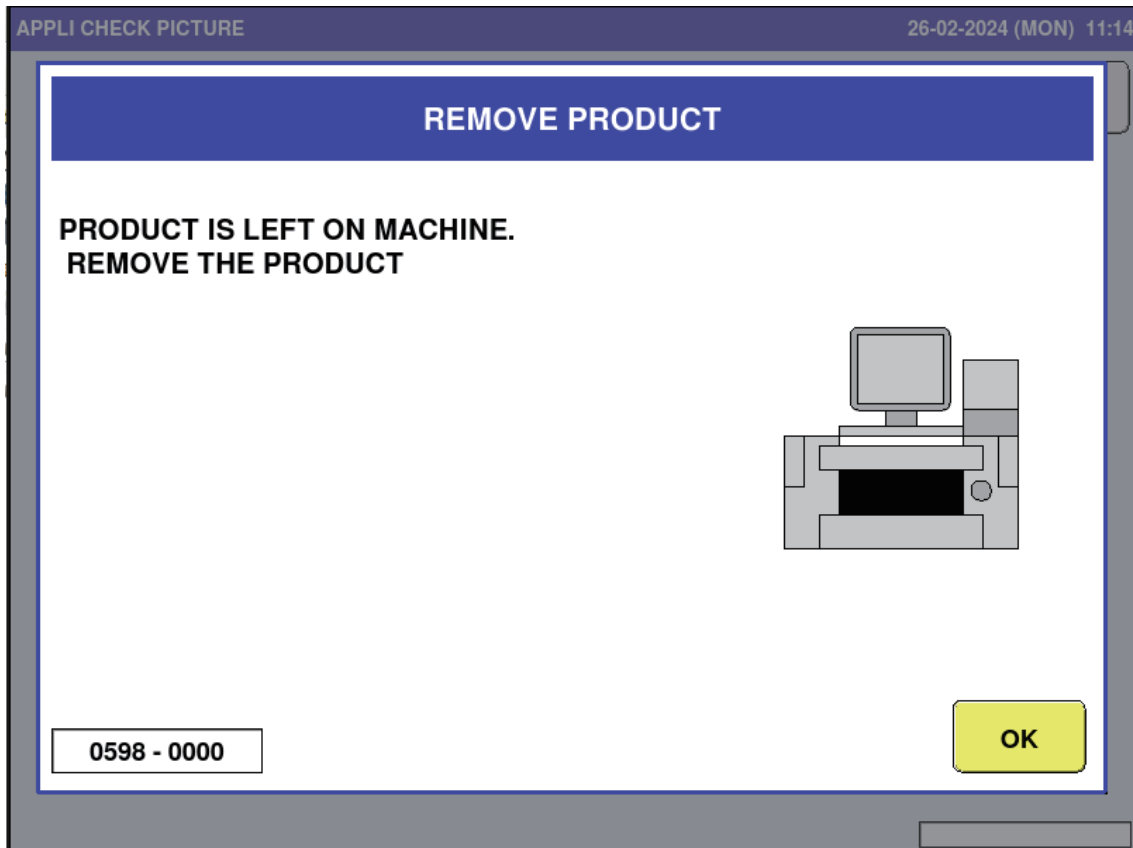

Error content	Remove the product from the outfeeder.
Details	The next production was carried out with the product remaining in the outfeeder.
Release method	Remove the product on the outfeeder.
User's action	
Service person's action	
Related location	
Remarks	

7.3.5 Error related to Printer (Code 700s)

1. Printer-related Errors

1.1 PRINTER 1 HAS PROBLEM (703)

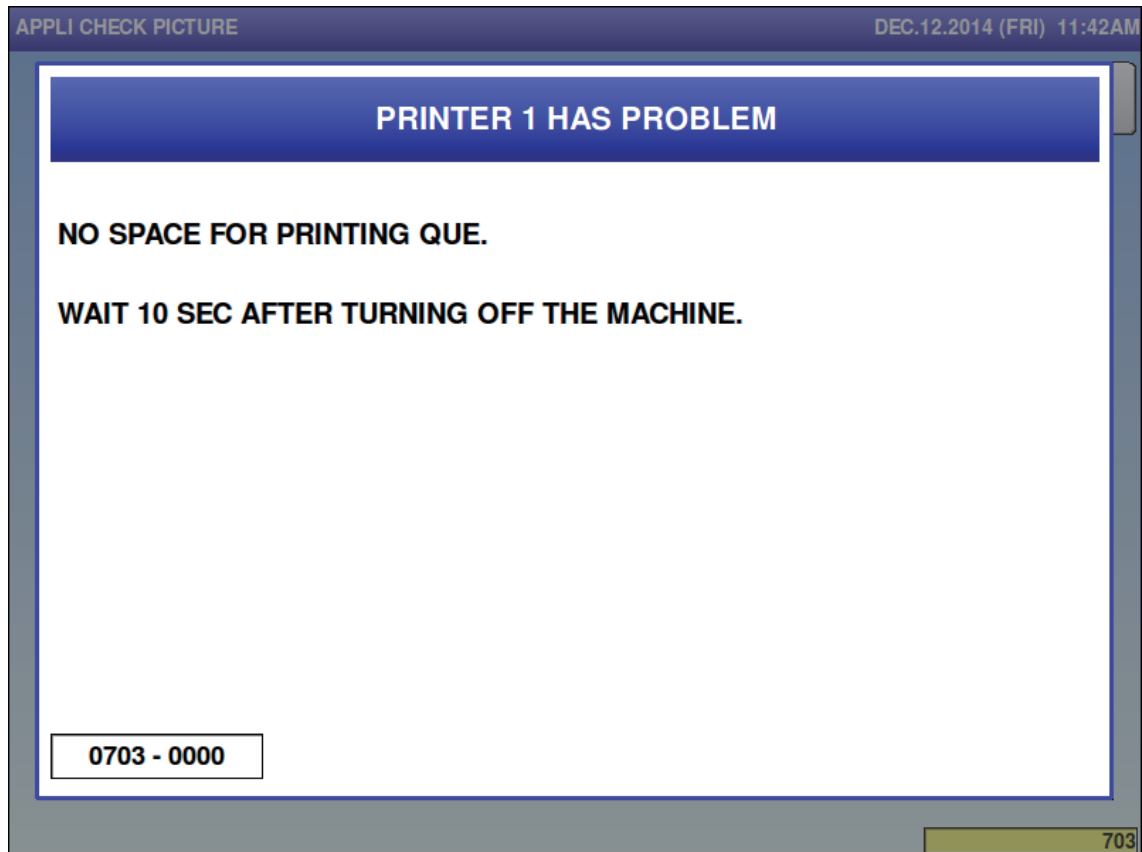

Error content	Printer system error
Details	The print sequence of the main program became abnormal.
Release method	Turn the power back ON.
User's action	
Service person's action	
Related location	
Remarks	Printer 1 changes depending on the error number.

1.2 PRINTER 1 HAS PROBLEM (704)

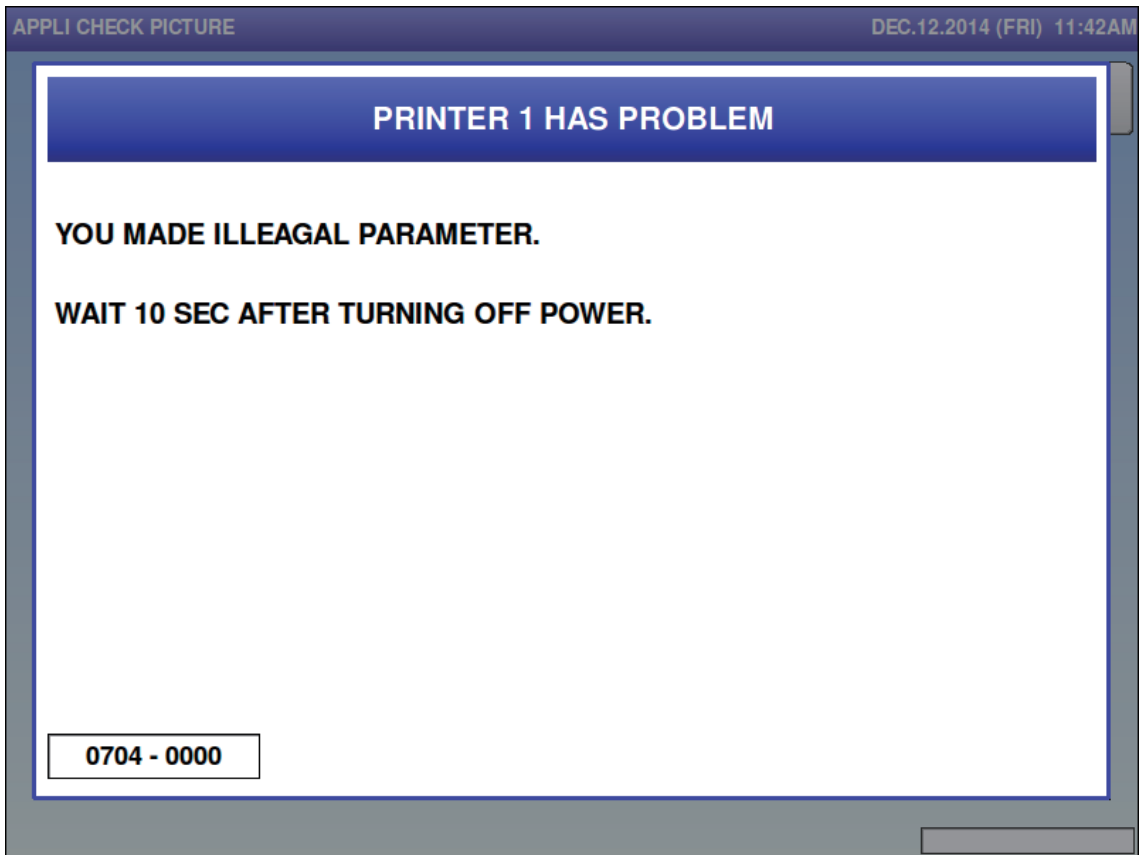

Error content	System error of the printer
Details	An unauthorized parameter was processed.
Release method	Turn the power back ON.
User's action	
Service person's action	
Related location	
Remarks	Printer 1 changes depending on the error number.

1.3 PRINTER 1 IS NOT INITIALIZED (707)

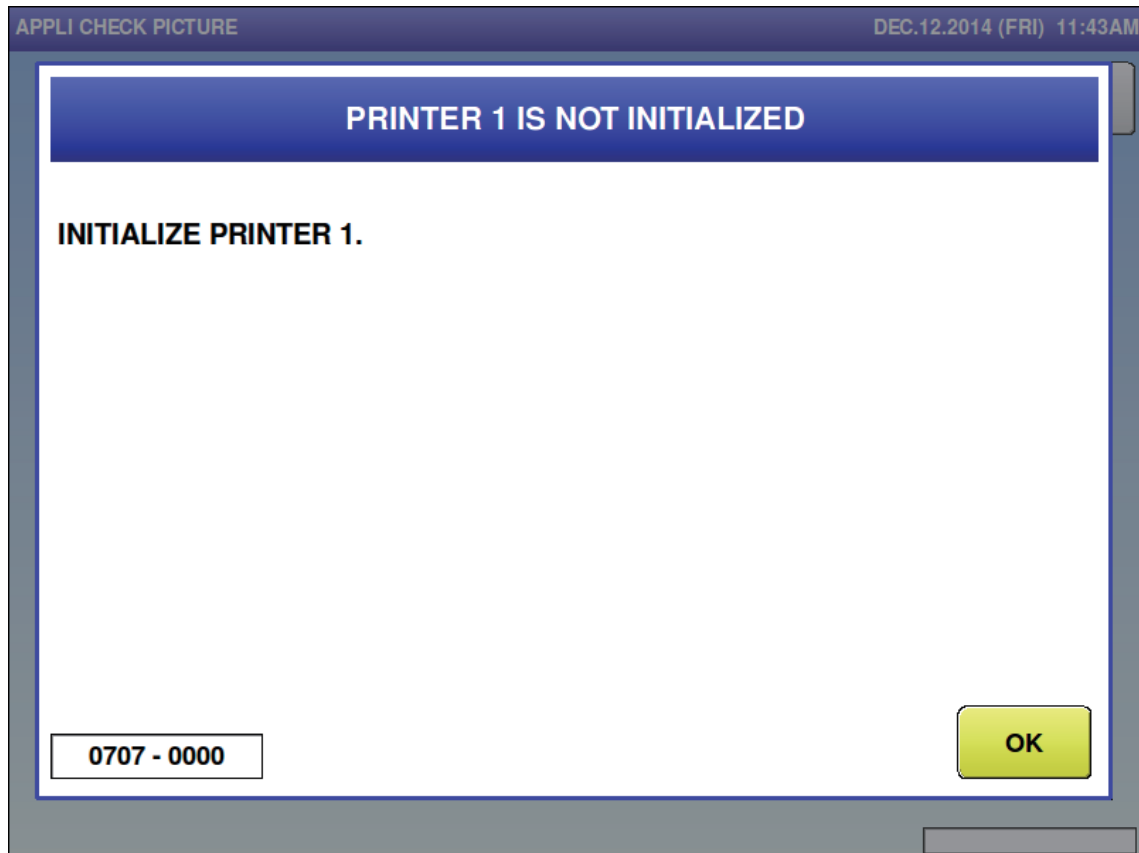

Error content	The printer is not initialized.
Details	Printer initialization has not been completed.
Release method	Press the [OK] button.
User's action	
Service person's action	
Related location	
Remarks	<ul style="list-style-type: none"> • Printer 1 changes depending on the error number. • Printer initialization must be performed under "Adjust: Printer".

1.4 NO LABEL FOR PRINTER 1 (710-0002)

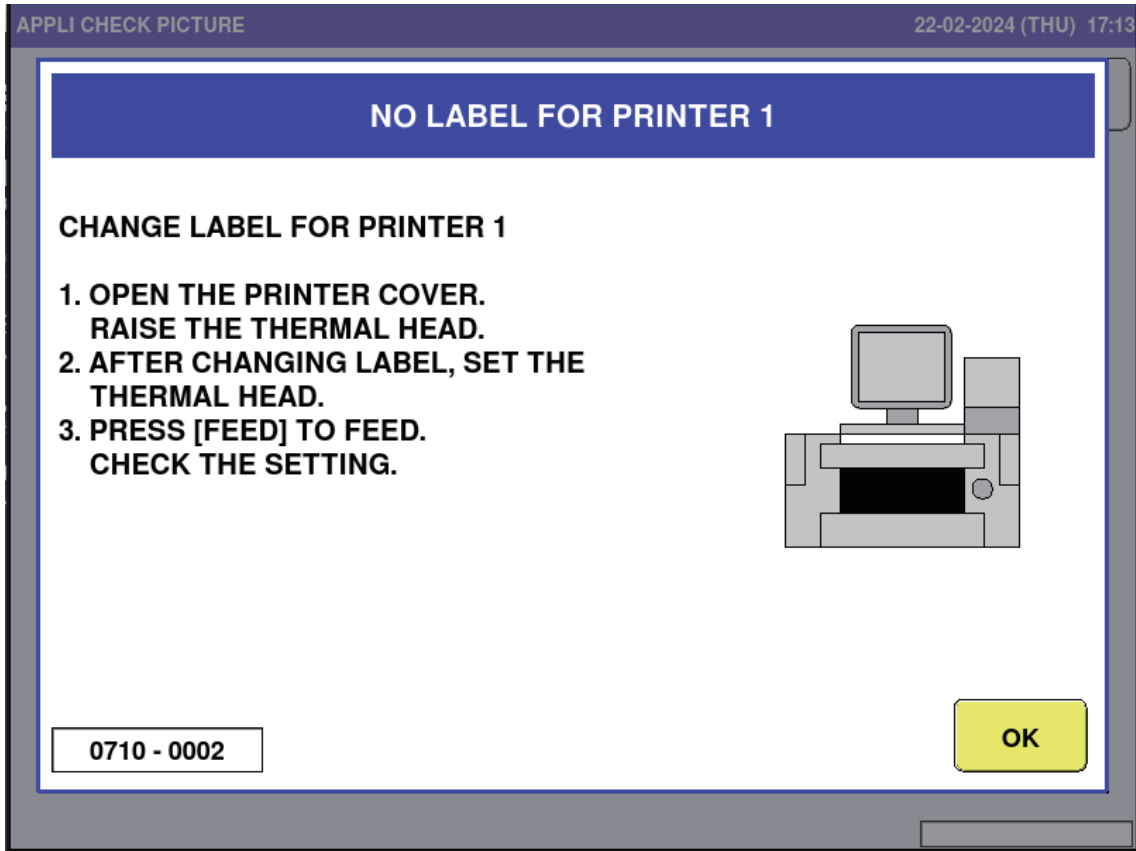

Error content	The printer has run out of labels.
Details	Displayed when labels are finished at the time of label issuance.
Release method	After replacing labels, perform a feed operation.
User's action	
Service person's action	
Related location	
Remarks	Printer 1 changes depending on the error number.

1.5 LABEL SIZE ERROR FOR PRINTER 1 (711-0002)

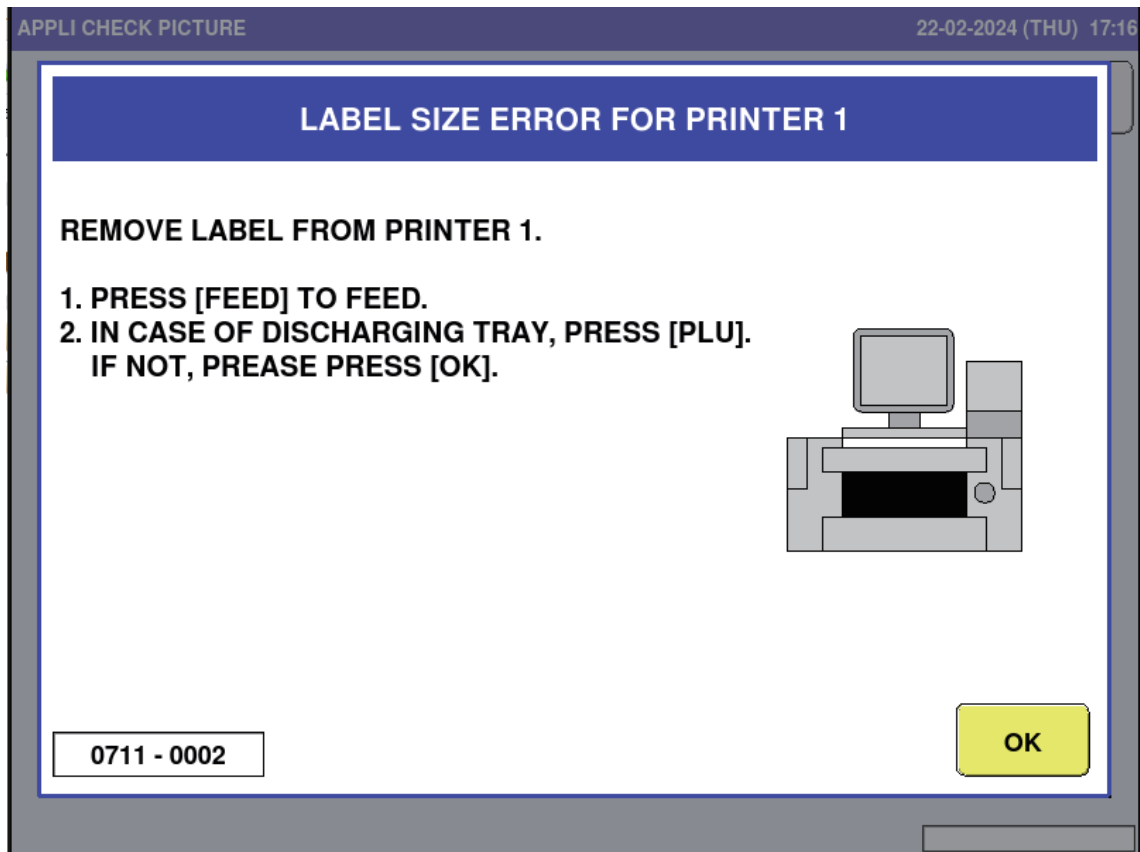

Error content	Printer label size error
Details	Displayed when the format size of the production label differs from the actual label size.
Release method	Remove the label by performing a feed operation.
User's action	
Service person's action	
Related location	
Remarks	Printer 1 changes depending on the error number. Check the format of the label to be printed.

1.6 TOO MANY CHARACTERS ON FORMAT FOR PRINTER 1 (713)

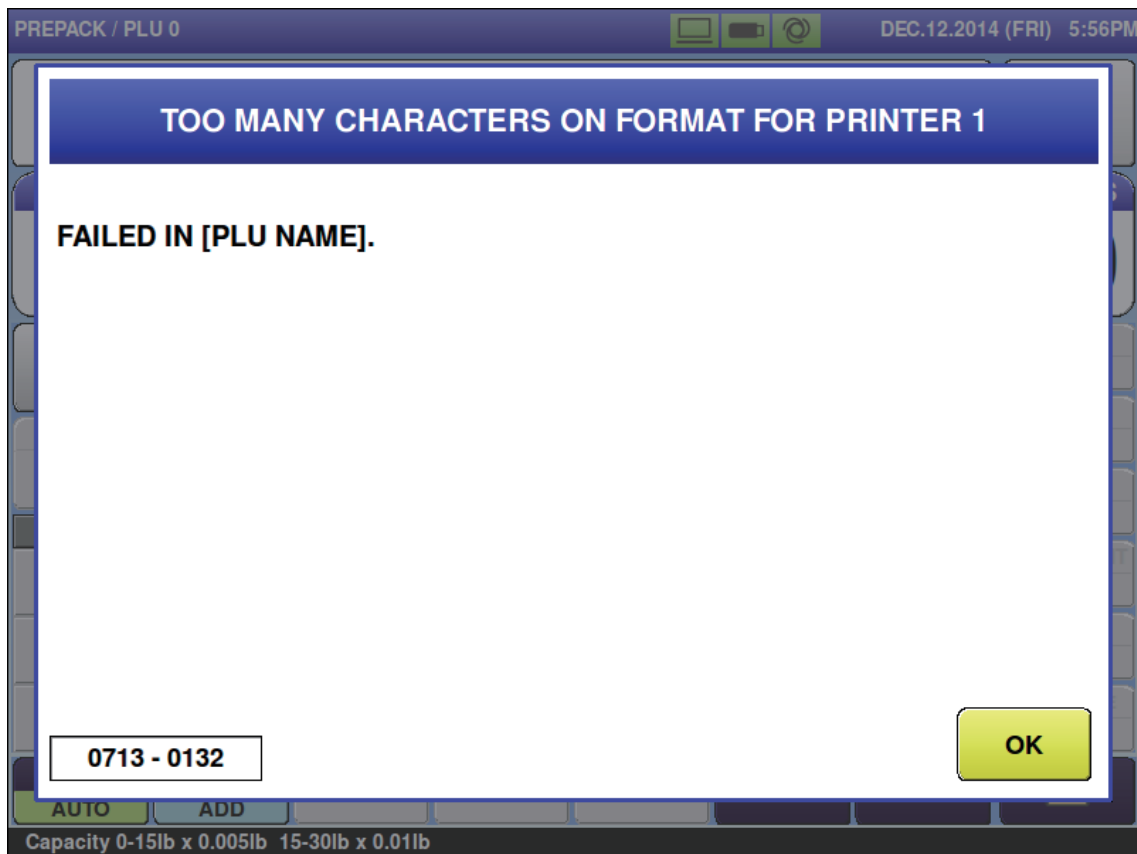

Error content	Failed to expand printer.
Details	Item information for which expansion failed is added to the sub-error number.
Release method	Press the [OK] button.
User's action	
Service person's action	
Related location	
Remarks	Printer 1 changes depending on the error number. Check the format of the label to be printed.

1.7 THERMAL HEAD IS WORN OUT FOR PRINTER 1 (715-0001)

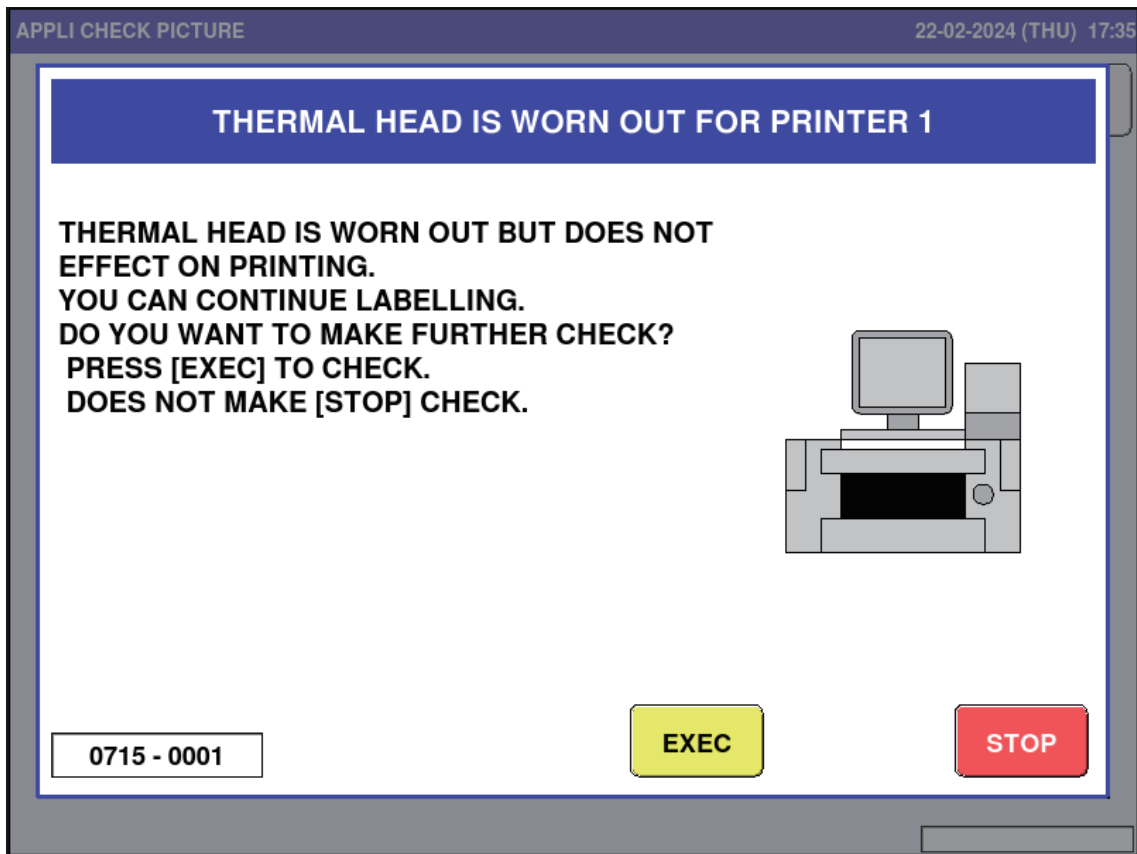

Error content	Dots on the thermal head of the printer are defective.
Details	The affected area is separated by a sub-error number. 0001: Defective in an area that does not affect printing.
Release method	Press the [EXEC] button or the [STOP] button. [EXEC]: The head check is executed for the next product. [STOP]: The head check is NOT executed for the next product.
User's action	
Service person's action	
Related location	
Remarks	Printer 1 changes depending on the error number.

1.8 THERMAL HEAD IS WORN OUT FOR PRINTER 1 (715-0002)

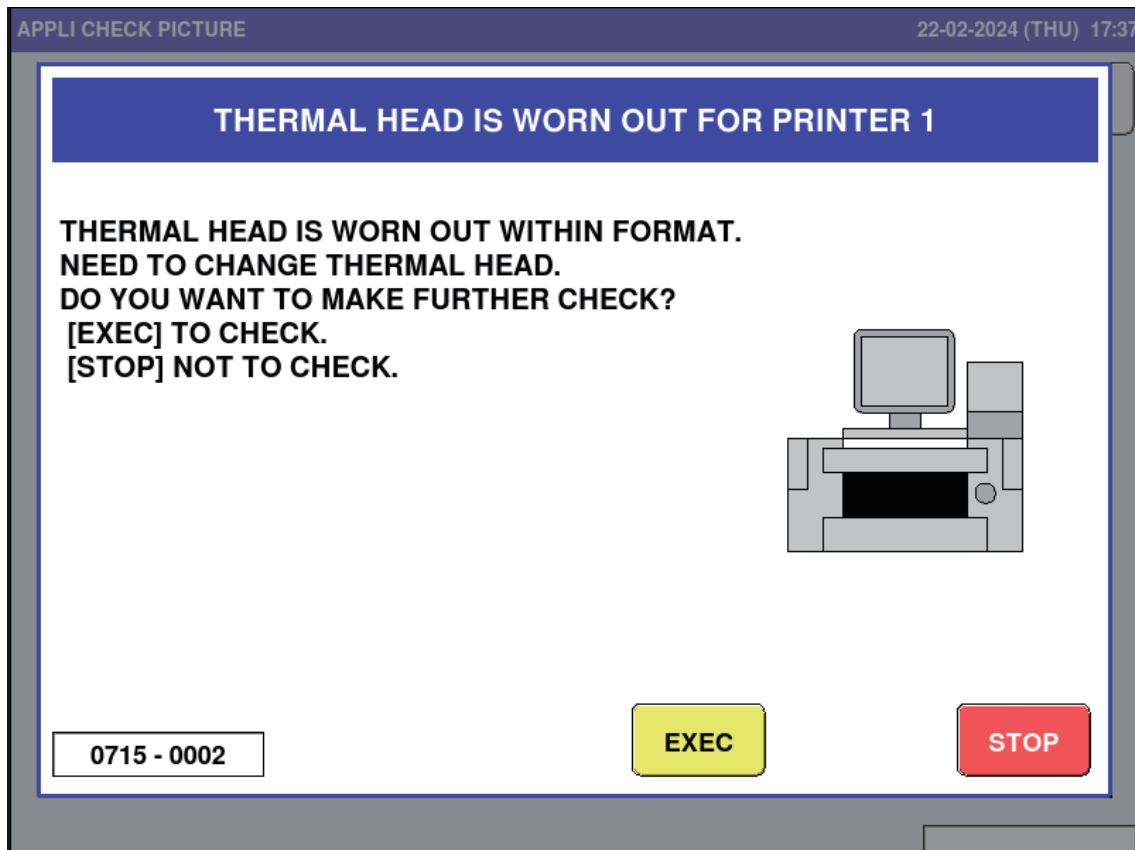

Error content	Dots on the thermal head of the printer are defective.
Details	The affected area is separated by a sub-error number. 0002: Dots are defective within the print format.
Release method	Press the [EXEC] button or the [STOP] button. [EXEC]: The head check is executed for the next product. [STOP]: The head check is NOT executed for the next product.
User's action	
Service person's action	
Related location	
Remarks	Printer 1 changes depending on the error number.

1.9 THERMAL HEAD IS WORN OUT FOR PRINTER 1 (715-0003)

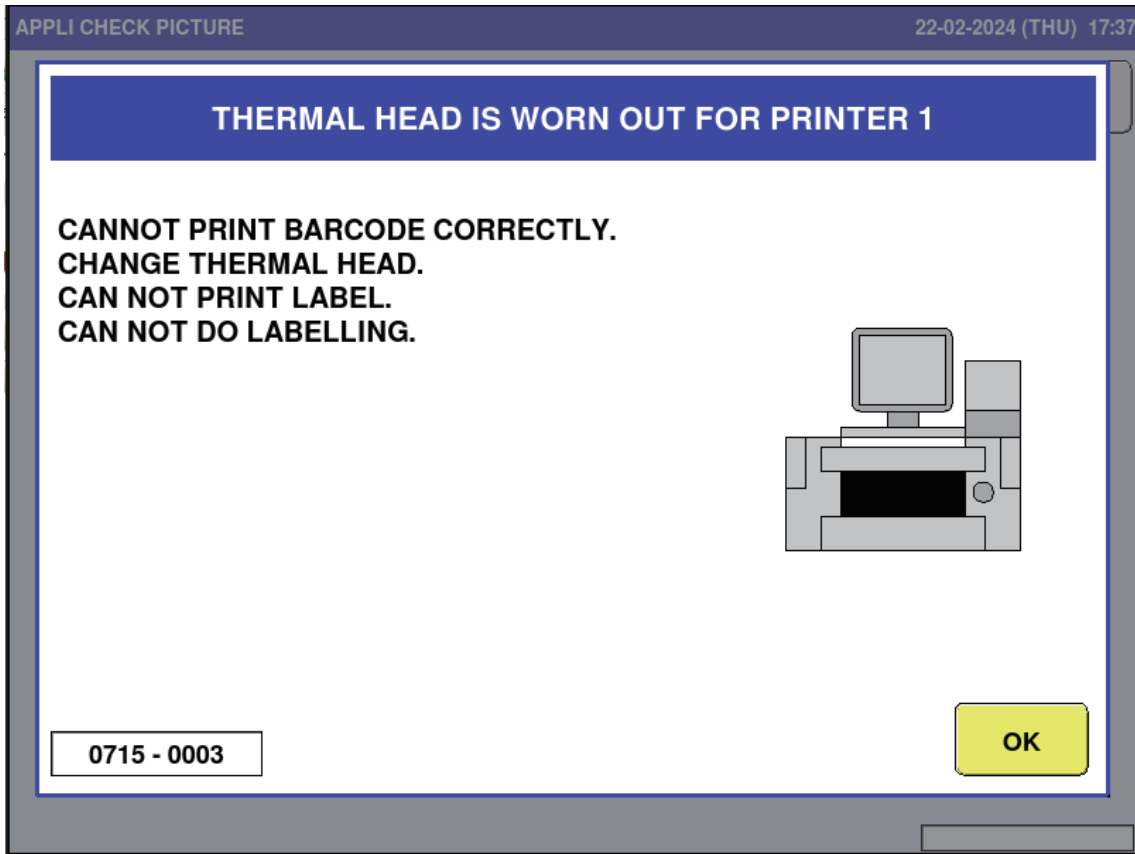

Error content	Dots on the thermal head of the printer are defective.
Details	The affected area is separated by a sub-error number. 0003: Dots in the barcode area are defective.
Release method	Press the [OK] button.
User's action	
Service person's action	
Related location	
Remarks	Printer 1 changes depending on the error number.

1.10 THERMAL HEAD FOR PRINTER 1 IS OPEN (716-0002)

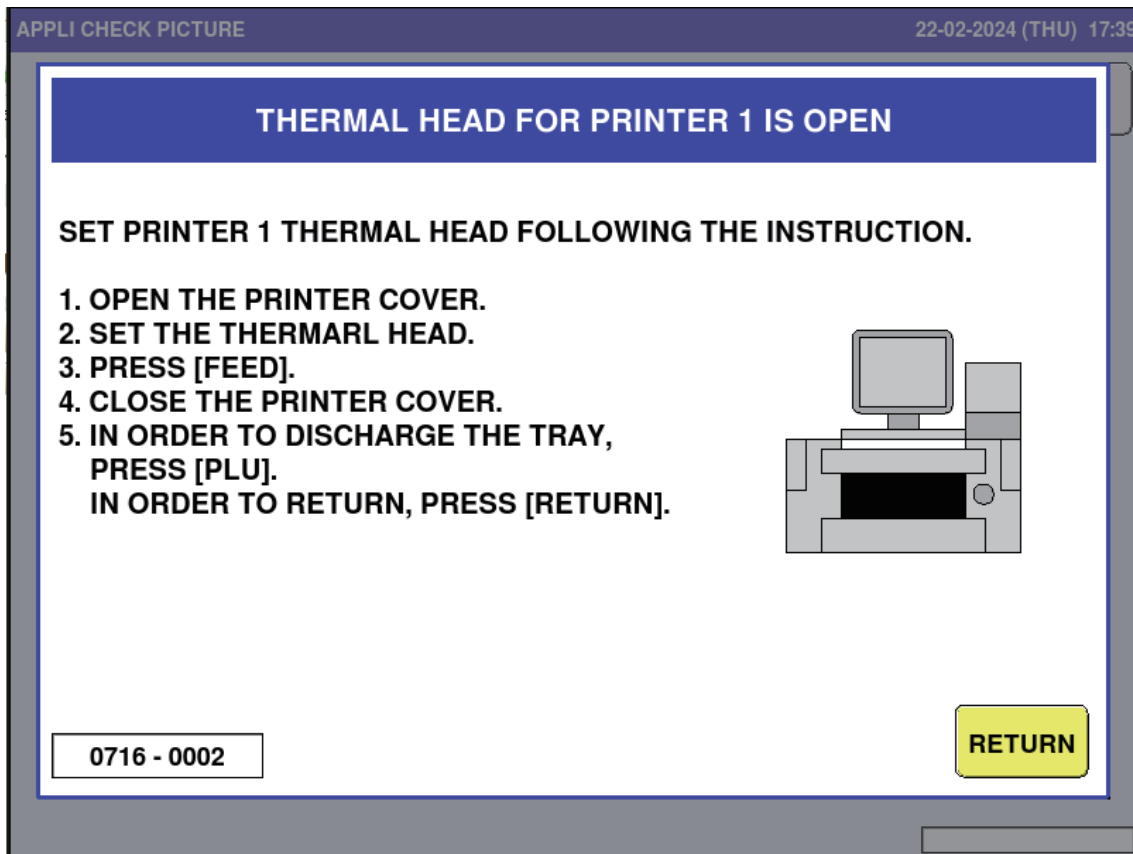

Error content	The thermal head of Printer 1 is up.
Details	The thermal head was raised at the start of printing or during printing. Displayed when the front cover is closed.
Release method	Press the [RETURN] button after setting the thermal head.
User's action	
Service person's action	
Related location	
Remarks	Printer 1 changes depending on the error number.

1.11 CONTROL BOARD FOR PRINTER 1 IS FAILED (717-0000)

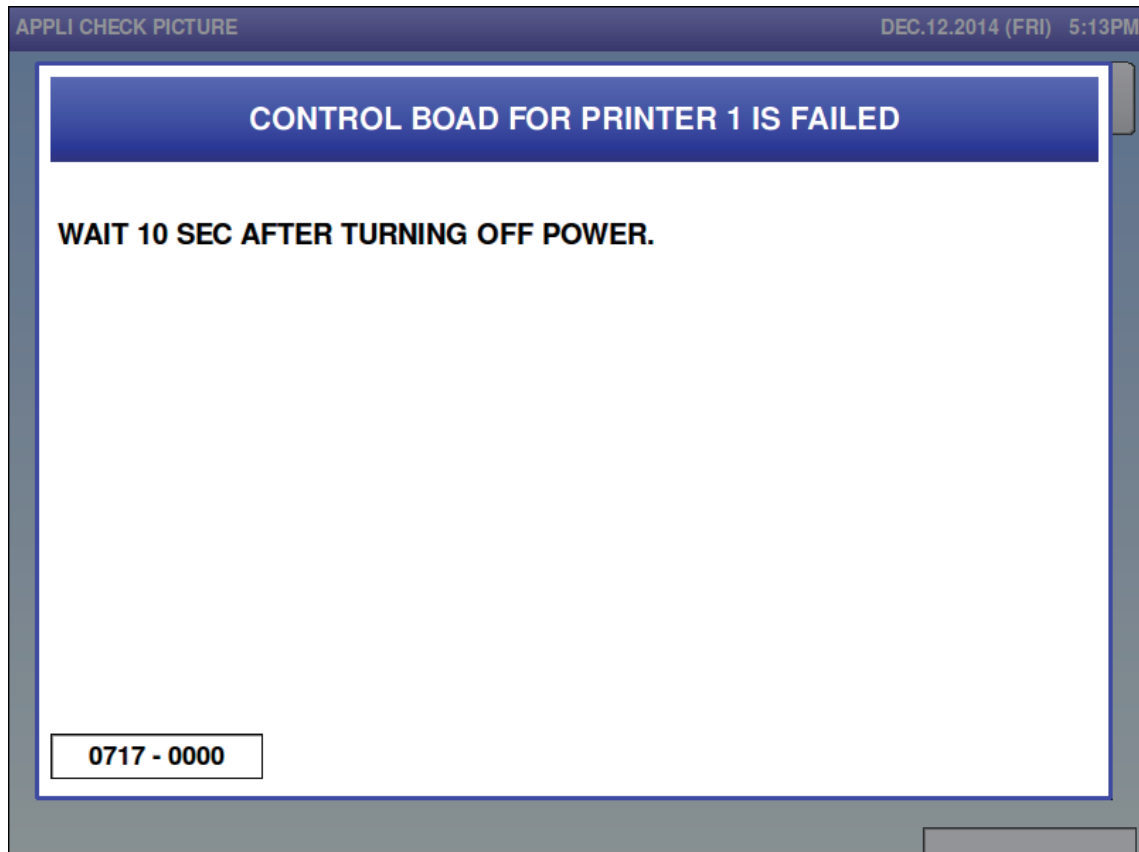

Error content	Printer control board (Printer 1: P-1180) failure
Details	An interrupt signal could not be detected from the printer control board (P-1180).
Release method	Turn the power back ON.
User's action	
Service person's action	
Related location	
Remarks	Printer 1 changes depending on the error number.

1.12 CUTTER COVER OF PRINTER 1 IS OPENED (768-0002)

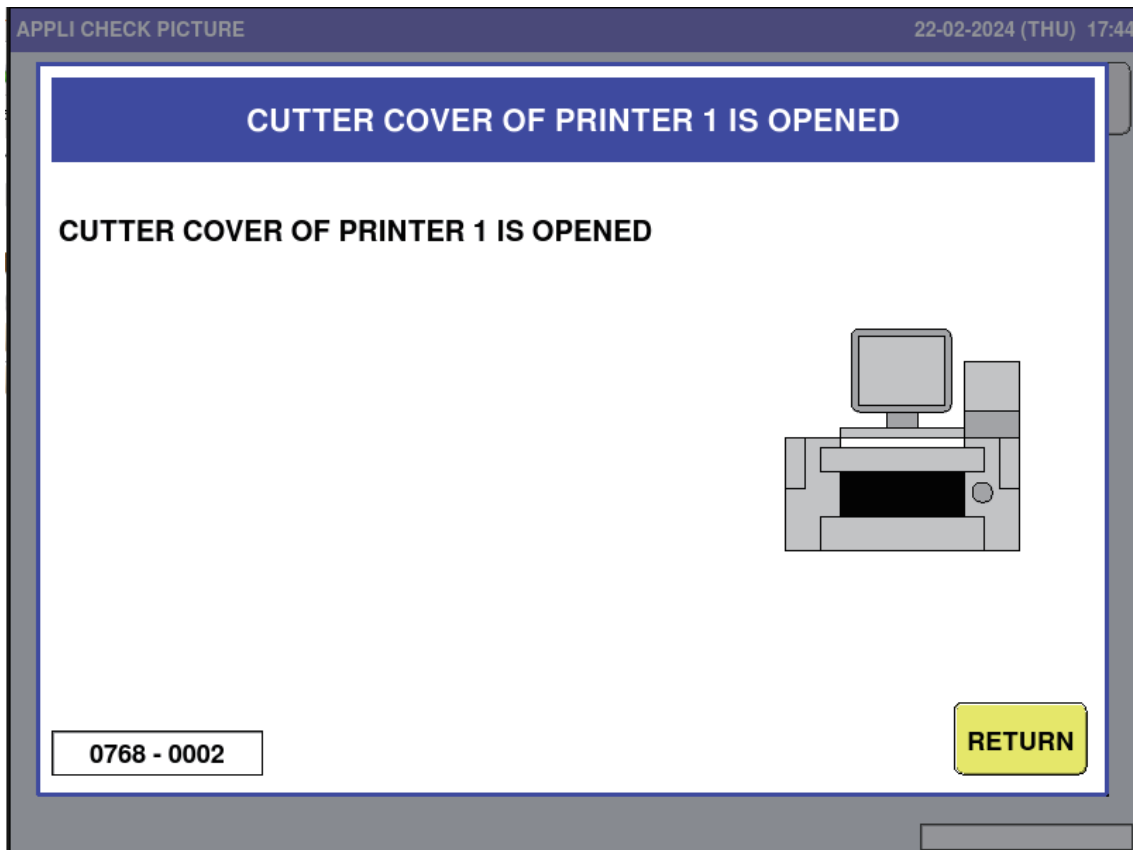

Error content	The cutter cover of Printer 1 has been opened.
Details	Displayed when the cutter cover is opened during label printing.
Release method	Set the cutter cover and perform a feed operation. After the feed operation, press the [RETURN] button.
User's action	
Service person's action	
Related location	
Remarks	

1.13 CUTTER OF PRINTER 1 IS ABNORMAL (769-0002)

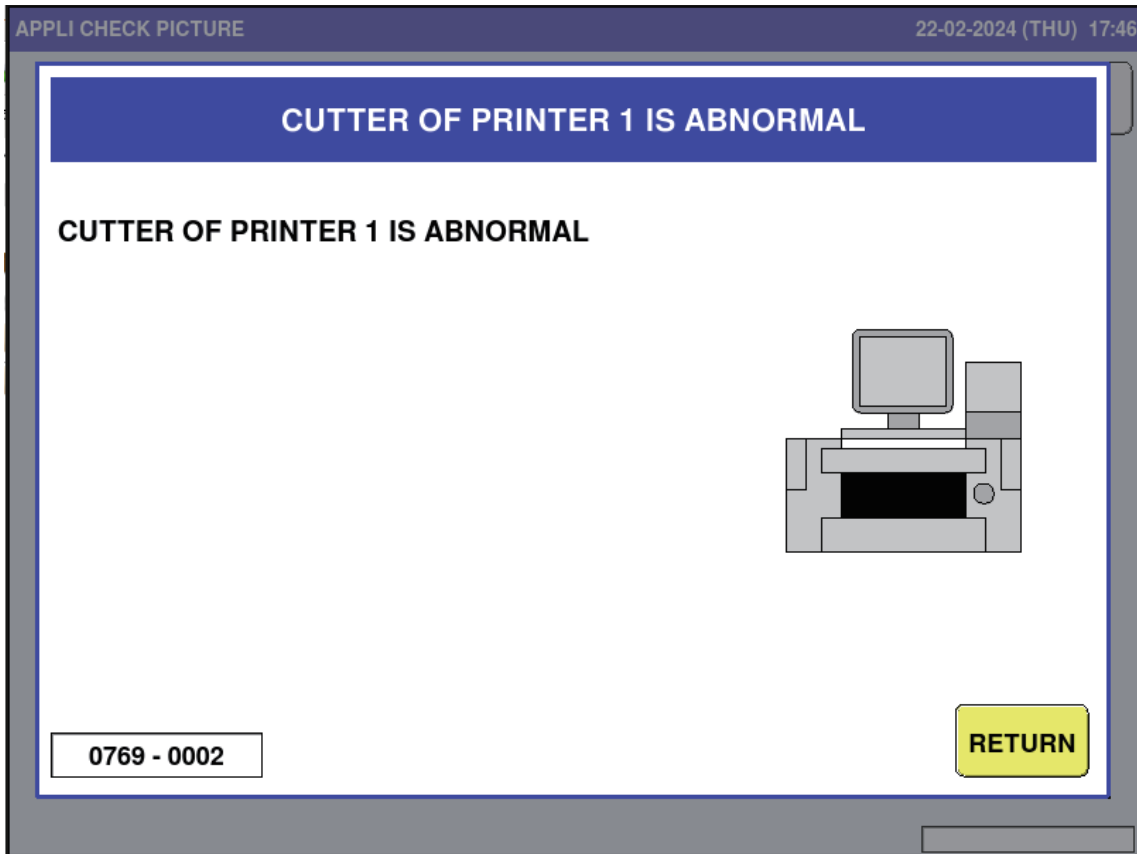

Error content	The cutter of Printer 1 is abnormal.
Details	Displayed when the cutter origin sensor is not blocked from light during cutter operation.
Release method	Press the [RETURN] button. Note: Cutter unit replacement or cutter origin sensor adjustment is required.
User's action	
Service person's action	
Related location	
Remarks	

1.14 FAILED TO PRINT LABEL (770-0002)

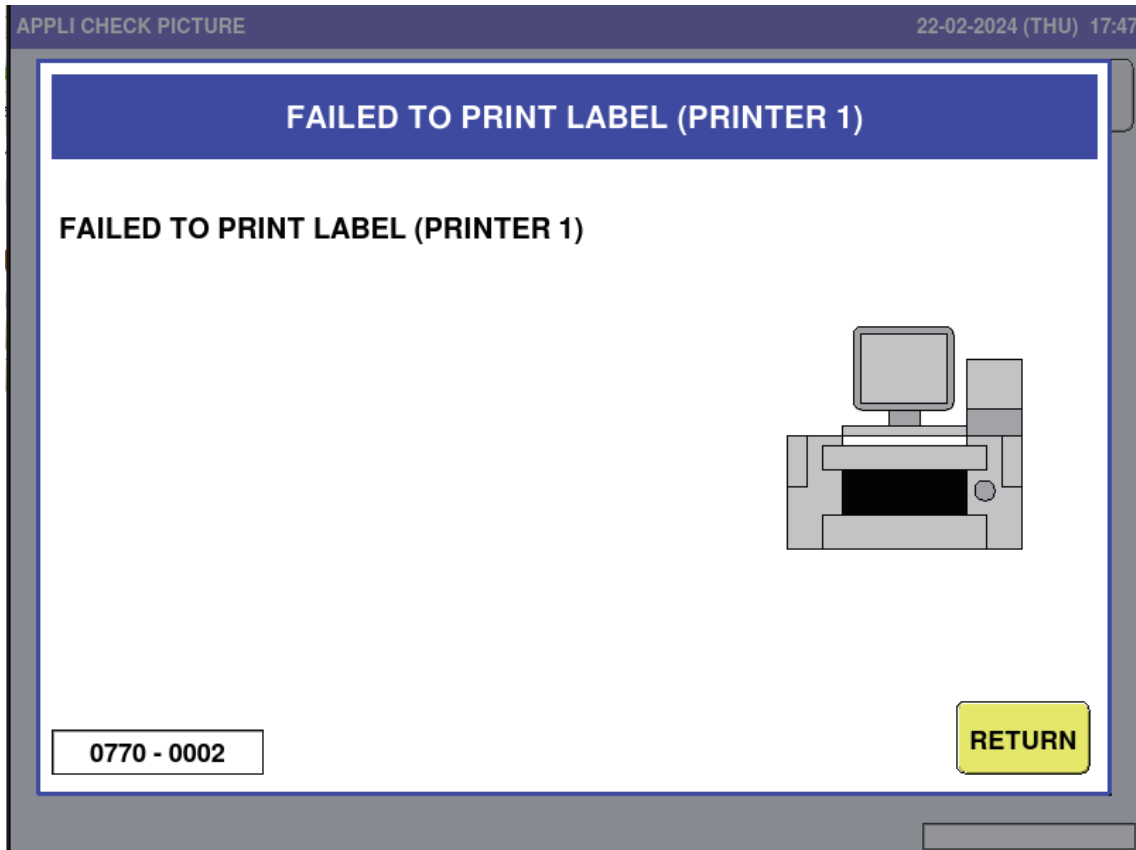

Error content	Failed to print a label on Printer 1.
Details	Displayed when the peeling sensor is not blocked from light when printing a label.
Release method	Re-load the labels and press the [RETURN] button. After pressing the button, perform a feed operation.
User's action	
Service person's action	
Related location	
Remarks	

7.3.6 Error related to Scale (Code 1600s)

ID NO.	TITLE	ERROR CONTENT	SOLUTION
1601	SPAN ADJUTMENT FOR SCALE IS NOT COMPLETED	Span adjustment for scale is not completed.	[OK] It is necessary to implement calibration.
1602	SCALE INITIALIZATION IS NOT COMPLETED	Initialization for scale is not completed.	[OK] It is necessary to implement calibration.
1618	CHECK SCALE	Check if anything is touching on the scale.	[OK] Ensure that nothing is in contact with the scale.
1619	TAKE ITEM OFF THE PLATTER	Check if there are any products on the scale.	[OK] Ensure that nothing is placed on the scale.
1620	SCALE IS BLACKOUT	Scale is blackout temporary.	[OK] Reboot the machine.
1621	NO RESPONSE FROM SCALE	There is no response from the scale.	[OK] Reboot the machine after confirming the connection of the scale.
1622	CANNOT COMMUNICATE WITH SCALE	Cannot communicate with the scale.	[OK] Reboot the machine after confirming the connection of the scale.
1623	CANNOT COMMUNICATE WITH SCALE	Cannot communicate with the scale.	[OK] Reboot the machine after confirming the connection of the scale.
1626	WRAP WEIGHT LIMIT ERROR	Remove the item from the scale platter. It appears when an item is too heave to wrap. (M: 1.5kg, L: 3.5kg) <Sub-Error> 0000:M type 0001: L type	[OK] It is available to function only with [Print] mode.

Appendix 1 Wrapping by WM-MICRO

1.1 PART NAMES

Names of each part are given in Figures 1 and 2.

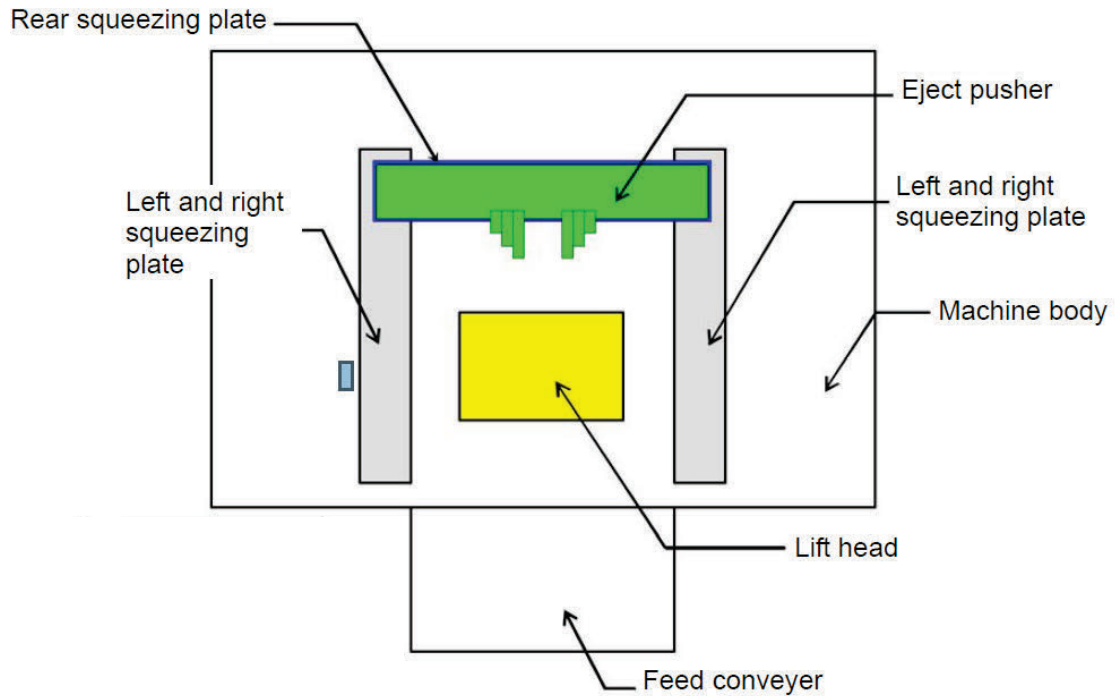

Figure1 Names of the wrapping unit(overhead view)

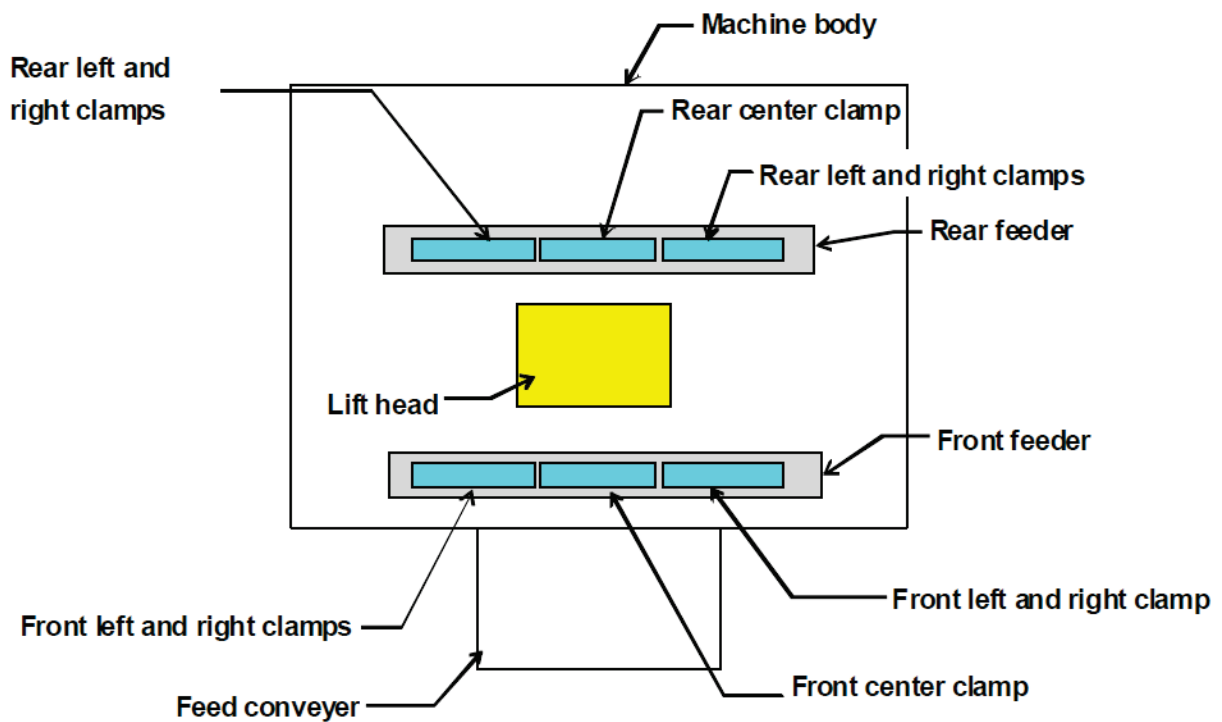

Figure2 Names of the feeder unit(overhead view)

1.2 WRAPPING OPERATION

1) Basic steps of wrapping operation

1. After the scale has stabilized, start film conveying and tray feeding.
2. After completing film conveying, start lift elevation.
3. After completing lift elevation, left and right squeezing plates squeeze in (Figure 4).
4. After the squeezing plates reach the position to hold the tray, the lift starts descending (Figure 5).
5. After the lift started descending, the left and right squeezing plates and rear squeezing squeeze in (Figure 5)
6. The eject pusher ejects the tray (figure 6).

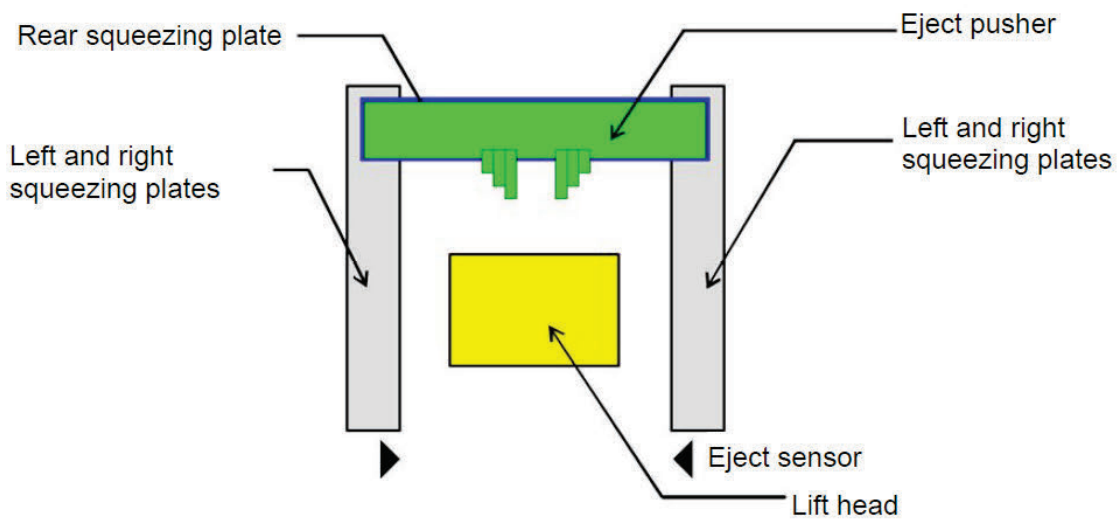

Figure 3 Original position

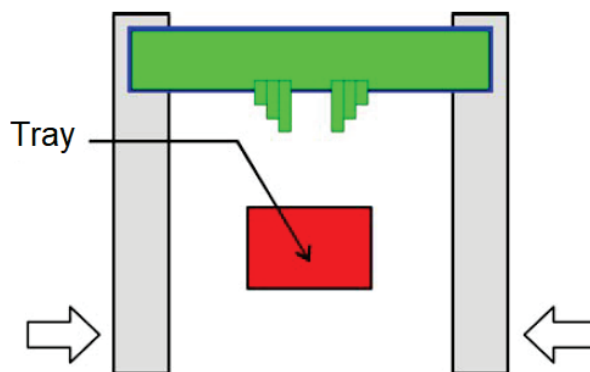

Figure 4 Lift elevation complete

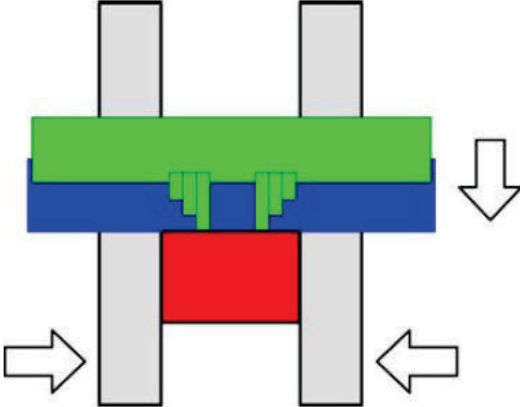

Figure 5 Lift starts descending.

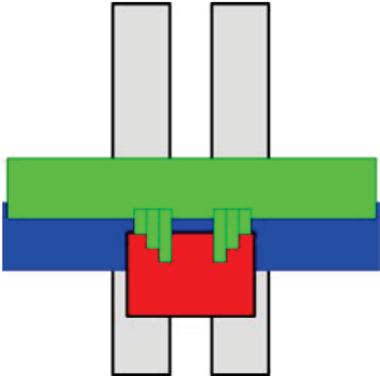

Figure 6 Left and right squeezing plates and rear squeezing plate finish squeezing.

Appendix 2 Electric Wiring Diagram

2.1 Page 1

1) ※1 LL when connecting X130R and X130P.
L if not connected.

ハイセンス「WM-MICRO」PAGE1
100-061-4712-00

Constantly energized parts

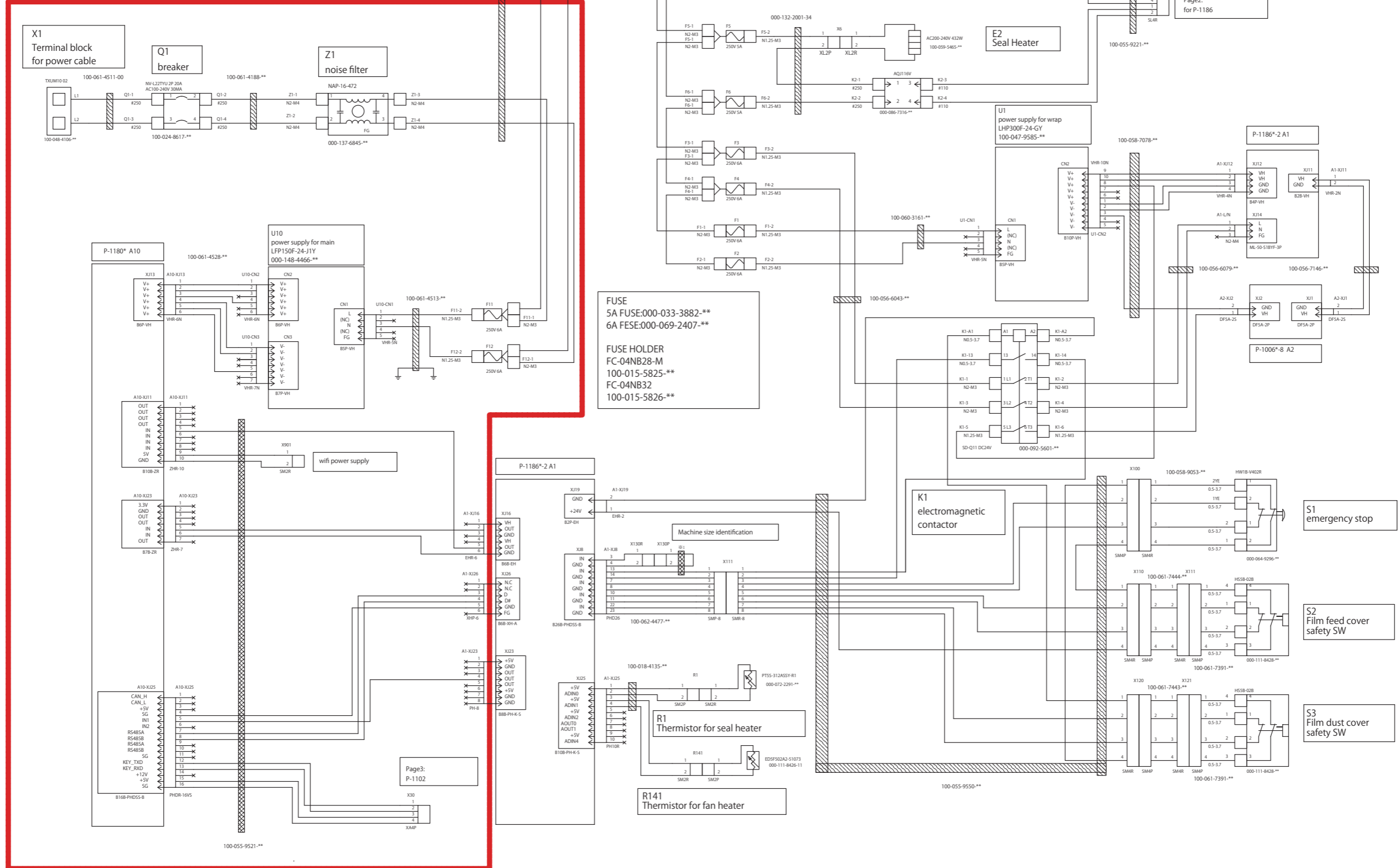

2.2 Page 2

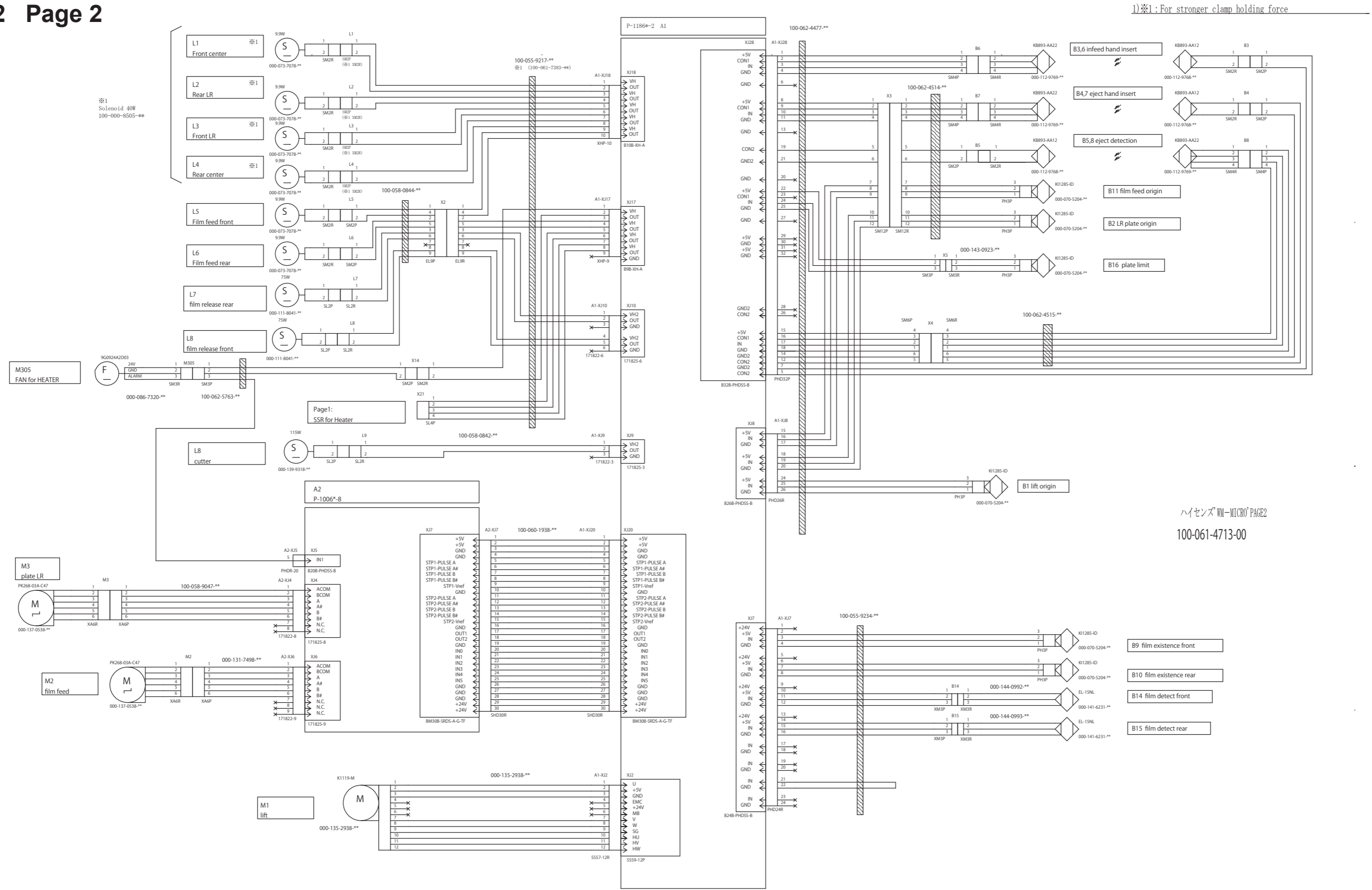

1)※1: For stronger clamp holding force

※1 Solenoid 40W 100-000-8505-**

ハイセンス™-MICRO PAGE2 100-061-4713-00

2.3 Page 3

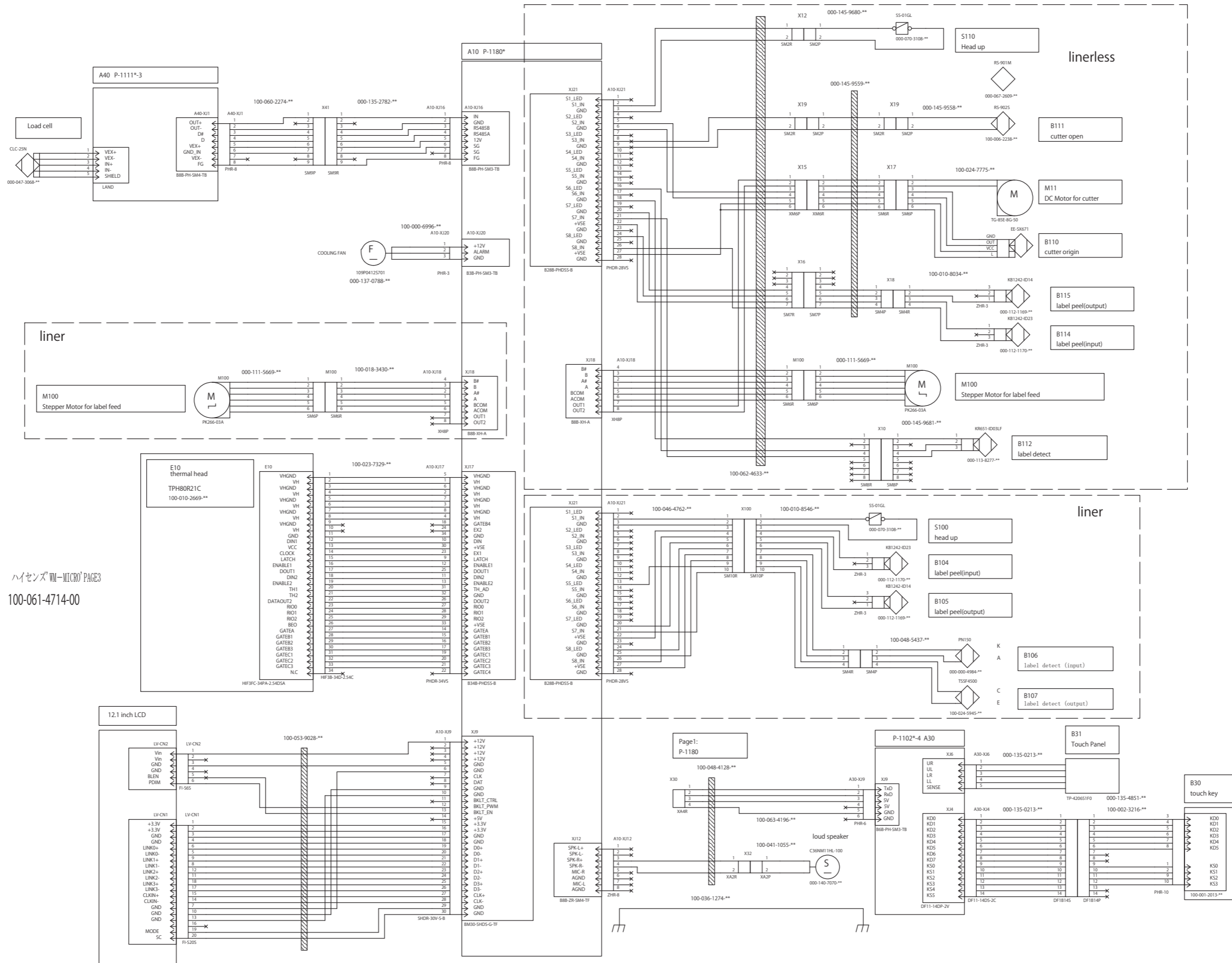



© Rice Lake Weighing Systems Content subject to change without notice.

230 W. Coleman St. • Rice Lake, WI 54868 • USA USA: 800-472-6703 • International: +1-715-234-9171