

Ishida IP-Ai

Prepack Scale & Printer

Service Manual



February 27, 2023

RICE LAKE
RETAIL SOLUTIONS

ISHIDA

PN 179840 Rev B

Revision History

Version	Date	Description
1	January 2015	First edition
2	May 2015	Reflected specifications changes. Corrected erroneous description.
3	December 2015	Reflected specifications changes. Added an optional item to mechanical adjustment.
4	May 2016	Corrected erroneous description.
5	November 2017	Reflected specifications changes. -Weighing type and Weighing accuracy- Added 30kg(1/6000) / 60lb(1/6000) to "5.10 CALIBRATION".
6	April 2021	Added "5.10.1 Procedure for adjusting scale(span)" in "Chapter 5 Adjust Mode".
7	October 2021	-Added Technical Reports SC216131"About the version change of P-1111 board" at the beginning. -Added the notification about SC216131 at "2.4 Replacing the Weighing Unit".
8	September 2022	Added "Precautions on Software Write after Board Replacement" to "5.12.1 DOWNLOAD (MAIN)" and "DOWNLOAD (SUB APP.)" in "Chapter 5 Adjust Mode."
9	January 2023	-Added Technical Reports SC226141"Version change of P-1111 board (return to original)"at the beginning. -Added the notification about SC226141 at "2.4 Replacing the Weighing Unit".
10	February 2023	-Updated images, illustrations, dimensions and charts; added and adjusted text



WARNING

- Do not carry out installation, operation, service, or maintenance until thoroughly understanding the contents of this manual.
- Keep this manual available at all times for installation, operation, service, and maintenance.

The use of this manual is for our service personnel and persons authorized to carry out maintenance work of this machine. The use of this manual by any person other than the above is strictly prohibited.

ISHIDA CO., LTD.

Issued in November 2015
Revised in January 2023

Introduction

● Purpose of this Manual

The purpose of this manual is as reference material for the delivery, installation, repair and maintenance of the IP-AI.



● Target Readers



This manual has been written specifically for use by our service personnel.
The use of this manual by any person other than the above is strictly prohibited.

● Related Manuals

Manual Name	Content
IP-AI Instruction Manual	Instruction Manual (included in the package of that product)

● Meanings of Signal Words

Signal Word	Meaning
 DANGER!	Indicates a potentially hazardous situation, which, if not avoided, will result in severe injury or death.
 WARNING	Indicates a potentially hazardous situation, which, if not avoided, could result in severe injury or death.
 CAUTION	Indicates a potentially hazardous situation, which, if not avoided, may result in minor or moderate injury or in property damage.

Signal Word	Meaning
NOTE:	Indicates information that needs to be noted or emphasized.
 INFORMATION	Indicates the reference information.
 REFERENCE	Indicates the reference page.

It is strictly prohibited to copy or reproduce part or all of this manual without prior approval by the copyright holder.

Information

About the version change of P-1111 board

Document No:	SC216131	Category	UNI-9, IP/WM-AI, IZ-7000, MS-AcroII
Issue date:	6 October 2021	Approved:	T. Ando
Checked:	A. Hattori	By:	N. Izumi

Technical Reports are issued for our agencies/distributors. Please handle carefully not to pass them directly to customers.

[Contents]

Due to the shortage of parts supply, the CPU used in each weigher's scale board (P-1111) will be replaced with an alternative CPU.

[Details]

Refer to the table below for the compatibility with the current Item Code.

Although the Item Code will be changed, compatible boards can be replaced in the same way as before.

Notes: The board with a different branch number (A-5, 6, 7) cannot be used.

Be sure to use a compatible board.

We will inform you as soon as the change is complete for devices that have not yet been changed.

Before replacement			After replacement			Product
Item Code	Board Name	Branch No.	Item Code	Board Name	Branch No.	Model
000-130-7000-65	P-1111	A	100-047-9979-00	P-1111	A-5	IZ-7000(S,IT,IW) UNI-9(weigh unit 30kg), IP-AI (overseas: 30kg), IZ-7000(M), MS-Acro2
000-139-2566-18	P-1111	A-1	100-047-9980-00	P-1111	A-6	UNI-9 (weigh unit other than 30Kg)
100-003-3404-04	P-1111	A-2	100-047-9981-00	P-1111	A-7	WM-AI, IP-AI

The change has been made sequentially from the machines manufactured around the end of August. For maintenance parts, the changed board will be shipped as soon as current one run out of stock.

Information

Version change of P-1111 board (return to original)

Document No:	SC226141	Category	UNI-9, IP/WM-AI, IZ-7000, etc.
Issue date:	21 December 2022	Approved:	A. Hattori
Checked:	Y. Fujiwara	By:	N. Izumi

Technical Reports are issued for our agencies/distributors. Please handle carefully not to pass them directly to customers.

[Contents]

As described in the previously issued SC216131, a CPU used in each weigher's scale board (P-1111) has been replaced with a replacement CPU due to the shortage of parts supply. This time, we inform you that the above measure is completed.

The scale board will be returned to the one with the original CPU from now on.

[Details]

Refer to the tables below. There is no problem with the same board replacement procedure as before.

Maintenance parts will also be returned to the board with the original CPU in order.

<Notes>

The boards listed in the table for each model are fully compatible with each other.
Be sure to use a compatible board for each model.

Board with original CPU			Board with replacement CPU			Product
Part code	Board name	Branch No.	Part code	Board name	Branch No.	Model
000-130-7000-66	P-1111	A	100-047-9979-01	P-1111	A-5	IZ-7000(S,IT,IW) UNI-9(weigh unit 30kg), IP-AI(overseas: 30kg), IZ-7000(M), MS-Acro2

Board with original CPU			Board with replacement CPU			Product
Part code	Board name	Branch No.	Part code	Board name	Branch No.	Model
100-054-0678-00	P-1111	A-1	100-047-9980-01	P-1111	A-6	UNI-9 (weigh unit other than 30Kg)

Board with original CPU			Board with replacement CPU			Product
Part code	Board name	Branch No.	Part code	Board name	Branch No.	Model
100-003-3404-05	P-1111	A-2	100-047-9981-02	P-1111	A-7	WM-AI, IP-AI

Board with original CPU			Board with replacement CPU			Product
Part code	Board name	Branch No.	Part code	Board name	Branch No.	Model
100-054-0677-00	P-1111	A-3	100-046-8754-01	P-1111	A-4	WM-AI/SP (South Korea and China Only)

Table of Contents

Revision History	1
Introduction.....	2
Chapter 1 Overview.....	1-1
1.1 Specifications	1-1
1.2 Features.....	1-4
1.3 Name of Each Part	1-5
1.4 Dimensions	1-6
1.5 Items Required for Installation	1-7
1.6 Installation Space	1-8
1.7 Power Supply	1-9
1.8 Carry-in and Installation.....	1-10
1.8.1 Installation Procedure Check Sheet.....	1-10
1.9 Setup.....	1-11
1.9.1 Requirements for Setup.....	1-11
1.9.2 Setup Procedure.....	1-11
1.9.3 Operation Checks.....	1-13
1.9.4 Operation Explanation	1-13
1.9.5 Issuing a Warranty.....	1-13
Chapter 2 Mechanical Adjustment	2-1
2.1 Removing Case Covers.....	2-1
2.1.1 Case Body (Top).....	2-1
2.1.2 Case Body (Left Side).....	2-1
2.1.3 Case Body (Right Side)	2-2
2.1.4 Case Body (Rear)	2-2
2.1.5 Case Body (Scale Cable)	2-2
2.2 Replacing Prats.....	2-3
2.2.1 Replacing the Thermal Head	2-3
2.2.2 Adjusting the Thermal Head Position	2-4
2.2.3 Replacing the Print Roller	2-6
2.2.4 Replacing the Peeling Sensor.....	2-8
2.2.5 Replacing the Label Sensor.....	2-9
2.2.6 Replacing the Head Up Sensor	2-10
2.2.7 Replacing the Keyboard	2-11
2.2.8 Replacing the Main Board.....	2-12
2.2.9 Replacing the Power Supply Board	2-13
2.2.10 Replacing the Motor.....	2-14
2.2.11 Adjusting the Belt Tension	2-15
2.2.12 Replacing the Scale Cable.....	2-16
2.2.13 Adjusting the Ball Catch Position	2-17
2.3 Replacing the Display Unit.....	2-18
2.3.1 Replacing the Display Board.....	2-18
2.3.2 Replacing the Display	2-19
2.3.3 Replacing the Touch Panel	2-20
2.4 Replacing the Weighing Unit	2-21
2.5 Replacing the Numerical Keypad Cover (Optional).....	2-23
2.6 Wireless LAN kit overseas edition expansion (Optional)	2-24

2.7 Curling inward label correspondence (Optional).....	2-26
Chapter 3 Electric Components	3-1
3.1 PCB Configuration of the Electric Part.....	3-1
3.1.1 Main Board	3-1
3.1.2 Key Control Board	3-4
3.1.3 Scale Board	3-5
Chapter 4 Setup Mode.....	4-1
4.1 Startup.....	4-1
4.2 MACHINE NO. SETTING.....	4-3
4.2.1 MACHINE No. (BASIC)	4-3
4.2.2 MACHINE No. (IP ADDR.).....	4-4
4.2.3 MACHINE No. (PC COM).....	4-5
4.2.4 MACHINE No. (WiFi).....	4-6
4.2.5 MACHINE No. (GLOBAL SV.).....	4-7
4.2.6 MACHINE No. (SYNC.)	4-8
4.2.7 MACHINE No. (OUTSIDE PRINTER).....	4-9
4.3 PASSWORD	4-10
4.3.1 PASSWORD (OPERATE).....	4-10
4.4 KEY LOCK.....	4-11
4.4.1 KEY LOCK (DISPLAY KEY)	4-11
4.4.2 KEY LOCK (FUNCTION KEY).....	4-12
4.4.3 KEY LOCK (STROKE KEY).....	4-13
4.5 DATA STORAGE.....	4-14
4.5.1 DATA STORAGE (TOTAL ADD.).....	4-14
4.5.2 DATA STORAGE (TOTAL PROC.).....	4-15
4.5.3 DATA STORAGE (TRANSACTION)	4-16
4.5.4 DATA STORAGE (STORAGE).....	4-17
4.6 PLU OVERWRITE	4-18
4.7 PLU INITIAL DATA.....	4-19
4.7.1 PLU INITIAL DATA (SALE1)	4-19
4.7.2 PLU INITIAL DATA (MSG.)	4-20
4.7.3 PLU INITIAL DATA (IMAGE).....	4-21
4.7.4 PLU INITIAL DATA (PRINT).....	4-22
4.7.5 PLU INITIAL DATA (DATE)	4-23
4.7.6 PLU INITIAL DATA (CODE)	4-24
4.7.7 PLU INITIAL DATA (WRAP).....	4-25
4.8 PLU UPDATE	4-26
4.9 LABEL COMB	4-27
4.9.1 LABEL COMB. (BASIC)	4-28
4.9.2 LABEL COMB. (LABEL).....	4-29
4.9.3 LABEL COMB. (UPPER FIX).....	4-31
4.9.4 LABEL COMB. / DETAIL.....	4-32
4.10 LABEL FORMAT	4-33
4.10.1 LABEL FORMAT / PRINT CONTROL.....	4-34
4.10.2 LABEL FORMAT / DETAIL (BASIC).....	4-35
4.10.3 LABEL FORMAT / DETAIL (UNIT)	4-37
4.10.4 LABEL FORMAT / DETAIL (PREVIEW).....	4-39
4.11 BARCODE	4-40
4.11.1 BARCODE (POS FLAG).....	4-40
4.11.2 BARCODE (POS CODE).....	4-41
4.11.3 BARCODE (ITEM CODE).....	4-42
4.12 CUSTOM BARCODE.....	4-43

4.12.1	CUSTOM BARCODE (BASIC)	4-44
4.12.2	CUSTOM BARCODE (PREVIEW).....	4-46
4.13	MENU TITLE	4-47
4.13.1	MENU TITLE (OPERATE)	4-47
4.14	OPERATION SETTING	4-48
4.14.1	OPERATION SETTING (CALL1).....	4-48
4.14.2	OPERATION SETTING (CALL2).....	4-49
4.14.3	OPERATION SETTING (PROD.).....	4-50
4.14.4	OPERATION SETTING (PRINT.).....	4-51
4.15	ERROR PROCESS.....	4-52
4.15.1	ERROR PROCESS (ISSUE).....	4-52
4.15.2	ERROR PROCESS (CALL).....	4-53
4.15.3	ERROR PROCESS (COMMON).....	4-54
4.16	ERROR LOG.....	4-55
4.16.1	ERROR LOG (DISPLAY).....	4-55
4.17	TRACE.....	4-56
4.18	DUAL CURRENCY	4-57
4.19	PRICE ROUNDING.....	4-58
4.20	FREQUENT SHOPPER.....	4-59
4.21	STANDBY MODE	4-60
4.22	COUNTRY.....	4-61
4.22.1	COUNTRY / DETAIL (CURRENCY)	4-62
4.22.2	COUNTRY / DETAIL (WEIGHT)	4-63
4.22.3	COUNTRY / DETAIL (DATE)	4-64
4.23	FILE SAVE /LOAD.....	4-65
4.23.1	FILE SAVE/LOAD (USB>SCALE)	4-65
4.23.2	FILE SAVE/LOAD (SCALE>USB)	4-67
4.23.3	FILE SAVE/LOAD (USB DATA DEL.).....	4-69
4.23.4	FILE SAVE/LOAD (SCALE INIT.).....	4-71
4.23.5	FILE SAVE/LOAD / DETAIL.....	4-72
Chapter 5	Adjust Mode	5-1
5.1	Startup.....	5-1
5.2	DATE TIME	5-3
5.3	TOUCH SCREEN.....	5-5
5.4	DISPLAY CHECK.....	5-6
5.5	SOUND	5-7
5.6	KEY CHECK	5-8
5.7	FIRMWARE DETAILS	5-9
5.8	MEMORY CLEAR.....	5-10
5.9	PRINTER.....	5-12
5.9.1	PRINTER (HEAD).....	5-12
5.9.2	PRINTER (PEEL SENSOR)	5-14
5.9.3	PRINTER (LABEL TYPE)	5-15
5.9.4	PRINTER (LABEL FEED).....	5-16
5.10	CALIBRATION.....	5-18
5.10.1	Procedure for adjusting scale(span)	5-19
5.11	MACHINE TYPE	5-20
5.11.1	MACHINE TYPE / DETAIL.....	5-21
5.12	DOWNLOAD	5-23
5.12.1	DOWNLOAD (MAIN)	5-23

5.12.2	DOWNLOAD (SUB APP.)	5-24
5.12.3	DOWNLOAD (SUB BOOT).....	5-25
5.13	OPTION CHECK.....	5-26
5.13.1	OPTION CHECK (SCANNER)	5-26
5.13.2	OPTION CHECK(USB).....	5-27
5.13.3	OPTION CHECK (DEVICE).....	5-28
5.14	DISPLAY CAPTURE	5-29
5.15	GRAVITY	5-30
Chapter 6	Trouble shooting.....	6-1
6.1	Error Message	6-1
6.2	Error Codes.....	6-2
6.2.1	System-related Error (No. 100s).....	6-2
6.2.2	Memory-related Error (No. 200s).....	6-13
6.2.3	Precheck-related Error (No. 300s).....	6-43
6.2.4	Printer-related Error (No. 700s to 800s).....	6-60
6.2.5	Scale-related Error (No. 1600s).....	6-70
6.2.6	Dialog Selection-related Error (No. 1800s, 4200s).....	6-74
Chapter 7	Appendix	7-1
7.1	Operation Sequence	7-1
7.1.1	At Start-up	7-1
7.1.2	When Issuing Labels	7-4
7.2	Wiring Diagrams.....	7-9

Chapter 1 Overview

1.1 Specifications

Items	Descriptions
Product name	IP-AI
Product classification	Weight price labeler
Use conditions	Temperature 0°C to 40°C, Humidity 20% to 85% (Non condensing) *The printable environment depends on the label specifications.
Installation status	Installation on an IP stand or a work table
Option	Name file stand Numerical keypad cover I2NET expansion board Wireless LAN (simultaneously supporting WM-AI) Protective sheet for panel SD card theft prevention cover ◇The following items are reused from IP-UNI. Wand scanner (DENSO HC56, GT-10B) Wand scanner stand / holder Inside winding RS232 expansion board *No PP interlocking.
External dimensions	Main unit 302(W) × 370(D) × 673(H) max. Weighing unit 300(W) × 270(D) × 88(H) max.
Weight	Main unit 19kg max. Weighing unit 6kg max.
Power supply	100 V ~ 240 V AC ±10% 50/60Hz *No service outlet
Exterior	Printer body Grain finish (to prevent label from sticking) Bottom part Metal coating
Drip resistance	Simple drip-proof structure (Water should not come into contact with electric components when the vertical drop test is performed.)
Mechanism	Angle adjustment type (Angle: Front side -5° to back side 40°) *Based on the upright position of the display part
Display	12.1-inch TFT color LCD with LED backlight SVGA (800×600)
Used keys	Resistance film type analog touch panel Keystroke (24 keys max.)
Key dimensions	Touch panel: approx. 248mm × 187mm (effective area) Keystroke Single: approx. 18 × 18 Double: approx. 18 × 37
Printing method	Direct thermal method
Thermal head	3-inch (960 dots and 12 dots/mm) thermal head
Printing speed	150 mm / sec. max. (Target value) *The printing speed can be switched depending on the label sensitivity.
Effective printing size	Width 78mm
Label replacing method	Front-loading

Items	Descriptions
Label roll diameter	Paper pipe inner diameter ϕ 76mm Maximum outer diameter ϕ 224mm
Label storage capacity	5000 labels (42mm, 2.5mm gap)
Label size	Label width 20mm to 80mm Label length 20mm to 150mm *Label backing paper width 82mm max.
Issuing method	Switchable between label peeling-off and continuous label printing. Back-feed issue possible.
Label winding direction	Outside winding
Label shape	Circular and oval labels can be handled.
Barcode (Symbol)	1-dimensional: JAN, ITF, CODE128, EAN128 2-dimensional: QR (1:1 feeding, Label type: Ricoh 150LA-1) Vertical bar only (The ladder bar is not supported.)
Recommended label	OSAKA SELING V8NS Ricoh 150LA-1
Printing accuracy	Width direction ± 0.5 mm Print start position: ± 0.5 mm Print length :Less than 60mm of label height: ± 1 mm or less 60mm or above of label height: ± 2 mm or less
Weighing type	<ul style="list-style-type: none"> •6000g: 0 to 3000g/1g, 3000 to 6000g/2g, Multiple interval •6kg: 0 to 3kg/0.001kg, 3 to 6kg/0.002kg, Multiple interval •15kg: 0 to 15kg/0.005kg, Single interval •15kg: 0 to 6kg/0.002kg, 6 to 15kg/0.005kg, Multiple interval •30lb: 0 to 30lb/0.01lb, Single interval •30lb: 0 to 15lb/0.005lb, 15 to 30lb/0.01lb, Multiple interval •30kg(1/6000): 0 to 15kg/g, Single interval •60lb(1/6000): 0 to 60lb/0.01lb, Single interval
Weighing accuracy	1/3000 (Accuracy class: Class III) 1/6000 (Accuracy class: Class III)
OS specification	Linux
Standard Input/output	Ethernet (10/100base-TX) :1 ch RS-232C :4 ch (1ch is used only for scanner.) SDCard :1 ch
UDF support	UD font mounted MORISAWA UD Shin Go (Style: M, DB, B Character collection: Adobe-Japan1-4)
Power saving mode	The machine shifts to a power saving mode when no operation is performed for a fixed time.
Specification type	Standard specifications (Store offline)
Higher-level communication	Corresponding to SLP-5.

Items	Descriptions
Lifetime	Duration of service: 5 years Lifetime: 233.6km Assumption: 3000 labels/day, 350 days/year, label height 42mm, label gap 2.5mm, 12 hours/day 4,200 hours/year, 21,000 hours for 5 years $3,000 \text{ labels} \times 350 \text{ days} = 1,050,000 \text{ labels/year}$ $1,050,000 \text{ labels} \times 5 \text{ years} = 5,250,000 \text{ labels}$ $5,250,000 \text{ labels} \times (42\text{mm} + 2.5\text{mm}) = 2,336,000 \text{ mm}$
Consumable parts	Thermal head, print roller
Cleaning	Parts to be cleaned (A cleaning manual and a cleaning kit are provided.) Thermal head Label path
Safety	Ishida product safety standards Signal word standards CE marking · UL · cUL
Standards	Compliant with Ishida product standards and Ishida sanitation standards Japanese Measurement Act NTEP (USA) · OIML(Europe)

1.2 Features

The display has been changed to 12.1 inches and the thermal head to 12 dots/mm based on IP-UNI.

The larger display allows elderly operators to easily see and contributes to prevention of operation mistakes.

High-accuracy printing contributes to creating stores that are safe and secure for consumers.



- The machine has a built-in wireless LAN and a built-in M2M board (optional), which make it easier to upgrade the remote maintenance program.

1.3 Name of Each Part

Front view



NOTE:

The label cassette is called the label printer in the operation manual. The label cassette of the machine is not replaceable.

Rear view

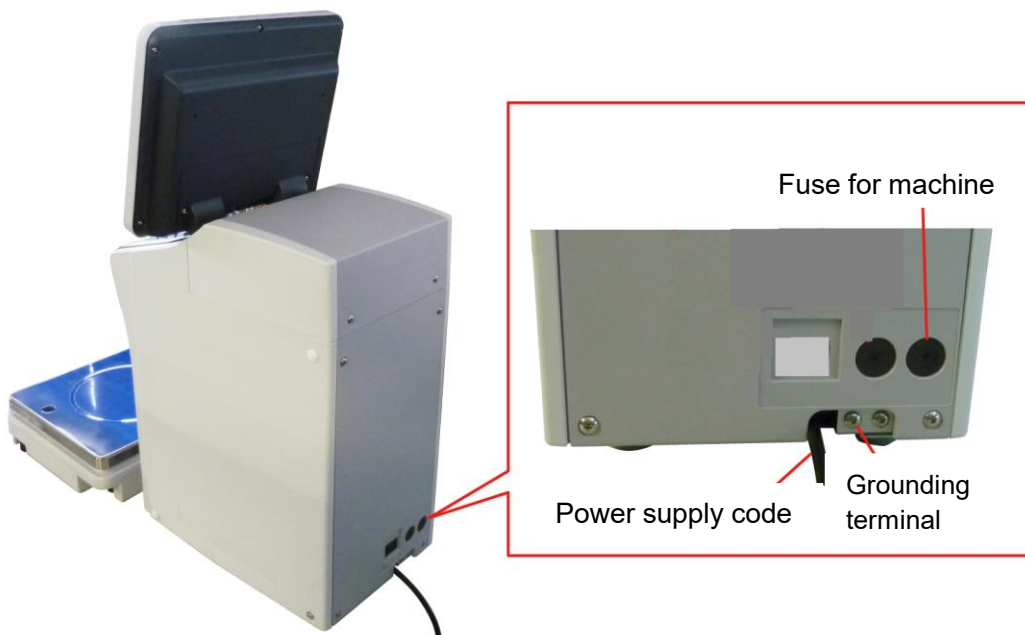

1.4 Dimensions

The following drawing shows the dimensions. Make sure to secure a carry-in route and space required for setup and maintenance.

DIMENSIONS 60LB BASE			
A	15.4in (390mm)	D	12.0in (305mm)
B	10.6in (270mm)	E	7.9in (200mm)
C	4.9in (125mm)		

DIMENSIONS 30 LB BASE			
P	9.9in (252mm)	R	3.8in (95mm)
Q	16.9in (430mm)		

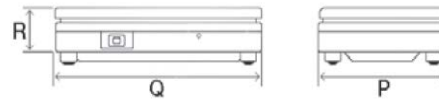
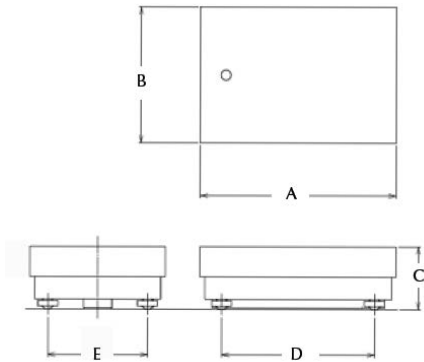

DIMENSIONS CONTROLLER UNIT			
A	11.8in (300mm)	D	13.2in (335mm)
B	9.1in (230mm)	E	18.7in (474mm)
C	14.5in (368mm)	F	26.4in (670mm)

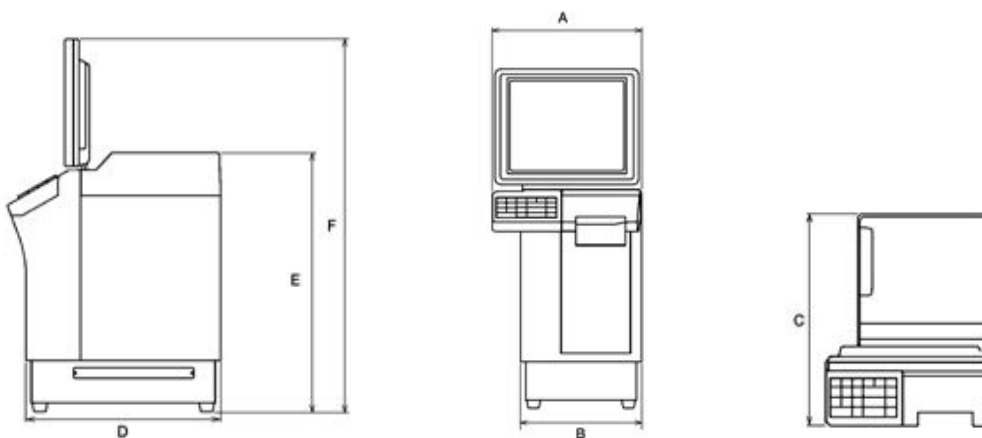

1.5 Items Required for Installation

No.	Description	Check
1	Balance weight (6kg, equivalent to M1 class)	<input type="checkbox"/>
2	USB memory (that stores data of the user)	<input type="checkbox"/>
3	Labels	<input type="checkbox"/>
4	Phillips head screwdriver	<input type="checkbox"/>

1.6 Installation Space

- Secure sufficient working space on the left and right side of the machine.

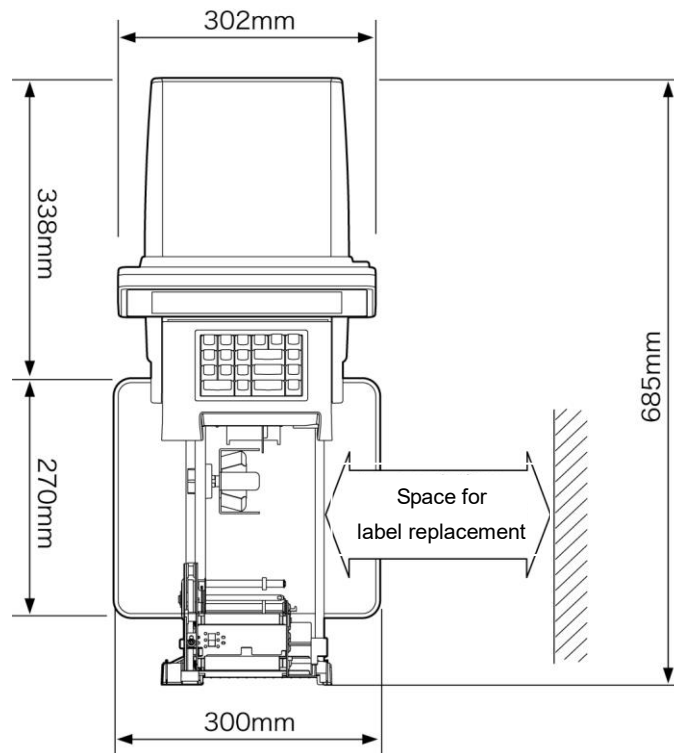

1.7 Power Supply

- This machine requires single-phase 100VAC power supply with 4A capacity. The shape and rating of the power plug are illustrated. Prepare an outlet which conforms to the standards.
- Noise or a voltage drop in the power supply will cause a malfunction. Make sure to install a dedicated power supply.
- Perform class D grounding (former class 3 grounding) or higher to prevent electric shocks and malfunctions.
- Noise or a voltage drop in the power supply will cause a malfunction. Make sure to install a dedicated power supply.

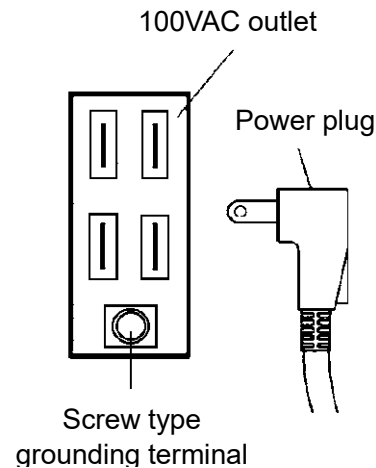

CAUTION

Select a breaker for the building which achieves protection coordination. This machine uses a motor to perform switching operation, which causes high-frequency components and leakage current to increase compared to general commercial power supply. As there is harmonic leakage current, always install a breaker corresponding to harmonic current.

DANGER!

All electric work must be performed by a qualified electrical engineer.

WARNING

To prevent accidents due to electric shock, always ground the machine.

1.8 Carry-in and Installation

1.8.1 Installation Procedure Check Sheet

Step	Description	Check
1	Carry in IP-AI. (Total weight 25kg) • Confirm the installation place.	<input type="checkbox"/>
2	Connect the cable of the weighing unit to the main unit.	<input type="checkbox"/>
3	* Make an adjustment so that the bubble is located at the center of the level gauge.	<input type="checkbox"/>
4	When connecting the PP-AI, connect the provided grounding terminal to the PP-AI. When connecting other machines, connect them according to the following: Other machine of master-slave system..... LAN Optional printer (PP-AI) USB Journal printer..... RS-232C	<input type="checkbox"/>
5	• Connect the power plug to the single-phase 100VAC outlet.	<input type="checkbox"/>
6	• Set the labels. Refer to Chapter 1 "Label setting" in the operation manual.	<input type="checkbox"/>

**WARNING**

Be sure to pull out the power plug from the outlet when connecting machines.

1.9 Setup

1.9.1 Requirements for Setup

- USB flash memory (that stores data of the user)
- Balance weight (6kg, equivalent to M1 class)

1.9.2 Setup Procedure

- Perform a setup operation in the [Setup Mode] and the [Adjust Mode] on the maintenance screen whose authority is controlled with login.



Refer to Chapter 4 Setup Mode and Chapter 5 Adjust Mode for each operation.

- The following three adjustments can be made in the Setup Mode on the normal screen.

1) Items required for adjusting

- Memory initialization (Adjust Mode)
- Printer (Label adjustment) (Adjust Mode)
- Production processing (Setup Mode)
- Issuing pattern (Setup Mode)
- Formatting (Setup Mode)
- Error processing (Setup Mode)
- Total amount (Setup Mode)
- POS (Setup Mode)

2) Downloading data of the user

- To use the USB flash memory that stores data of the user, select **[FILE SAVE/LOAD]** in the Setup Mode for maintenance and download to this machine on the **[USB > SCALE]** tab page.

MASTER NAME	NUMBER
PLU	4
STORE	2
FIX PRICE SYMBOL	20
PRESET KEY (LCD)	65
FORMAT	2
LABEL	7
CASSETTE	25

FILES SAVED ON USB

USB > SCALE | SCALE > USB | USB DATA DEL. | SCALE INIT.

File input/output screen

To logout (return to the first screen), do not enter any value or enter "0", and press the [Login] button.

Recommended product (USB memory stick)
Product No.: 160906 Product Name: Hagiwara, USB, 1G
NOTE: Please note that the recommended USB memory is subject to change without notice.

3) Items required for checking (Setup Mode)

- Password
- Item data auto update
- Key lock
- Item initial value settings
- Individual identification
- File input/output
- Function key
- Total addition
- Pack date/Expiry date
- Function key
- Machine/department number (Set this according to the specifications.)

1.9.3 Operation Checks

■ Weighing check

Place a balance weight (6 kg, equivalent to M1 class) on the weighing platter and confirm that the displayed weight is within $6,000 \text{ g} \pm 1 \text{ scale unit (2 g)}$.

■ Four-corner check

Place a weight (approximately 3kg but not heavier) on the center and four corners of the weighing platter, and confirm that the difference between the center and four corners is within $\pm 1 \text{ scale unit (1 kg)}$.

■ Label printing check

Check the print on labels that are used by the users.

(Confirm that the following data are correct: date, weight, calculation processing of weight and unit price and price display.)

1.9.4 Operation Explanation

Explain the operation method and precautions to the user based on the operation manual. Confirm that the user fully understands.

1.9.5 Issuing a Warranty

Fill in necessary items in the warranty and give it to the user.

Chapter 2 Mechanical Adjustment

2.1 Removing Case Covers

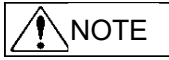

Remove the case covers in the following order: case body (top), case bodies (right & left), and case bodies (rear & scale cable).

2.1.1 Case Body (Top)

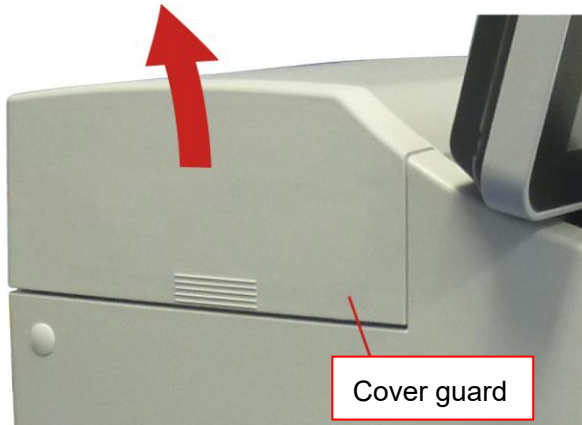

(1) Remove the cover guard by sliding it in the direction of the arrow.

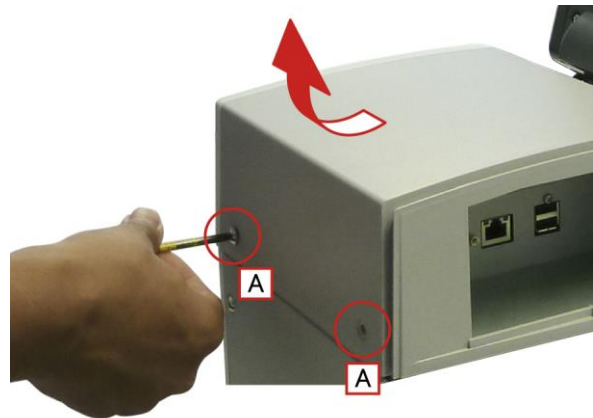

(2) Remove the two screws A, and remove the case body (top) in the direction of the arrow.

2.1.2 Case Body (Left Side)

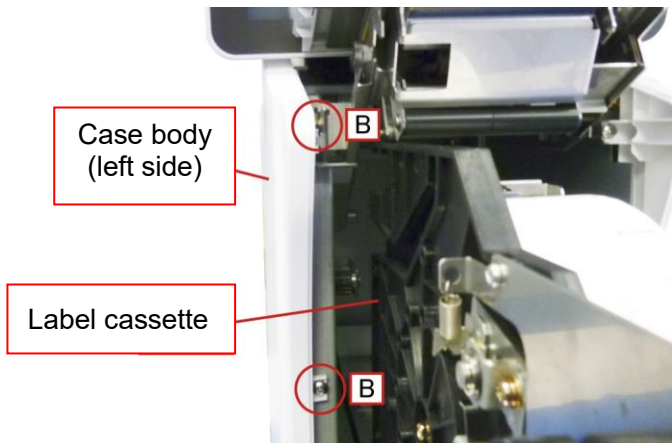

(3) Pull out the label cassette and loosen the two screws B.

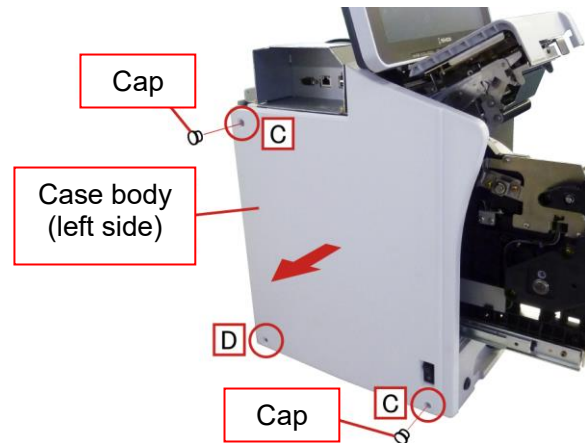

(4) Remove the two caps, the two screws C, and the stepped screw D, and then remove the case body (left side).

2.1.3 Case Body (Right Side)

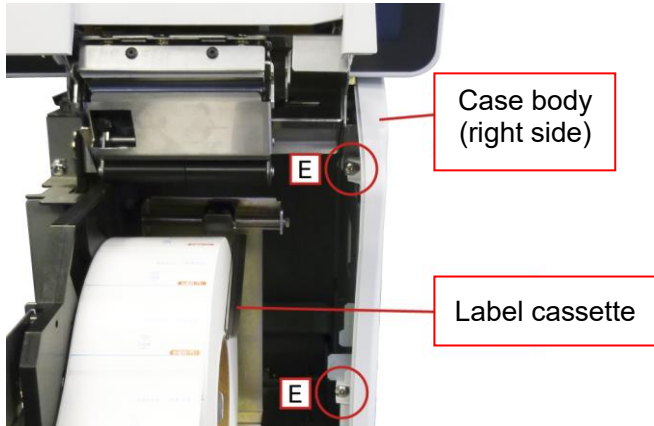

(5) After pulling out the label cassette, loosen the two screws E.

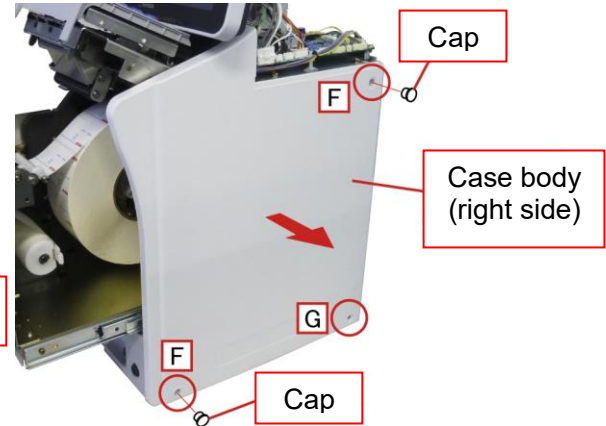

(6) Remove two caps, two screws F and the stepped screw G, and then remove the case body (right side).

2.1.4 Case Body (Rear)

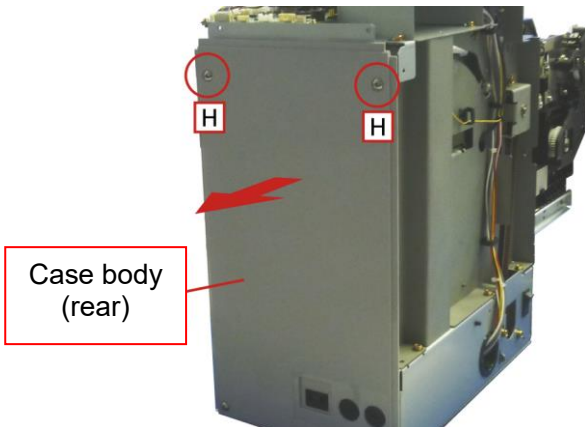

(7) Remove the two screws H, and then remove the case body (rear).

2.1.5 Case Body (Scale Cable)

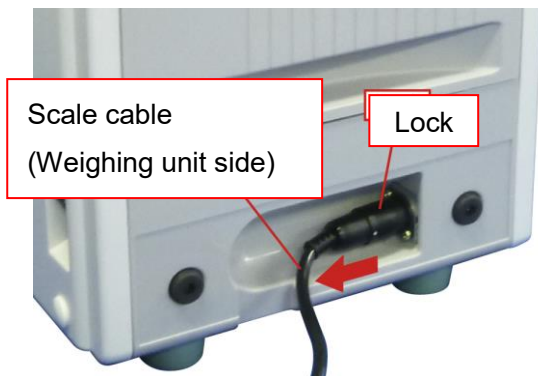

(1) Pull out the scale cable (weighing unit side) in the direction of the arrow while holding the lock.

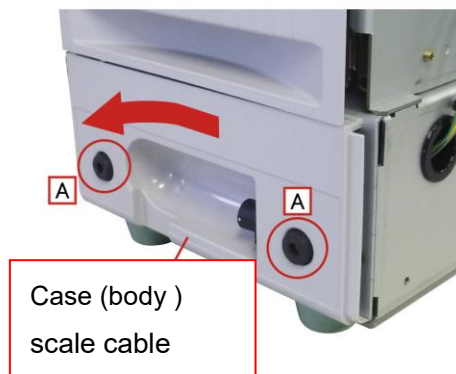

(2) Remove two screws A (with rubber feet), and remove the scale cable for the case (body) in the direction of the arrow.

2.2 Replacing Parts

2.2.1 Replacing the Thermal Head

- (1) Pull out the label cassette.



- (2) Remove the two hexagonal head screws A.

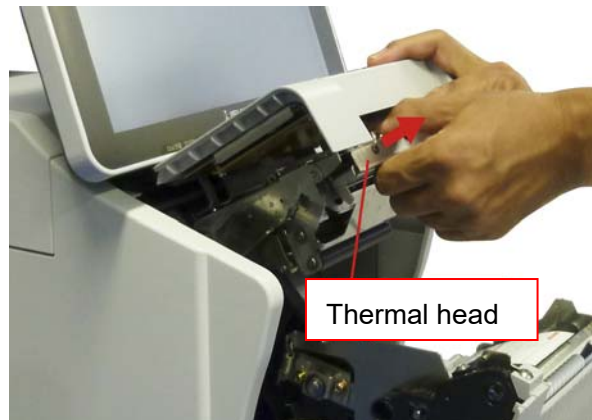

- (3) Pull out the thermal head forward.

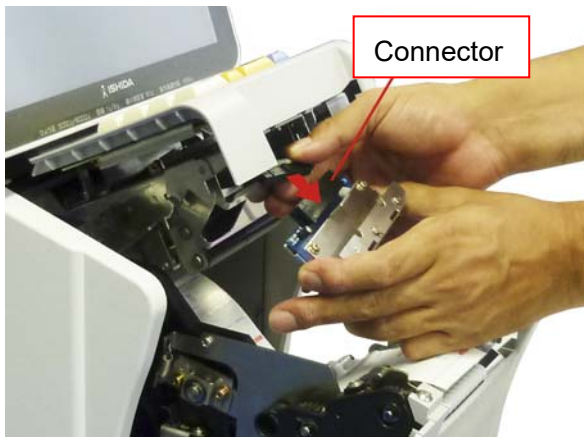

- (4) Pull out the connector for the thermal head.

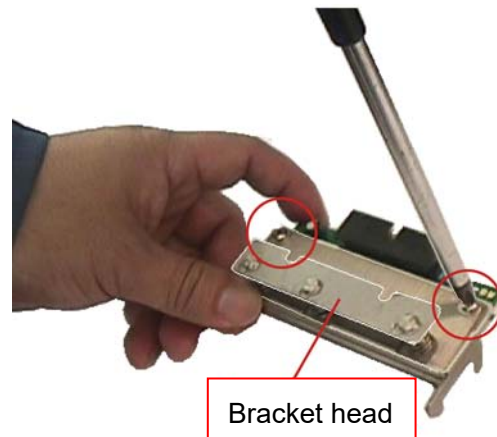

- (5) Remove the two screws and remove the bracket head.

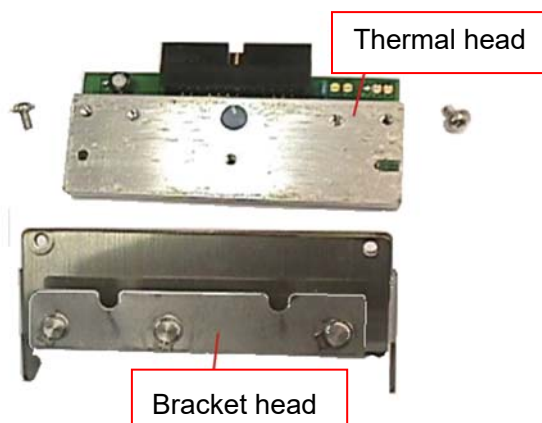

- (7) Mount the thermal head in the reverse order of the removal procedure. Always check the print after mounting.

(Refer to pages 2-4 to 2-5.)

- (6) Replace the thermal head, and mount the bracket head.

*Mount the thermal head and the bracket head in parallel.

2.2.2 Adjusting the Thermal Head Position

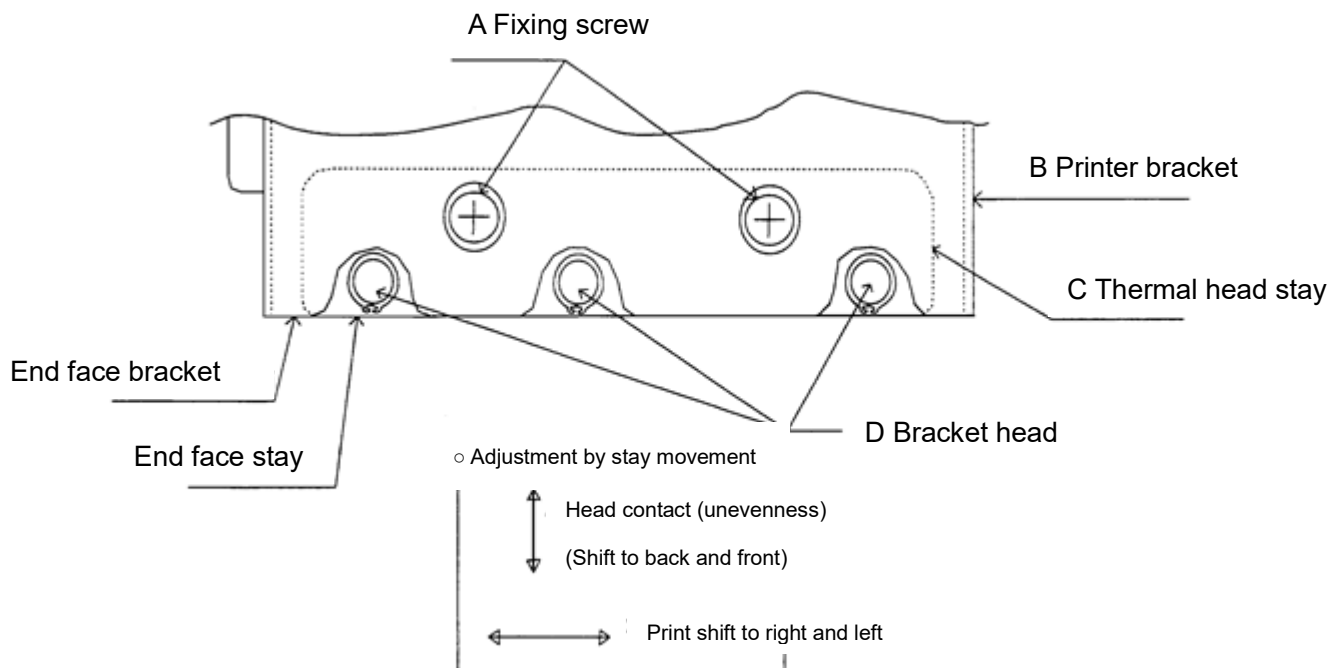

If the print density is uneven or the print is light when test labels are issued, the thermal head may not be positioned properly. In this case, adjust the position of the thermal head.

(1) Preparation

Confirm that the label cassette is in a proper state.

- a. Adjust the gap between the label holder guide lever and the label width (paper pipe) from 0.2 mm to 0.5 mm.
- b. Adjust the gap between the label guide and the backing paper from 0.1 mm to 0.4 mm.

(2) Load the label cassette into the main unit properly.

(3) Turn ON the power supply and start up the test mode. Then, select the print adjustment, set the head resistance, and set the print density to 1. (Refer to the chapter that describes print adjustment in the test mode).

(4) Make label-related settings. (same as above)

(5) Press the [FEED] key several times and adjust the label position.

(6) Issue test labels. (Press [Checker] for label printing.) Press the [PRINT] key. Check the label from around the third printing to confirm that no print is shifted to the right or left and that the print density is even between the right and left sides.

(7) Make the following adjustments if there is any print that is shifted to the right or left or the print density is uneven between the right and left sides.

a. How to adjust the standard position

By referring to the figure above, loosen the fixing screws A, align the front end face of the printer bracket B with the front end face of the thermal head stay C, and temporarily tighten the fixing screws A. Then, adjust the position while issuing test labels.

b. When the entire print is light

The center line of the heat generation belt of the thermal head is not aligned with the center line of the print roller. By referring to the figure above, shift the fixing screws A to the back or front while checking the printing conditions and find the position that allows the darkest print density. Then, tighten the fixing screws A.

- c. When the print density differs between the right and left sides
 The thermal head on the side that has the lighter print is shifted to the back or front from the center line of the print roller.
 By referring to the figure, loosen the fixing screws A, and shift and adjust the fixing screws so that the left and right sides of the thermal head are parallel to the center line of the print roller when viewed from above (this means the center lines are aligned.)
- d. When the print position is shifted to the right or left
 Loosen the fixing screws A, shift the position of the thermal head to the opposite direction from the shifted one (left or right) while maintaining the parallelism described above, and secure the thermal head.

(8) Return to the original print density.

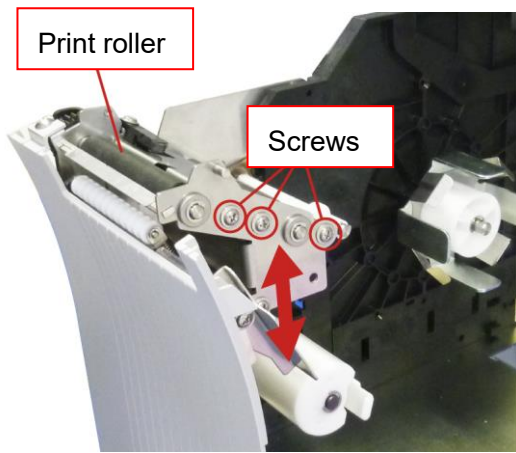

If the print density is still uneven after these adjustments have been made, loosen the three screws on the print roller side and adjust the tilt of the print roller.

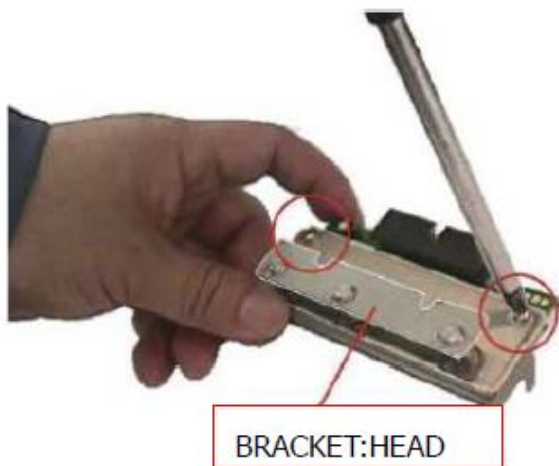

Loosening the two screws to fix the bracket head and thermal head can also adjust the position of the thermal head, which is adjustable while the parts are attached to the machine.

Basically, be sure to attach the thermal head and bracket head so that they are flush with each other.

2.2.3 Replacing the Print Roller

- (1) Pull out the label cassette.

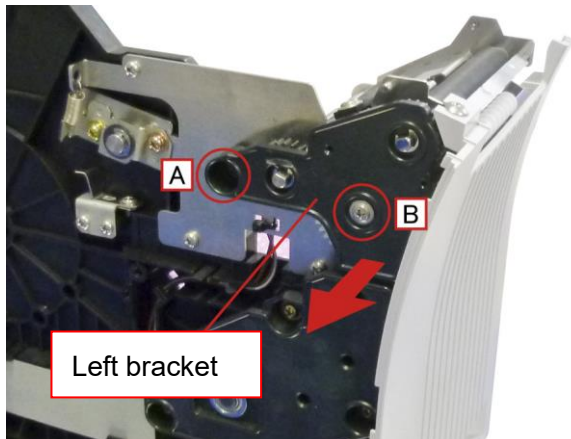

- (2) Remove the stepped screw A and the screw B and remove the left bracket.

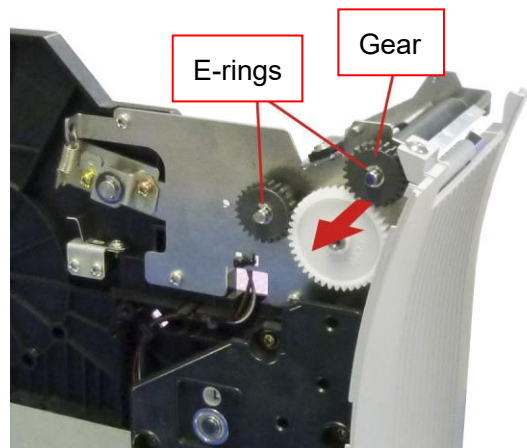

- (3) Remove the E-rings (from two points) and remove the gear.

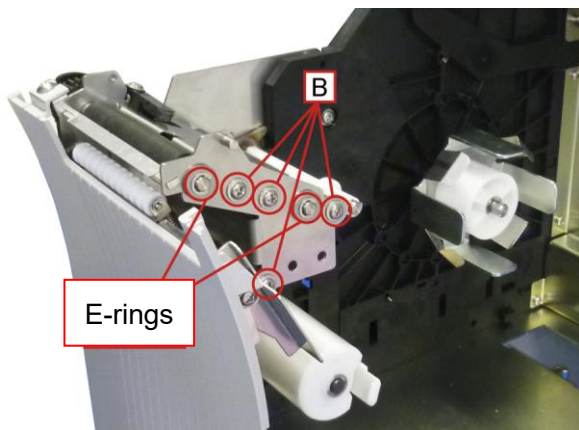

- (4) Remove the four screws B and the E-rings (from two points).

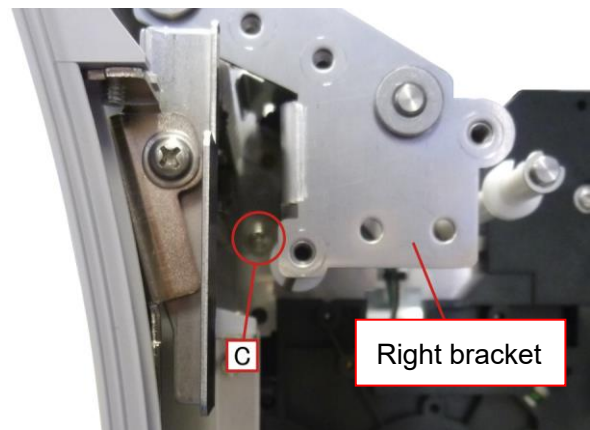

- (5) Remove the screw C from the back and remove the right bracket.

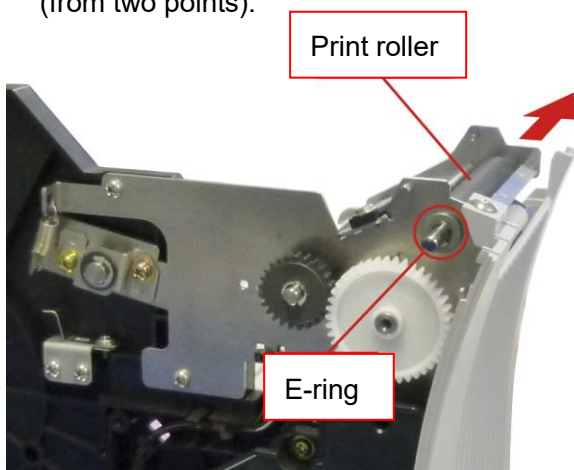

- (6) Remove the E-ring from the left side and remove the print roller.

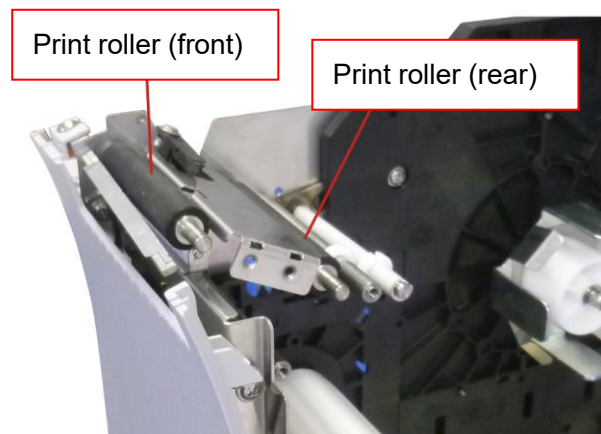

- (7) Remove the print roller (rear) by using the same procedure.

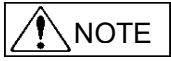
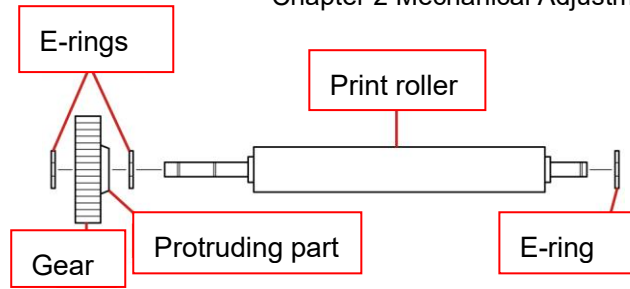
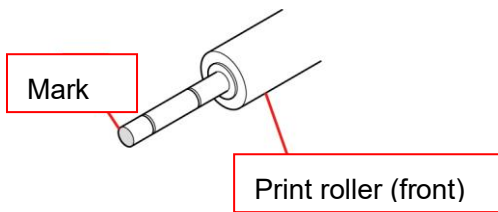

The diameters of the front and rear sides of the print roller are different. Make sure to replace it correctly.

*There is a mark on the print roller (front)

(8) After replacing the print roller, mount it in the reverse order of the removal procedure.

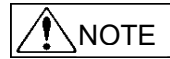

Mount the gear so that the protruding part faces inward.

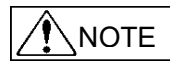

After mounting the print roller, always confirm that the print density is even in the same way as the thermal head.
(Refer to pages 2-4 and 2-5.)

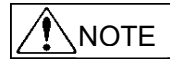

E-rings cannot be reused.
Replace with new ones.

2.2.4 Replacing the Peeling Sensor

- (1) Pull out the label cassette approximately 2 cm to 3 cm.

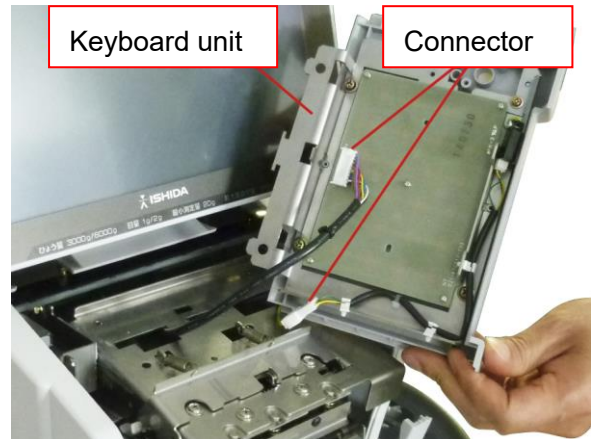
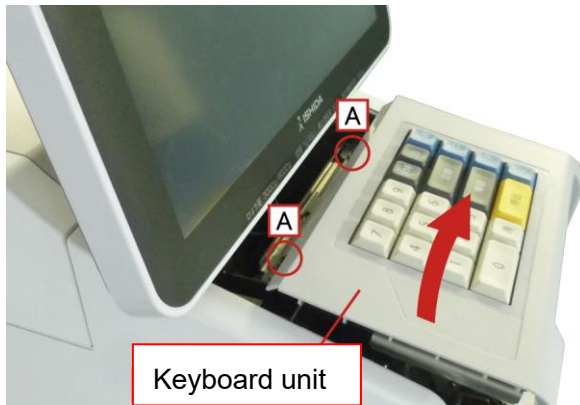

- (2) Remove the two screws A and open the keyboard unit. **CAUTION:** The "A" screws have small collars.

- (3) Remove the two connectors and remove the keyboard unit.

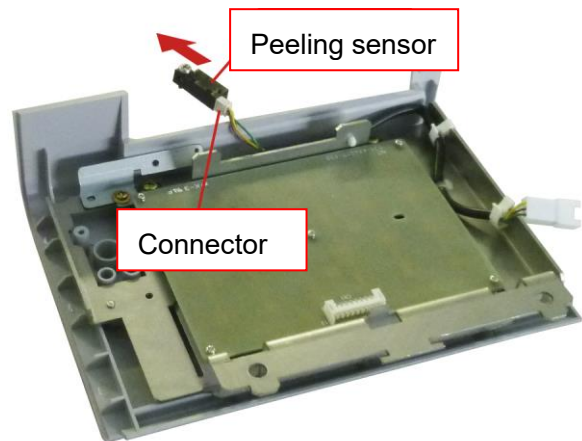
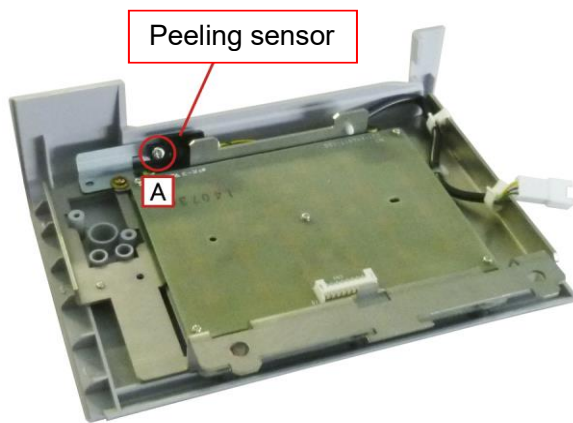

- (4) Remove the screw A that holds the peeling sensor.

- (5) Remove the connector and replace the peeling sensor. After the replacement, mount it in the reverse order of the removal procedure.

2.2.5 Replacing the Label Sensor

- (1) Pull out the label cassette.

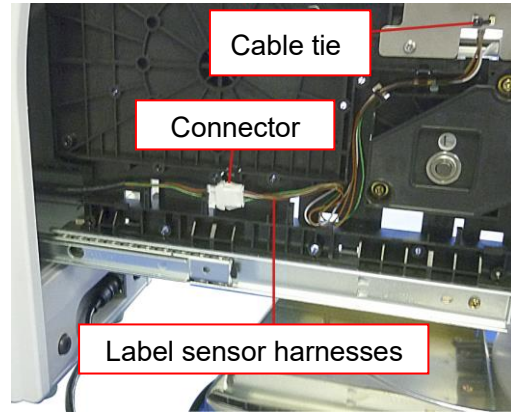
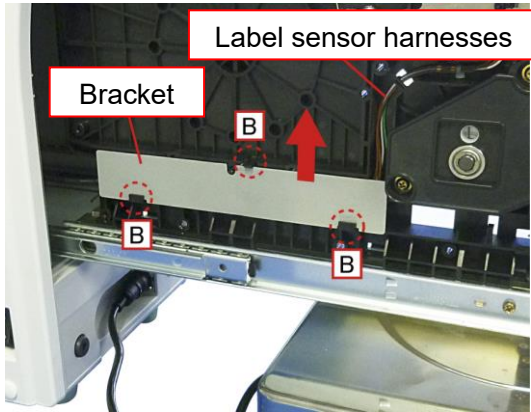

- (2) Remove the claws B (from three points) and remove the bracket that holds the label sensor harnesses.

- (3) Remove the connector for the label sensor harnesses and cut the cable tie.

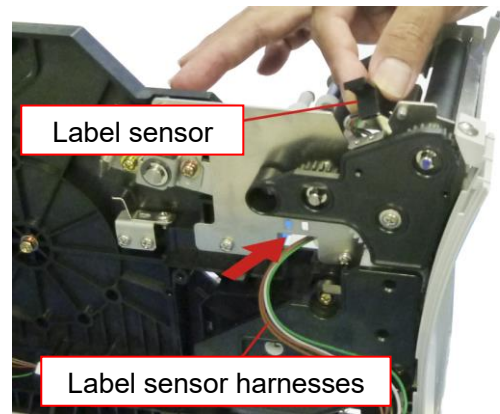
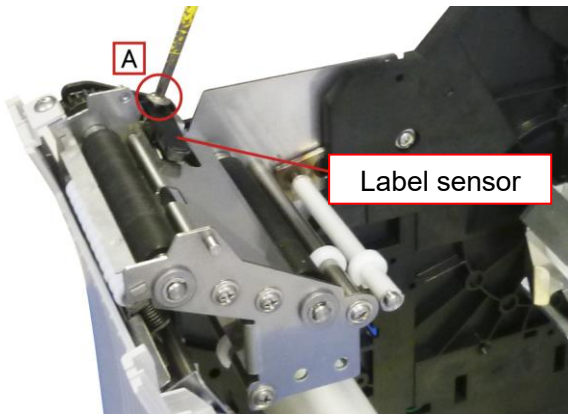

- (4) Remove the screw A that holds the label sensor.

- (5) Pull out the label sensor harnesses and replace the label sensor.

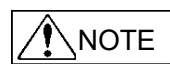
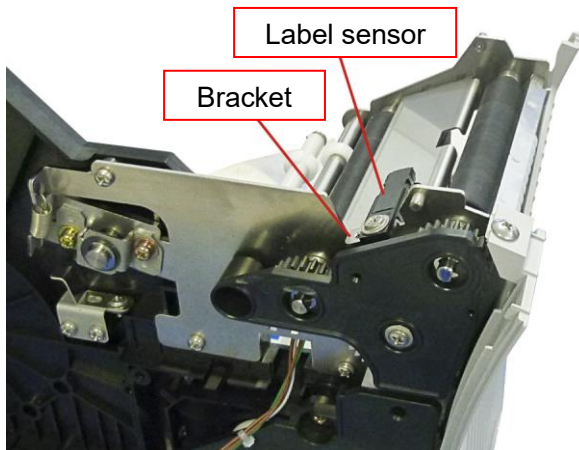

Mount the label sensor on the front side of the two bracket holes.

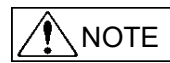

Replace the cable tie that was cut in step 3 with a new one.

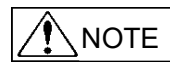

When the harnesses are held with the bracket described in step 2, mount the bracket so that the harnesses do not get caught.

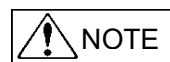

When wiring the label sensor harnesses, make sure that they do not interfere with the shaft of the platen roller.

- (6) After replacing the label sensor, mount it in the reverse order of the removal procedure.

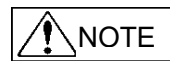

Confirm that the label sensor operates normally after replacement.

2.2.6 Replacing the Head Up Sensor

- (1) Remove the case body (top) and case body (left side). (Refer to page 2-1.)

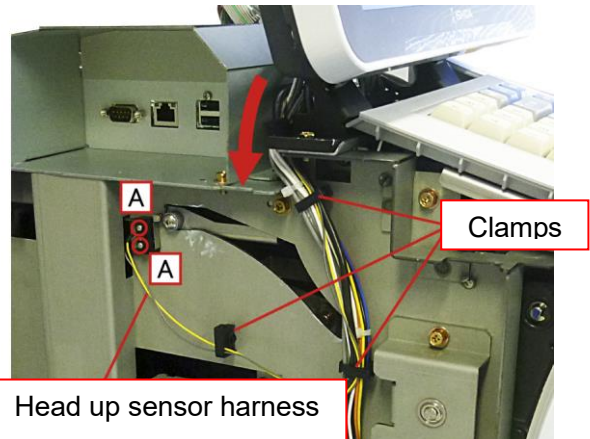
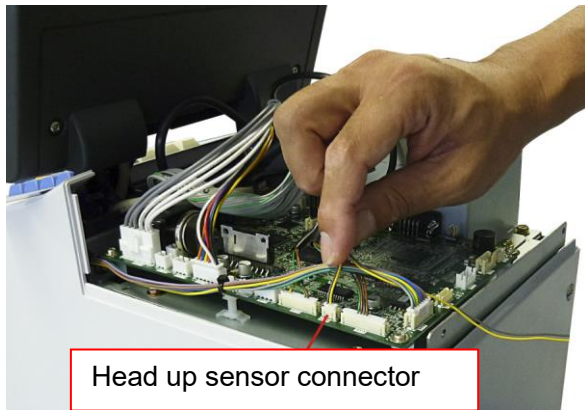

- (2) Remove the head up sensor connector for the main board. (3) Remove the two screws A and three clamps and replace the head up sensor.

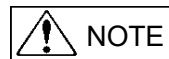
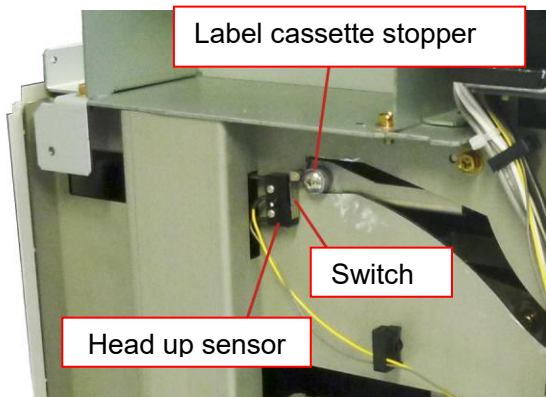

Mount the label sensor stopper so that it lightly comes into contact with the switch for the head up sensor. Make sure the label cassette stopper does not come into contact with the head up sensor.

- (4) After replacing the head up sensor, mount it in the reverse order of the removal procedure.

2.2.7 Replacing the Keyboard

- (1) Remove the keyboard unit by following the procedure to replace the peeling sensor. (Refer to page 2-8).

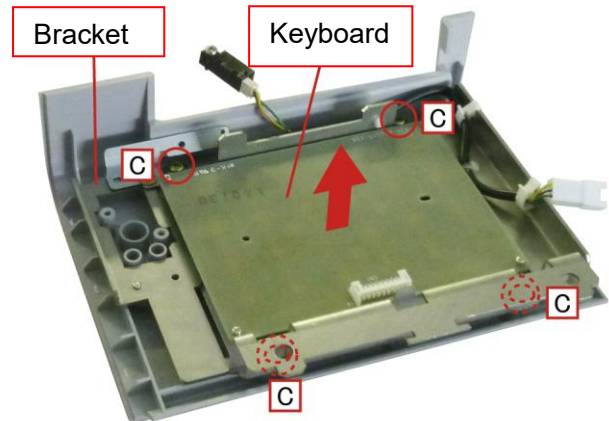
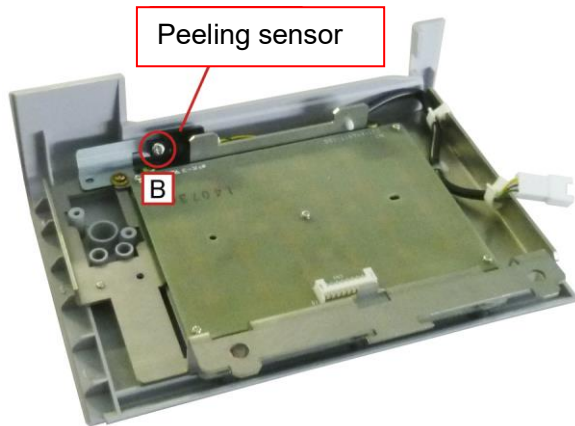

- (2) Remove the screw B and remove the peeling sensor.
- (3) Remove the four screws C, remove the keyboard together with the bracket and replace the keyboard.

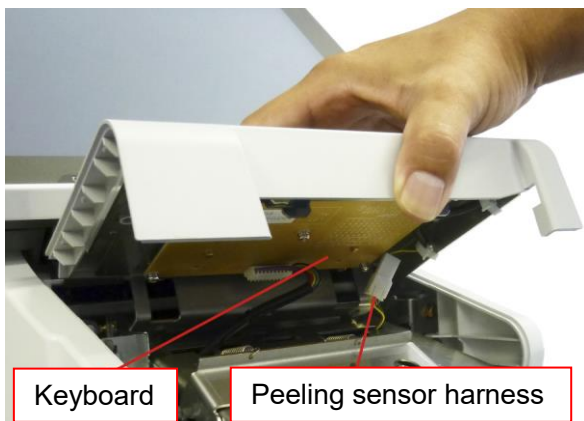

- (4) After replacing the keyboard, mount it in the reverse order of the removal procedure.

*If the peeling sensor harness gets caught, the keyboard cannot be mounted properly. Correctly place the harness next to the keyboard.

2.2.8 Replacing the Main Board

(1) Remove the case body (top). (Refer to page 2-1.)

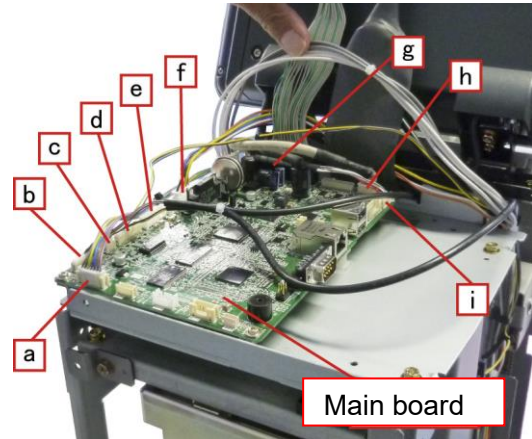
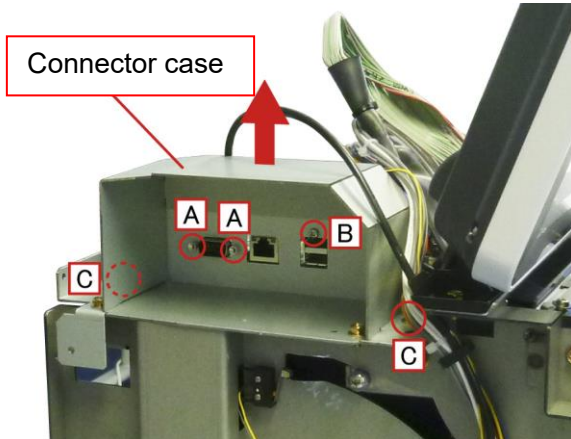

(2) Remove the two hexagonal head screws A, one screw B, two screws C, and then remove the connector case.

(3) Remove the connectors a to i from the nine points.

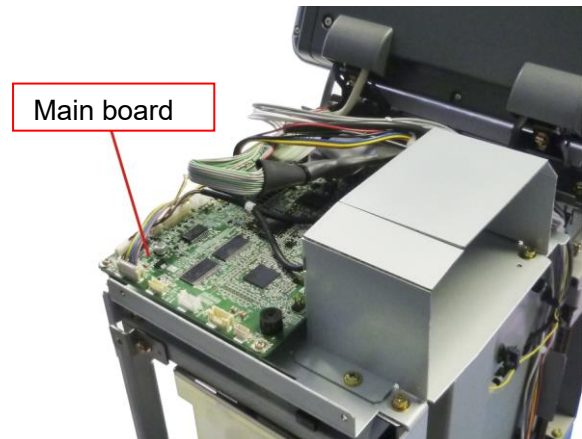
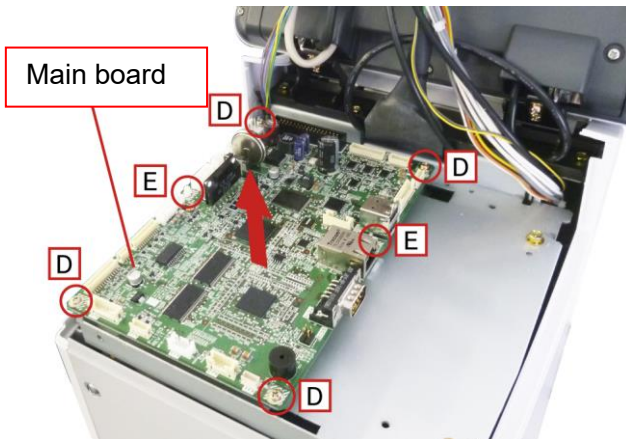

(4) Remove the four screws D and the two board holders E, remove the main board in the direction of the arrow and then replace it.

(5) After replacing the main board, mount it in the reverse order of the removal procedure. Bundle the harnesses as shown in the figure.

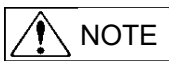

NOTE

Bundle the harnesses so that they do not get caught.

(6) Turn on the battery switch.

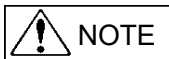

NOTE

The main board is in the initial status. Therefore, it must be set up.

(7) After program loading, follow the setup procedure specified in Chapter 1-9. (Refer to pages 1-11 to 1-13.)

2.2.9 Replacing the Power Supply Board

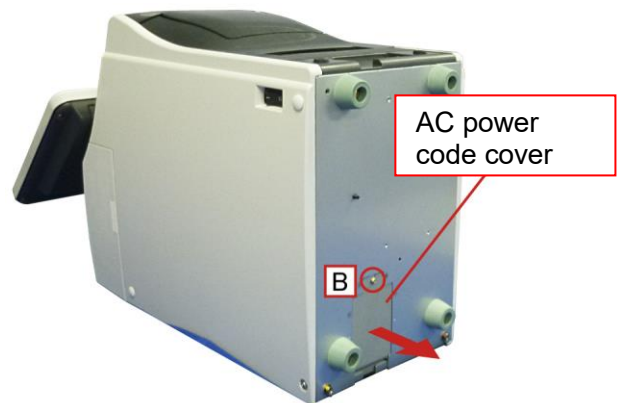
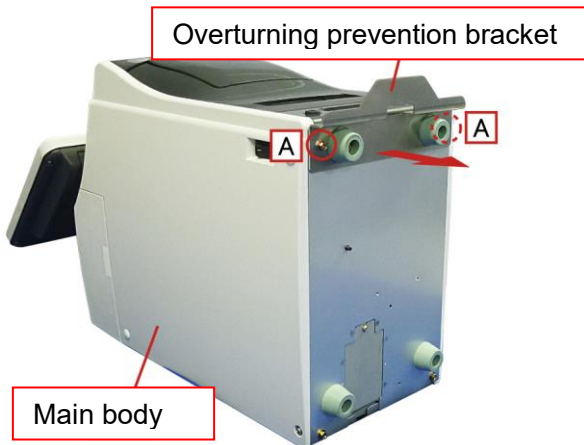

- (1) Overturn the main unit as shown in the figure. (2) Remove the screw B and then remove the AC power code cover.

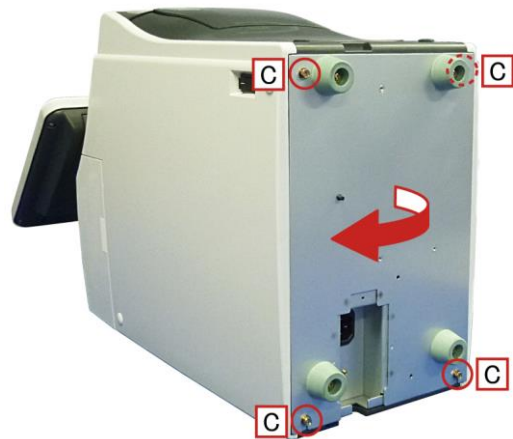
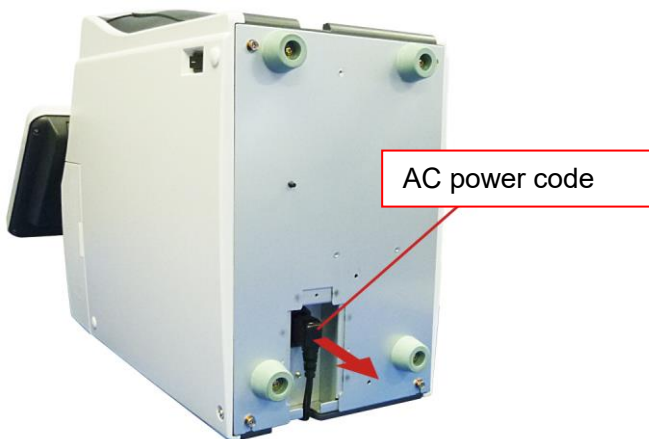

- (3) Pull out the AC power cord and remove. (4) Remove the four screws C and open the bottom plate in the direction of the arrow.

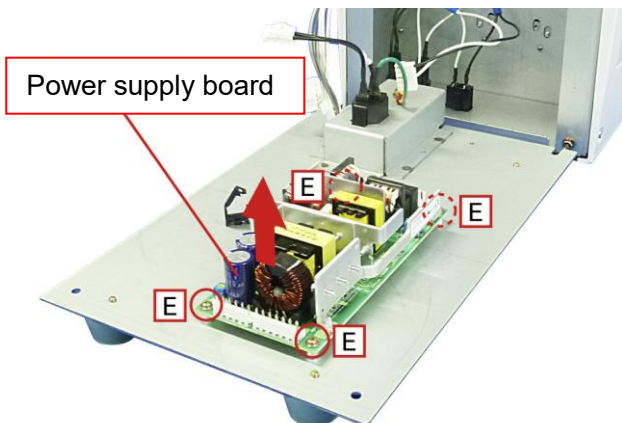
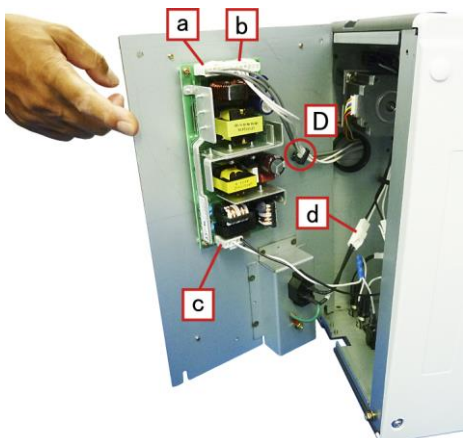

- (5) Remove the connectors a to d. (6) Open the harness holder D and then open the bottom plate. (7) Remove the four screws E and replace the power supply board. (8) After the replacement, mount it in the reverse order of the removal procedure.

2.2.10 Replacing the Motor

- (1) Remove the case body (top) and case body (left).
- (2) Overturn the main unit by referring to the procedure to replace the power supply board, and open the bottom plate. (Refer to page 2-13.)

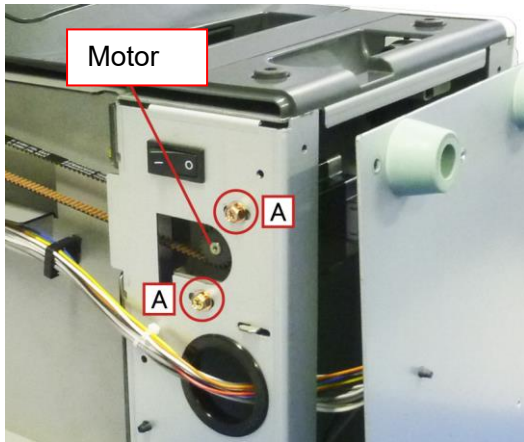

- (3) Remove the two screws A.

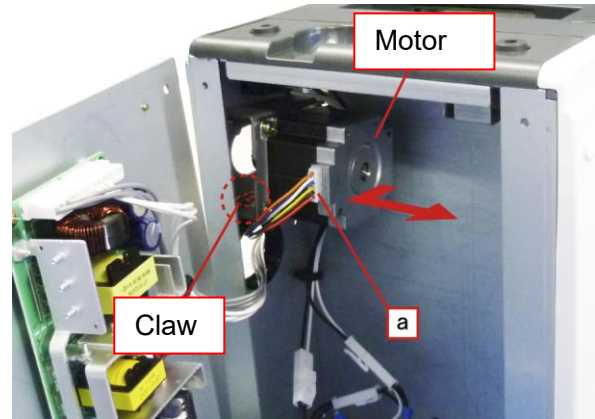

- (4) Remove the connector a and then remove the motor in the direction of the arrow while removing the claw.

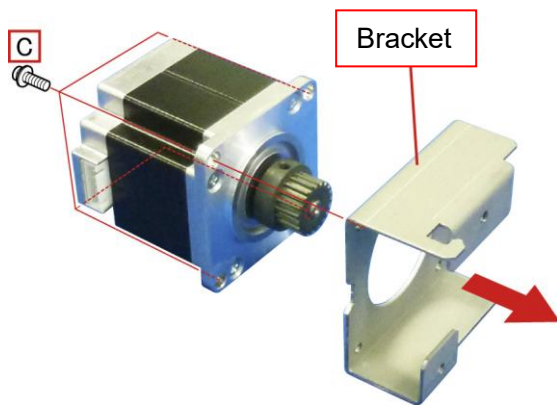

- (5) Remove the four screws C and then remove the bracket.

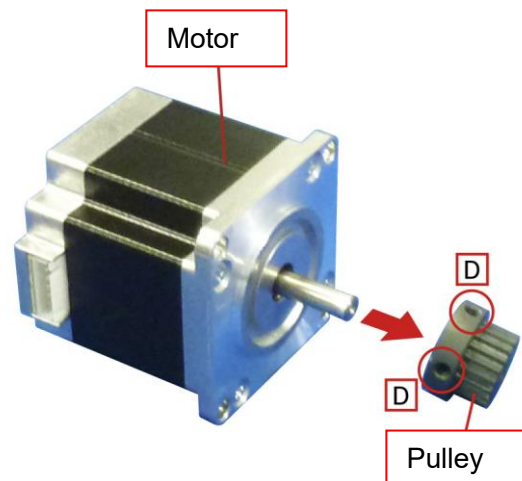

- (6) Loosen the two screws D with a hexagon wrench, and remove the pulley. Replace the motor in this state.

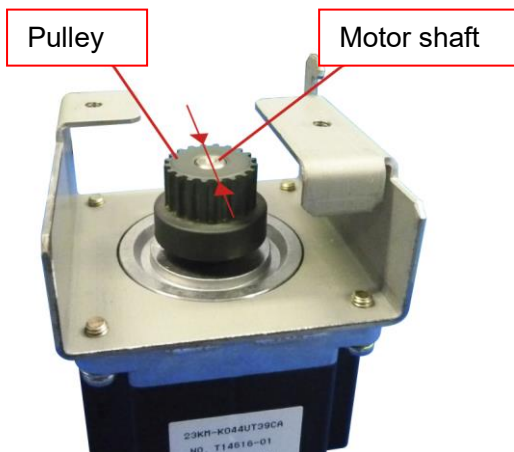

- (7) Mount the pulley so that the edge of the motor shaft is aligned with the top surface of the pulley.

- (8) After the replacement, mount the motor in the reverse order of the removal procedure.

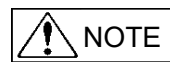

NOTE After replacing the motor, always adjust the belt tension. (Refer to page 2-15.)

2.2.11 Adjusting the Belt Tension

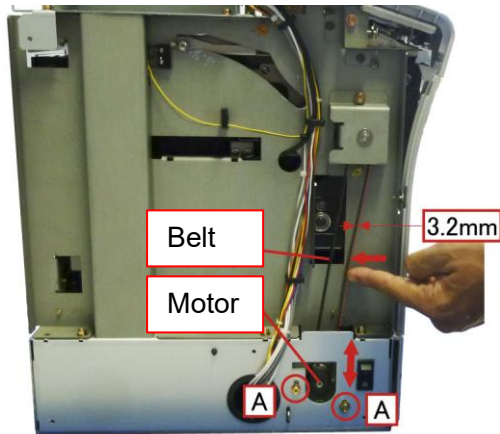

- (1) Remove the case body (left side).
(Refer to page 2-1.)
- (2) Make an adjustment so that the belt is deflected by 3.2 mm when a position near the center of the belt is pressed with a finger with a force of 200g (1.96N).
- (3) Loosen the two screws A for the motor side and adjust the position of the motor.
- (4) After the adjustment, tighten the two screws A and return the case body (left side) to the original position.

2.2.12 Replacing the Scale Cable

- (1) Remove all the case bodies except for the case body (rear). (Refer to pages 2-1 and 2-2.)

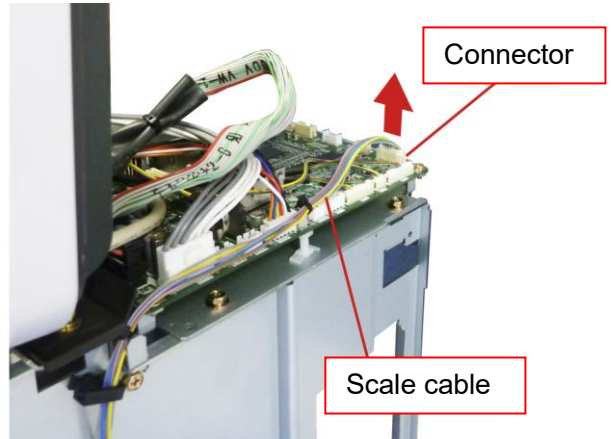
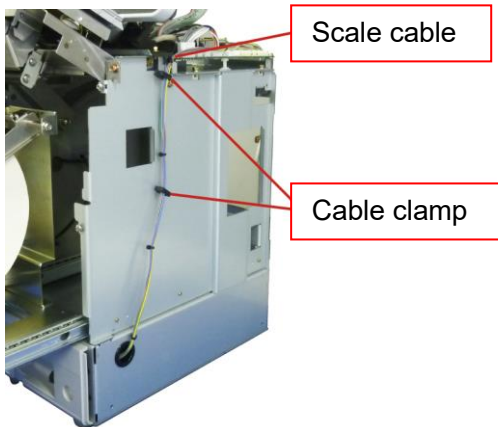

- (2) Remove the scale cable from the two cable clamps.

- (3) Remove the connector for the scale cable.

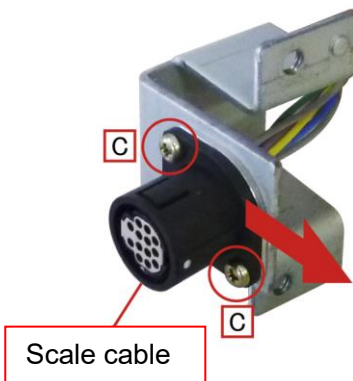
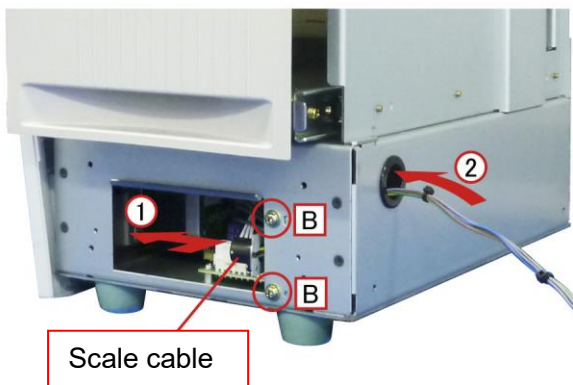

- (4) Remove the two screws B, and pull out the scale cable in the direction of the arrows 1 and 2.

- (5) Remove the two screws C, remove the scale cable from the bracket and replace it.

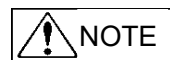
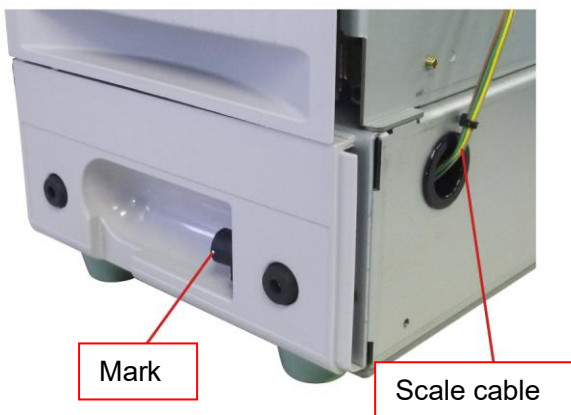

NOTE Mount the scale cable so that the mark is placed on the front side.

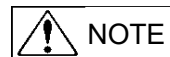

NOTE Wire the scale cable so that it does not get caught.

- (6) After replacing the scale cable, mount it in the reverse order of the removal procedure.

2.2.13 Adjusting the Ball Catch Position

Adjust the catch position for the cassette lock. If the label cassette is pushed forward, the position needs to be adjusted.

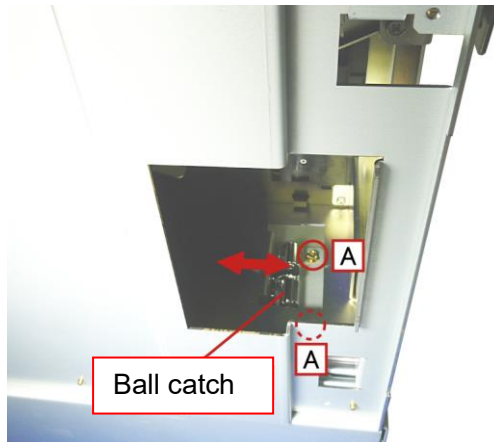

- (1) Remove the case body (top), case body (right side) and case body (rear). (Refer to pages 2-1 and 2-2.)
- (2) Pull out the label cassette.
- (3) Loosen the two screws A, move the ball catch back and front, and adjust the position.
- (4) Lightly push the label cassette back and tighten the two screws A.
- (5) After the adjustment, return the case bodies (rear, right side and top) to the original positions.

2.3 Replacing the Display Unit

2.3.1 Replacing the Display Board

(1) Remove the case body (top). (Refer to page 2-1)

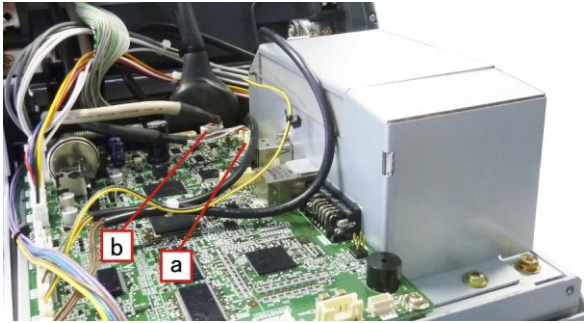

(2) Remove the connectors a and b.

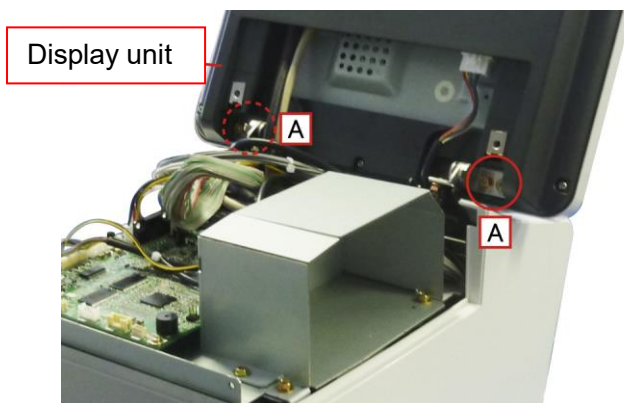

(4) Remove the four screws and remove the display unit.



NOTE

When removing the display unit, hold it so that it will not overturn.

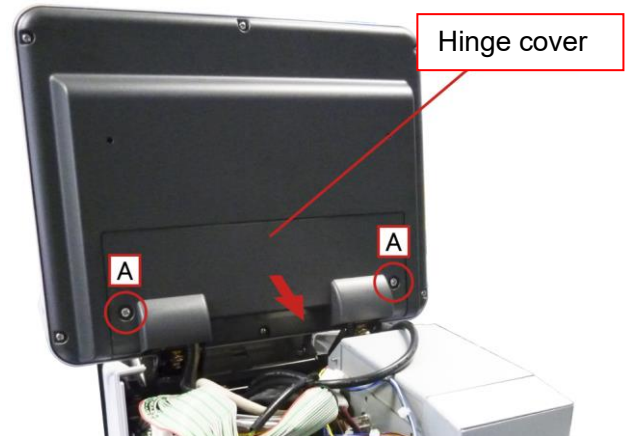
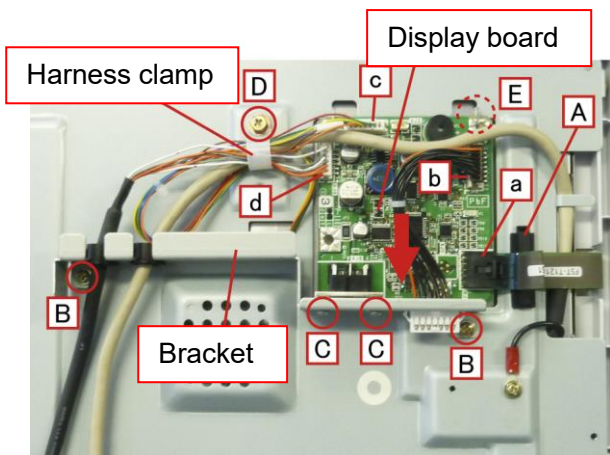

(3) Remove the two screws A and remove the hinge cover.

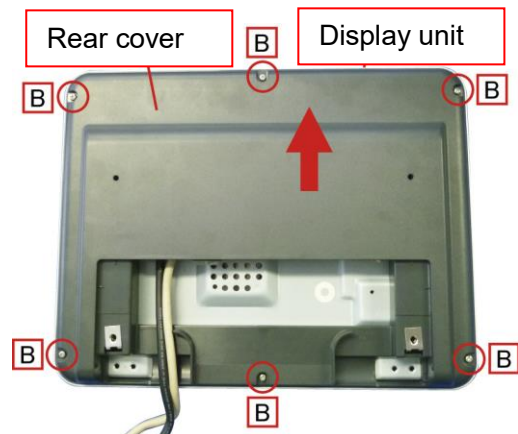

(5) Remove the six screws B and remove the rear cover.

(6) Open the harness holder A and remove the connectors a to d.

(7) Remove the two screws B, two screws C and one screw D, and remove the bracket together with the harness clamp.

(8) Remove the display board in the direction of the arrow while avoiding contact with the claws E.

(9) After replacing the display board, mount it in the reverse order of the removal procedure.

2.3.2 Replacing the Display

- (1) Remove the rear cover by following steps 1 to 5 of the procedure to replace the display board.
(Refer to page 2-21.)

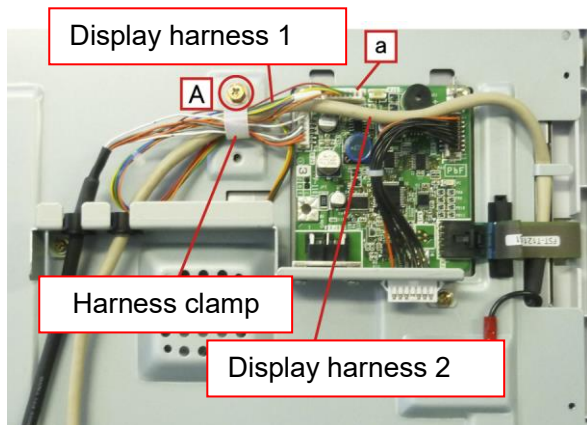

- (2) Remove the connector a.
(3) Remove the screw A and remove the display harnesses 1 and 2 from the harness clamp.

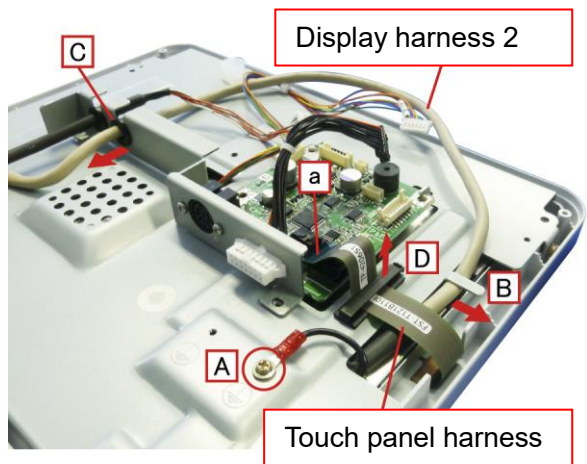

- (4) Remove the screw A and claw B, pull out the harness clamp C, and then remove the display harness 2.
(5) Open the harness holder D, remove the connector a, and remove the touch panel harness.

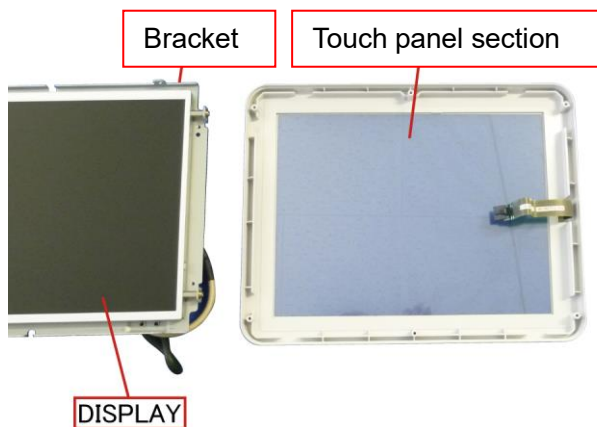

- (6) Remove the display together with the bracket from the touch panel section.

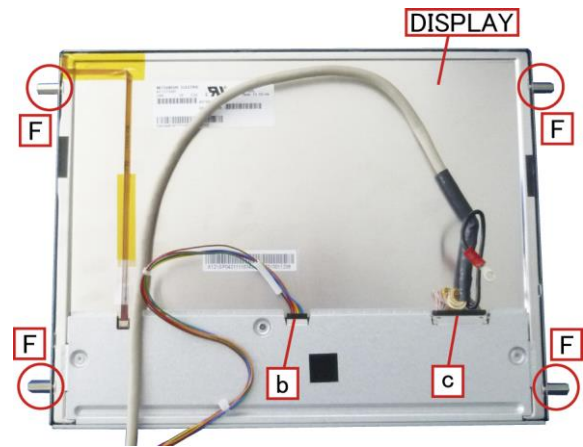
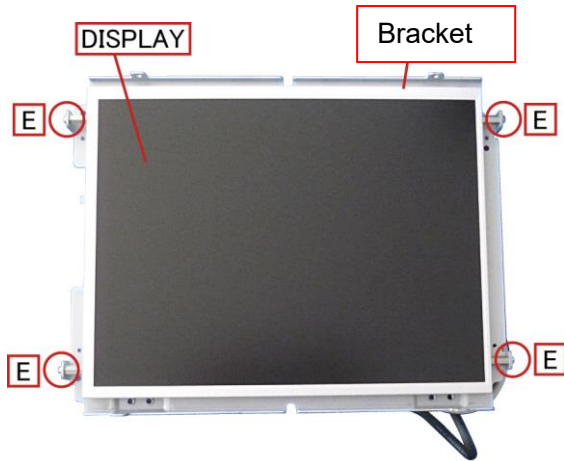

(7) Remove the four screws E and remove the display from the bracket.

(8) Lay the display face down, remove the four hexagonal screws F, and remove the connectors b and c.

(9) After replacing the display, mount it in the reverse order of the removal procedure.

2.3.3 Replacing the Touch Panel

(1) Remove the touch panel section by following steps 1 to 6 of the procedure to replace the display. (Refer to page 2-22.)

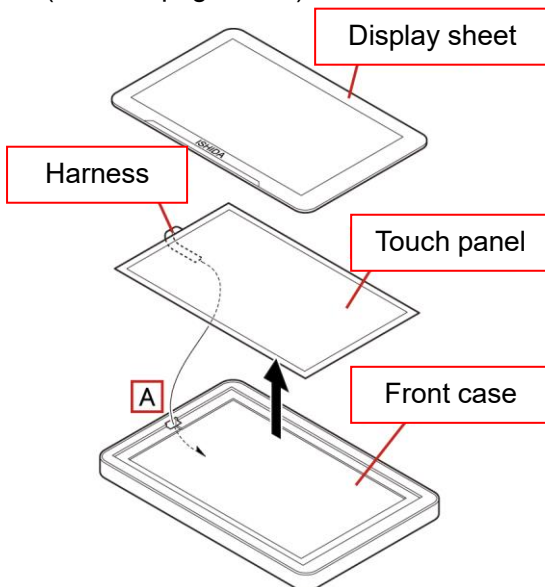

(2) Remove the display sheet from the front case.

(3) Remove the touch panel from the front case while pulling out the harness from the hole A.

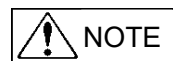

NOTE The display sheet is attached to the touch panel with an adhesive tape. This tape cannot be reused once it has been peeled off. Always replace it with a new one.

(4) After replacing the touch panel, mount it in the reverse order of the removal procedure.

2.4 Replacing the Weighing Unit

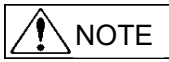

NOTE

After replacing the load cell and A/D board and adjusting the span, it is necessary to do a verification test after attaching a new approval seal.

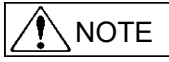

NOTE

Refer to the Technical Reports No.SC216131 "About the version change of P-1111 board" and No.SC226141 "Version change of P-1111 board (return to original)" at the beginning.

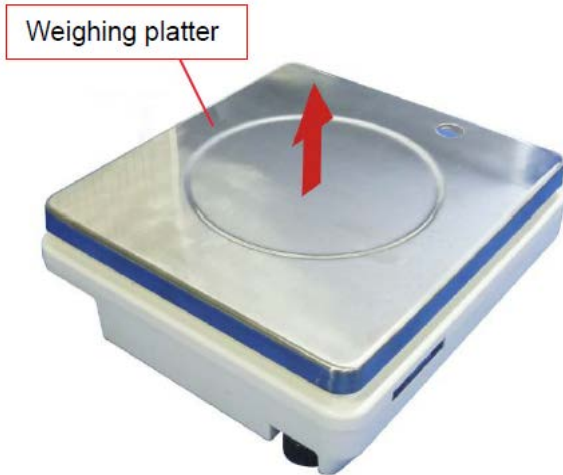

(1) Remove the weighing platter.

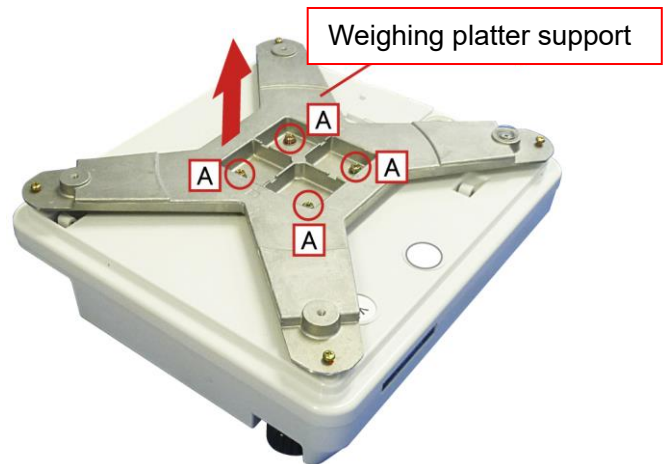

(2) Remove the four screws A and remove the weighing platter support.

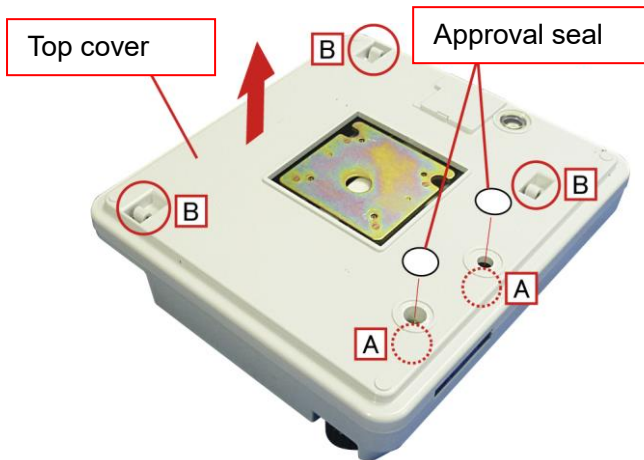

(3) Peel off the two approval seals, remove the screw A under the seal, and remove the three claws B. Then, remove the upper case.

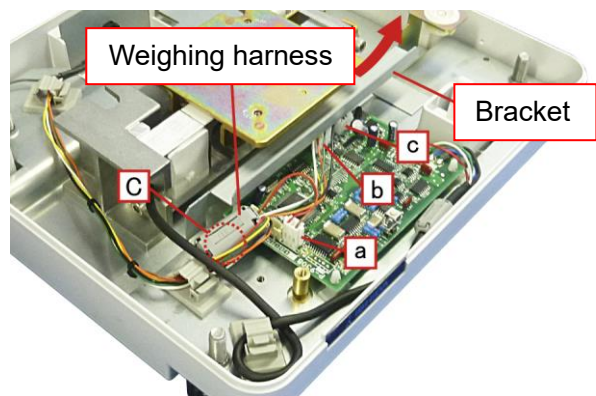

(4) Remove the connectors a, b and c, remove the screw C under the weighing harness, and remove the bracket.

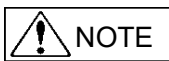

NOTE

The approval seal cannot be reused once it has been peeled off.

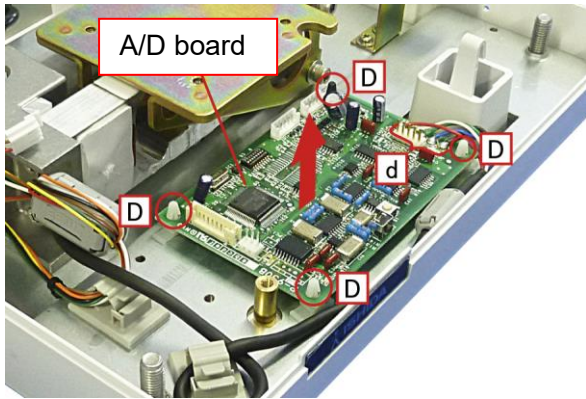

(5) Remove the solder d from the five points, remove the board holders D from the four points, and then remove the A/D board.

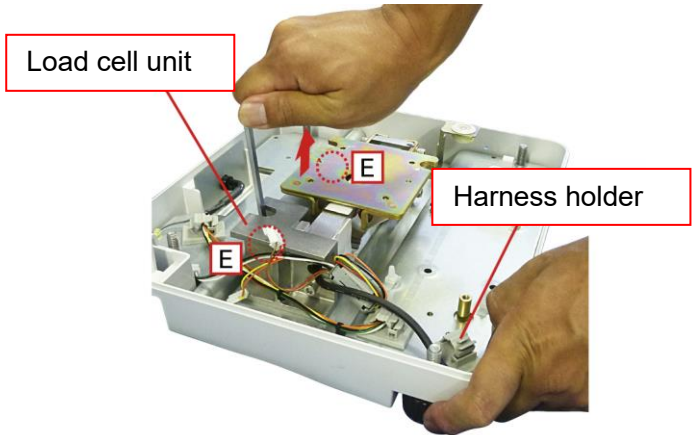

(6) Remove the two socket head bolts E with a hexagon wrench.

(7) Open the harnesses holder and remove the load cell unit.

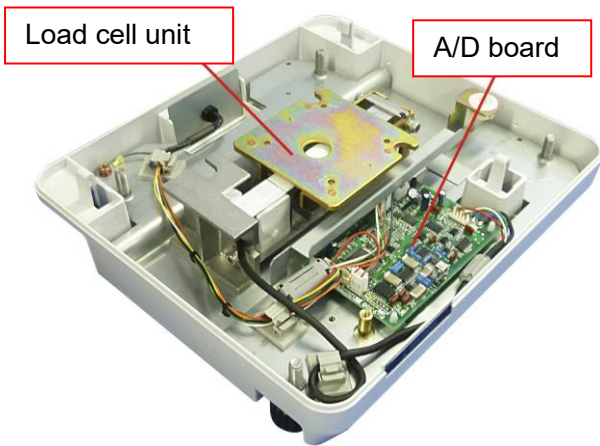

(8) After replacing the A/D board and the load cell unit, mount them in the reverse order of the removal procedure.

(9) After mounting, adjust the weighing unit.

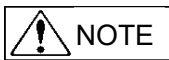

NOTE

After adjusting the weighing unit, make sure to replace the approval seal that has been peeled off in step 3 with a new one and attach it.

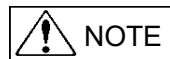

NOTE

Mount the top cover so that there is no gap. If there is a gap, it is not possible to measure weights correctly.

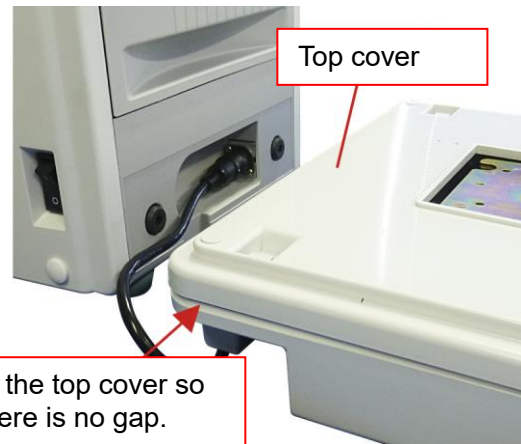

2.5 Replacing the Numerical Keypad Cover (Optional)

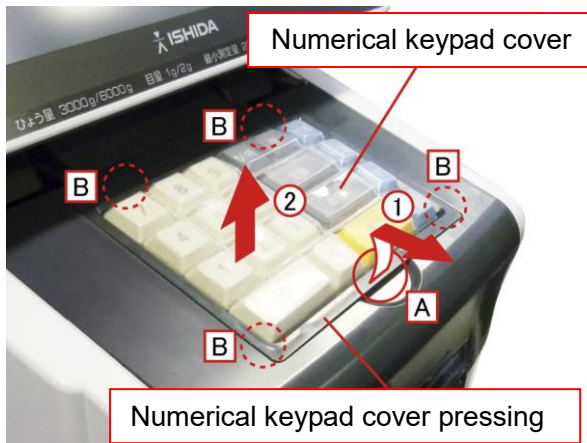

- (1) Lift up the part A, remove the numerical keypad cover pressing in the direction of the arrow 1 while removing the claws B from four points.
- (2) Remove the numerical keypad cover (optional) in the direction of the arrow 2, and replace it.

2.6 Wireless LAN kit overseas edition expansion (Optional)



(1) Open the side cover.

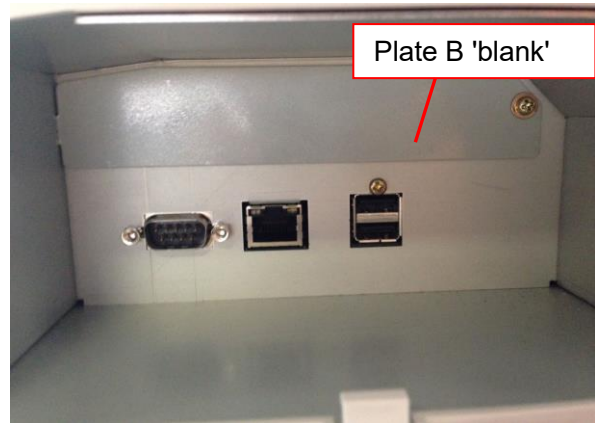

(2) Remove the cover 'blank'.

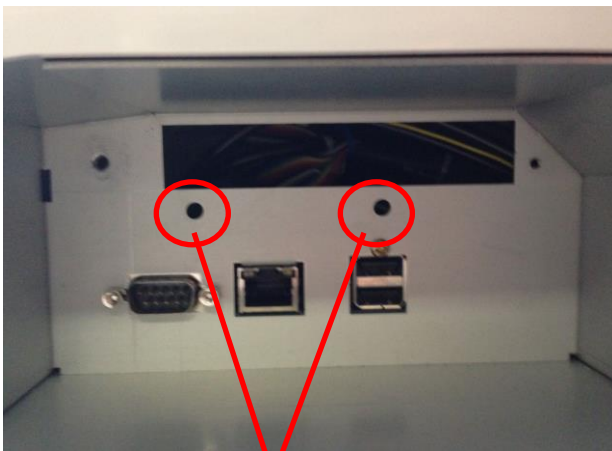

Positions to fasten the screws that are included at shipping.



Remove the screws on these two positions.

(3) Remove the upper cover.

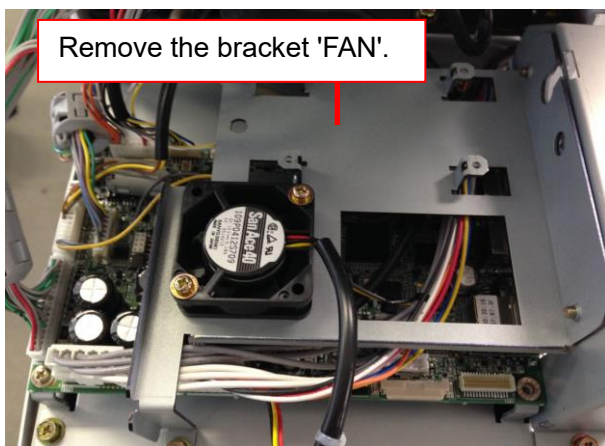

Remove the bracket 'FAN'.

(4) Remove the bracket 'FAN'.

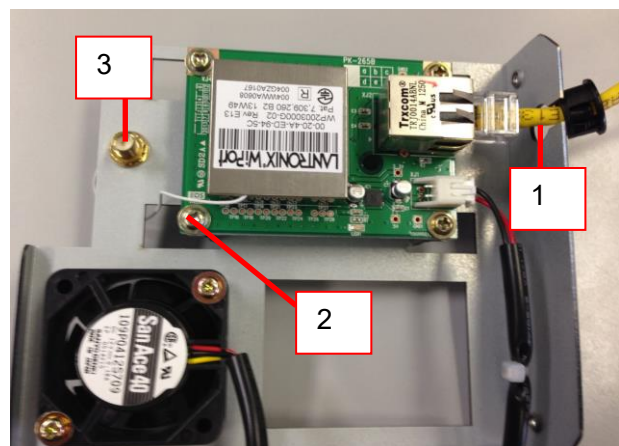

(5) Mount the PWB'PK-265.

1: Attach the harness' S2'LAN

2: Attach four places of PWB'PK-265 with a bundled TP screw (3 X 6).

3: Screw the antenna base to fix.



(6) Antenna mounting



(7) Put the bracket 'FAN' back to the based position .



(8) In the case of the United States and Canada specifications, put the following sticker in the space vacated on the nameplate.

2.7 Curling inward label correspondence (Optional)

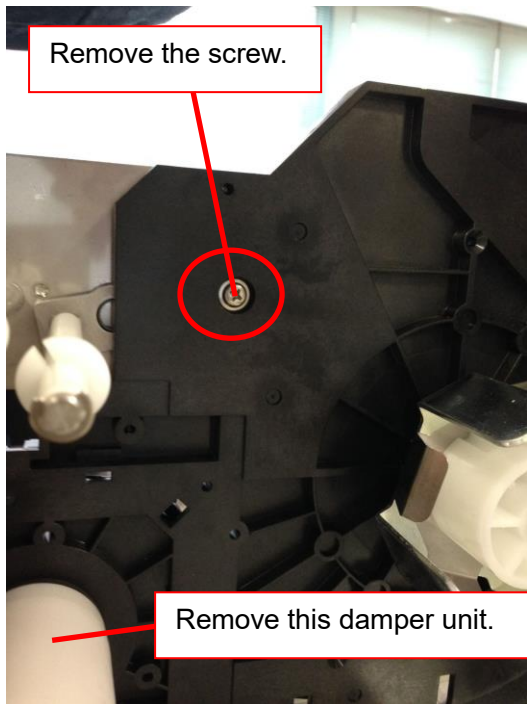

(1) Open the side cover.

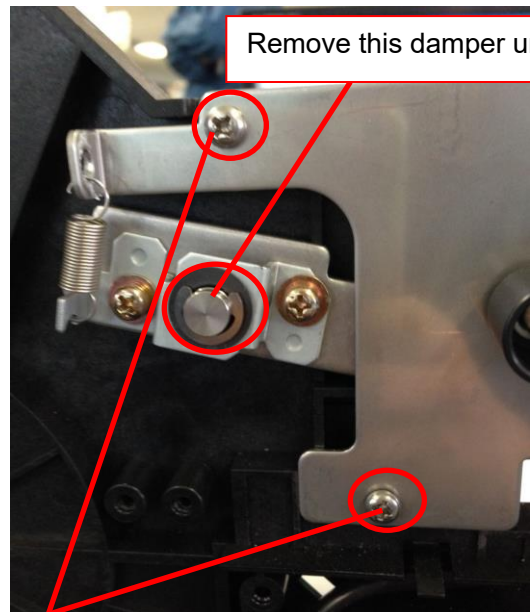

Remove these two positions of the screws and pull the damper unit.
Then, put the screws back to the original position.

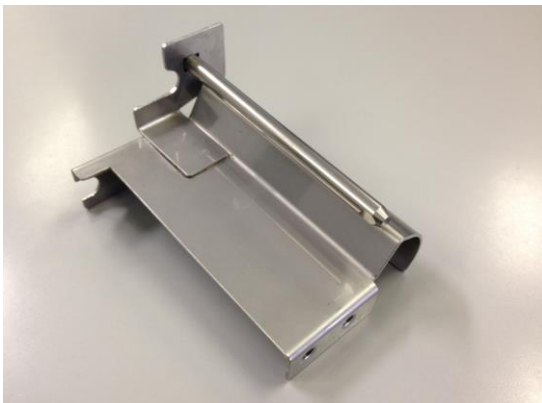

(2) Attach the Curling inward label bracket.

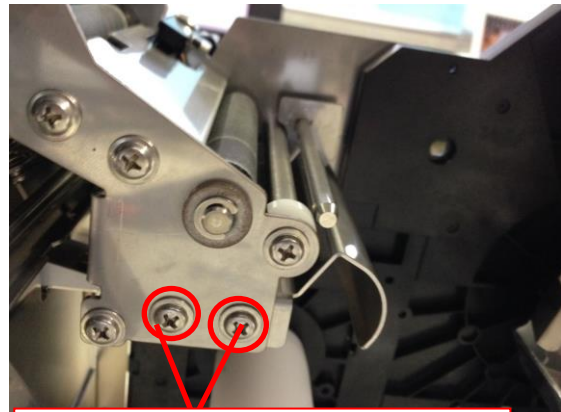

(3) Replace the label route diagram to the diagram of curling inward specifications.

* Either replacing or sticking over will be OK.

Chapter 3 Electric Components

3.1 PCB Configuration of the Electric Part

CAUTION The logic system 24 VDC power supply will not turned off unless unplugged.

CAUTION If the fuse is blown, always replace it with a specified fuse.

3.1.1 Main Board

P1100A-2 (Product No. 100-002-9443-00)

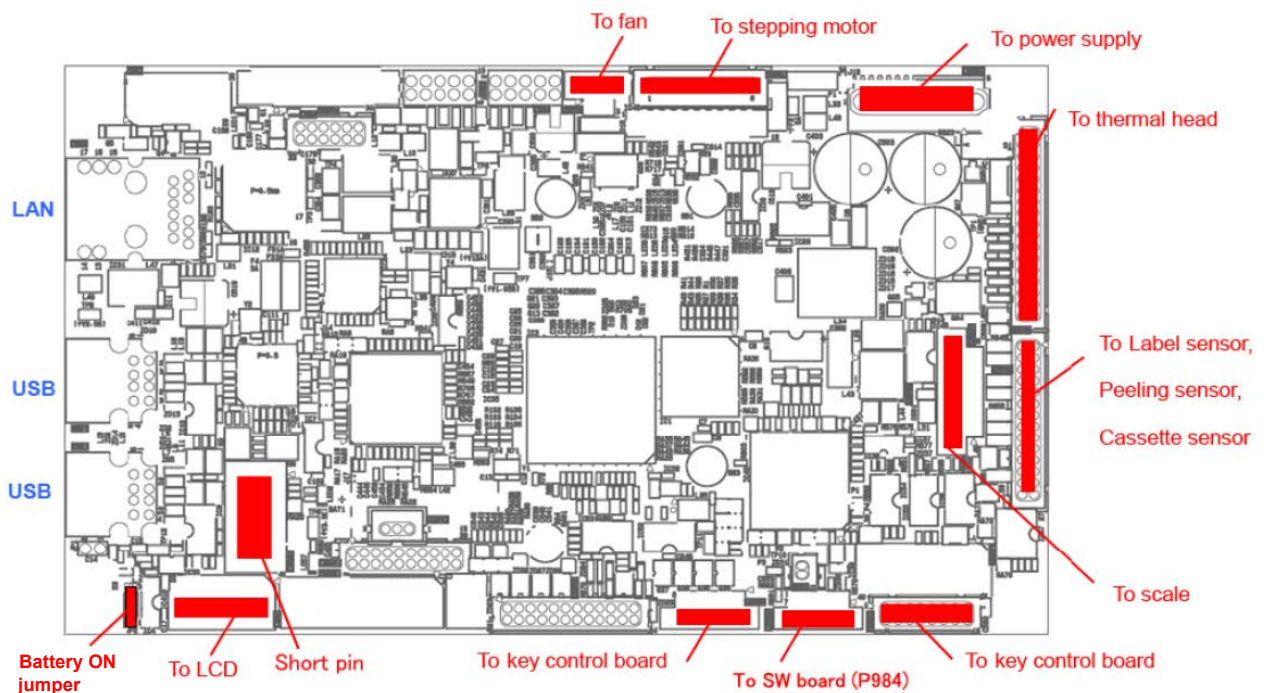

- Connectors

Connector No.	Connected to	Reference
XJ1	Not used.	
XJ2	Not used.	
XJ3	Not used.	
XJ4	Not used.	
XJ5	Not used.	
XJ6	Not used.	
XJ7	Not used.	
XJ8	Not used.	
XJ9	LCD	
XJ10	Stepping motor	
XJ11	Not used.	
XJ12	Not used.	
XJ13	Power supply	
XJ14	Not used.	
XJ15	Short pin	
XJ16	Scale	
XJ17	Thermal head	
XJ18	Not used.	
XJ19	Not used.	
XJ20	Fan	
XJ21	Label sensor Peeling sensor Cassette sensor	
XJ22	Not used.	
XJ23	SW board (P984)	
XJ24	Not used.	
XJ25	Key control board (P1102-1) Option wireless module	
XJ26	Not used.	

- DIPSW

Switch name	Switch No.	Setting	Remarks
SW1	1	OFF	Always OFF
	2	OFF	Always OFF
	3	OFF	Always OFF
	4	OFF	Always OFF

- Battery

Type	ON/OFF	Replacement
Short pin	Turned ON with socket inserted into 1-2.	Jumper is located at the front left corner of the board - near the USB ports

3.1.2 Key Control Board

P1102-4 (Product No. 100-003-3188-**)

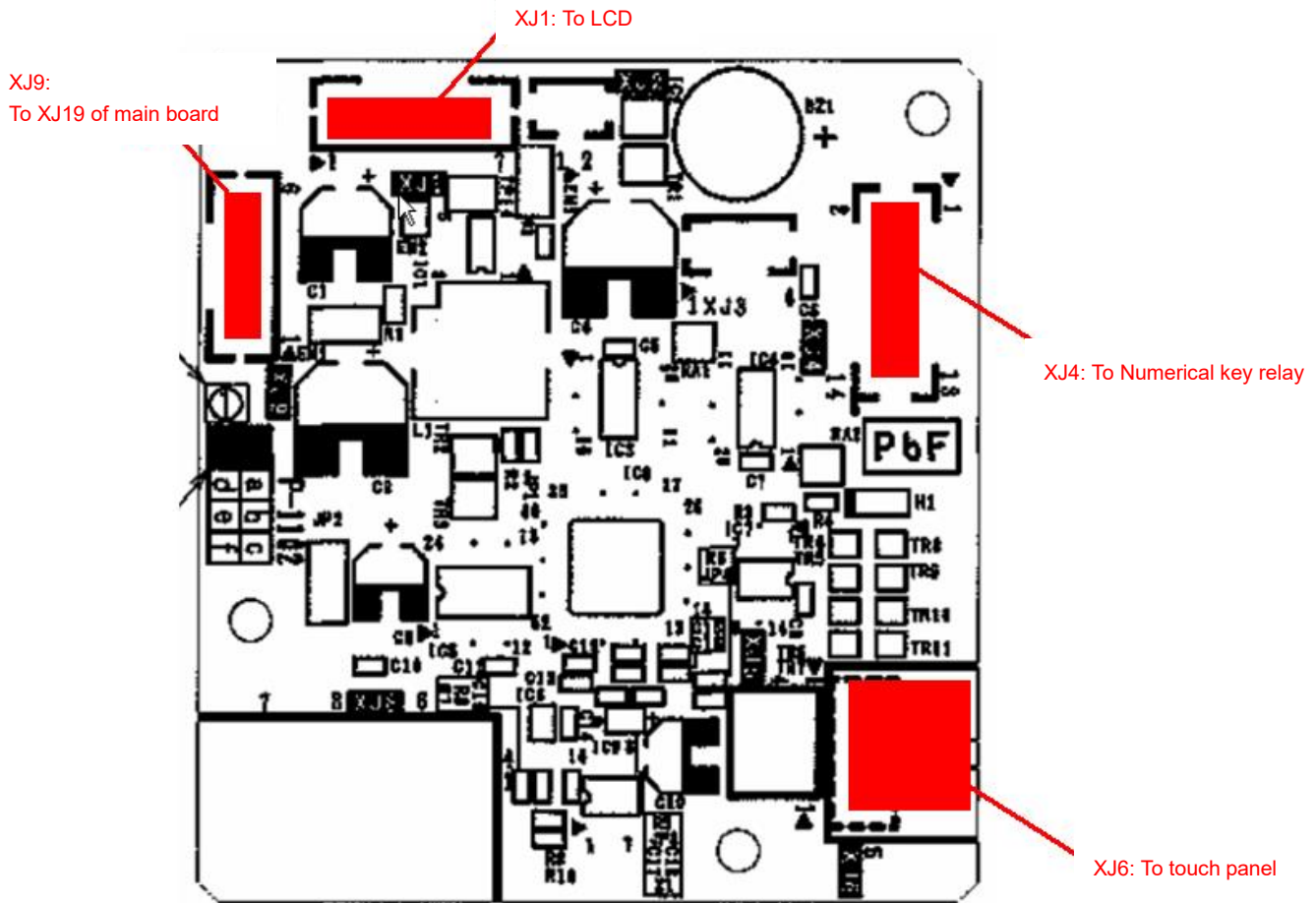

- Connectors

Connector No.	Connected to	Reference
XJ1	Not used.	
XJ2	Not used.	
XJ3	Not used.	
XJ4	Numerical key relay	
XJ5	Not used.	
XJ6	Touch panel	
XJ7	Not used.	
XJ8	Optional RS232C scanner	
XJ9	P-1100A XJ25	

3.1.3 Scale Board

P-1111A-2 (Product No. 100-003-3404-**)

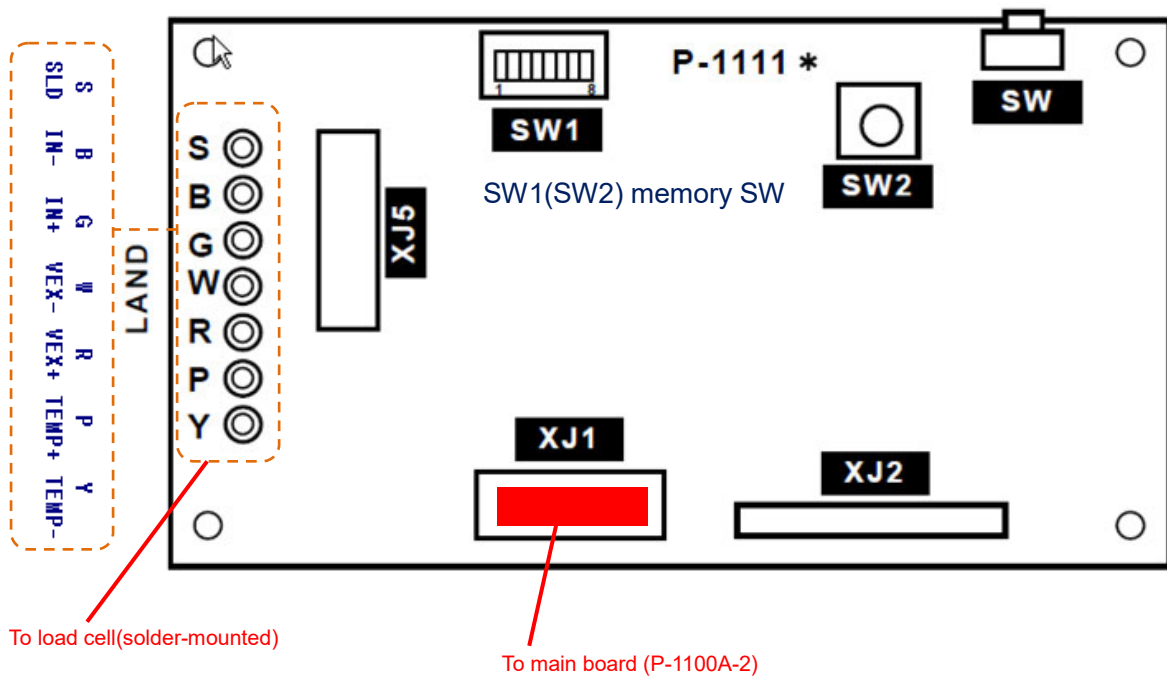

- Connectors

Connector No.	Connected to	Reference
XJ1	P-1100 main board	
XJ2	Not used.	
XJ3	Not used.	
XJ4	Not used.	
XJ5	Load cell	

- DIP switch

Switch name	Switch No.	Setting	Remarks
SW1	1	OFF	Always OFF
	2	ON	for verify pairing
	3	OFF	Always OFF
	4	OFF	Always OFF
	5	OFF	Always OFF
	6	OFF	Always OFF
	7	OFF	Always OFF
	8	OFF	Always OFF

Chapter 4 Setup Mode

4.1 Startup

Turn on the power.

Power switch



The PREPACK screen in the OPERATE mode appears.

Press  at the upper right side of the screen.



The menu appears in the OPERATE MODE.

Press the [SET UP] button on the screen.

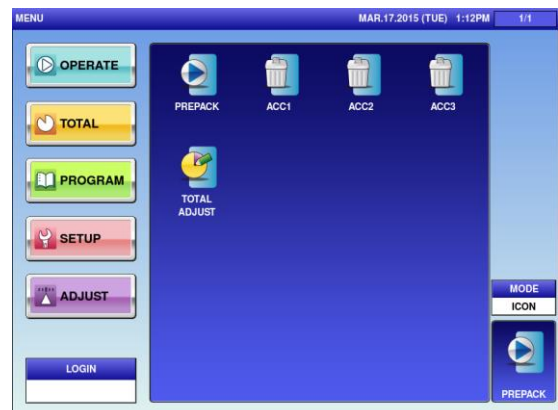

The User Menu screen in the Setup mode appears.

Input the password “495344” using the numerical keys, and press the [LOGIN] button on the screen.

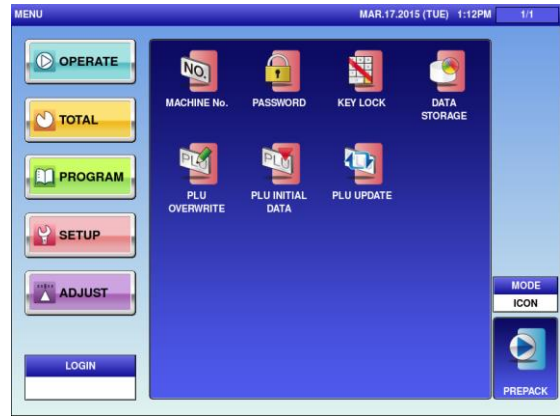

The Maintenance Menu screen appears in the Setup mode.

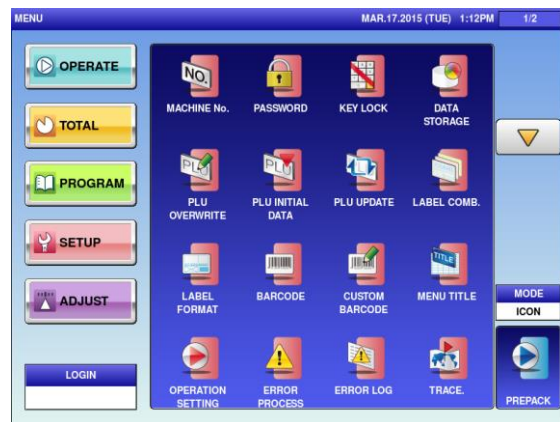

Maintenance Menu screen 1/2

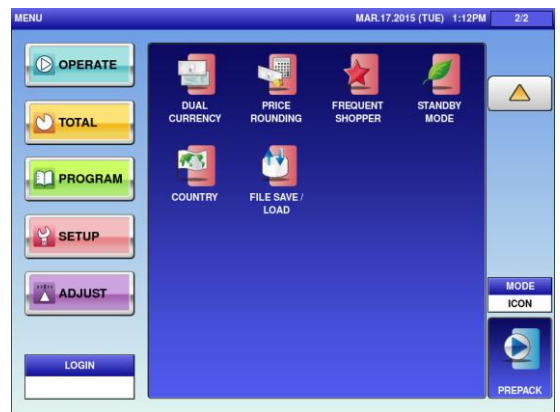

Maintenance Menu screen 2/2

4.2 MACHINE NO. SETTING

4.2.1 MACHINE No. (BASIC)

Menu name	Specification
	Return to Menu. Other tabs also have the same function.
NETWORK No.	Set the machine No. Input range: 0 to 9999
MACHINE SET	Select one of the stand-alone, master or satellite machines. ALONE / MASTER / SAT. This function is enabled only when you log into the service network. The confirmation dialog appears when ALONE, MASTER and SAT. are selected respectively.

4.2.2 MACHINE No. (IP ADDR.)

Menu name	Specification
IP ADDRESS	Set the IP address. Input range: "0.0.0.0" to "255.255.255.255"
SUBNET MASK	Set the subnet mask. Input range: "0.0.0.0" to "255.255.255.255"
DEFAULT GATEWAY	Set the default gateway. Input range: "0.0.0.0" to "255.255.255.255"
DNS SERVER1	Set the IP address of Primary DNS server. Input range: "0.0.0.0" to "255.255.255.255"
DNS SERVER2	Set the IP address of Secondary DNS server. Input range: "0.0.0.0" to "255.255.255.255"
DHCP MODE	Select whether or not to use DHCP.
PING TO PC	Ping the PC. Other tabs also have the same function.
	Enter "."(dot). Used for IP address setting. Other tabs also have the same function.

4.2.3 MACHINE No. (PC COM)

Menu name	Specification
PC IP ADDRESS	Set the PC's IP address. Input range: "0.0.0.0" to "255.255.255.255"
PC PORT No.	Set the PC's port No. Input range: 0 to 65535
COM CHECK PERIOD (SEC)	Set the command check period. Input range: 0 to 9999
COM CHECK TIME OUT (SEC)	Set the command check time-out. Input range: 2 to 5
ERROR LOG SEND	Set whether or not to send the error log.
FIELD NAME ENABLE	Select and set whether or not to add filed name to the CSV title line of the transmission data.
PRESET FUNC. NAME REFER	Select the preset function name reference. COM.DATA / PLU
LAN CONNECT CHECK	Set whether or not to perform LAN connect check.
PROD. TRAN SEND	Set whether or not to perform transmission of Production Transaction. (SLP-5)

4.2.4 MACHINE No. (WiFi)

Menu name	Specification
SECURITY / AUTHENTICATION / ENCRYPTION	Select the method of security/authentication/encryption. NONE / WEP64 / WEP128 / WEP64 Shared Key / WEP128 ShKey / WPA PSK TKIP / WPA PSK CCMP / WPA2 PSK TKIP / WPA2 PSK CCMP
SSID(WIRELESS NETWORK NAME)	Set the SSID. Pressing the button opens the Editor screen to edit.
KEY TYPE	Select the WEP key index. HEX / ASCII / PASSPH
WEP KEY INDEX	Select the WEP key index. 1 / 2 / 3 / 4 This function is enabled only when one of WEP64 / WEP128 / WEP64 Shared Key / WEP128ShKey is selected for security / authentication / encryption.
WEP64 KEY	Set the WEP64 Key. Up to 5 bytes This function is enabled only when one of WEP64 / WEP128 / WEP64 Shared Key / WEP128ShKey is selected for security / authentication / encryption.

4.2.5 MACHINE No. (GLOBAL SV.)

Menu name	Specification
GLOBAL SERVICE ENABLE	Select and set whether or not to use the cloud function (Global Service).
The following parameters are valid only when the GLOBAL SERVICE ENABLE setting is set to [ENABLE] (grayed out when set to [DISABLE])	
GLOBAL SERVICE URL	Set the URL of Cloud server (only when the function is valid). Press the button to open the Editor screen to edit.
PROXY SERVER URL	Set the URL of Proxy server (only when the function is valid). Press the button to open the Editor screen to edit.
PING TO SERVICE	Send PING to the set cloud server (When the cloud function is not in use, the option is grayed out).

4.2.6 MACHINE No. (SYNC.)

The screenshot shows a web-based configuration interface for a device. The window title is "MACHINE No. (SYNC.)" and the top right corner displays the date and time "06-03-2014 (THU) 9:20". The main content area is divided into sections. At the top, there is a blue header "CLOCK SYNC. WITH NTP SERVER" with two buttons: "DISABLE" (grayed out) and "ENABLE" (yellow). Below this is a text input field labeled "NTP SERVER URL" containing the text "ntp.nict.jp". To the right of the main content area is a vertical sidebar with a yellow arrow icon at the top and a red "PING" button. At the bottom of the window, there is a horizontal menu with several tabs: "BASIC", "IP ADDR.", "PC COM", "WIFI", "GLOBAL SV.", and "SYNC.". The "SYNC." tab is currently selected.

Menu name	Specification
CLOCK SYNC. WITH NTP SERVER	Select and set whether or not to use the clock synchronization.
NTP SERVER URL	Set the URL of NTP server. When this function is not in use, the option is grayed out. Press the button to open the Editor screen to edit.

4.2.7 MACHINE No. (OUTSIDE PRINTER)

MACHINE No. (OUTSIDE PRINTER) MAR.28.2014 (FRI) 2:36PM

No.	CONNECT		IP ADDRESS
1	USB	LAN	0.0.0.0

PING

BASIC IP ADDR. PC COM WiFi GLOBAL SV. OUTSIDE PRN SYNC.

Menu name	Specification
CONNECT	Select and set the connection method for external printer. USB / LAN
IP ADDRESS	Set the IP address of the printer when the LAN connection is selected When the USB is selected, this option is grayed out.

4.3 PASSWORD

4.3.1 PASSWORD (OPERATE)

PASSWORD (OPERATE) 06-03-2014 (THU) 10:50 1/1

PASSWORD 000000

MENU NAME	SELECT	
(1001) SALES	USE	NO USE
(1003) ACC1	USE	NO USE
(1004) ACC2	USE	NO USE
(1005) ACC3	USE	NO USE
(1002) TOTAL ADJUST	USE	NO USE
	USE	NO USE
	USE	NO USE

OPERATE TOTAL PROGRAM SETUP ADJUST

Menu name	Specification
PASSWORD	Set the password in six digits. Logging in by this password will release the menu operation prohibited status.
MENU NAME	Display the menu name. Both USE and NO USE for SALES are grayed out because SALES cannot be locked with the password.
SELECT	Select whether or not to lock with the password. USE: Locked NO USE: Not locked

(All tabs have the same operations so their explanations are omitted here.)

4.4 KEY LOCK

4.4.1 KEY LOCK (DISPLAY KEY)

KEY LOCK (DISPLAY KEY) 06-03-2014 (THU) 11:13 1/1

PASSWORD 000000

KEY NAME	KEY LOCK	
PLU NAME AREA	YES	NO
TARE	YES	NO
WEIGHT/PRICE	YES	NO
PCS	YES	NO
	YES	NO
	YES	NO
	YES	NO

DISPLAY KEY FUNCTION KEY STROKE KEY

Menu name	Specification
PASSWORD	Set the password in six digits. Normally in the PRODUCTION screen, enter this password and press KEY LOCK FUNCTION to release the input prohibited status.
KEY NAME	Display the measurement menu on the normal mode screen.
KEY LOCK	Select whether or not to set a key lock. YES: The key lock is set. NO: The key lock is not set.

4.4.2 KEY LOCK (FUNCTION KEY)

KEY LOCK (FUNCTION KEY) 06-03-2014 (THU) 11:13 1/19

PASSWORD 000000

KEY NAME	KEY LOCK	
	YES	NO
PLU	YES	NO
TARE	YES	NO
F/P	YES	NO
MULTI	YES	NO
SPECIAL	YES	NO
-€	YES	NO
-%	YES	NO

DISPLAY KEY FUNCTION KEY STROKE KEY

Menu name	Specification
PASSWORD	Set the password in six digits. Normally in the PRODUCTION screen, enter this password and press KEY LOCK FUNCTION to release the input prohibited status.
KEY NAME	Display the function key name.
KEY LOCK	Select whether or not to set a key lock. YES: The key lock is set. NO: The key lock is not set.

4.4.3 KEY LOCK (STROKE KEY)

KEY LOCK (STROKE KEY) 06-03-2014 (THU) 12:00 1/1

PASSWORD 000000

KEY NAME	KEY LOCK	
TARE	YES	NO
UNIT PRICE	YES	NO
FIXED PRICE	YES	NO
PRESET	YES	NO
	YES	NO
	YES	NO
	YES	NO

DISPLAY KEY FUNCTION KEY STROKE KEY

Menu name	Specification
PASSWORD	Set the password in six digits. Normally in the PRODUCTION screen, enter this password and press KEY LOCK FUNCTION to release the input prohibited status.
KEY NAME	Display the stroke key name.
KEY LOCK	Select whether or not to set a key lock. YES: The key lock is set. NO: The key lock is not set.

4.5 DATA STORAGE

4.5.1 DATA STORAGE (TOTAL ADD.)

MENU NAME		SELECT	
DAILY TOTAL	NON ADD	ADD	
WEEKLY TOTAL	NON ADD	ADD	
CUMULATIVE TOTAL	NON ADD	ADD	
TIME TOTAL	NON ADD	ADD	
OPERATOR TOTAL	NON ADD	ADD	
ACC1 TOTAL	NON ADD	ADD	
ACC2 TOTAL	NON ADD	ADD	
ACC3 TOTAL	NON ADD	ADD	

TOTAL ADD. TOTAL PROC. TRANSACTION STORAGE

Menu name	Specification
MENU NAME	Display the menu name.
SELECT	Select whether or not to add. NON ADD / ADD
The TOTAL PROC. / TRANSACTION / STORAGE tabs are displayed only when you access above menus after logging in with the service password.	

4.5.2 DATA STORAGE (TOTAL PROC.)

DATA STORAGE (TOTAL PROC.) 06-03-2014 (THU) 12:04

FIX PRICE ITEM ADD WEIGHT

FIX WEIGHT REAL WEIGHT

WRAP MODE WEIGHT ADD

NON ADD ADD

TOTAL ADD. TOTAL PROC. TRANSACTION STORAGE

Menu name	Specification
FIX PRICE ITEM ADD WEIGHT	Select the addition weight of fixed-price items. FIX WEIGHT / REAL WEIGHT
WRAP MODE WEIGHT ADD	Select and set whether or not to perform Weight Add in the production in the WRAP mode.

4.5.3 DATA STORAGE (TRANSACTION)

DATA STORAGE (TRANSACTION) 06-03-2014 (THU) 12:04

PROD. TRANSACTION

NON ADD
ADD

TRANS. MEM. FULL

STOP
OVER WRITE



TOTAL ADD.

TOTAL PROC.

TRANSACTION

STORAGE

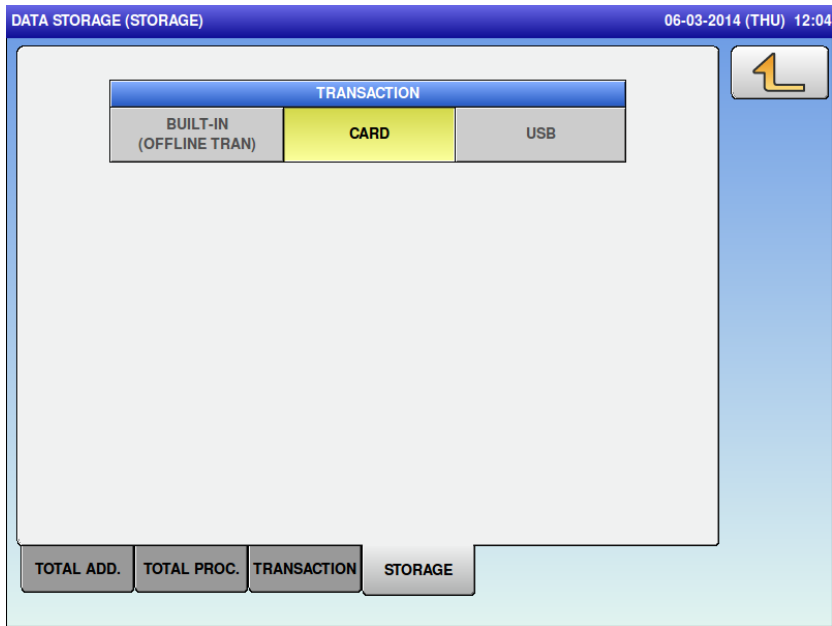

Menu name	Specification
PROD. TRANSACTION	Select whether or not to add the product transaction. NON ADD / ADD
TRANS. MEM. FULL	Select between stopping or overwriting the transaction addition at full memory condition. STOP / OVERWRITE

4.5.4 DATA STORAGE (STORAGE)



Menu name	Specification
TRANSACTION	Select where to save the transaction. BUILT-IN / CARD / USB

4.6 PLU OVERWRITE

PLU MASTER LIST		SELECT	
UNIT PRICE:FIX PRICE	YES	NO	 
MARKDOWN MODE:M/D AMOUNT	YES	NO	
UNIT TYPE:QTY	YES	NO	
FIXED WEIGHT	YES	NO	
PACK DATE/TIME	YES	NO	
SELL BY DATE/TIME	YES	NO	
TARE	YES	NO	
EXTRA MSG.1	YES	NO	
INGREDIENT	YES	NO	
EXTRA MSG.3	YES	NO	

Menu name	Specification
PLU MASTER LIST	Display the PLU master item.
SELECT	Select whether or not to automatically update the PLU master item. YES / NO

4.7 PLU INITIAL DATA

4.7.1 PLU INITIAL DATA (SALE1)

Menu name	Specification
	Used to enter fractions. (Valid only when entering the fixed No. of items.) Other tabs also have the same function.
(Each item)	Set the initial value to newly create the PLU master.

4.7.2 PLU INITIAL DATA (MSG.)

PLU INITIAL DATA (MSG.) MAR.20.2014 (THU) 9:49AM 1/3

NUTRITION	0	NONE
EXTRA MSG.1	0	NONE
INGREDIENT	0	NONE
EXTRA MSG.3	0	NONE
COUPON MSG.	0	NONE
POP MSG.	0	NONE
COOKING TIME	0	NONE
FREE MSG.1	0	NONE

Menu name	Specification
(Each item)	Set the initial value to newly create the PLU master.

4.7.3 PLU INITIAL DATA (IMAGE)

PLU INITIAL DATA (IMAGE) MAR.20.2014 (THU) 9:49AM

IMAGE 1

0

IMAGE 2

0

IMAGE 3

0

SH. IMAGE

0

SAFE HANDLING IMAGE

NO PRINT

PRINT

SALE1

MSG.

IMAGE

PRINT

DATE

CODE

WRAP

Menu name	Specification
(Each item)	Set the initial value to newly create the PLU master. Pressing an image number item displays the image list.

4.7.4 PLU INITIAL DATA (PRINT)

PLU INITIAL DATA (PRINT) 05-04-2014 (SAT) 13:42

1

1st LABEL ATTACH TYPE < 0:REFER >	2nd LABEL TYPE < 1:NO >	1st LABEL BAR PRINT < 1:YES >
1st LABEL FORMAT No. 0	2nd LABEL FORMAT No. 0	
PRINT MODE < 1:YES >	1st LABEL PRINT < 1:YES >	2nd LABEL PRINT < 1:YES >
SUB LABEL PRINT < 1:YES >	EYECATCH LABEL PRINT < 1:YES >	

SALE1 MSG. IMAGE PRINT DATE CODE WRAP

Menu name	Specification
(Each item)	Set the initial value to newly create the PLU master.

4.7.5 PLU INITIAL DATA (DATE)

PLU INITIAL DATA (DATE) MAR.20.2014 (THU) 9:49AM

<div style="border: 1px solid gray; padding: 2px; background-color: #e0e0e0;">PACK DATE PRINT</div> <div style="display: flex; justify-content: space-between; padding: 2px;"> YES NO </div>	<div style="border: 1px solid gray; padding: 2px; background-color: #e0e0e0;">PACK TIME PRINT</div> <div style="display: flex; justify-content: space-between; padding: 2px;"> < 0:NO PRINT > </div>	<div style="border: 1px solid gray; padding: 2px; background-color: #e0e0e0;">PACK TIME DATA</div>	
<div style="border: 1px solid gray; padding: 2px; background-color: #e0e0e0;">SB DATE PRINT</div> <div style="display: flex; justify-content: space-between; padding: 2px;"> YES NO </div>	<div style="border: 1px solid gray; padding: 2px; background-color: #e0e0e0;">SB TIME PRINT</div> <div style="display: flex; justify-content: space-between; padding: 2px;"> < 0:NO PRINT > </div>	<div style="border: 1px solid gray; padding: 2px; background-color: #e0e0e0;">SB TIME DATA</div> <div style="padding: 2px; text-align: center;">0 MIN.(S) AFTER</div>	
<div style="border: 1px solid gray; padding: 2px; background-color: #e0e0e0;">SHELF LIFE(days)</div> <div style="padding: 2px;">NEXT DAY(1 day)</div>	<div style="border: 1px solid gray; padding: 2px; background-color: #e0e0e0;">USE BY DATE PRINT</div> <div style="display: flex; justify-content: space-between; padding: 2px;"> YES NO </div>	<div style="border: 1px solid gray; padding: 2px; background-color: #e0e0e0;">UB DATE DATA</div>	
<div style="border: 1px solid gray; padding: 2px; background-color: #e0e0e0;">DATE CAL</div> <div style="display: flex; justify-content: space-between; padding: 2px;"> YES NO </div>			

SALE1
MSG.
IMAGE
PRINT
DATE
CODE
WRAP

Menu name	Specification
(Each item)	Set the initial value to newly create the PLU master.

4.7.6 PLU INITIAL DATA (CODE)

PLU INITIAL DATA (CODE) MAR.20.2014 (THU) 9:49AM

ITEMCODE 00000000	REG. CODE 0	POS FLAG 02
BARCODE 00000000000000	POS REFERENCE < 0:REFER >	BARCODE TYPE 0:REFER
POS FORMAT (WGT) REFER	TRACE ENABLE YES NO	
DEPARTMENT 0	GROUP 00	

SALE1
MSG.
IMAGE
PRINT
DATE
CODE
WRAP

Menu name	Specification
(Each item)	Set the initial value to newly create the PLU master.

4.7.7 PLU INITIAL DATA (WRAP)

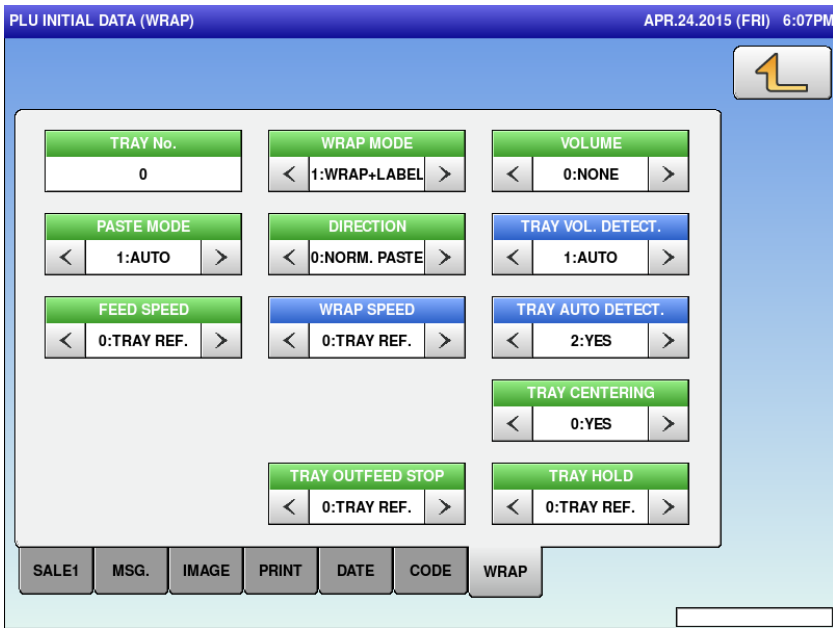

Menu name	Specification
(Each item)	Set the initial value to newly create the PLU master.

4.8 PLU UPDATE

CHANGE RANGE	
START No.	END No.
1	99999999

UNIT PRICE No.					CONDITION	
1	2	3	4	5	NO	YES

No.	LIST NAME	REPLACE CONDITION	CHANGE CONTENTS
1	ITEM CODE		
2	PACK DATE PRINT		
3	PACK TIME PRINT		
4	PACK TIME DATA		
5	SB DATE PRINT		
6	SB TIME PRINT		

BATCH DELETE

EXEC

Menu name	Specification
START No.	Set the start No. of the batch change range. Input range: 1 to 99999999
END No.	Set the end No. of the batch change range. Input range: 1 to 99999999
UNIT PRICE No.	Set the unit price No. for the batch change. Touch the button to change the selection.
CONDITION	Select whether or not to specify the replacement condition for the batch change. NO / YES
LIST NAME	Display the item for the batch change. Touch the button to change the selection.
REPLACE CONDITION	Specify the replacement condition. This function is enabled when [YES] is selected in [CONDITION].
CHANGE CONTENTS	Specify the replacement contents.
BATCH DELETE	Cancel all selections.
EXEC	Execute the batch change. The ALL REUPDATE CHECK dialog appears to ask whether to execute the batch change.

4.9 LABEL COMB

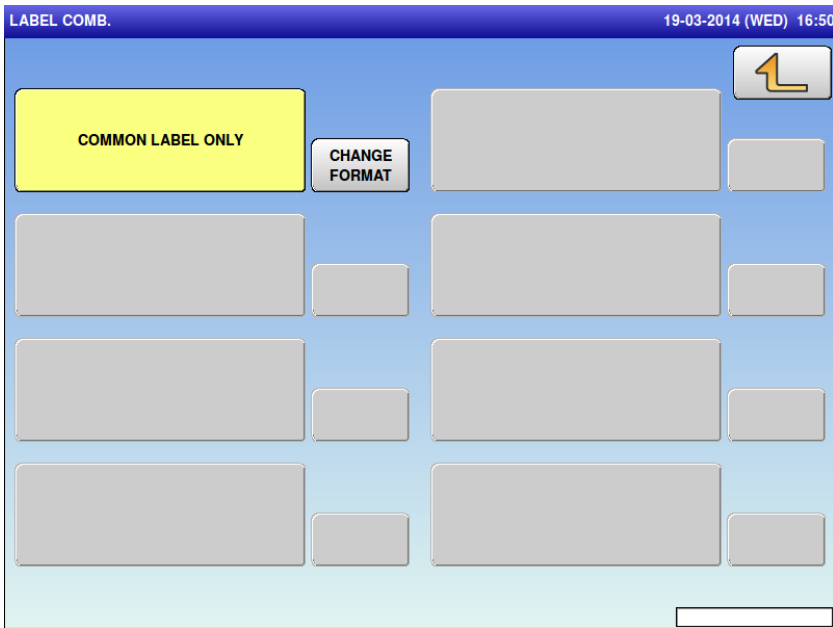

Menu name	Specification
CHANGE FORMAT	Open the LABEL COMB.(BASIC) screen.
COMMON LABEL ONLY	Set the print pattern to [COMMON LABEL ONLY].

4.9.2 LABEL COMB.(LABEL)

LABEL COMB.(LABEL) 19-03-2014 (WED) 18:13

PRINTER < PRN 1 >	CASSETTE No. 1	LABEL No. 01	 FEED PRINT MODIFY FORMAT DETAIL
LABEL TYPE < 1:130LA-1 >	PRINT DENSITY - 5 +	RED DENSITY - 5 +	
PRINT DIRECTION STAND. REVERSE	LABEL GAP 2.2mm	BACK FEED NO YES	
SENSOR TYPE < 2:MARK >	PRINT SPEED < 100mm/s >	PRE-STOP POS. 3.8mm	
SENSOR DISTANCE 51.0mm	FEED LENGTH 7.3mm	CONFIRM TO PRINT FMT No. 001 PLU No. 00000000	
		FORMAT INFO WIDTH 60.0 mm LENGTH 44.0 mm	
BASIC LABEL UPPER FIX			

Menu name	Specification
PRINTER	Select or set the printer by entering the number. Only the printer connected can be set.
LABEL No.	Set the label master No. Input range: 1 to 99 If there is no set master, the [LABEL SETTING MASTER IS NOT PROGRAMMED] dialog appears to ask whether to create a new master.
LABEL TYPE	Select the label type. 0: RECEIPT / 1: 130LA-1 / 3: 150LA-1
PRINT DENSITY	Set the print density. Input range: 0 to 9
PRINT DIRECTION	Set the print direction. STAND. / REVERSE
LABEL GAP	Set the label gap. Input range: 0 to 99.9
SENSOR TYPE	Set the sensor type. 0: NO USE / 1: LABEL / 2: MARK
PRINT SPEED	Set the print speed. Input range: 60 to 130

Menu name	Specification
BACK FEED	Select whether or not to set the back feed. NO/YES
SENSOR DISTANCE	Set the label sensor distance. Input range: 0 to 99.9
FEED LENGTH	Set the feed length. Input range: 0 to 99.9
PRE-STOP POS.	When printing the second line, feeding of the printed label is stopped and resumed again immediately when the pasting machine absorbs the label. This option sets the label feeding distance to the position from the edge of head front at the temporal stop of the label feeding. Input range: 0 to 99.9
(CONFIRM TO PRINT) FMT No.	Set the test print label format. Input range: 1 to 999
(CONFIRM TO PRINT) PLU No.	Set PLU No. to use for test printing. Input range: 00000000 to 99999999
(FORMAT INFO) WIDTH	Display the format width for the test print.
(FORMAT INFO) LENGTH	Display the format length for the test print.
CASSETTE No.	Display the cassette No. Only for display

4.9.3 LABEL COMB.(UPPER FIX)

Menu name	Specification
PRINTER	When the paste type is set to FIXED, display the printer to print the label. Move to the PRINTER SELECT screen.
FORMAT No.	When the paste type is set to FIXED, set the format to be used in the label printing. Input range: 1 to 999
CASSETTE No.	When the paste type is set to FIXED, set the cassette to use for label printing. Only printers including cassettes can be set.
MODIFY FORMAT	Move to the FORMAT EDIT screen to edit the selected format.

4.9.4 LABEL COMB. / DETAIL

LABEL COMB. / DETAIL						19-03-2014 (WED) 19:02	1/1
LABEL TYPE	PRINTER	FORMAT	CASSET.	LABEL PRINT		CONDITION	
NORMAL LABEL	PRINTER 1	52	1	YES	NO	NO CONDITION	
EYECATCH IMAGE LABEL	PRINTER 1	23	1	YES	NO	W/Eyecatch image	
EYECATCH PRICE LABEL	PRINTER 1	28	1	YES	NO	W/Campaign price	
CAMPAIGN COMMENT LABEL	PRINTER 1	0	1	YES	NO	W/Campaign comment	
CAMPAIGN ORIGIN LABEL	PRINTER 1	0	1	YES	NO	W/Campaign origin	
BARCODE LABEL	PRINTER 1	52	1	YES	NO	B LB: [BAR]	
INGREDIENTS ONLY LABEL	PRINTER 1	61	1	YES	NO	B LB: [INGREDIENTS]	
INGREDIENTS BARCODE LABEL	PRINTER 1	62	1	YES	NO	B LB: [INGREDIENTS]+[BA]	
TOTAL/SUBTTL	PRINTER 1	97	1	YES	NO	TOTAL/SUBTOTAL TOTAL/LABEL	

FORMAT EDIT

INITIAL

Menu name	Specification
PRINTER	Display the printer for label printing. Move to the PRINTER SELECT screen.
FORMAT	Set the format to be used in the label printing. Input range: 1 to 999
CASSET.	Display the cassette No. to be used in the label printing.
LABEL PRINT	Set whether or not to perform label printing when the label printing conditions are satisfied.
CONDITION	Move to the PRINT CONDITION SELECT screen (When the label group is "reversely pasted label, total label", the print condition cannot be changed.)
FORMAT EDIT	To edit the selected format, move to the FORMAT EDIT screen.
INITIAL	Initialize the printing pattern.

4.10 LABEL FORMAT

LABEL FORMAT				MAR.14.2014 (FRI) 12:12PM		1/4	
No.	DESCRIPTION	WIDTH (mm)	HEIGHT (mm)				
1		60.0	60.0				
2		60.0	80.0				
3		60.0	82.0				
4	USA	56.0	73.0				
5	USA	56.0	59.0				
6	USA COUPON	56.0	84.0				
7	USA NUTRITION	56.0	146.0				
11	USA	56.0	60.0				
12		80.0	60.0				
20	TRACEABILITY	56.0	73.0				

PRINT CONTROL
DETAIL
DELETE

Menu name	Specification
PRINT CONTROL	Open the PRINT CONTROL screen.
DETAIL	Move to the LABEL FORMAT/DETAIL (BASIC) screen.
DELETE	Return the selected format to the default status.
No.	Display the format No.
DESCRIPTION	Display the format title.
WIDTH	Set the format width. Input range: 0 to 800
HEIGHT	Set the format height. Input range: 0 to 2000

4.10.1 LABEL FORMAT / PRINT CONTROL

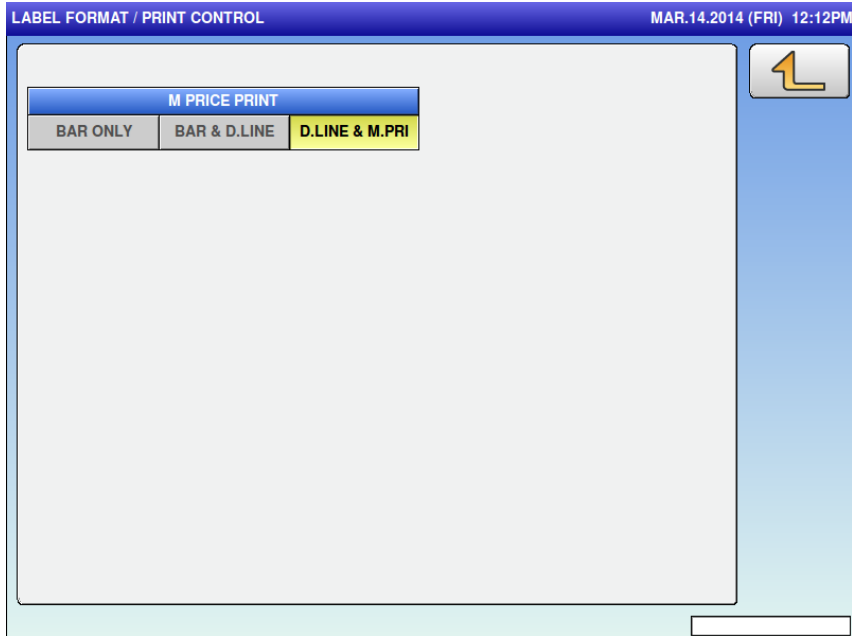

Menu name	Specification
M PRICE PRINT	Select the M price print. BAR ONLY / BAR & D.LINE / D.LINE & M.PRI

4.10.2 LABEL FORMAT / DETAIL (BASIC)

Menu name	Specification
FORMAT NAME	Touch the button to open the format name edit screen. Touch "<" and ">" located at both sides of the box to select the next (or previous) format master.
UNIT No.	Display the unit No. Touch the button to open the unit list set for the current format. The UNIT tab also has the same function.
UNIT NAME(ID)	Display the selected unit name. If nothing is selected, [HEADER] is selected.
PRINTER	Select the printer No.
PLU No.	Set the PLU No. to be used for the test print and preview. Input range: 1 to 99999999 For 0, print the checker label.
LABEL No.	Specify the label No. Input range: 1 to 99
WIDTH	Set the format width. Input range: 0 to 800
HEIGHT	Set the format height. Input range: 0 to 2000
Y-AXIS	Display the Y axis of selected unit. The axis is moved by entering the numerical number.

Menu name	Specification
FEED	Feed the label.
PRINT	Perform test printing by the format called and the item information set by PLU No.
UNIT ERASE	Delete the selected unit.
COPY	Enter the numerical number and press COPY to copy the said numerical number's format.
DELETE	Delete the format master. The dialog appears to ask whether to delete the format master.
←↑→↓	Move the axis of selected unit. If the HEADER is selected, the axis of whole format is moved.

4.10.3 LABEL FORMAT / DETAIL (UNIT)

LABEL FORMAT / DETAIL (UNIT) MAR.14.2014 (FRI) 8:05PM 1/1

1 < > STRING EDIT

UNIT No.	UNIT NAME	A	B	C	D	E	F
0	HEADER						

PLU	SET CONTENTS	VALUE
FORMAT No.	Header: 1-99 not able to change	1
X-AXIS	Able to set 0-08000 by 0.1mm	600
Y-AXIS	Able to set 0-2000 by 0.1mm	440
UNIT No.	Able to set 1-63	30
TURN	00:STANDARD 02:REVERSE	00

FEED PRINT UNIT ERASE UNIT COPY UNIT ADD

BASIC UNIT PREVIEW

Menu name	Specification
FORMAT NAME	Touch the button to open the format name edit screen. Touch "<" and ">" located at both sides of the box to select the next (or previous) format master.
STRING EDIT	Open the format string edit screen. Up to 526 bytes
UNIT No.	Display the unit No. Touch the button to open the unit list set for the current format. The UNIT tab also has the same function.
UNIT NAME(ID)	Display the selected unit name. If nothing is selected, "HEADER" is selected.
ABCDEF	Enter the alphabetical character. For hexadecimal entry
PLU	Display the name of set item.
SET CONTENTS	Display the set contents.
VALUE	Enter the value for set contents.
FEED	Feed the label.
PRINT	Perform test printing by the format being called and the item information set by [PLU No.]
UNIT ERASE	Delete the selected unit.
UNIT COPY	Enter the numerical number and press COPY to copy the said numerical number's format.

Menu name	Specification
UNIT ADD	Add the unit. The header unit also increases by one at the same time.

4.10.4 LABEL FORMAT / DETAIL (PREVIEW)



Menu name	Specification
DETAILED IMAGE /WHOLE IMAGE	Select the whole image or detailed image.
FEED	Feed the label.
PRINT	Perform test printing by the format called and the item information set by PLU No.
NORMAL	Set the label type to display. NORMAL / BARCODE / INGREDIENT / INGR.+BAR / SUBTOTAL / TOTAL
←↑→↓	Move the image. This function is enabled only for the detailed image.

4.11 BARCODE

4.11.1 BARCODE (POS FLAG)

BARCODE (POS FLAG) 07-03-2014 (FRI) 10:32

NON-PLU SET

EAN/UPC 13: 02

EAN/UPC 8: 2

PLU SET

10 DIGITS 13: 49

5 DIGITS 8: 49

POS FLAG POS CODE ITEM CODE

Menu name	Specification
EAN/UPC 13	Set the NON-PLU 13 digits. Input range: 00 to 99
EAN/UPC 8	Set the NON-PLU 8 digits. Input range: 0 to 9
10 DIGITS 13	Set the PLU 13 digits. Input range: 00 to 99
5 DIGITS 8	Set the PLU 8 digits. Input range: 00 to 99

4.11.2 BARCODE(POS CODE)

The screenshot shows a software interface for configuring barcode settings. The title bar reads 'BARCODE (POS CODE)' and the top right corner shows the date and time '07-03-2014 (FRI) 10:32'. The main area contains six menu items, each with a left arrow, a text field, and a right arrow:

- POS CODE TYPE**: 1: EAN/UPC 13
- OCR STYLE**: EAN13
- GS1 EXP FORMAT**: 1:(01)(3922)(3203)
- ITF FORMAT**: FFCCCCPPPPW5/Q5(C/D)
- POS FORMAT (WGT)**: FFCCCC(C/P)PPPP(C/D)
- POS FORMAT (FIX PRICE)**: FFCCCC(C/P)PPPP(C/D)

At the bottom of the screen, there are three buttons: 'POS FLAG', 'POS CODE', and 'ITEM CODE'. A small icon of a hand pointing to the top right is visible in the upper right corner of the main area.

Menu name	Specification
POS CODE TYPE	Select the POS code type. 1:EAN/UPC13 2:EAN/UPC 8/3:10 DIGITS 13/4:5DIGITS 8/5:GS1 6:GS1 ST/7:GS1 STO/8:GS1 LIMITED/9:GS1 EXPANDED/10:ITF
OCR	Select the POS code type. 1:EAN/UPC13 2:EAN/UPC 8/3:10 DIGITS 13/4:5DIGITS 8/5:GS1 6:GS1 ST/7:GS1 STO/8:GS1 LIMITED/9:GS1 EXPANDED/10:ITF
GS1 EXP FORMAT	Select the GS1 EXP format. 1:(01)(3922)(3203) / 2:(01)(3922)(3203)(15)
ITF FORMAT	Set the format when POS CODE TYPE is [ITF].
POS FORMAT(WGT)	Select the POS format (weight). Touch the button to open the POS FORMAT list. Select the format from the list.
POS FORMAT (FIX PRICE)	Select the POS format (fix price). Touch the button to open the POS FORMAT list. Select the format from the list.

4.11.3 BARCODE (ITEM CODE)

BARCODE (ITEM CODE) 07-03-2014 (FRI) 10:32

DEPARTMENT No. DIGIT SET

1	2	3	4	5	6	7	8
---	---	---	---	---	---	---	---

GROUP No. DIGIT SET

1	2	3	4	5	6	7	8
---	---	---	---	---	---	---	---

EAN/UPC 13 DIGIT SET

1	2	3	4	5	6	7	8
---	---	---	---	---	---	---	---

EAN/UPC 8 DIGIT SET

1	2	3	4	5	6	7	8
---	---	---	---	---	---	---	---

POS FLAG POS CODE ITEM CODE

Menu name	Specification
DEPARTMENT No. DIGIT SET	<p>Execute the digit set of department No.</p> <p>Press the numerical number to switch the selection.</p> <p>Press the numerical number in series.</p> <p>(e.g. The combination of "1" and "3" cannot be selected. The combination of "1", "2" and "3" can be selected.)</p>
GROUP No. DIGIT SET	<p>Execute the digit set of group No.</p> <p>Press the numerical number to switch the selection.</p> <p>Press the numerical number in series.</p> <p>(e.g. The combination of "1" and "3" cannot be selected. The combination of "1", "2" and "3" can be selected.)</p>
EAN/UPC 13 DIGIT SET	<p>Execute the digit set of JAN code (13 digits).</p> <p>Press the numerical number to switch the selection.</p> <p>Press the numerical number in series.</p> <p>(e.g. The combination of "1" and "3" cannot be selected. The combination of "1", "2" and "3" can be selected.)</p>
EAN/UPC 8 DIGIT SET	<p>Execute the digit set of JAN code (8 digits).</p> <p>Press the numerical number to switch the selection.</p> <p>Press the numerical number in series.</p> <p>(e.g. The combination of "1" and "3" cannot be selected. The combination of "1", "2" and "3" can be selected.)</p>

4.12 CUSTOM BARCODE

The screenshot shows the 'CUSTOM BARCODE' screen with a blue header bar containing the title, date 'MAR.14.2014 (FRI) 10:21AM', and page number '1/1'. The main area is a list with two items: '1 MEAT' (highlighted in yellow) and '2 FISH'. Below the list are several empty rows. On the right side, there are buttons for 'ITEMS', '10 ITEMS', 'DETAIL', and 'DELETE'. At the bottom, there is a 'SEARCH TEXT' input field and a 'SEARCH' button.

Menu name	Specification
ITEMS	Switch the display items between "10 items" and "20 items".
DETAIL	Move to the CUSTOM BARCODE (BASIC) screen, and display the details of custom bar code in selection.
DELETE	Delete the selected line.
SEARCH TEXT	<p>Move to the CUSTOM BARCODE / SEARCH TEXT EDIT screen.</p> <p>The screenshot shows the 'CUSTOM BARCODE / SEARCH TEXT EDIT' screen with a search text input field and a keyboard. The keyboard has a numeric row (1-0), a QWERTY row, an ASDFGHJKL row, a ZXCVBNM row, and a row with special characters like '#', '%', '&', 'New Line', 'Line Delete', 'Char Delete', and 'Back Space'. Below the keyboard is a table with columns 'No.', 'CHAR', and 'REMAIN', and a row with values '1', '000', and '254'. There are also 'COPY' and 'ERASE' buttons.</p>
SEARCH	<p>Switch the search condition between [SEARCH] and [CANCEL].</p> <p>SEARCH: Display data including [SEARCH TEXT] in a list. CANCEL: Display all the data in a list.</p>

4.12.1 CUSTOM BARCODE (BASIC)

CUSTOM BARCODE (BASIC) MAR.14.2014 (FRI) 10:24AM 1/1

1 < MEAT >

No.	ID	START	DIGIT	DATA	CTRL
1	PLU No.	1	0:ALL	00000001	0:NONE
2	POS CODE	1	0:ALL	0000000000	0:NONE
3	SELL-BY DATE	1	0:ALL	20140315	0:NONE
4					

PLU 1
FORMAT 1
FORMAT EDIT
INSERT
DELETE

BASIC PREVIEW

Menu name	Specification
PLU	Set the item No. to be used for the preview. Input range: 1 to 99999999 Other tabs also have the same function.
FORMAT	Input range: 1 to 999 Other tabs also have the same function.
FORMAT EDIT	Open the format edit screen. Other tabs also have the same function.
INSERT	Insert the blank line in front of selected line.
DELETE	Delete the selected line.
No.	Touch the button to switch the selection.
ID	Set the ID to be combined. Touch the button to open the CUSTOM BARCODE ID LIST. Select the ID from the list.
START	Set the start digit. Input range: 1 to 999
DIGIT	Set the digit number. 0:ALL or 1 to 999
DATA	Display the set ID data. Touch the button to open the edit screen only when the ID is set to PRE PRINT.

Menu name	Specification
CTRL	Select the control character. 0: NONE 1: ()

4.12.2 CUSTOM BARCODE (PREVIEW)

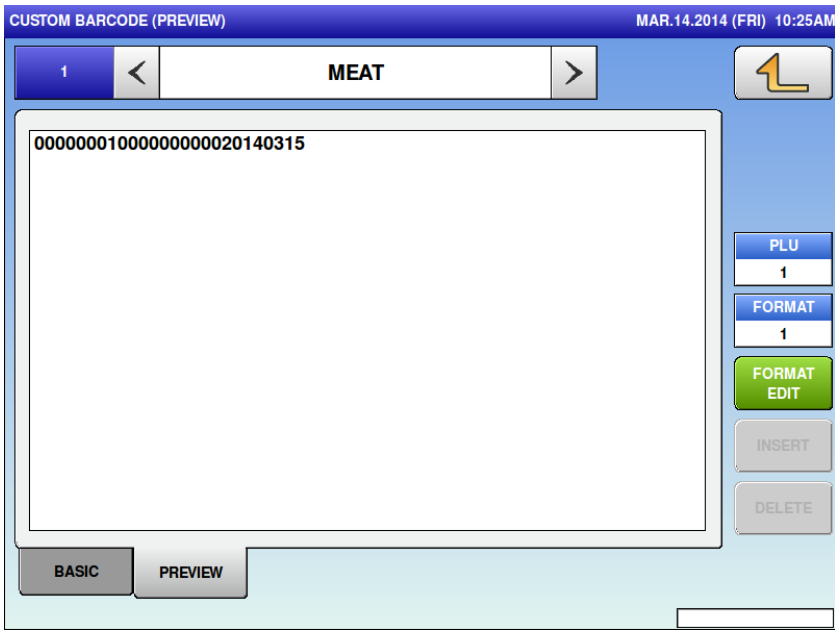

Menu name	Specification
	The combined-barcode preview is displayed only.

4.13 MENU TITLE

4.13.1 MENU TITLE (OPERATE)

No.	DEFAULT NAME	NEW NAME
1001	PREPACK	PREPACK
1003	ACC1	ACC1
1004	ACC2	ACC2
1005	ACC3	ACC3
1002	TOTAL ADJUST	TOTAL ADJUST

OPERATE TOTAL PROGRAM SETUP ADJUST

EDIT

Menu name	Specification
DEFAULT NAME	Display the menu name before editing. Touch the button to select the menu name.
NEW NAME	Display the menu name after editing. Touch the button to select the menu name.
EDIT	Transfer to the edit screen of the selected menu name.

(All tabs have the same operations so their explanations are omitted here.)

4.14 OPERATION SETTING

4.14.1 OPERATION SETTING (CALL1)

OPERATION SETTING (CALL1) 12-03-2014 (WED) 17:10

FIND PLU

START CHAR.	LINE1	LINE2	ALL
-------------	-------	-------	-----

FREEMASTER FOR URL
15

PACK MODE HOLD	TORQUE WRAPPING PLU
FIXING	0
ITEM EACH	

CALL1 CALL2 PROD. PRINT

Menu name	Specification
FIND PLU	Select how to search PLU. START CHAR. / LINE1 / LINE2 / ALL
FREEMASTER FOR URL	Set the freemaster No. to use in the URL. Input range: 0 to 15
PACK MODE HOLD	Select the PACK mode between "fixed to scale" or "set by item". FIXING / ITEM EACH
TORQUE WRAPPING PLU	Set the PLU No. to be used in the torque wrapping. Input range: 0 to 99999999

4.14.2 OPERATION SETTING (CALL2)

OPERATION SETTING (CALL2) 12-03-2014 (WED) 17:10

CALL UP UNIT PRICE

EVERY U/P No. 1 LAST CALL UP U/P

CHANGE MASTER

BARCODE TYPE POS REFERENCE POS FLAG BARCODE POS FORMAT(WGT)	POP MSG. PLU U/P	FEED SPEED PLU U/P
PLU U/P	REG. CODE PLU U/P	PASTE MODE PLU U/P
IMAGE 1 PLU U/P	IMAGE 2 PLU U/P	IMAGE 3 PLU U/P
EXTRA MSG. 1 PLU U/P	INGREDIENT PLU U/P	EXTRA MSG. 3 PLU U/P

CALL1 CALL2 PROD. PRINT

Menu name	Specification
CALL UP UNIT PRICE	Select and set the unit price to be set in the PLU calling. EVERY U/P No.1: 1 is selected for the unit price. LAST CALL UP U/P: the unit No. used latest is selected.
CHANGE MASTER	Select and set the method to be used for each item. PLU: Data permanently set to unit 1 is used. U/P: Data set for each unit is used.

4.14.3 OPERATION SETTING (PROD.)

OPERATION SETTING (PROD.) MAR.13.2014 (THU) 4:53PM

WEIGHTED ITEMS' WEIGHT RANGES CHECK

NO
YES

TARE SELECT

1st TARE
2nd TARE

FIX PRICE ITEMS' WEIGHT RANGES CHECK

NO
YES

@for SET

NO
YES

END OF DAY

16

MEAT CUT TEST

NO
YES

FIX UPR POP UP

NO
YES

MEAT CUT TEST DEL. SELECT

NON USE
USE

CALL1
CALL2
PROD.
PRINT

Menu name	Specification
WEIGHED ITEMS'WEIGHT RANGES CHECK	Select whether or not to check the weight of weighed items. NO / YES
TARE SELECT	Select the tare. 1st TARE / 2nd Tare
FIX PRICE ITEMS' WEIGHT RANGES CHECK	Select whether or not to check the weight of fixed-price product. NO / YES
@for SET	Select and set whether to perform @for calculation (for the fixed price item using "x (MULTI)" key) . *Settable only when the country is set to [USA] NO / YES
END OF DAY	Set the time valid for the next day process set for PLU. Input range: 0 to 23
MEAT CUT TEST	Select and set whether to use the Meat Cut Weight Control mode. NO / YES
FIX UPR POP UP	In calling the fixed price item, select and set whether to display the popup display for fixed weight setting. NO / YES
MEAT CUT TEST DEL. SELECT	Select and set whether to use the DELETE button in the Meat Cut Master Setting screen. NON USE / USE

4.14.4 OPERATION SETTING (PRINT.)

OPERATION SETTING (PRINT) 25-04-2014 (FRI) 9:31

ORDER COMPRECACTION SETUP			AUTO SUBTOTAL LABEL		
NONE	BUZZER	MESSAGE	NONE	1	2
TARGET AUTO SETUP			AUTO/MANUAL		
NONE	YES		AUTO	MANUAL	
SUBTOTAL CLEAR			UPPER BAR WHEN UNDER LABEL PRINT		
SUBTOTAL PRINT	PLU CALL		NO PRINT	PRINT	

CALL1 CALL2 PROD. PRINT

Menu name	Specification
ORDER COMPRECACTION SETUP	Select and set the operation when the order is completed. NONE / BUZZER / MESSAGE
AUTO SUBTOTAL LABEL	Select printing of the automatic subtotal label. NONE: Printing is not performed. 1: 1 sheet of subtotal label is printed. 2: 2 sheets of subtotal label are printed. Settable only when the order completion operation selects [MESSAGE].
TARGET AUTO SETUP	Selecting YES sets the same target No. when the target No. setting is completed.
SUBTOTAL CLEAR	Select and set the clear timing of the subtotal data. SUBTOTAL PRINT: Cleared when the subtotal is printed PLU CALL: Cleared when the item is called
AUTO/MANUAL	Select and set the initial value of [PRN MD.] when the screen is moved to OPERATE MODE.
UPPER BAR WHEN UNDER LABEL PRINT	Select and select whether to print the barcode of the 1st LABEL when the 2nd LABEL is printed.

4.15 ERROR PROCESS

4.15.1 ERROR PROCESS (ISSUE)

ERROR PROCESS (ISSUE) 07-03-2014 (FRI) 16:06

PRINTING AT €0 PRICE

BARCODE=0 No PRICE
 No BAR. PRICE=0
 No BAR. No PRICE

DISPLAY ERROR: TARE WEIGHT NOT SET

NO
 YES

DISPLAY ERROR: ZERO (€ 0) PRICE

NO
 YES

PLU NAME LINES OVER ERROR

ERROR
 LINE CUT

Menu name	Specification
PRINTING AT 0 PRICE	Select the action of printing at 0. BARCODE=0 No PRICE / No BAR.PRICE=0 / No BAR. No PRICE The currency unit depends on the country master.
DISPLAY ERROR: TARE WEIGHT NOT SET	Select whether or not to display the error message when the tare weight is not set. NO / YES
DISPLAY ERROR: ZERO PRICE	Select whether or not to display the error message of 0 price. NO / YES
PLU NAME LINES OVER ERROR	Select and set the process when the item line No. is over the set number. ERROR: Display the LINE OVER error, and no item is printed. LINE CUT: Cut the exceeded line, and the item is printed within the display range.

4.15.2 ERROR PROCESS (CALL)

ERROR PROCESS (CALL) APR.21.2014 (MON) 7:36PM

NO POS CODE SET ERROR

NO ERROR DISPLAY
 NO LABEL PRINT
 NO BAR PRINT

ERROR PROCESS

EXTRA MSG.1	INGREDIENT	EXTRA MSG.3	COUPON MSG.
<input type="checkbox"/> NO <input checked="" type="checkbox"/> YES	<input type="checkbox"/> NO <input checked="" type="checkbox"/> YES	<input type="checkbox"/> NO <input checked="" type="checkbox"/> YES	<input type="checkbox"/> NO <input checked="" type="checkbox"/> YES
POP MSG.	FREE MSG.1	FREE MSG.2	FREE MSG.3
<input type="checkbox"/> NO <input checked="" type="checkbox"/> YES	<input type="checkbox"/> NO <input checked="" type="checkbox"/> YES	<input type="checkbox"/> NO <input checked="" type="checkbox"/> YES	<input type="checkbox"/> NO <input checked="" type="checkbox"/> YES
FREE MSG.4	FREE MSG.5	FREE MSG.6	FREE MSG.7
<input type="checkbox"/> NO <input checked="" type="checkbox"/> YES	<input type="checkbox"/> NO <input checked="" type="checkbox"/> YES	<input type="checkbox"/> NO <input checked="" type="checkbox"/> YES	<input type="checkbox"/> NO <input checked="" type="checkbox"/> YES
FREE MSG.8	FREE MSG.9	FREE MSG.10	FREE MSG.11
<input type="checkbox"/> NO <input checked="" type="checkbox"/> YES	<input type="checkbox"/> NO <input checked="" type="checkbox"/> YES	<input type="checkbox"/> NO <input checked="" type="checkbox"/> YES	<input type="checkbox"/> NO <input checked="" type="checkbox"/> YES
FREE MSG.12	FREE MSG.13	FREE MSG.14	FREE MSG.15
<input type="checkbox"/> NO <input checked="" type="checkbox"/> YES	<input type="checkbox"/> NO <input checked="" type="checkbox"/> YES	<input type="checkbox"/> NO <input checked="" type="checkbox"/> YES	<input type="checkbox"/> NO <input checked="" type="checkbox"/> YES

Menu name	Specification
NO POS CODE SET ERROR	Select the action when the POS code is not set. NO ERROR DISPLAY / NO LABEL PRINT / NO BAR PRINT
ERROR PROCESS	Set the error display operation when the link master at item calling does not exist. NO / YES

4.15.3 ERROR PROCESS (COMMON)

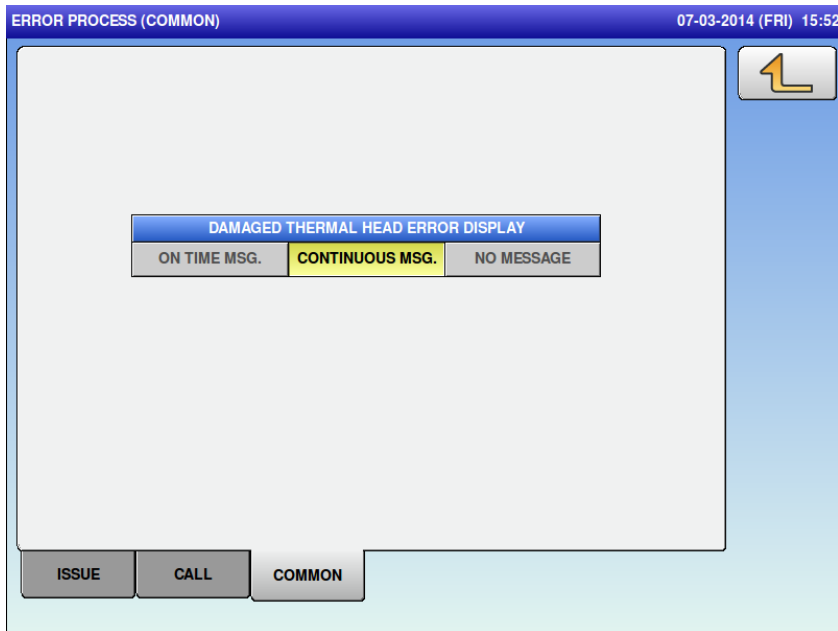

Menu name	Specification
DAMAGED THERMAL HEAD ERROR DISPLAY	Select how to set the error message of damaged thermal head. ON TIME MSG / CONTINUOUS MSG / NO MESSAGE

4.16 ERROR LOG

4.16.1 ERROR LOG (DISPLAY)

ERROR LOG (DISPLAY)					13-03-2014 (THU) 17:37	1/25
DATE/TIME	ERROR No.	PLU	TRAY	ERROR DESCRIPTION		
03/13 17:30:35	0459-0000	0	0	MACHINE IS RETURNING TO STAND BY POSITION		
03/13 17:30:35	0322-0000	0	0	GO BACK TO ORIGINAL POSITION		
03/13 17:30:28	0801-0001	0	0	CAN NOT COMMUNICATE WITH PRINTER 2		
03/13 17:30:24	0361-0000	0	0	POWER IS ON		
03/13 17:27:28	19006-0000	20140313	0	POWER OFF		
03/13 17:27:00	0459-0000	0	3	MACHINE IS RETURNING TO STAND BY POSITION		
03/13 17:12:21	0459-0000	0	0	MACHINE IS RETURNING TO STAND BY POSITION	LOG LEVEL	
03/13 17:12:20	0322-0000	0	0	GO BACK TO ORIGINAL POSITION	ERR.+OPE.	
03/13 17:12:00	0801-0001	0	0	CAN NOT COMMUNICATE WITH PRINTER 2		
03/13 17:11:56	0361-0000	0	0	POWER IS ON		

DISPLAY DELETE

Menu name	Specification
LOG LEVEL	Select the error log level to be displayed on the list. ONLY ERR. / ERR.+OPE.
DELETE	Delete the error log. The DELETE CHECK dialog appears to ask whether to delete the error log.

4.17 TRACE.

Menu name	Specification
TRACEABILITY TYPE	Select the traceability type. TYPE1 / TYPE2 (TYPE1 is simple traceability.)
TRACEABILITY TOTAL	Select whether or not to add the traceability total. NO / YES
TRACE. DATA DELETE	Select the manual or auto deletion of traceability data. MANUAL / AUTO
TRACEABILITY PASSWORD	Set the traceability password. This function is enabled when [TYPE2] is selected in the TRACEABILITY TYPE. 0 or 4-digit number
LOOKUP TABLE EDIT	Select whether or not to enable the lookup table edit on the traceability screen in the normal mode. NO / YES

4.18 DUAL CURRENCY

DUAL CURRENCY 10-03-2014 (MON) 15:31

EXCH. RATE 4293	EXCH. RATE DEC. PNT. POS. 4
PERIOD SELECTION	
LOCAL+FOREIGN	FOREIGN+LOCAL LOCAL FOREIGN
LOCAL CURRENCY SYMBOL Lm	LOCAL CURR. DEC. PNT. POS. 3

Menu name	Specification
EXCH. RATE	Set the exchange rate of the second currency. Input range: 0 to 99999999
EXCH. RATE DEC. PNT. POS.	Set the decimal point position of the exchange rate of the second currency. Input range: 0 to 7
PERIOD SELECTION	Select the currency combination. LOCAL+FOREIGN/FOREIGN+LOCAL/LOCAL/FOREIGN
LOCAL CURRENCY SYMBOL	Set the local currency symbol. Up to 3 bytes
LOCAL CURR. DEC. PNT. POS.	Set the decimal point position of the local currency. Input range: 0 to 7

4.19 PRICE ROUNDING

PRICE ROUNDING 10-03-2014 (MON) 20:19

The screenshot shows a software interface for configuring price and discount rounding. It features two main sections: 'PRICE ROUNDING' and 'DISCOUNT ROUNDING'. In the 'PRICE ROUNDING' section, the '4/5' option is selected. In the 'DISCOUNT ROUNDING' section, the 'DOWN' option is selected. The interface includes a title bar with the text 'PRICE ROUNDING' and a timestamp '10-03-2014 (MON) 20:19'. A yellow arrow icon is located in the top right corner of the main content area.

Menu name	Specification
PRICE ROUNDING	Select the price rounding type. 4/5 / 05
DISCOUNT ROUNDING	Select the discount rounding type. DOWN / 4/5 / UP

4.20 FREQUENT SHOPPER

The screenshot shows a software interface for 'FREQUENT SHOPPER'. At the top, the title bar reads 'FREQUENT SHOPPER' and the system clock shows '11-03-2014 (TUE) 8:50'. The main area contains two configuration sections. The first section, 'BARCODE PRICE TYPE', has two buttons: 'NORMAL' and 'MARKDOWN', with 'MARKDOWN' highlighted in yellow. The second section, 'LOGO IMAGE 1 No.', has a text input field containing the number '000'. A yellow arrow icon is located in the top right corner of the main area.

Menu name	Specification
BARCODE PRICE TYPE	Select the barcode price type. NORMAL / MARKDOWN
LOGO IMAGE 1 No.	Set the logo image 1 No. Input range: 0 to 999

4.21 STANDBY MODE

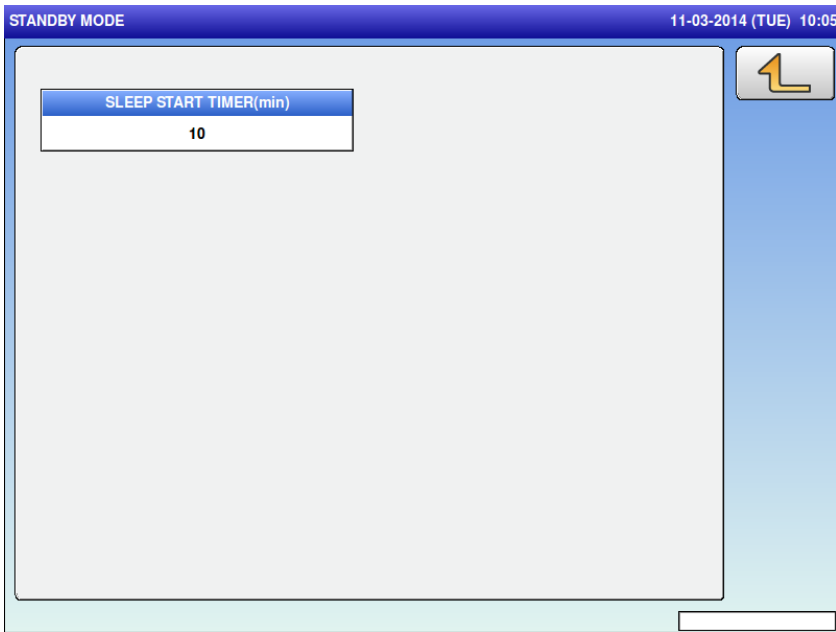

Menu name	Specification
SLEEP START TIMER(min)	Set the time to standby mode. The unit is in minutes.

4.22 COUNTRY

Menu name	Specification																		
COUNTRY	<p>Select the country.</p> <p>Enter 951753 and press PLU to enable this function.</p> <p>Touch the COUNTRY button to open the list and select the country.</p>																		
LANGUAGE	<p>Set the first to third language.</p> <p>Touch the button to open the list and select the language.</p> <table border="1"> <tbody> <tr><td>1</td><td>ENGLISH</td></tr> <tr><td>2</td><td>FRENCH</td></tr> <tr><td>3</td><td>GERMAN</td></tr> <tr><td>4</td><td>ITALIAN</td></tr> <tr><td>5</td><td>DUTCH</td></tr> <tr><td>6</td><td>SPANISH</td></tr> <tr><td>7</td><td>ENGLISH(SOUTH AFRICA)</td></tr> <tr><td>8</td><td>SWEDISH</td></tr> <tr><td>9</td><td>FINNISH</td></tr> </tbody> </table>	1	ENGLISH	2	FRENCH	3	GERMAN	4	ITALIAN	5	DUTCH	6	SPANISH	7	ENGLISH(SOUTH AFRICA)	8	SWEDISH	9	FINNISH
1	ENGLISH																		
2	FRENCH																		
3	GERMAN																		
4	ITALIAN																		
5	DUTCH																		
6	SPANISH																		
7	ENGLISH(SOUTH AFRICA)																		
8	SWEDISH																		
9	FINNISH																		
DETAIL	<p>Transfer to the country setting details screen.</p> <p>Enter 495344 and press PLU to open the screen.</p>																		

4.22.1 COUNTRY / DETAIL (CURRENCY)

COUNTRY / DETAIL (CURRENCY) 11-03-2014 (TUE) 12:03

INIT.

CURRENCY WEIGHT DATE

Menu name	Specification
CURRENCY SYMBOL	Set the currency symbol. Up to 3 bytes
DEC. POINT POSITION	Set the decimal point position of currency. Input range: 0 to 7
DEC. POINT TYPE	Select the decimal point type. . / , (dot / comma)
TEMPERATURE	Select and set the temperature unit. °C / F
INIT.	Initialize the set value of country master. Other tabs also have the same function.

4.22.2 COUNTRY / DETAIL (WEIGHT)

COUNTRY / DETAIL (WEIGHT) 11-03-2014 (TUE) 16:43

WEIGHT UNIT			MAX. TARE		
lb	kg	g	5998		
DEC. POINT POSITION			MINIMUM PRINT WGT		
3			20e	5e	3e
DEC. POINT TYPE					
.			,		

INIT.

CURRENCY WEIGHT DATE

Menu name	Specification
WEIGHT UNIT	Select the weight unit. Lb / kg / g Enter 14789632 and press PLU to enable this function.
MAX. TARE	Set the maximum tare. For the unit of kg or g: 0 to 5998 For the unit of lb: 0 to 9990 Enter 14789632 and press PLU to enable this function.
DEC. POINT POSITION	Set the decimal point position. Input range: 1 to 5 Enter 951753 and press PLU to enable this function.
DEC. POINT TYPE	Select the decimal point type. . / , (dot / comma) Enter 951753 and press PLU to enable this function.
MINIMUM PRINT WGT	Set the minimum print weight. 20e / 5e / 3e Enter 951753 and press PLU to enable this function. This function is enabled only for the manual print.
INIT.	Initialize the set value of country master. Other tabs also have the same function.

4.22.3 COUNTRY / DETAIL (DATE)

COUNTRY / DETAIL (DATE) 11-03-2014 (TUE) 12:03

DATE FORMAT: 2:D-M-Y

DATE SPACER: , . : / SPC ymd -

YEAR TYPE: YY(2) YYYY(4)

SHELF LIFE-USE BY: Next Day Today

MONTH TYPE: DIGIT CHAR.(3) CHAR.(2)

INIT.

CURRENCY WEIGHT DATE

Menu name	Specification
DATE FORMAT	Select the date format (order). 0:Y-M-D / 1:M-D-Y / 2:D-M-Y
YEAR TYPE	Select the year type. YY(2) / YYYY(4) Last 2 or 4 digits
MONTH TYPE	Select the month type. DIGIT / CHAR(3) / CHAR(2) Numerical number, three characters or two characters
DATE SPACER	Select the date spacer. ,(comma) / .(period) / :(colon) / /(slash) / space / ymd / • (middle point)
SHELF LIFE-USE BY	Select whether or not to set the shelf life "1" to the next day or today. Next Day / Today
INIT.	Initialize the set value of country master. Other tabs also have the same function.

4.23 FILE SAVE /LOAD

4.23.1 FILE SAVE/LOAD (USB>SCALE)

MASTER NAME	NUMBER
PLU	4
STORE	2
FIX PRICE SYMBOL	20
PRESET KEY (LCD)	65
FORMAT	2
LABEL	7
CASSETTE	25

FILES SAVED ON USB

USB > SCALE SCALE > USB USB DATA DEL. SCALE INIT.

Menu name	Specification
INPUT SOURCE	Display the name of the input source.
INPUT SELECT	Open the FILE SAVE/LOAD IN SELECT screen. The input source is listed only when the files are saved on the USB flash drive.
MASTER NAME	Display the master name. Touch the button to change the selection. Other tabs also have the same function.
NUMBER	Display the number of master data. Other tabs also have the same function.
ALL SEL.	Change the selections of all masters. This function is enabled when the input source file is set. Other tabs also have the same function.
DETAIL	Open the FILE SAVE/LOAD OUT (DETAIL) screen. Other tabs also have the same function.
EXEC	Execute the file input of selected master. The INPUT CHECK dialog appears to ask whether to input the file.

4.23.2 FILE SAVE/LOAD (SCALE>USB)

FILE SAVE/LOAD (SCALE > USB) 12-03-2014 (WED) 11:02 1/9

OUT SOURCE DATA 1 OUTPUT SELECT

MASTER NAME	NUMBER
PLU	4
STORE	2
FIX PRICE SYMBOL	20
FREE MSG.1	0
FREE MSG.2	0
FREE MSG.3	0
FREE MSG.4	0

ALL SEL. DETAIL EXEC

USB > SCALE SCALE > USB USB DATA DEL. SCALE INIT.

Menu name	Specification
OUT SOURCE	Display the name of the output source.
OUTPUT SELECT	Open the FILE SAVE/LOAD OUT SELECT screen. SET: Set the output source. EDIT: Edit the name of the output source.
ALL SEL.	Switch between "All items selected" / "All items unselected".
DETAIL	Move to the FILE SAVE/LOAD / DETAIL screen.
EXEC	Execute the file output of selected master. The OUTPUT CHECK dialog appears to ask whether to output the file.

■ FILE SAVE/LOAD / OUTPUT SELECT

FILE SAVE/LOAD / OUTPUT SELECT		12-03-2014 (WED) 11:02	1/1
No.	INPUT	 EDIT SET	
1	DATA 1		
2			
3			
4			
5			
6			
7			
8			
9			
10			

Menu name	Specification
No.	Display the folder No. displayed in the USB memory. Folder "Data01" to "Data10" = №1 to №10
INPUT	Display the data name (index name) named to each master file group "Data01" to "Data10" memorized in the USB memory.
EDIT	Move to the FILE SAVE/LOAD / OUTPUT SELECT / EDIT INDEX NAME screen.
SET	Determine the input source selected, and return to the previous screen.

4.23.3 FILE SAVE/LOAD (USB DATA DEL.)

FILE SAVE/LOAD (USB DATA DEL.) 12-03-2014 (WED) 11:06 1/4

DELETE SOURCE DATA 1 DELETE SELECT

MASTER NAME	NUMBER
PLU	4
STORE	2
FIX PRICE SYMBOL	20
PRESET KEY (LCD)	65
FORMAT	2
LABEL	7
CASSETTE	25

ALL SEL. DETAIL EXEC

USB > SCALE SCALE > USB USB DATA DEL. SCALE INIT.

Menu name	Specification
DELETE SELECT	Display the name of the deletion source.
MASTER NAME	Display the master name of the file in the folder of USB memory specified as "Deletion destination".
ALL SEL.	Switch between "All items selected" / "All items unselected".
EXEC	Execute the file output of selected master. The OUTPUT CHECK dialog appears to ask whether to output the file.

■ FILE SAVE/LOAD / DELETE SELECT

FILE SAVE/LOAD / DELETE SELECT		12-03-2014 (WED) 11:03	1/1
No.	INPUT		
1	DATA 1	 ALL DEL ERASE SET	
2			
3			
4			
5			
6			
7			
8			
9			
10			

Menu name	Specification
No.	Display the folder No. memorized in the USB memory. Folder "Data01" to "Data10" = No.1 to No.10
INPUT	Display the data name (index name) named to each master file group "Data01" to "Data10" memorized in the USB memory.
ALL DEL	Delete all the files in the USB memory (folders "Data01" to "Data10").
ERASE	Delete all the files in the selected data folder.
SET	Determine the input source selected, and return to the previous screen.

4.23.4 FILE SAVE/LOAD (SCALE INIT.)

FILE SAVE/LOAD (SCALE INIT.) 12-03-2014 (WED) 11:06 1/9

DATA INTERNAL MASTER

MASTER NAME	NUMBER
PLU	4 (4)
STORE	2
FIX PRICE SYMBOL	20
FREE MSG.1	0
FREE MSG.2	0
FREE MSG.3	0
FREE MSG.4	0

MEMORY SPACE
1,547,860 KB

PLU MASTER CONV.
1763079 EA

ALL SEL.

DETAIL

EXEC

USB > SCALE SCALE > USB USB DATA DEL. SCALE INIT.

Menu name	Specification
DATA	Display the master name. Touch the button to change the selection.
MASTER NAME	Display the master name in the scale. Line selection/deselection is available.
NUMBER	Display the data No. of the master inside the scale.
MEMORY SPACE	Display the memory space inside the scale in kilobyte (kB).
PLU MASTER CONV.	Display the approximate value about how many items master can store in the free space.
ALL SEL.	Switch between "All items selected" / "All items unselected".
EXEC	Initialize the selected master. The INITIALIZATION CHECK dialog appears to ask whether to initialize the master.

4.23.5 FILE SAVE/LOAD / DETAIL

FILE SAVE/LOAD / DETAIL 12-03-2014 (WED) 16:26

The screenshot shows a software interface with a blue header bar containing the text 'FILE SAVE/LOAD / DETAIL' on the left and '12-03-2014 (WED) 16:26' on the right. Below the header is a large white area with a light blue border. On the right side of this area is a vertical blue bar with a yellow 'L' icon at the top. The main content area contains four menu items, each with a blue title bar and two options in a white box with a yellow highlight for the selected option:

- RENEW CONTROL**: Options are 'NO' (selected) and 'YES'.
- TRAY LIMIT**: Options are 'LIMIT' and 'NON LIMIT' (selected).
- CHARACTERS OUT TYPE**: Options are 'CONTROL CODE NO' and 'CONTROL CODE YES' (selected).
- INPUT MODE**: Options are 'CHANGE' (selected) and 'ADDITION'.

Menu name	Specification
RENEW CONTROL	Select whether or not to control update. NO / YES
TRAY LIMIT	Select whether or not to limit the tray. LIMIT / NO LIMIT
CHARACTERS OUT TYPE	Select the characters output type. CONTROL CODE NO / CONTROL CODE YES [CONTROL CODE NO] cannot be selected.
INPUT MODE	Select the input mode. CHANGE / ADDITION

Chapter 5 Adjust Mode

5.1 Startup

Turn on the power.



The PREPACK screen in the OPERATE mode appears.

Press  at the upper right side of the screen.



The menu appears in the OPERATE MODE.

Press the [ADJUST] button on the screen.

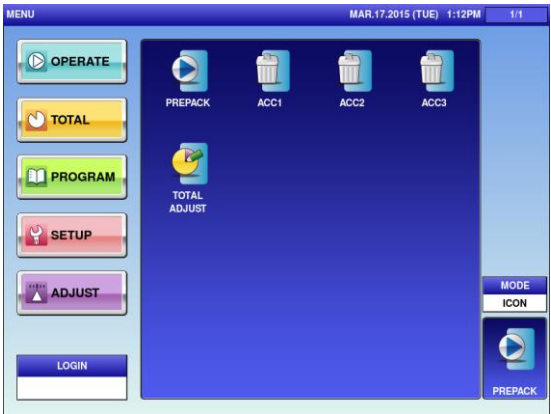

The User Menu screen in the ADJUST mode appears.

Input the password “495344” using the numerical keys, and press the [LOGIN] button on the screen.

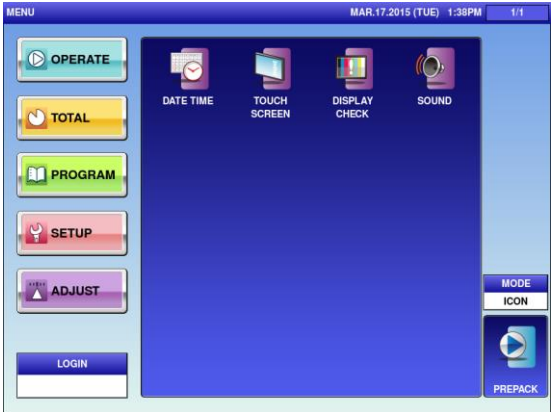



The Maintenance Menu screen appears in the ADJUST mode.

To log out, enter nothing or enter “0” and press the [LOGIN] button.

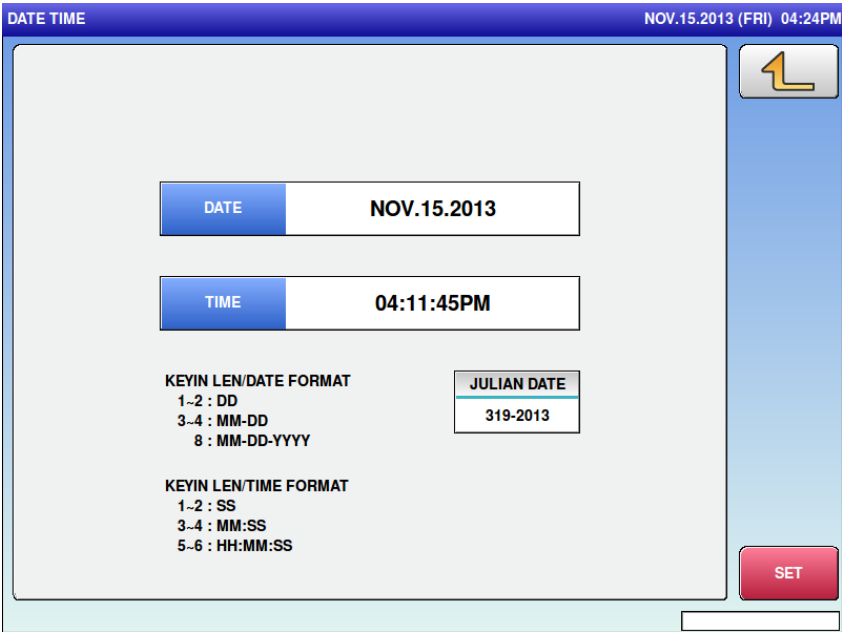

5.2 DATE TIME

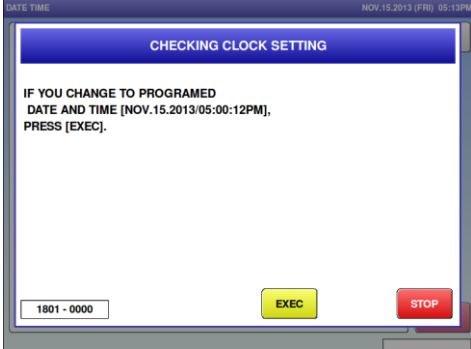

Menu name	Specification
	<p>Return to Menu. When any change is made, save the setting (with confirmation message).</p> 
DATE	<p>Enter the date conforming to KEYIN LEN/DATE FORMAT.</p> <p>If "21022013" is entered, "21-02-2013" is displayed. If "20" is entered, "20-02-2013" is displayed. If "2003" is entered, "20-03-2013" is displayed.</p>
TIME	<p>Enter the time conforming to KEYIN LEN/TIME FORMAT.</p> <p>If "00" is entered, "17:53:00" is displayed. If "2000" is entered, "17:20:00" is displayed. If "152000" is entered, "15:20:00" is displayed.</p>
JULIAN DATE	<p>Display the number of days counted from January 1.</p>
TIME ZONE	<p>Set the time zone. When pressing this button without numeric value, the time zone list is displayed according to country setting. When pressing it with 495344 entered, the entire time zone list is displayed.</p>

	
SET	<p>Set the entered date and time.</p> <p>The CHECKING CLOCK SETTING dialog appears to ask whether to change the date and time.</p>

5.3 TOUCH SCREEN

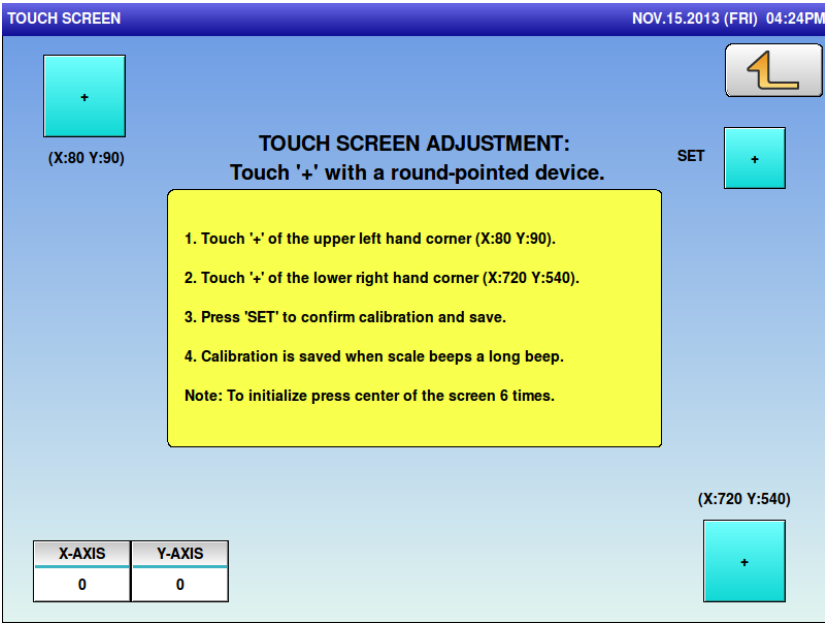

Menu name	Specification
	For initialization of touch panel, press center of the screen 6 times.

5.4 DISPLAY CHECK

● HORIZONTAL screen

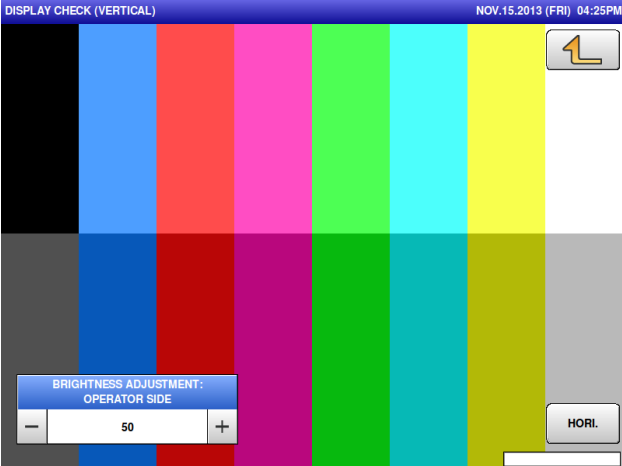

● VERTICAL screen

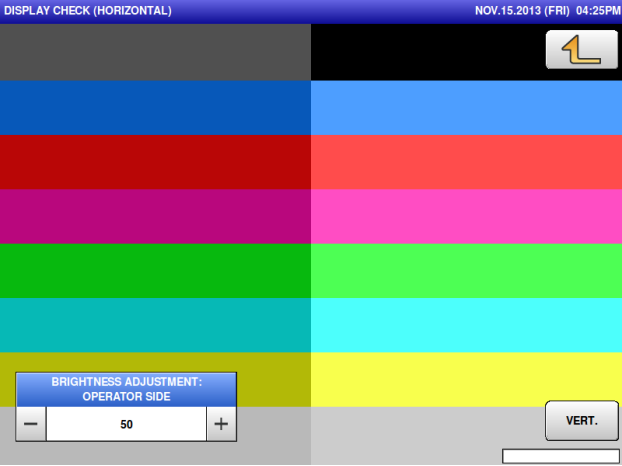

Menu name	Specification
BRIGHTNESS ADJUSTMENT: CUSTOMER SIDE	Adjust the brightness of customer-side display. Input range: 0 to 100
BRIGHTNESS ADJUSTMENT: OPERATOR SIDE	Adjust the brightness of operator-side display. Input range: 0 to 100
VERT. / HORI.	Switch between the vertical and horizontal screen display.

5.5 SOUND

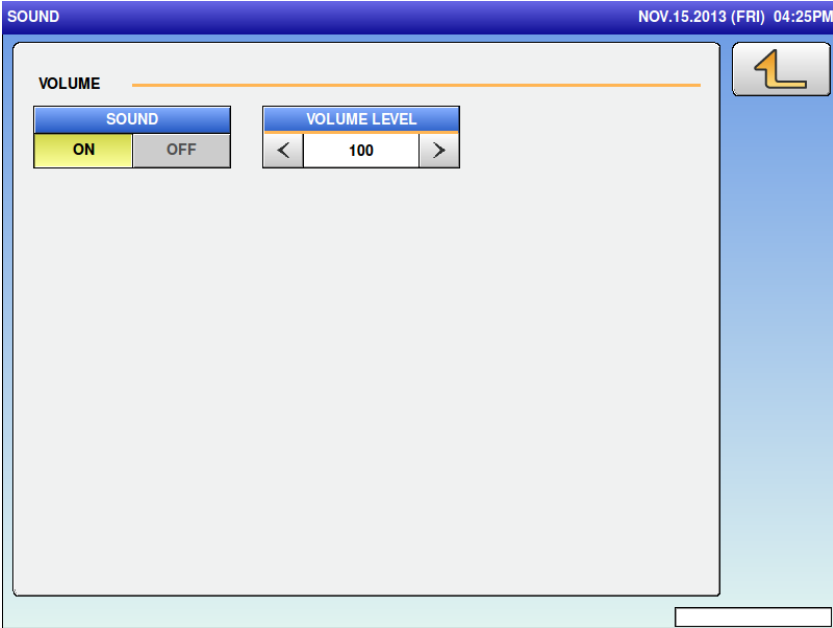

Menu name	Specification
SOUND	Switch between the sound ON and OFF.
VOLUME	Adjust the volume. Input range: 0 to 100

5.6 KEY CHECK

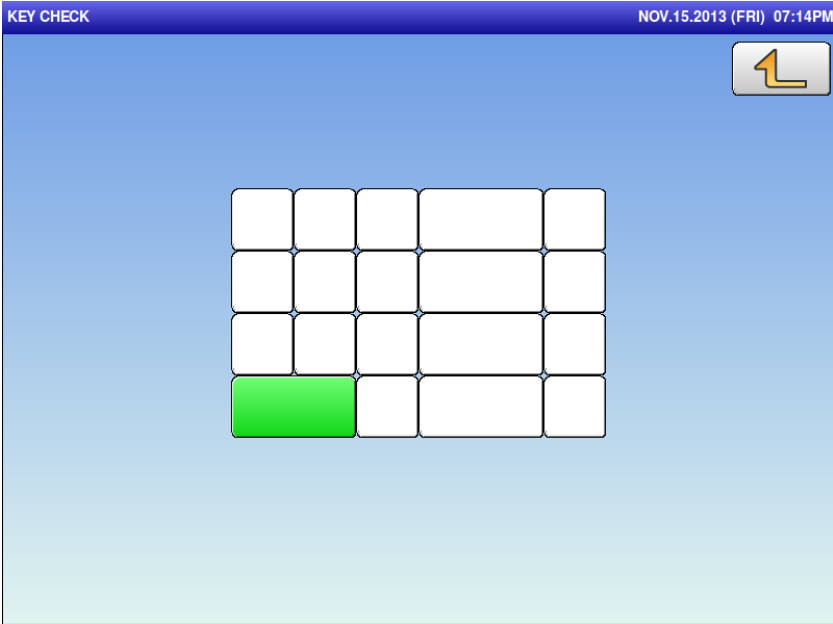

Menu name	Specification
	The touched button changes to green, showing the button is activated.

5.7 FIRMWARE DETAILS

FIRMWARE DETAILS MAY.08.2020 (FRI) 11:23PM

TITLE SOFTWARE: **C2150U** LICENSE 

SOFTWARE	VERSION	SOFTWARE	VERSION
MAIN	C2151T		
SCALE DRIVER (UPDATER)	J0834(J0835)		
OS	J0829E	PRINTER APP.(BOOT)	J0909F(J0827)
BIOS	J0825		
FPGA APP.(BOOT)	J0910B(J0824)		
KEY BOARD	J0823B		
SCALE	J0776G		

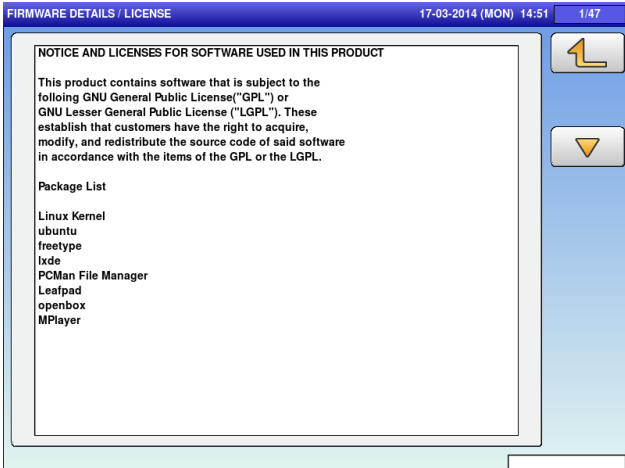
Menu name	Specification
LICENSE	<p>Move to the FIRMWARE DETAILS / LICENSE screen.</p>  <p>The screenshot shows a screen titled 'FIRMWARE DETAILS / LICENSE' with a timestamp of '17-03-2014 (MON) 14:51' and page number '1/47'. The main content area contains the following text:</p> <p>NOTICE AND LICENSES FOR SOFTWARE USED IN THIS PRODUCT</p> <p>This product contains software that is subject to the following GNU General Public License("GPL") or GNU Lesser General Public License ("LGPL"). These establish that customers have the right to acquire, modify, and redistribute the source code of said software in accordance with the items of the GPL or the LGPL.</p> <p>Package List</p> <ul style="list-style-type: none"> Linux Kernel ubuntu freetype ixie PCMan File Manager Leafpad openbox MPlayer

5.8 MEMORY CLEAR

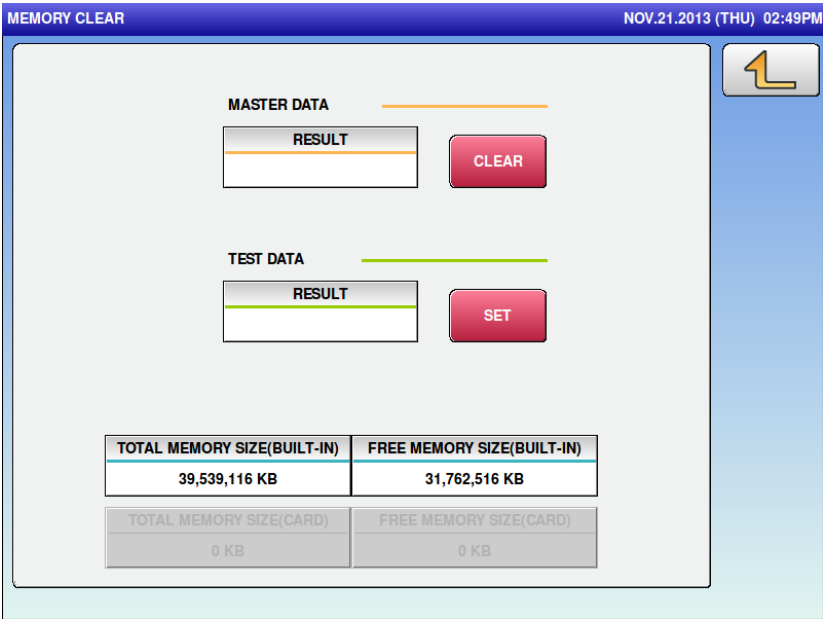

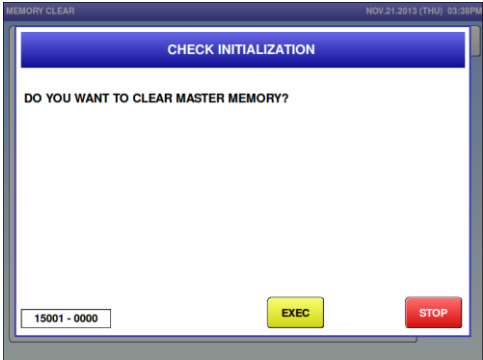
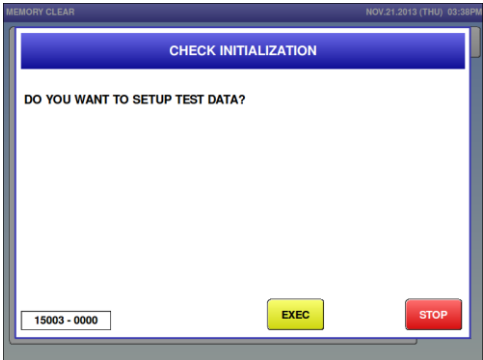
Menu name	Specification
<p>MASTER DATA CLEAR</p>	<p>Clear all DB and initialize the system master.</p> <p>The CHECK INITIALIZATION dialog (memory clear) appears to ask whether to clear the memory.</p> 
<p>TEST DATA SET</p>	<p>Set the initial data and initialize the system master.</p> <p>The CHECK INITIALIZATION dialog (test data setting) appears to ask whether to set the test data.</p> <p>For Oceanian model, the password "951753" should be entered to set the test data.</p> 

Menu name	Specification
MASTER DATA RESULT	Clear the master data and display the result. OK / ERROR
TEST DATA RESULT	Initialize the system data and display the result. OK / ERROR
TOTAL MEMORY SIZE (BUILT-IN)	Display the built-in memory size in kilobyte (kB).
FREE MEMORY SIZE (BUILT-IN)	Display the free memory size in kilobyte (kB).
TOTAL MEMORY SIZE (CARD)	Display the memory size in kilobyte (kB) when the SD card is inserted. If the SD card is not inserted, the option is grayed out.
FREE MEMORY SIZE (CARD)	Display the free memory size in kilobyte (kB) when the SD card is inserted. If the SD card is not inserted, the option is grayed out.

5.9 PRINTER

How to set the hardware for printing and label feeding is described here.

For delivery, perform the adjustment by using the labels actually in use.

To troubleshoot the failures caused by labels, use the genuine monitor labels for comparative evaluation.

5.9.1 PRINTER (HEAD)

Menu name	Specification
PRINTER	Select the printer. Only connected printer is displayed. 1: Model No.1/2: Model No.2/3: External /4: Under/5: POP
FORMAT	Set the format No. for the test print. Input range: 0 to 999 If there is no format, nothing is printed.
TEST PRINT	Select CHECKER (checkered pattern) or NORMAL (normal pattern).
TEST FORMAT(H)	Set the height of format directly. Input range: 0 to 999
HEAD TYPE	Select the head type.
BACK FEED ADJUSTMENT	Adjust the back feed for each label length. Input range: 0 to 99
HEAD USAGE	Set the head travel distance. Input range: 0 to 999

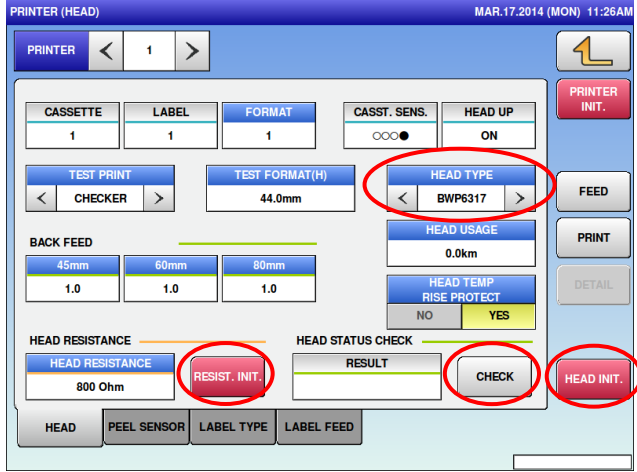
<p>HEAD TEMP RISE PROTECT</p>	<p>Select whether or not to protect the head in case its temperature rises.</p>
<p>HEAD RESISTANCE</p>	<p>Set the head resistance. Input range: 0 to 9999</p>
<p>RESIST.INIT.</p>	<p>Initialize the head resistance.</p>
<p>PRINTER INIT.</p>	<p>Initialize the printer. The CHECK INITIALIZATION dialog (printer initialization) appears to ask whether to initialize the printer. Other tabs also have the same function.</p>
<p>PRINT</p>	<p>Execute the print. Other tabs also have the same function.</p>
<p>FEED</p>	<p>Execute the feed. Other tabs also have the same function.</p>
<p>HEAD INIT.</p>	<p>Initialize the thermal head. The CHECK INITIALIZATION dialog (head initialization) appears to ask whether to initialize the thermal head. Follow the procedure below. ① Press [HEAD INIT.]. ② On the confirmation screen, press [EXEC]. ③ Check HEAD TYPE on the printer to set the the head type to be mounted. ④ Press [RESIST.INIT.] in HEAD RESISTANCE. ⑤ Press [CHECK] in HEAD STATUS CHECK to check the head availability.</p>  <p>The screenshot shows the 'PRINTER (HEAD)' menu with the following elements: <ul style="list-style-type: none"> Buttons: PRINTER, CASSETTE (1), LABEL (1), FORMAT (1), CASST. SENS. (000●), HEAD UP (ON), TEST PRINT (CHECKER), TEST FORMAT (H) (44.0mm), HEAD TYPE (BWP6317), HEAD USAGE (0.0km), BACK FEED (45mm: 1.0, 60mm: 1.0, 80mm: 1.0), HEAD RESISTANCE (800 Ohm), HEAD STATUS CHECK (RESULT), HEAD TEMP RISE PROTECT (NO/YES), HEAD INIT., FEED, PRINT, and DETAIL. Red circles highlight: the 'HEAD TYPE' field, the 'RESIST. INIT.' button, the 'CHECK' button, and the 'HEAD INIT.' button. </p>

5.9.2 PRINTER (PEEL SENSOR)

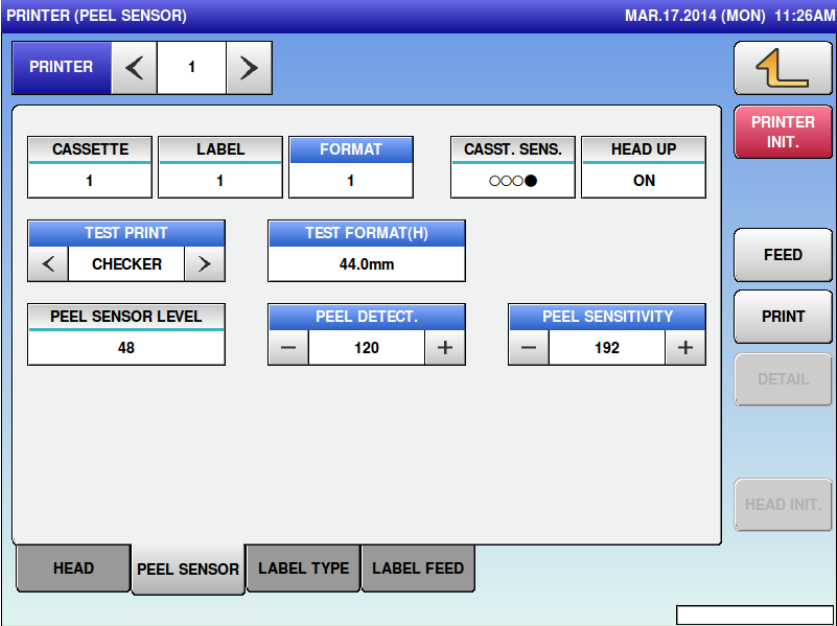

Menu name	Specification
PEEL DETECT.	Set the threshold value of peel sensor. Input range: 0 to 255
PEEL SENSITIVITY	Set the sensitivity of peel sensor. Input range: 0 to 255
PEEL SENSOR LEVEL	Display the output value of peel sensor.
<p>Set the threshold depending on the PEEL SENSOR LEVEL at the time the backing paper remains on the sensor or not.</p> <p>(e.g. If the value at the time the backing paper remains is 180 and if the value at the time the backing paper does not remain is 80, the threshold is set to about 150.)</p>	

5.9.3 PRINTER (LABEL TYPE)

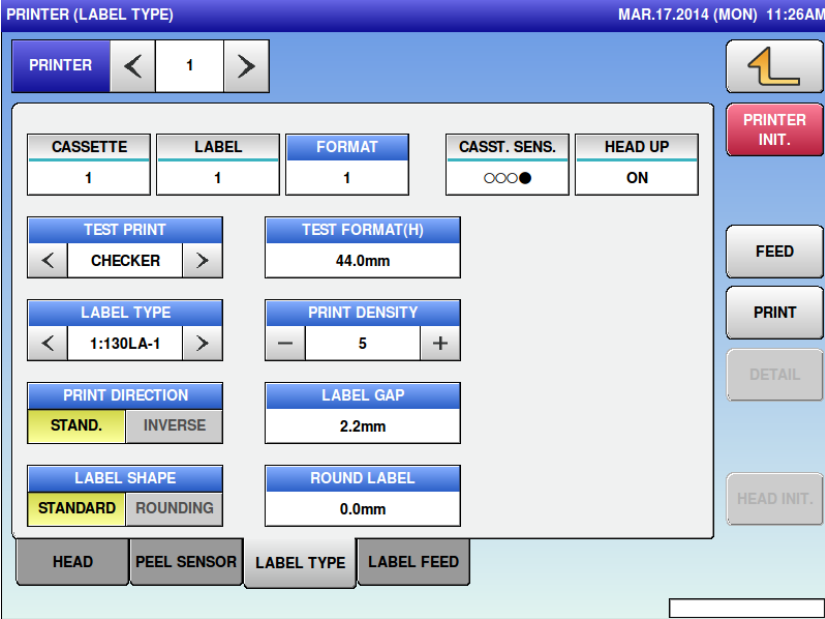

Menu name	Specification
LABEL TYPE	Select the label type. 0:RECEIPT / 1:130LA-1 / 3:150LA-1
PRINT DENSITY	Adjust the print density. Input range: 0 to 9
PRINT DIRECTION	Select the print direction. STAND. / INVERSE
LABEL GAP	Set the "Interval between labels" of the label roll set to the printer. Input range: 0 to 99.9
LABEL SHAPE	Set the label gap (the gap between labels). Input range: 0 to 999
ROUND LABEL	Set the correction value of irregular-shaped label. Input range: 0 to 999

5.9.4 PRINTER (LABEL FEED)

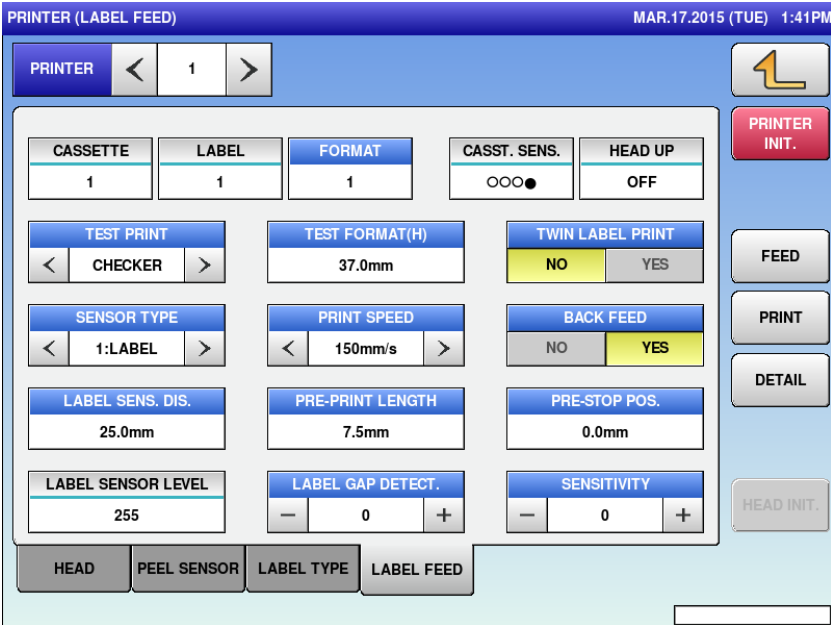

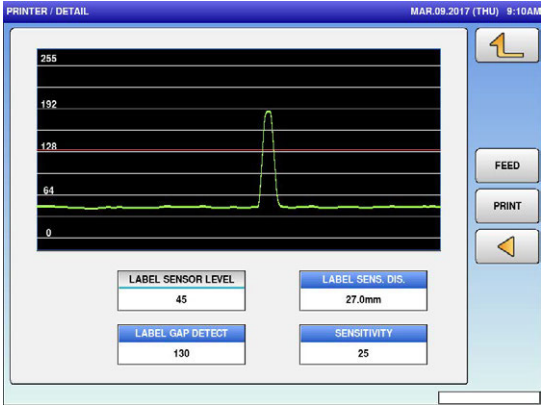
Menu name	Specification
DETAIL	Display the label sensor details screen. 
TWIN LABEL PRINT	Set whether to perform twin label print in the test print. NO: label feed is controlled in pricing in DP mode YES: label feed controlled on pasting label by the labelling machine
SENSOR TYPE	Set the sensor type. 0: NONE / 1: LABEL / 2: MARK
PRINT SPEED	Set the print speed. 100mm/s / 120mm/s / 150mm/s
BACK FEED	Select whether or not to set the back feed.
LABEL SENS. DIS.	Set the label sensor distance. Input range: 0 to 99.9
PRE-PRINT LENGTH	Set the pre-print length. Input range: 0 to 99.9

Menu name	Specification
LABEL GAP DETECT.	Set the label sensor threshold. Input range: 0 to 255
SENSITIVITY	Set the label sensor sensitivity. Input range: 0 to 255
LABEL SENSOR LEVEL	Display the output value of label sensor.
Set the label sensor sensitivity so as not to exceed the peak value of label sensor. (e.g. If the label sensor peak is about 120, the threshold is set to about 100.)	

5.10 CALIBRATION

CALIBRATION APR.13.2015 (MON) 2:30PM

SETTING

CAPACITY	RANGE	SPAN A/D	GRAVITATIONAL ACC.
< 30lb >	SINGLE MULTI	60000	9.7970

SCALE DATA

A/D	CELL VOLTAGE	STATUS
19997		0100 0001

WGT. CONVERTED

WEIGHT A/D	WEIGHT	DATA DISPLAY
0	0.000 lb	WEIGHT VOLTAGE

OTHERS

1083 2004 01003 003000 004001

DIP SW : 00000000

Capacity 0-15lb x 0.005lb 15-30lb x 0.01lb

Menu name	Specification
CAPACITY	Set the capacity of the scale. 6000g / 6kg / 30kg(1/6000) / 30lb / 60lb(1/6000)
RANGE	Select the range. The range to be selected is limited depending on the capacity as following. 6000g / 6kg :MULTI only 30lb :Both SINGLE and MULTI selectable 30kg(1/6000) / 60lb(1/6000) :SINGLE only
GRAVITATIONAL ACC.	Set the gravitational acceleration. Input range: 97799 to 98300
DATA DISPLAY	Select the A/D or cell voltage display.
INITIAL	Initialize the scale.
ZERO	Adjust the current scale status to zero.
SPAN	Set the current scale status to CAPACITY according to the CAPACITY setting.
+	Add span value.
-	Deduct span value.

5.10.1 Procedure for adjusting scale(span)

1. Press INITIAL key to initialize the A/D data.
NOTE: Initialization is not necessary when only minor calibration adjustment is needed.
2. Press the ZERO key to adjust the zero point.
3. Place the full capacity weight on scale and press the SPAN key.
4. Remove the weight and the platter from the scale.
5. Push the Memory switch (SW2 on P-1111*-*) to save the calibration data.
6. Seal off the Memory switch per local regulations.

30 lb Scale Base

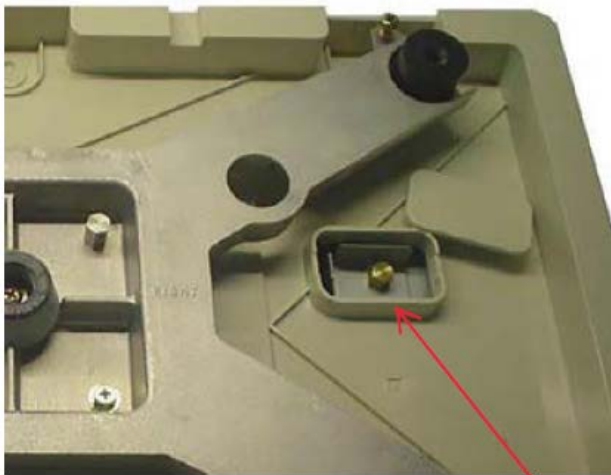

60 lb Scale Base

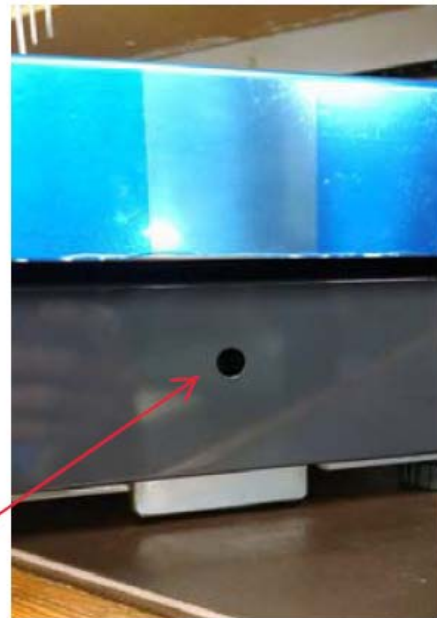

P-1111 SW2: Memory SW Locations

5.11 MACHINE TYPE

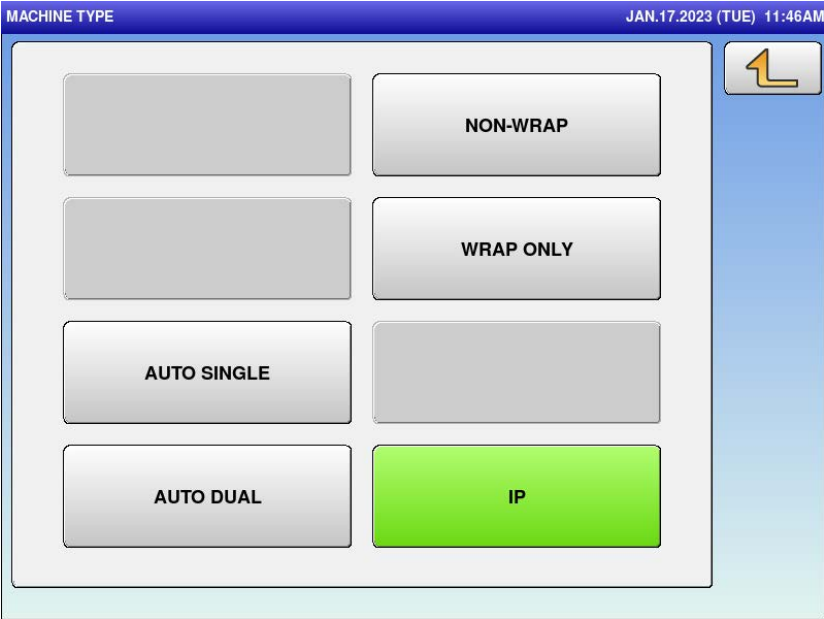

Menu name	Specification
AUTO SINGLE	Judge as the auto pasting single type, move to the [MACHINE TYPE / DETAIL] screen. For AS models, select this option.
AUTO DUAL	Judge as the auto pasting dual type, move to the [MACHINE TYPE / DETAIL] screen. For AT models, select this option.
NON-WRAP	Judge as the inspection unit, move to the [MACHINE TYPE / DETAIL] screen.
WRAP ONLY	Judge as the single wrapper model type, move to the [MACHINE TYPE / DETAIL] screen. For the models without printer, select this option.
IP	Judge as the prepack scale and printer with remote scale base model type, move to the [MACHINE TYPE / DETAIL] screen.

5.11.1 MACHINE TYPE / DETAIL

MACHINE TYPE / DETAIL JAN.17.2023 (TUE) 11:46AM

STRUCTURE IP TYPE IP PRODUCT ID 0000000

WRAPPER

PRINTER

PRINTER 1 CONNECTION OK

OUTSIDE PRINTER NO YES

PRINT DOT RATIO 1 : 1 1 : 1.1

PRINTER 2 CONNECTION PP PRODUCT ID PRINTER 1 POS. SEL. LEFT RIGHT

SET

Menu name	Specification
STRUCTURE	Display the configuration selected by the previous screen [MACHINE TYPE].
IP PRODUCT ID	Set the product ID in seven digits.
PRINTER 1 CONNECTION	Display the communication status with Printer No. 1.
OUTSIDE PRINTER	Select and set whether to connect the external printer.
PRINT DOT RATIO	Select and set the printing dot ratio. Printing is elongated using 1.1.
PRINTER 2 CONNECTION	Display the communication status with Printer No. 2.
PRINTER 1 POS. SEL.	Specify the printer No. 1 for the dual specification.
SET	Save the setting (with confirmation message).

5.12 DOWNLOAD

5.12.1 DOWNLOAD (MAIN)

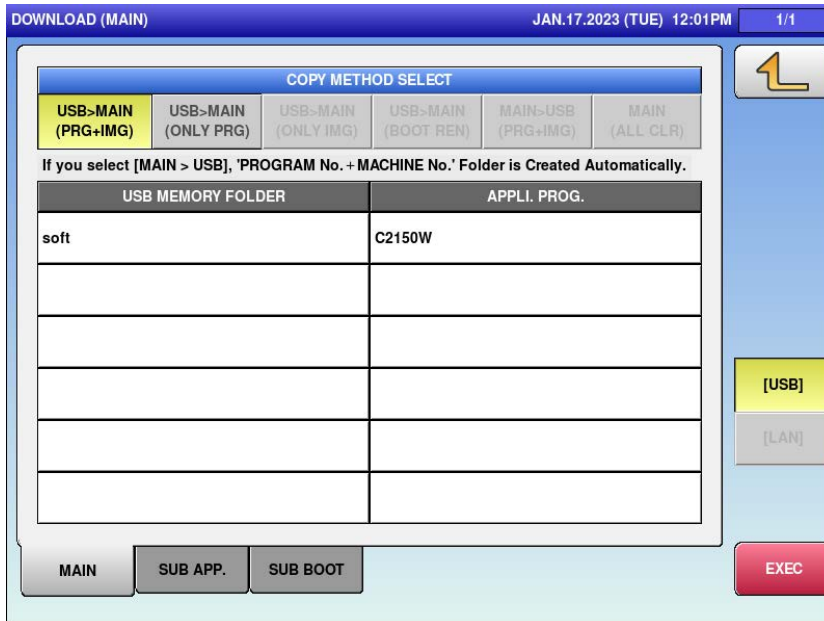

Menu name	Specification
COPY METHOD SELECT	When "USB>MAIN (PRG+IMG)" is selected, the program and the image data of the selected USB memory folder are downloaded. When "USB>MAIN (ONLY PRG)" is selected, only the program of the selected USB memory folder is downloaded. The image data is not downloaded.
USB MEMORY FOLDER	Select the firmware to be downloaded.
APPLI. PROG.	Select the firmware to be downloaded.
EXEC	Download the selected program. The CHECK EXECUTION OF MAIN PROGRAM DOWNLOAD dialog appears to ask whether to download the program.

Note:

• Precautions on software write after board replacement

Until all software completes write operations, the following phenomenon may occur. This occurs because of the incompatibility between software in the flash memory of the board and the main application software in CF (compact flash).

<LED remains ON after shutdown>

The power switch of the applicable models is turned OFF after software write. LED on the P-1100 board, however, may remain ON even upon OS shut down and the screen becomes black. In this case, turn OFF the breaker or pull out the power supply plug, and make sure that LED is turned OFF. After 20 to 30 seconds, turn ON the breaker or insert the power supply plug, and turn ON the power switch.

<Error display>

Errors such as a battery error or communication error may be displayed on the screen before software starts the write operation after starting the main application software. In this case, continue the software write operation. If the error display persists even after all software completes write operations, memory initialization, and basic settings such as model setting, take measures to correct each error.

5.12.2 DOWNLOAD (SUB APP.)

PROGRAM FILE NAME	SEND MACHINE NAME
J0911C.MOT	EC
FPGA_APLY_J0910B.BIN	FPGA

Buttons: MAIN, SUB APP., SUB BOOT, [MAIN], [USB], EXEC

IMPORTANT: Select and download each applicable sub-app program one at a time.

Menu name	Specification
PROGRAM FILE NAME	Select the firmware to be downloaded.
SEND MACHINE NAME	Select the firmware to be downloaded.
MAIN/USB	Select where the program is downloaded from. MAIN / USB
EXEC	Download the selected program. The CHECK FOR EXECUTION OF DEVICE MACHINE PROGRAM dialog appears to ask whether to download the program.

Note:

• Precautions on software write after board replacement

Until all software completes write operations, the following phenomenon may occur. This occurs because of the incompatibility between software in the flash memory of the board and the main application software in CF (compact flash).

<LED remains ON after shutdown>

The power switch of the applicable models is turned OFF after software write. LED on the P-1100 board, however, may remain ON even upon OS shut down and the screen becomes black. In this case, turn OFF the breaker or pull out the power supply plug, and make sure that LED is turned OFF. After 20 to 30 seconds, turn ON the breaker or insert the power supply plug, and turn ON the power switch.

<Error display>

Errors such as a battery error or communication error may be displayed on the screen before software starts the write operation after starting the main application software. In this case, continue the software write operation. If the error display persists even after all software completes write operations, memory initialization, and basic settings such as model setting, take measures to correct each error.

5.12.3 DOWNLOAD (SUB BOOT)



Menu name	Specification
PROGRAM FILE NAME	Touch this button to switch the selections.
SEND MACHINE NAME	Touch this button to switch the selections.
MAIN/USB	Select where the program is downloaded from. MAIN / USB
EXEC	Download the selected program. The CHECK FOR EXECUTION OF DEVICE MACHINE PROGRAM dialog appears to ask whether to download the program.

5.13 OPTION CHECK

5.13.1 OPTION CHECK (SCANNER)

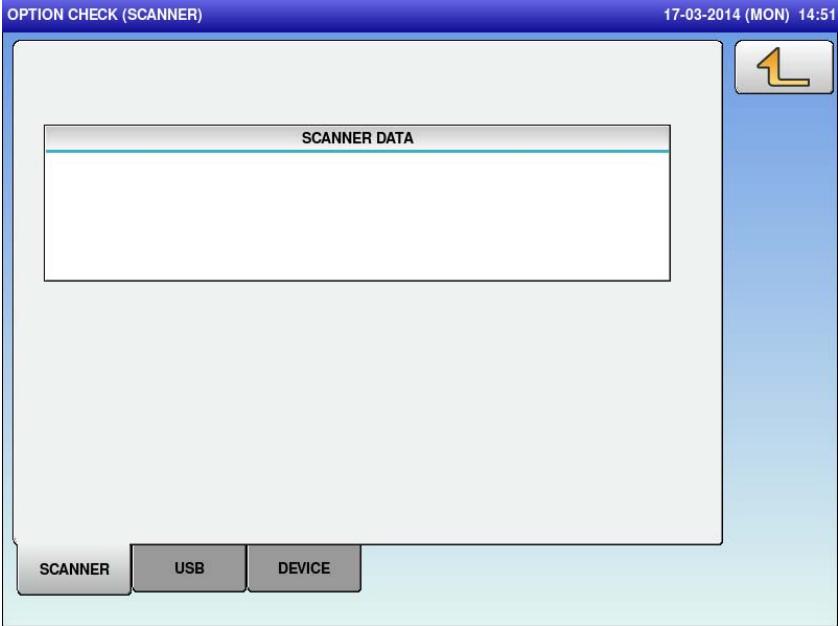

Menu name	Specification
SCANNER DATA	Display the scanned data.

5.13.2 OPTION CHECK(USB)

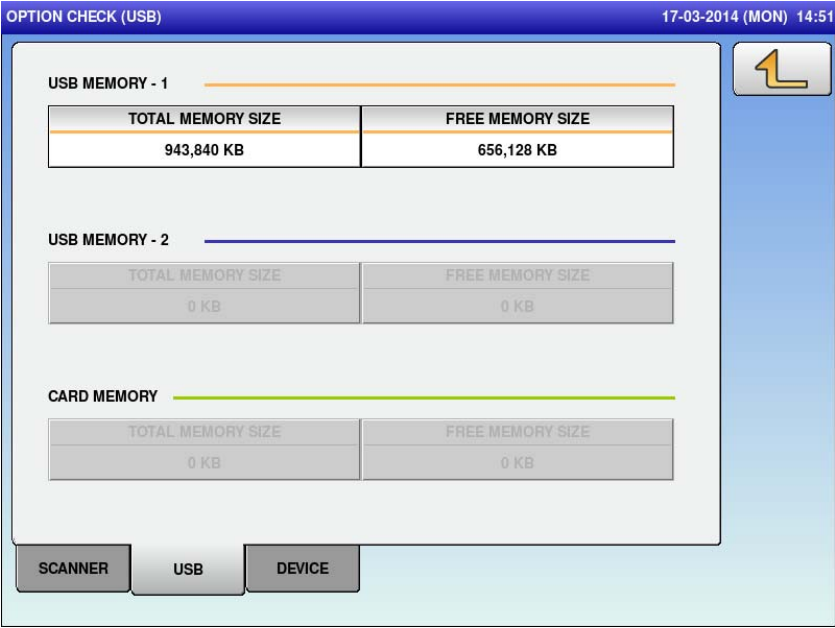

Menu name	Specification
USB MEMORY -1	Display the information of connected USB memory.
USB MEMORY -2	Display the information of connected USB memory.
CARD MEMORY	Display the information of connected SD card memory.

5.13.3 OPTION CHECK (DEVICE)

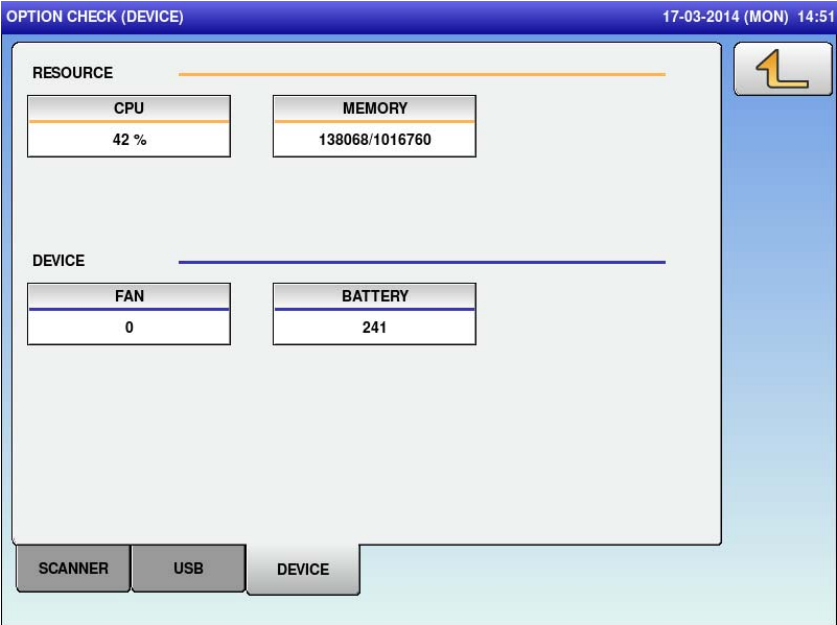

Menu name	Specification
CPU	Display the CPU use rate.
MEMORY	Display the use size and the total size of the internal memory.
FAN	Display the rotation count of the CPU fan. Unit: internal count
BATTERY	Display the battery voltage. Unit: internal AD value

5.14 DISPLAY CAPTURE



Menu name	Specification
DISPLAY CAPTURE	<p>Select display capturing.</p> <p>At power ON, [NO] is selected as a default setting.</p> <p>Selecting [YES] displays the camera mark at the lower left side of the screen. Pressing the camera mark on each screen captures the screen, and creates the PNG file. The data is stored in the Capture folder in the USB memory.</p> <p>The PNG file name is created in series with the name from "000_xxxx.jpg" to "999_xxxx.jpg" (xxxx refers to the screen name). When a file already has the same name, the file is overwritten. The data is reset when the power is ON, and is created again from the name "000_xxxx.jpg".</p>

5.15 GRAVITY

GRAVITY NOV.21.2013 (THU) 01:55PM

SETTING

CAPACITY	RANGE	SPAN A/D	GRAVITATIONAL ACC.
15kg	MULTI	75000	9.8066

SCALE DATA

A/D	STATUS
20000	0101 0001

WGT. CONVERTED

WEIGHT A/D	WEIGHT
0	0.000 kg

OTHERS

DIP SW : 00000000

ZERO

Capacity 0- 6kg x 0.002kg 6-15kg x 0.005kg

Menu name	Specification
CAPACITY	Display the capacity.
RANGE	Display the range type.
GRAVITATIONAL ACC.	Set the gravitational acceleration. Setting range: 97799 to 98300
SPAN A/D	Display the span count.
A/D	Display the A/D count.
STSTATUS	Display the scale status.
WEIGHT A/D	Display the A/D count for weight conversion.
WEIGHT	Display the weight.
DIP SW	Display the DIP SW status of the scale.
ZERO	Display the zero point adjustment.

6.1 Error Message

■ Error screen

When the machine detects an error, the following error message and error No. are displayed. Some errors can be recovered simply by pressing corresponding buttons.

Some require combination of the button and simple operations, or maintenances such as replacing parts.

Be sure to check an error No. when you receive an inquiry from a user.

Even error messages are similar, different solution may be necessary to clear the errors.

Error No. consists of main No. (4 digits) + Sub-No. (4 digits).

If only a type of sub-No. (0000) exists, an error message list displays main No. only.

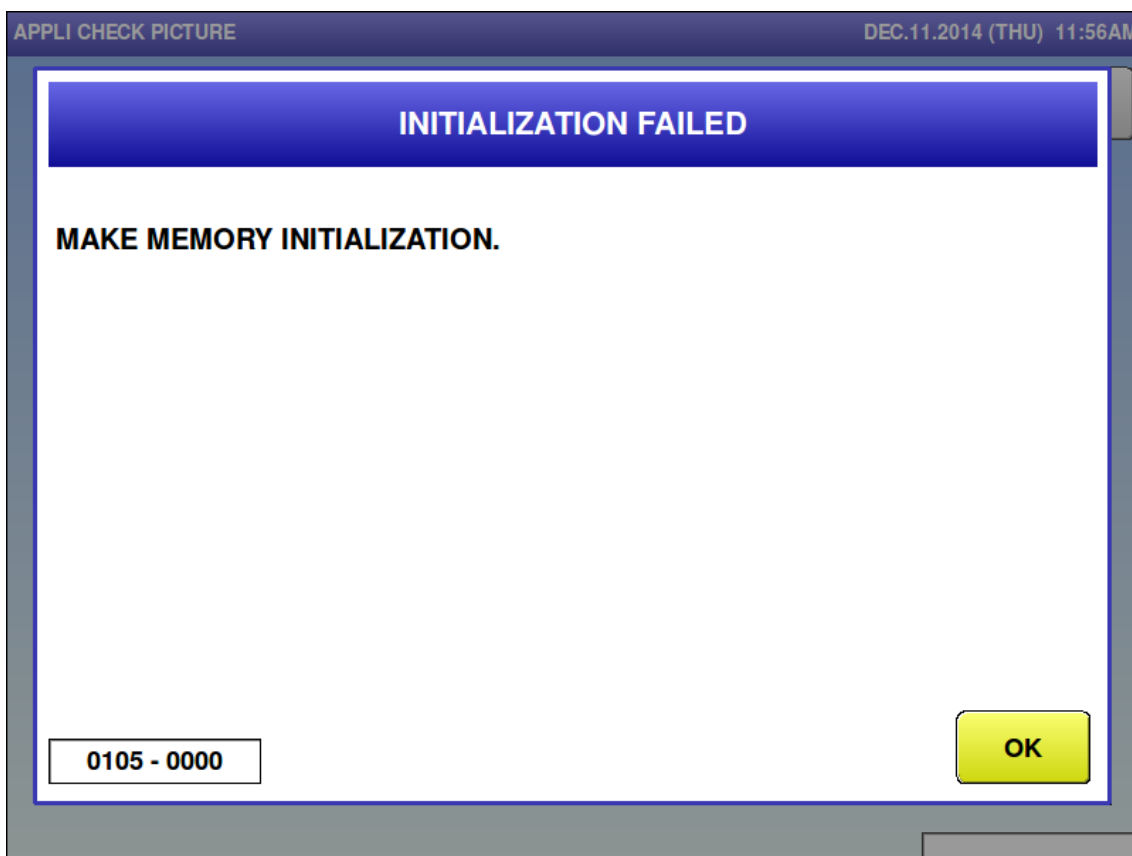

Screen 2: Example of error screen

6.2 Error Codes

6.2.1 System-related Error (No. 100s)

- Initialization failed (0105)

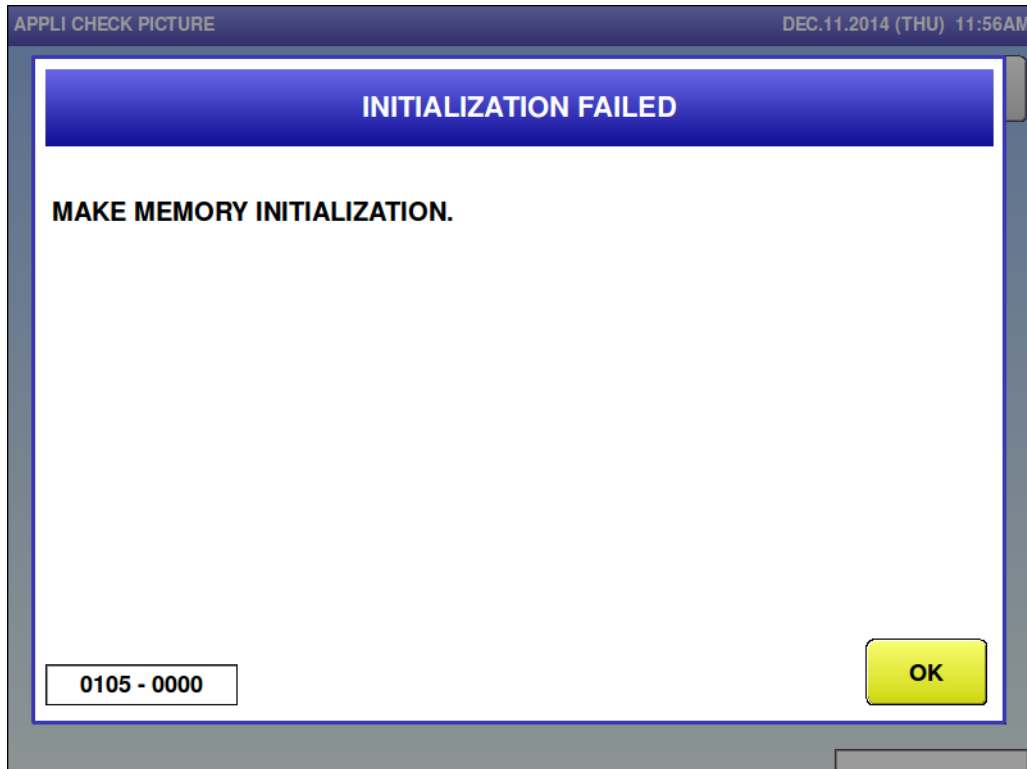

Error content	Initialization failed.
Detail	Initialization has not been performed.
Solution	[OK] button
Action by user	
Action by service representative	Perform memory initialization.
Related part	Main board
Remarks	Memory needs to be cleared on the [ADJUST (MEMORY CLEAR)] screen.

- Battery is faulty (0106)

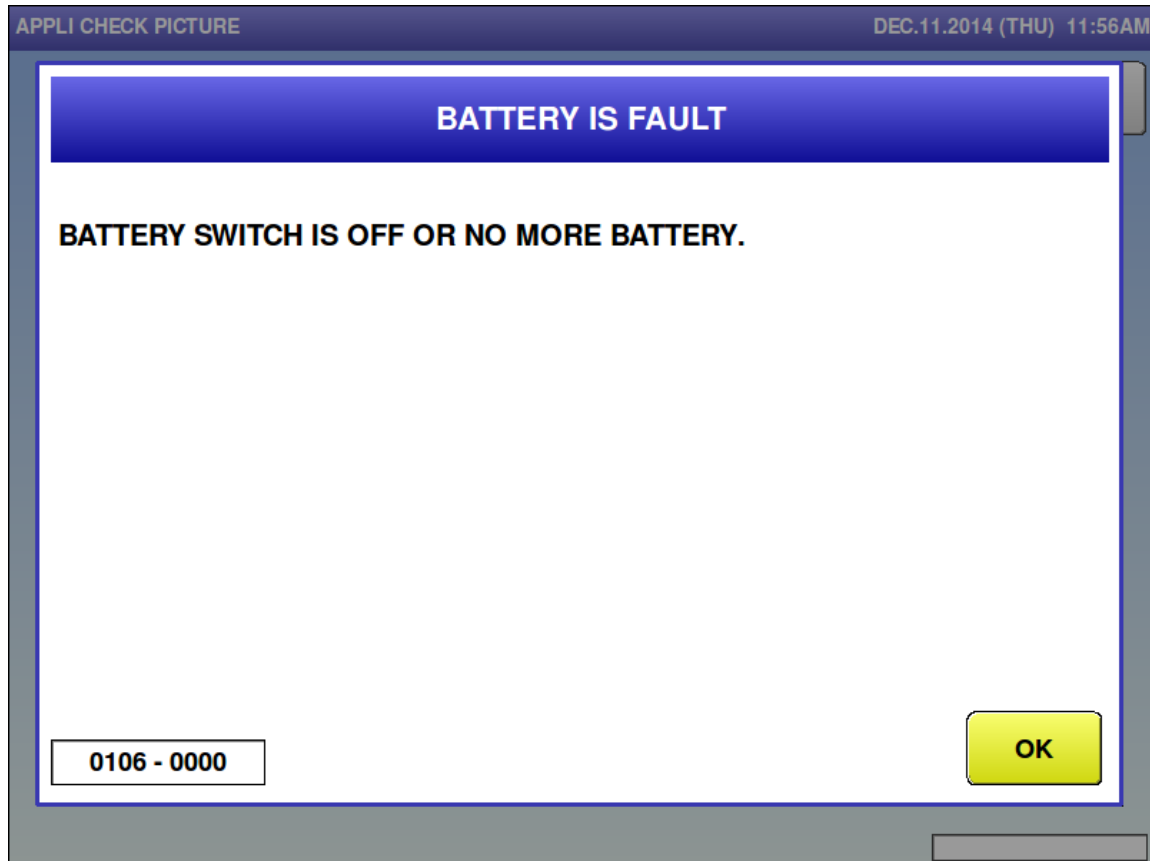

Error content	Battery is faulty.
Detail	Battery in the board is exhausted.
Solution	[OK] button
Action by user	
Action by service representative	Check the battery of the main board. Check the battery switch of the main board.
Related part	Main board
Remarks	Turn off the machine and replace the battery in the board. Confirm the battery switch.

- Touch screen adjustment is not completed yet (0107)

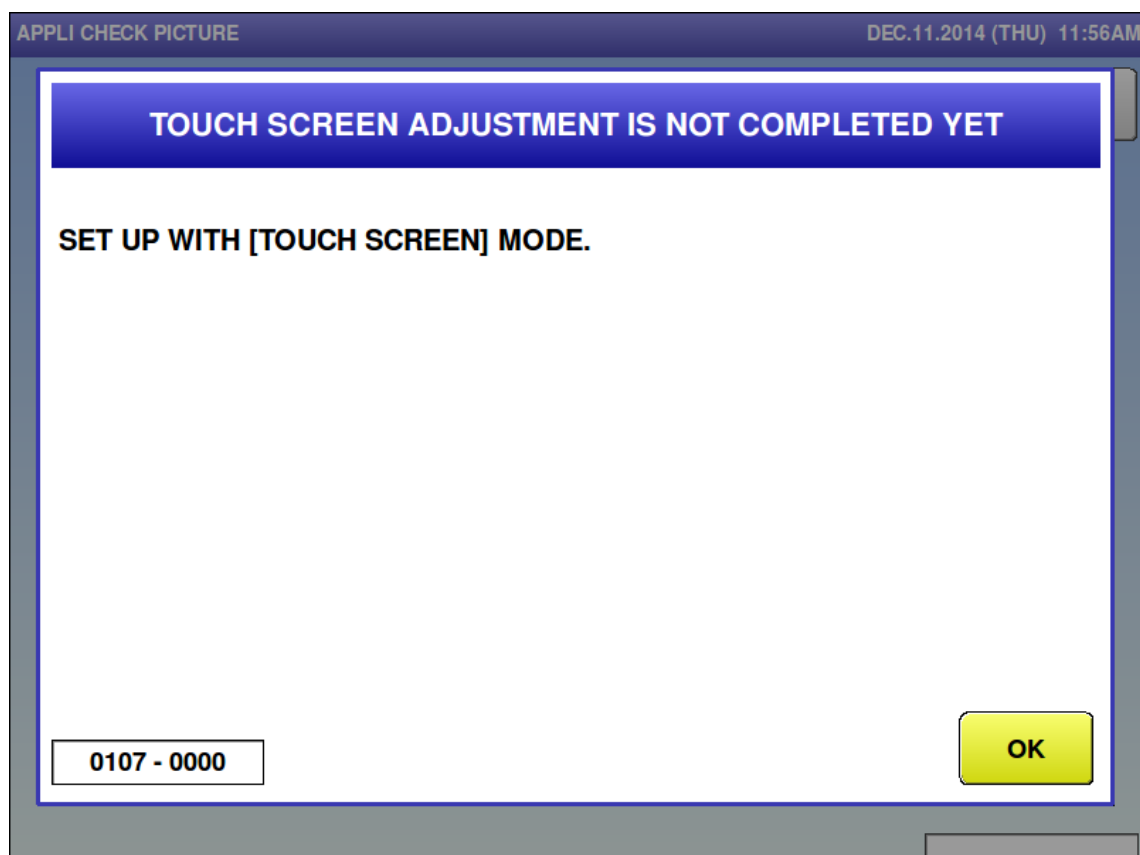

Error content	Touch screen adjustment is not completed yet.
Detail	
Solution	[OK] button
Action by user	Perform touch panel adjustment.
Action by service representative	Perform touch panel adjustment.
Related part	Main board Display board
Remarks	Set up on the [ADJUST (TOUCH SCREEN)] screen.

■ Clock setting is not completed yet (0108)

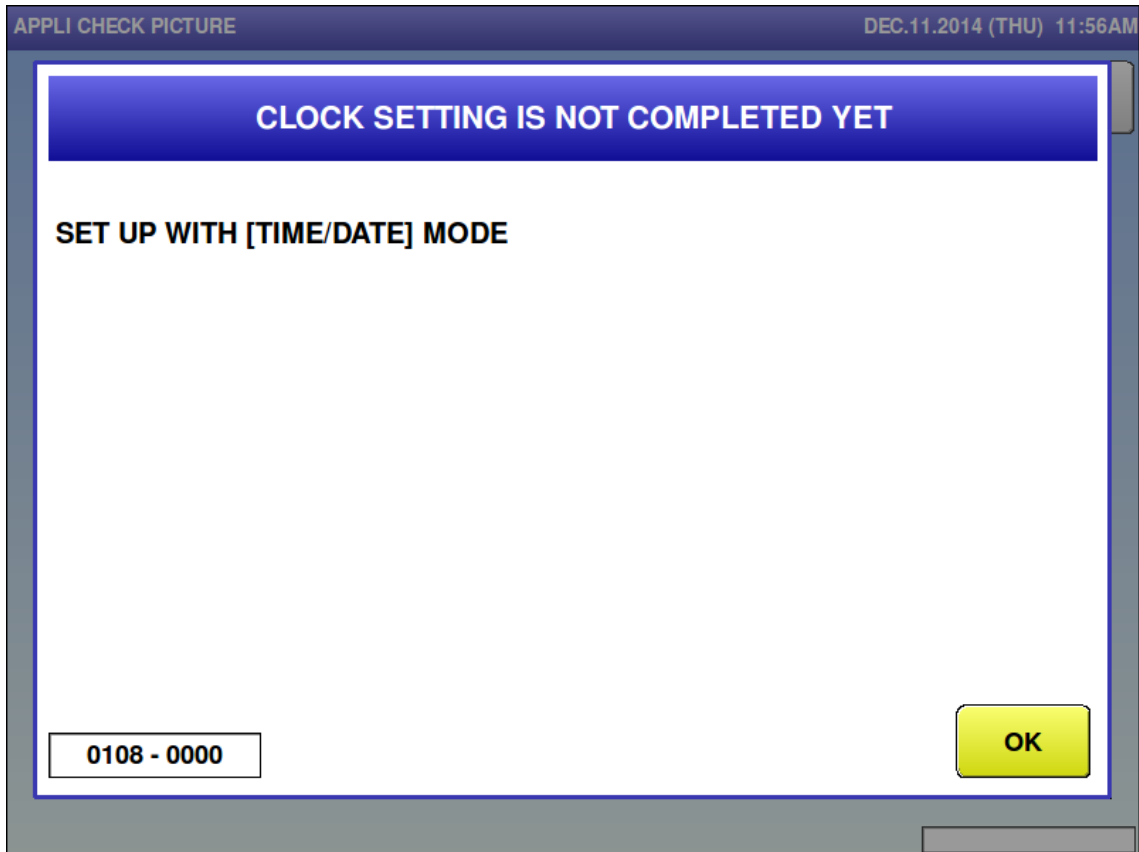

Error content	Clock setting is not completed yet.
Detail	
Solution	[OK] button
Action by user	Perform date adjustment.
Action by service representative	Perform date adjustment.
Related part	Main board
Remarks	Set up on the [ADJUST (DATE TIME)] screen.

- Printer 1 initialization was not done yet (0109)

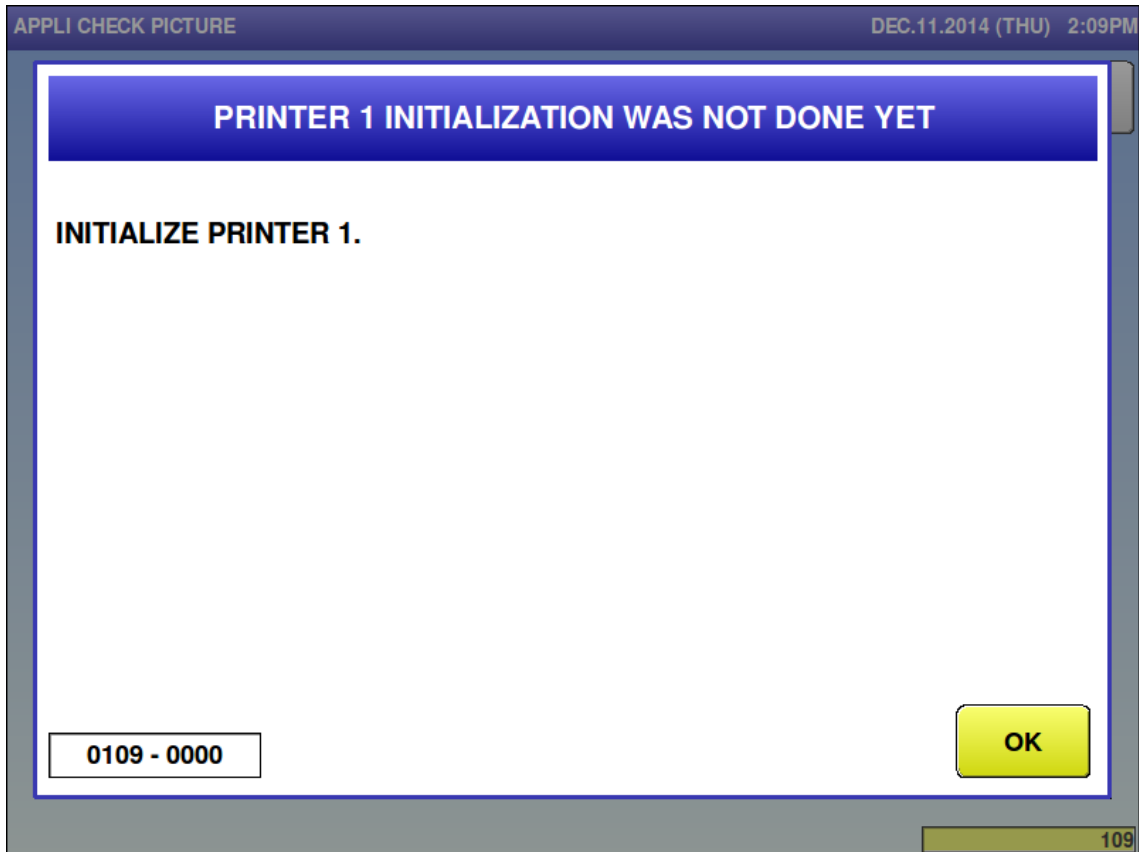

Error content	Printer 1 initialization was not done yet.
Detail	Sub-error is the printer number. 0000: Printer No.1 0001: Printer No.2
Solution	[OK] button
Action by user	
Action by service representative	Perform printer initialization.
Related part	Main board
Remarks	The title of "Printer No.1" depends on sub error No. Perform printer initialization on the [ADJUST (PRINTER)] screen.

■ Machine setting is not completed (0110)

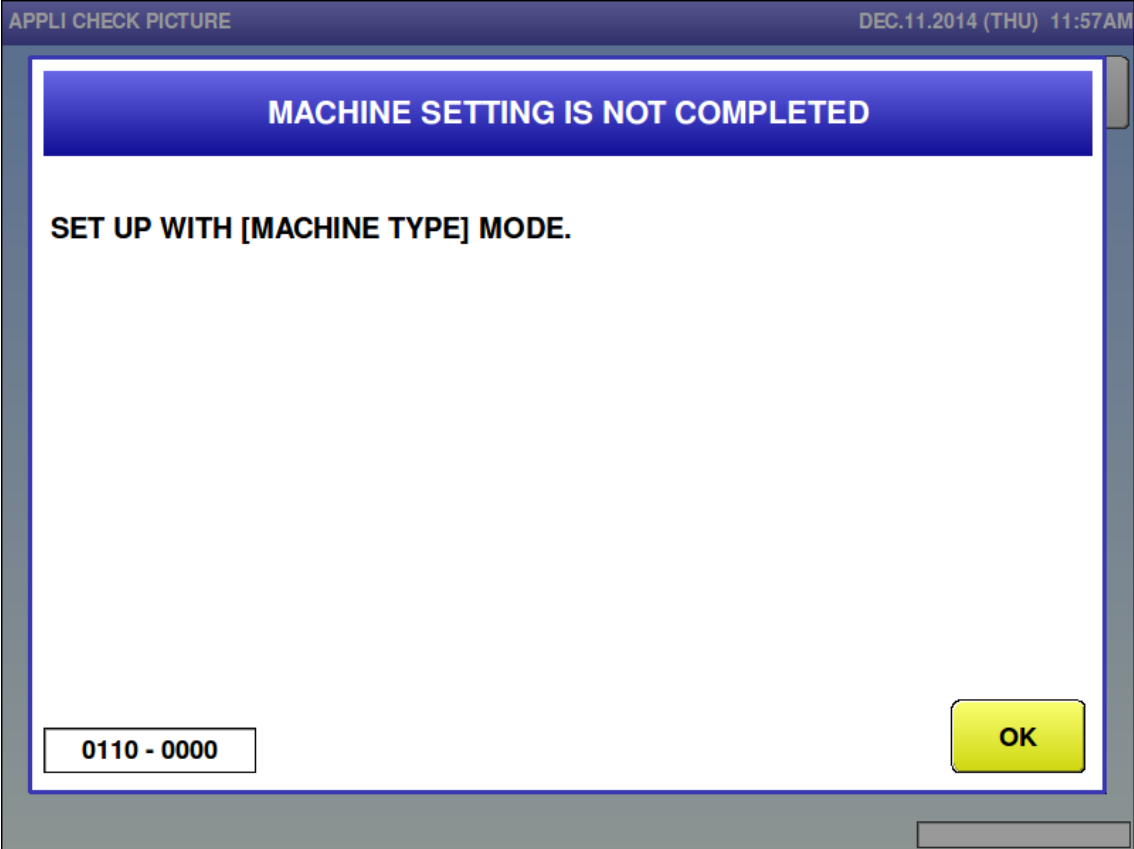

Error content	Machine setting is not completed.
Detail	
Solution	[OK] button
Action by user	
Action by service representative	Perform machine type settings.
Related part	Main board
Remarks	Set up on the [ADJUST (MACHINE TYPE)] screen.

- The display confirmation is not completed (0111)

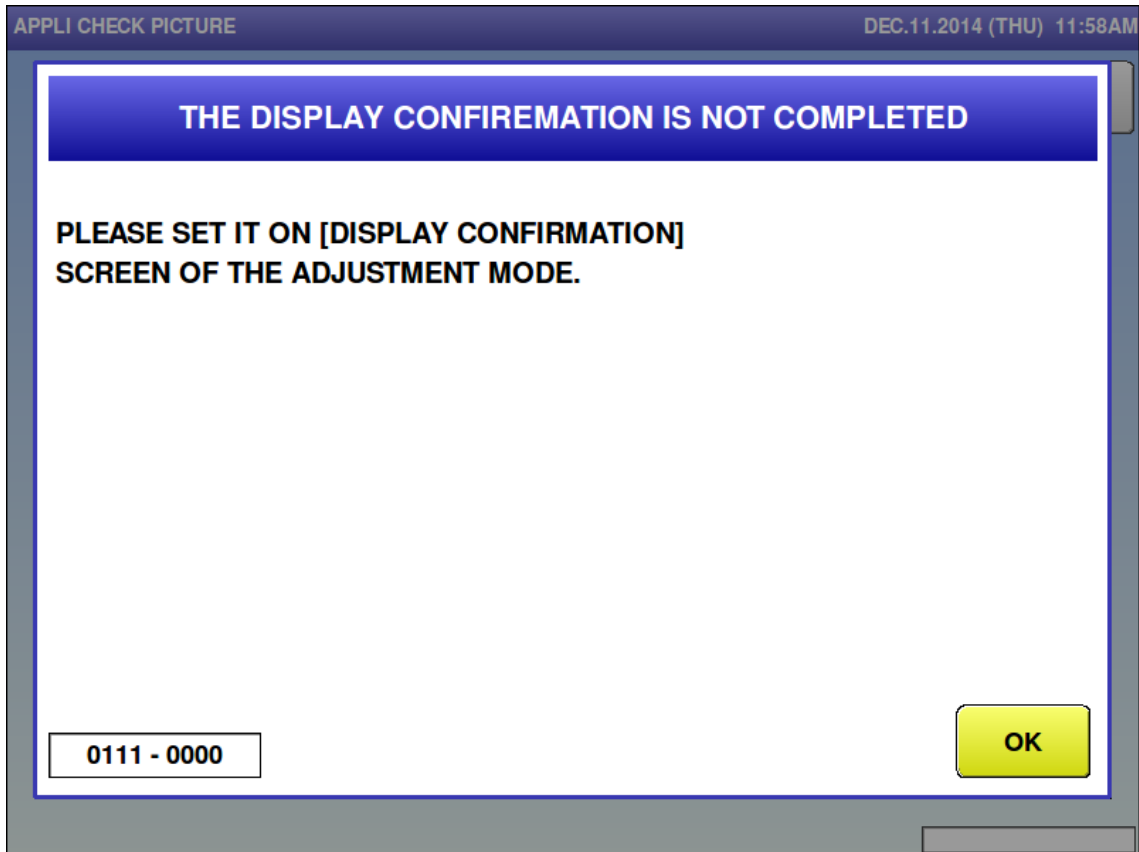

Error content	The display confirmation is not completed.
Detail	
Solution	[OK] button
Action by user	
Action by service representative	Perform display settings.
Related part	Main board
Remarks	Set the brightness on the [ADJUST(DISPLAY CHECK)] screen.

■ Confirm operation of the tactile keyboard (0112)

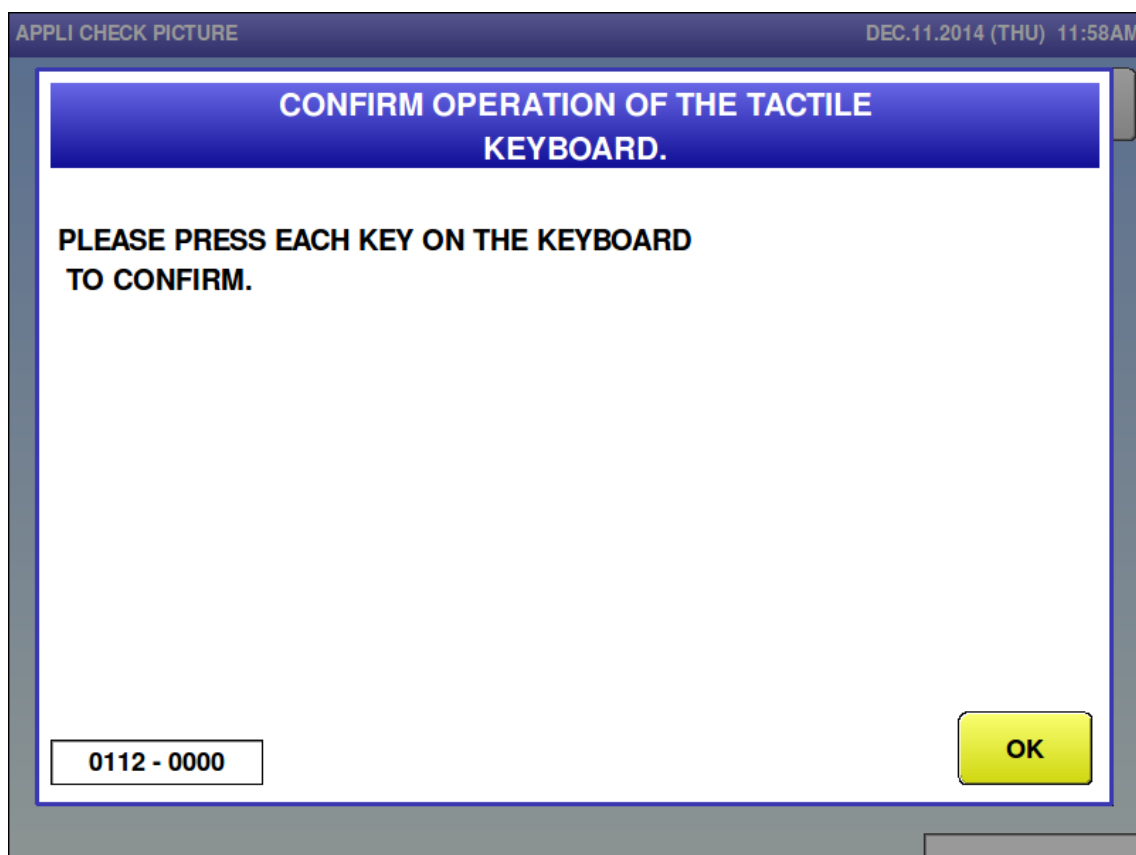

Error content	Confirm operation of the tactile keyboard
Detail	
Solution	[OK] button
Action by user	
Action by service representative	Confirm the key operation.
Related part	Main board Display key board
Remarks	Check the key on the [ADJUST (KEY CHECK)] screen.

■ Data composition is different (0114)

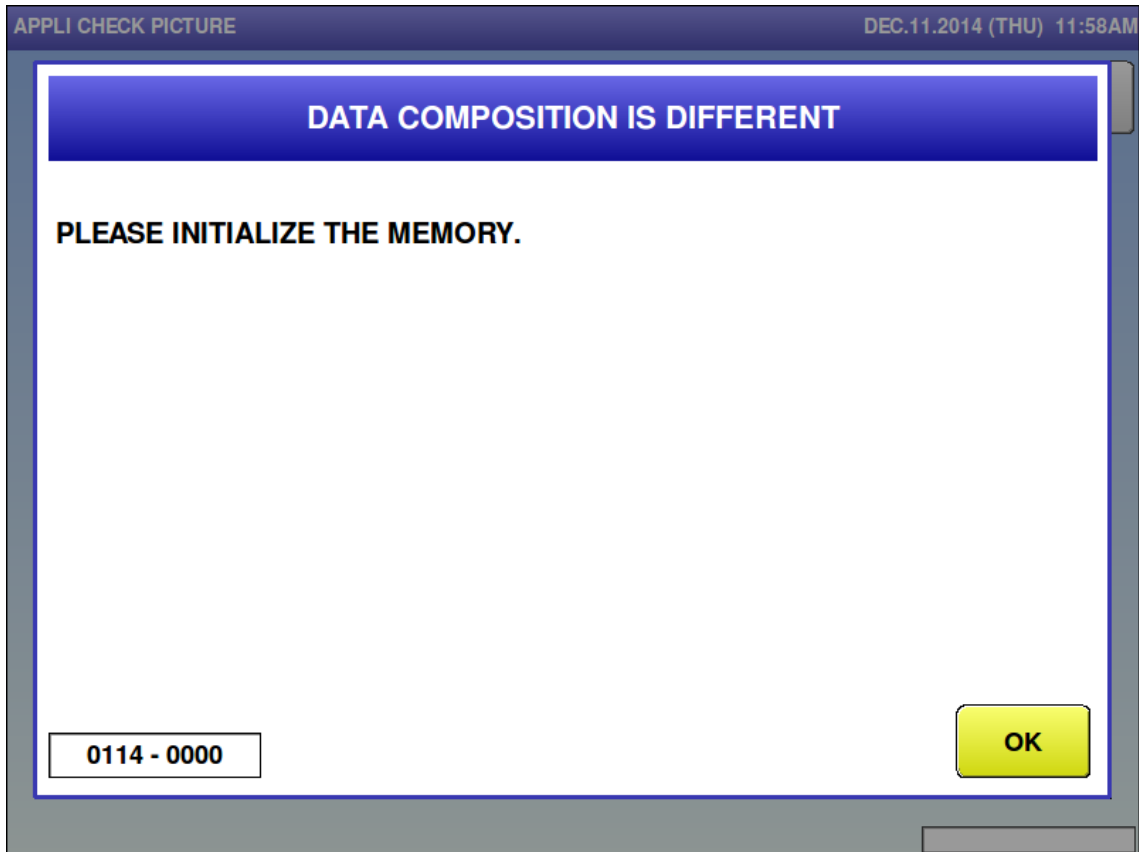

Error content	Data composition is different.
Detail	Data composition of data base is different
Solution	[OK] button
Action by user	
Action by service representative	Master return after memory initialization
Related part	Main board
Remarks	Data composition is different Change is made to data composition.

- The country has not been selected (0118-0000)



Error content	Confirm country selection.
Detail	Country is not selected.
Solution	[OK] button
Action by user	
Action by service representative	Select a country.
Related part	Main board
Remarks	

■ FAN is abnormal. (0121-0000)

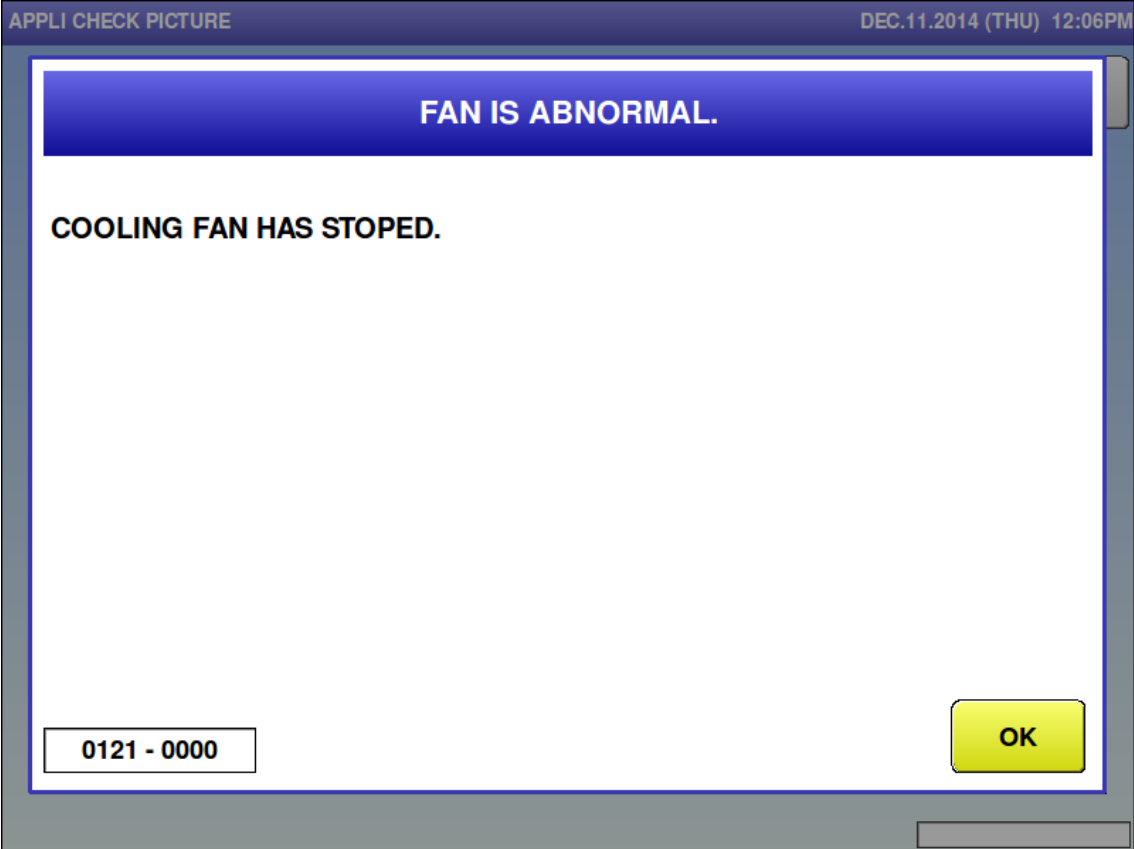

Error content	FAN error
Detail	
Solution	[OK] button
Action by user	
Action by service representative	Check the connection between the main board and fan. Check the fan.
Related part	Main board CPU-FAN
Remarks	

6.2.2 Memory-related Error (No. 200s)

- PLU master is not programmed (0202)

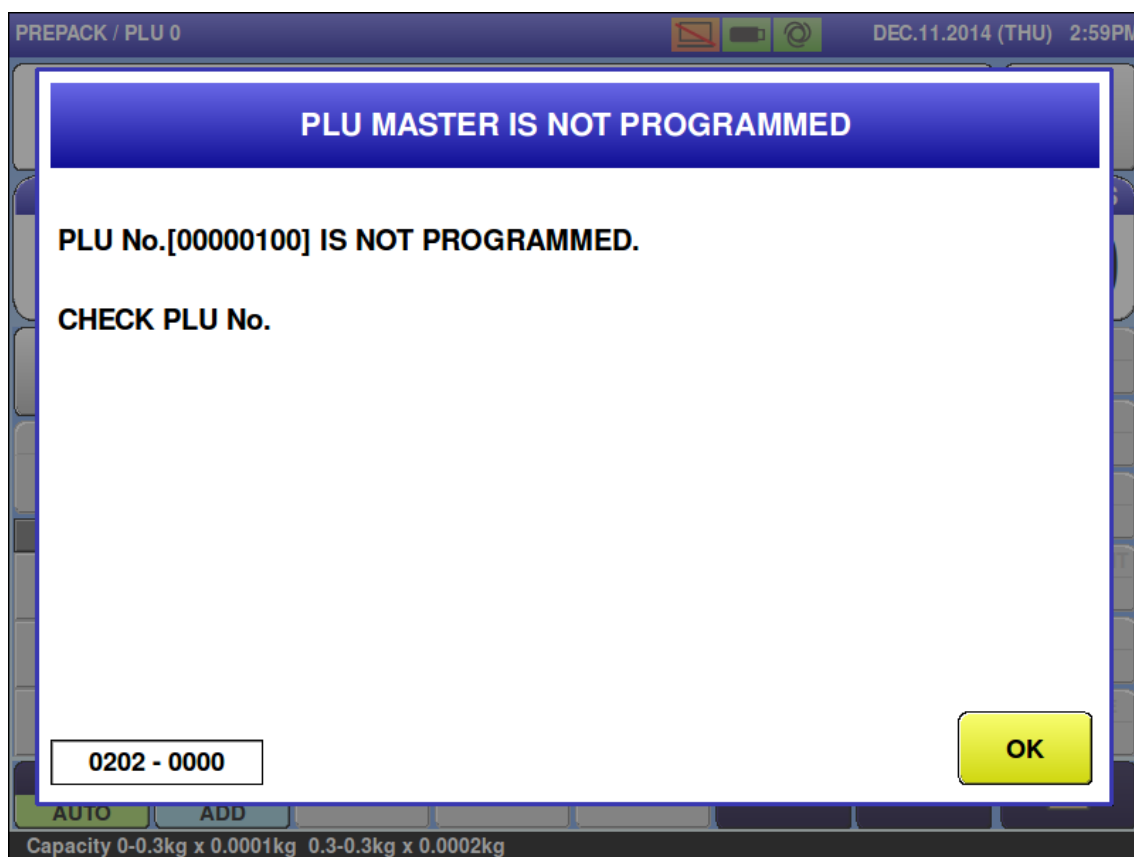

Error content	PLU master is not programmed
Detail	The PLU does not exist in the machine's memory.
Solution	[OK] button
Action by user	Reconfirm the PLU No. Program the PLU.
Action by service representative	Recheck the PLU No. Setting mode (Production): Confirm the auto product deletion setting.
Related part	
Remarks	The product number is displayed.

■ POP master is not programmed (0203)

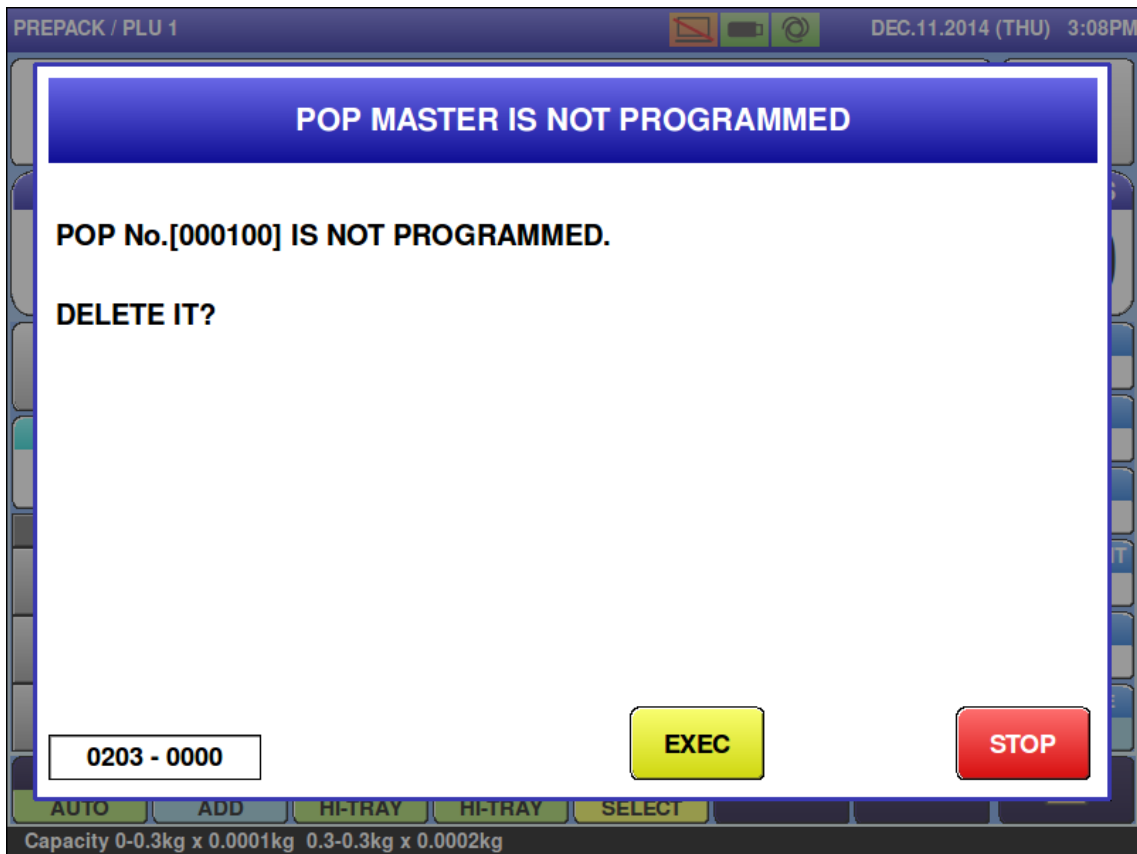

Error content	The called Pop Message is not found.
Detail	The message doesn't exist in the machine's memory.
Solution	[EXEC] button => Delete the PLU's link with the Pop Message. [STOP] button => Cancel error.
Action by user	Recheck the Pop Message number. Program the Pop Message.
Action by service representative	Recheck the Pop Message number. Program the Pop Message.
Related part	
Remarks	The error for a missing message linked to a PLU can be disabled in the Setup menu > Error Process > Call tab.

■ Tray master is not programmed (0210)

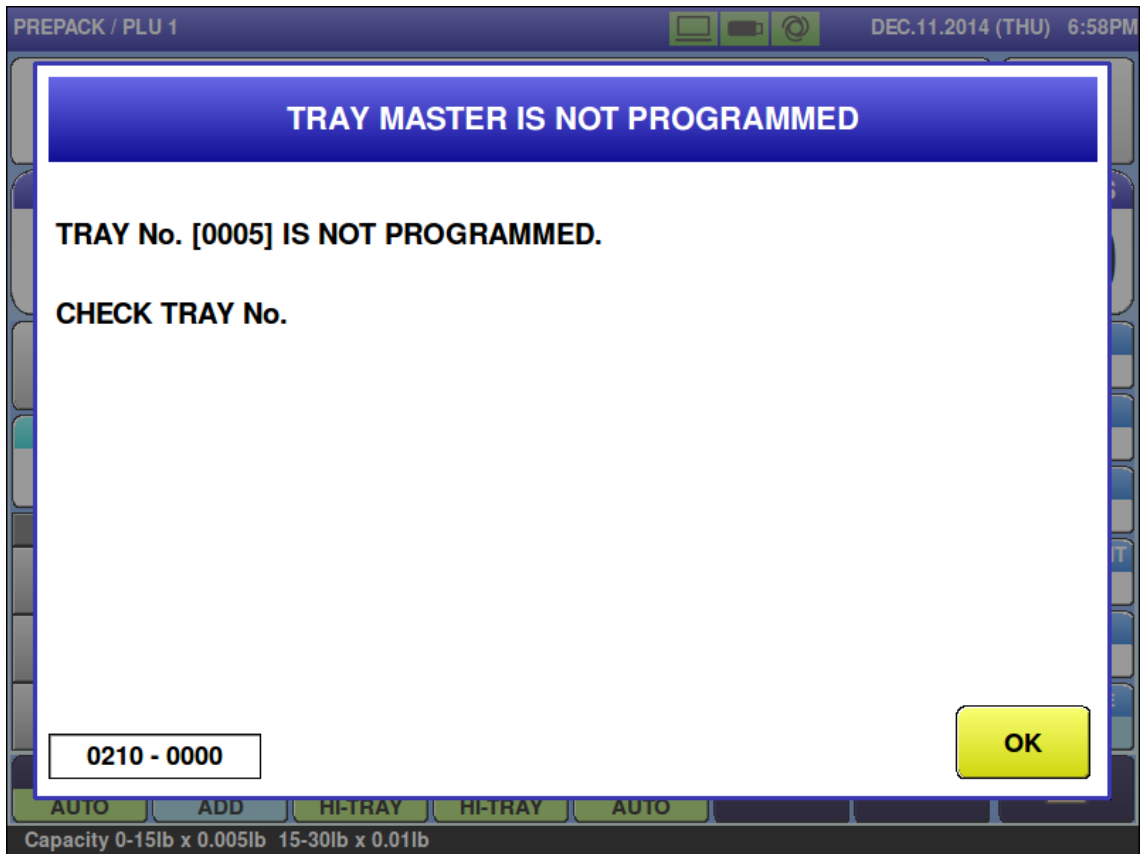

Error content	Tray master is not programmed.
Detail	The tray does not exist in the machine's memory.
Solution	[OK] button
Action by user	Recheck the Tray No. Program the Tray.
Action by service representative	Confirm the master.
Related part	Main board
Remarks	Tray master No. is registered.

■ Free 1 master is not registered (0212)

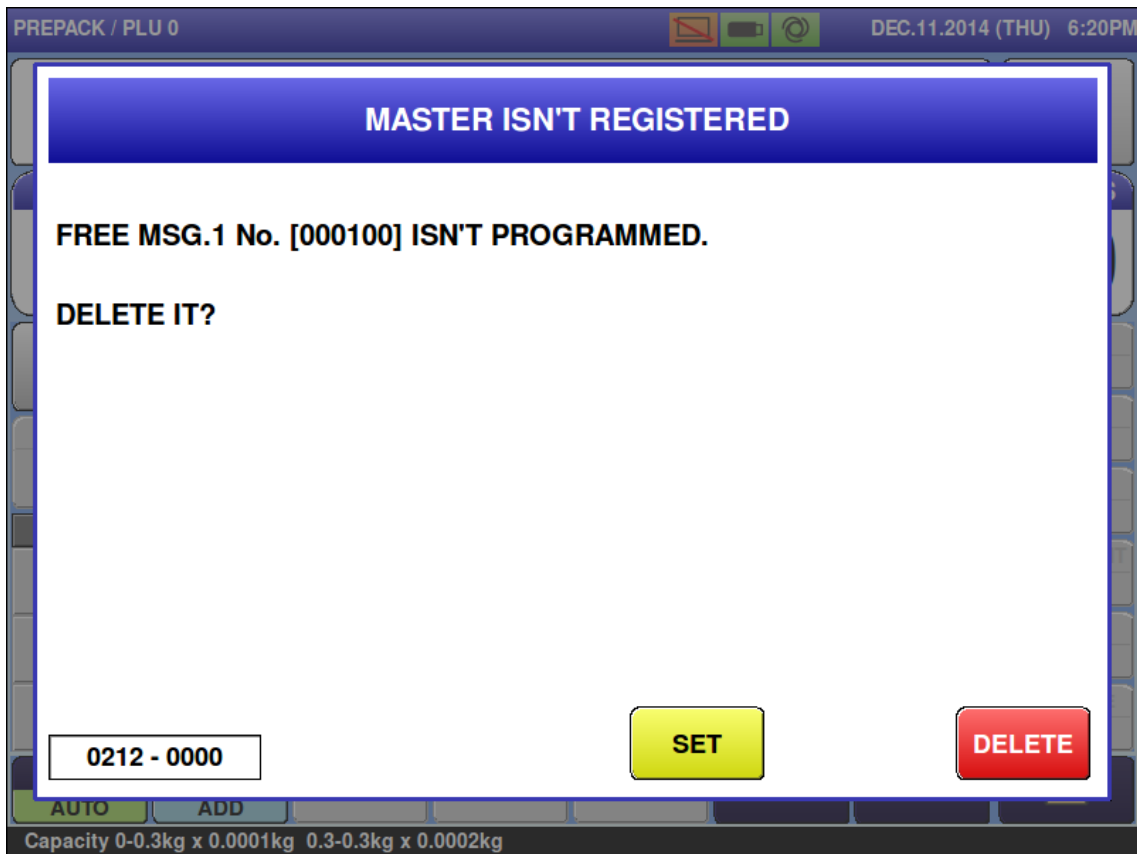

Error content	The called Free Message 1 is not found.
Detail	The message does not exist in the machine's memory.
Solution	[DELETE] button => Delete the PLU's link with the Free Message 1. [SET] button => Cancel error.
Action by user	Recheck the Free Message 1 message number. Program the Free Message 1 message.
Action by service representative	Confirm the master.
Related part	
Remarks	The error for a missing message linked to a PLU can be disabled in the Setup menu > Error Process > Call tab.

■ Free 2 master is not registered (0213)

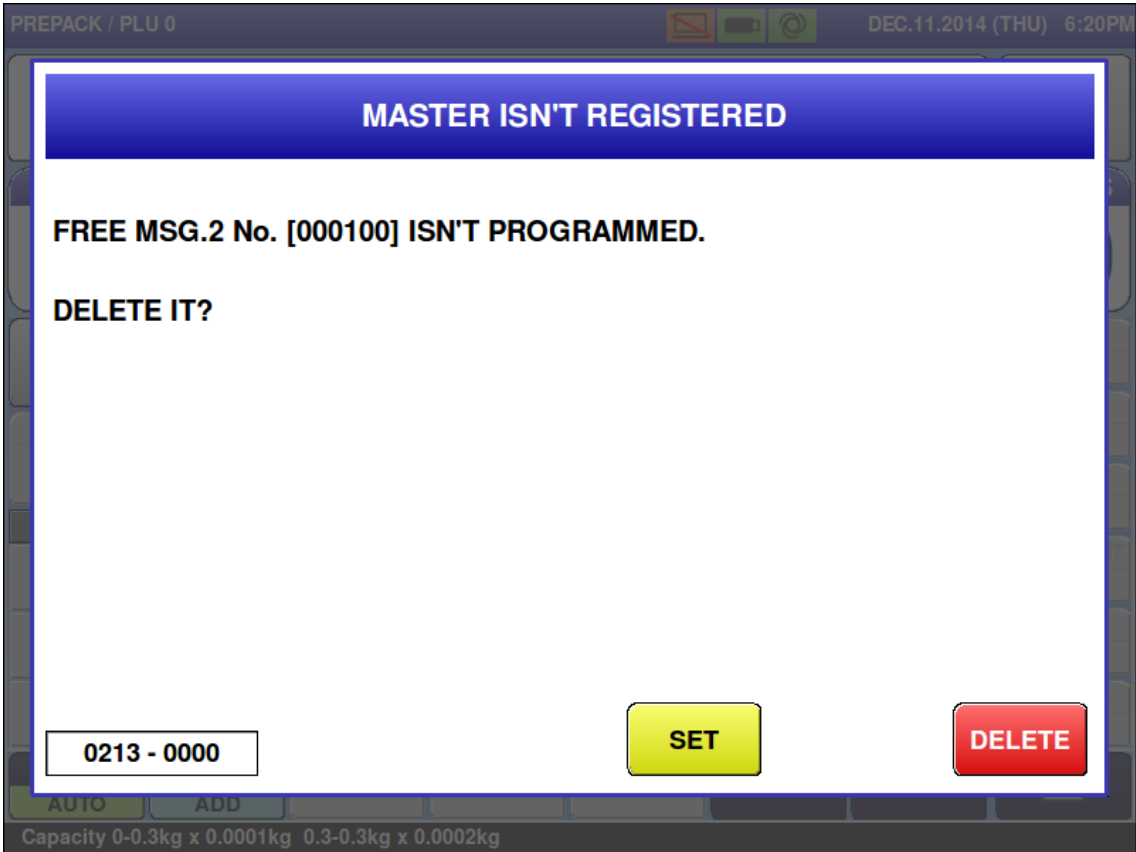

Error content	The called Free Message 2 is not found.
Detail	The message does not exist in the machine's memory.
Solution	[DELETE] button => Delete the PLU's link with the Free Message 2. [SET] button => Cancel error.
Action by user	Recheck the Free Message 2 message number. Program the Free Message 2 message.
Action by service representative	Confirm the master.
Related part	
Remarks	The error for a missing message linked to a PLU can be disabled in the Setup menu > Error Process > Call tab.

■ Free 3 master is not registered (0214)

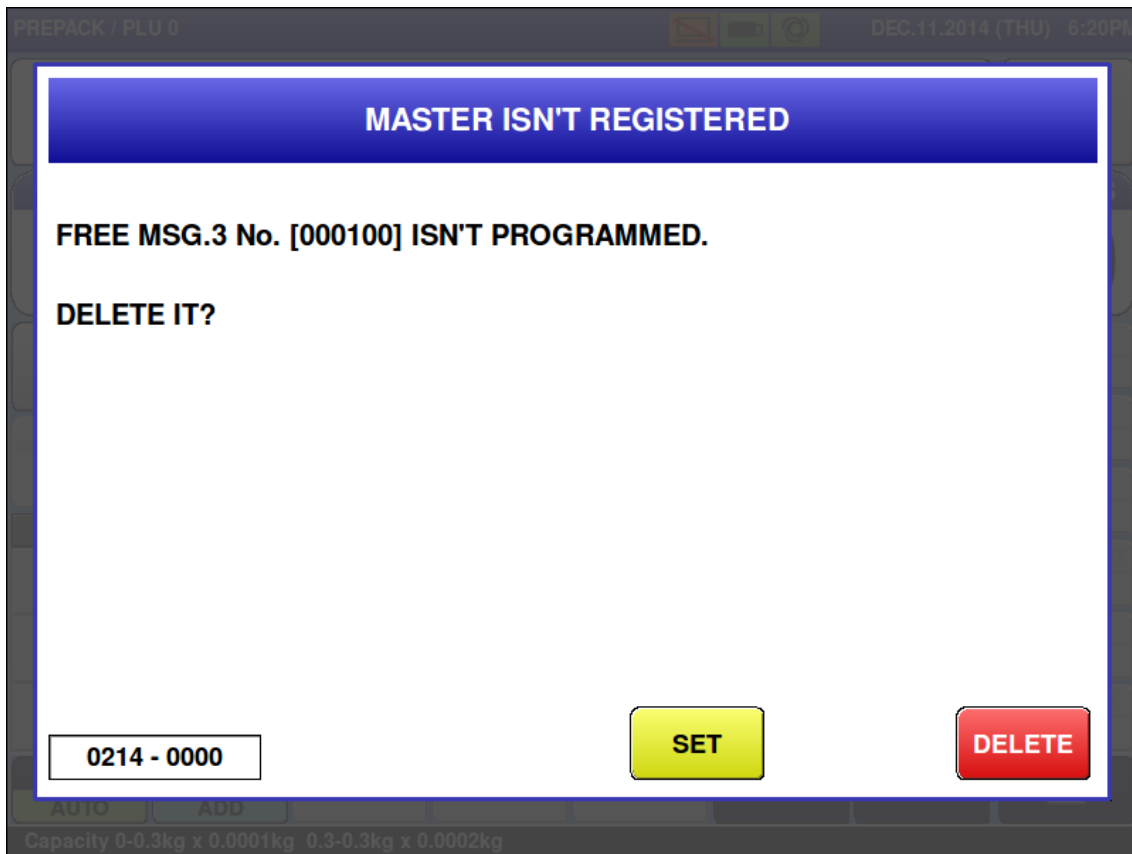

Error content	The called Free Message 3 is not found.
Detail	The message does not exist in the machine's memory.
Solution	[DELETE] button => Delete the PLU's link with the Free Message 3. [SET] button => Cancel error.
Action by user	Recheck the Free Message 3 message number. Program the Free Message 3 message.
Action by service representative	Confirm the master.
Related part	
Remarks	The error for a missing message linked to a PLU can be disabled in the Setup menu > Error Process > Call tab.

■ Free 4 master is not registered (0215)

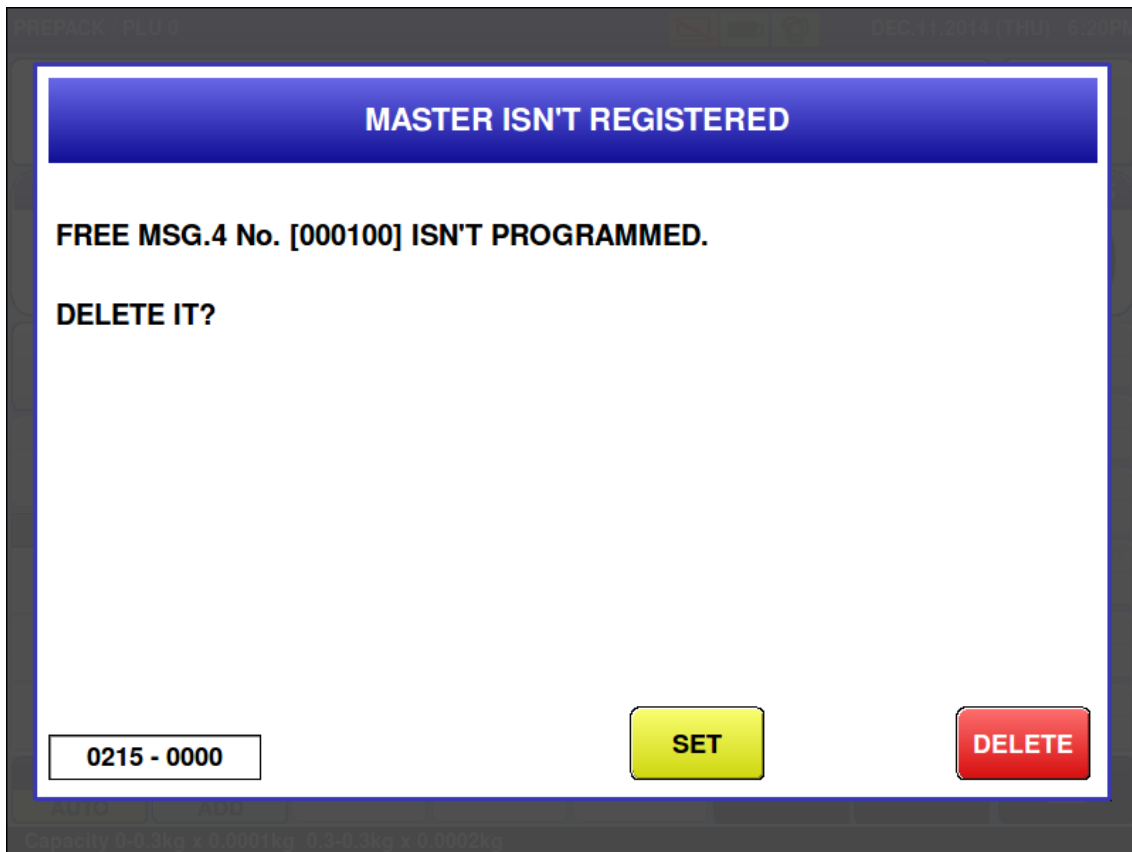

Error content	The called Free Message 4 is not found.
Detail	The message does not exist in the machine's memory.
Solution	[DELETE] button => Delete the PLU's link with the Free Message 4. [SET] button => Cancel error.
Action by user	Recheck the Free Message 4 message number. Program the Free Message 4 message.
Action by service representative	Confirm the master.
Related part	
Remarks	The error for a missing message linked to a PLU can be disabled in the Setup menu > Error Process > Call tab.

■ Free 5 master is not registered (0216)

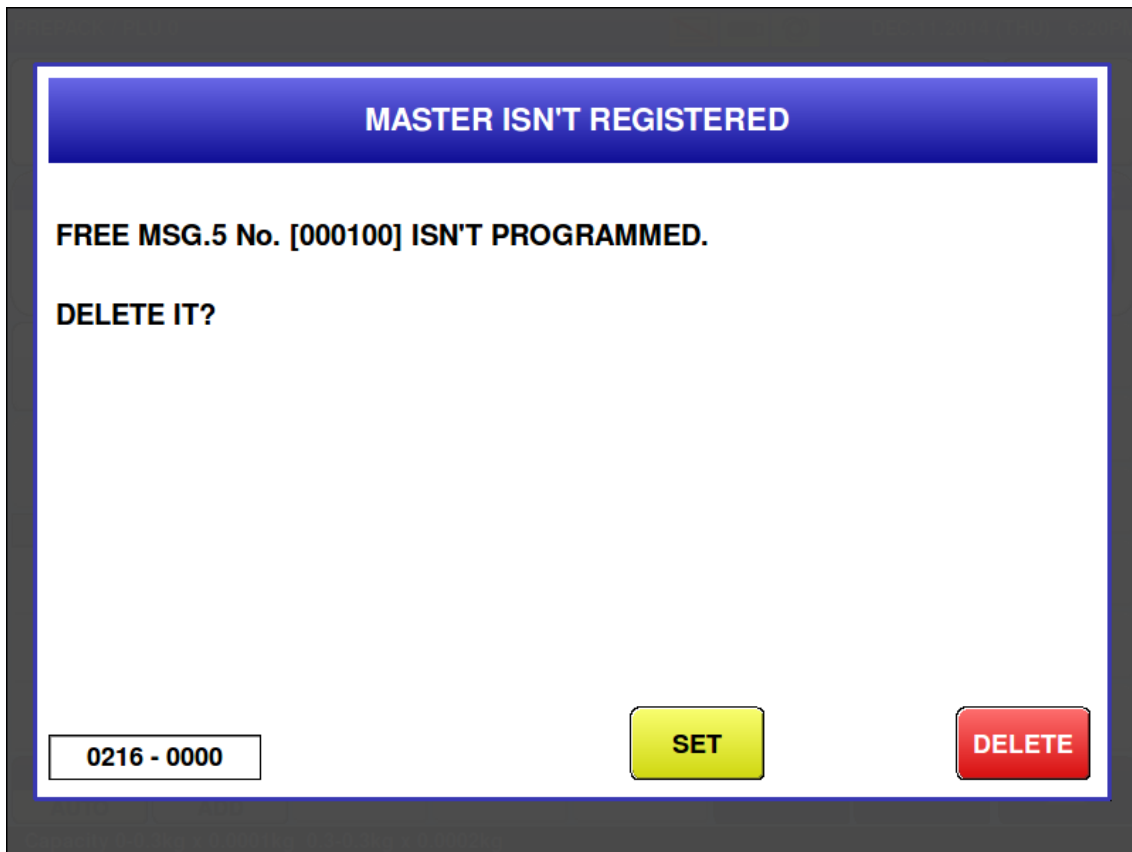

Error content	The called Free Message 5 is not found.
Detail	The message does not exist in the machine's memory.
Solution	[DELETE] button => Delete the PLU's link with the Free Message 5. [SET] button => Cancel error.
Action by user	Recheck the Free Message 5 message number. Program the Free Message 5 message.
Action by service representative	Confirm the master.
Related part	
Remarks	The error for a missing message linked to a PLU can be disabled in the Setup menu > Error Process > Call tab.

■ Amount of internal memory is short (0226)

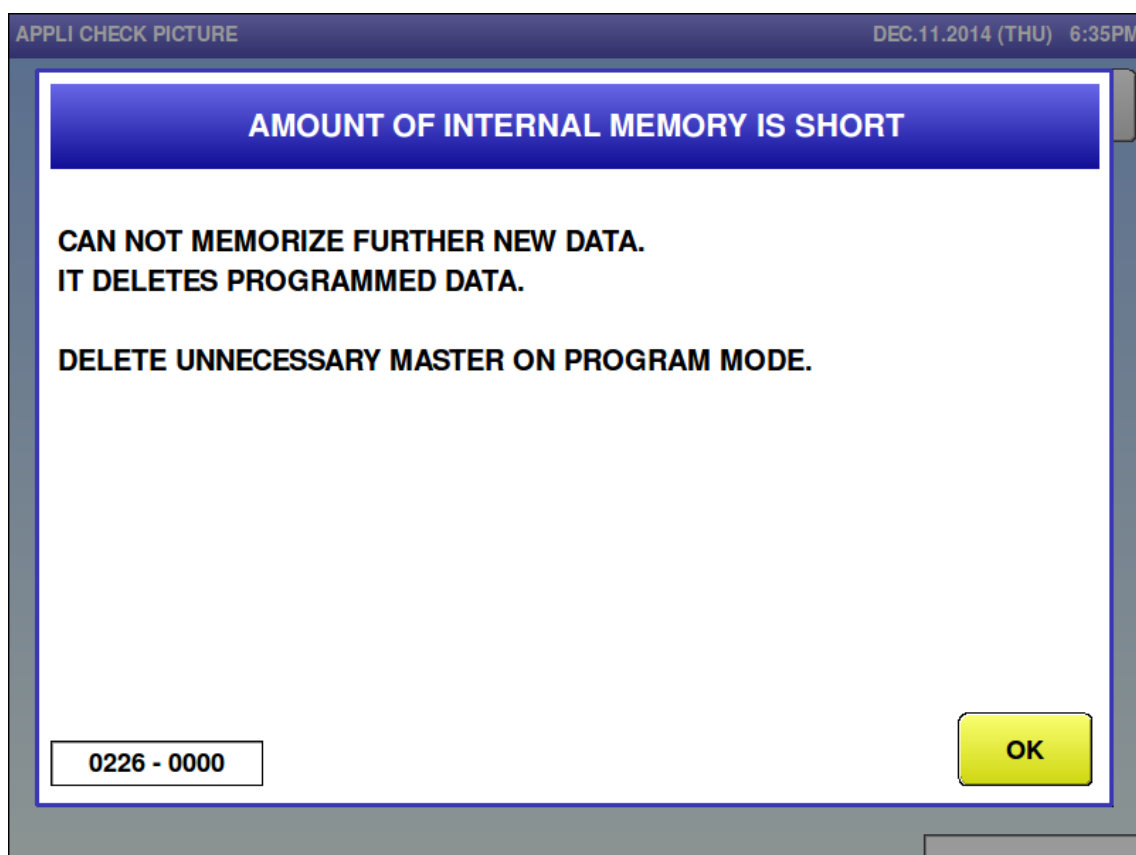

Error content	Amount of internal memory is short
Detail	Error indicates that memory space is insufficient when saving master to DB.
Solution	[OK] button, organize memory. Delete unnecessary data for each master using the "Organize Memory" function key.
Action by user	Perform Organize Memory using the [Organize Memory] function key. Delete unnecessary masters.
Action by service representative	Perform Organize Memory. Delete unnecessary masters.
Related part	Main board
Remarks	Sub error indicates each master No.

■ Amount of internal memory for total is full (0227)

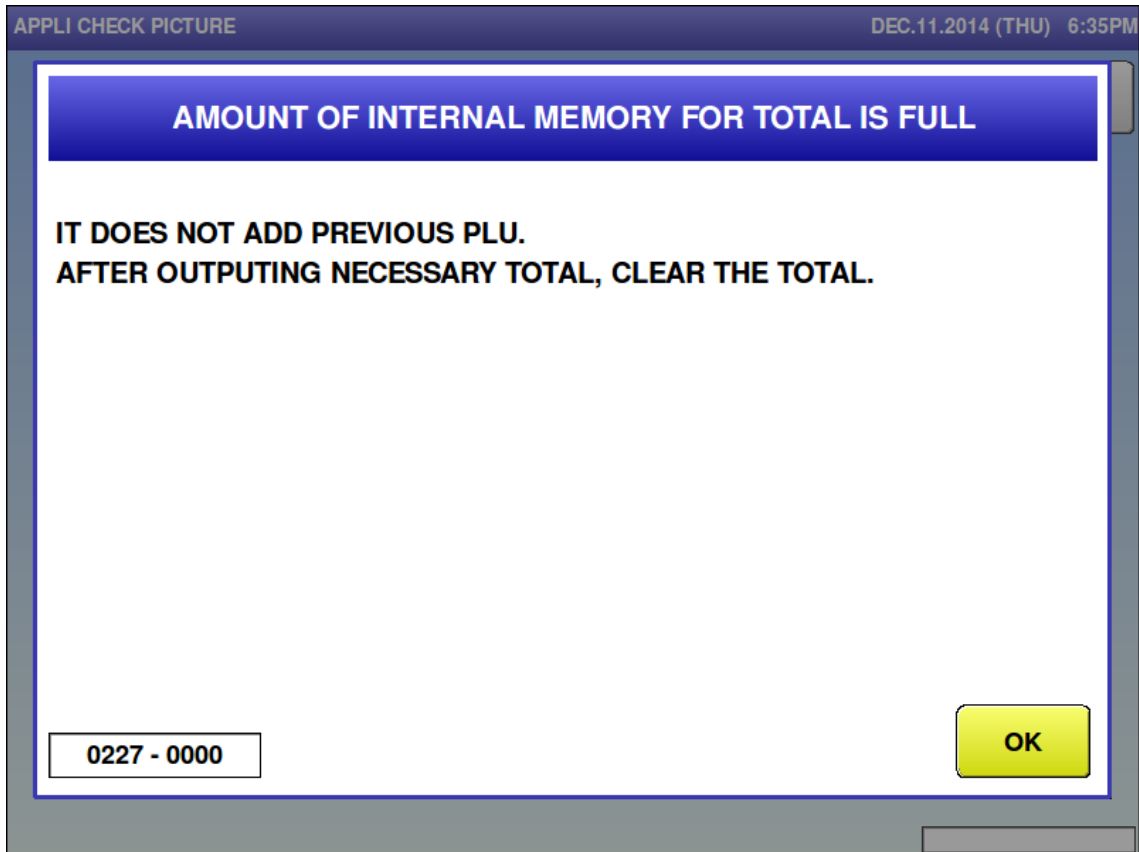

Error content	Amount of internal memory for total is full
Detail	Error indicates that internal memory is insufficient when saving production result.
Solution	[OK] button and clear the total. Organize memory using the [Organize Memory] function key.
Action by user	Perform [Organize Memory] using the [Organize Memory] function key after deleting summary data. Delete unnecessary masters.
Action by service representative	Perform [Organize Memory]. Delete unnecessary masters.
Related part	Main board
Remarks	Make sure to organize memory after clearing the total.

■ File system is abnormal (0229)

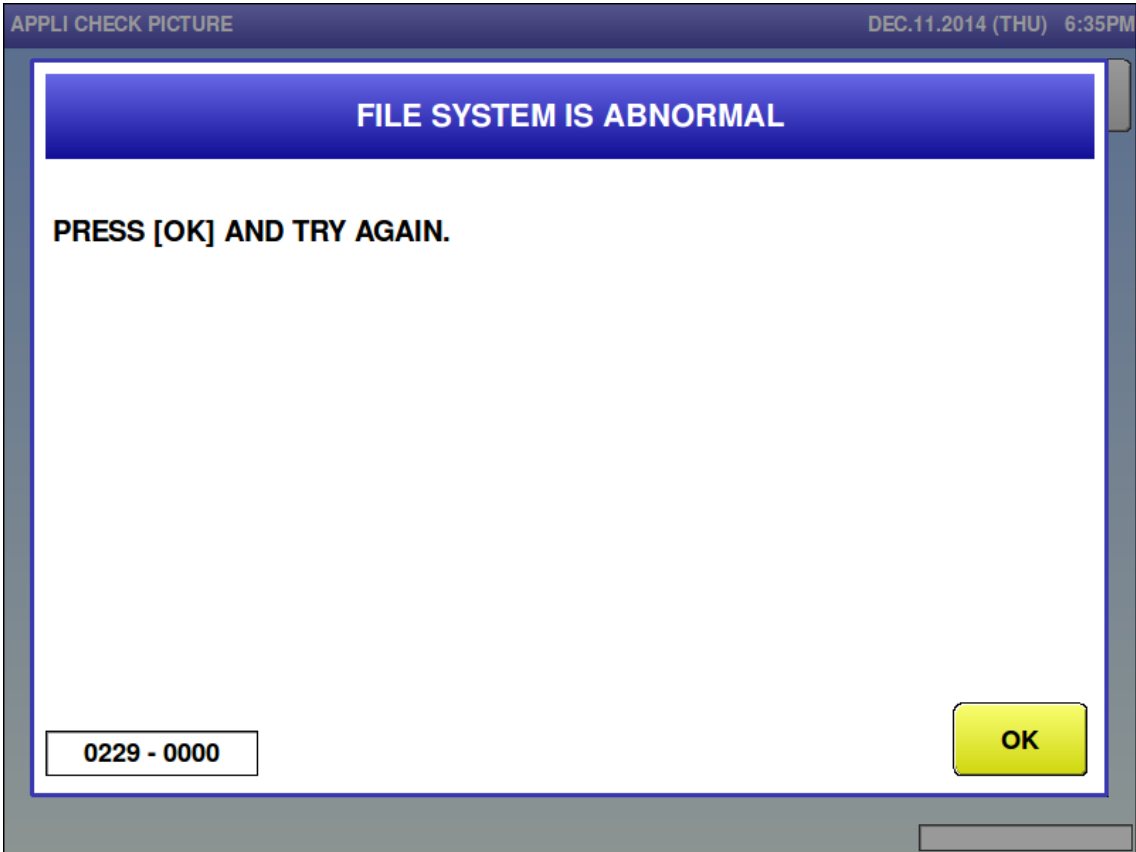

Error content	Occurs when an internal file is abnormal.
Detail	Failure of access to the program file of copy source, copy destination, and delete destination when downloading program.
Solution	[OK] button
Action by user	
Action by service representative	Confirm the internal master. Perform memory initialization. After that input the backup data.
Related part	Main board
Remarks	Check the program file of copy source, copy destination, and delete destination. 0229-0001 File System is Abnormal - Recovery from Backup indicates the memory has some corruption. When [OK] is pressed the wrapper should restore the files from its internal backup and return to normal operation. The internal backup was created the last time the scale powered down normally so the prices and other data may be out of date. If the database is corrupted it will require a memory clear to resolve. Otherwise the message will continue to recur when the scale is powered off/on. After the memory clear, reload a good USB backup then download the current data from SLP-5. A potential cause of a corrupted database is disconnecting the power without turning off the power switch and waiting for the scale to completely shut down. Or, turning the power switch off and immediately back on. It can take up to a 30 seconds to fully shut down.

■ File input error (0266—0000)

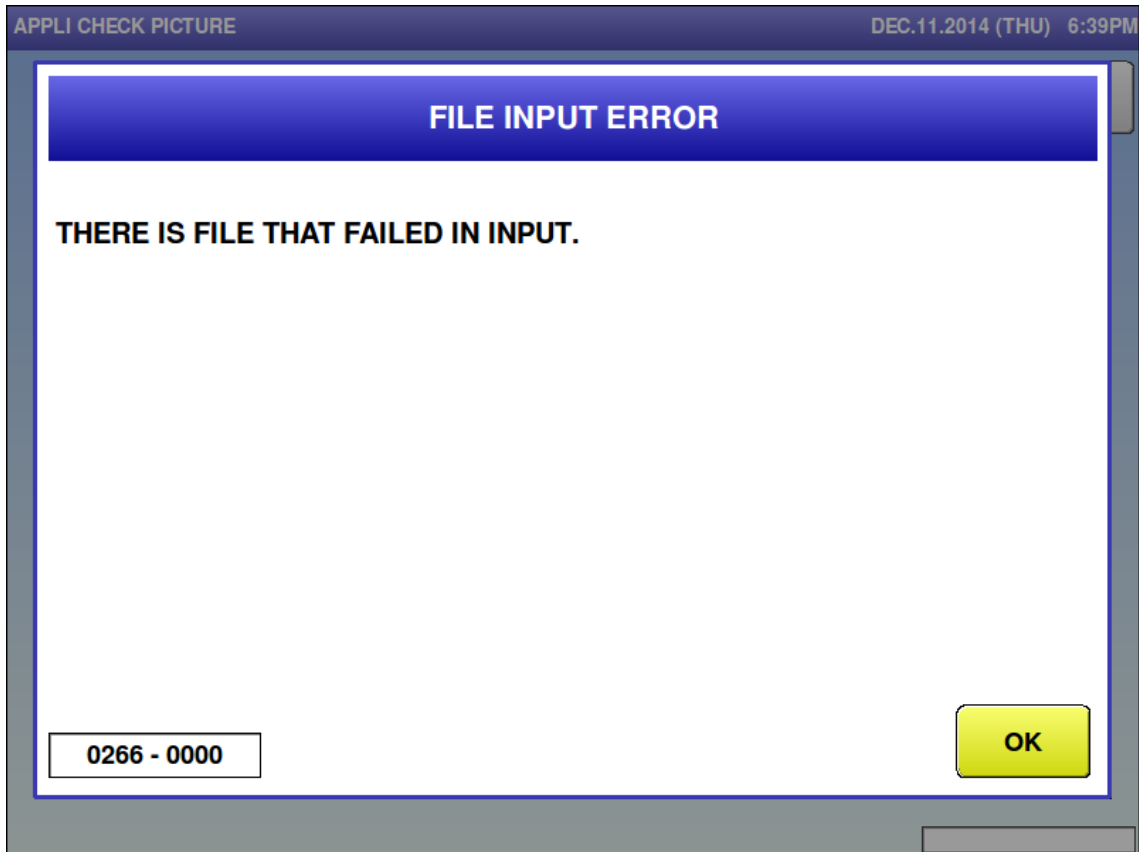

Error content	There is file that failed in input from an external device to internal memory on the [SETUP: FILE SAVE/LOAD(INPUT) screen.
Detail	Input data is separated by sub-error No. 0000: Master data
Solution	[OK] button
Action by user	
Action by service representative	Confirm the internal master data.
Related part	Main board
Remarks	Check the source data file and reload from a different source file if needed.

■ File input error (0266—0001)

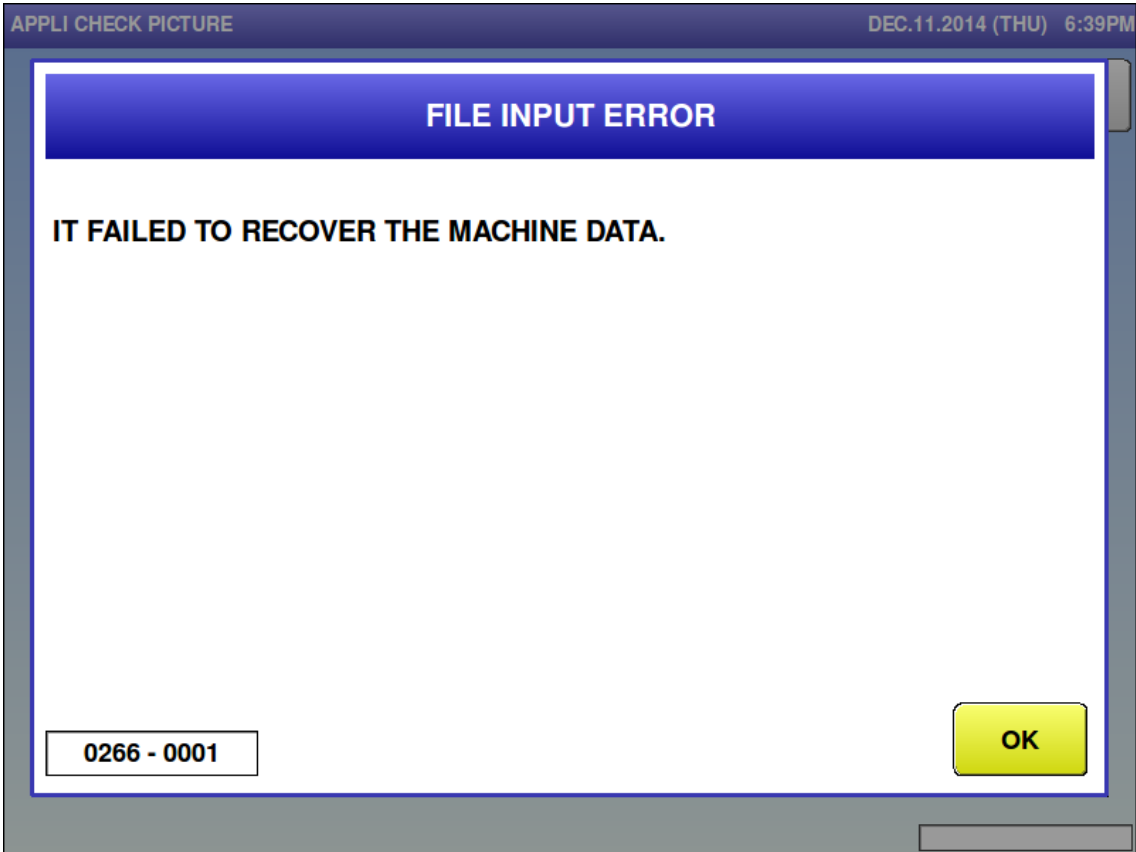

Error content	There is file that failed in input from an external device to internal memory on the [SETUP: FILE SAVE/LOAD(INPUT) screen.
Detail	Input data is separated by sub-error No. 0001: SRAM data
Solution	[OK] button
Action by user	
Action by service representative	Confirm the internal master data.
Related part	Main board
Remarks	Check the source data file and reload from a different source file if needed.

■ File input error (0266—0002)

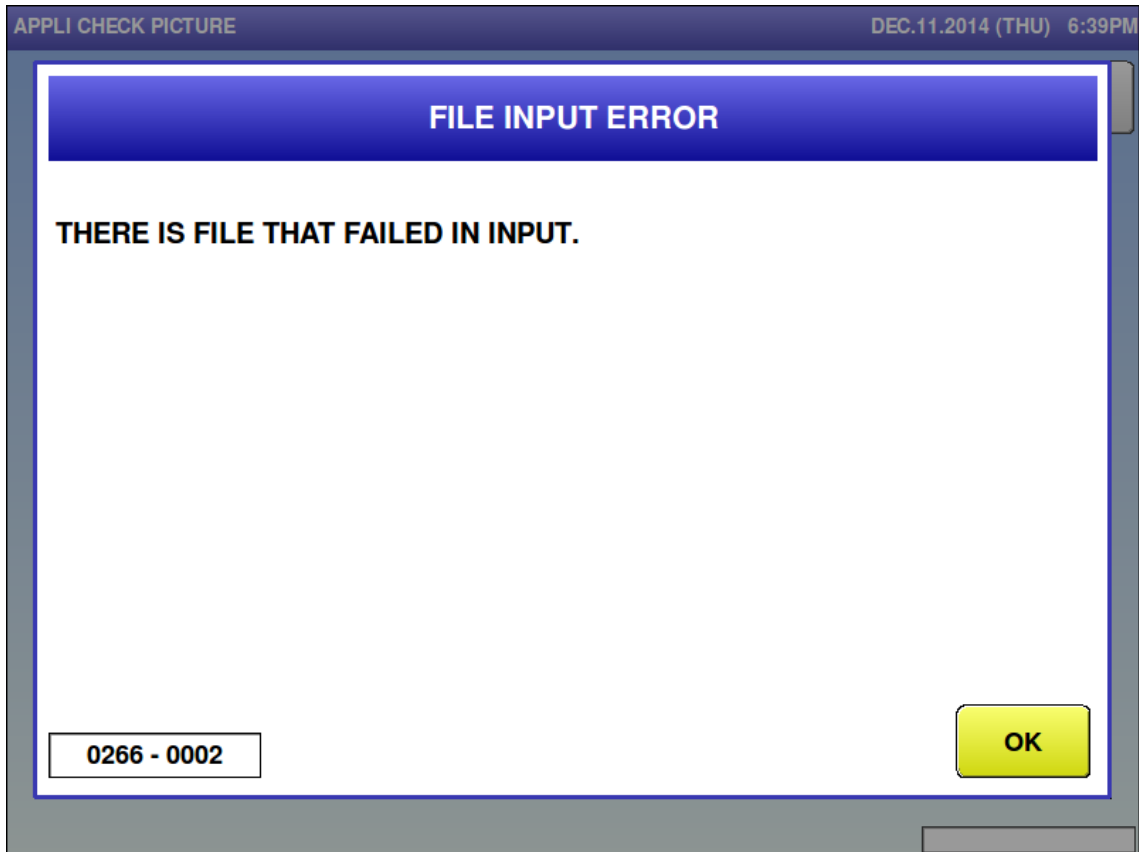

Error content	There is file that failed in input from an external device to internal memory on the [SETUP: FILE SAVE/LOAD(INPUT) screen.
Detail	Input data is separated by sub-error No. 0002: Master data (all master)
Solution	[OK] button
Action by user	
Action by service representative	Confirm the internal master data.
Related part	Main board
Remarks	Check the source data file and reload from a different source file if needed.

■ File output error (0267–0000)

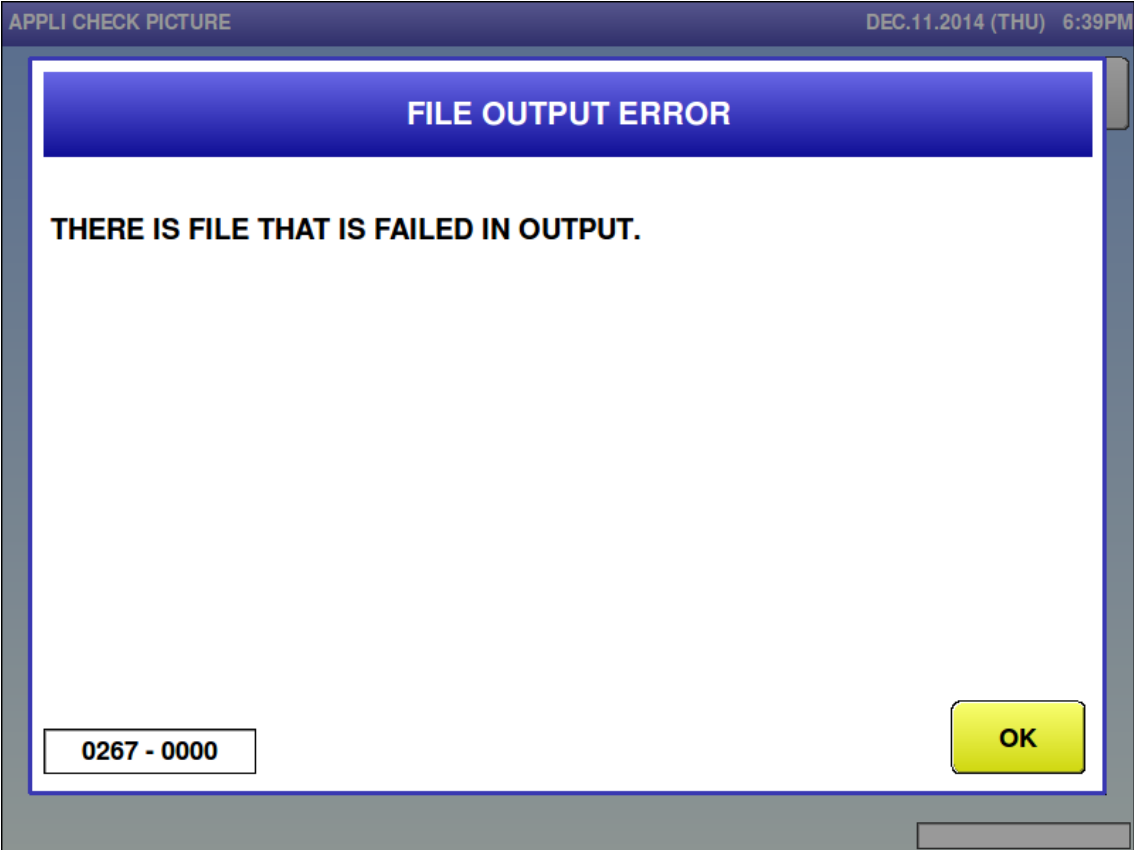

Error content	There is file that failed in output from internal memory to an external device on the [SETUP: FILE SAVE/LOAD(OUTPUT)] screen.
Detail	Output source data is separated by sub-error No. 0000: Master data
Solution	[OK] button
Action by user	
Action by service representative	Confirm the internal master data.
Related part	Main board
Remarks	Check the recording device.

■ File output error (0267–0001)

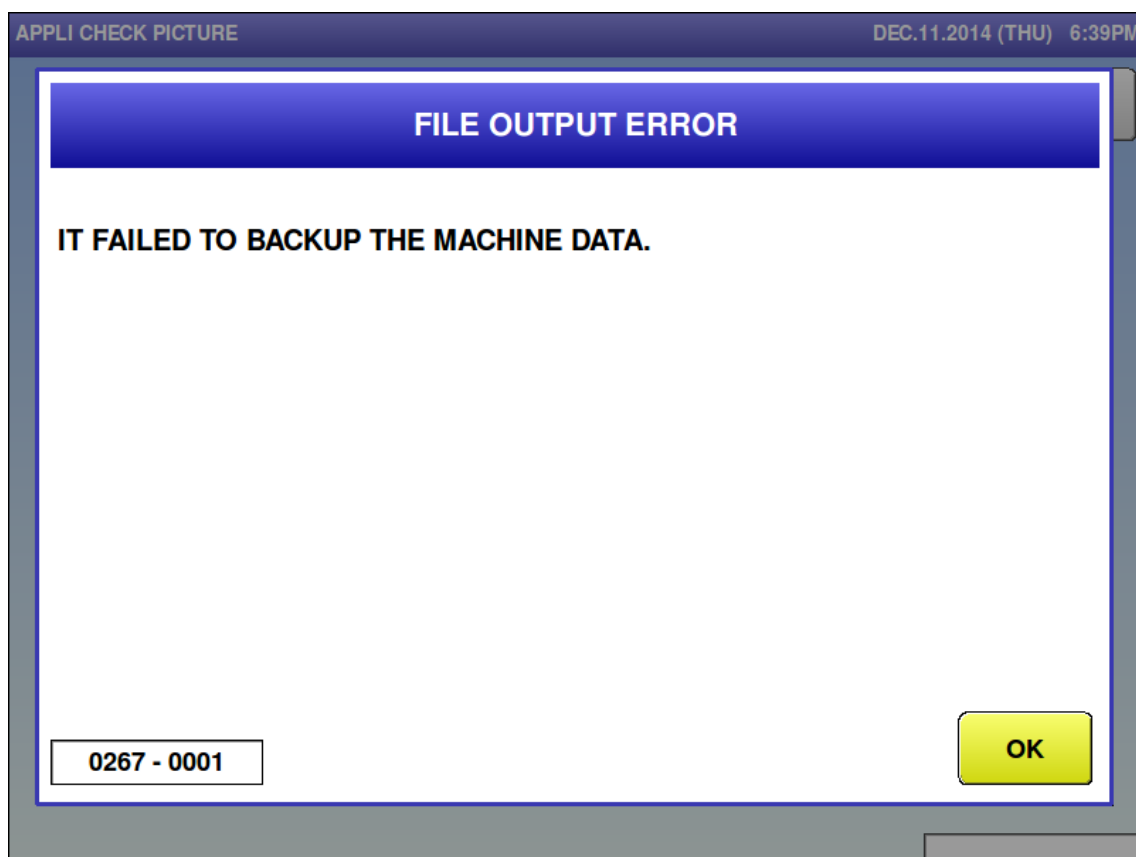

Error content	There is file that failed in output from internal memory to an external device on the [SETUP: FILE SAVE/LOAD(OUTPUT)] screen.
Detail	Output source data is separated by sub-error No. 0001: SRAM data
Solution	[OK] button
Action by user	
Action by service representative	Confirm the internal master data.
Related part	Main board
Remarks	Check the recording device.

■ File output error (0267–0002)

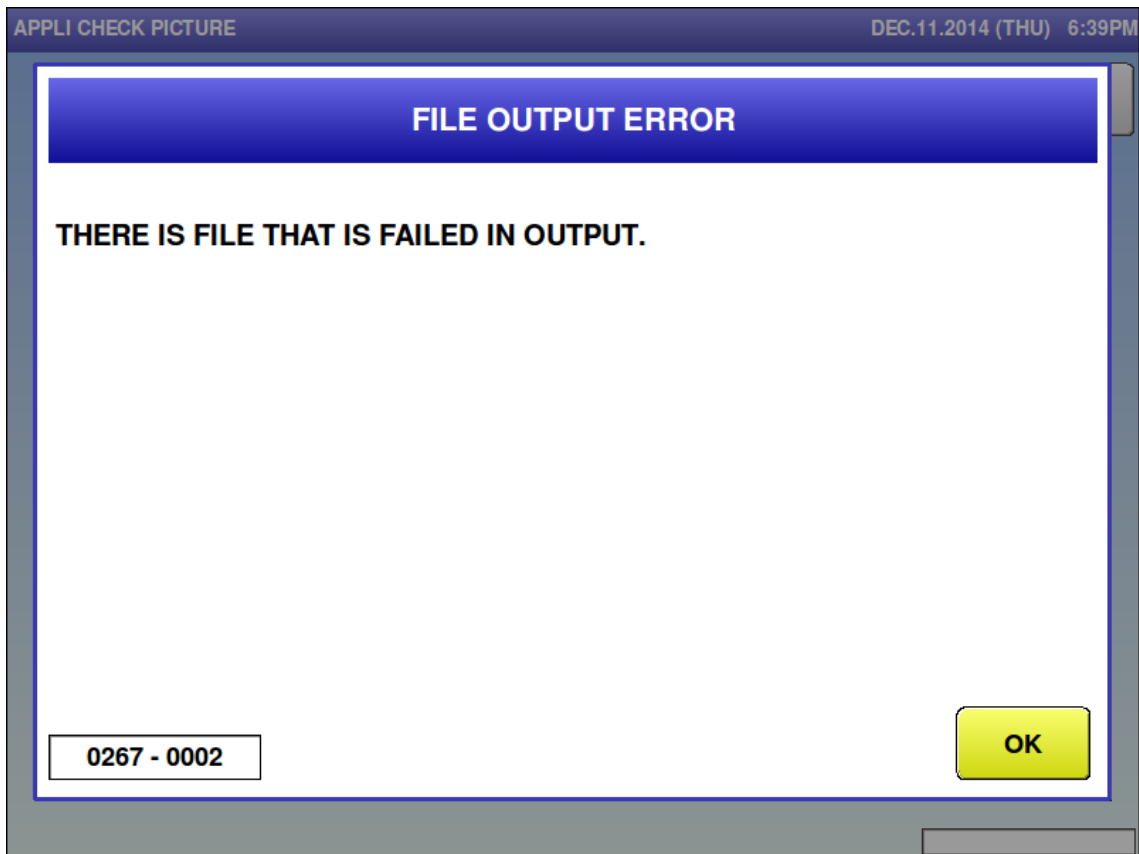

Error content	There is file that failed in output from internal memory to an external device on the [SETUP: FILE SAVE/LOAD(OUTPUT)] screen.
Detail	Output source data is separated by sub-error No. 0002: Master data (all master)
Solution	[OK] button
Action by user	
Action by service representative	Confirm the internal master data.
Related part	Main board
Remarks	Check the recording device.

■ File delete error (0268—0000)

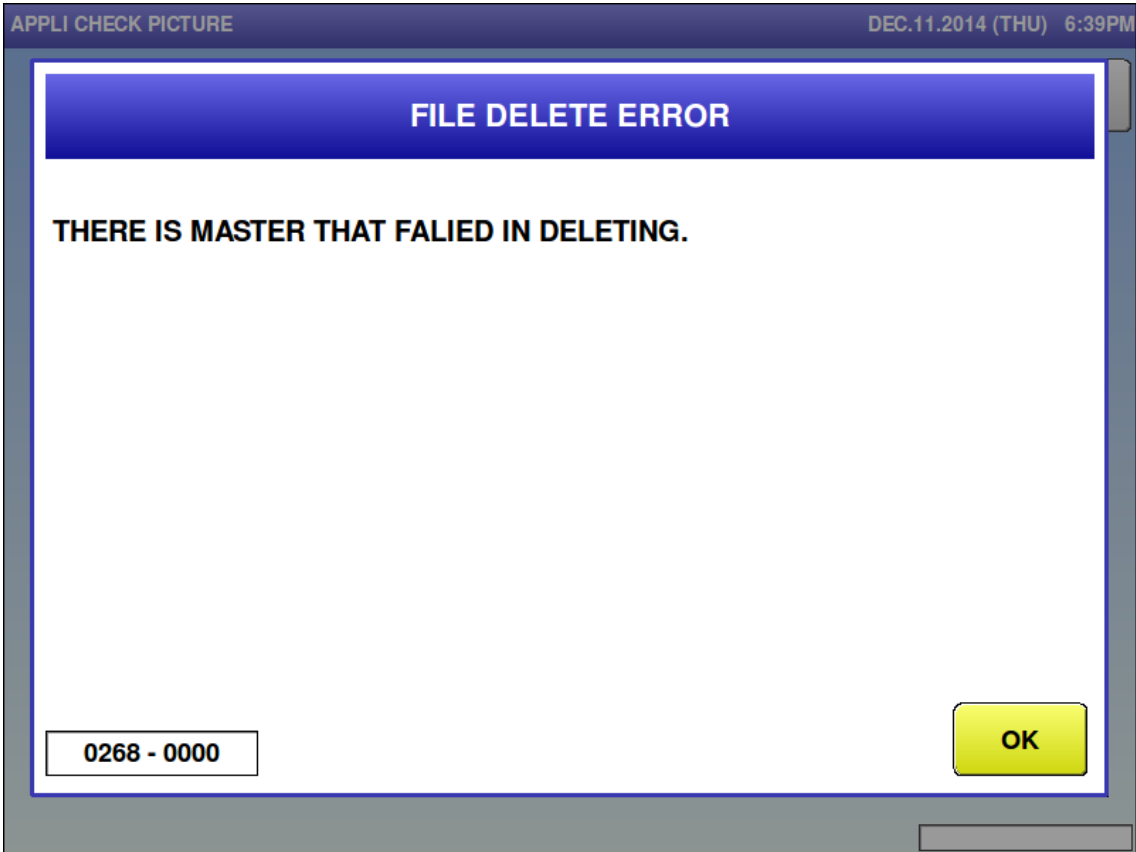

Error content	There is external device data or SRAM data that failed in deleting on the [SETUP: FILE SAVE/LOAD(DELETE)] screen.
Detail	Data to delete is separated by sub-error No. 0000: External device data (master specified)
Solution	[OK] button
Action by user	
Action by service representative	Confirm the internal master data.
Related part	Main board
Remarks	Check the recording device.

■ File delete error (0268—0001)

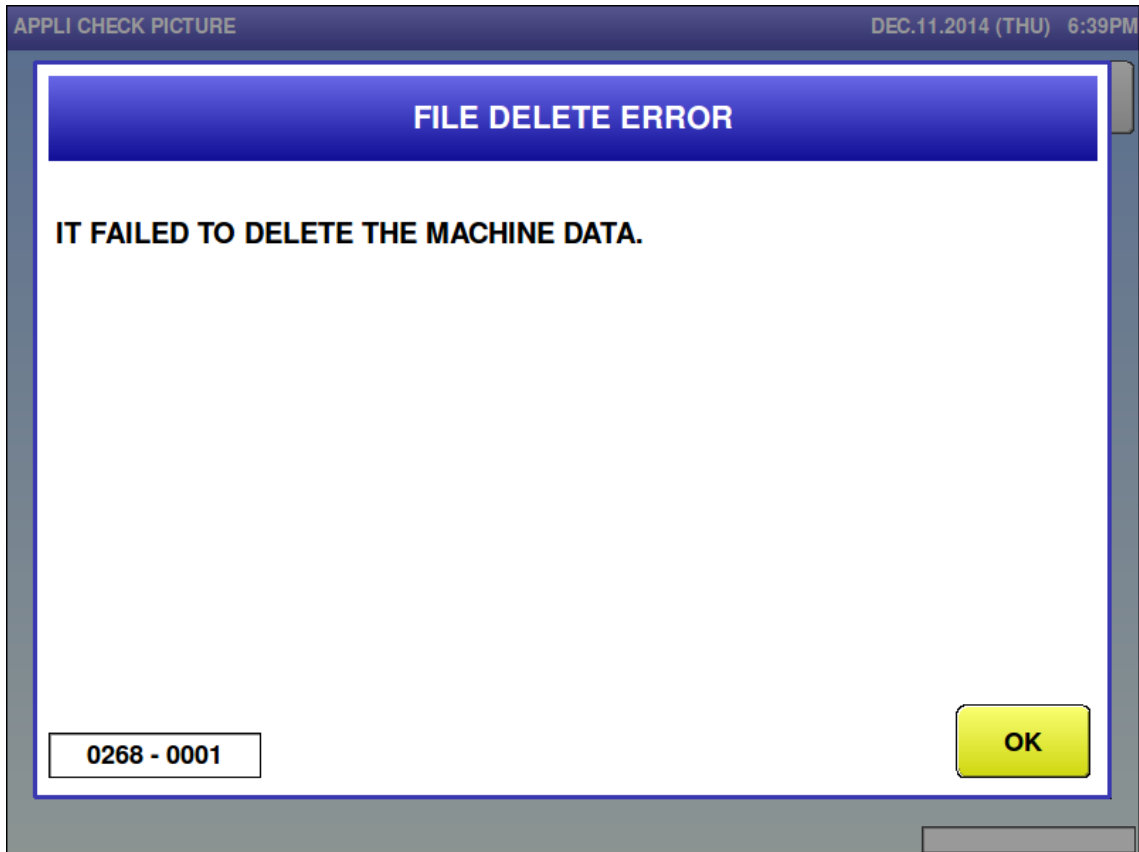

Error content	There is external device data or SRAM data that failed in deleting on the [SETUP: FILE SAVE/LOAD(DELETE)] screen.
Detail	Data to delete is separated by sub-error No. 0001: SRAM data
Solution	[OK] button
Action by user	
Action by service representative	Confirm the internal master data.
Related part	Main board
Remarks	Check the recording device.

■ File delete error (0268—0002)

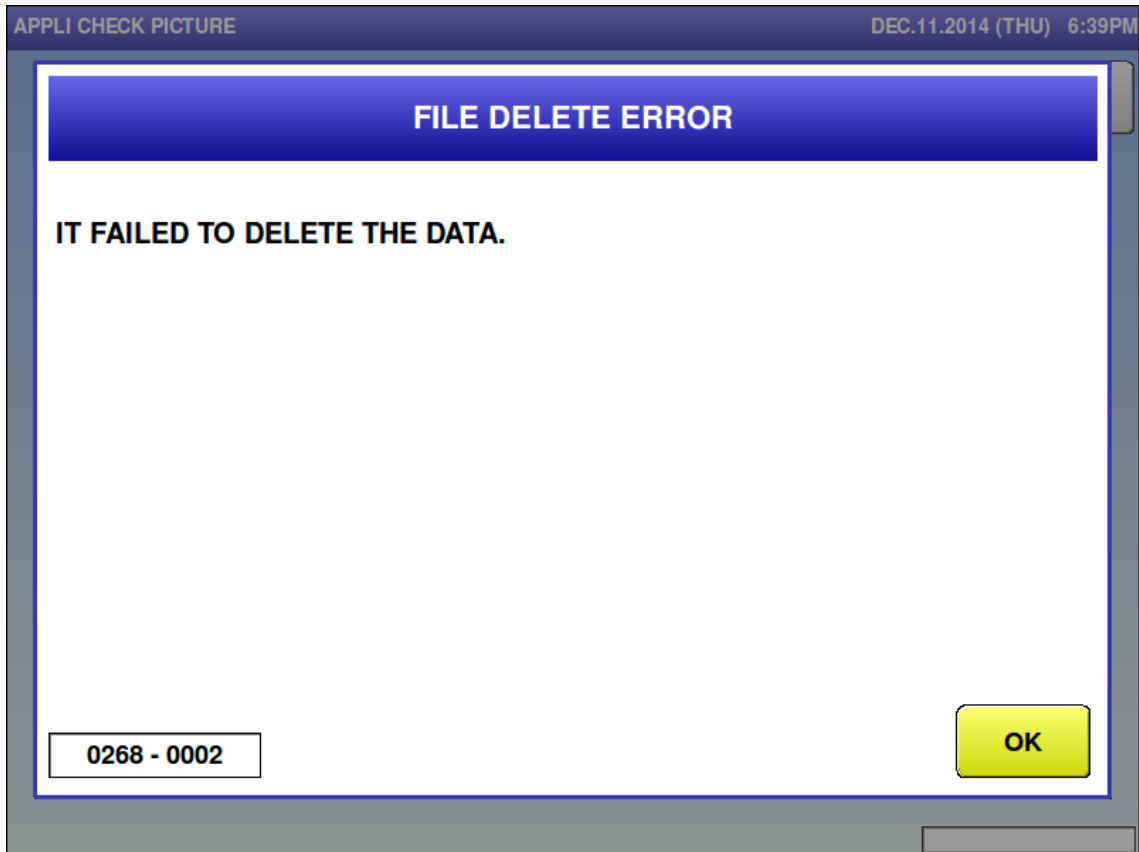

Error content	There is external device data or SRAM data that failed in deleting on the [SETUP: FILE SAVE/LOAD(DELETE)] screen.
Detail	Data to delete is separated by sub-error No. 0002: External device data (data specified)
Solution	[OK] button
Action by user	
Action by service representative	Confirm the internal master data.
Related part	Main board
Remarks	Check the recording device.

■ File delete error (0268—0003)

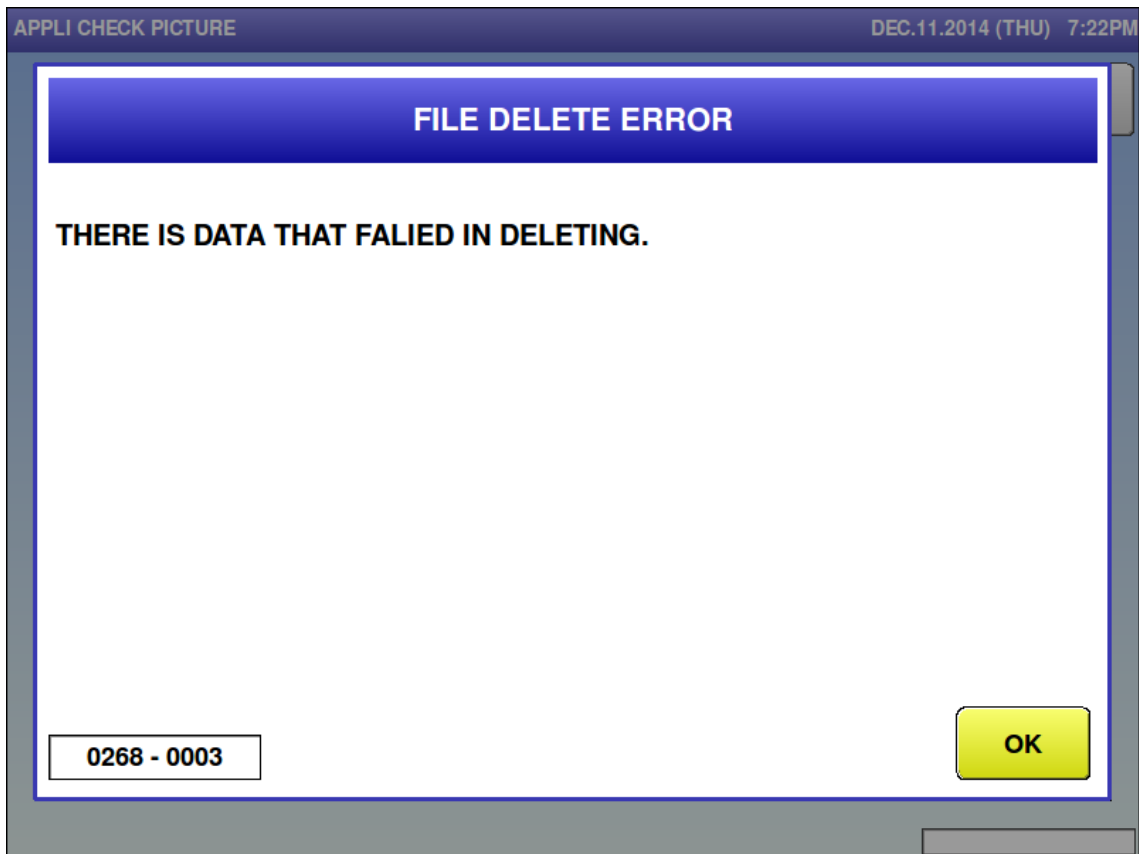

Error content	There is external device data or SRAM data that failed in deleting on the [SETUP: FILE SAVE/LOAD(DELETE)] screen.
Detail	Data to delete is separated by sub-error No. 0003: External device data (all data)
Solution	[OK] button
Action by user	
Action by service representative	Confirm the internal master data.
Related part	Main board
Remarks	Check the recording device.

- Initialize error (0271)

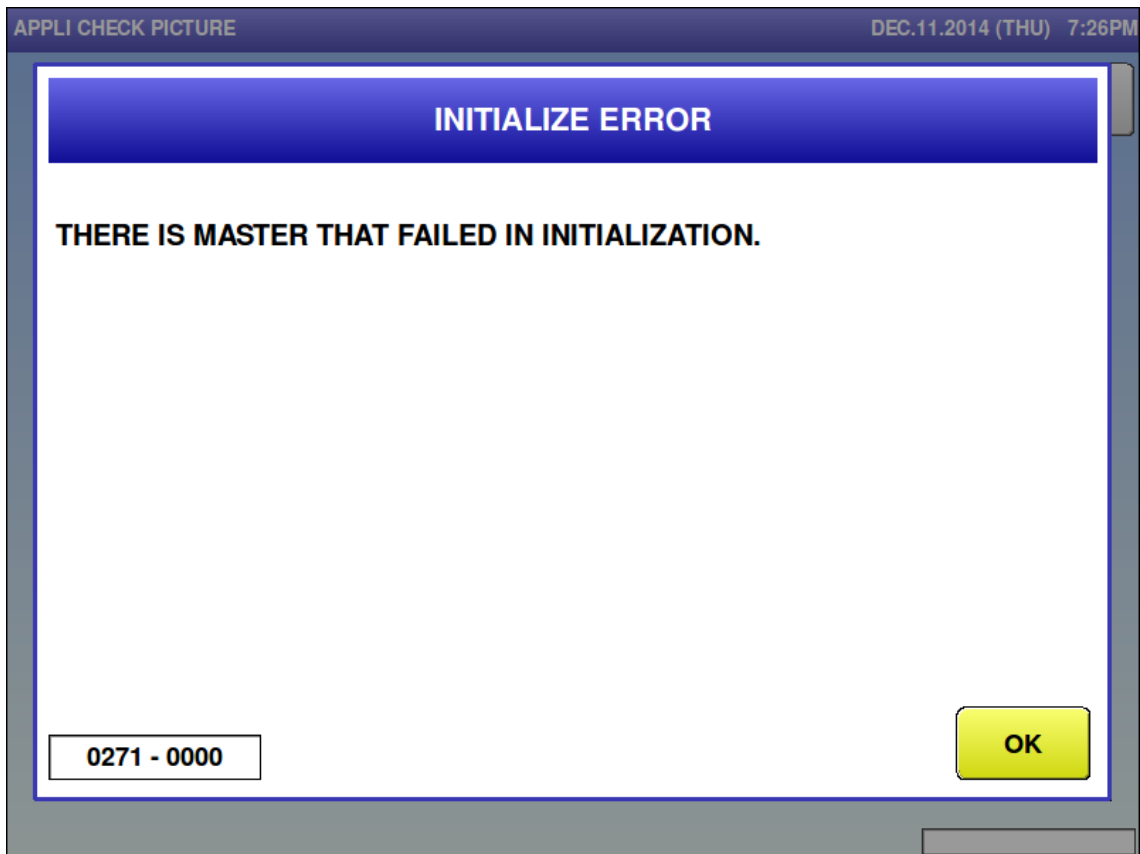

Error content	There is internal master that failed in initialization on the [SETUP: FILE SAVE/LOAD(INIT.)] screen.
Detail	
Solution	[OK] button
Action by user	
Action by service representative	Confirm the internal master data.
Related part	Main board
Remarks	

- Extra message 1 master is not programmed (0286)

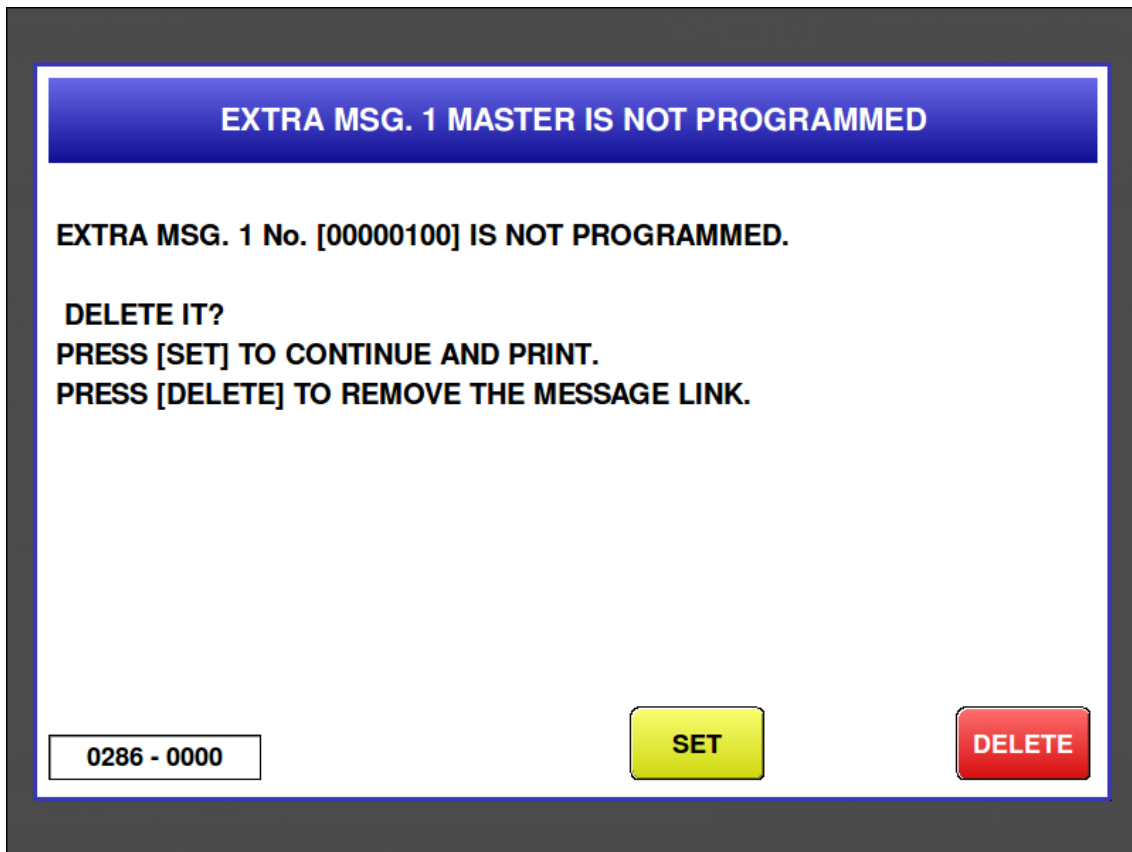

Error content	The called Extra Message 1 is not found.
Detail	The message does not exist in the machine's memory.
Solution	[DELETE] button => Delete the PLU's link with the Extra Message 1. [SET] button => Cancel error.
Action by user	Recheck the Extra Message 1 message number. Program the Extra Message 1 message.
Action by service representative	Confirm the master.
Related part	Main board
Remarks	The error for a missing message linked to a PLU can be disabled in the Setup menu > Error Process > Call tab.

■ Ingredient master is not programmed (0287)

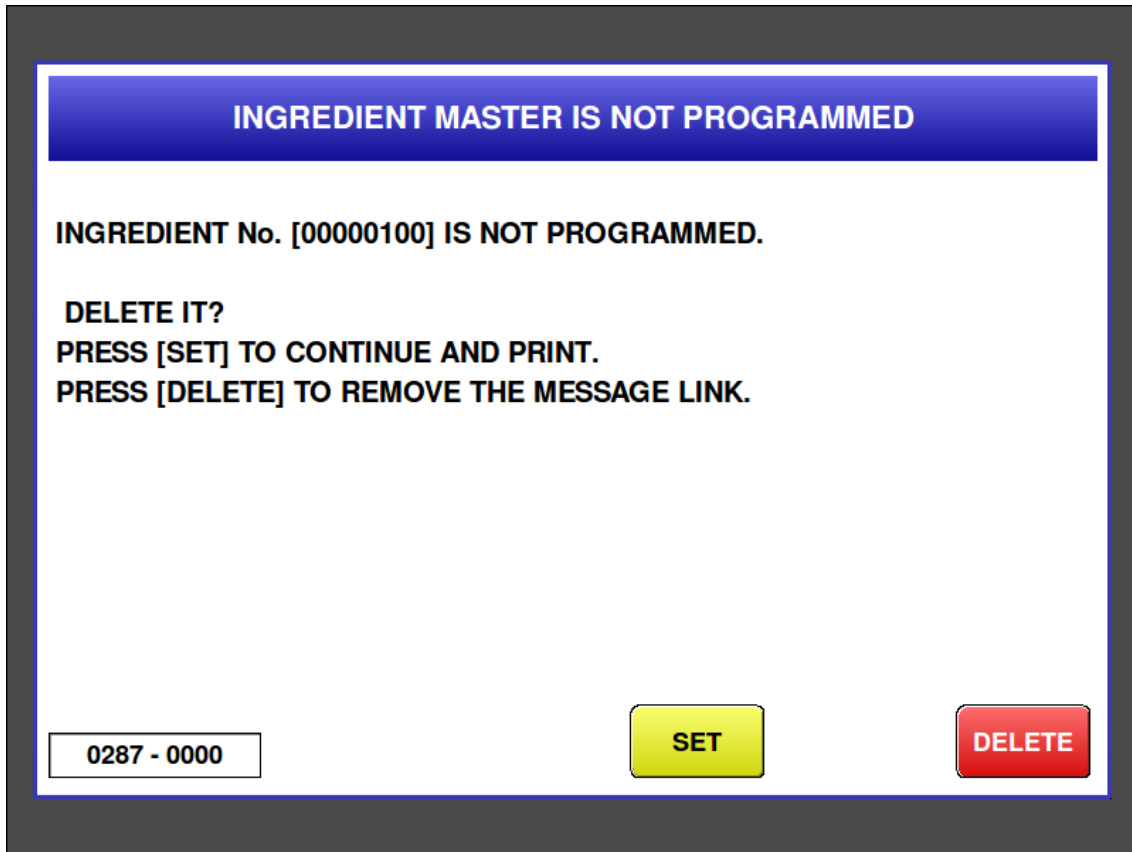

Error content	The called Ingredient Message is not found.
Detail	The message does not exist in the machine's memory.
Solution	[DELETE] button => Delete the PLU's link with the Ingredient Message. [SET] button => Cancel error.
Action by user	Recheck the Ingredient message number. Program the Ingredient message.
Action by service representative	Confirm the master.
Related part	Main board
Remarks	The error for a missing message linked to a PLU can be disabled in the Setup menu > Error Process > Call tab.

- Extra message 3 master is not programmed (0289)

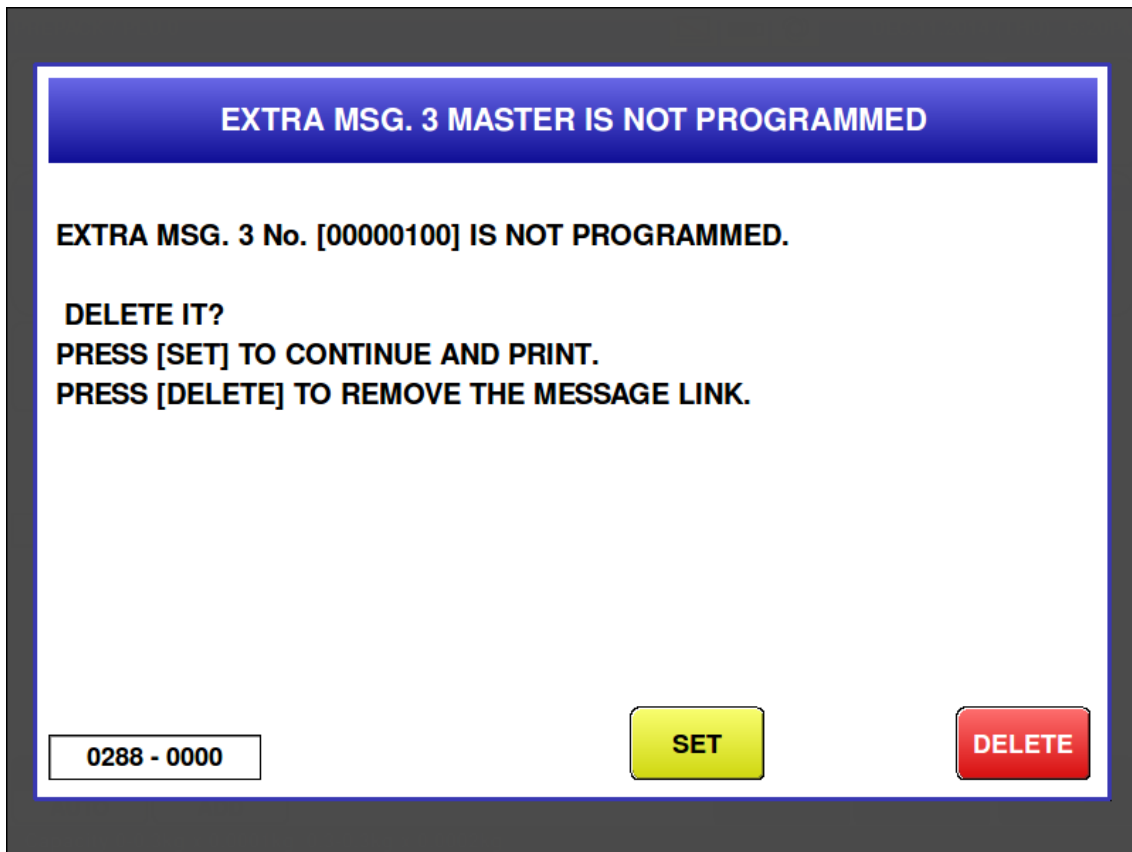

Error content	The called Extra Message 3 is not found.
Detail	The message does not exist in the machine's memory.
Solution	[DELETE] button => Delete the PLU's link with the Extra Message 3. [SET] button => Cancel error.
Action by user	Recheck the Extra Message 3 message number. Program the Extra Message 3 message.
Action by service representative	Confirm the master.
Related part	Main board
Remarks	The error for a missing message linked to a PLU can be disabled in the Setup menu > Error Process > Call tab.

■ Free 6 master is not registered (0294)

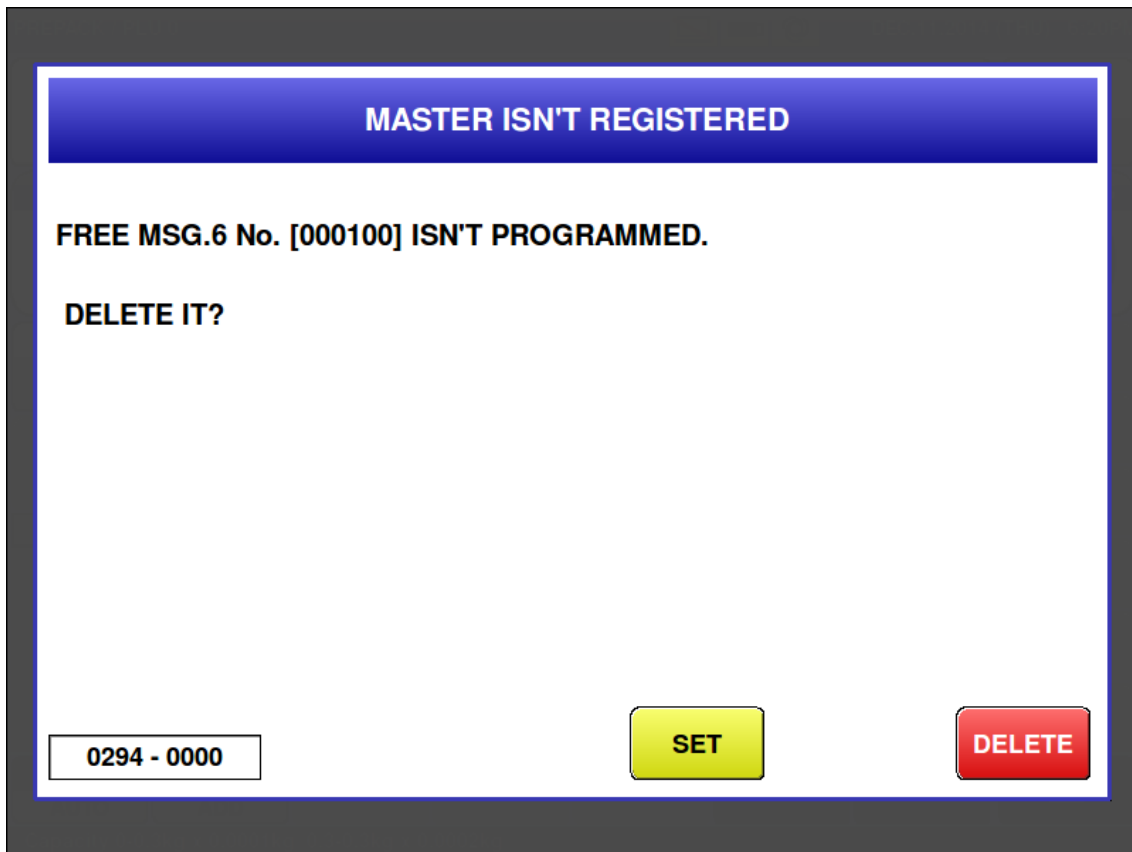

Error content	The called Free Message 6 is not found.
Detail	The message does not exist in the machine's memory.
Solution	[DELETE] button => Delete the PLU's link with the Free Message 6. [SET] button => Cancel error.
Action by user	Recheck the Free Message 6 message number. Program the Free Message 6 message.
Action by service representative	Confirm the master.
Related part	Main board
Remarks	The error for a missing message linked to a PLU can be disabled in the Setup menu > Error Process > Call tab.

■ Free 7 master is not registered (0295)

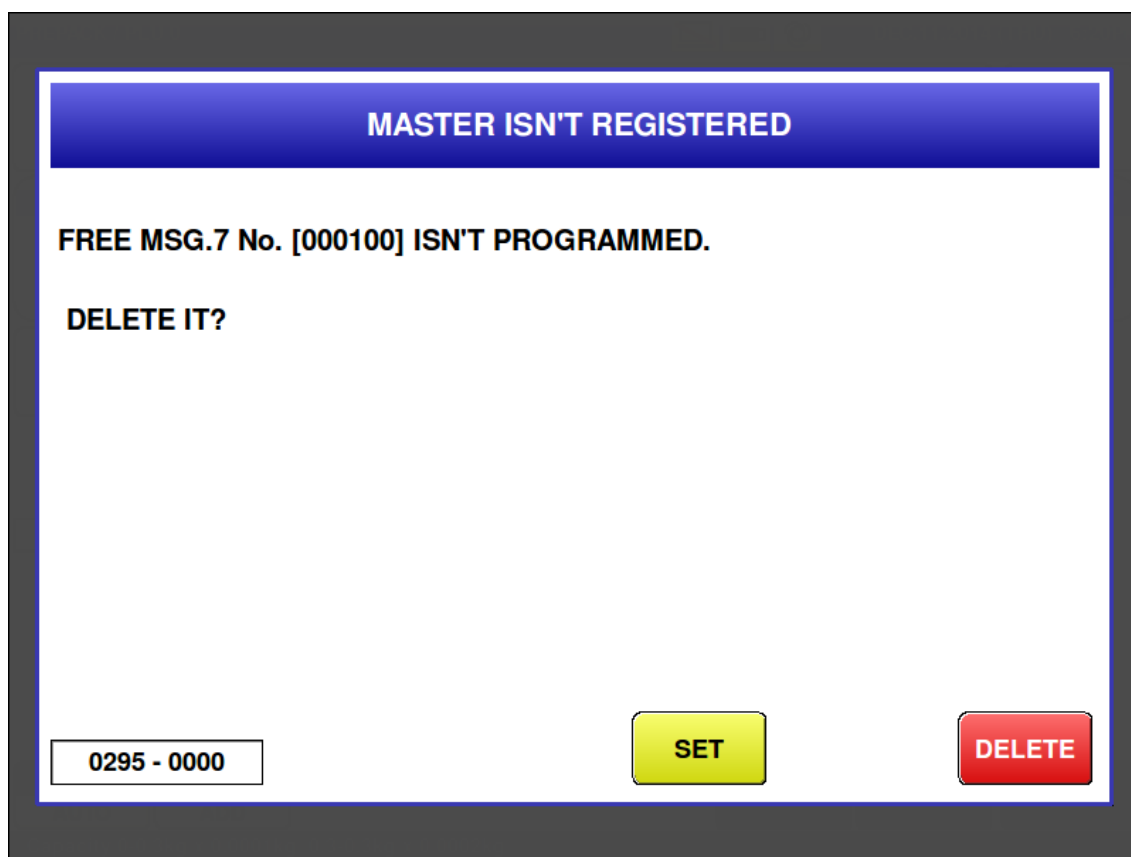

Error content	The called Free Message 7 is not found.
Detail	The message does not exist in the machine's memory.
Solution	[DELETE] button => Delete the PLU's link with the Free Message 7. [SET] button => Cancel error.
Action by user	Recheck the Free Message 7 message number. Program the Free Message 7 message.
Action by service representative	Confirm the master.
Related part	Main board
Remarks	The error for a missing message linked to a PLU can be disabled in the Setup menu > Error Process > Call tab.

■ Free 8 master is not registered (0296)

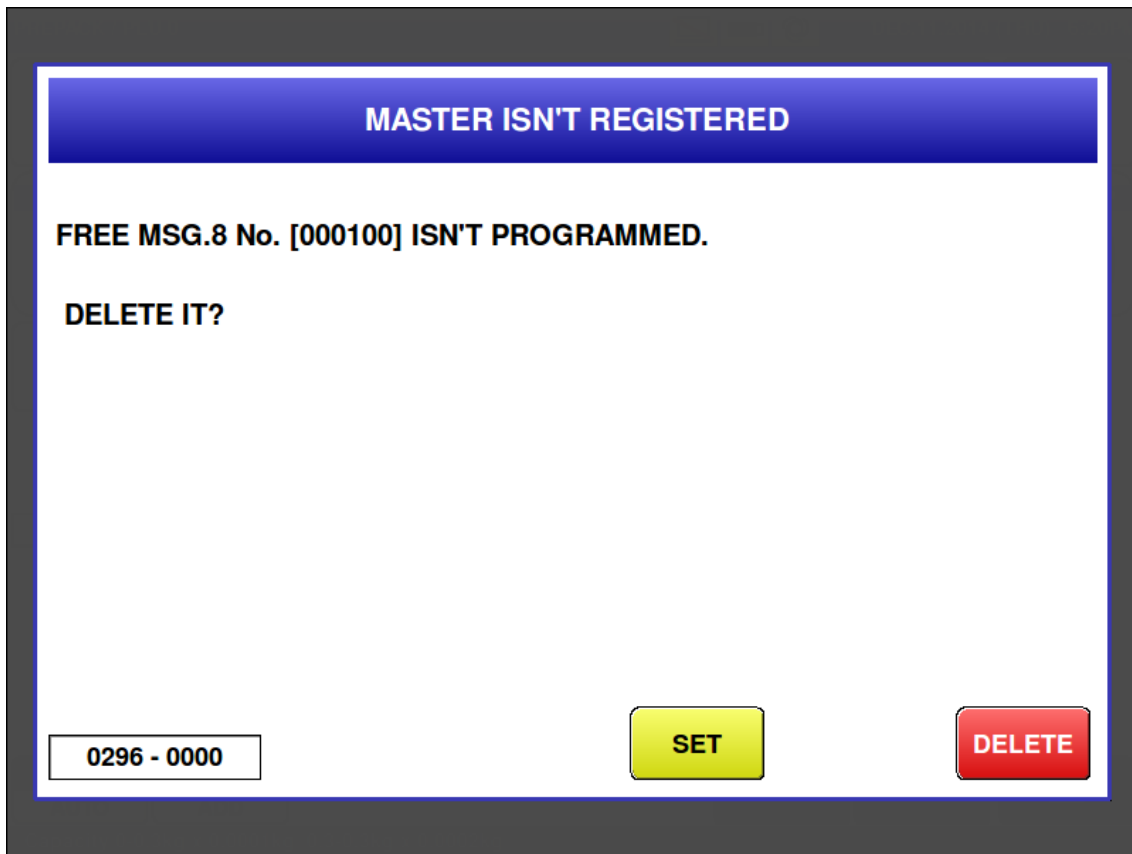

Error content	The called Free Message 8 is not found.
Detail	The message does not exist in the machine's memory.
Solution	[DELETE] button => Delete the PLU's link with the Free Message 8. [SET] button => Cancel error.
Action by user	Recheck the Free Message 8 message number. Program the Free Message 8 message.
Action by service representative	Confirm the master.
Related part	Main board
Remarks	The error for a missing message linked to a PLU can be disabled in the Setup menu > Error Process > Call tab.

■ Free 9 master is not registered (0297)

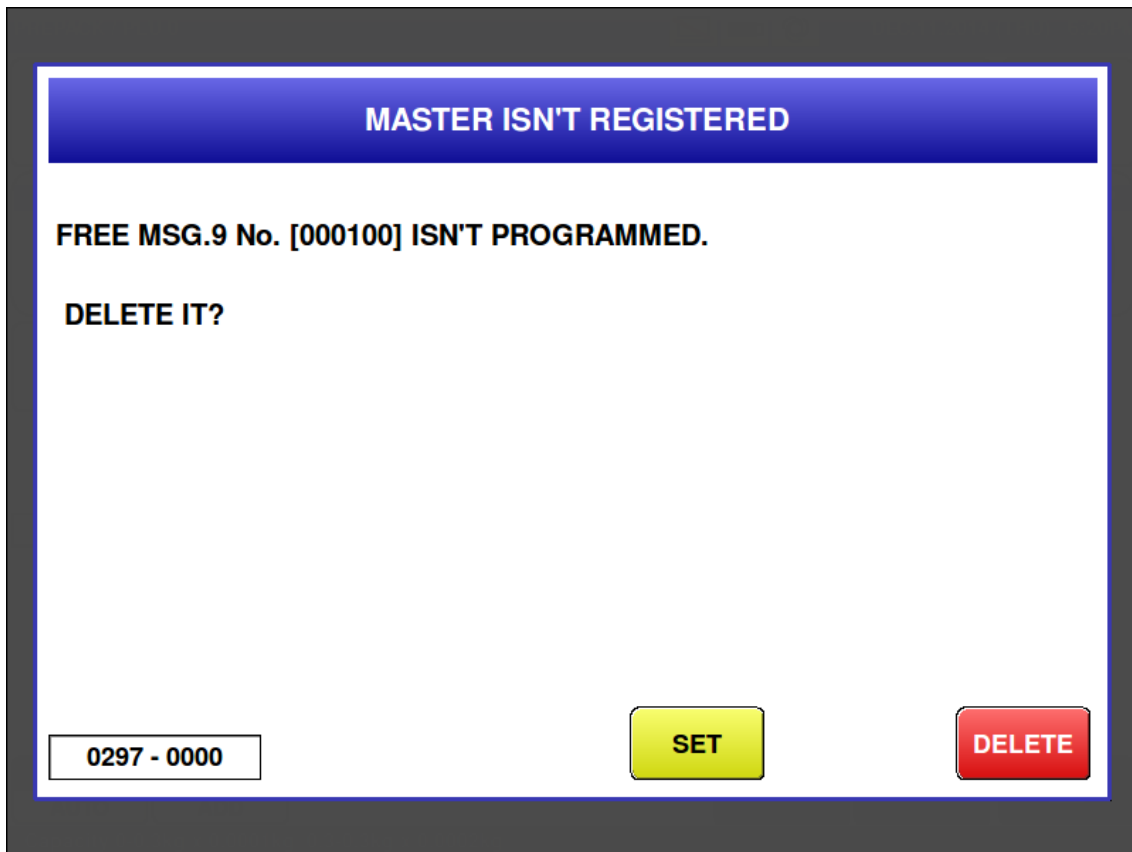

Error content	The called Free Message 9 is not found.
Detail	The message does not exist in the machine's memory.
Solution	[DELETE] button => Delete the PLU's link with the Free Message 9. [SET] button => Cancel error.
Action by user	Recheck the Free Message 9 message number. Program the Free Message 9 message.
Action by service representative	Confirm the master.
Related part	Main board
Remarks	The error for a missing message linked to a PLU can be disabled in the Setup menu > Error Process > Call tab.

■ Free 10 master is not registered (0298)

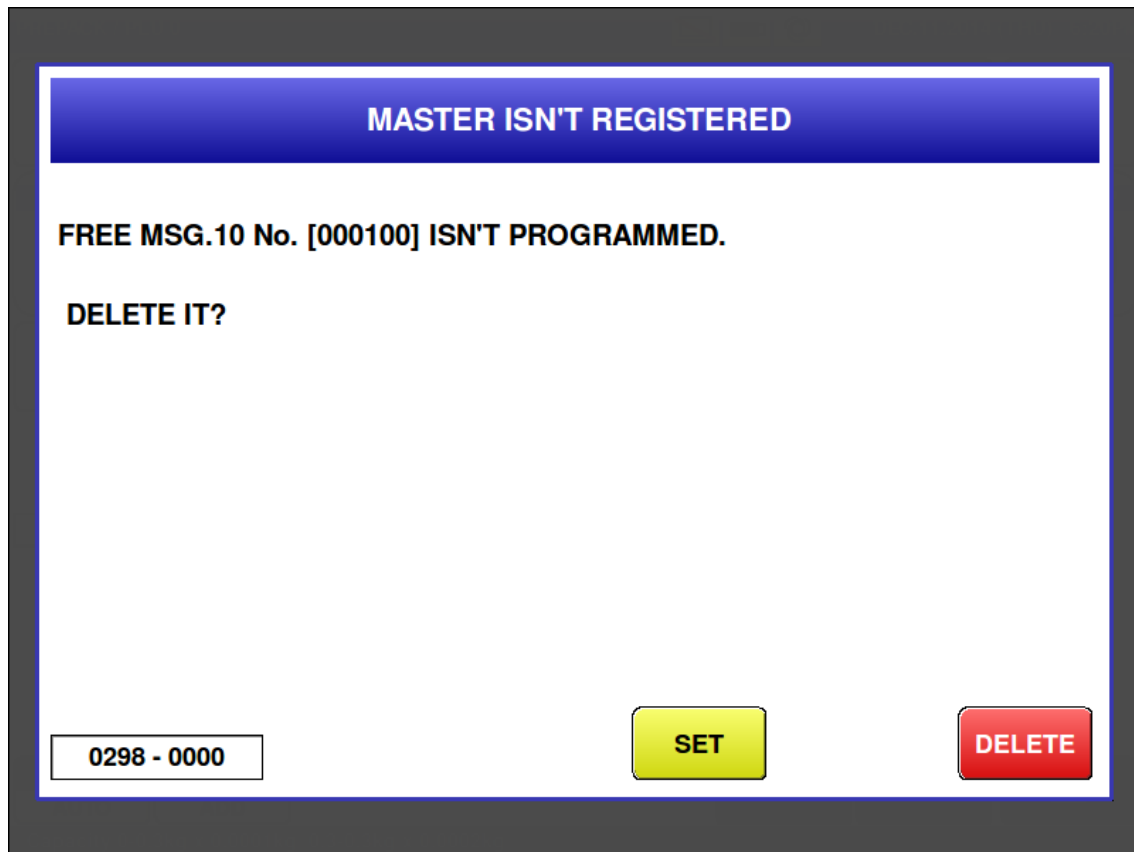

Error content	The called Free Message 10 is not found.
Detail	The message does not exist in the machine's memory.
Solution	[DELETE] button => Delete the PLU's link with the Free Message 10. [SET] button => Cancel error.
Action by user	Recheck the Free Message 10 message number. Program the Free Message 10 message.
Action by service representative	Confirm the master.
Related part	Main board
Remarks	The error for a missing message linked to a PLU can be disabled in the Setup menu > Error Process > Call tab.

6.2.3 Precheck-related Error (No. 300s)

- Label is remaining (0312)



Error content	Label is remaining
Detail	A label remains on the peel bar preventing the next label from printing.
Solution	Remove label, [OK] button
Action by user	Remove the label of the printer.
Action by service representative	Confirm the peel sensor operation of the printer on which an error occurred.
Related part	Main board, P-1100, p/n 158280 Photo interruptor, peel sensor, reflective, p/n 175000
Remarks	

■ Printer thermal head is up (0313)

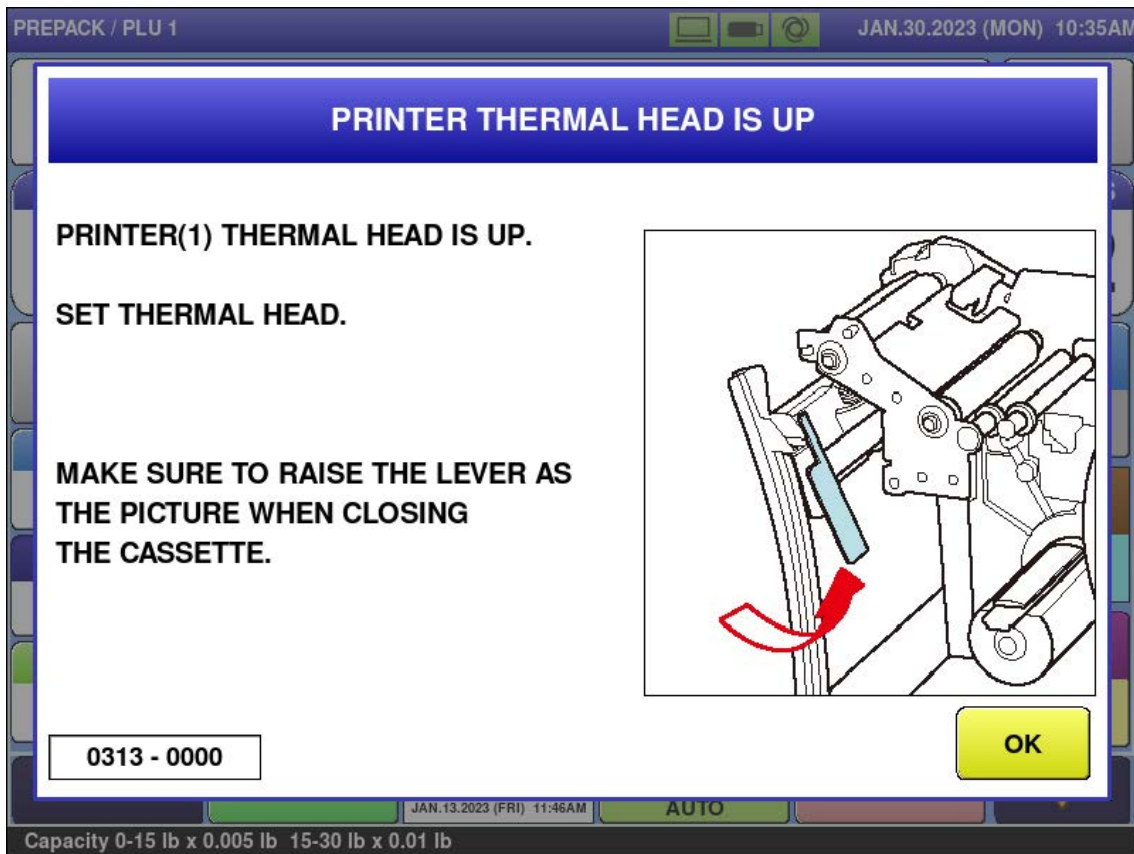

Error content	Printer thermal head is up.
Detail	The label cassette drawer is not closed causing the printer thermal head to be raised.
Solution	Close the label cassette drawer securely.
Action by user	Close the label cassette drawer securely.
Action by service representative	Confirm the thermal head sensor.
Related part	Main board, P-1100, p/n 158280 Sensor assy, cassette closed, p/n 174983
Remarks	Confirm the lever shown in the diagram is raised to the "up" position.

■ Mark down price is more than original price (0316)

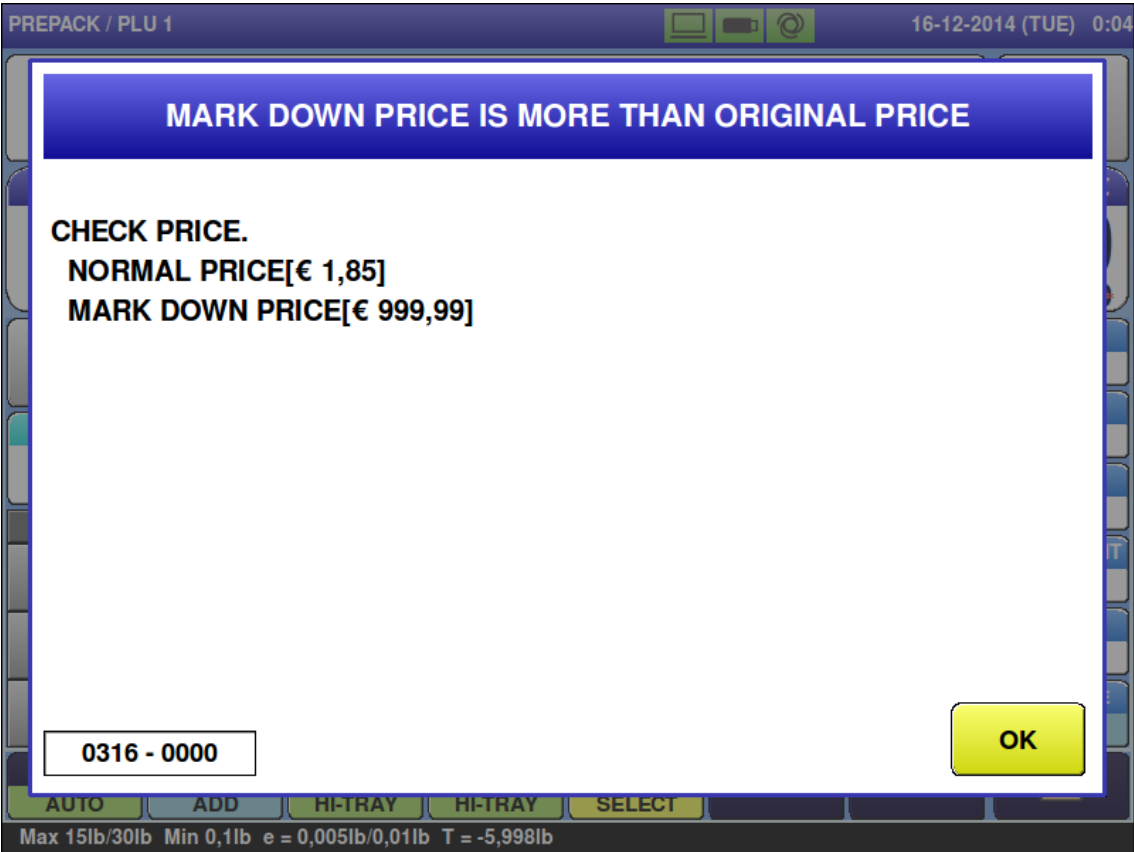

Error content	Mark down price is more than original price
Detail	
Solution	[OK] button
Action by user	Change the mark down price. * Set the mark down price lower than the original price.
Action by service representative	Change the mark down price. Confirm the product master.
Related part	
Remarks	Original price and markdown price are displayed.

■ Mark down unit price is more than original price (0318)

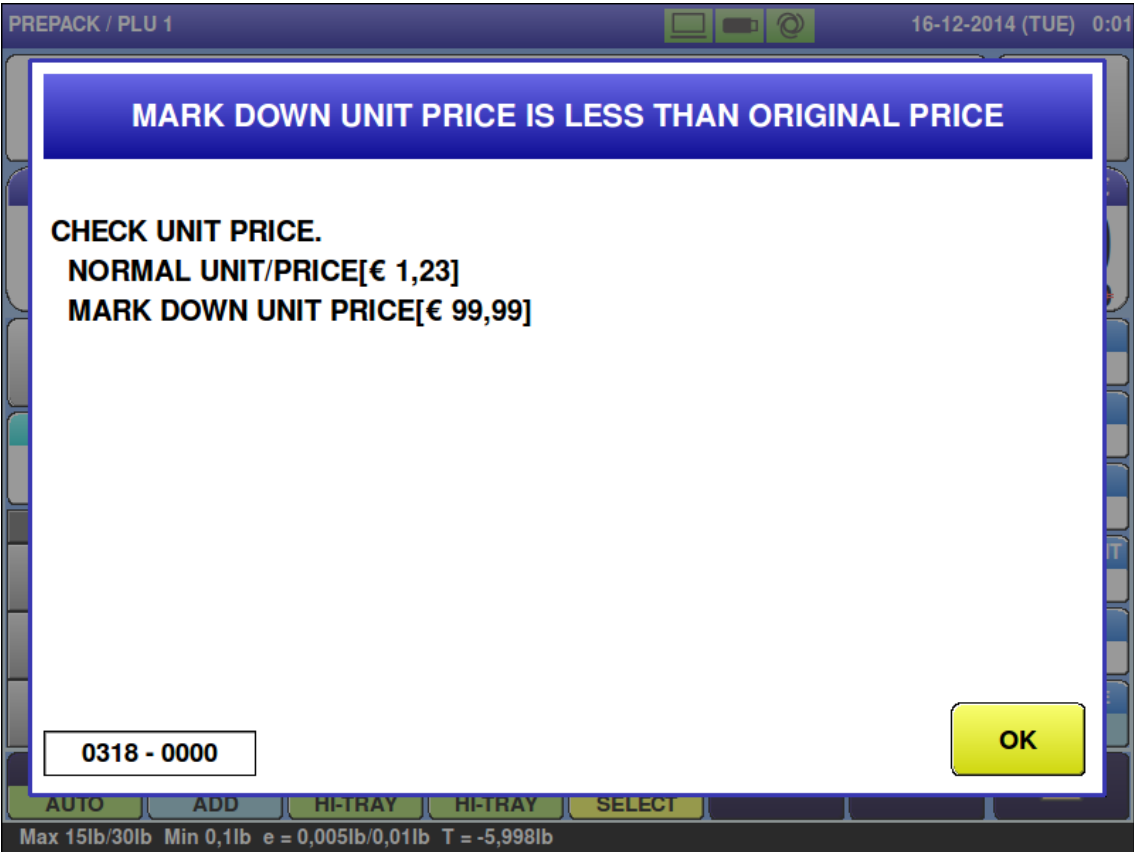

Error content	Mark down unit price is less than original price.
Detail	
Solution	[OK] button
Action by user	Change the mark down price. * Set the mark down price lower than the original price.
Action by service representative	Change the mark down price. Confirm the product master.
Related part	
Remarks	Original price and markdown unit price are displayed.

■ Production for target is completed (0319)

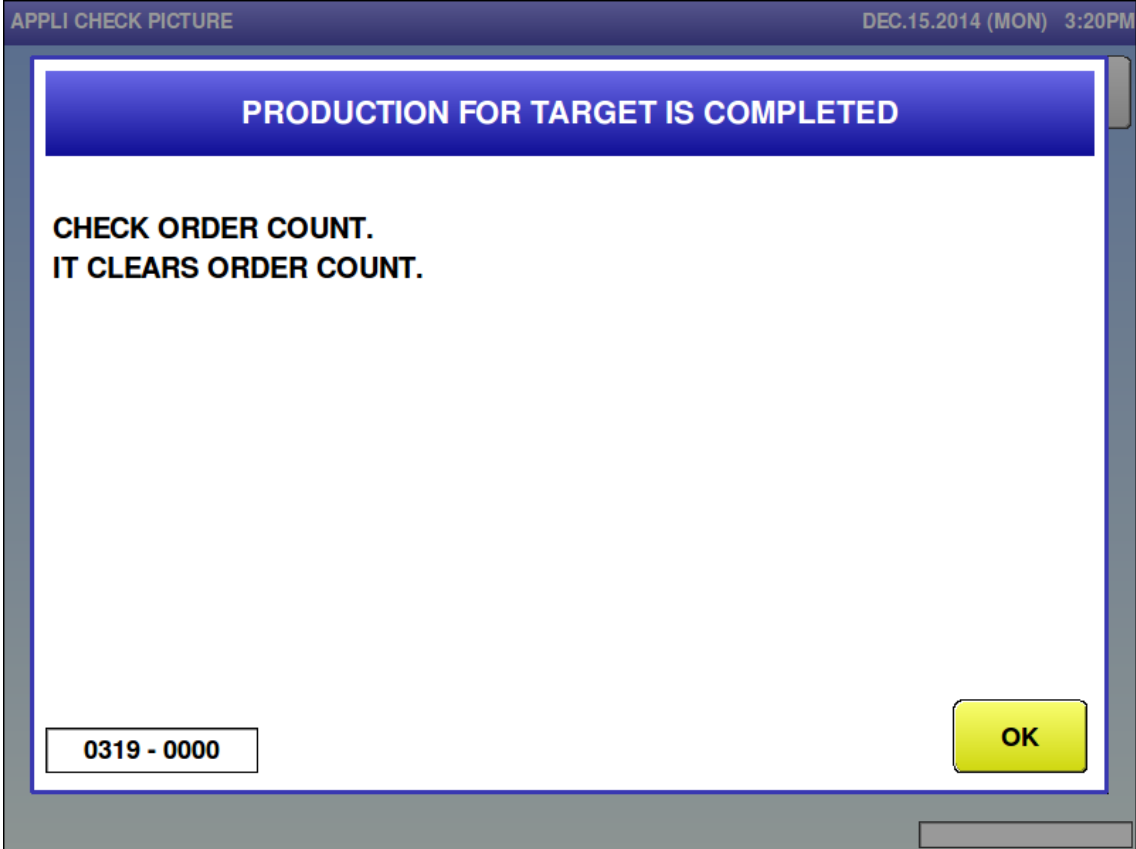

Error content	Production exceeding order count is attempted.
Detail	
Solution	[OK] button
Action by user	Press the [OK] button. Continue production after releasing the error.
Action by service representative	Press the [OK] button.
Related part	
Remarks	Clears order count.

■ Price is not programmed (0321)



Error content	Price is not programmed.
Detail	
Solution	[OK] button
Action by user	Enter the price. Confirm the product master.
Action by service representative	Enter the price. Confirm the product master.
Related part	
Remarks	Does not occur when [Do not display] is selected for 0 price error. Setup menu > Error Process > Display Error: Zero (\$0) Price.

■ Weight is out of range (0325—0000)

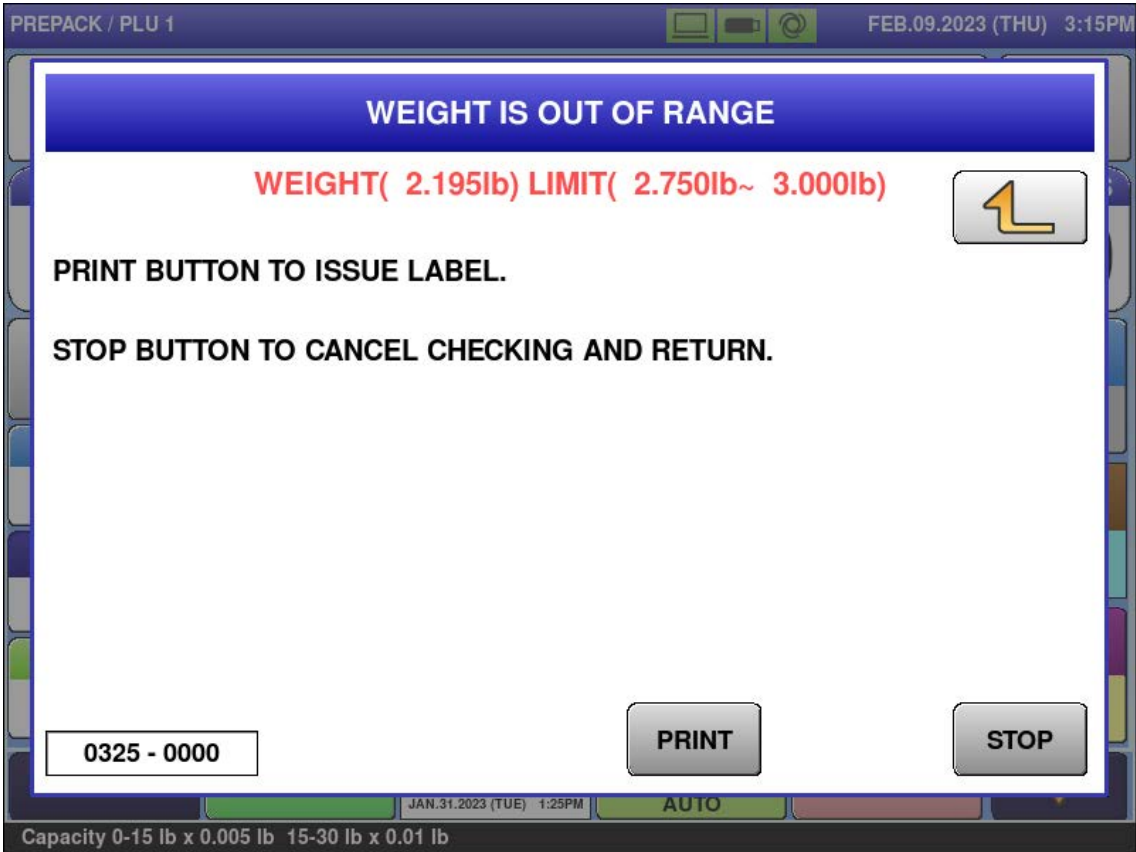

Error content	Weight is out of range.
Detail	Separated by sub-error No. 0000: weight out of range error
Solution	* When there is error because Weight is out of range [PRINT] button: no error [STOP] button: will not check weight until next product is called. Numeric key: close the error screen
Action by user	Increase the weight of the product. Confirm [Upper Limit Weight] and [Lower Limit Weight] of the product master.
Action by service representative	Confirm the product master. Confirm the host product master when linked with the host system.
Related part	
Remarks	Does not check product limits when [No] is selected for product weight measurement in system data settings. Setup menu > Operation Settings > Weighed Items' Weight Ranges Check or Fix Price Items' Weight Ranges Check.

■ Completed production for order count (0336)

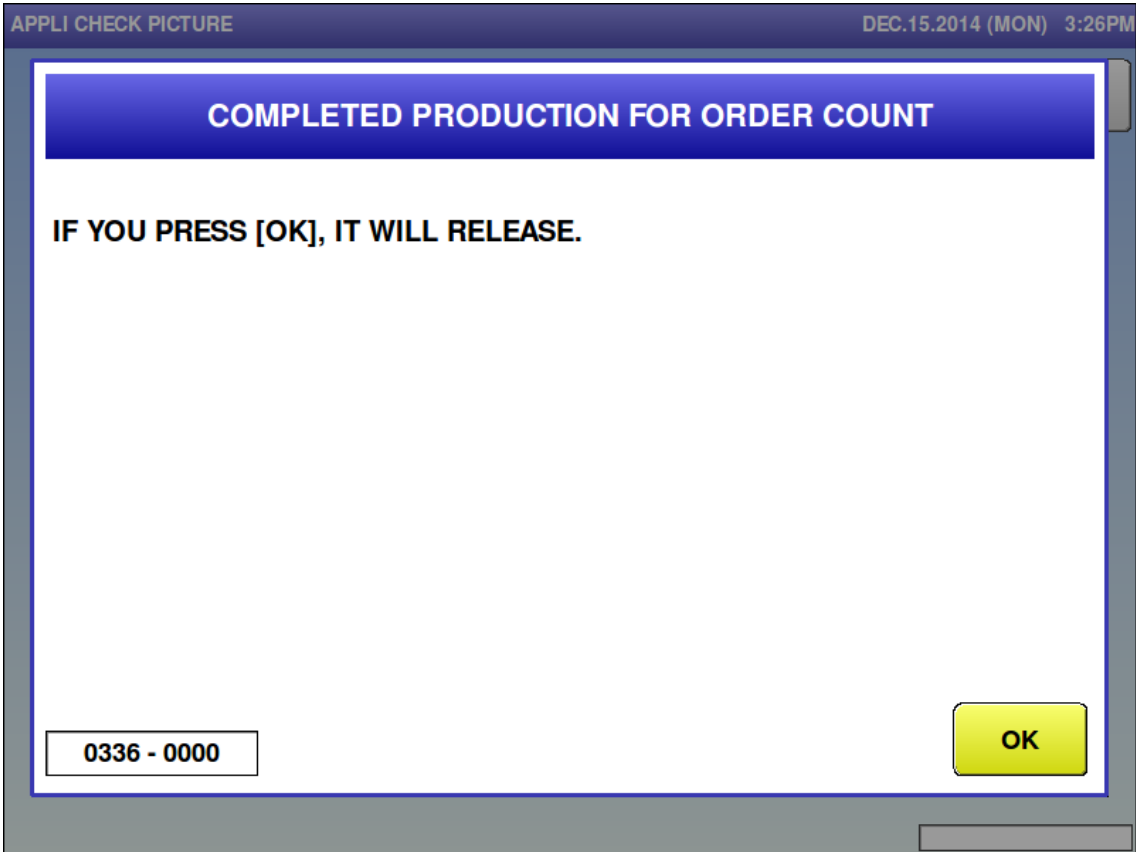

Error content	Order count has been completed.
Detail	
Solution	[OK] button
Action by user	Press the [OK] button.
Action by service representative	Press the [OK] button.
Related part	
Remarks	Displayed when [End message] is selected in system data settings in system mode.

■ Lower value is less than fixed weight (0339)

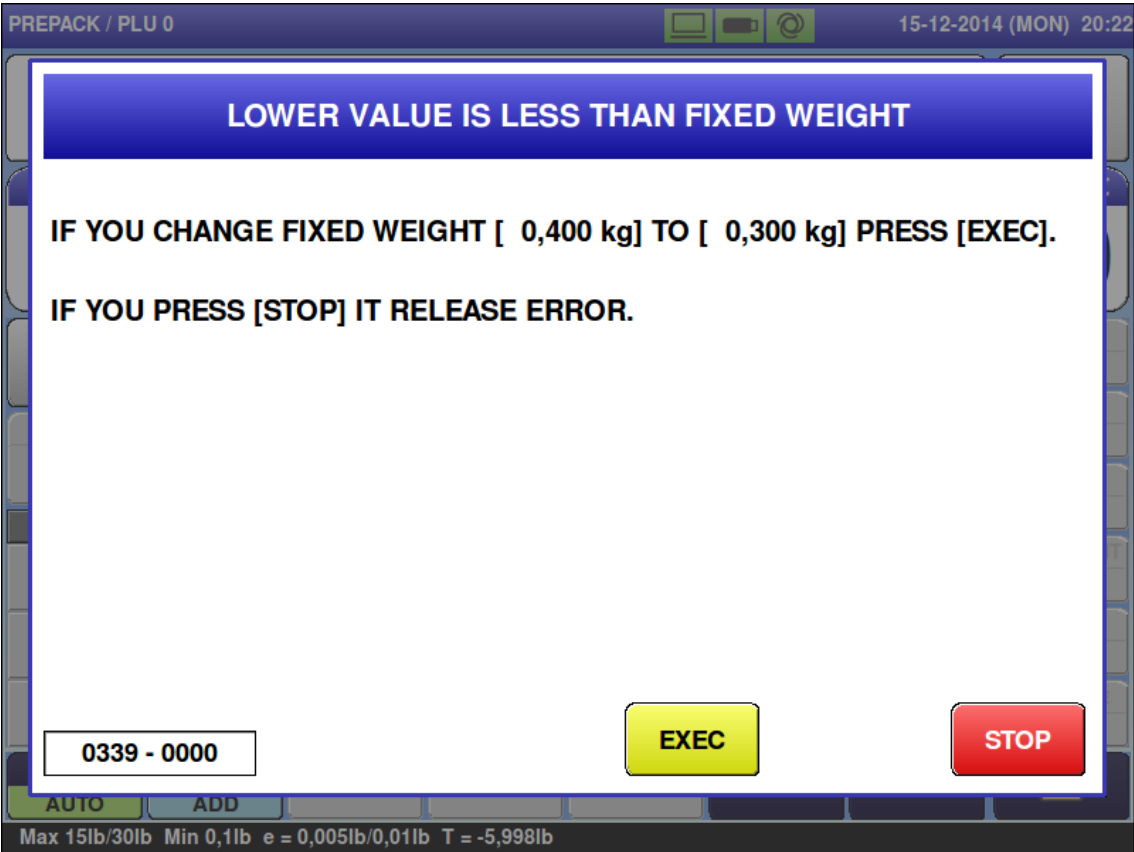

Error content	Lower value is less than fixed weight.
Detail	Attempted to enter a minimum value lighter than the fixed weight in fixed weight mode.
Solution	[EXEC] button => Set fixed weight to the minimum value. [STOP] button => Release error.
Action by user	Confirm [Fixed weight] and [Lower limit weight] of the product master.
Action by service representative	Confirm the product master. Confirm the host product master when linked with the host system.
Related part	
Remarks	The minimum value will remain the same if the error is released.

■ POS code is not programmed (0342)

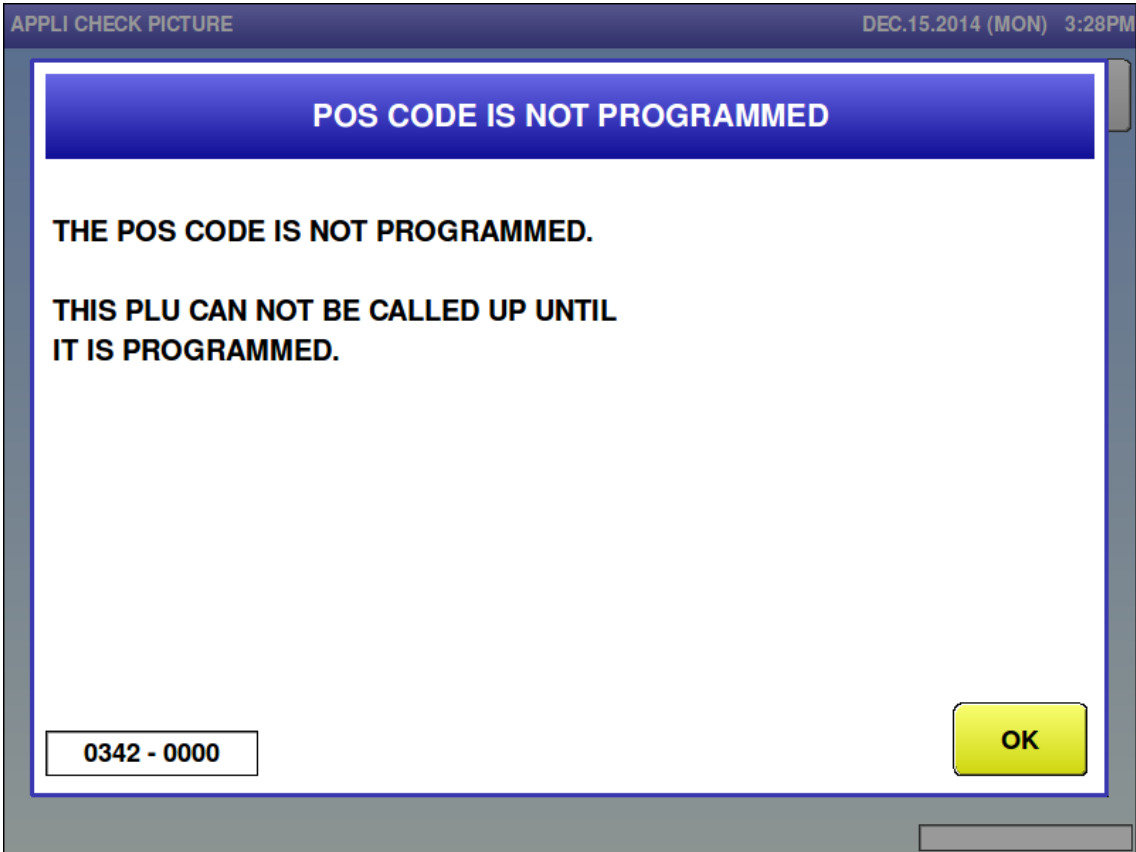

Error content	POS code is not programmed.
Detail	
Solution	[OK] button
Action by user	On the [Register: Product] screen, enter "POS code" of the target product.
Action by service representative	Confirm the product master. Confirm the host product master when linked with the host system.
Related part	
Remarks	* Occurs when [POS code unregistered error] is set. *Labels cannot be issued.

■ Tray no. is not programmed (0350)

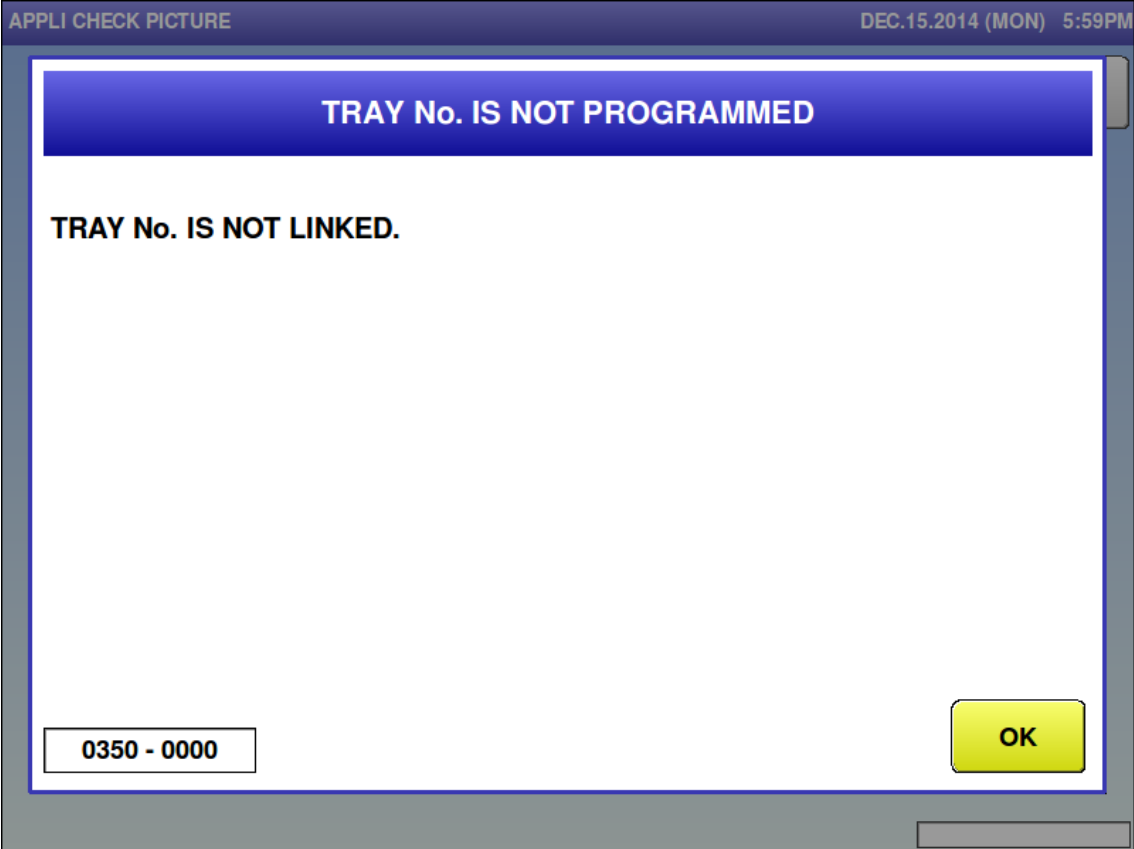

Error content	Tray no. is not programmed in product.
Detail	
Solution	[OK] button
Action by user	Enter the tray number to use.
Action by service representative	Confirm the product master. Confirm the tray master. Confirm the host product master when linked with the host system.
Related part	
Remarks	

■ Label is remaining (0351)

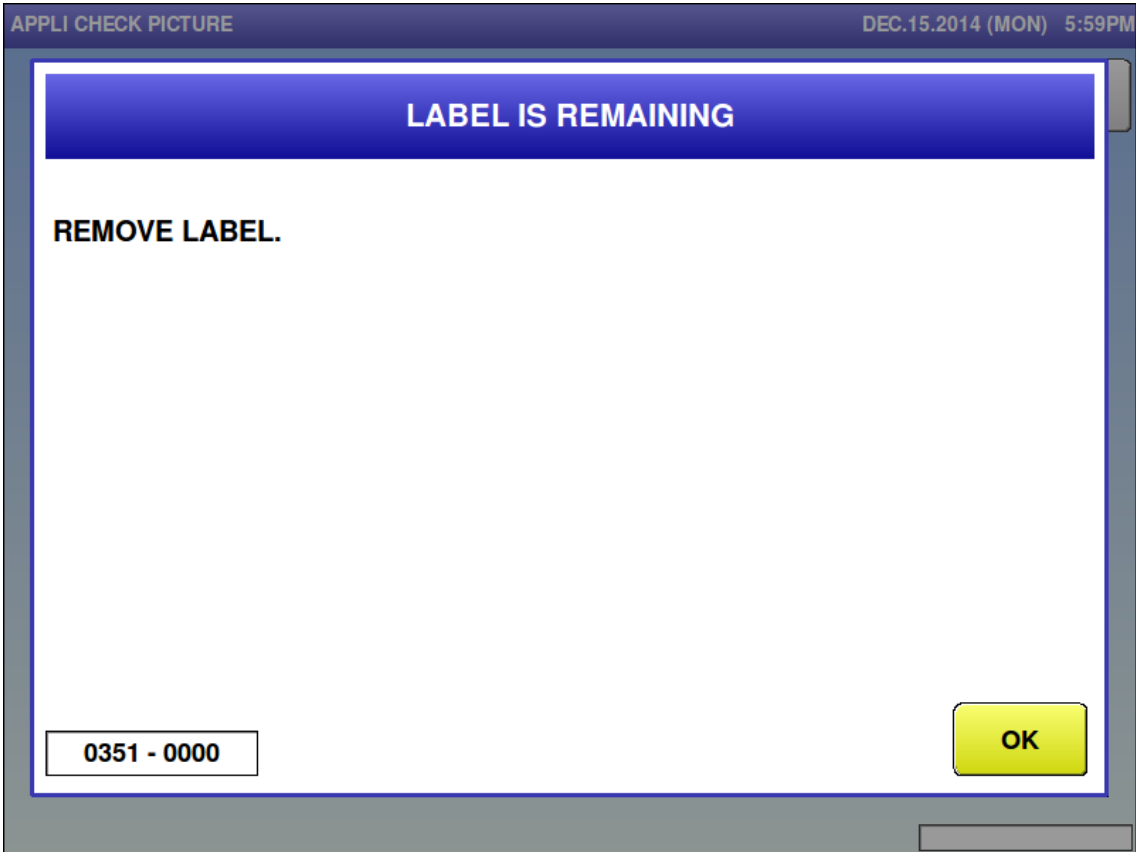

Error content	Label is remaining
Detail	
Solution	Remove label, [OK] button
Action by user	Press the [OK] button to finish production.
Action by service representative	Press the [OK] button to finish production. Confirm that there is no actual result remaining error.
Related part	Main board, P-1100, p/n 158280 Photo interruptor, peel sensor, reflective, p/n 175000
Remarks	Remove the label from the printer. Check and clean the peel sensors as needed.

■ Tray no. is not programmed (0355)

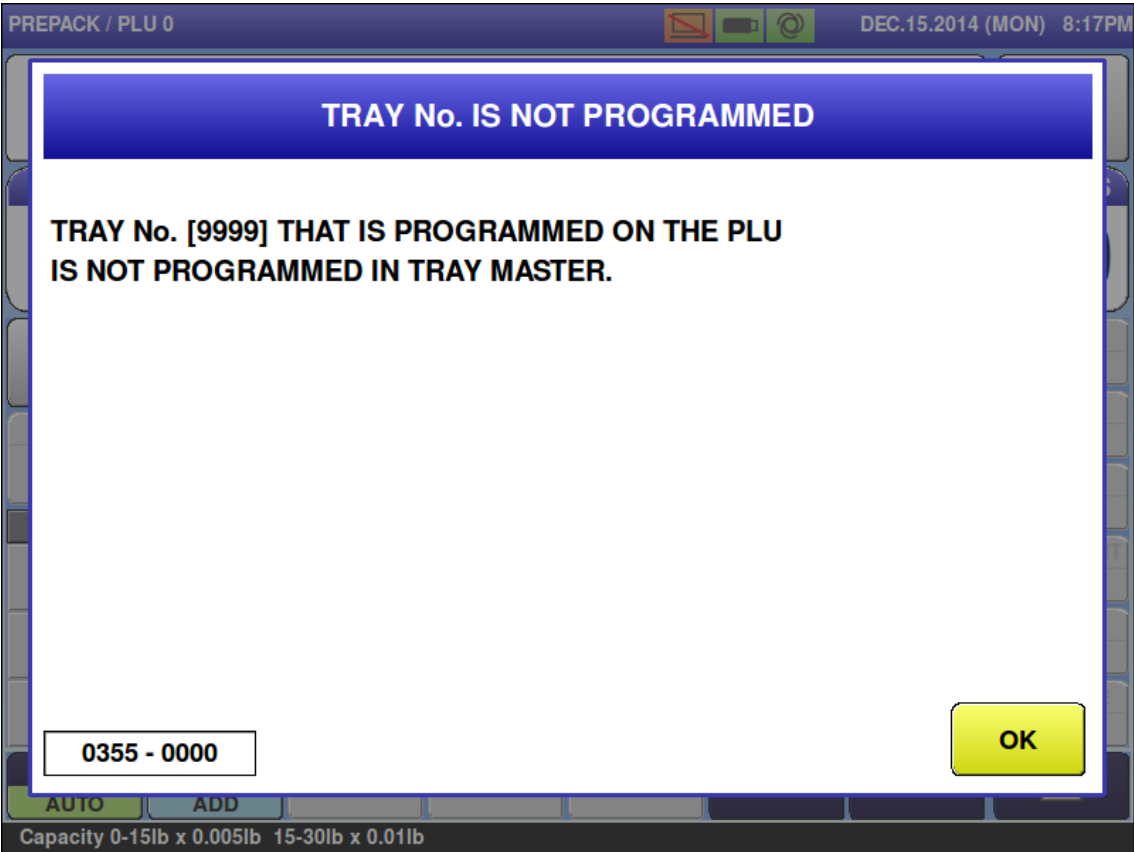

Error content	The tray number set for the product is not registered in the tray master.
Detail	
Solution	[OK] button
Action by user	Register the tray number to be used for tray master. Confirm the product master.
Action by service representative	Confirm the tray master and product master. Confirm the host product master and tray master when linked with the host system.
Related part	
Remarks	Tray no. that is set is displayed.

■ No USB memory (0396)

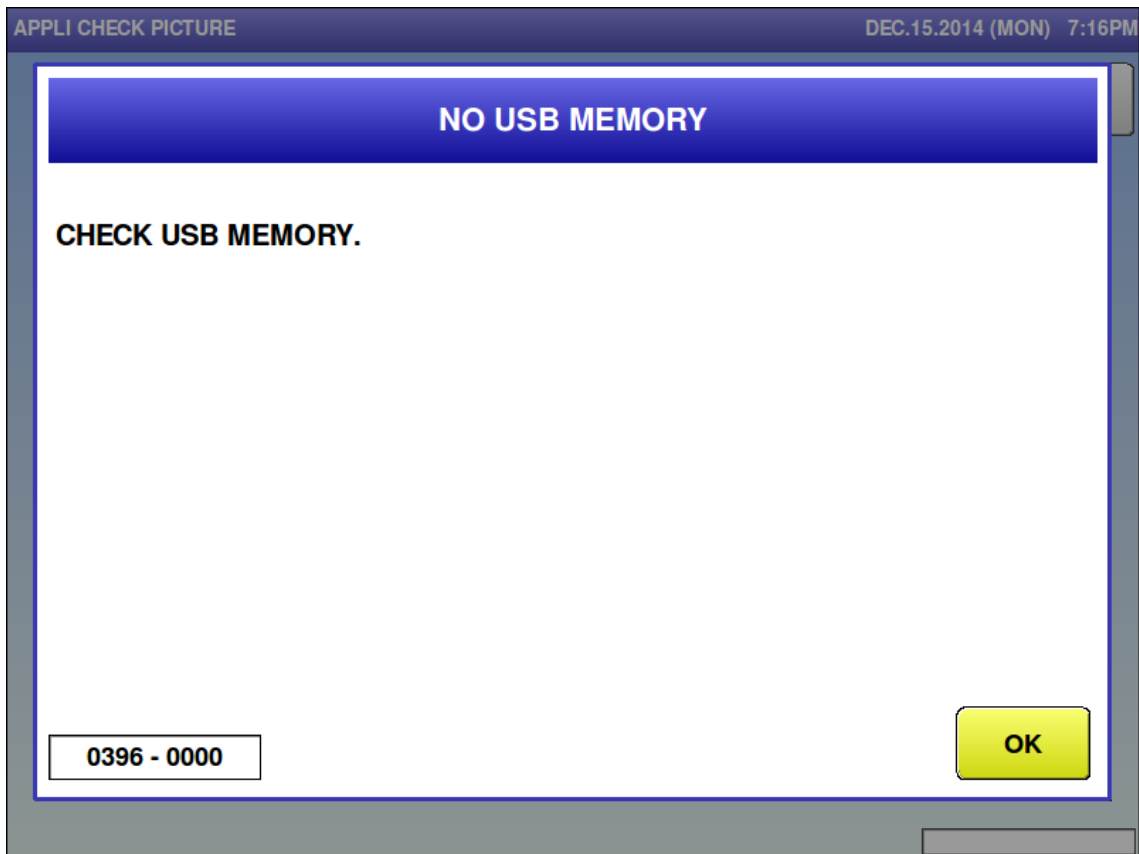

Error content	USB memory is not inserted.
Detail	
Solution	[OK] button
Action by user	Set the USB memory to the machine.
Action by service representative	Set the USB memory to the machine. Confirm the USB memory (recommended by Ishida) inserted.
Related part	Main board, P-1100, p/n 158280
Remarks	

6.2.4 Printer-related Error (No. 700s to 800s)

- Printer 1 has problem (703, 803)

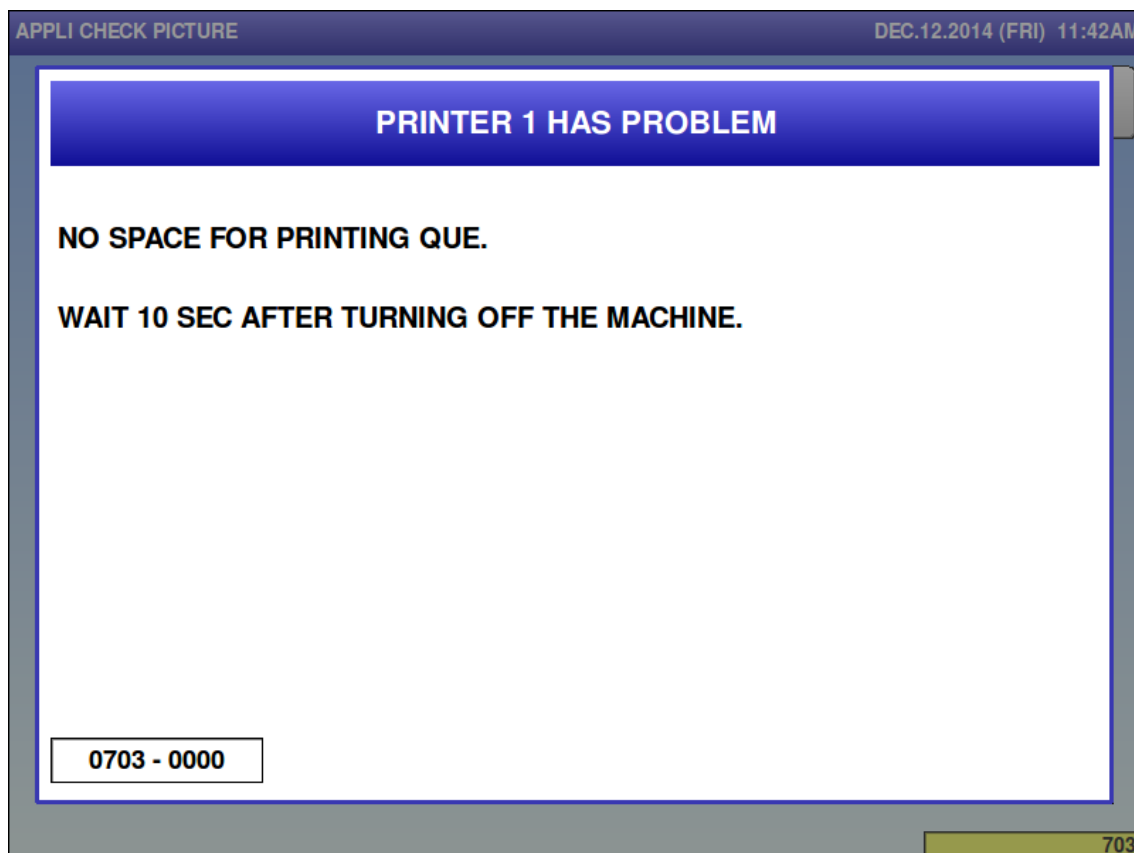

Error content	Printer system error
Detail	The print queue in main program has error.
Solution	Power the scale off, wait wait at least 10 seconds, and power on.
Action by user	Power the scale off, wait wait at least 10 seconds, and power on.
Action by service representative	The sequence has shifted for some reason, so power the scale off, wait wait at least 10 seconds, and power on.
Related part	
Remarks	"Printer No.1" changes depending on error No.

- .Printer 1 has problem (704, 804)

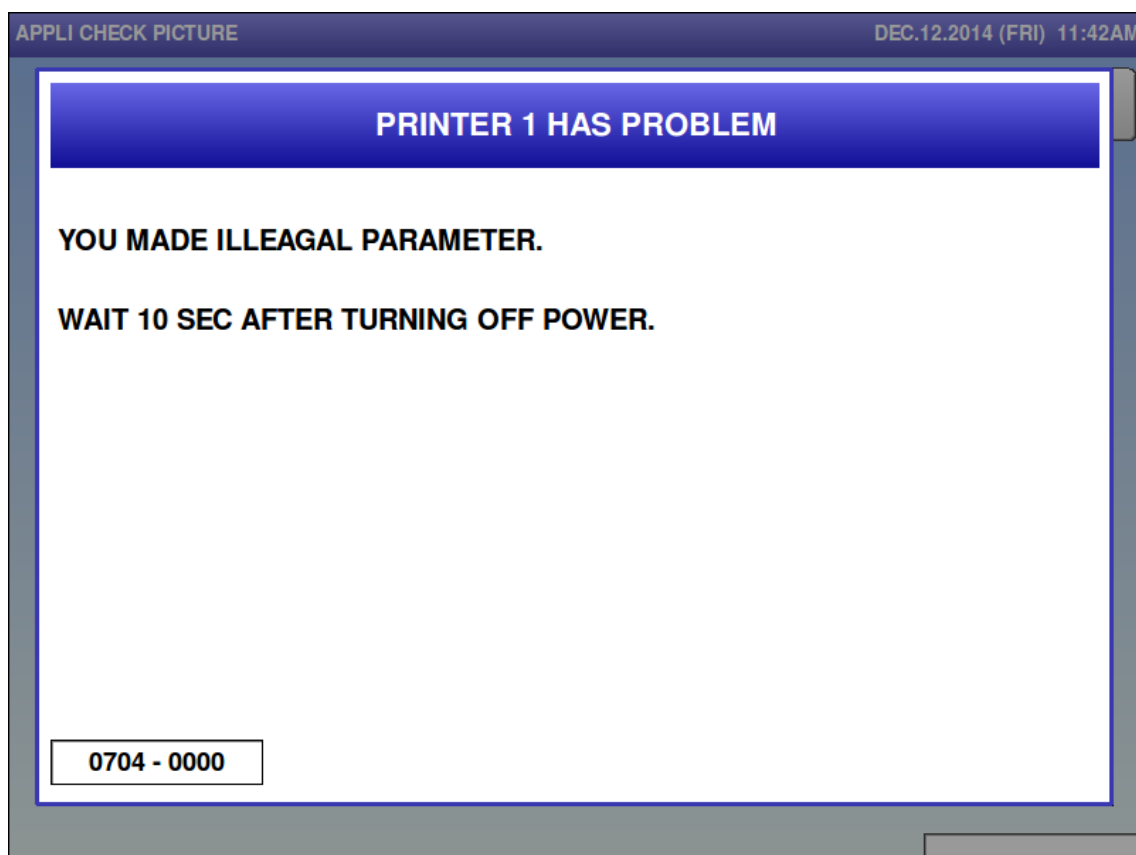

Error content	Printer system error
Detail	Processed an invalid parameter.
Solution	Power the scale off, wait wait at least 10 seconds, and power on.
Action by user	Power the scale off, wait wait at least 10 seconds, and power on.
Action by service representative	Power the scale off, wait wait at least 10 seconds, and power on.
Related part	
Remarks	"Printer No.1" changes depending on error No.

■ Printer1 is not initialized (707, 807)

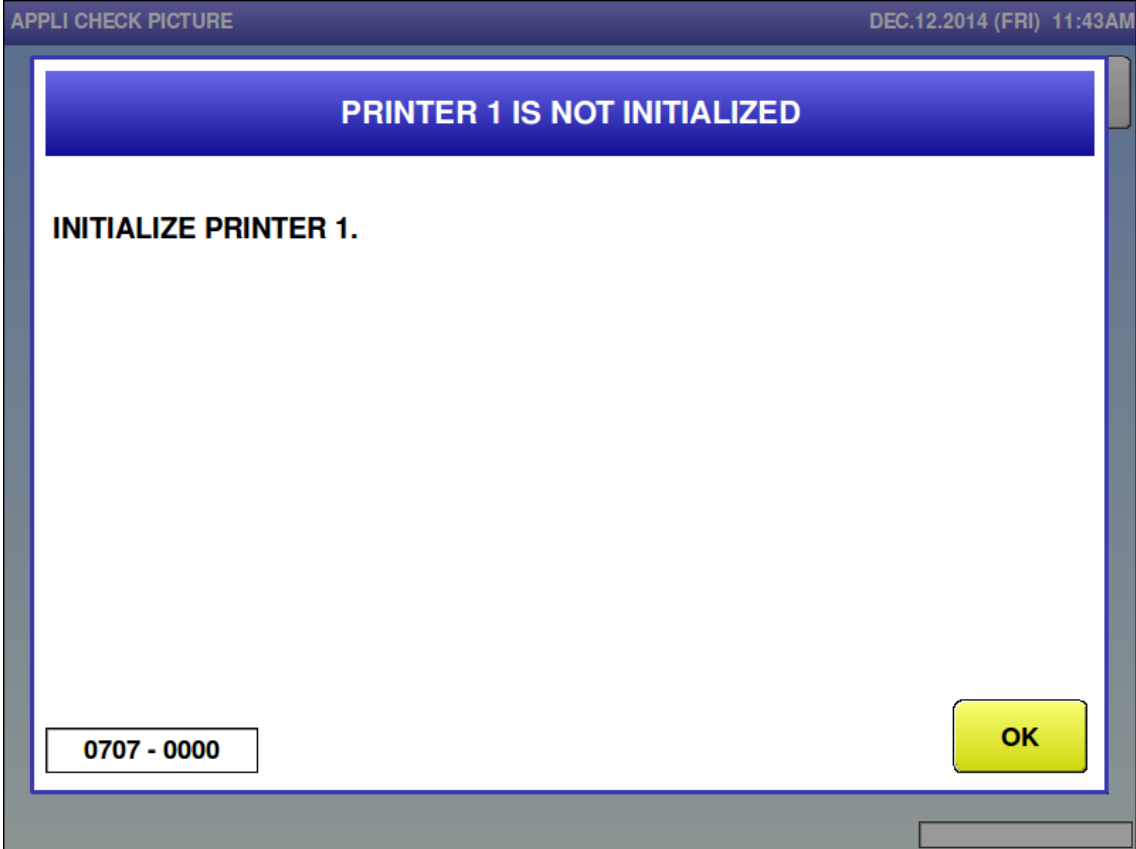

Error content	The printer is not initialized.
Detail	Incomplete printer initialization.
Solution	Press the [OK] button.
Action by user	Press the [OK] button.
Action by service representative	Note all printer settings, initialize the printer, then reenter the settings. (Adjust menu > Printer > Head tab > PRINTER INIT. and HEAD INIT.)
Related part	
Remarks	"Printer No.1" changes depending on error No.

■ No label for printer1 (0710, 0810)

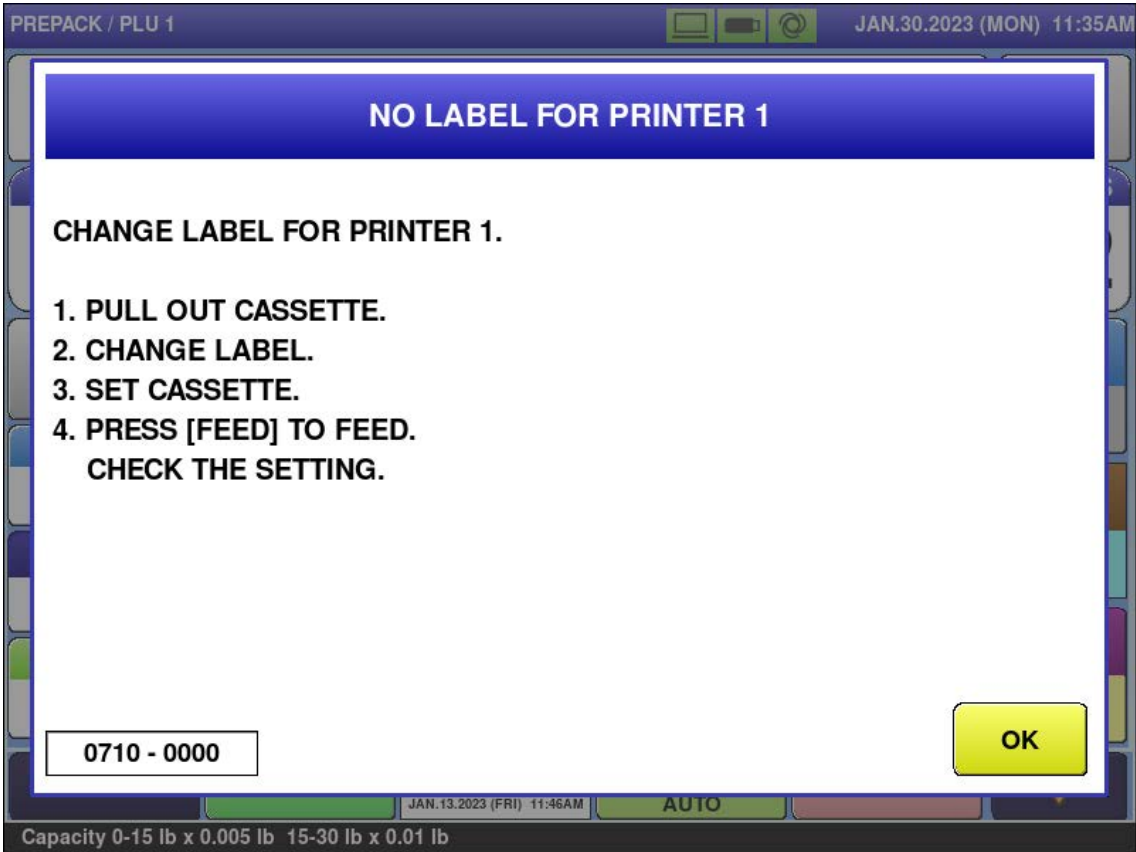

Error content	Printer label finished.
Detail	Message indicates that the labels ran out.
Solution	Press the [OK] button after replacing the label roll, then press the [FEED] button to align the labels as needed.
Action by user	Press the [OK] button after installing a new roll of labels, then press the [FEED] button to align the labels as needed.
Action by service representative	- Clean the label gap sensor. - Calibrate the label gap sensor: Adjust menu > Printer > Label Feed tab > Detail
Related part	Label gap sensor assy, p/n 175007
Remarks	"Printer No.1" changes depending on error No.

■ Label size error for printer1 (0711, 0811)

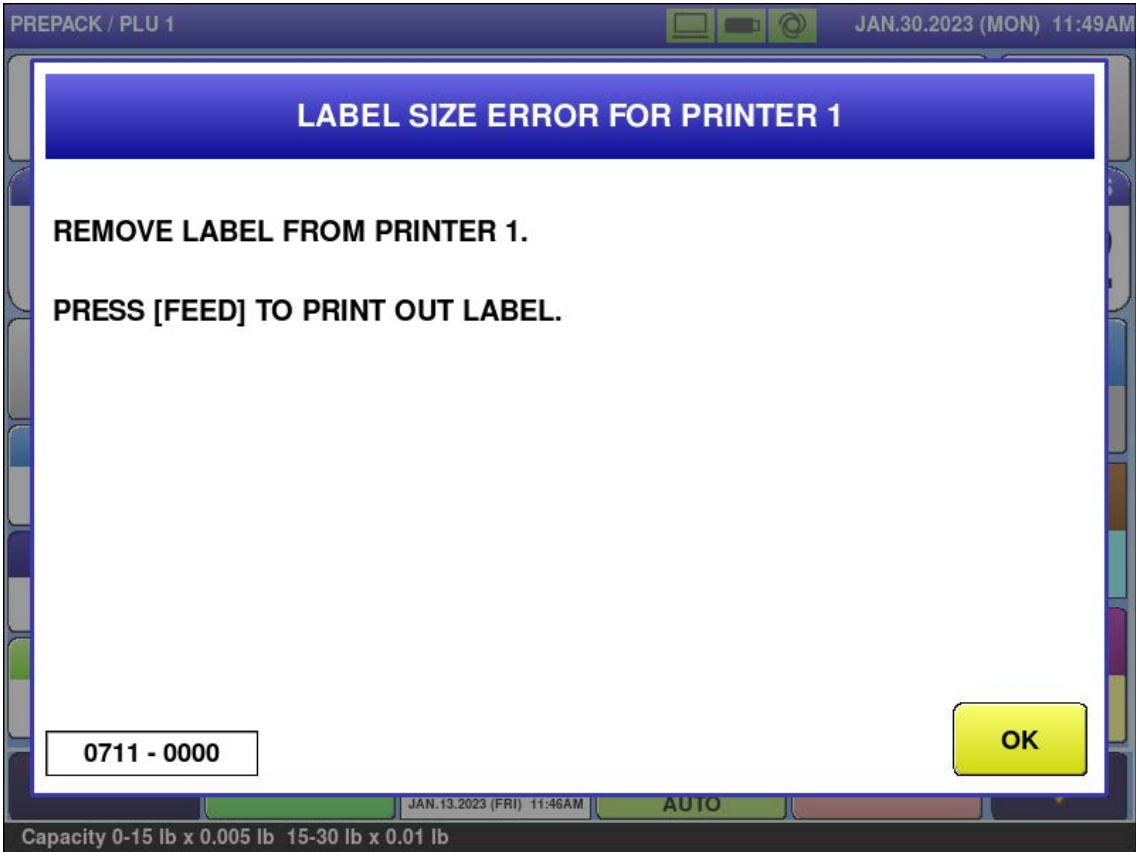

Error content	Label size error for printer1
Detail	Error indicates that the label size detected by the label gap sensor is different from actual label size.
Solution	Press the [OK] button after removing the label by pressing the [FEED] key.
Action by user	Press the [OK] button after removing the label by pressing the [FEED] key.
Action by service representative	<ul style="list-style-type: none"> - Check the label format size. - Clean the label gap sensor. - Calibrate the label gap sensor: Adjust menu > Printer > Label Feed tab. - Check for labels sticking or binding. - Measure the label and verify with the label format length.
Related part	Label gap sensor assy, p/n 175007
Remarks	"Printer No.1" changes depending on error No.

■ Too many characters on format for printer 1 (713, 813)

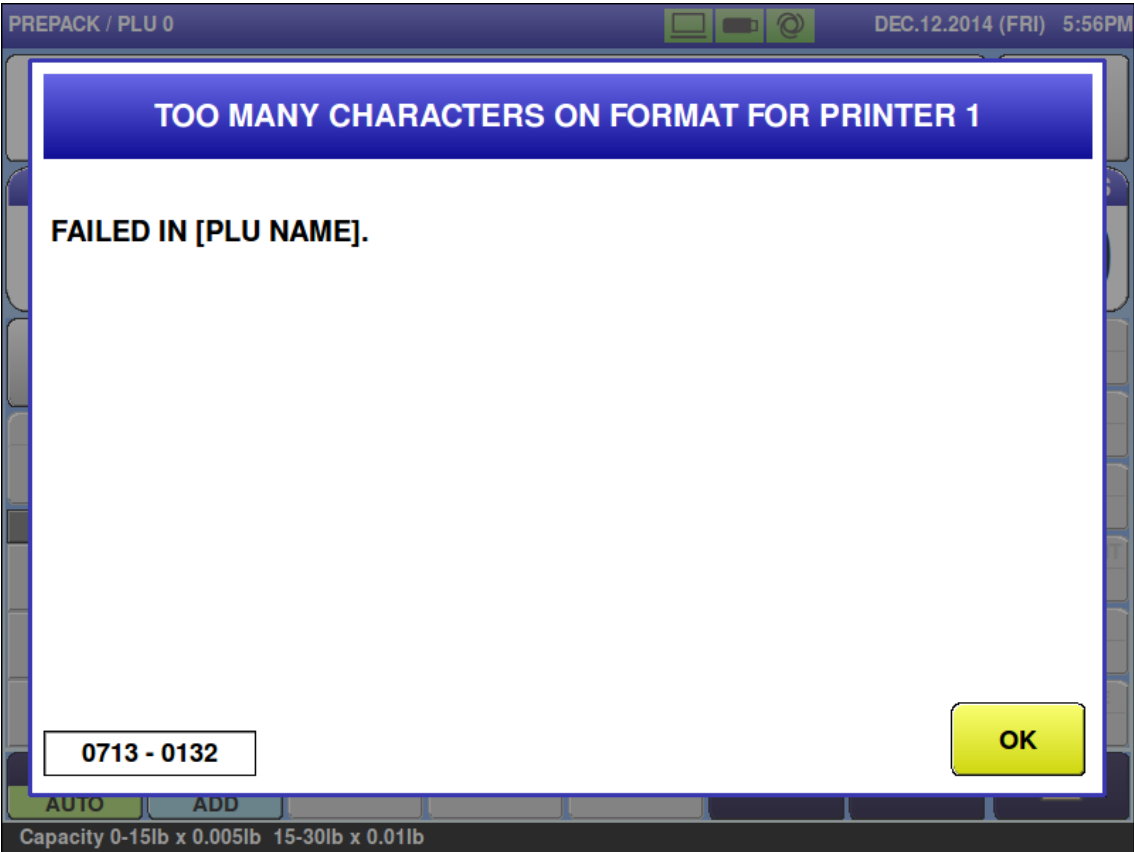

Error content	Too many characters on format for printer1.
Detail	The sub-error No. identifies the label format field that is too small to accommodate all the information associated with the PLU.
Solution	Press the [OK] button
Action by user	Press the [OK] button and adjust the data to fit the available space of the label format field.
Action by service representative	Adjust the identified label format field to accommodate the PLU data.
Related part	
Remarks	<ul style="list-style-type: none"> • “Printer No.1” changes depending on error No. • 0713-0132. This also occurs if there are two or more Product Name fields in the label format. The PLU name does not print -- even if one of the fields is large enough.

- Thermal head is worn out for printer 1 (715-0001, 715-0004, 815-0001, 815-0004)

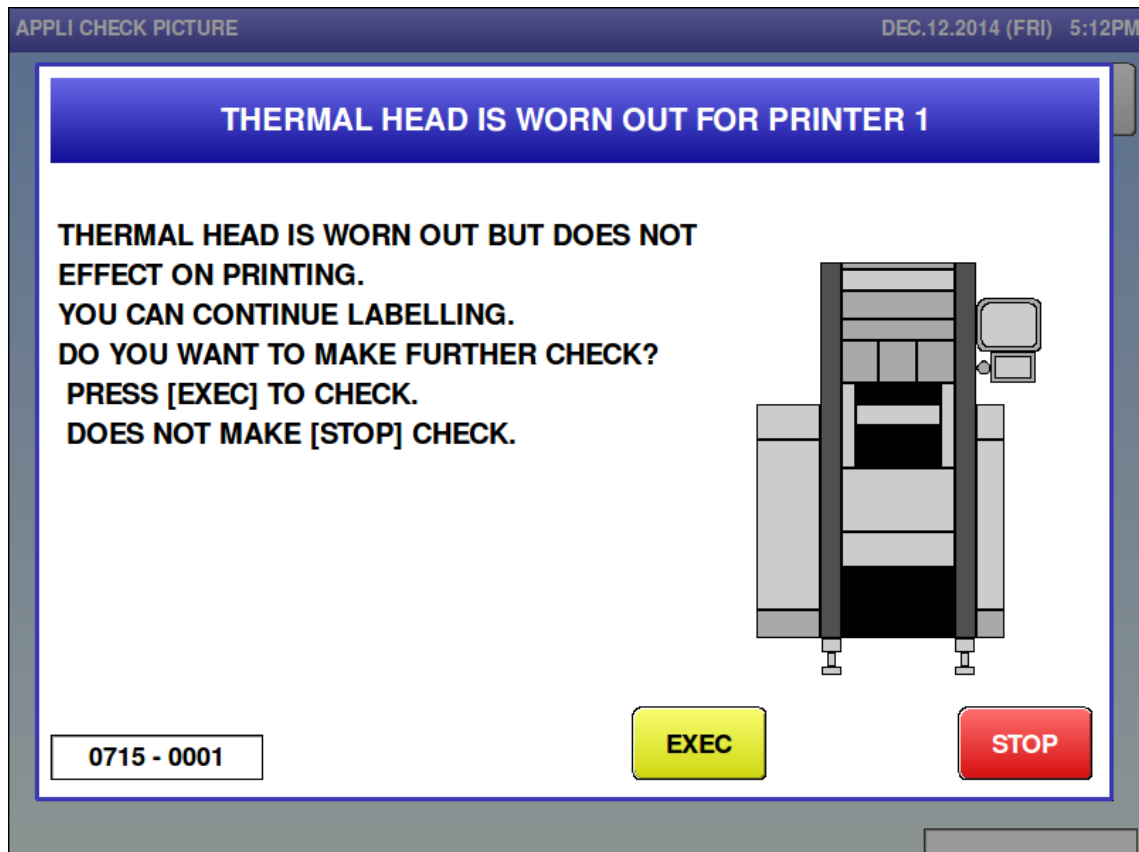

Error content	Thermal head is worn out for printer 1
Detail	The sub-error number indicates where the defective dot is located. 0001, 0004: The portion that as run out has no effect on printing
Solution	Press the [EXEC] button, or the [STOP] button [EXEC] : Head check is performed for the next product as well [STOP] ; Head check is not performed for the next product.
Action by user	0001, 0004: Can be used because it does not affect printing. However, there is a high possibility that other dots will fail due to life expectancy, so contact your dealer.
Action by service representative	0001, 0004: Can be used because it does not affect printing. However, there is a high possibility that other dots will fail due to life expectancy, so replace the thermal head when possible.
Related part	Thermal print head, p/n 171875
Remarks	"Printer No.1" changes depending on error No.

- Thermal head is worn out for printer 1 (715-0002, 815-0002)

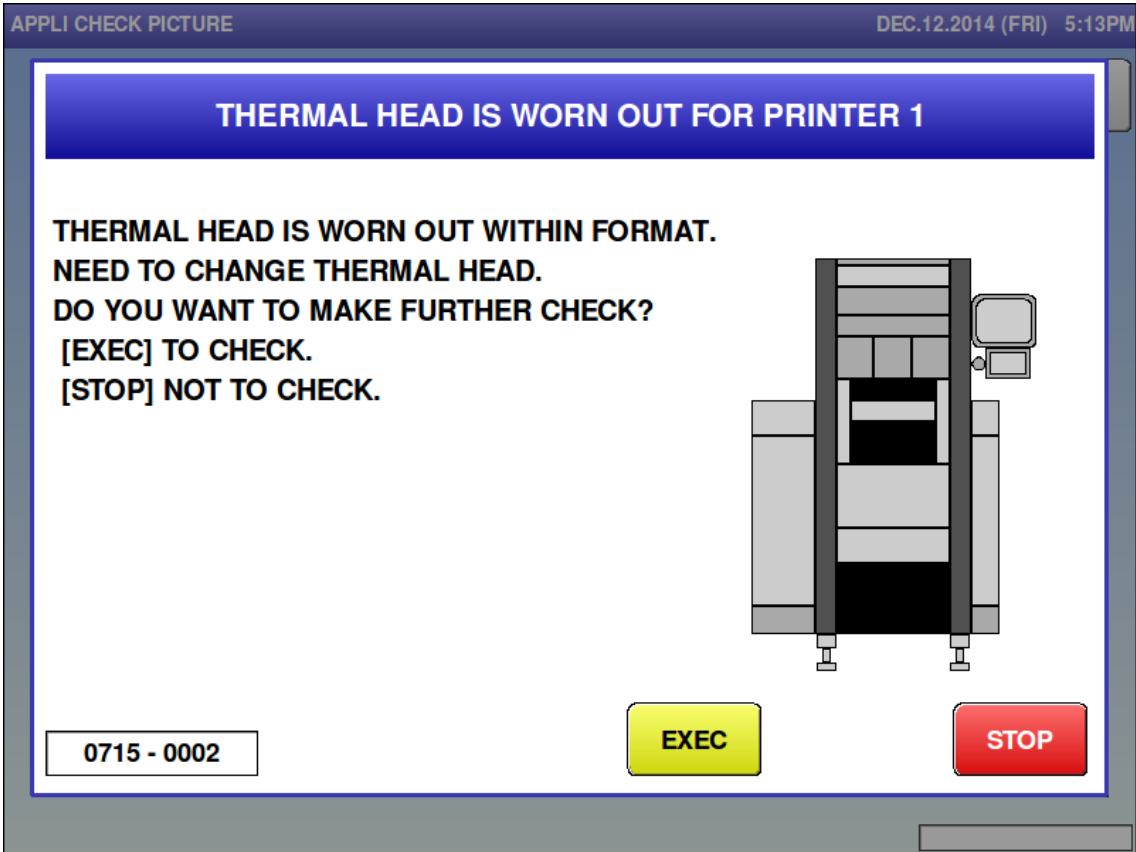

Error content	Thermal head is worn out for printer 1
Detail	The sub-error number indicates where the defective dot is located. 0002: There is print missing on the label.
Solution	Press the [EXEC] button, or the [STOP] button [EXEC] : Head check is performed for the next product as well. [STOP] ; Head check is not performed for the next product
Action by user	0002: There is a defect that will affect printing. It can be used if there is no problem after checking the printed contents of the label. However, there is a high possibility that other parts of the print head will fail due to age and usage. Contact your dealer.
Action by service representative	0002: There is a defect that will affect printing. It can be used if there is no problem after checking the printed contents of the label. However, there is a high possibility that other parts of the print head will fail due to age and usage. Replace the thermal head.
Related part	Thermal print head, p/n 171875
Remarks	"Printer No.1" changes depending on error No.

- Thermal head is worn out for printer 1 (715-0003, 815-0003)

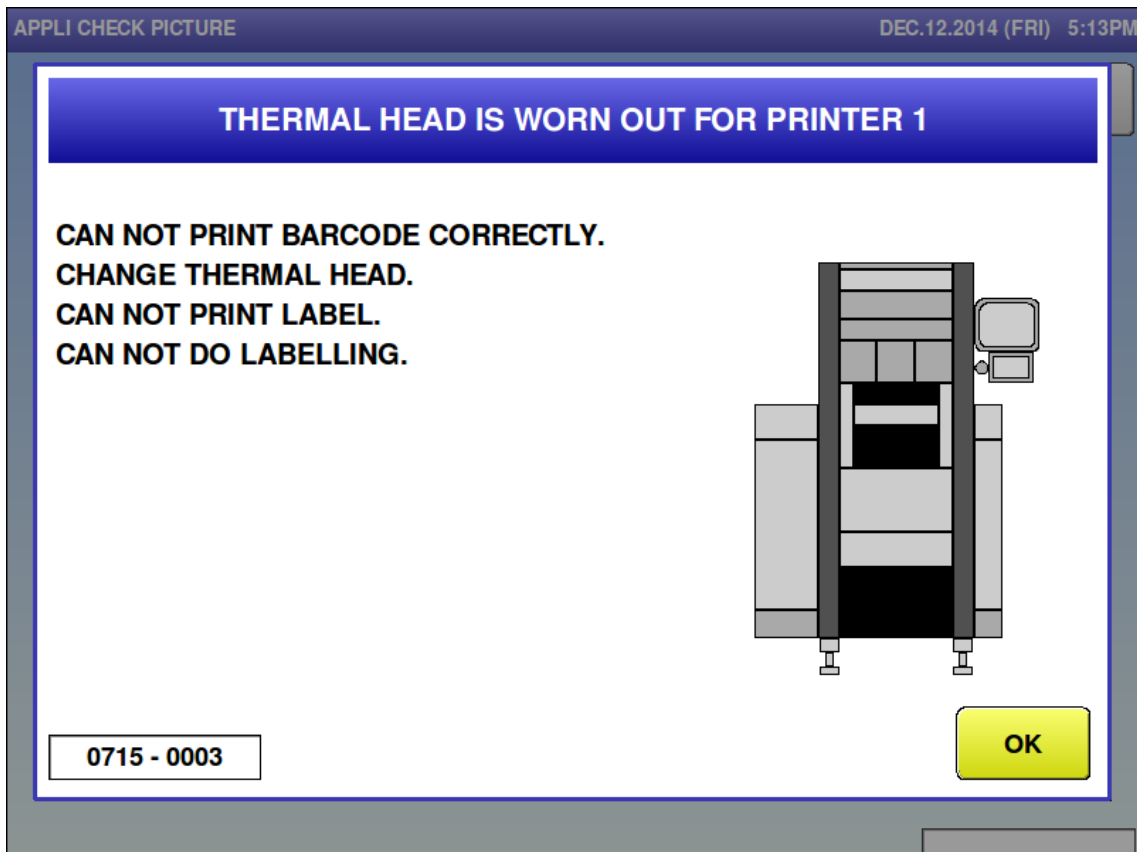

Error content	Thermal head is worn out for printer 1.
Detail	The sub-error number indicates where the defective dot is located. 0003: The barcode cannot be printed properly.
Solution	Press the [OK] button
Action by user	0003: The barcode is incomplete. The barcode cannot be scanned. Contact your dealer.
Action by service representative	0003: The barcode is incomplete. The barcode cannot be scanned. Replace the thermal head.
Related part	Thermal print head, p/n 171875
Remarks	"Printer No.1" changes depending on error No.

■ Thermal head for printer 1 up (716-0001, 816-0001)

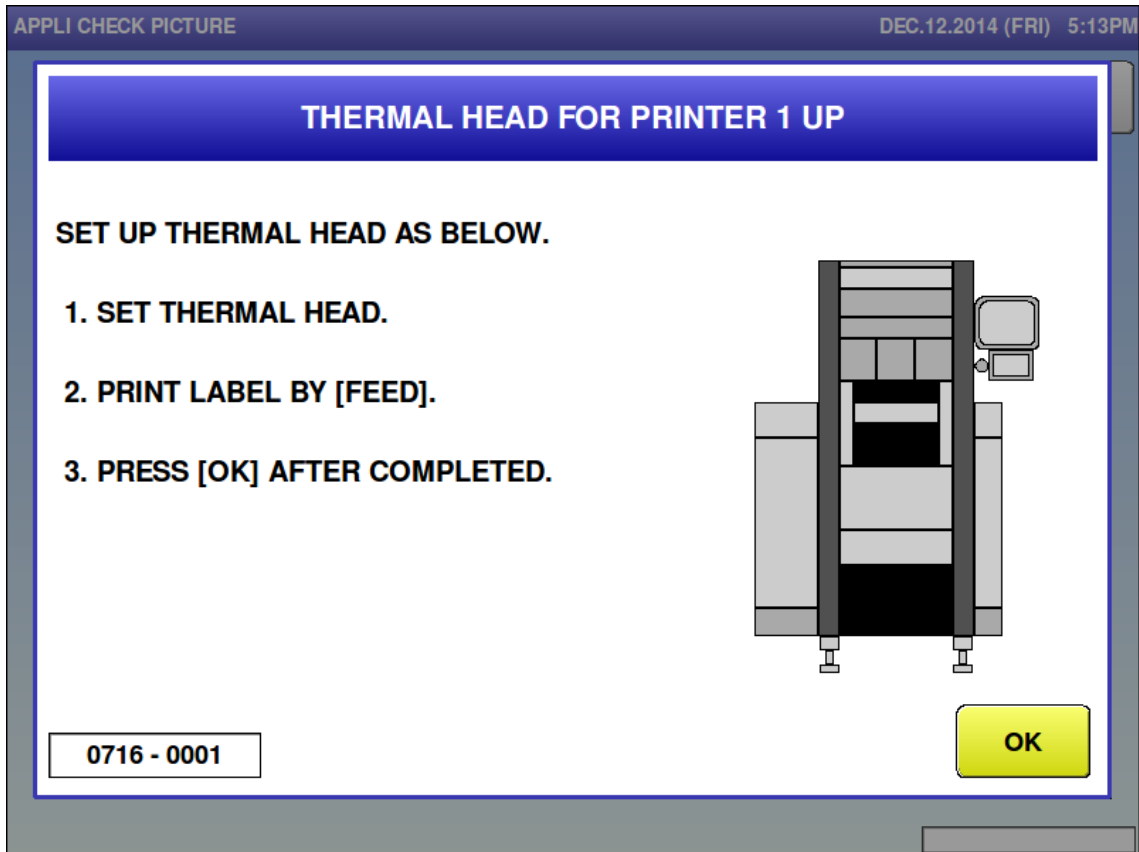

Error content	Thermal head for printer 1 up
Detail	The thermal head was up when printing starts.
Solution	Press the [OK] button after setting the thermal head
Action by user	
Action by service representative	
Related part	
Remarks	"Printer No.1" changes depending on error No.

6.2.5 Scale-related Error (No. 1600s)

- Span adjustment for scale is not completed (1601)

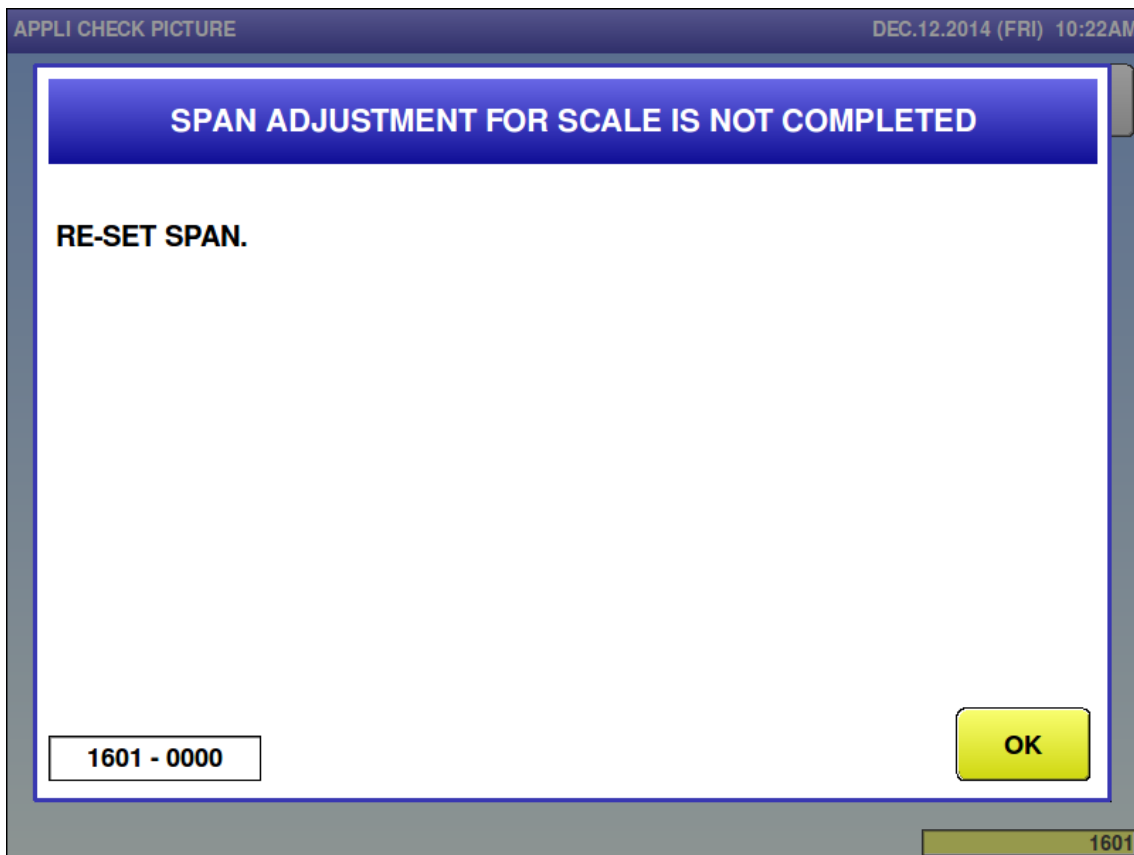

Error content	Span adjustment for scale is not completed.
Detail	The response from the scale is included in the sub-error
Solution	Press the [OK] button
Action by user	
Action by service representative	Calibrate the scale and press the button in the scale base to save the settings.
Related part	A/D board P-1111A-2 / A-7, p/n 171879
Remarks	The button in the scale base must be pressed after calibration is complete but before leaving the calibration screen.

■ Scale initialization is not completed (1602)

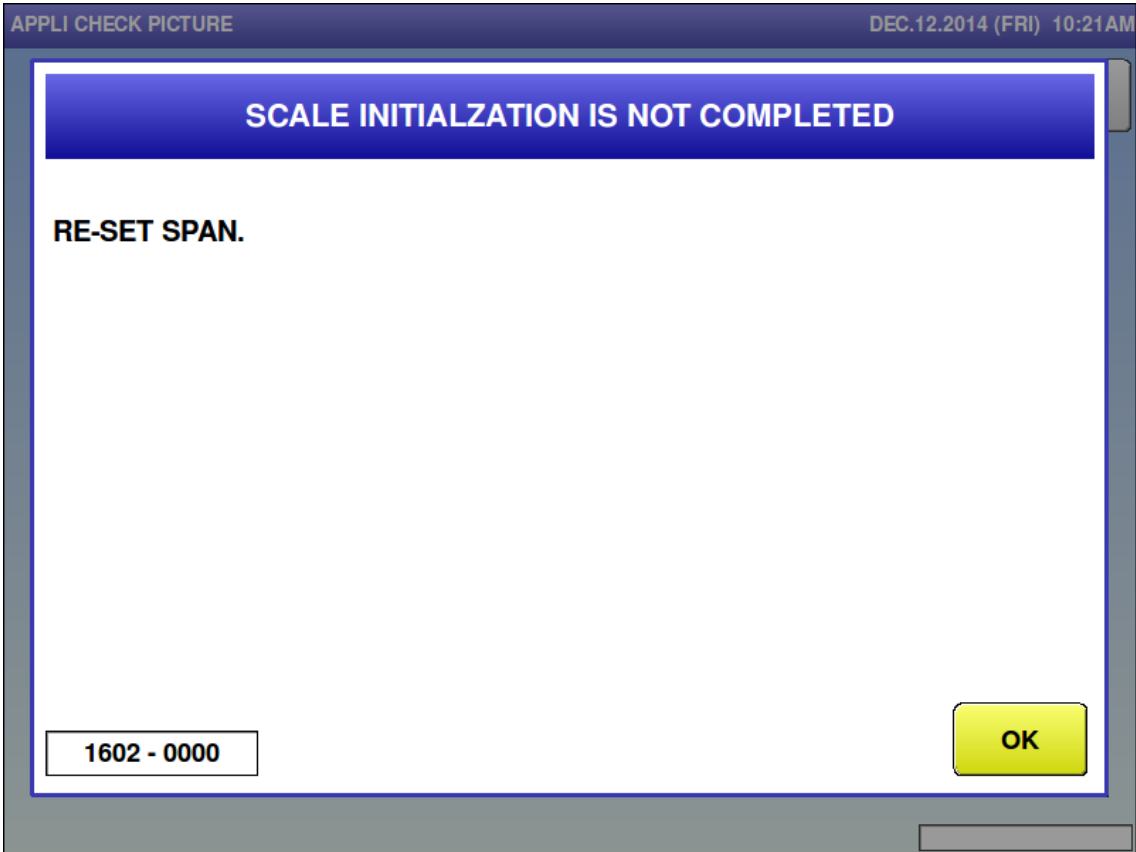

Error content	Scale initialization is not completed
Detail	The response from the scale is included in the sub-error.
Solution	Press the [OK] button
Action by user	
Action by service representative	Initialize and calibrate the scale then press the button in the scale base to save the settings.
Related part	A/D board P-1111A-2 / A-7, p/n 171879
Remarks	The button in the scale base must be pressed after calibration is complete but before leaving the calibration screen.

■ No response from scale (1621)

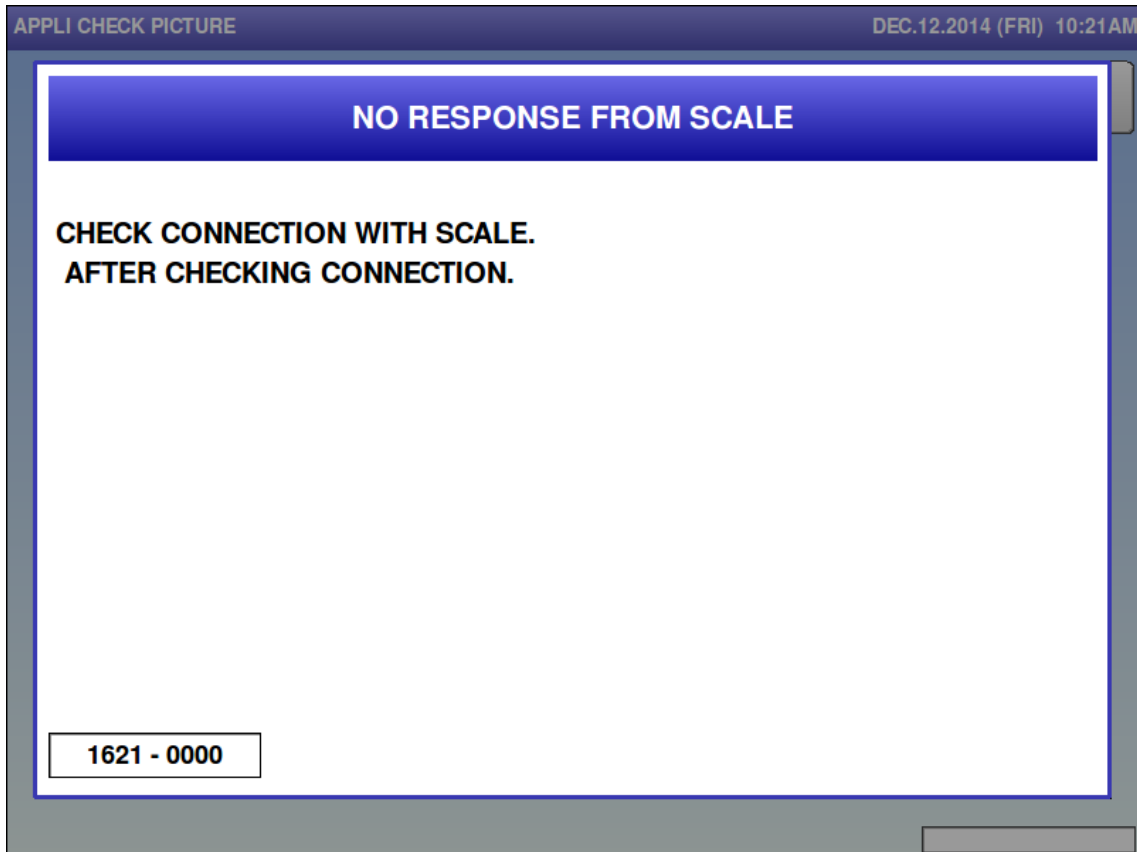

Error content	No response from scale.
Detail	
Solution	Turn off the power, wait 30 seconds, and then turn on the power again.
Action by user	Turn off the power, wait 30 seconds, and then turn on the power again.
Action by service representative	Determine if the A/D board is faulty or the connection from the A/D board to the main CPU board P-1100
Related part	A/D board P-1111A-2 / A-7, p/n 171879 Harness, C2, weigh communication, approx. 3 ft, p/n 185058 Harness, C2, weigh communication, approx. 7 ft, p/n 198254
Remarks	Restore power after checking scale connection.

■ Cannot communicate with scale (1622)

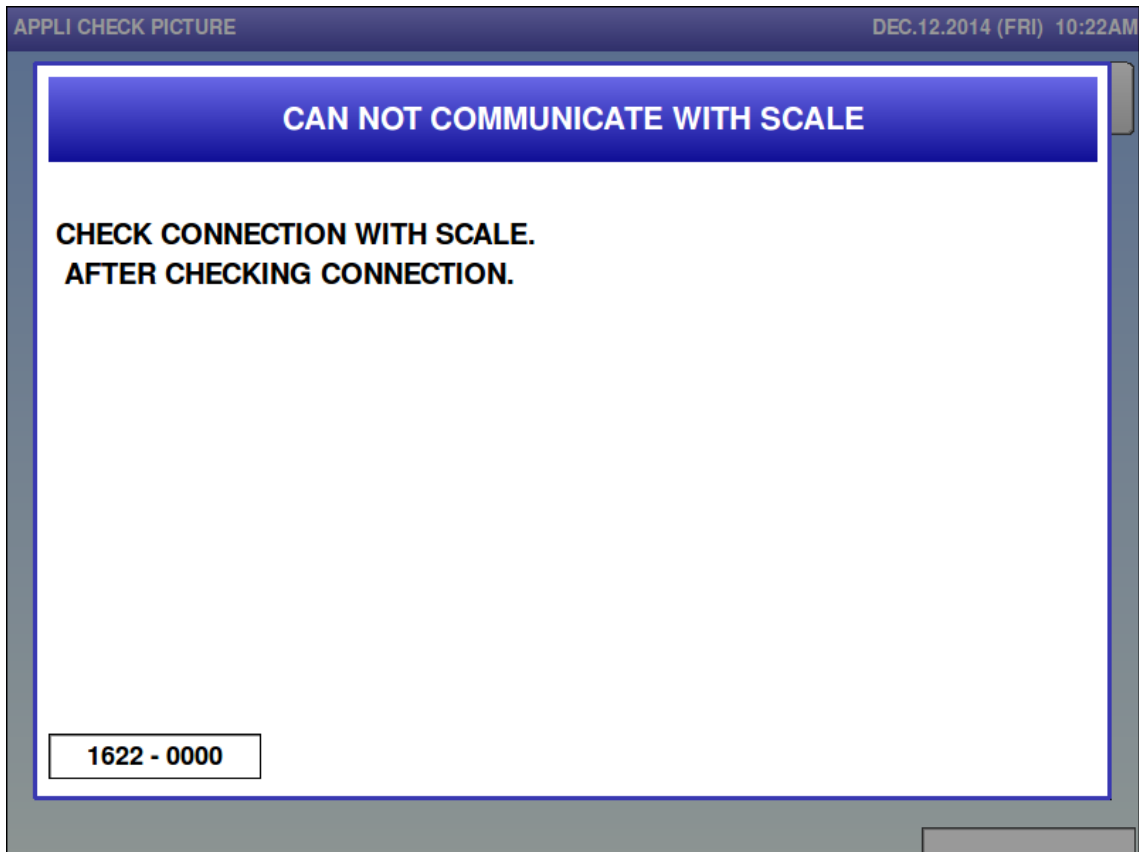

Error content	Cannot communicate with scale
Detail	
Solution	Turn off the power, wait 30 seconds, and then turn on the power again.
Action by user	Turn off the power, wait 30 seconds, and then turn on the power again.
Action by service representative	Determine if the A/D board is faulty or the connection from the A/D board to the main CPU board P-1100
Related part	A/D board P-1111A-2 / A-7, p/n 171879 Harness, C2, weigh communication, approx. 3 ft, p/n 185058 Harness, C2, weigh communication, approx. 7 ft, p/n 198254
Remarks	Restore power after checking scale connection.

6.2.6 Dialog Selection-related Error (No. 1800s, 4200s)

■ Checking clock setting (1801)

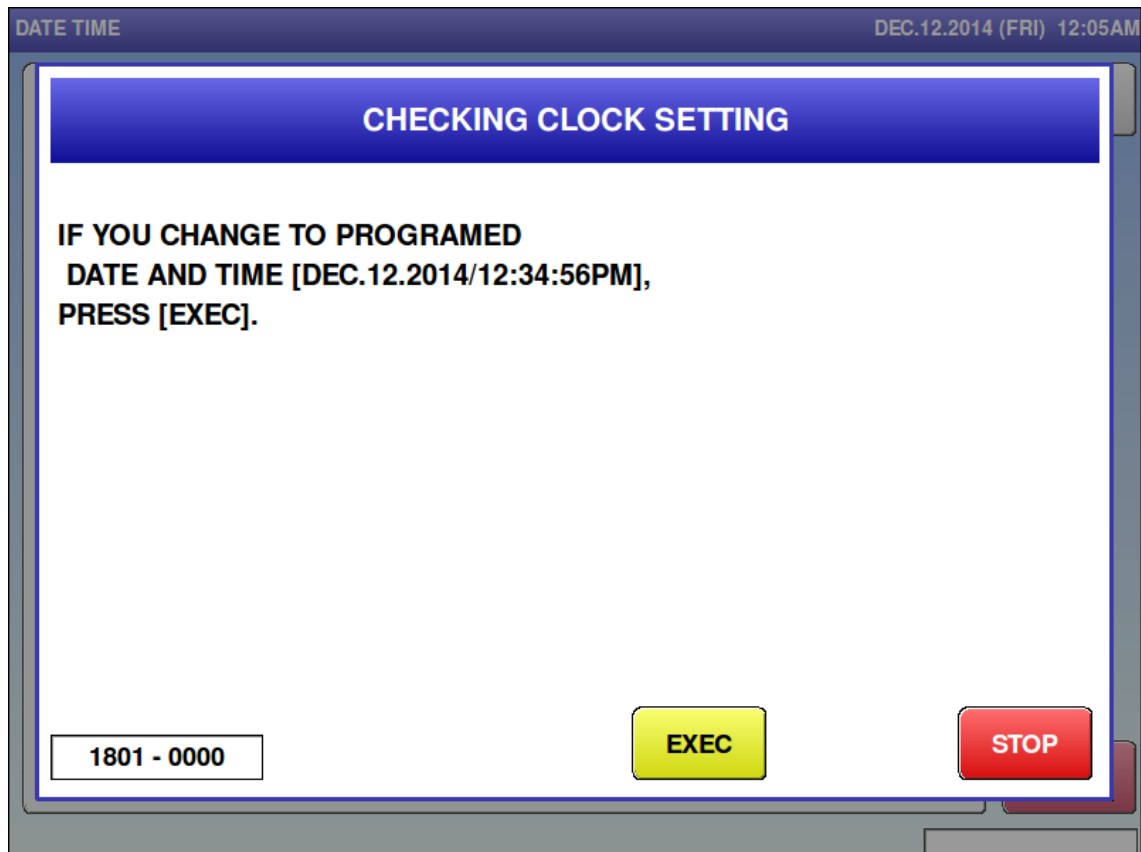

Error content	This message is displayed after changing the values for the machine's date and time.
Detail	
Solution	Press the [EXEC] button or the [STOP] button. [EXEC]: The date and time will be updated to the entered values. [STOP]: The date and time will not be updated and will remain at the current values.
Action by user	
Action by service representative	
Related part	
Remarks	[EXEC]: The date and time will be updated to the entered values. [STOP]: The date and time will not be updated and will remain at the current values.

■ Firmware update (1840)

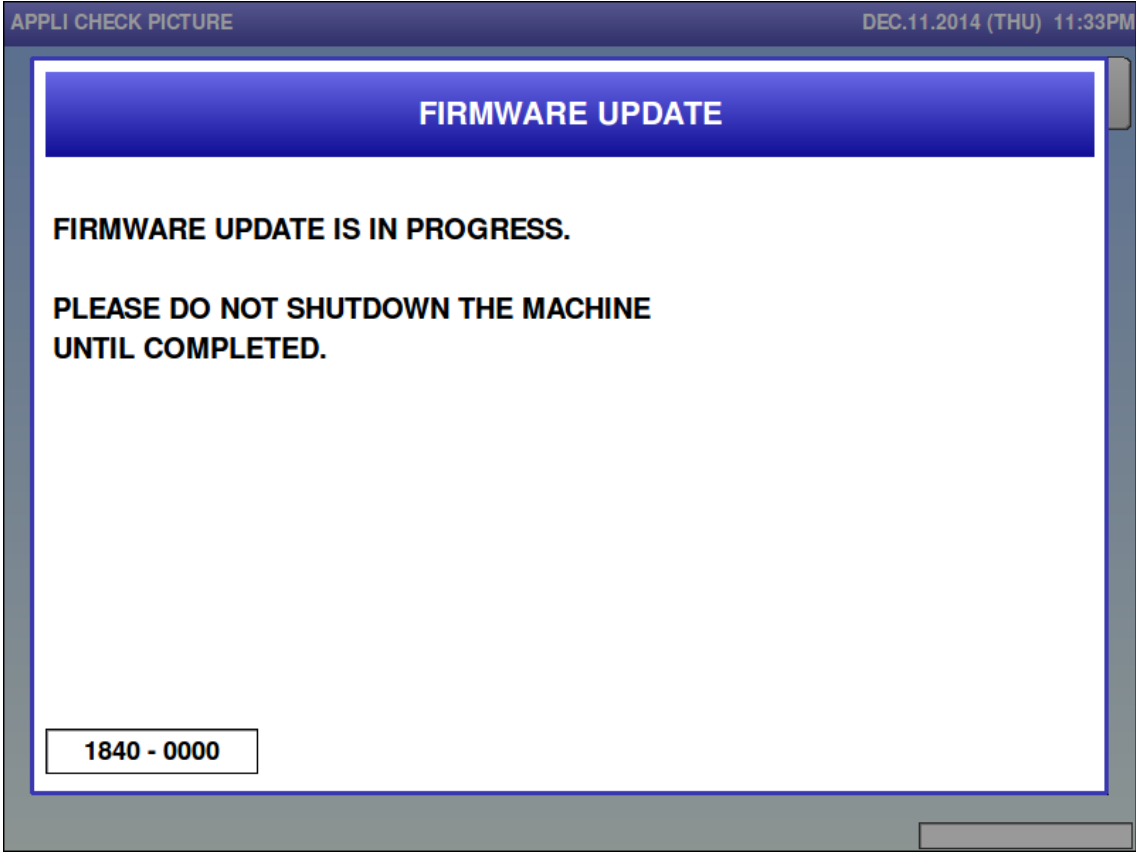

Error content	This message is displayed while the firmware is being updated.
Detail	Updating the program. Do not turn OFF the power.
Solution	
Action by user	
Action by service representative	
Related part	
Remarks	

- Firmware update is completed (1841)

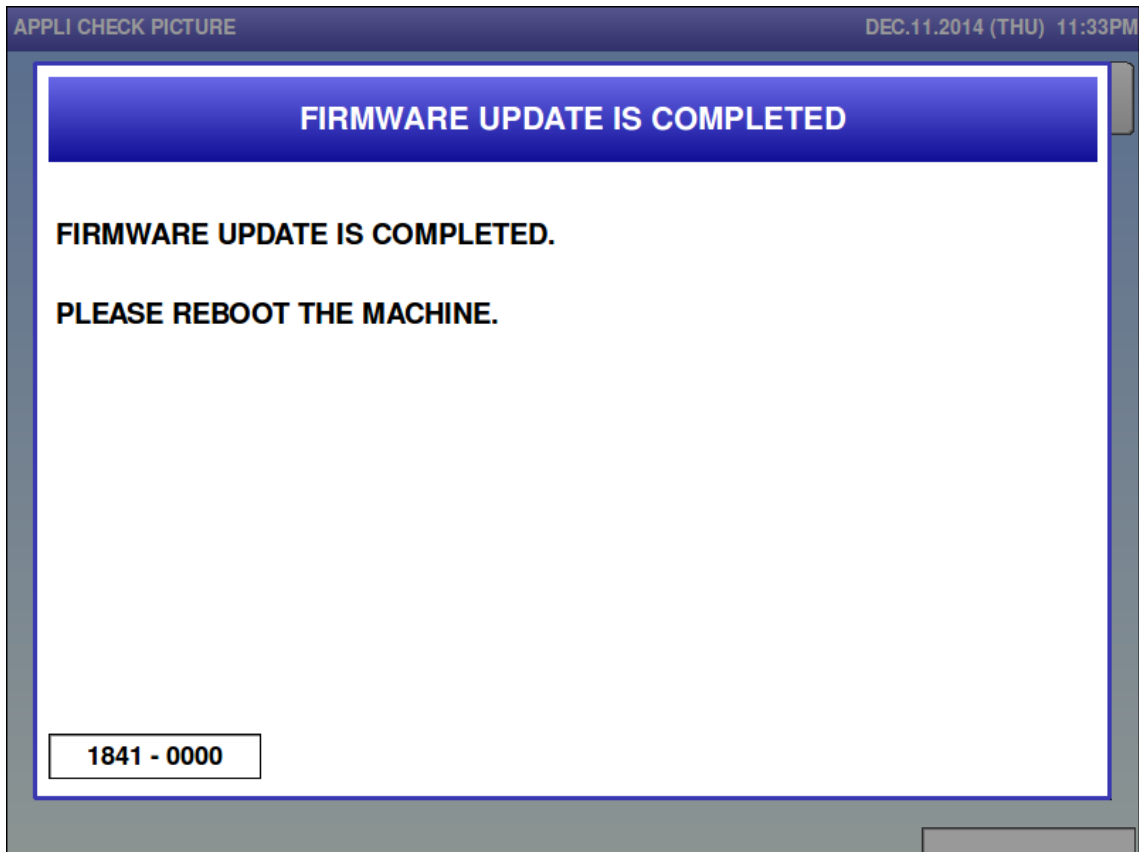

Error content	This message is displayed after the firmware update has been completed.
Detail	Program update has been completed. Turn off the power, wait 30 seconds, and then turn on the power again.
Solution	
Action by user	
Action by service representative	
Related part	
Remarks	

■ Power OFF (1842)

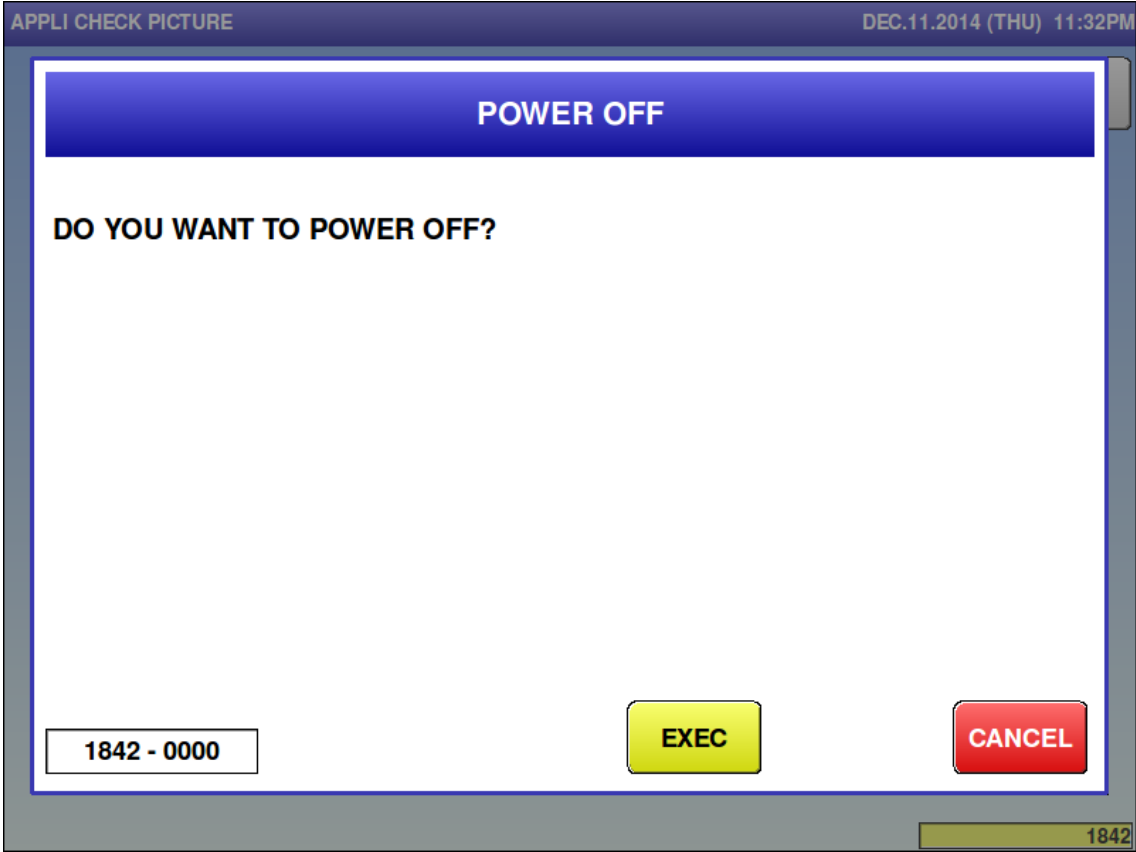

Error content	Confirmation to power down the IP-Ai scale.
Detail	Power OFF is checked when the power button is pressed.
Solution	Press the [EXEC] button or the [CANCEL] button. [EXEC]: Complete the power shut down sequence. [CANCEL]: Do not shut down the power and return to the previous screen when the power switch was pressed.
Action by user	
Action by service representative	
Related part	
Remarks	The IP-Ai only performs a "soft" power OFF. There is still power in the scale. Unplug before any maintenance.

■ Update program on remote (1860)

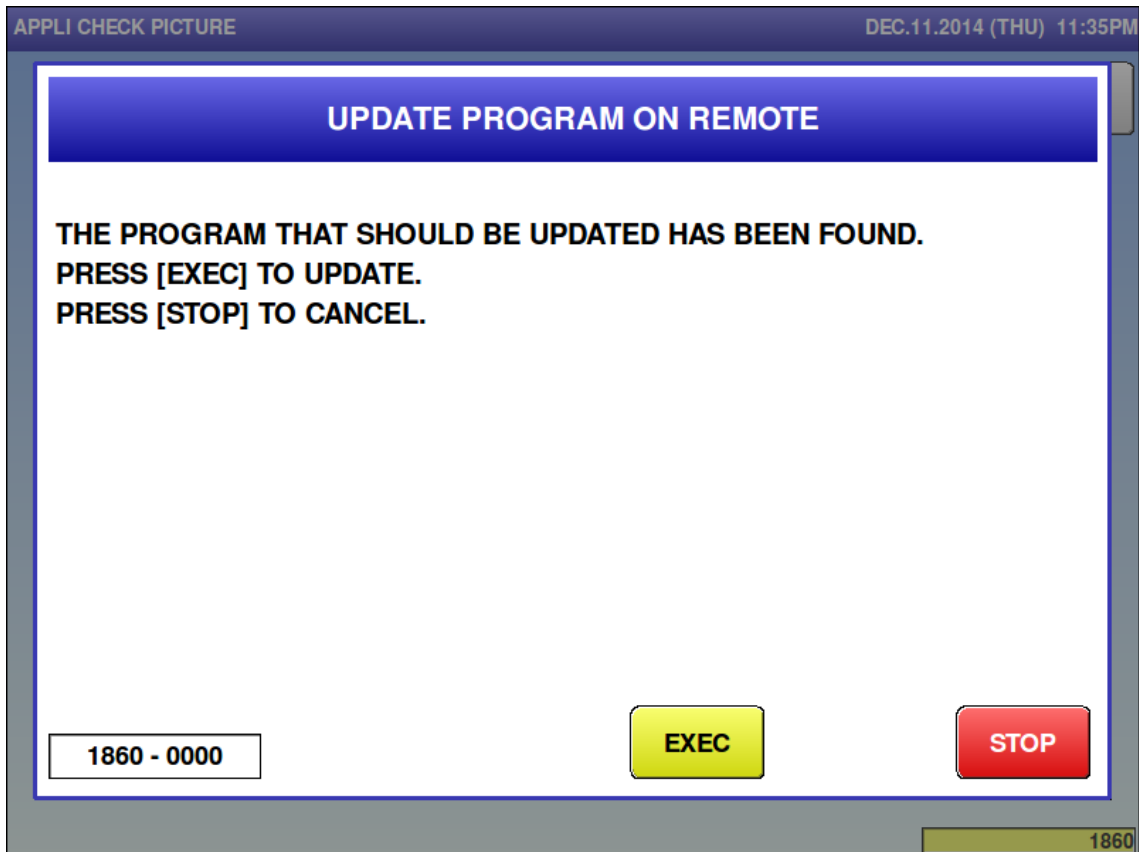

Error content	Confirm the program update remotely.
Detail	Update confirmation is performed when there is a program to be updated on the i global service when the power is ON.
Solution	Press the [EXEC] button to update the program from the cloud and restart after update. Press the [STOP] button to display clock confirmation.
Action by user	
Action by service representative	
Related part	
Remarks	Displayed when the i global service is enabled on [Settings: Machine No. (Global Service)], and there is an update program on the cloud service. IMPORTANT: The i-global service should not be enabled for any USA wrappers or scales.

■ Free 11 master is not registered (4201)

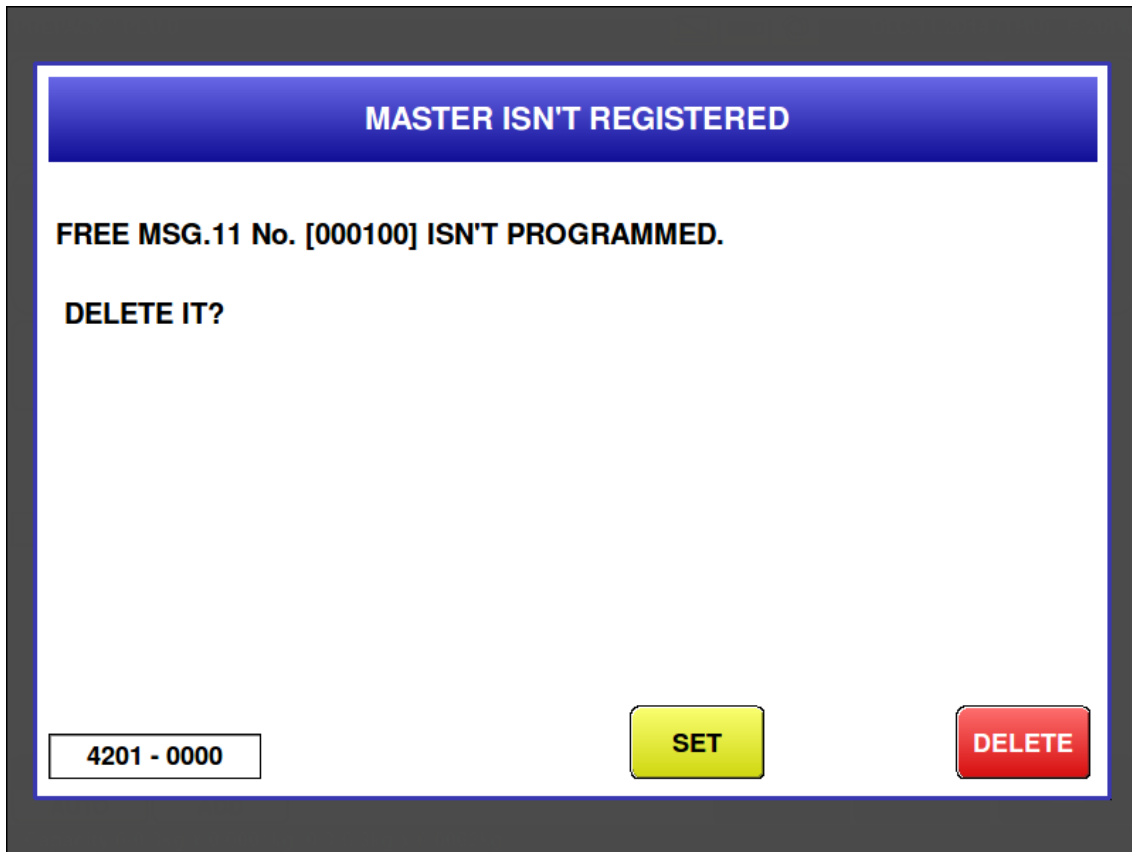

Error content	The called Free Message 11 is not found.
Detail	The message does not exist in the machine's memory.
Solution	Press the [DELETE] button or [SET] button. [DELETE] button => Delete the PLU's link with the Free Message 11. [SET] button => Cancel the error.
Action by user	Recheck the Free Message 11 message number. Program the Free Message 11 message.
Action by service representative	Recheck the Free Message 11 message number.
Related part	
Remarks	The error for a missing message linked to a PLU can be disabled in the Setup menu > Error Process > Call tab.

■ Free 12 master is not registered (4202)

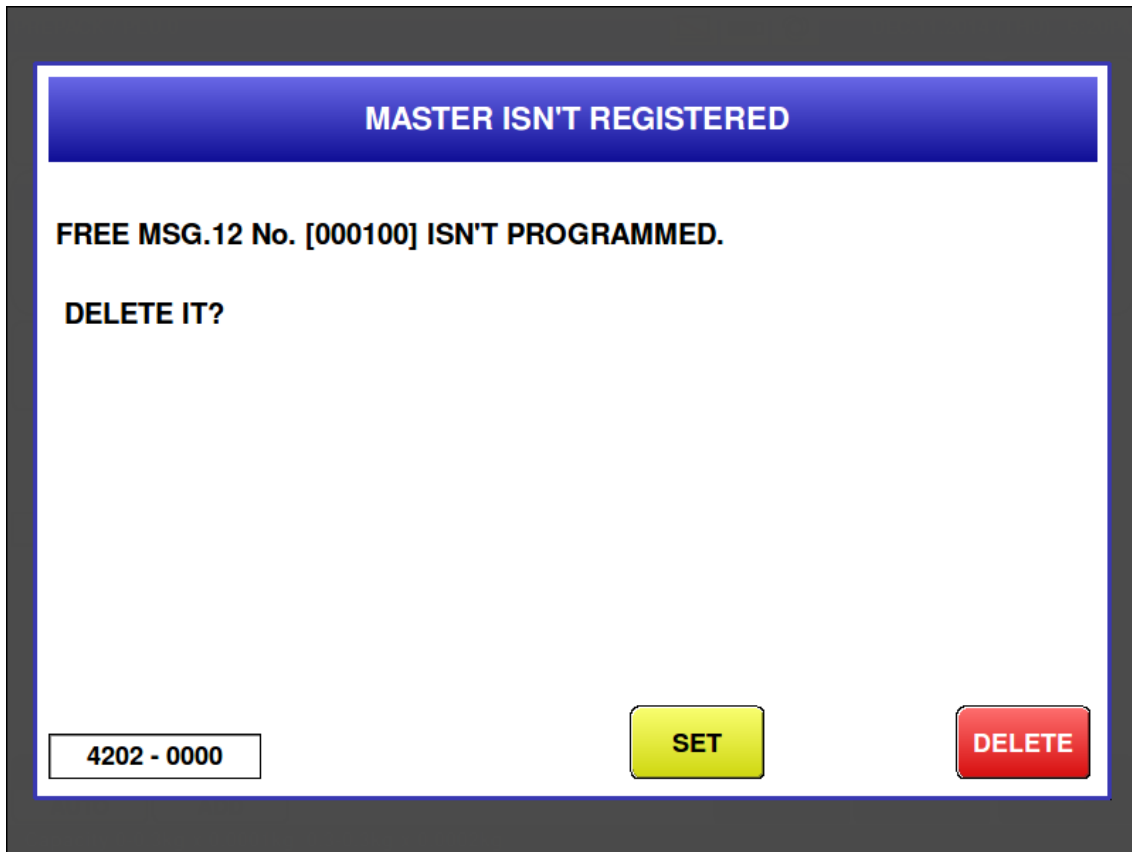

Error content	The called Free Message 12 is not found.
Detail	The message does not exist in the machine's memory.
Solution	Press the [DELETE] button or [SET] button. [DELETE] button => Delete the PLU's link with the Free Message 12. [SET] button => Cancel the error.
Action by user	Recheck the Free Message 12 message number. Program the Free Message 12 message.
Action by service representative	Recheck the Free Message 12 message number.
Related part	
Remarks	The error for a missing message linked to a PLU can be disabled in the Setup menu > Error Process > Call tab.

■ Free 13 master is not registered (4203)

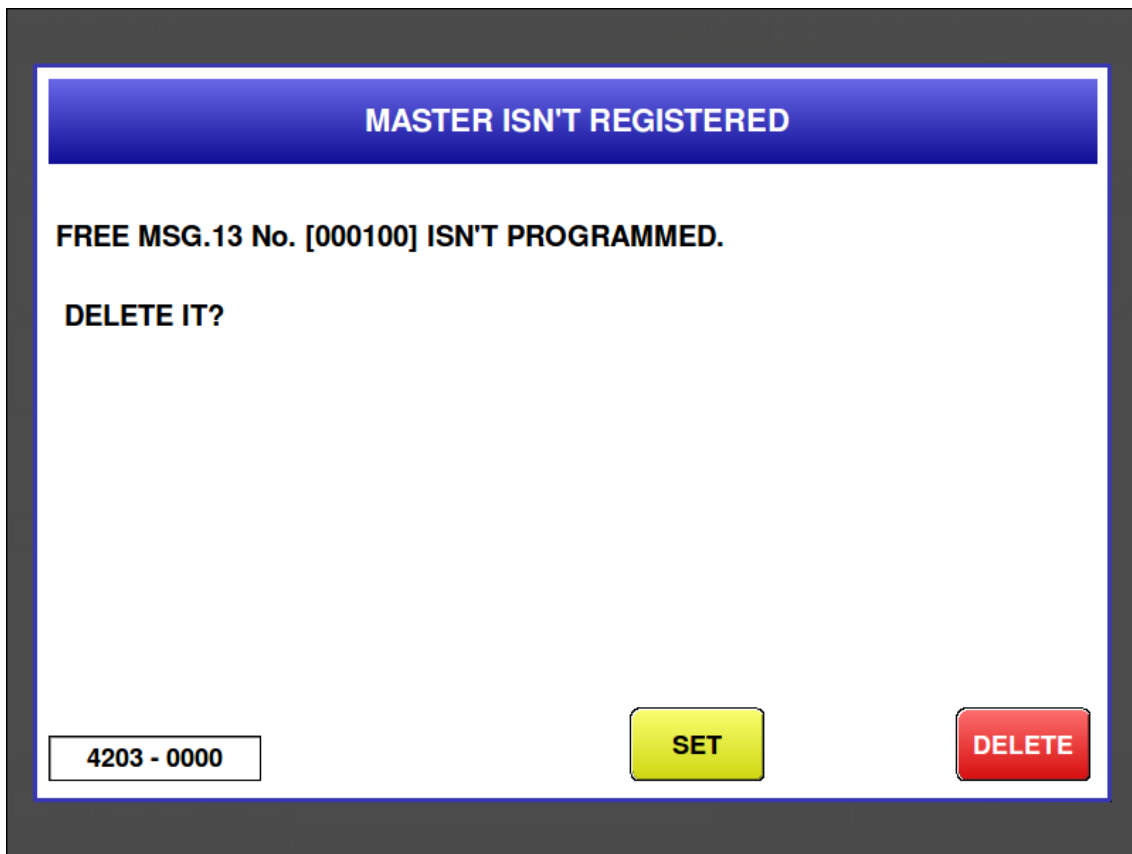

Error content	The called Free Message 13 is not found.
Detail	The message does not exist in the machine's memory.
Solution	Press the [DELETE] button or [SET] button. [DELETE] button => Delete the PLU's link with the Free Message 13. [SET] button => Cancel the error.
Action by user	Recheck the Free Message 13 message number. Program the Free Message 13 message.
Action by service representative	Recheck the Free Message 13 message number.
Related part	
Remarks	The error for a missing message linked to a PLU can be disabled in the Setup menu > Error Process > Call tab.

■ Free 14 master is not registered (4204)

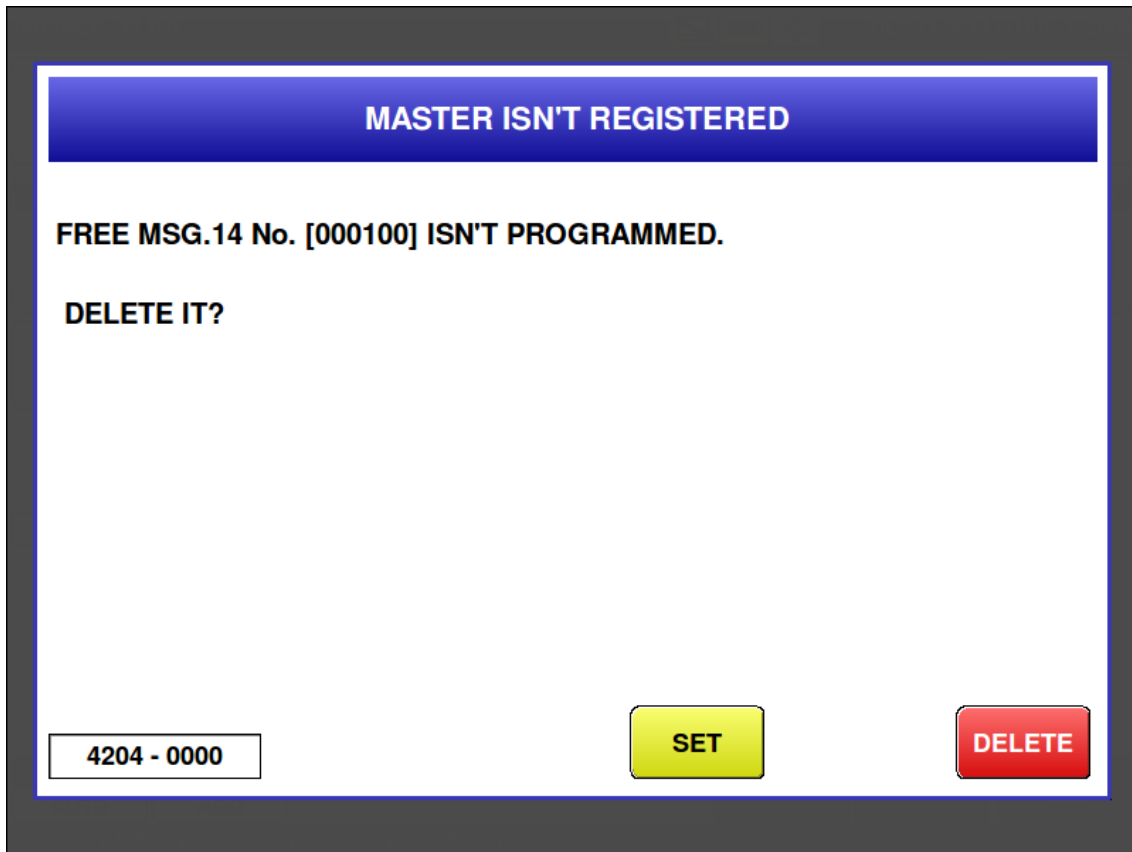

Error content	The called Free Message 14 is not found.
Detail	The message does not exist in the machine's memory.
Solution	Press the [DELETE] button or [SET] button. [DELETE] button => Delete the PLU's link with the Free Message 14. [SET] button => Cancel the error.
Action by user	Recheck the Free Message 14 message number. Program the Free Message 14 message.
Action by service representative	Recheck the Free Message 14 message number.
Related part	
Remarks	The error for a missing message linked to a PLU can be disabled in the Setup menu > Error Process > Call tab.

■ Free 15 master is not registered (4205)

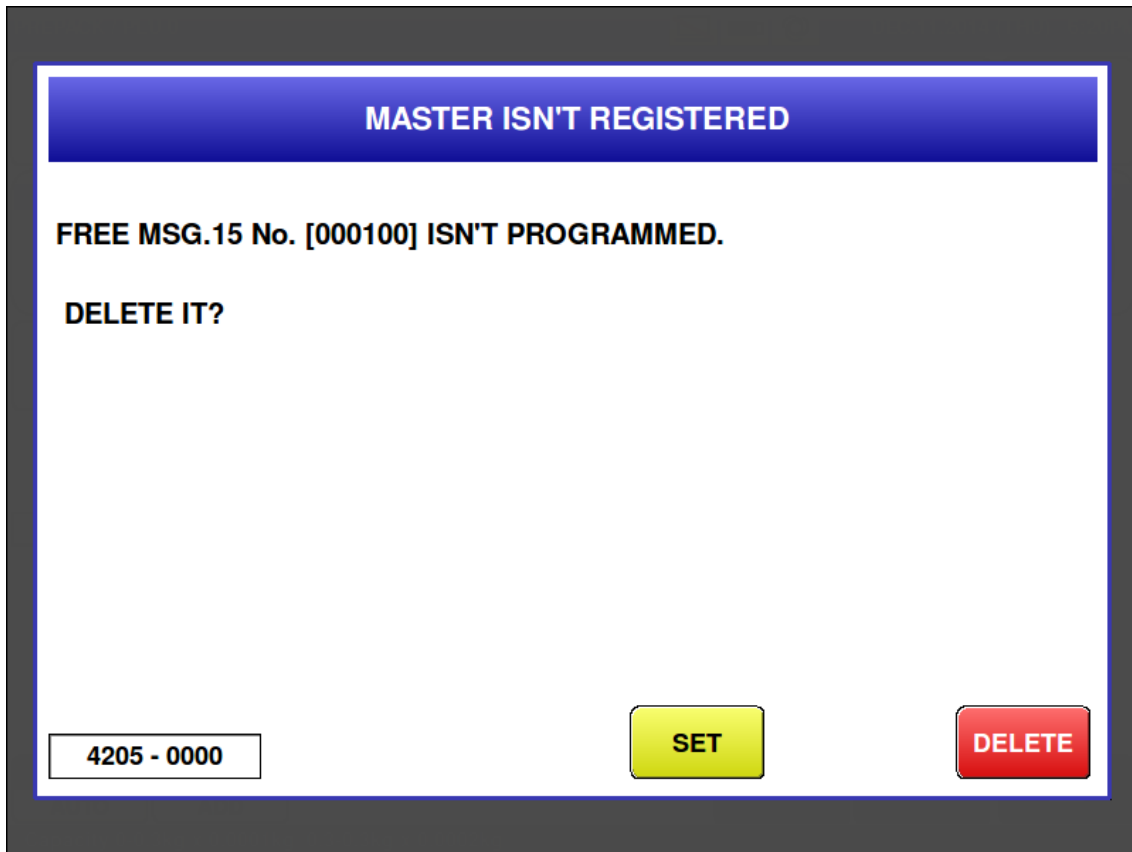

Error content	The called Free Message 15 is not found.
Detail	The message does not exist in the machine's memory.
Solution	Press the [DELETE] button or [SET] button. [DELETE] button => Delete the PLU's link with the Free Message 15. [SET] button => Cancel the error.
Action by user	Recheck the Free Message 15 message number. Program the Free Message 15 message.
Action by service representative	Recheck the Free Message 15 message number.
Related part	
Remarks	The error for a missing message linked to a PLU can be disabled in the Setup menu > Error Process > Call tab.

■ Coupon master is not registered (4206)

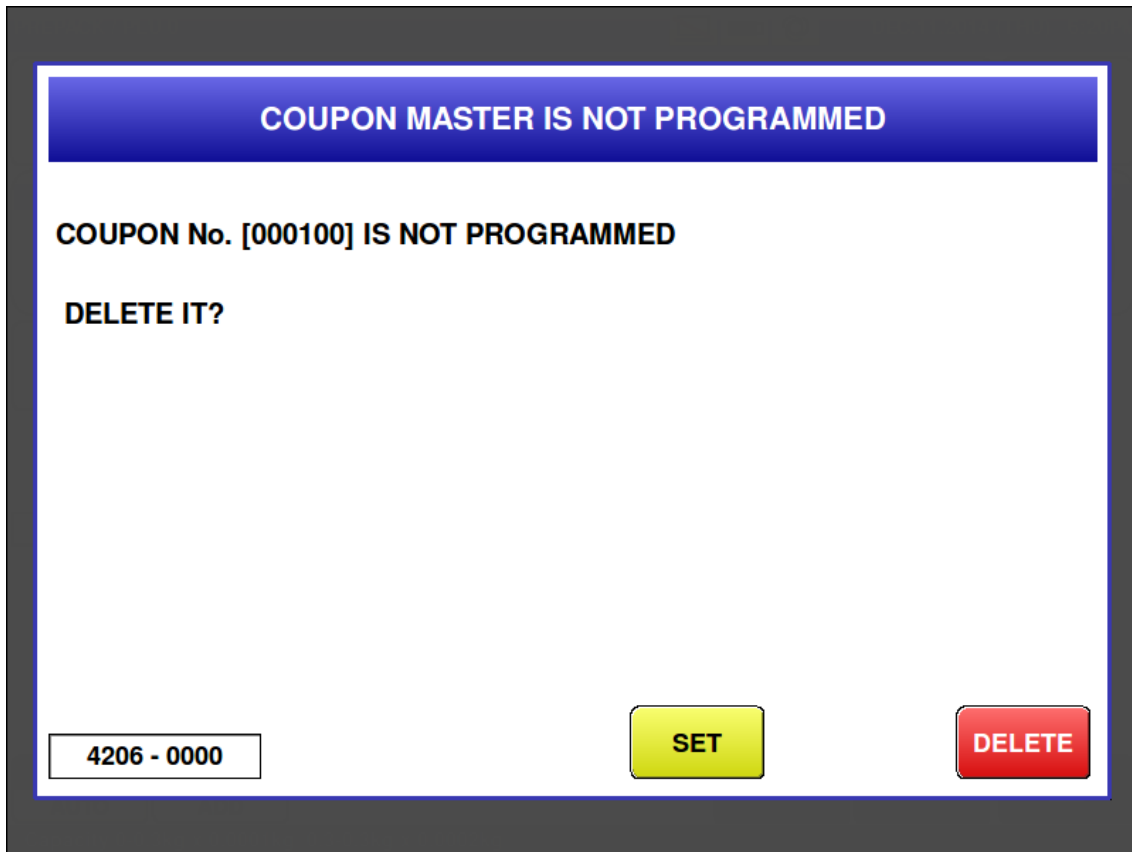

Error content	The called Coupon Message is not found.
Detail	The message does not exist in the machine's memory.
Solution	Press the [DELETE] button or [SET] button. [DELETE] button => Delete the PLU's link with the Coupon Message. [SET] button => Cancel the error.
Action by user	Recheck the Coupon Message message number. Program the Coupon Message message.
Action by service representative	Recheck the Coupon Message message number.
Related part	
Remarks	The error for a missing message linked to a PLU can be disabled in the Setup menu > Error Process > Call tab.

Chapter 7 Appendix

7.1 Operation Sequence

7.1.1 At Start-up



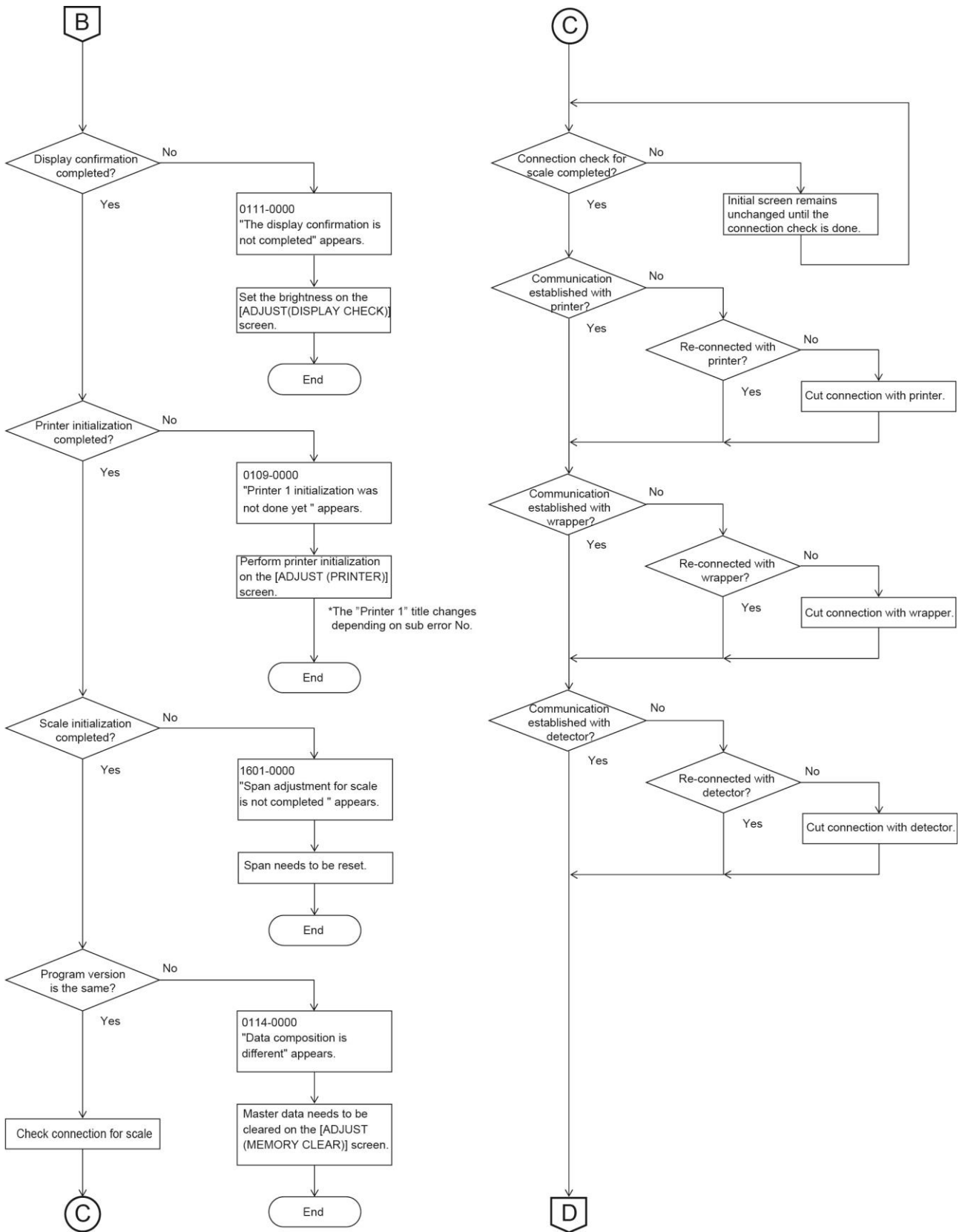

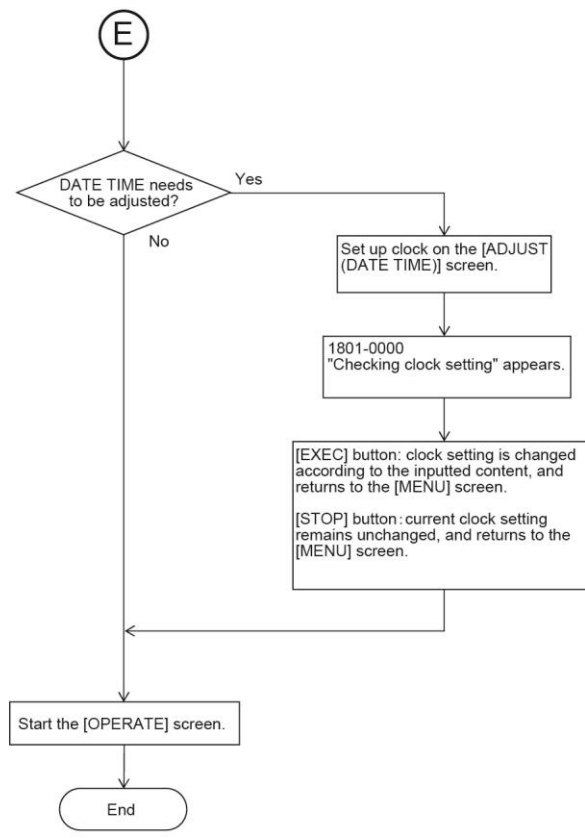
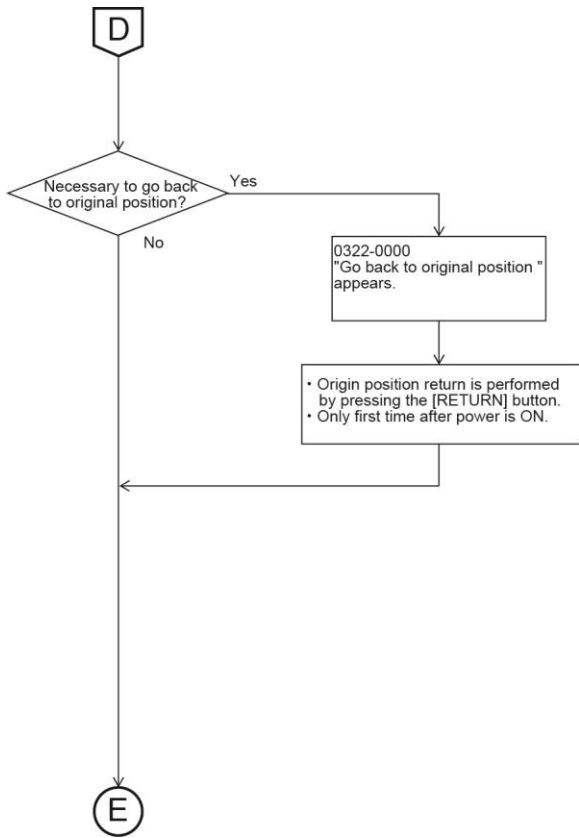

7.1.2 When Issuing Labels

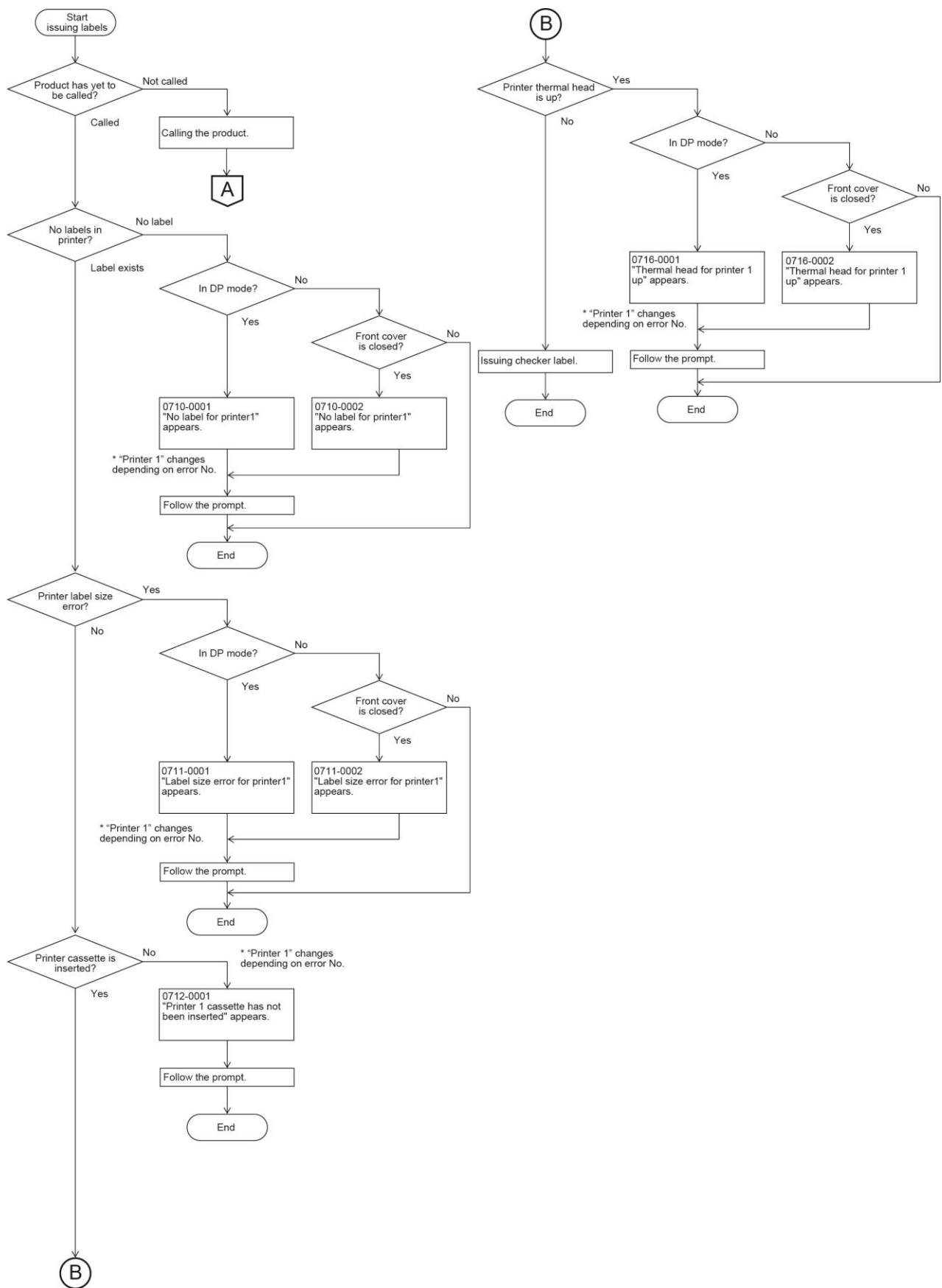

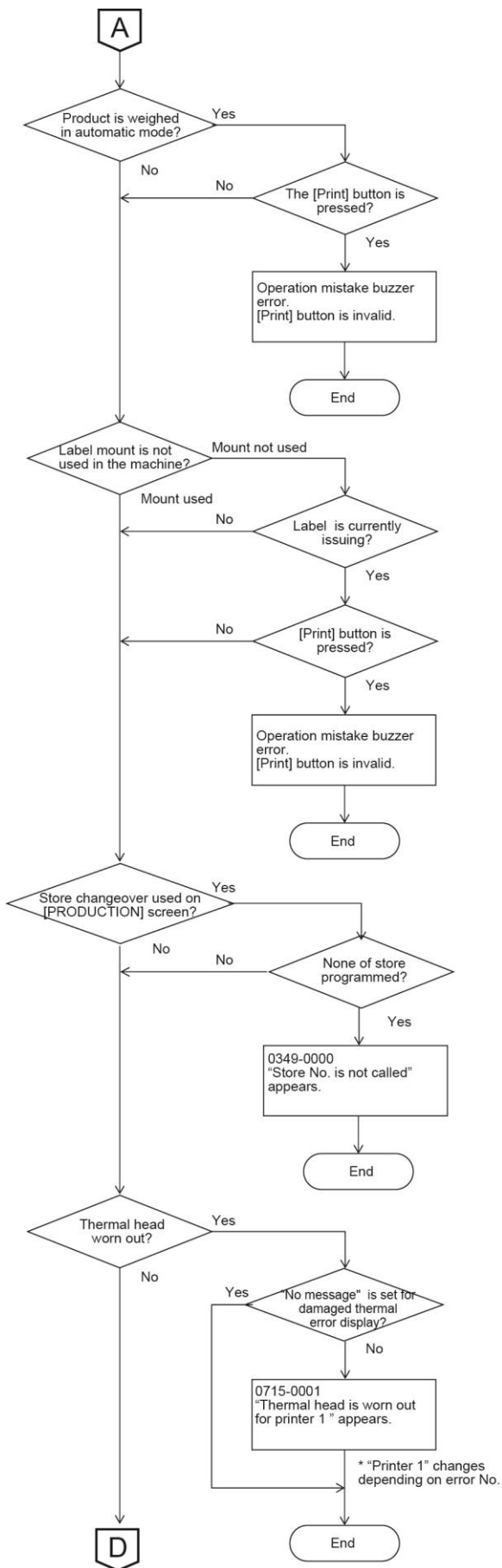

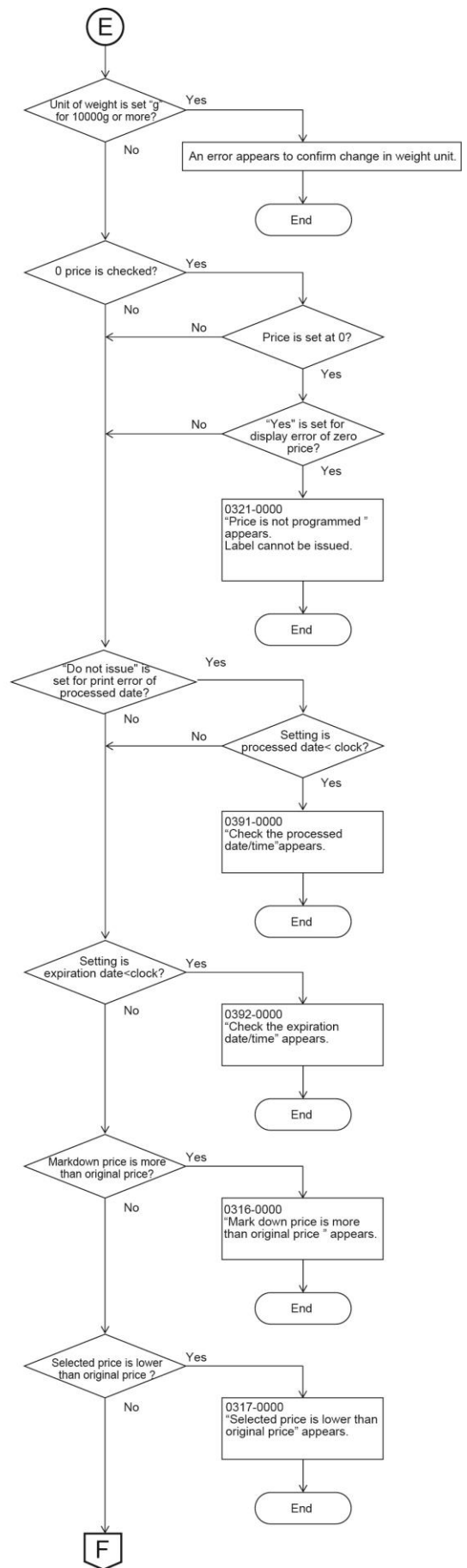
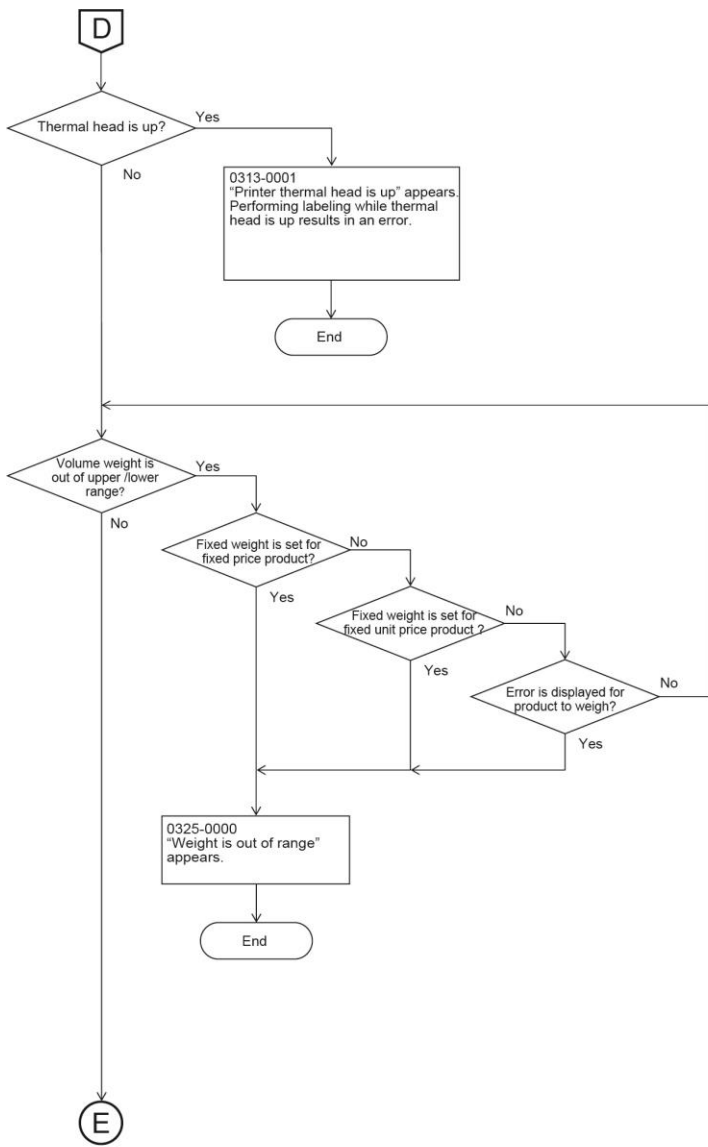

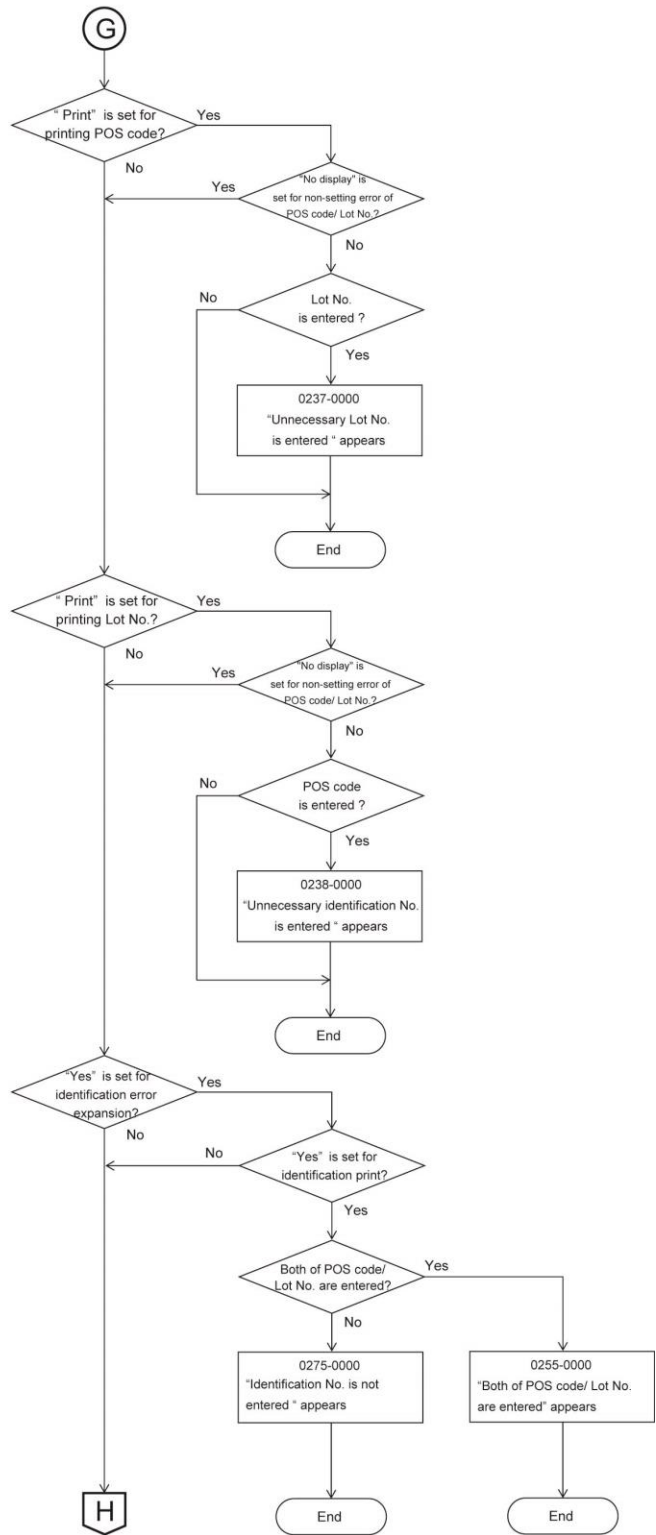
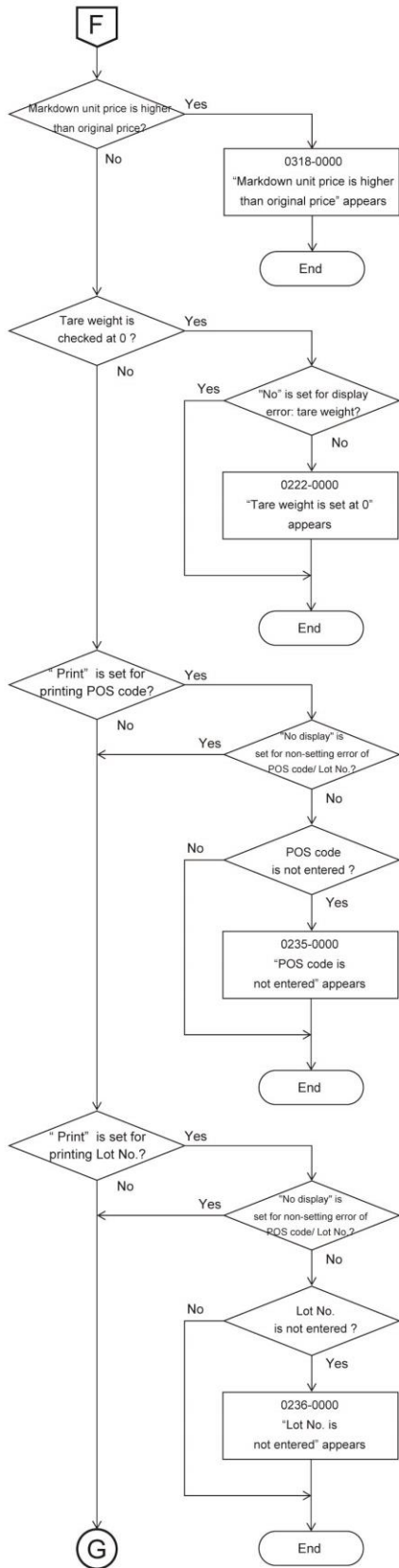

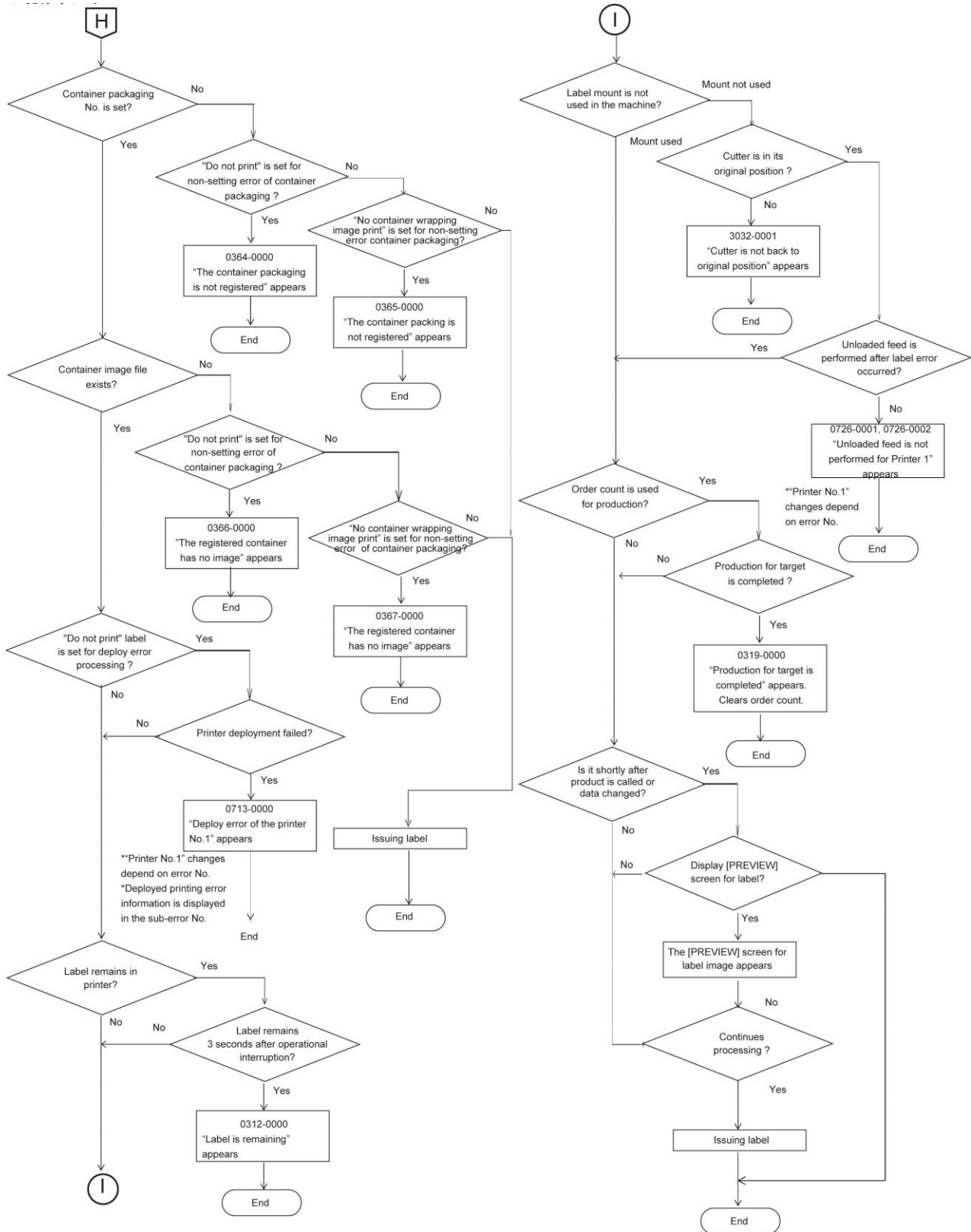

7.2 Wiring Diagrams

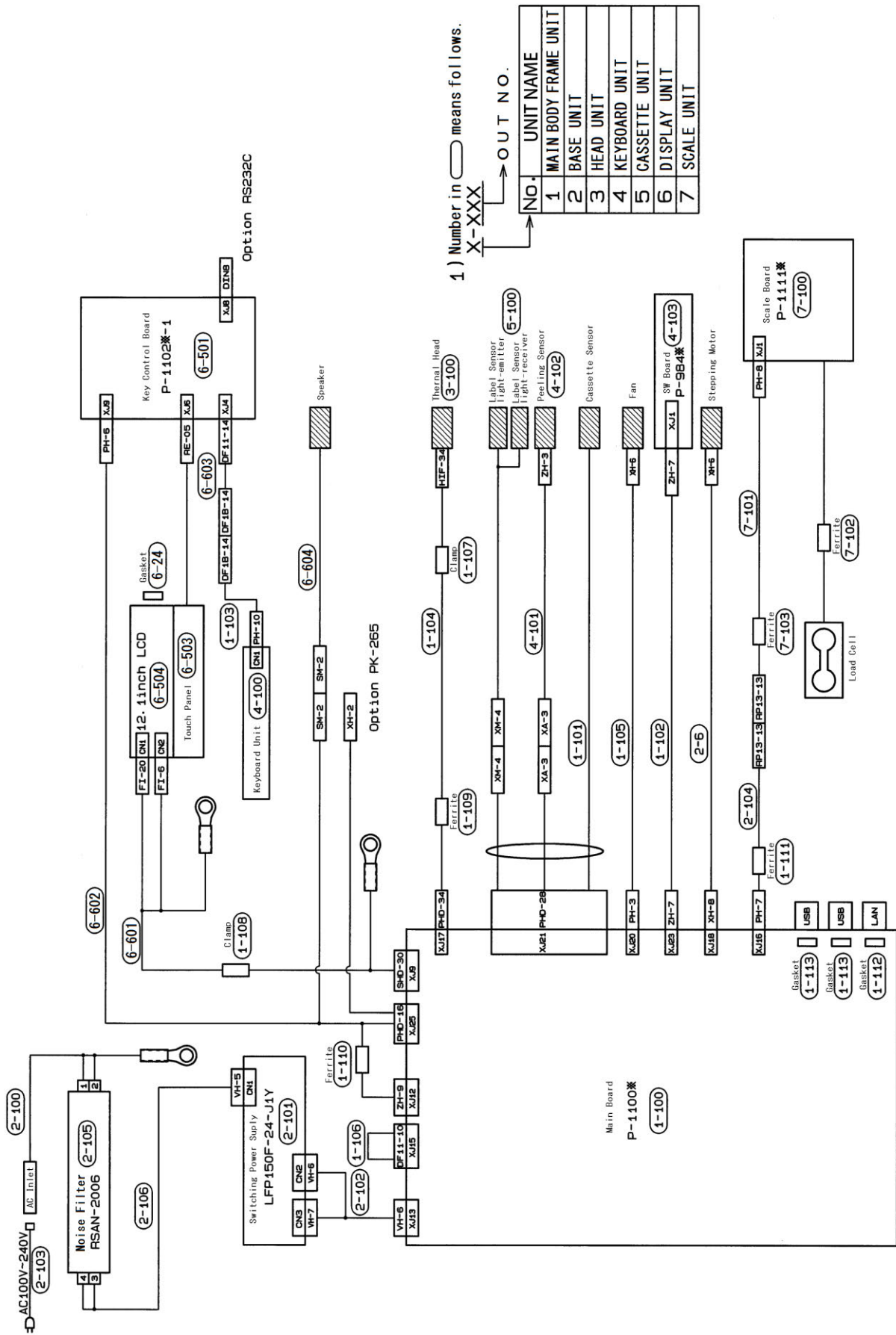

1) Number in means follows.
X-XXX

NO.	UNIT NAME
1	MAIN BODY FRAME UNIT
2	BASE UNIT
3	HEAD UNIT
4	KEYBOARD UNIT
5	CASSETTE UNIT
6	DISPLAY UNIT
7	SCALE UNIT



© Rice Lake Weighing Systems | Content subject to change without notice.

230 W. Coleman St. • Rice Lake, WI 54868 • USA
U.S. 800-472-6703 • Canada/Mexico 800-321-6703 • International 715-234-9171 • Europe +31 (0)26 472 1319