

System Scale Printer
AC-4000D
SERVICE MANUAL

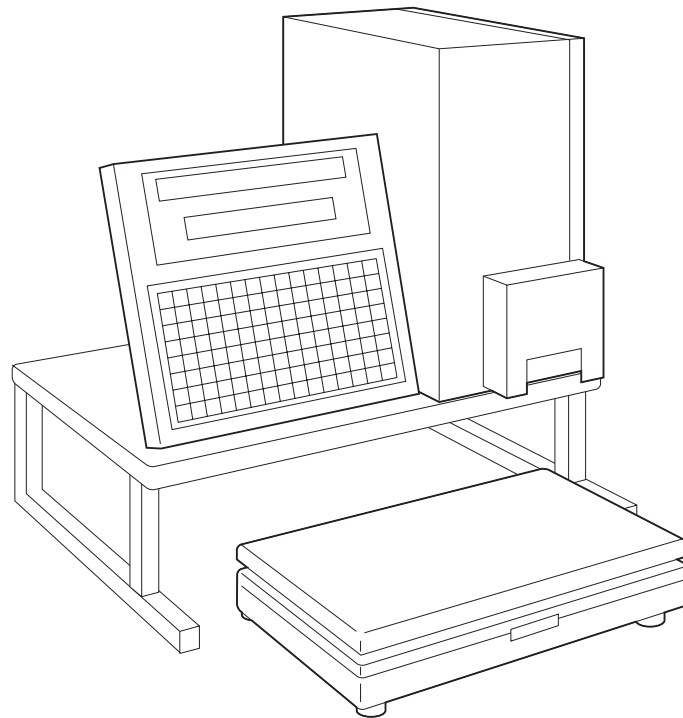

IMPORTANT

- Do not carry out installation, operation, service, or maintenance until thoroughly understanding the contents of this manual.
- Keep this manual available at all times for installation, operation, service, and maintenance.

To Provide Service Safely

In order to properly conduct maintenance and prevent the occurrence of accidents, be sure to perform the operations below.

- Turn OFF the power switch, and unplug the power cord from the outlet.
- Keep the area around the machine clean.
Particularly with disassembly, if the power is switched ON when an object such as a detached screw is left inside the main unit, serious damage may occur.
- Do not pull directly on the cords of the internal wiring. Doing so may result in broken wires or poor connections. Always grasp the connector when plugging/unplugging a cord.
Pay particular attention to the thermal head cable.
- The thermal head and print head can be easily scratched, so be careful when cleaning them.
- Cautions are explained for each point of assembly and adjustment. To ensure proper operation, read this manual thoroughly so that you fully understand it.

You can help improve this manual by calling attention to errors and by recommending improvements. Please convey your comments to the nearest Ishida Company regional representative. Thank you!

Copyright © 2006 by Ishida Co., Ltd. All Rights Reserved.

No part of this manual may be reproduced in any form, by mimeograph or any other means, without written permission of the publisher.



SERVICE SAFETY

For correct maintenance, and to prevent accidents, please adhere to the following items during service.

- Ensure that the power switch is OFF before any maintenance work and remove the power cable from the main power outlet.
- Keep the machine surroundings clean and tidy. Take additional care, especially during disassembly, not to leave screws etc. inside the machine as this may lead to serious injury.
- Do not pull internal wiring cables as cable breaks, poor contact, etc. may take place. Always hold the connector end before removing. Take special care with thermal head cable, where poor contact may lead to damage.
- Take care when cleaning thermal heads and print heads, as these are easily damaged.
- There are precautions relating to assembly and adjustment parts. Read and understand the manual thoroughly before attempting maintenance.



SAFETY CONSIDERATIONS

For safe operation, the following safety considerations must be observed.

Grounding

This machine requires protective grounding for safe operation. To avoid potential shock hazards, a protective grounding conductor for the machine must be securely connected to the main grounding provision by qualified service personnel.

Do not remove covers or enclosures

To avoid personal injury and shock, do not open or remove any covers or enclosures of the machine unless specified in the manual.

Do not perform unspecified maintenance

For your personal safety, do not perform any maintenance procedures which are not specified in the manual.

Disconnect power supply before servicing

To ensure your personal safety, disconnect the power supply before servicing.

⚠ CAUTIONS FOR USE

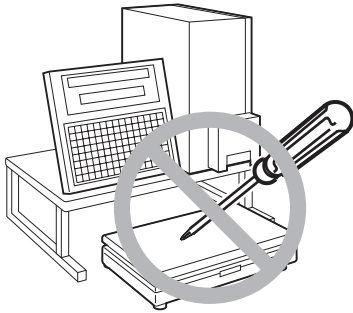

- ▶ Do not disassemble the machine.

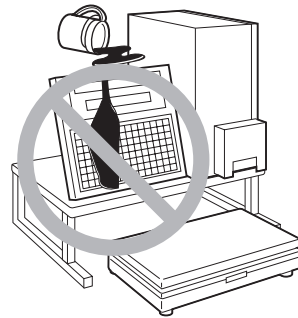

- ▶ Do not allow any liquids to come into contact with the machine.

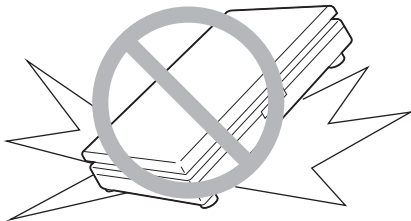

- ▶ Do not drop or apply a strong shock to the scale.



- ▶ When cleaning the machine, only use a soft dry cloth or a cloth wetted with a neutral cleanser. Never use thinner or other volatile liquids.

Power Supply

- Use the appropriate voltage after referring to the specification plate located on the machine.
- Use a dedicated power source.
(Voltage fluctuation may cause the machine to malfunction)

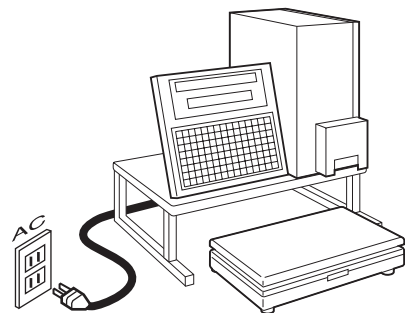

⚠ CAUTIONS FOR INSTALLATION

Avoid the following areas when installing the machine

- Areas subject to high temperatures or high humidity
- Areas exposed to direct sunlight
- Areas where water or other liquids are easily spilled on the machine
- Areas subject to excessive vibration or unstable surfaces
- Areas exposed to direct cold air
- Areas subject to low temperatures

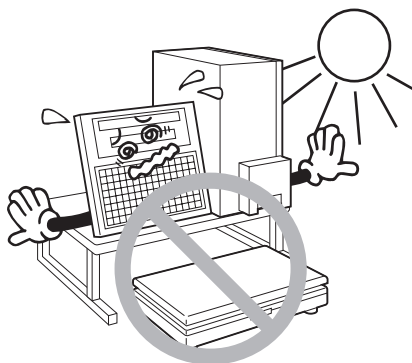

- Areas subject to a lot of dust or dirt
- Areas with large voltage fluctuations

- Areas where the scale is not level

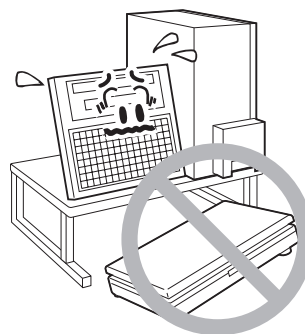
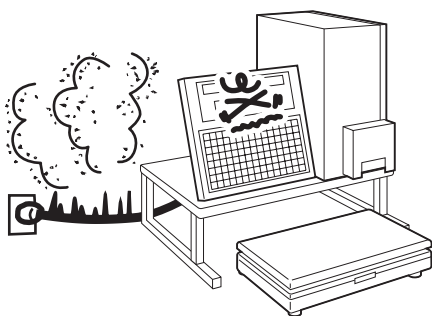

Level adjustment

- Always ensure that the machine is level. If the machine is not level, weighing may not be accurate.
- Adjust the machine to a level position using the four level adjustment feet located on the bottom of the machine, until the bubble is completely centered in the round level indicator.

Level adjustment foot

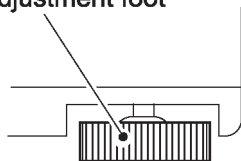

Level indicator



Contents

CHAPTER 1 OVERVIEW

1.1 Appearance and Name of Each Part	1-1
1.2 Display	1-1
1.3 Key Sheet	1-2
1.4 Printer	1-2
1.5 Main Specifications	1-3
1.6 Layout of components	1-4

CHAPTER 2 INSTALLATION

2.1 Packed Goods	2-1
2.2 Installation Environment	2-2
2.3 Installing the stand	2-2
2.4 Connecting the cable	2-3
2.5 Label Loading	2-3
2.6 Power Cable Connection	2-5
2.7 Power Switch "ON"	2-5
2.8 Customer's Specification Setup (Initialization, Setup, and Registration)	2-6
2.9 Normal Mode Display	2-7
2.10 Label Batch Print Mode	2-8
2.10.1 Basic operation	2-8
2.10.2 Additional functions	2-9
2.10.3 Label batch printing on continuous paper	2-9
2.11 Scroll Message Display	2-10
2.12 Campaign Function	2-10

CHAPTER 3 TEST MODE

3.1 Test Mode Menu List	3-1
3.2 Test Mode Start	3-2
3.3 Hardware Test	3-2
■A/D check	3-2
■KEY CHECK	3-4
■DISPLAY CHECK	3-4
■RS232C CHECK	3-5
■APPLICATION PROGRAM No.	3-5
■BIOS PROGRAM No.	3-6
3.4 RAM Clear	3-7
■SRAM CLEAR	3-7
■SETUP CLEAR	3-8
■TEST DATA SET	3-8
■APPLICATION COPY	3-9
■BIOS COPY	3-9
■BOOT COPY	3-10

3.5	Printer Head	3-11
	■PRINTER HEAD	3-11
	■RESISTANCE	3-11
	■PRINT USAGE IN km	3-12
3.6	Label Sensor Check	3-13
3.7	Total Memory	3-14
3.8	ROM Switch	3-15
3.9	Peel Sensor Check	3-17
3.10	Machine Type Check	3-18

CHAPTER 4 SETUP MODE

4.1	Setup Mode Menu	4-1
4.2	Starting Procedure for Each Mode	4-2
4.3	Starting Procedure for Setup Mode	4-2
4.4	Label Format [Print conditions]	4-3
	■LABEL FORMAT No.	4-3
	■LABEL LENGTH + GAP	4-3
	■LABEL WIDTH	4-4
	■LABEL SENSOR DISTANCE	4-4
	■LABEL DIE-CUT, CONTINUOUS	4-4
	■STORE NAME, ADDRESS	4-4
	■FIELD TITLE PRINT	4-5
	■PEEL SENSOR	4-5
	■TEST ITEM No.	4-5
	■THERMAL HEAD CHECK	4-5
	■SUBTOTAL LABEL FORMAT No.	4-6
	■STORE No. PRINT	4-6
	■MACHINE No. PRINT	4-6
	■LABEL FORMAT EDIT	4-7
	■FORMAT No. + [PLU]	4-7
	■UNIT	4-8
	■DEFAULT PLU	4-8
	■UNIT DATA	4-9
	■NUMBER OF UNITS	4-9
	■LABEL LENGTH	4-9
4.5	POS Code	4-10
	■POS FLAG 8/3	4-10
	■10 DIGIT FLAG 8/13	4-10
	■POS TYPE	4-10
	■BAR TYPE	4-11
	■ITF	4-12
	■MANUFACTURE CODE	4-12
4.6	Item Code	4-13
	■BARCODE POSITION	4-13
	■DEPARTMENT CODE	4-13
	■GROUP CODE	4-13

4.7	Default Data	4-14
	■DATE PRINT FLAG	4-14
	■USED BY	4-14
	■PACKING TIME FLAG	4-14
	■EXPIRY TIME FLAG	4-15
	■BEST BEFORE FLAG	4-15
	■BEST BEFORE DATE	4-15
	■UNIT TYPE	4-15
4.8	Total Mode Select	4-16
	■DAILY TOTAL	4-16
	■WEEKLY TOTAL	4-16
	■MONTHLY TOTAL	4-16
4.9	Open Price	4-17
4.10	PLU Select	4-18
	■SALES MODE	4-18
	■UNIT PRICE	4-18
	■MD (Mark Down) FLAG	4-18
	■MD (Mark Down) PRICE	4-18
	■FIXED WEIGHT	4-19
	■PCS (Quantity)	4-19
	■TARE	4-19
	■DATE PRINT	4-19
	■USED BY	4-19
	■BEST BEFORE DATE FLAG	4-20
	■BEST BEFORE DATE	4-20
	■PACKING TIME FLAG	4-20
	■PACKING TIME DATA	4-20
	■EXPIRY TIME FLAG	4-20
	■EXPIRY TIME DATA	4-21
	■ITEM CODE	4-21
	■BARCODE TYPE	4-21
	■POS CODE TYPE	4-21
	■POS CODE FLAG	4-21
	■POS CODE	4-22
	■OPEN PRICE	4-22
	■EXTRA MESSAGE 1	4-22
	■EXTRA MESSAGE 2	4-22
	■EXTRA MESSAGE 3	4-22
	■COUPON MESSAGE	4-23
	■LOGO IMAGE 1	4-23
	■LOGO IMAGE 2	4-23
	■LABEL FORMAT No.	4-23
	■UPPER LIMIT	4-23
	■LOWER LIMIT	4-24
	■UNIT TYPE	4-24
	■DEPARTMENT CODE	4-24
	■GROUP CODE	4-24
	■RESISTER CODE	4-24
	■COST PRICE	4-25
	■POP MESSAGE	4-25

4.11	System	4-26
	■SYSTEM	4-26
	■PLU	4-26
	■COMMODITY NAME	4-26
	■PRESET KEY	4-26
	■STORE ADDRESS	4-27
	■DATE	4-27
	■EXTRA MESSAGE 1	4-27
	■OPEN PLU	4-27
	■ITEM LIST	4-27
	■RS232C COMMUNICATION	4-28
	■COUPON MESSAGE	4-28
	■EXTRA MESSAGE2	4-28
	■EXTRA MESSAGE3	4-28
	■TCP/IP COMMUNICATION	4-28
	■OPERATOR NAME	4-29
	■TITLE MESSAGE	4-29
	■ADVERTISEMENT MESSAGE	4-29
	■DEPARTMENT	4-29
	■GROUP	4-29
	■CAMPAIGN ITEM	4-30
4.12	Ethernet Setup	4-31
	■IP ADDRESS SETUP	4-31
	■GATEWAY ADDRESS SETUP	4-32
	■SUBNET MASK SETUP	4-33
	■SERVER ADDRESS SETUP	4-34
	■LOG-IN NAME ADDRESS SETUP	4-35
	■PASSWORD SETUP	4-35
	■MAC ADDRESS SETUP	4-36
	■DHCP SETUP	4-37
	■NETWORK STATUS	4-38
4.13	System Timer	4-39
4.14	Password Setup	4-40
	■REGISTRATION	4-40
	■TOTAL	4-40
	■SUBTRACTION	4-41
	■SETUP	4-41
	■PASSWORD CHANGE	4-41
4.15	Machine Number Setup	4-42

CHAPTER 5 ELECTRICITY COMPOSITION

5.1	Block wiring diagram	5-1
5.2	Main Board [PK-950B]	5-2
5.3	Connector Specifications	5-3
5.4	PK-229A (A/D board)	5-7
5.5	Lithium Battery	5-7
5.6	Power Unit (PB-LSF150-S)	5-8
5.7	PK-232 (TCP/IP)	5-9
5.8	PK-236A (Span switch)	5-10
5.9	P-862A (Key board)	5-10

CHAPTER 6 TROUBLESHOOTING

6.1 Error List 6-1
6.2 Symptom, Cause, And Measures 6-4

CHAPTER 7 PARTS REPLACEMENT

7.1 Removing the covers 7-1
 ■Removing the main unit cover 7-1
 ■Removing the controller unit rear cover 7-1
 ■Detach the weigh platter 7-2
 ■Detaching the platter holder 7-2
7.2 Detaching Internal Parts 7-3
 ■Detaching the keyboard relay board (P-862A) 7-3
 ■Detaching the key sheet 7-3
 ■Detaching the display 7-3
 ■Detaching the power supply 7-4
 ■Detaching the span switch (PK-236A) 7-4
 ■Detaching the PK-232 (TCP/IP) 7-4
 ■4-corner limit adjustment 7-5
 ■Detaching the PK-229A (A/D board) 7-5
 ■Detaching the PK-950B (Main board) 7-6
 ■Detaching the thermal head 7-7
 ■Cleaning the thermal head 7-8
 ■Adjusting the belt tension 7-8
 ■Cleaning the label sensor/peel sensor 7-8
7.3 Periodical Replacement Parts 7-9

CHAPTER 1 OVERVIEW

1.1 Appearance and Name of Each Part

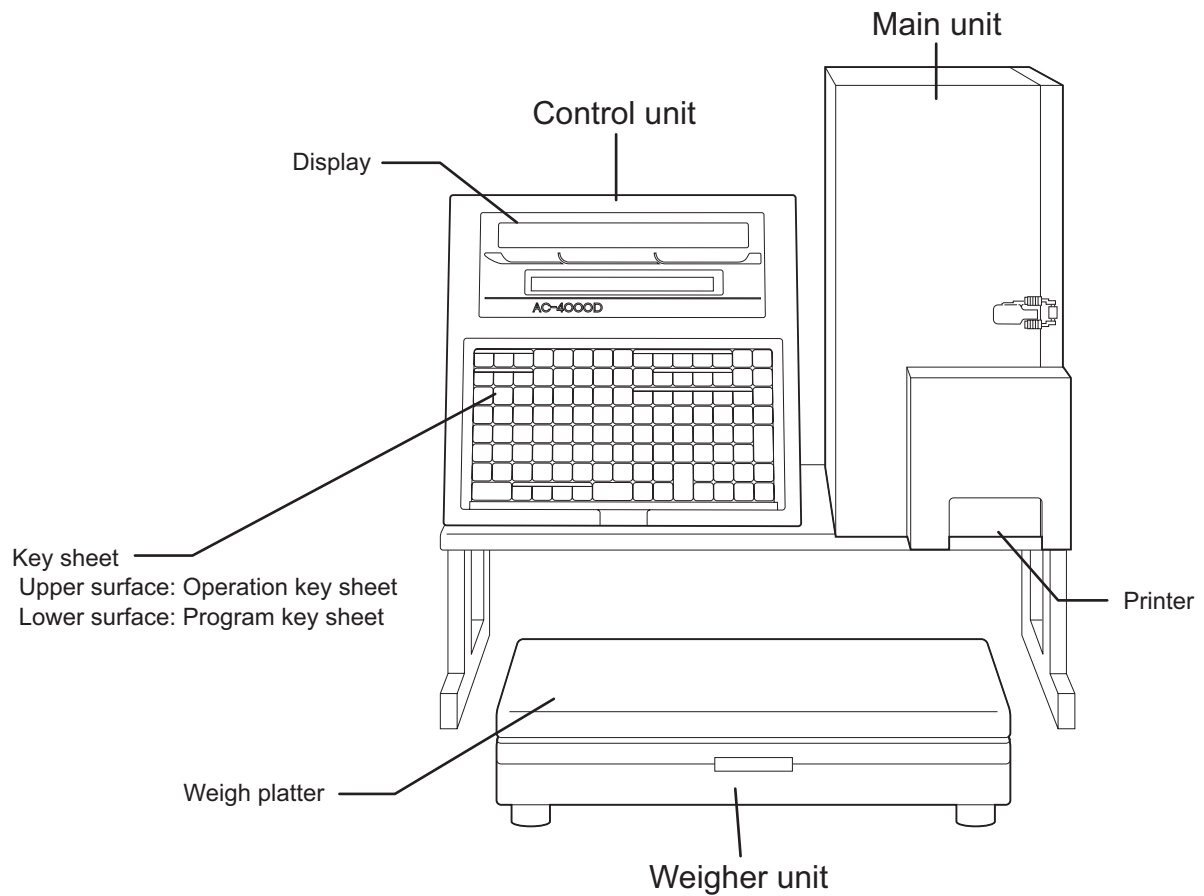

1.2 Display

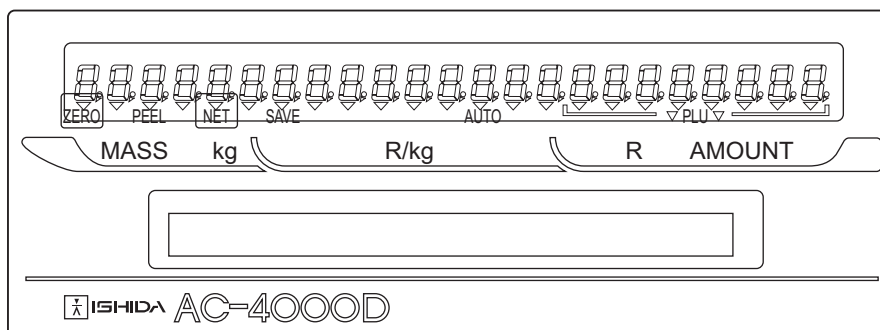

1.3 Key Sheet

MESSAGE			EDIT FUNCTIONS										ZERO	HELP	
EXTRA TEXT	COUPON TEXT	ADV MSG	PF KEYS	DATE TIME	PLU LIST	STORE NAME	BAR CODE	BS	CHAR DELETE	←	↑	→			
REPORT NAMES			EDIT FUNCTIONS										RESET	MODE	
DEPT.	GROUP	OPERATOR	Ë	œ	ï	é	è	ü	LINE DELETE	INSERT	↓	END			
CHARACTER STYLE										COPY					
Ä	Ö	Ñ	Ç	À	Æ	Ø	β	NORMAL	ITALIC	UNDER LINE	REVERSE	BOLD	SIZE		
!	,	"	#	\$	%	&	~	<	>	=	+	PRICE CHANGE	ADV PRICE	EDIT PLU	PAPER FEED
Q	W	E	R	T	Y	U	I	O	P	?	7	8	9	●	
A	S	D	F	G	H	J	K	L	;	@	4	5	6	PRINT	
LOWER CASE	Z	X	C	V	B	N	M	,	.	●	1	2	3	PLU	
●	SHIFT	GRAND TOTAL	SALES	DAILY SALES	REPORTS	●	SPACE	EDIT	*	NEW LINE	0	CLR	TARE	ENTER	

1.4 Printer

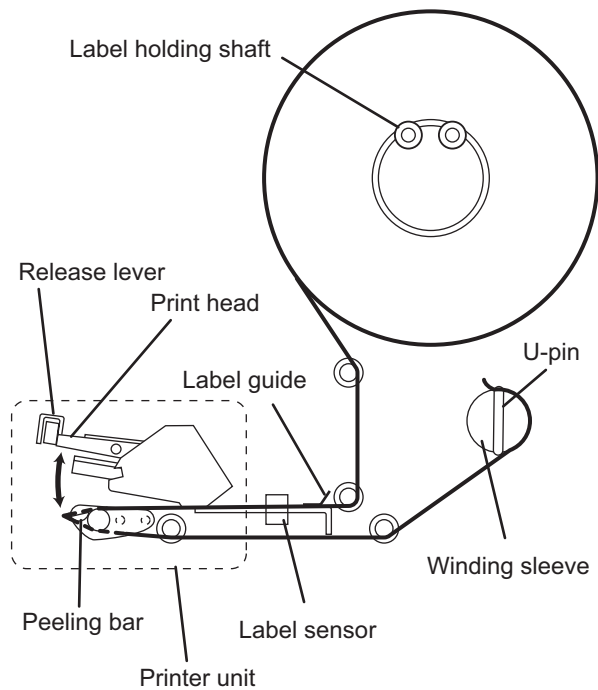

1.5 Main Specifications

Item	Content
Weighing capacity	6kg, 15kg or 30lb
Minimum graduation	2g, 5g or 0.01 lb
Weighing accuracy	1/3000 (Dual interval)
Load cell	HBM made
Size	Main unit: 200(W) x 370(D) x 400(H) mm Control unit: 320(W) x 40(D) x 322(H) mm Weigher unit: 400(W) x 254(D) x 95(H) mm
Weigh platter material and size	SUS430...400(W) x 250(D) mm
Printer	Backing paper width...Max. 67mm, Label width...38 to 64mm, Effective print width...Max. 60mm, Print speed...80mm/second
Label roll size	Inner diameter: 76mm
Label length	30 to 240mm
Sensor	Peel sensor
Key	Membrane switch (120 keys)
Display	Fluorescent display tube: 23 digits Character height: 10.1mm, 256 x 16 dots
Operating temperature	-5 to 40°C
Operating humidity	Main body: Max. 95% (40°C), No condensation Printer: Max. 80% (40°C), No condensation
Power supply	Varies depending on where the machine is used. (Specified on the rating plate)
Power consumption	Stand-by: Approx. 40W Operating: Approx. 100W
Weight	Main unit: 10.5kg / Control unit: 3kg / Weigher unit: 6kg
Memory capacity	Standard: 1MB Factory option: 2MB
Interface	RS232C (D-sub 9 pin)
TCP/IP	10 baseT
LAN cable	Direct connection: Crossing cable When using Hub: Straight cable
SRAM	1M bytes (1,024k bytes) SRAM mapping 1. Fixed data: Approx. 19k bytes Approx. 1k bytes for fixed data year, print speed, and print density, etc., and the remainder is the reserves. 2. Logo data: Approx. 56k bytes 3. SRAM file: Approx. 949k bytes 949k bytes for registration 9k bytes for file creation (940k bytes available after RAM is cleared) PLU, Store name/address, Extra message 1/2/3, Coupon, Preset, Label format, Field title, and Operator

1.6 Layout of components

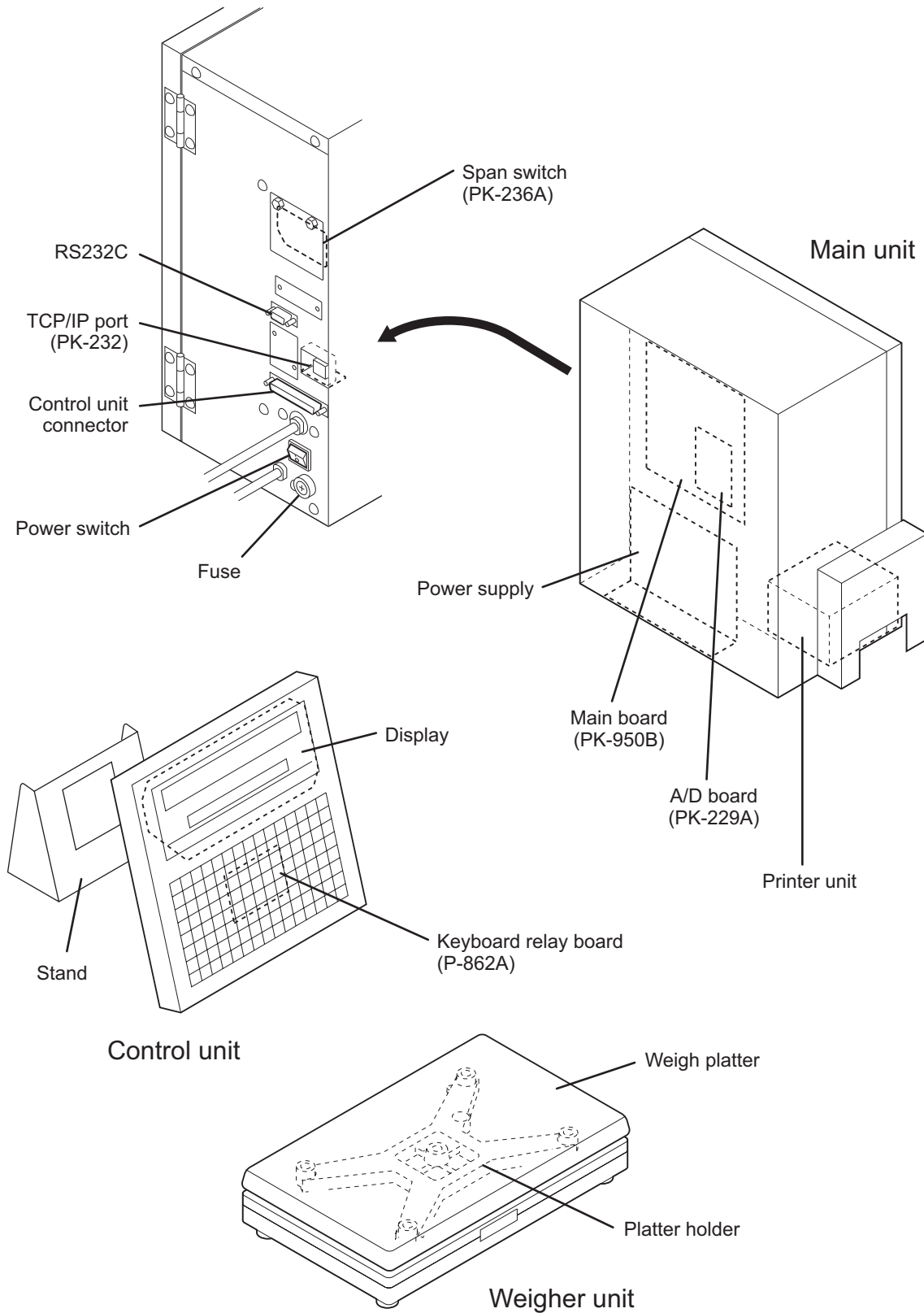

CHAPTER 2 INSTALLATION

2.1 Packed Goods

Open the packing case and check whether there are all the packed goods (machine and attachments) and if there are any damaged parts.

1. Operation manual, Keysheet
2. Control unit
3. Screws
4. Thermal head cleaner
5. Stand
6. Weigher unit
7. Main unit

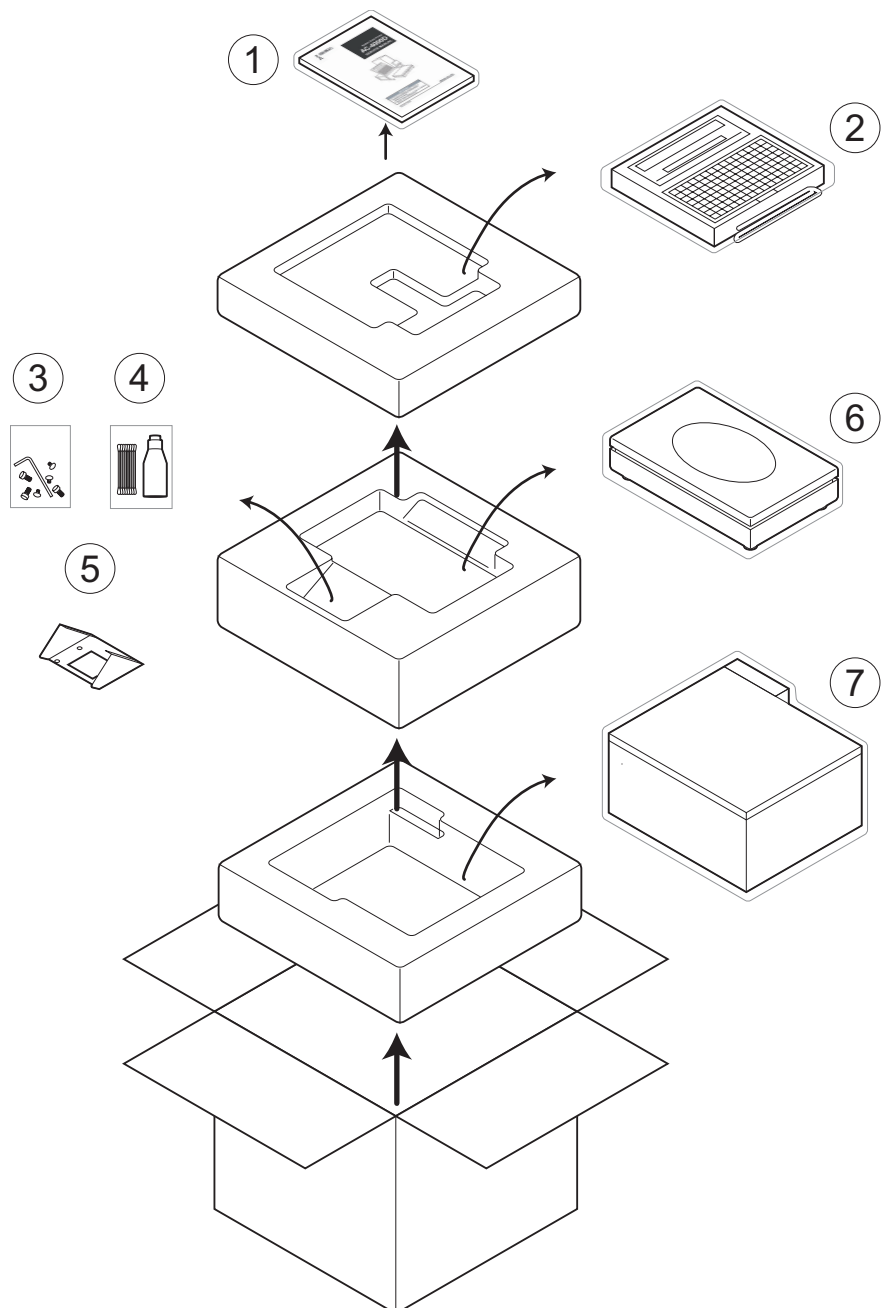

2.2 Installation Environment

- Install the machine on the stable and horizontal place.
- Install the machine in the place where the liquid such as water does not splash.
- Avoid the place where direct sunshine strikes for a long time.
- Install the machine in the place where the influence such as the winds is not received.
- Secure the installation space enough.

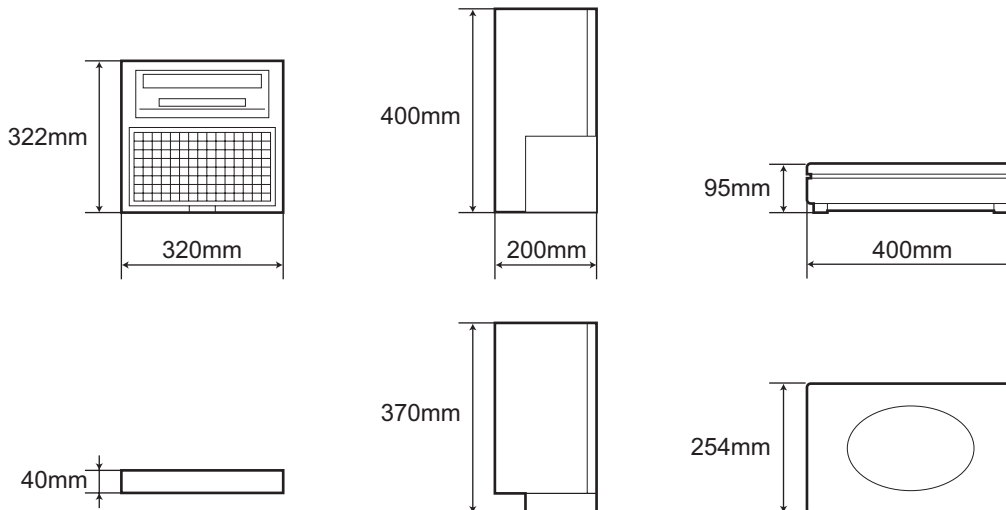

2.3 Installing the stand

- Install the stand on the rear of the control unit with the four screws.

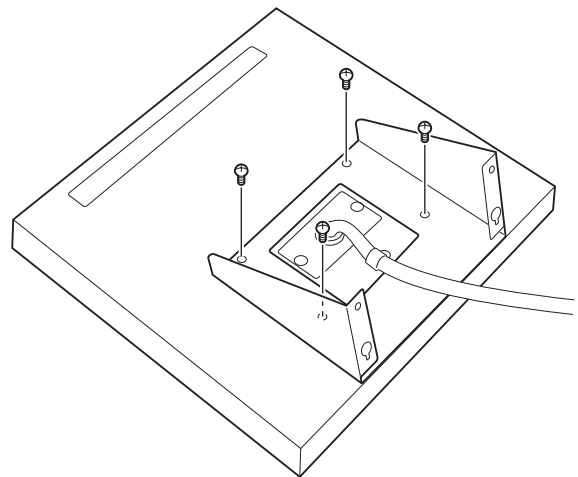

2.4 Connecting the cable

- Insert the control unit cable connector into the port at the rear of the main unit and secure it.
- Insert the weigher cable connector of the main unit into the port of the weigher unit.

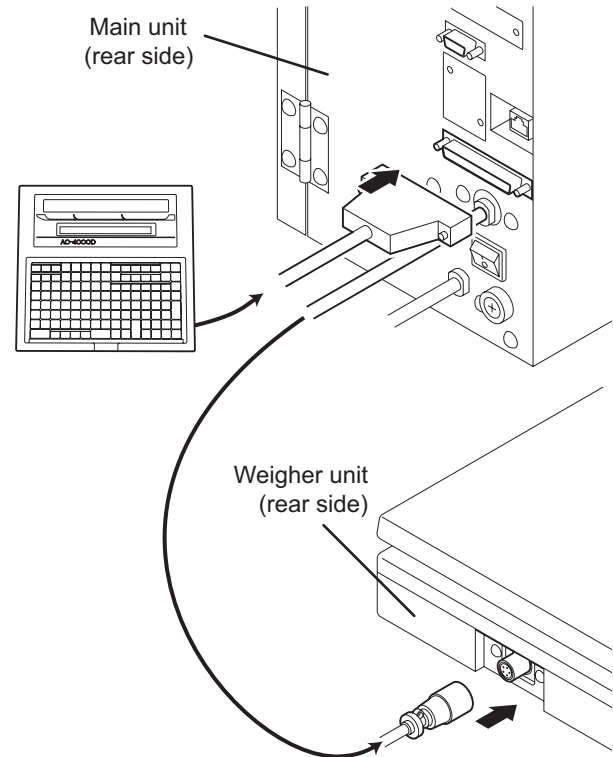

2.5 Label Loading

- 1 Open the side and printer covers of the main unit.

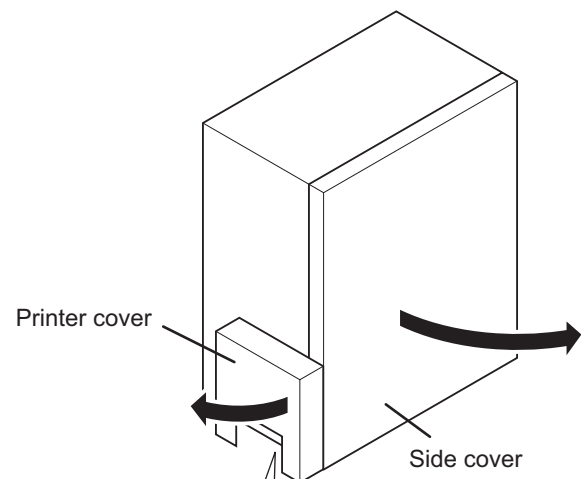

- 2 Pull the release lever to raise the print head.

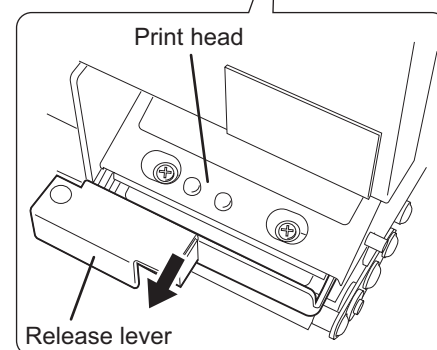

3 Remove labels from first 30 cm (12 inches) of backing paper.

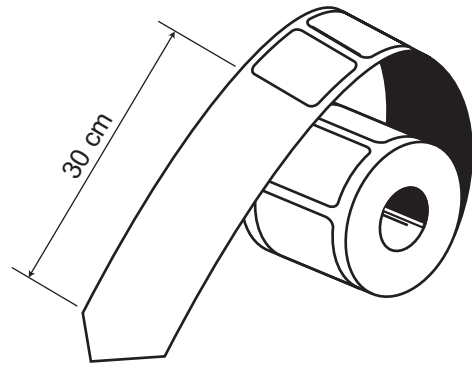

4 Slide a new label roll onto the label holding shaft, and pass the labels through the label sensor and the printer unit as shown on the right.

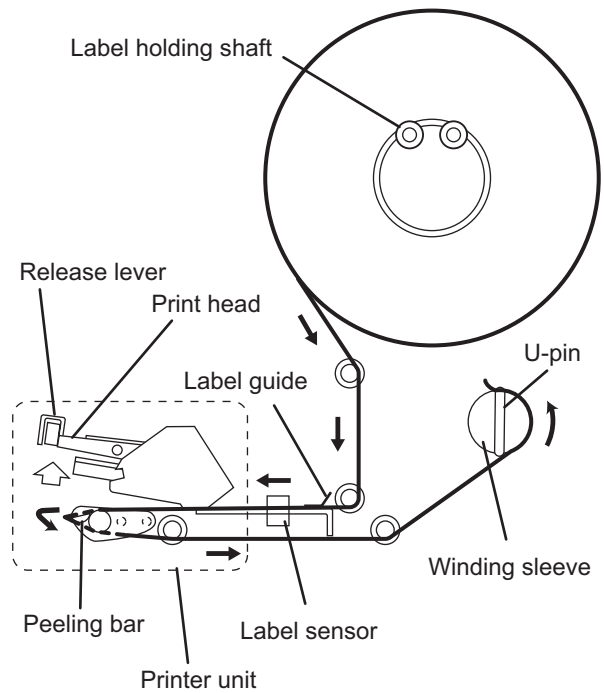

5 Secure the end of the backing paper to the winding sleeve with a U-pin.

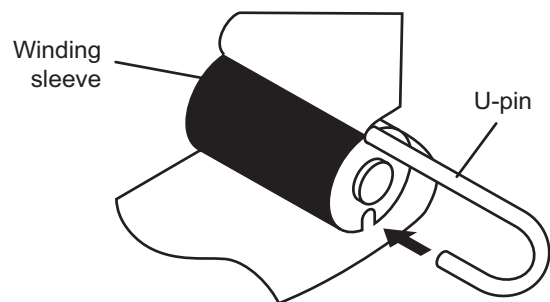

6 Depress the print head until it locks securely.

7 Close the side and printer covers.

2.6 Power Cable Connection

- Insert the power cable plug into the power outlet.

Note: The power outlet shape varies according to customers.

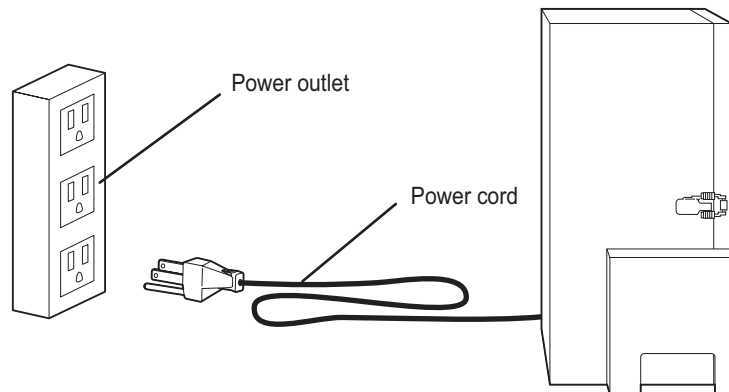

Ensure to establish a ground at the customer side.
110 V /220 V input power supply can be used. However, set the jumper lead to the required voltage display side before the power is turned ON.

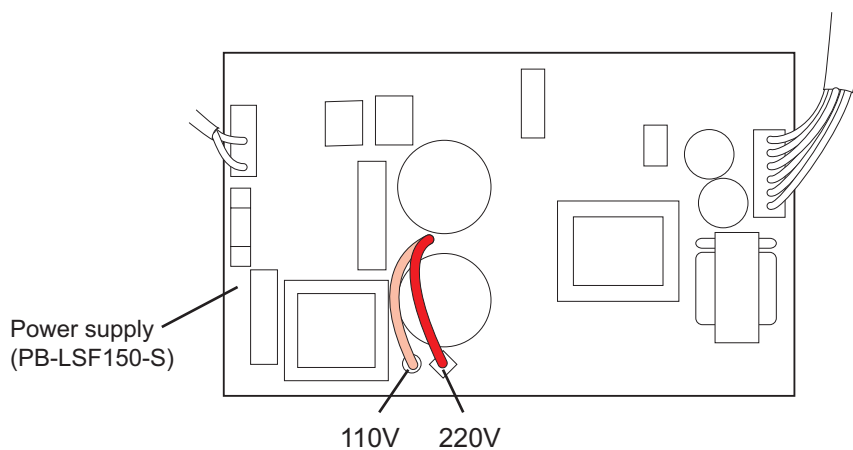

2.7 Power Switch “ON”

- Turn on the power switch located at the rear side of main unit.

Note: Push the “O” side of the switch to urn off the power.

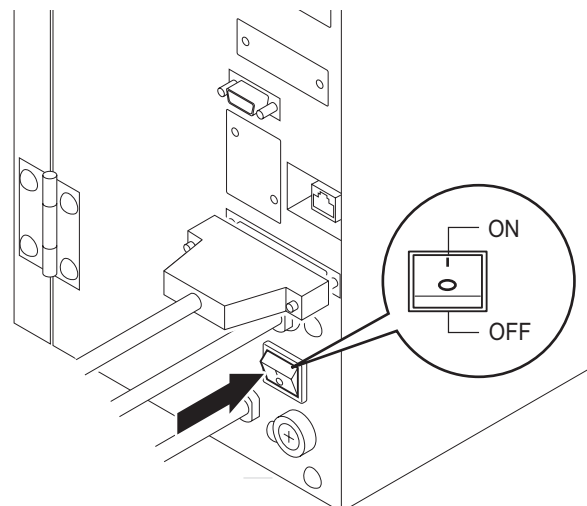

2.8 Customer's Specification Setup (Initialization, Setup, and Registration)

Set up required specifications according to the following sequence.

Test mode (Refer to Chapter 3 "Test Mode")

1. Hardware test	P.3-2
2. RAM clear	P.3-7
3. Printer head	P.3-11
4. Label sensor check	P.3-13
5. Total memory	P.3-14
6. ROM switch	P.3-15
7. Peel sensor check	P.3-17
8. Machine type check	P.3-18

Setup mode (Refer to Chapter 4 "Setup Mode")

1. Label format	P.4-3
2. POS code	P.4-10
3. Item code	P.4-13
4. Default data	P.4-14
5. Total mode select	P.4-16
6. Open price	P.4-17
7. PLU selection	P.4-18
8. System	P.4-26
9. Ethernet setup	P.4-31
10. System timer	P.4-39
11. Password setup	P.4-40
12. Machine number setup	P.4-42

2.9 Normal Mode Display

1. All segments blink three times when the power is turned on.



2. Then, the initial display appears.

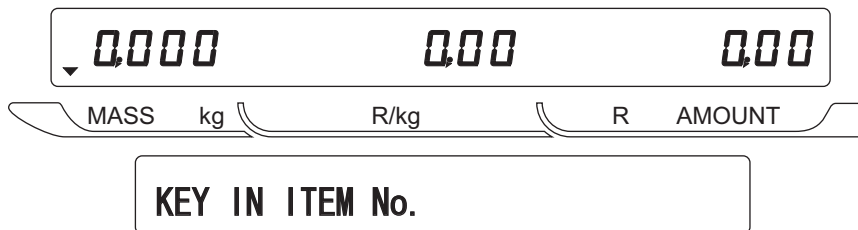

3. When calling up "Fixed price item" or "Weighing item".

■ Weighing item

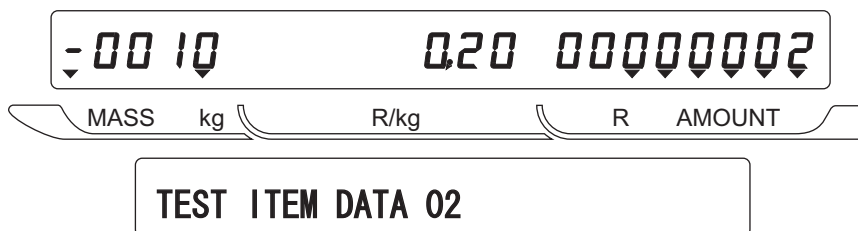

■ Fixed price item

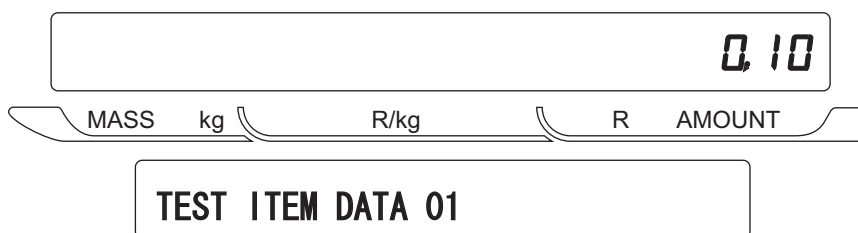

2.10 Label Batch Print Mode

- The following display appears when printing batches of labels.
- The label batch printing is a function which prints the item data and the number of labels registered in advance a for fixed price items.

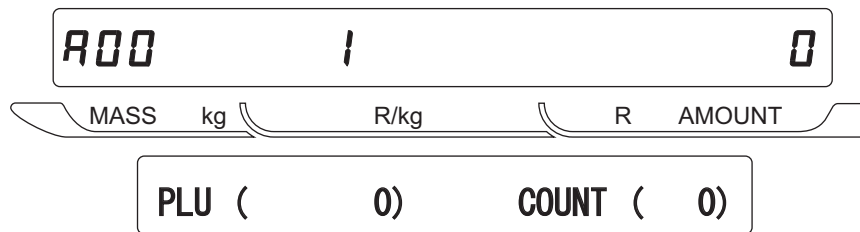

- Maximum number of specified items: 99 commodities
- Maximum number of specified labels: 9,999 labels
- Preset key number: 19 presets

Note: Registered data is cleared when the power is turned OFF.

2.10.1 Basic operation

- Assign the BATCH PRINT key (Preset key number: 19) to any one of preset keys.
P04-01 screen menu 19 + [→] + 0 + Preset key

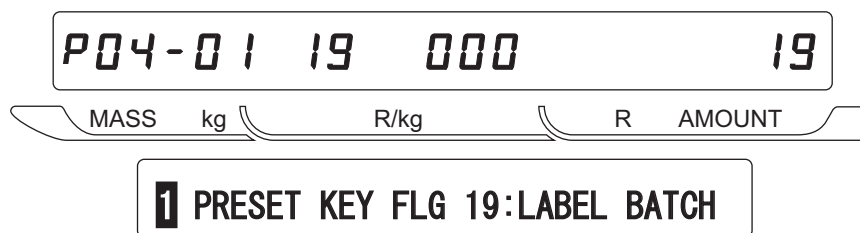

- Press the LABEL BATCH key to enter the label batch print mode.
This function is available before an item is called up.
1. Call up a fixed price item.
Key in an item number, then press the PLU key.
Note: An error buzzer sounds when other item is called than fixed price item.
 2. Specify the number of labels to be printed.
Key in the number of labels, then press the ENTER key.
Note: An error buzzer sounds when the limited number of labels (9,999 labels) exceeds.
 3. Repeat above steps 1. and 2. to specify the number of labels for other items.
Note: An error buzzer sounds when exceeding the maximum number of specified items (99 items).
 4. Press the PRINT key to start printing. Then, printing starts in the sequence from the most recently registered item.
Note: An error buzzer sounds when there is no item registered for label batch printing.
 5. The machine returns to the normal mode after all registered items are printed.

2.10.2 Additional functions

1. End of the label batch print mode
The machine returns to the normal mode when the MODE key is pressed.
The registered data is preserved as it is if there are any registered items.
2. Printing preserved data
If there is any preserved print data, printing starts by pressing the PRINT key.
Note: An error buzzer sounds if there is no registered data.
3. Deleting label batch print data
The label batch print data is deleted while sounding an OK buzzer by pressing the ZERO key twice.
4. Stop of label batch print operation
Label batch print stops by pressing the PRINT key while printing a print reservation data.
However, the remaining label batch print items are not deleted.
(If printing stops when five labels have been issued for an item specified to issue 10 labels, the remaining 5 labels are preserved.)
5. Addition of label batch print data to the preserved data
The label batch print data is added to the preserved data.
(When there are "40 preserved items", "59 items" can be added.)

2.10.3 Label batch printing on continuous paper

The same operation is applied for continuous paper which is set in the B01-01-05 menu.
Refer to 4-4 in Chapter 4.



2.11 Scroll Message Display

- A function to display the registered scroll message. When an item has not been called up, it starts after five seconds have passed.



- Display method registration function
(0: No display 1: High-speed scroll 2: Normal scroll 3: Low-speed scroll
4: High-speed blinking 5: Normal blinking 6: Low-speed blinking)
- Day of the week registration function
(0: Every day 1: Sunday 2: Monday 3: Tuesday 4: Wednesday 5: Thursday 6: Friday 7: Saturday)
- Display time registration function (Start/stop)

[Example] 09:00 to 13:00
Enter "0913" and press the ENTER key.

- Maximum number of scroll messages: 9 messages (1 to 9)
- Maximum number of characters: 96 characters (one byte English code)

2.12 Campaign Function

- Registered campaign items start to be sold at the registered campaign price when the time reaches registered campaign time.

- Maximum number of campaign: 20
- Maximum number of items for each campaign: 100
- Discount method
(0: Unit price 1: Special price 2: Amount discount 3: Percent discount 4: Special unit price)

- Campaign 1 becomes top priority for items registered during the overlapping time.
- Priority is given from Campaign 1, 2, and 3 to the last 20 if the same item is registered. That is, priority is given to the campaign 1 even if the same item is registered in campaign 1 and 2 during the overlapping time.
- Registration of the same item is not supported in one campaign.
- An error message appears when a label is issued with a registered price in the campaign greater than the weighing price.

CHAPTER 3 TEST MODE

3.1 Test Mode Menu List

■Hardware test

_____	a) A/D check	P. 3-2
_____	b) Key check	P. 3-4
_____	c) Display check	P. 3-4
_____	d) RS232C check	P. 3-5
_____	e) Application program number	P. 3-5
_____	f) BIOS program number	P. 3-6

■RAM clear

_____	a) RAM clear	P. 3-7
_____	b) Setup clear	P. 3-8
_____	c) Test data set	P. 3-8
_____	d) Application copy	P. 3-9
_____	e) BIOS copy	P. 3-9

■Printer head

_____	a) Resistance	P. 3-11
_____	b) Print usage in km	P. 3-12
_____	c) Resistance value	P. 3-12

■Label sensor check

_____	• Level sensor	P. 3-13
-------	----------------------	---------

■Total memory

_____	• Total Memory	P. 3-14
-------	----------------------	---------

■ROM switch

_____	• ROM switch	P. 3-15
_____	• ROM switch number	P. 3-15

■Peel sensor check

_____	• Peel sensor check	P. 3-17
_____	• Peel sensor	P. 3-17

■Machine type check

_____	• Hardware selection	P. 3-18
-------	----------------------------	---------

3.2 Test Mode Start

Reset the main power or press the RESET key, then immediately press and keep pressing any key other than the RESET key for a while until a buzzer sounds, the following test mode menu screen will appear by releasing the key.

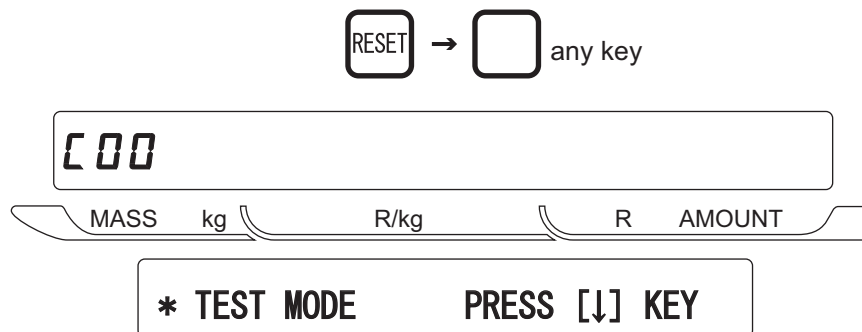

3.3 Hardware Test

■HARDWARE TEST

To select a desired menu, press the key to increment a menu, or enter a menu number followed by pressing the [↓] key.

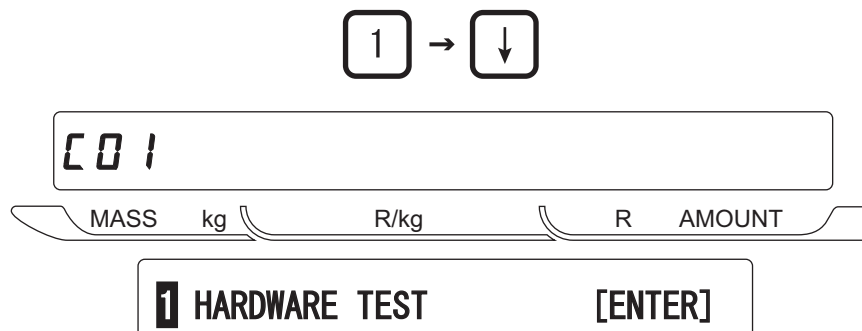

■A/D CHECK [Scale zero point/span check and adjustment]

- In the [C01] display, press the ENTER key to select the A/D CHECK menu. (It will take a few seconds until the A/D board is initialized.)

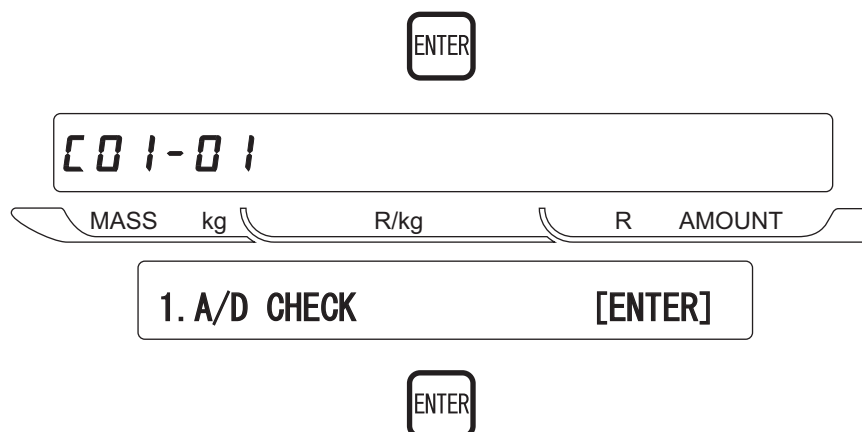

- Firstly, the A/D original data appears.

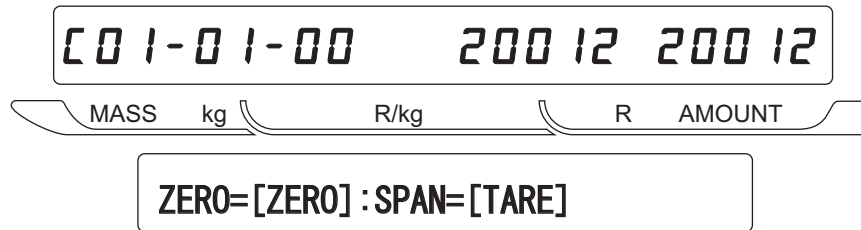

- Pressing the ZERO key changes to the calibrated data of “20000” counts and “0”. (“20000” counts is a data output from the A/D unit, and “0” denotes that “20000” counts are regarded as zero point.)

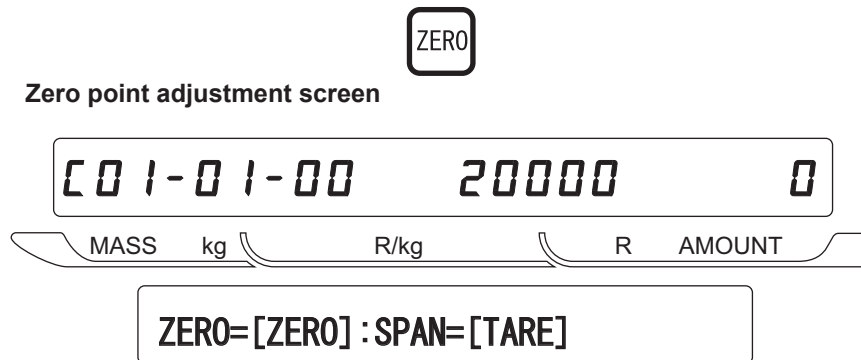

- In “C01-01-00” menu and after a zero point adjustment, put the same weight as the maximum weighing capacity and press the TARE key to perform an auto-span.

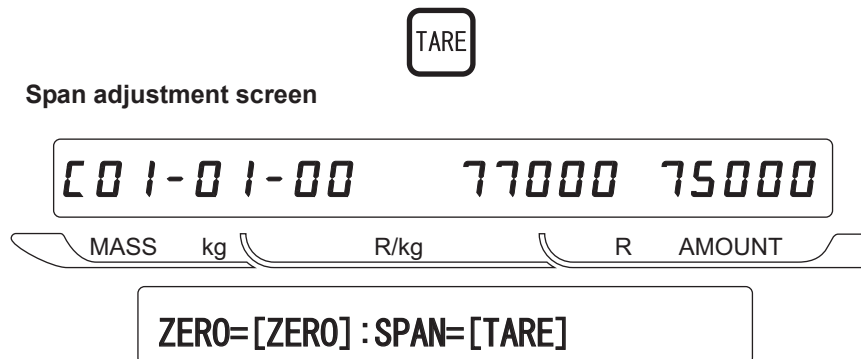

- After the span adjustment, finish to check the zero point and the weighing capacity value by repeating zero point and span adjustments.
- After completing the span adjustment, push the memory button on the board to store the adjustment value in E2ROM.
- When initializing E2ROM of the A/D circuit to the initial value, press the DEL key to initialize.
- When E2ROM storage completes, press the END key to return to the hardware test menu screen.

Note 1: Changed data is cleared at the end of this menu unless it is stored in E2ROM by pushing the memory button.

Note 2: The memory button is described in “Chapter 5”.

■KEY CHECK [Membrane key check mode]

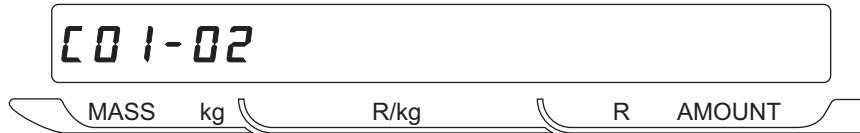

2. KEY CHECK [ENTER]



- The input membrane key data other than the RESET key is displayed.

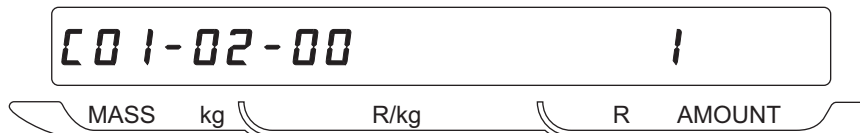

* KEY CHECK KEY DATA

- Press the RESET key to return to the hardware test menu screen.

■DISPLAY CHECK [Multiple tube display check mode]

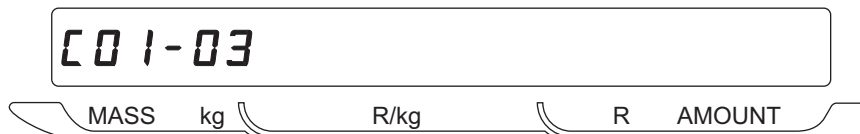

3. DISPLAY CHECK [ENTER]



- Each segment of all digits lights up.
(This display flashes in one second interval.)

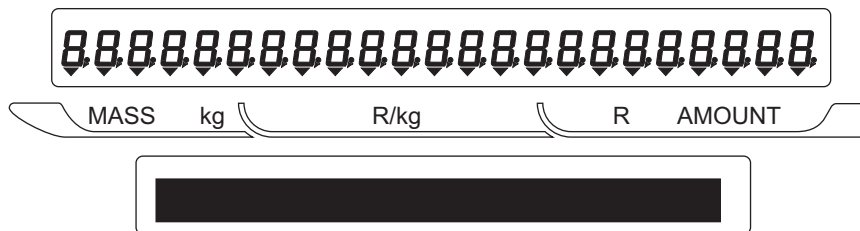

- Press the END key to return to the hardware test menu screen.

■RS232C CHECK [Driver/receiver test]

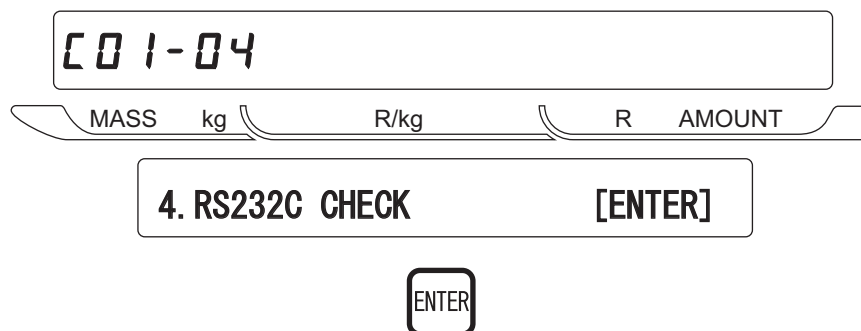

- Serial output port (RS232C) driver/receiver test menu screen



- Perform a loop back test to carry out the RS232C input test. Engage the TXD and RXD short-circuited connector with D-SUB 9, press the PRINT key to output test data, and judge by verifying received test data and sent data.
If the data matches, "PASS" is displayed and "OK" buzzer sounds.
"Error" is displayed and "NG" (No Good) buzzer sounds.
- Press the END key to return to the hardware test menu screen.

■APPLICATION PROGRAM No. [Program no. and version display check]

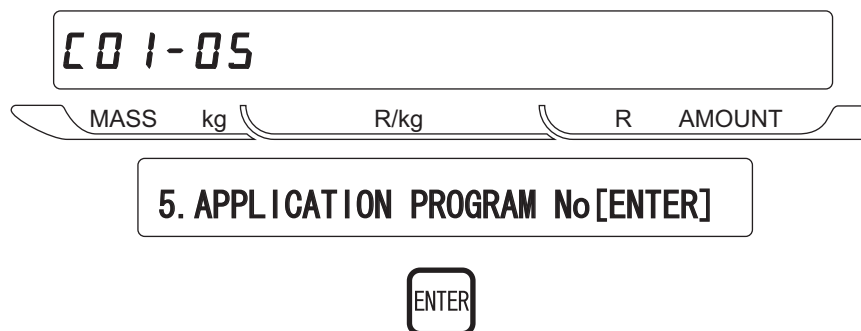

- The program number and version of the main program are displayed.

Note: The program number for the prototype is the development code "APLY".



- Press the END key to return to the hardware test menu screen.

■ BIOS PROGRAM No. [Program no. and version display check]

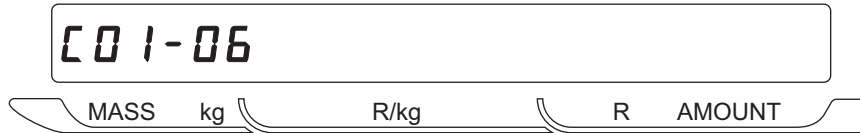

6. BIOS PROGRAM No. [ENTER]



- Program number and version of the BIOS program are displayed.

Note: The program number for the prototype is the development code "BOOT".

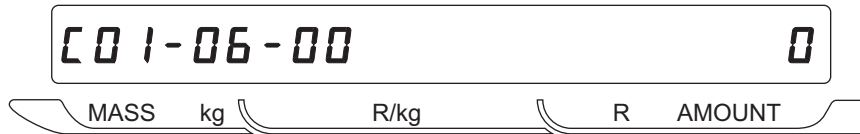

* PROGRAM No. :BIOS B0446A

- Press the END key to return to the hardware test menu screen.

3.4 RAM Clear

■RAM CLEAR

Press the [↓] key to increment a menu, or enter a menu number followed by pressing the [↓] key.

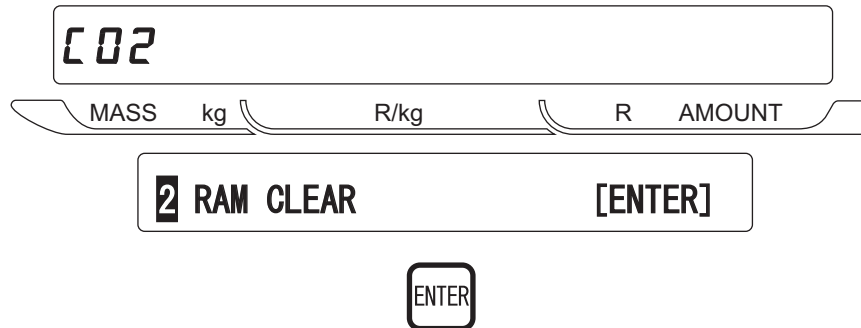

■SRAM CLEAR

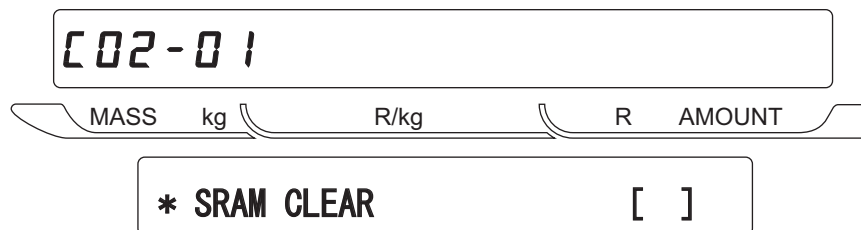

- This menu is used when clearing SRAM. When this menu is executed, all the SRAM data is cleared (initialization). SRAM clear is executed by pressing the ZERO key twice.

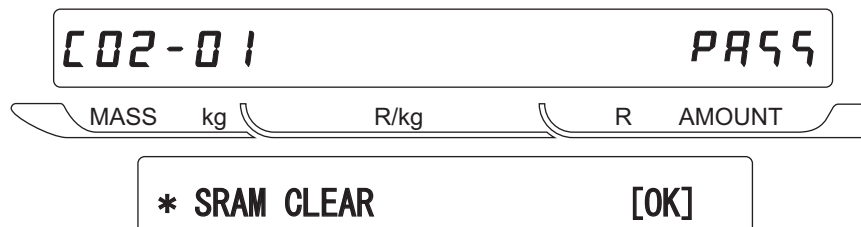

- When SRAM clear is complete, "PASS" is displayed and "OK" buzzer sounds.
- If an error is detected, "ERR" is displayed and "NG" (No Good) buzzer sounds.
- Press the END key to return to the test mode menu screen.

■SETUP CLEAR [E2ROM default]

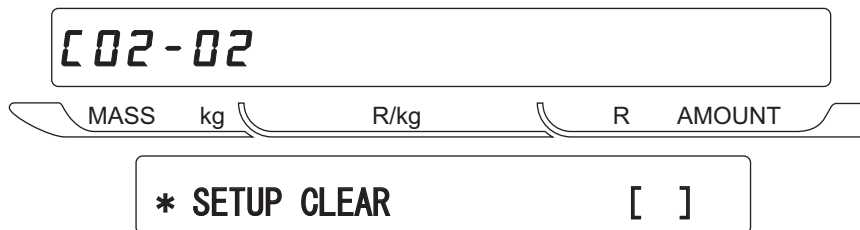

- This menu is used when initializing E2ROM to a default value. When this mode is executed, the content of the E2ROM switch is initialized to default. SRAM clear is executed by pressing the ZERO key twice.

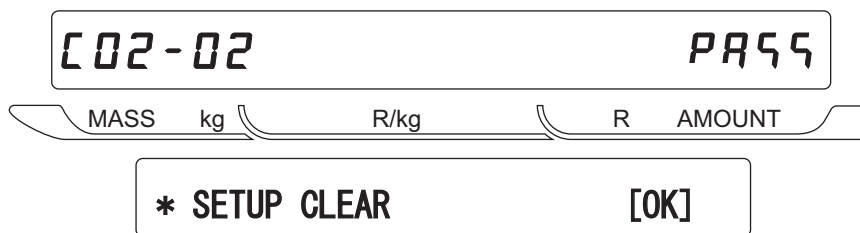

- When processing is complete, “PASS” is displayed and “OK” buzzer sounds.
- If an error is detected, “ERR” is displayed and “NG” (No Good) buzzer sounds.
- Press the END key to return to the test mode menu screen.

■TEST DATA SET

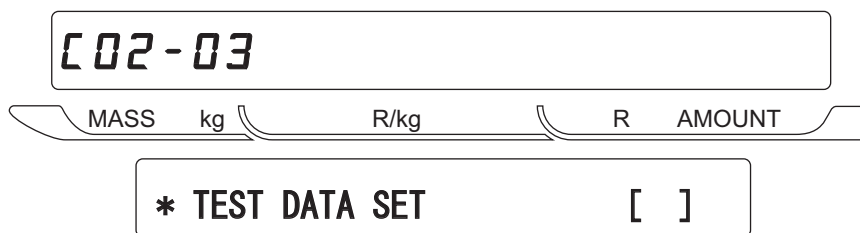

- This menu is used when setting up the machine for the first time (when there is no backup data).
- In this mode, execute a set of SRAM clear + E2ROM setup + Dummy data creation.
- The dummy data memorizes 10 PLU data and the store name/address.
- SRAM clear is executed by pressing the ZERO key twice.

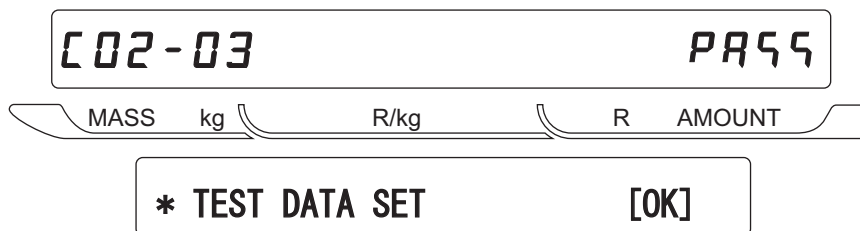

- When processing is complete, “PASS” is displayed and “OK” buzzer sounds.
- When an error is detected, “ERR” is displayed and “NG” (No Good) buzzer sounds.
- Press the END key to return to the test mode menu screen.

■APPLICATION COPY [Writing application]

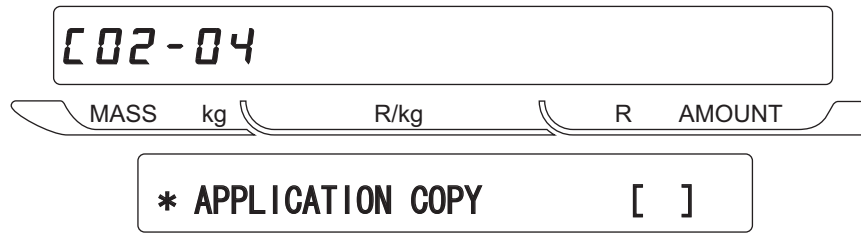

- Write the application part of flash ROM. [1M byte]

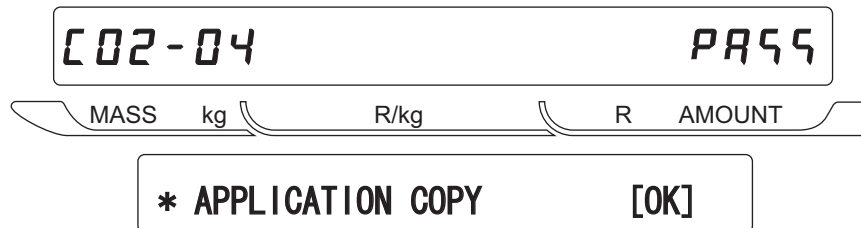

- When processing is complete, "PASS" is displayed and "OK" buzzer sounds.
- When an error is detected, "ERR" is displayed and "NG" (No Good) buzzer sounds.

■BIOS COPY [Writing boot program]

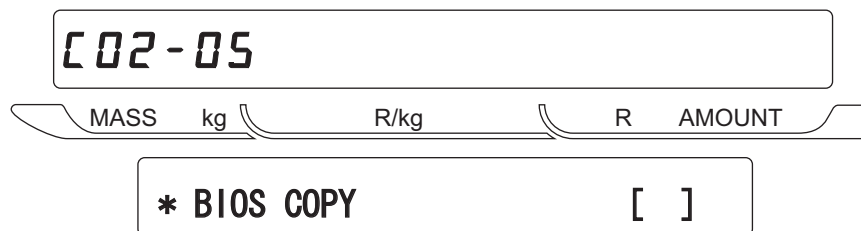

- Write the boot program part of flash ROM. [512k byte]

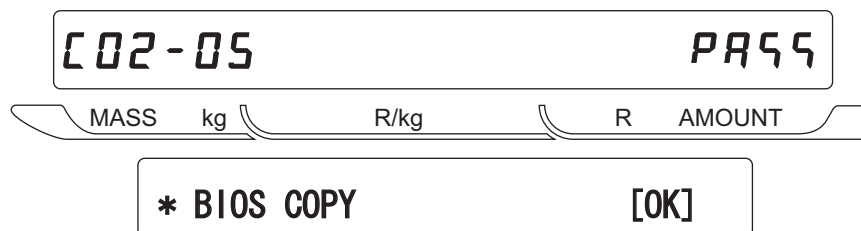

- When processing is complete, "PASS" is displayed and "OK" buzzer sounds.
- When an error is detected, "ERR" is displayed and "NG" (No Good) buzzer sounds.



BIOS COPY is not displayed in test mode.

■When using BIOS COPY

- If the machine locks, or the test mode entry is not possible, enter [APPLY COPY] → [BIOS COPY] and a transmission end message appears in [BIOS COPY], then press the ZERO key twice. [EXEC] + [PASS] is displayed.
- Standing up state after BIOS COPY is operated.
 - Internet Protocol address: 192. 168. 10. 1
 - Log-in: TEST
 - Password: USNET
- Perform “APPLI COPY” in the same operation as the above-mentioned.

■BOOT COPY starting procedure

1. Turn on the power switch while pushing the Memory button.

Note: Press the [↓] key. Then, “BOOT COPY” is displayed.

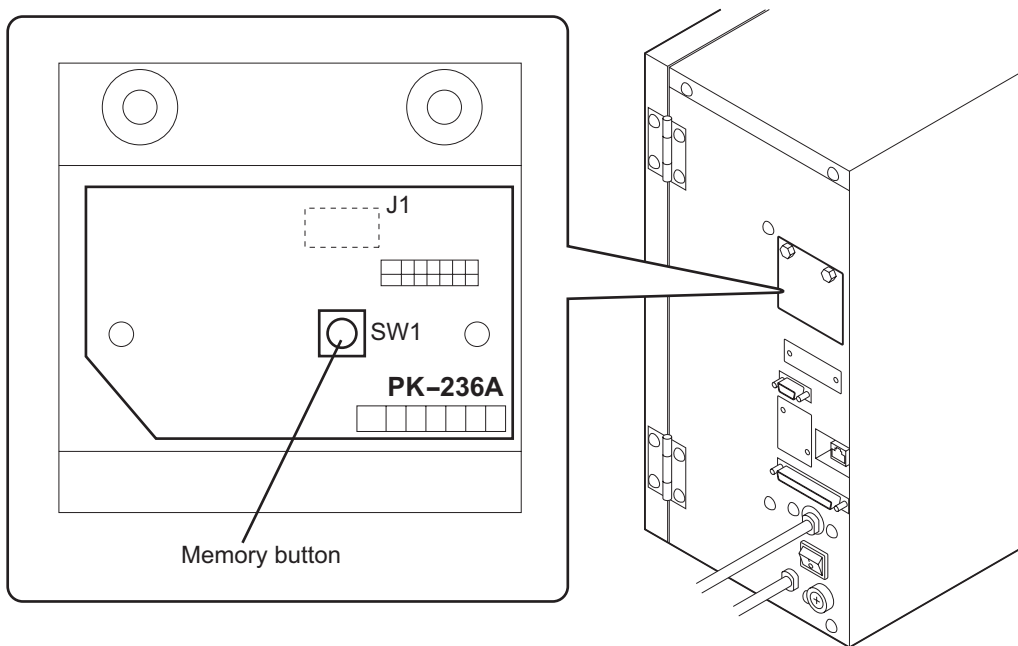

3.5 Printer Head

■PRINTER HEAD

Press the [↓] key to increment a menu, or enter a desired menu number followed by the [↓] key.

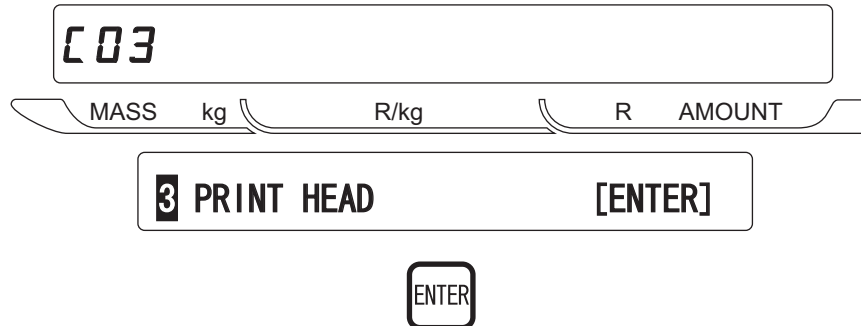

■RESISTANCE [Thermal head resistance value]

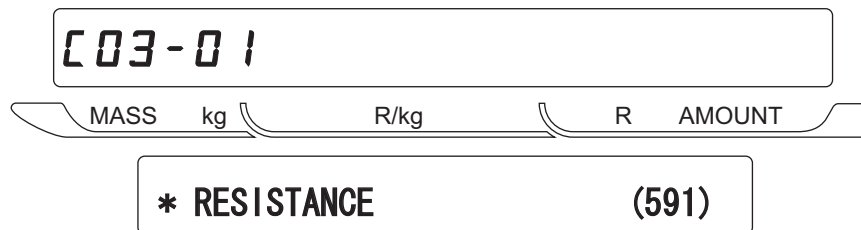

- Set a resistance value of the thermal head.
- Press the COPY key to read ID from the thermal head and set it automatically.



Or, enter a resistance value described on the head followed by the ENTER key.



- Stored data is memorized in E2ROM.

■PRINT USAGE IN km [Label travel distance display and clear]

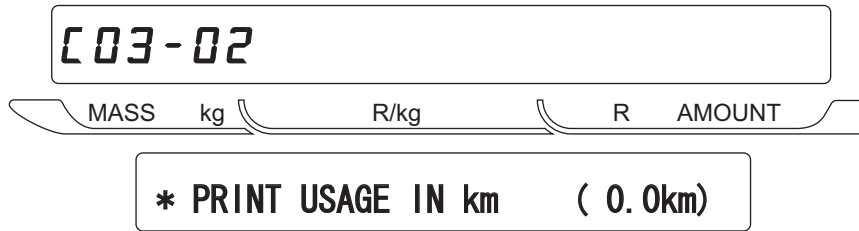

- This menu is used to check the print total travel distance. It is memorized in 100m unit (0.1km) and displayed.
- When resetting the travel distance:
Enter the password "495344", and press the SIZE key.



■RESISTANCE VALUE ADJUSTMENT [Print density adjustment]

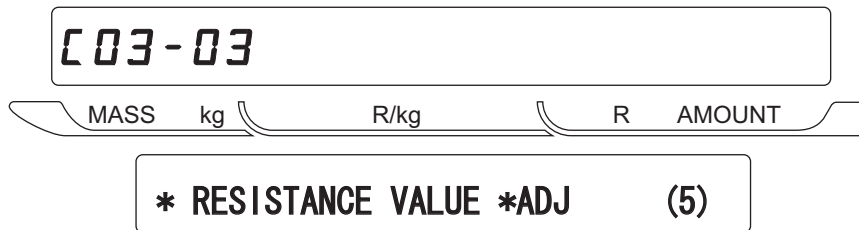

- Adjust the thermal head print density.
- Print density adjustment range: 1 (Thin) to 9 (Thick) [Default value = 5]
- Press the END key to return to the test mode menu screen.

3.6 Label Sensor Check

■ LABEL SENSOR CHECK

Press the [↓] key to increment a menu, or enter a desired menu number followed by the [↓] key.

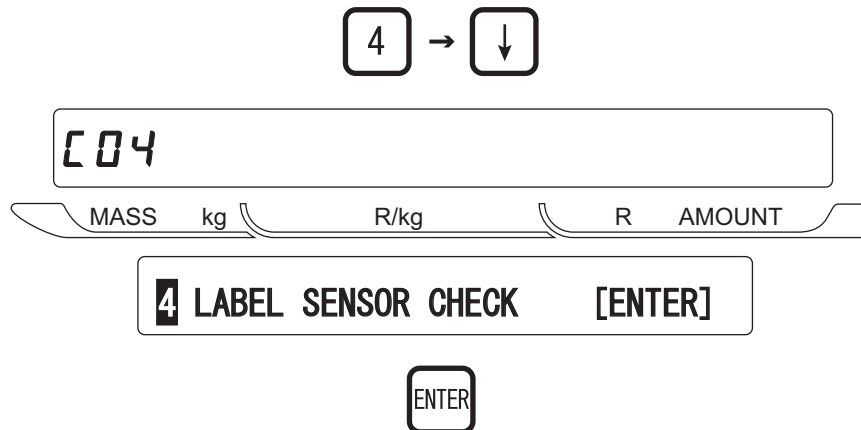

■ LABEL SENSOR [Output value adjustment]

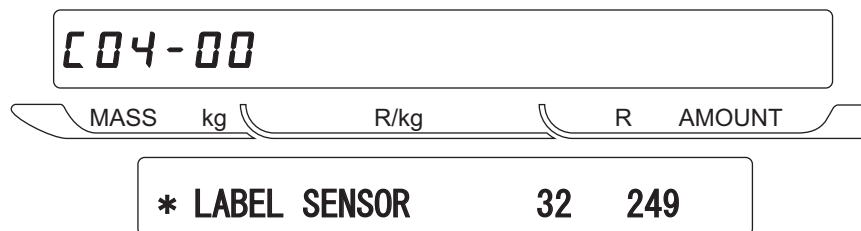

- [32] : Label sensor resistance value
- [33] : Label sensor output value (Label + Baking paper)
- [140] : Label sensor output value (Baking paper only)
- At adjustment: Label sensor output value deviation must be 50 or more between the case when a label exists and when no label exists.
- Output from the label sensor is displayed with a value after passing through the A/D converter.
- Adjustment value range: 0 to 255
- Adjustment method: Adjust the label sensor volume in digital form. Key in "0 to 255" and press the ENTER key to store.
- Press the END key to return to the test mode menu screen.

3.7 Total Memory

■TOTAL MEMORY

Press the [↓] key to increment a menu, or enter a desired menu number followed by the [↓] key.

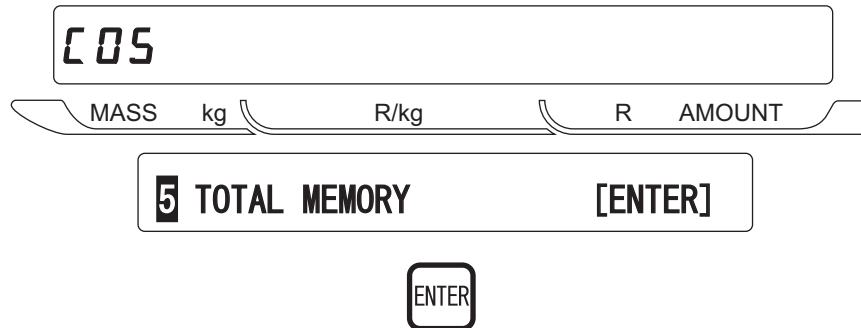

■MEMORY [Memory usage status]

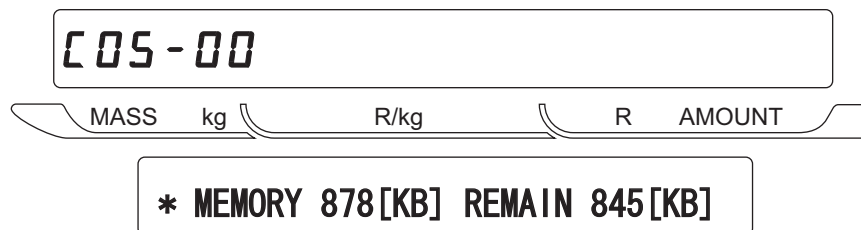

- A total memory and a free memory are displayed.
- A free memory is not necessarily corresponding to the remaining amount which can be stored, because it indicates only the one that the block is completely free.
- Press the END key to return to the test mode menu screen.

3.8 ROM Switch

■ROM SWITCH

Press the [↓] key to increment a menu, or enter a desired menu number followed by the [↓] key.

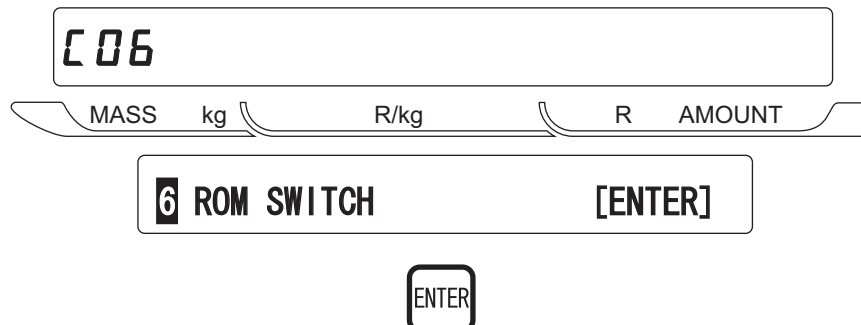

■ROM SWITCH No. [E2ROM switch change and check]

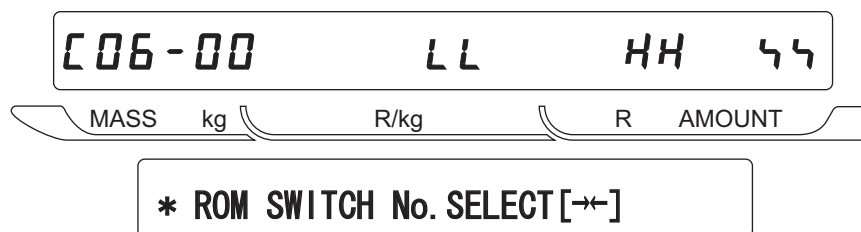

- Change or check the E2ROM switch in this menu.
- Multiple tube display "LL", "HH", "XX"
 "LL" indicates the E2ROM address.
 "HH" indicates the E2ROM address data.
 "XX" monitors the input data.
- To specify an address, use the arrow keys.
- To change a data, enter hexadecimal numerics by using the alphabet of [A to F] and numerics of [0 to 9].
- Press the END key to return to the test mode menu screen.

■ROM SWITCH No.

Note: "ROM SWITCH" items and default value vary depending on a country where the machine is used.

- Value in () indicates the default value.

[0]: Weight data zero suppression (4)

[1]: Price data zero suppression (3)

[2]: Unit price data zero suppression (3)

[3]: DC motor (41)

[4]: Fixed price item quantity addition "0": Real number "1": Fixed price item quantity

[5]: Price calculation rate "0": kg "1": 100g

[7]: Effective day calculation

When ROM SWITCH No.7 is "0", packed date is included. When ROM SWITCH No.7 is other numeric than "0", packed date is not included, therefore, add one day to the current effective day.

[8]: Time rounding calculation 0, 1 to 30 (0)

Function to increase the price based on the set minute at time now is set by standard.

(Minute/No. 8) * No. 8

[Example]

◇ Example: No. 8 = 1 min.

1 → 1 min., 2 → 2 min., 59 → 59 min.

◇ Example: No. 8 = 2 min.

1 → 0 min., 2 → 2 min., 3 → 2 min., 4 → 4 min., 5 → 4 min., 58 → 58 min., 59 → 58 min.

◇ Example: No. 8 = 3 min.

1 → 0 min., 2 → 0 min., 3 → 3 min., 4 → 3 min., 5 → 3 min., 6 → 6 min., 57 → 57 min.
58 → 57 min., 59 → 57 min.

⋮

◇ Example: No. 8 = 30 min.

1 → 0 min., 2 → 0 min., 3 → 0 min., 4 → 0 min., 5 → 0 min., 6 → 0 min.

29 → 0 min., 30 → 30 min., 31 → 30 min., 59 → 30 min.

[9]: Subtotal label item name mode

0 : "sub total" is printed.

1: Item name is printed when an item is called.

[10]: Reset key 0: Enable 1: Disable (0)

[11]: Automatic clear after totals are sent out

0: Not cleared (default) 1: Clear

[15]: Price calculation fraction processing (0)

0: 3rd decimal digit round-down 1: 3rd decimal digit round off

2: 2nd decimal digit round-down 3: 2nd decimal digit round off

[16] ITF BARCODE check digit calculation processing (0)

0: 3131. from the right 1: 1313. from the right

[17]: Head fault check (0)

0: Not available 1: Available (Set "0" for ASTRA XT)

[18]: Head fault check timing (0)

0: When calling 1: When issuing (no provision) ff: Only when changing to normal mode

[19]: Head check type (0)

0: Always at the head fault 1: When the number of head fault increases.

3.9 Peel Sensor Check

■PEEL SENSOR CHECK

Press the [↓] key to increment a menu, or enter a desired menu number followed by the [↓] key.

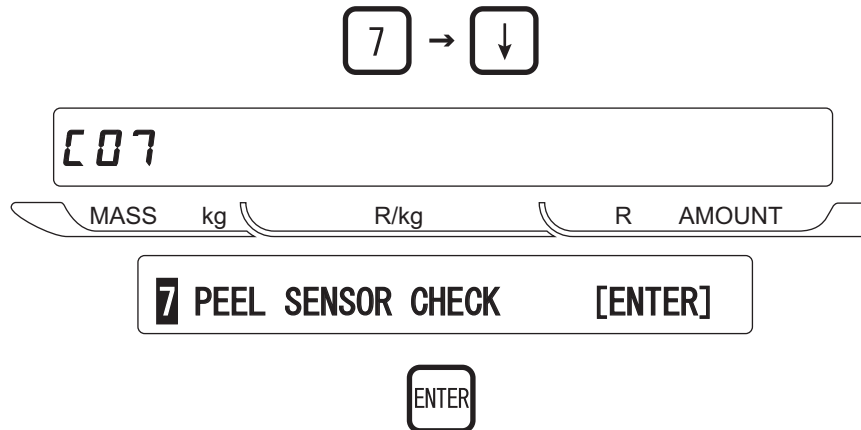

■PEEL SENSOR [Output value is checked]

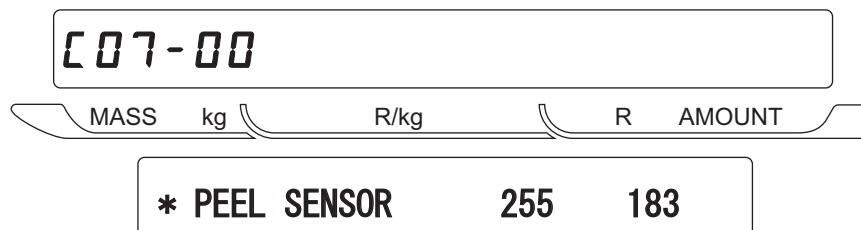

- Sensor value display
 [255]: Peel sensor resistance [186]: Peel sensor output value (Label + Backing paper)
 [255]: Peel sensor resistance [0] : Peel sensor output value (Backing paper only)
- Output from the peel sensor is displayed with a value after passing through the A/D converter.
- Setting range: 0 t o 255
- Input method: Key in 0 to 255, and press the ENTER key to store.
- Press the END key to return to the test mode menu screen.

3.10 Machine Type Check

■MACHINE TYPE SET [Hardware selection by specifying the machine type flag]

Press the [↓] key to increment a menu, or enter the desired menu number followed by the [↓] key.

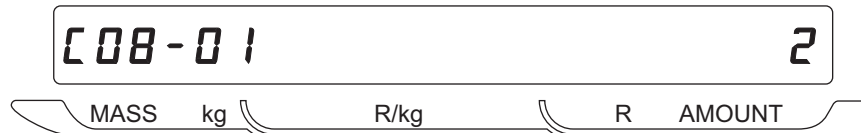
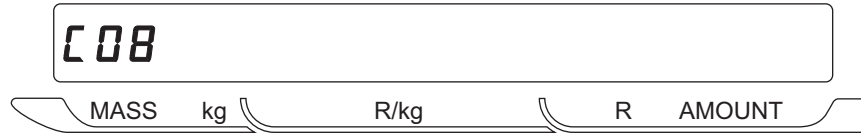

- 0: AC-4000B
- 1: AC-4000
- 2: AC-4000D
- 3: AC-4000H
- 4: AC-4000E

CHAPTER 4 SETUP MODE

4.1 Setup Mode Menu

■ Setup menu list

- Labels

- a) Print condition
 - 1. Label format No.
 - 2. Label length including pitch
 - 3. Item name returning line width (when registering)
 - 4. Label sensor distance
 - 5. Continuous paper label
 - 6. Store name/address print
 - 7. Field title print
 - 8. Peel sensor mode
 - 9. Default PLU (PLU for test printing)
 - 10. Thermal head fault check
 - 11. Subtotal label format No.
 - 12. Store No. print
 - 13. Machine No. print

- b) Label format edit

- POS code

- a) Flag setting (Non-PLU)
- b) Flag setting (PLU)
- c) POS code system
- d) POS code type (Non-PLU)
- e) ITF code type (China specification)
- f) Manufacturer code

- Item code

- Reference data position in bar code

- Default data (Initial value of external reference data)

- a) Default value of date print flag
- b) Expiry date
- c) Processing time
- d) Expiry time
- e) Unit type

- Total addition

- Available/Not available

- Unit price change prohibition (open price)

- Available/Not available

- Menu selection of PLU registration

- System (Registration menu selection)

- Ethernet setting
 - a) IP address
 - b) Gateway address setup
 - c) Subnet mask setup
 - d) Server address setup
 - e) Log-in name setup
 - f) Password setup
 - g) Mac address setup
 - h) DHCP setup
 - i) Network status

- System timer

- Password setting
 - a) Password
 - b) Registration
 - c) Total
 - d) Subtraction
 - e) Setup

4.2 Starting Procedure for Each Mode

- Setup mode: Enter “6000”, and press the MODE key.
- Subtraction: Enter “7000”, and press the MODE key.
- Total: Enter “8000”, and press the MODE key.
- Registration: Enter “9000”, and press the MODE key.

4.3 Starting Procedure for Setup Mode

- Enter “6000”, and press the MODE key to enter SETUP MODE from normal or other mode.
- Press the [↓] key to increment a menu.

Setup mode menu screen

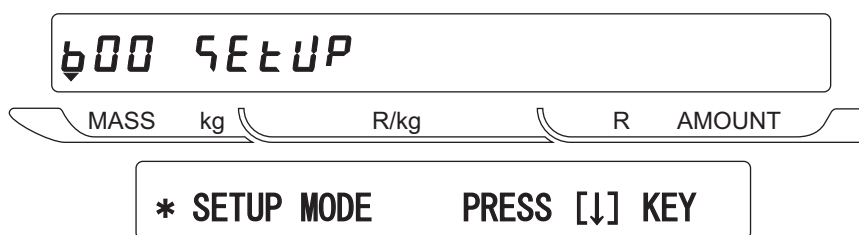

- Press the [↓] key to increment a menu, or enter a desired menu number followed by pressing the [↓] key.



4.4 Label Format [Print conditions]

■ LABEL FORMAT

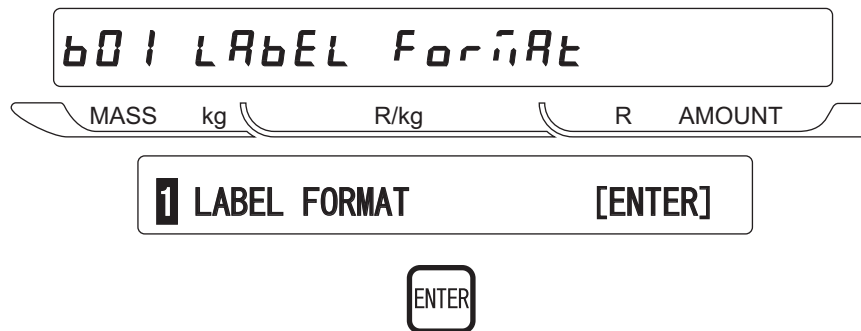

■ PRINT SETUP [Print condition setting mode]

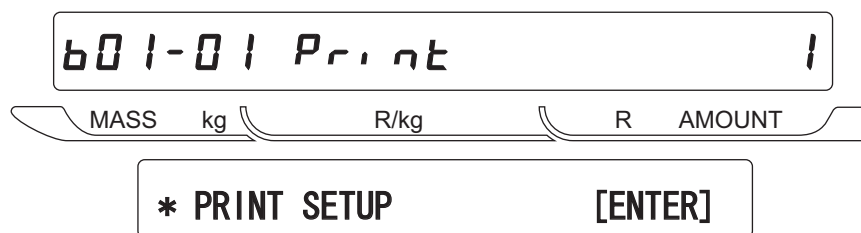

■ LABEL FORMAT No. [Specifying label format number]

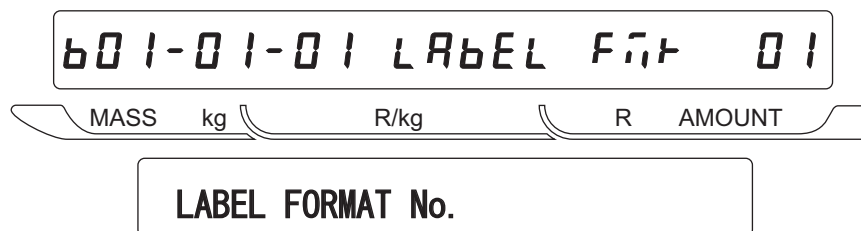

- #1 to #4" are standard formats. (# 10 to #99 can be additionally registered.)
- # 1 is a default when a format number in which there is no specified data.
- Enter the format number, and press the ENTER key.

■ LABEL LENGTH + GAP [Setting label length]

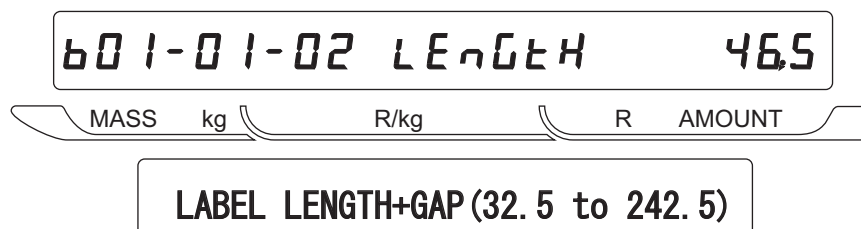

Enter the label length and label pitch in 0.1 mm unit.

■ LABEL WIDTH [Setting of item name area print width]

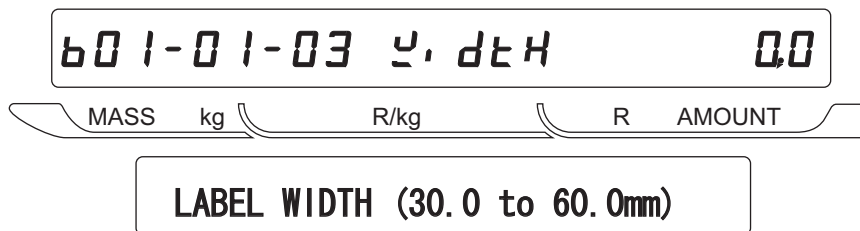

- This reflect an automatic line returning for an item name registration.
- When (0.0) is set, a line returning is carried out automatically based on the default value.

■ LABEL SENSOR DISTANCE [Setting a distance between label sensor and thermal head]

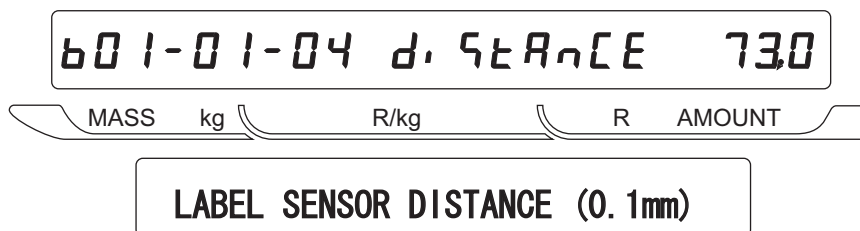

Enter a numerical value in 0.1 mm unit.

■ LABEL DIE-CUT, CONTINUOUS [Specifying label (Die-cut label/Continuous paper)]



Selection 0: Die-cut label 1: Continuous labels

■ STORE NAME, ADDRESS [Specifying whether to print store name/address or not]

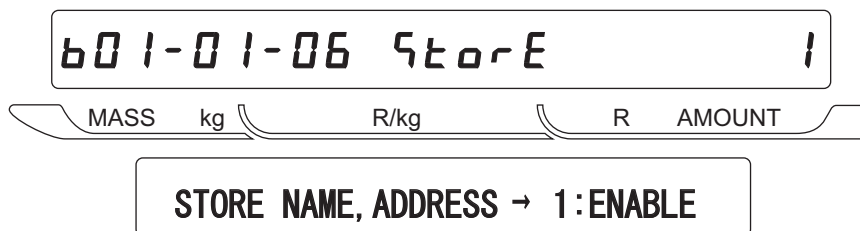

Selection 0: Disable 1: Enable

■FIELD TITLE PRINT [Specifying whether to print field title in advance or not]

601-01-07 t, tLE 1

MASS kg R/kg R AMOUNT

FIELD TITLE PRINT → 1:ENABLE

Selection 0: No 1: YES

■PEEL SENSOR [Setting availability of peel sensor]

601-01-08 PEEL 1

MASS kg R/kg R AMOUNT

PEEL SENSOR → 1:ENABLE

Selection 0: DISABLE 1: ENABLE

■TEST ITEM No. [Specifying PLU number for test print]

601-01-09 , tEñ 000001

MASS kg R/kg R AMOUNT

TEST ITEM No.

Enter a PLU number when performing test print.

■THERMAL HEAD CHECK [Specifying availability of thermal head fault display]

601-01-10 HEAD CHECK 0

MASS kg R/kg R AMOUNT

THERMAL HEAD CHECK → 0:DISABLE

Selection 0: DISABLE (No error display) 1: ENABLE (Error display)

Note: Thermal head is available only when "C06-00" No. 17 of the E2ROM switch is set "1".

*No. 17 (Head fault check) 0: DISABLE 1: ENABLE

■SUBTOTAL LABEL FORMAT No. [Setting availability of specifying the label format]

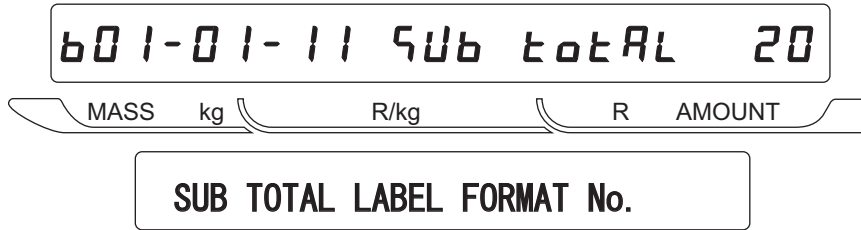

Enter the format number.

■STORE No. PRINT [Setting availability of specifying the shop number]



Selection 0: DISABLE 1: ENABLE

■MACHINE No. PRINT [Setting availability of specifying the machine number]

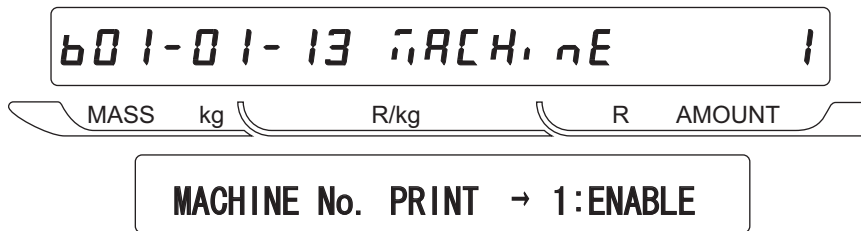

Selection 0: DISABLE 1: ENABLE

■ LABEL FORMAT EDIT [Editing label format]

- How to enter label format edit mode.
Enter a password “4141”, and press the SIZE key.

Note: A protection is released when the above operation has been performed.

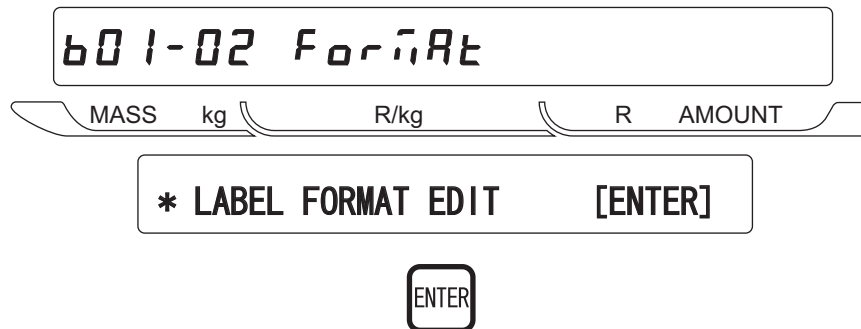

- Enter a label format number, and press the PLU key to call.

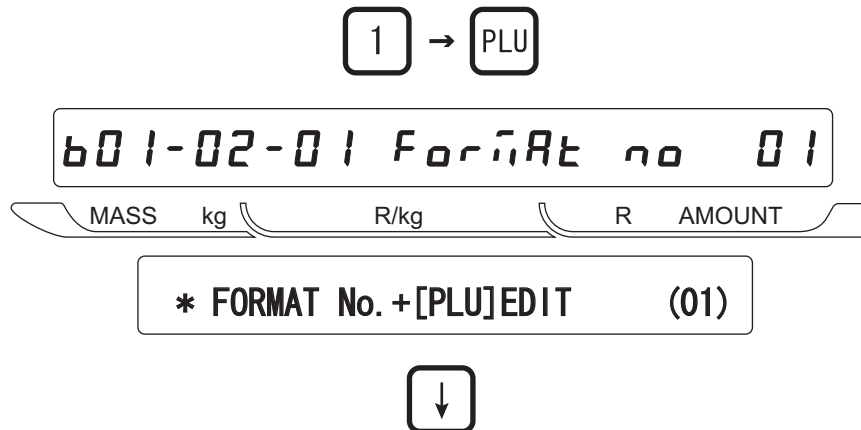

■ FORMAT No. + [PLU] [Copying format]

*New label format edit (Example: Format No. 50)

- Enter “50” and press the PLU key to call a label format.
- Enter “1” and press the COPY key to copy FORMAT No.1 data to FORMAT No.50.

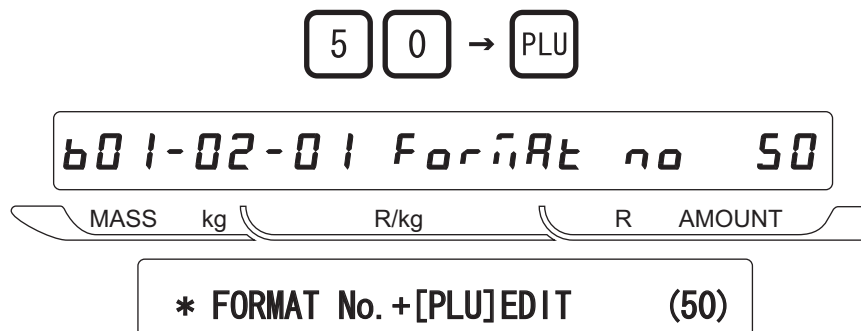

■UNIT [X/Y axis position selection]

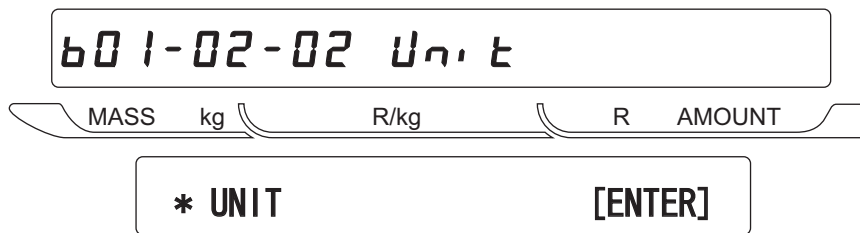

Press the ENTER key to select X or Y axis position.

“X” AXIS POSITION

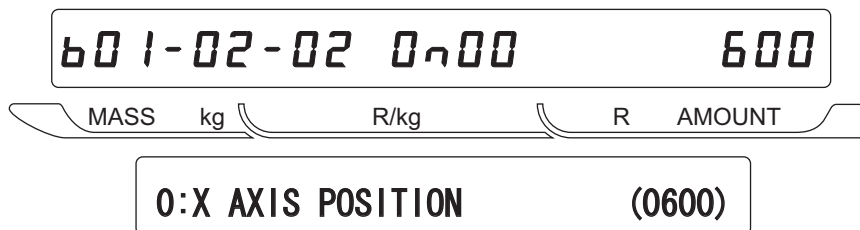

“Y” AXIS POSITION

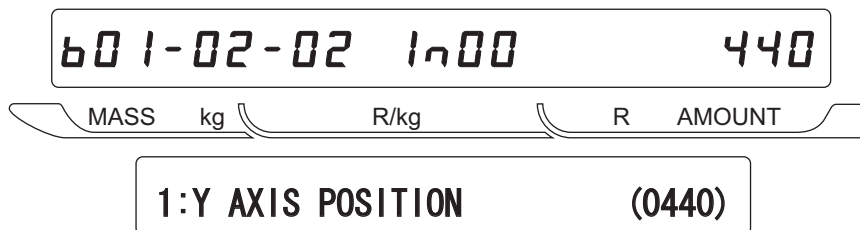

- Select “X axis position data” or “Y axis position data” using the [→] key.
- Multiple tube display
 N00 : Label format unit # (1 to 50)
 600 : X axis position is adjusted in 0.1mm unit.
 400 : Y axis position is adjusted in 0.1mm unit.

■DEFAULT PLU

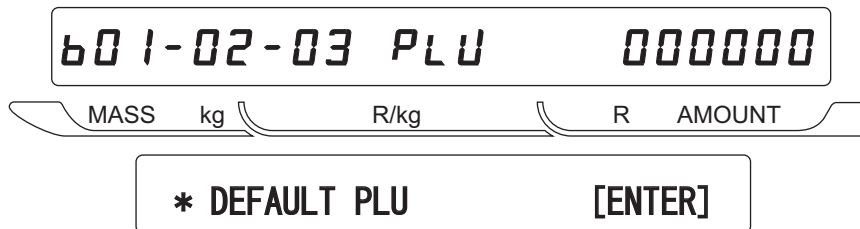

Specify a default PLU for test print.

■UNIT DATA [Editing the unit data]

b0 1-02-04

MASS kg R/kg R AMOUNT

* UNIT DATA [ENTER]

Move the edit position by using [→][←][↑][↓] keys and rewrite the data.

b0 1-02-04 AA bb CC dd

MASS kg R/kg R AMOUNT

FMT No. /Unit No. /Address/Data

AA: label format number

BB: Unit number (1 to 50)

CC: Address data in the unit

DD: Input data

■NUMBER OF UNITS

b0 1-02-05 no of Unit

MASS kg R/kg R AMOUNT

NUMBER OF UNIT [ENTER]

Specify the total number of units. The number specified here specifies the number of units including the label format specified at this point.

Specifiable number of units (1 to 50)

b0 1-02-05 no of Unit 24

MASS kg R/kg R AMOUNT

NUMBER OF UNIT

■LABEL LENGTH

Set the label length for each label. (This is prioritized over B01-01-02)

Specify the label length and the pitch between labels.

b0 1-02-06 LENGTH 00

MASS kg R/kg R AMOUNT

LABEL LENGTH+GAP (32.5 to 242.5)

4.5 POS Code

■ POS CODE

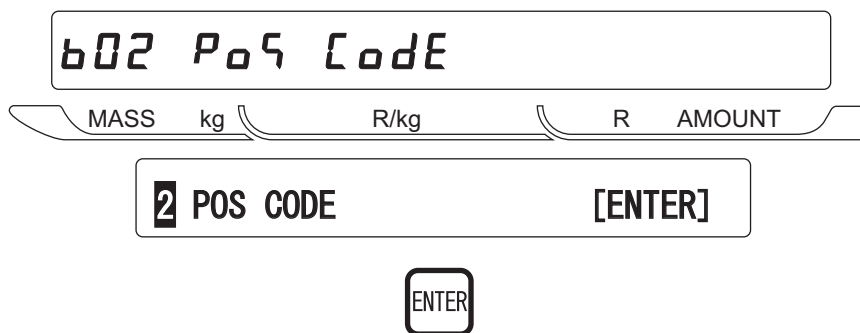

■ POS FLAG 8/3 [Setting a NON PLU flag]

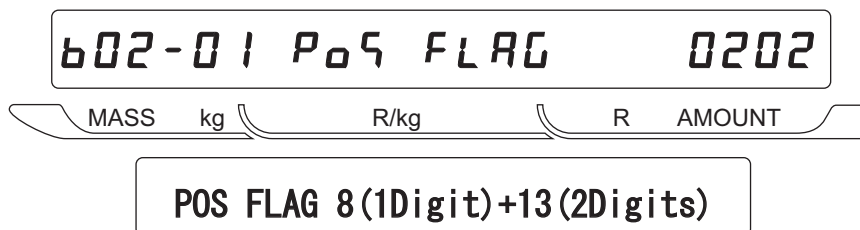

Set one or two digits if necessary.

■ 10 DIGIT FLAG 8/13 [Setting a PLU flag for source marking]

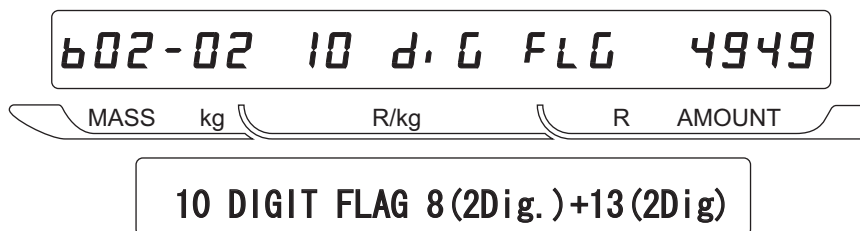

Set a flag code for source marking.

■ POS TYPE [Setting a POS type]



Selection

- | | |
|---------------|--------------|
| 1: NON PLU 13 | 2: NON PLU 8 |
| 3: PLU 13 | 4: PLU 8 |
| 5: ITF 18 | |

■BAR TYPE [Setting NON PLU 13 code]

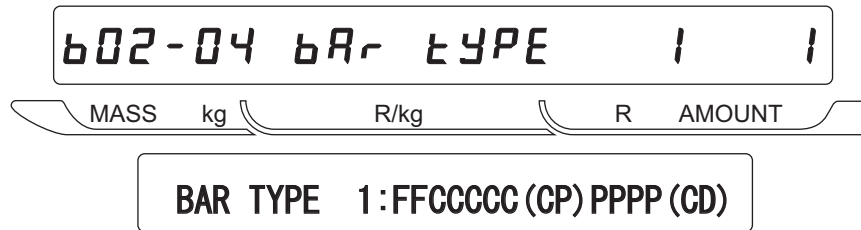

- Set the POS code type “NON PLU 13 code”.

- Meaning of abbreviation

F	: Flag	M	: Manufacturer code	C	: Item code
(CP)	: Check price	P	: Price	(0)	: 0
E	: Weight	Q	: Quantity	I	: PLU no.

- POS code type (NON PLU 13 code)

1. FFCCCC(CP)PPPP : Standard 5 digits
2. FFCCCCPPPP : 2 digit flag + 6 digit code + 4 digit price
3. FCCCC(CP)PPPP : 1 digit flag + 6 digit code + Check price + 4 digit price
4. FFCCCCPPPP : 2 digit flag + 5 digit code + 5 digit price
5. FCCCCPPPP : 1 digit flag + 6 digit code + 5 digit price
6. FFCCC(CP)PPPP : 2 digit flag + 4 digit code + Check price + 5 digit price
7. FFCCCCWWWW : 2 digit flag + 6 digit code + 4 digit weight
8. FCCCCWWWWW : 1 digit flag + 6 digit code + 5 digit weight
9. FCCCCIIIII : 1 digit flag + 5 digit code + 6 digit PLU
10. FFCCCCPPPP : 2 digit flag + 6 digit code + 4 digit price EAN
11. FFCCCCWWWW : 2 digit flag + 6 digit code + 4 digit weight EAN

Note: In a normal barcode, if the price or weight becomes over fixed digits, the barcode will not be printed out. For example, 4-digit prices will only print out up to 9,999. Barcodes will not be printed for prices over 10,000. In “EAN” code, prices over a given digit number will only print out the upper digits. Therefore, if the price is 10,000, the barcode (EAN code) will be printed as 1,000. Note that EAN code flags are fixed 2X. When one lower digit is deleted, the second digit of the flag will be increased.

12. FFCCC(CP)WWWWW : 4 digit item code + (CP) + 5 digit weight
13. FFMCCPPPP : 2 digit flag + 3 digit manufacturer code + 2 digit code + 5 digit price
14. FFMCCPPPP : 2 digit flag + 2 digit manufacturer code + 3 digit code + 5 digit price
15. FFCCC(0)PPPP : 2 digit flag + 5 digit code + 0 + 4 digit price
16. FFCCCCWWWWW : 2 digit flag + 5 digit code + 5 digit weight
17. FFCCCCPPPP : 2 digit flag + 5 digit code + 5 digit price

Note: The least significant digit of the total amount is omitted for barcode printing.

18. FFCCC(CP)PPPP : 2 digit flag + 5 digit code + Check price + 4 digit price
19. FFCCC(CP)WWWW : 2 digit flag + 5 digit code + Check price + 4 digit weight

Note: The least significant digit of the total amount is omitted for barcode printing.

20. FCCCCPPPP : 1 digit flag + 5 digit code + 6 digit price
21. FFCCCPPPP : 2 digit flag + 4 digit code + 6 digit price
22. FCCWWWWPPPP : 1 digit flag + 3 digit code + 4 digit weight + 4 digit price
23. FFCCCQPPPP : 2 digit flag + 4 digit code + 2 digit quantity + 4 digit price
24. FIIIIIPPP : 1 digit flag + 6 digit PLU + 5 digit price
25. FFIIIIIPPP : 2 digit flag + 6 digit PLU + 4 digit price
26. FCCCPPPPP : 1 digit flag + 4 digit code + 7 digit price
27. FIIIIIPPP : 1 digit flag + 6 digit PLU + 5 digit price (1/10)
28. FFIIIIIPPP : 2 digit flag + 6 digit PLU + 4 digit price (1/10)
29. FCCCCPPPP : 1 digit flag + 6 digit code + 5 digit price (1/10)
30. FFCCCCPPPP : 2 digit flag + 6 digit PLU + 4 digit price (1/10)
31. FFCCCCQQQQ : 2 digit flag + 5 digit code + 5 digit quantity

■ITF [Setting ITF code]

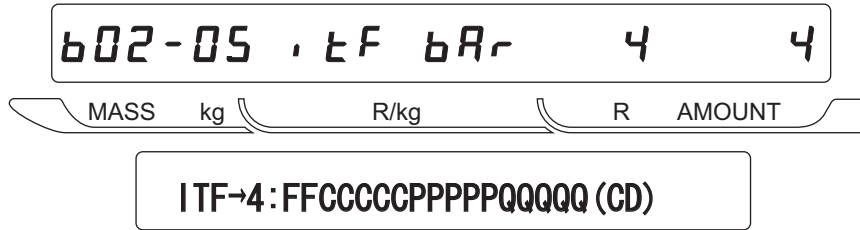

- Set an ITF code type “NON PLU 18 code”.

• Meaning of abbreviation

- | | |
|---------------|-----------------------|
| F : Flag | M : Manufacturer code |
| C : Item code | Q : Quantity |
| P : Price | U : Unit price |
| W : Weight | (CD): Check digit |

• POS code type (Non PLU 13 code)

1. FFCCCCPPPPP W5/Q5(CD) : “3” or “4” is automatically selected. (Weighing/fixed price item)
2. FFCCCCUUUUUWWWWW(CD) : 2 digit flag + 5 digit code + 5 digit unit price + 5 digit weight
3. FFCCCCPPPPPWWWWW(CD): 2 digit flag + 5 digit code + 5 digit price + 5 digit weight
4. FFCCCCPPPPPQQQQQ(CD) : 2 digit flag + 5 digit code + 5 digit price + 5 digit quantity

- The FFCCCCPPPPPQQQQQ(CD) type ITF barcode is printed for a fixed price item when ITF is set “1”. And the FFCCCCPPPPPWWWWW(CD) type ITF barcode is printed for an weighing item.

■MANUFACTURE CODE

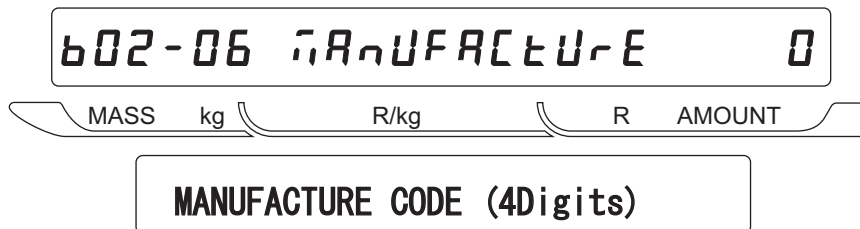

Specify a manufacturer code.

4.6 Item Code

■ITEM CODE POSITION

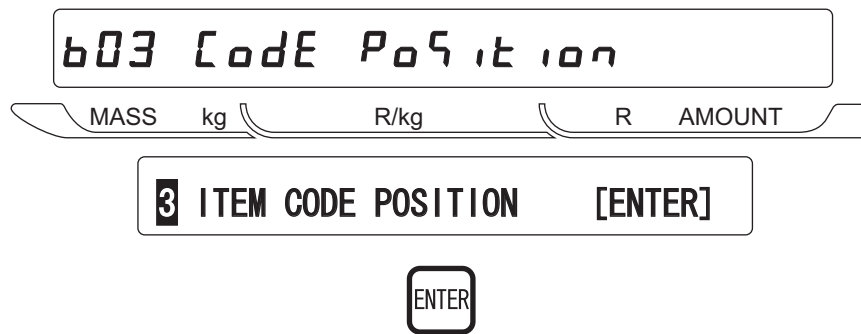

■BARCODE POSITION [Setting an item code]

- Set "Position" and "Number of digits" of the item code to be reflected in the barcode.

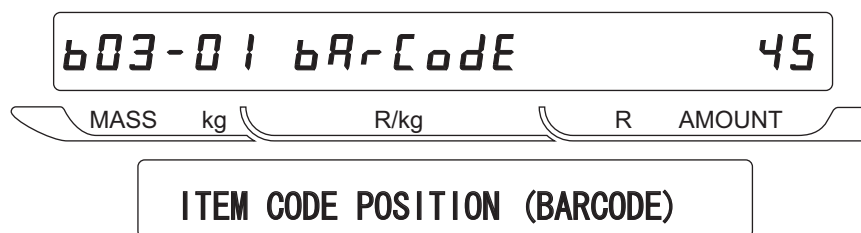

- "45" is a default value specifying the five digits from the upper fourth digit in 8 digit item code are taken in the barcode.

:For example, "45678" (12345678) is taken in the barcode.

■DEPARTMENT CODE

- Set "Position" and "Number of digits" of the item code to be reflected on the department code.

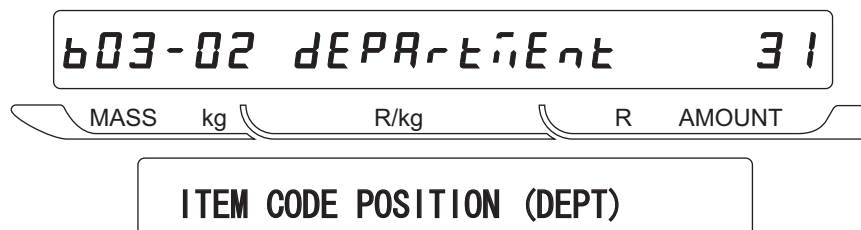

- "31" is a default value specifying one digit from the upper third digit in 8 digit item code.

:For example, "3" (12345678) is taken in the department code.

■GROUP CODE

- Set "Position" and "Number of digits" of the item code to be reflected on the group code.

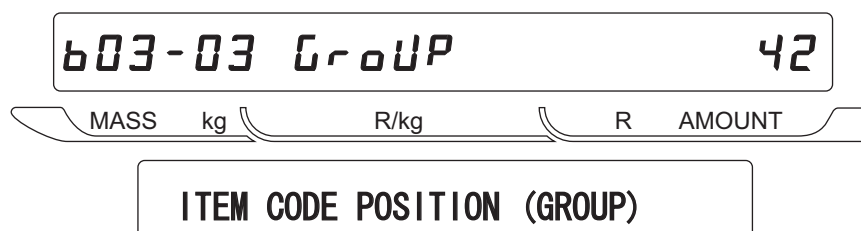

- "42" is a default value specifying two digits from the upper fourth digit in 8 digit item code.

:For example, "45" (12345678) is taken in the group code.

4.7 Default Data

■DEFAULT DATA

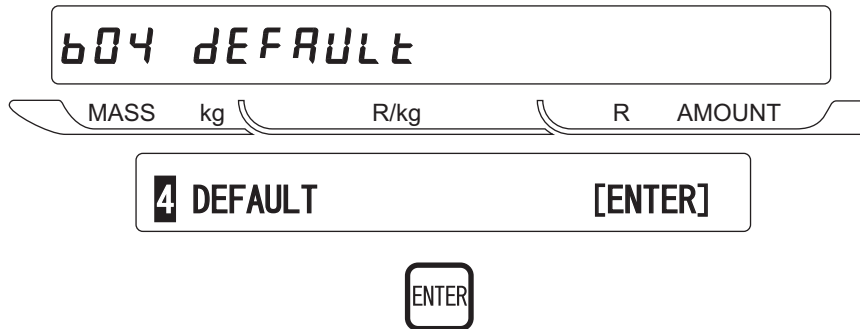

■DATE PRINT FLAG

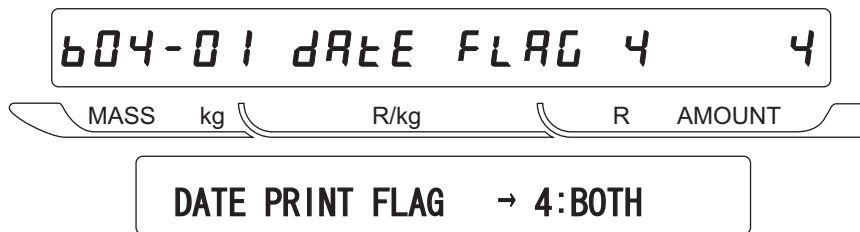

Selection

- 1: Print prohibited
- 2: Packing date print
- 3: Expiry date print
- 4: Both packing date and expiry date print = defaults

■USED BY [Setting the number of days for expiry date]

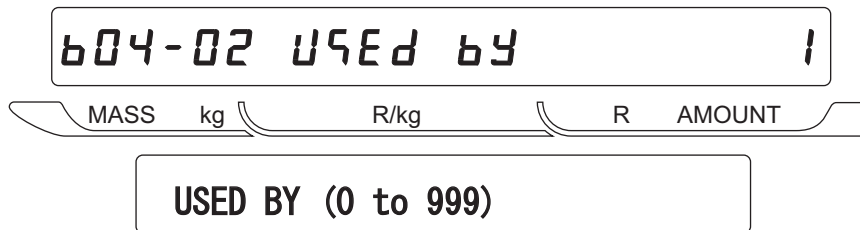

Specify the number of days for an expiry date. "1" denotes "Today".

■PACKING TIME FLAG [Setting a print flag for packing time print]

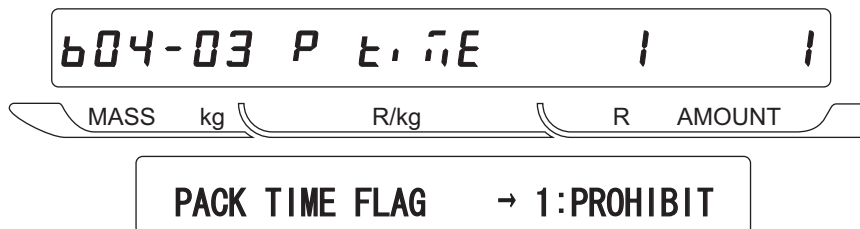

- #### Selection
- 1: Prohibit
 - 2: Installed
 - 3: Designated

■ EXPIRY TIME FLAG

604-04 E t. nE 1 1

MASS kg R/kg R AMOUNT

EXPIRY TIME FLAG → 1:PROHIBIT

Selection 1: Prohibit 2: Relative
3: Designated

■ BEST BEFORE FLAG

604-05 bEFoRE F 1 1

MASS kg R/kg R AMOUNT

BEST BEFORE FLAG → 1:NO PRINT

Selection 1: No print 2: Print

■ BEST BEFORE DATE

604-06 bEFoRE d 1

MASS kg R/kg R AMOUNT

BEST BEFORE DATE (0 to 999)

Specifiable up to 999 days.

■ UNIT TYPE

604-07 UnIt tYPE 5 5

MASS kg R/kg R AMOUNT

UNIT TYPE → 5:PC(S).

Selection

1 : oz	2 : lb	3 : kg	4 : g	5 : pc.
6 : box	7 : bundle	8 : pack	9 : cut	10 : slice
11 : cup	12 : pkt	13 : bag	14 : bunch	15 : bottle
16 : LB				

4.8 Total Mode Select

■TOTAL MODE SELECT

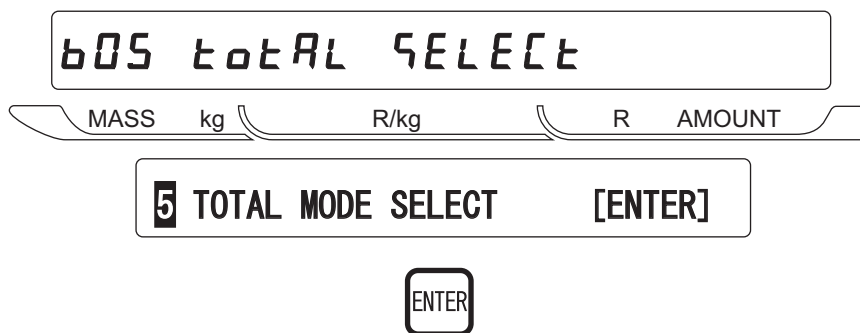

■DAILY TOTAL

Select availability of daily total when issuing labels. (Default value 1: Enable)

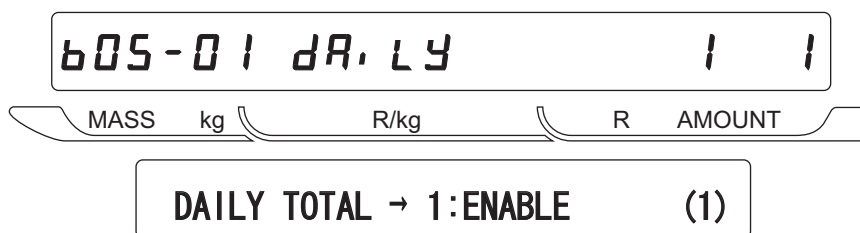

Selection 0: Disable 1: Enable

■WEEKLY TOTAL

Select availability of weekly total when issuing labels. (Default value 1: Enable)

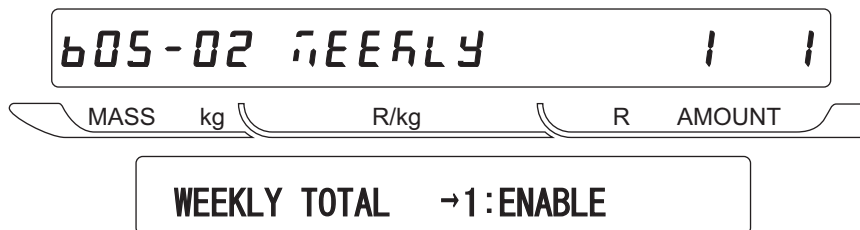

Selection 0: Disable 1: Enable

■MONTHLY TOTAL

Select availability of monthly total when issuing labels. (Default value 1: Enable)

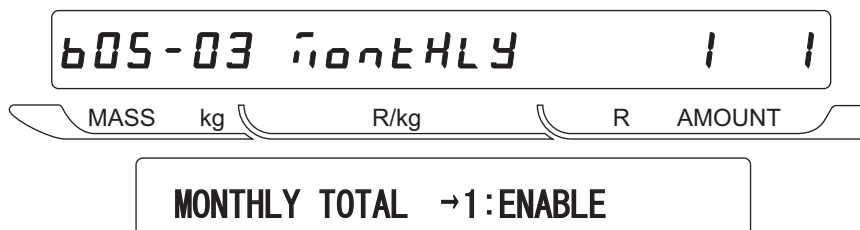

Selection 0: Disable 1: Enable

4.9 Open Price [Prohibition of Unit Price Change]

■ OPEN PRICE

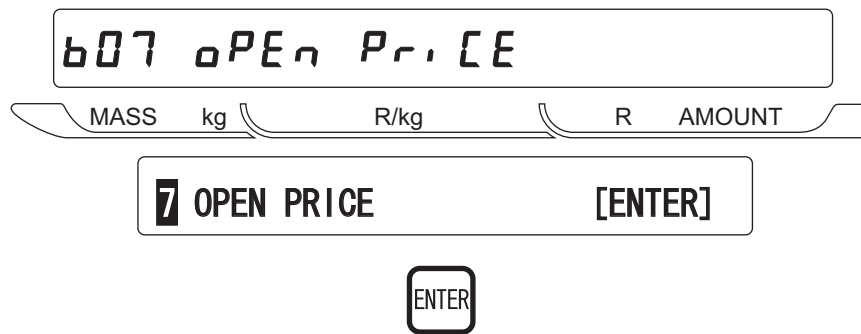

■ OPEN PRICE AVAILABILITY [Selection of open price or unit price change prohibition]

- Select a temporary unit price change or a open price in normal mode.

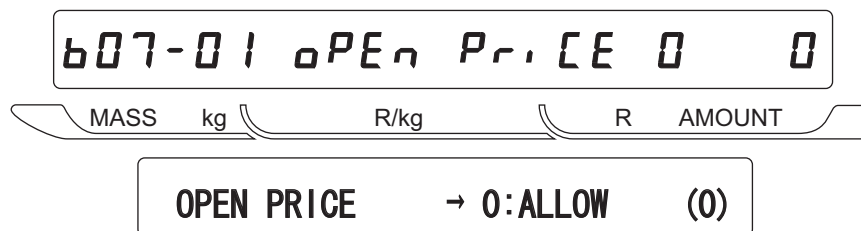

- Selection
- 0: Open price (Allow) Default
 - 1: Temporary unit price change prohibited (Prohibit)

4.10 PLU Select [Editing PLU File]

■PLU SELECT

608 PLU SELECT

MASS kg R/kg R AMOUNT

8 PLU SELECT [ENTER]

ENTER

■SALES MODE

608-02 SALES mode 1 1

MASS kg R/kg R AMOUNT

SALES MODE → 1:ENABLE

Selection 0: Disable 1: Enable

■UNIT PRICE

608-03 Price 1 1

MASS kg R/kg R AMOUNT

UNIT PRICE → 1:ENABLE

Selection 0: Disable 1: Enable

■MD (Mark Down) FLAG

608-04 1 1

MASS kg R/kg R AMOUNT

MD FLAG → 1:ENABLE

Selection 0: Disable 1: Enable

■MD (Mark Down) PRICE

608-05 MD Price 1 1

MASS kg R/kg R AMOUNT

MD PRICE → 1:ENABLE

Selection 0: Disable 1: Enable

■FIXED WEIGHT

b08-06 F. WEI. WT. 1 1

MASS kg R/kg R AMOUNT

FIXED WEIGHT → 1:ENABLE

Selection 0: Disable 1: Enable

■PCS (Quantity)

b08-07 PACK QUANT. 1 1

MASS kg R/kg R AMOUNT

PACK QUANTITY → 1:ENABLE

Selection 0: Disable 1: Enable

■TARE

b08-08 TARE 1 1

MASS kg R/kg R AMOUNT

TARE → 1:ENABLE

Selection 0: Disable 1: Enable

■DATE PRINT

b08-09 DATE PRINt 1 1

MASS kg R/kg R AMOUNT

DATE PRINT → 1:ENABLE

Selection 0: Disable 1: Enable

■USED BY

b08-10 USED BY 1 1

MASS kg R/kg R AMOUNT

USED BY → 1:ENABLE

Selection 0: Disable 1: Enable

■BEST BEFORE DATE FLAG

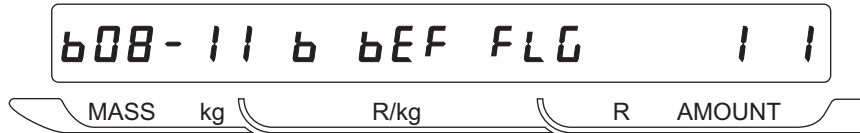

BEST BEFORE FLAG → 1:ENABLE

Selection 0: Disable 1: Enable

■BEST BEFORE DATE

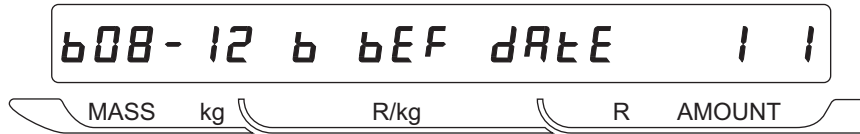

BEST BEFORE DATE → 1:ENABLE

Selection 0: Disable 1: Enable

■PACKING TIME FLAG

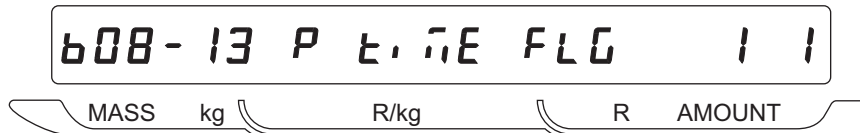

P. TIME FLAG → 1:ENABLE

Selection 0: Disable 1: Enable

■PACKING TIME DATA

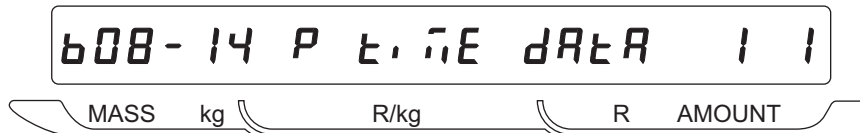

P. TIME DATA → 1:ENABLE

Selection 0: Disable 1: Enable

■EXPIRY TIME FLAG

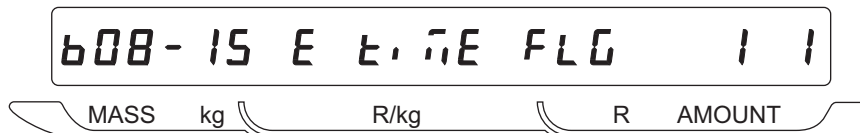

E. TIME FLAG → 1:ENABLE

Selection 0: Disable 1: Enable

■EXPIRY TIME DATA

b08-16 E.T. DATA 1 1

MASS kg R/kg R AMOUNT

E. TIME DATA → 1:ENABLE

Selection 0: Disable 1: Enable

■ITEM CODE

b08-17 . E.T. CODE 1 1

MASS kg R/kg R AMOUNT

ITEM CODE → 1:ENABLE

Selection 0: Disable 1: Enable

■BARCODE TYPE

b08-18 BAR TYPE 1 1

MASS kg R/kg R AMOUNT

BAR TYPE → 1:ENABLE

Selection 0: Disable 1: Enable

■POS CODE TYPE

b08-19 POS TYPE 1 1

MASS kg R/kg R AMOUNT

POS TYPE → 1:ENABLE

Selection 0: Disable 1: Enable

■POS CODE FLAG

b08-20 POS FLAG 1 1

MASS kg R/kg R AMOUNT

POS FLAG → 1:ENABLE

Selection 0: Disable 1: Enable

■POS CODE

b08-21 POS CODE 1 1

MASS kg R/kg R AMOUNT

POS CODE → 1:ENABLE

Selection 0: Disable 1: Enable

■OPEN PRICE

b08-22 OPEN PRICE 1 1

MASS kg R/kg R AMOUNT

OPEN PRICE → 1:ENABLE

Selection 0: Disable 1: Enable

■EXTRA MESSAGE 1

b08-23 MESSAGE 1 1 1

MASS kg R/kg R AMOUNT

EXTRA MESSAGE1 → 1:ENABLE

Selection 0: Disable 1: Enable

■EXTRA MESSAGE 2

b08-24 MESSAGE 2 1 1

MASS kg R/kg R AMOUNT

EXTRA MESSAGE2 → 1:ENABLE

Selection 0: Disable 1: Enable

■EXTRA MESSAGE 3

b08-25 MESSAGE 3 1 1

MASS kg R/kg R AMOUNT

EXTRA MESSAGE3 → 1:ENABLE

Selection 0: Disable 1: Enable

■ COUPON MESSAGE

b08-26 COUPON 1 1

MASS kg R/kg R AMOUNT

COUPON MESSAGE → 1:ENABLE

Selection 0: Disable 1: Enable

■ LOGO IMAGE 1

b08-27 LOGO 1 1 1

MASS kg R/kg R AMOUNT

LOGO IMAGE 1 → 1:ENABLE

Selection 0: Disable 1: Enable

■ LOGO IMAGE 2

b08-28 LOGO 2 1 1

MASS kg R/kg R AMOUNT

LOGO IMAGE 2 → 1:ENABLE

Selection 0: Disable 1: Enable

■ LABEL FORMAT No.

b08-29 FORMAT 1 1 1

MASS kg R/kg R AMOUNT

LABEL FORMAT No. → 1:ENABLE

Selection 0: Disable 1: Enable

■ UPPER LIMIT

b08-32 UPPER 1 1

MASS kg R/kg R AMOUNT

UPPER LIMIT → 1:ENABLE

Selection 0: Disable 1: Enable

■LOWER LIMIT

b08-33 Lower 1 1

MASS kg R/kg R AMOUNT

LOWER LIMIT → 1:ENABLE

Selection 0: Disable 1: Enable

■UNIT TYPE

b08-34 Unit type 1 1

MASS kg R/kg R AMOUNT

UNIT TYPE → 1:ENABLE

Selection 0: Disable 1: Enable

■DEPARTMENT CODE

b08-35 Dept 1 1

MASS kg R/kg R AMOUNT

DEPARTMENT CODE → 1:ENABLE

Selection 0: Disable 1: Enable

■GROUP CODE

b08-36 Group 1 1

MASS kg R/kg R AMOUNT

GROUP CODE → 1:ENABLE

Selection 0: Disable 1: Enable

■REGISTER CODE

b08-37 Register 1 1

MASS kg R/kg R AMOUNT

REGISTER CODE → 1:ENABLE

Selection 0: Disable 1: Enable

■ COST PRICE

b08-38 Cost 1 1

MASS kg R/kg R AMOUNT

COST PRICE → 1:ENABLE

Selection 0: Disable 1: Enable

■ POP MESSAGE

b08-39 POP 1 1

MASS kg R/kg R AMOUNT

POP MESSAGE → 1:ENABLE

Selection 0: Disable 1: Enable

4.11 System [Availability of Registration Mode Menu]

■SYSTEM

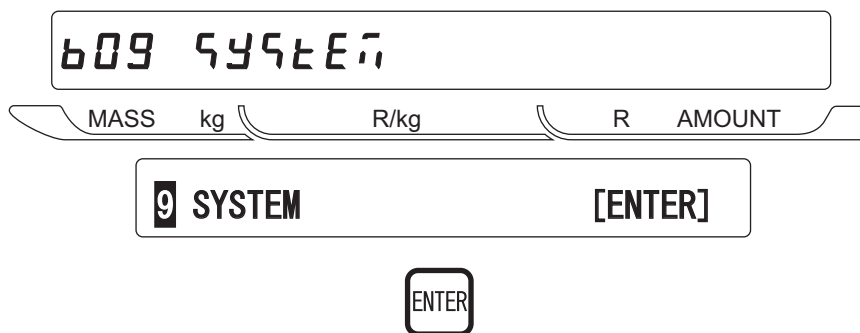

■PLU

- A function to protect PLU data.

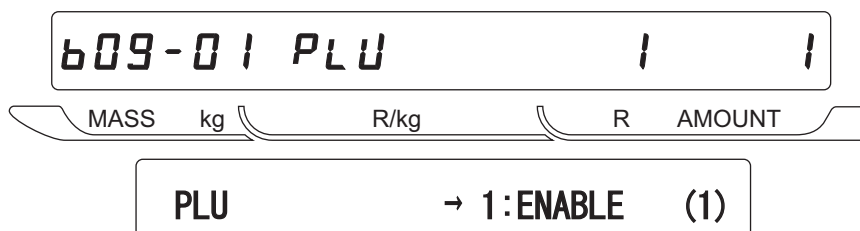

Selection 0: Disable 1: Enable

Note: P01 and P03 mode can not be used.

■COMMODITY NAME



Selection 0: Disable 1: Enable (Default)

■PRESET KEY



Selection 0: Disable 1: Enable

■STORE ADDRESS

609-05 STORE 1 1

MASS kg R/kg R AMOUNT

STORE ADDRESS → 1:ENABLE (1)

Selection 0: Disable 1: Enable

■DATE

609-06 DATE 1 1

MASS kg R/kg R AMOUNT

DATE → 1:ENABLE (1)

Selection 0: Disable 1: Enable

■EXTRA MESSAGE 1

609-07 MESSAGE 1 1 1

MASS kg R/kg R AMOUNT

EXTRA MESSAGE1 → 1:ENABLE (1)

Selection 0: Disable 1: Enable

■OPEN PLU

609-08 OPEN PLU 1 1

MASS kg R/kg R AMOUNT

OPEN PLU → 1:ENABLE (1)

Selection 0: Disable 1: Enable

■ITEM LIST

609-09 L. ST 1 1

MASS kg R/kg R AMOUNT

ITEM LIST → 1:ENABLE (1)

Selection 0: Disable 1: Enable

■RS232C COMMUNICATION

b09-10 R232C 1 1
MASS kg R/kg R AMOUNT

RS232C COMM → 1:ENABLE (1)

Selection 0: Disable 1: Enable

■COUPON MESSAGE

b09-20 COUPON 1 1
MASS kg R/kg R AMOUNT

COUPON MESSAGE → 1:ENABLE (1)

Selection 0: Disable 1: Enable

■EXTRA MESSAGE2

b09-21 MESSAGE 2 1 1
MASS kg R/kg R AMOUNT

EXTRA MESSAGE2 → 1:ENABLE (1)

Selection 0: Disable 1: Enable

■EXTRA MESSAGE3

b09-22 MESSAGE 3 1 1
MASS kg R/kg R AMOUNT

EXTRA MESSAGE3 → 1:ENABLE (1)

Selection 0: Disable 1: Enable

■TCP/IP COMMUNICATION

b09-23 TCP,IP 1 1
MASS kg R/kg R AMOUNT

TCP/IP COMM → 1:ENABLE (1)

Selection 0: Disable 1: Enable

■ OPERATOR NAME

MASS kg R/kg R AMOUNT

OPERATOR → 1:ENABLE (1)

Selection 0: Disable 1: Enable

■ TITLE MESSAGE

MASS kg R/kg R AMOUNT

TITLE MESSAGE → 1:ENABLE (1)

Selection 0: Disable 1: Enable

■ ADVERTISEMENT MESSAGE

MASS kg R/kg R AMOUNT

ADVERTISEMENT → 1:ENABLE (1)

Selection 0: Disable 1: Enable

■ DEPARTMENT

MASS kg R/kg R AMOUNT

DEPARTMENT → 1:ENABLE (1)

Selection 0: Disable 1: Enable

■ GROUP

MASS kg R/kg R AMOUNT

GROUP → 1:ENABLE (1)

Selection 0: Disable 1: Enable

■CAMPAIGN ITEM

609-29 [A, P, G] 1 1
MASS kg R/kg R AMOUNT

CAMPAIGN ITEM → 1:ENABLE (1)

Selection 0: Disable 1: Enable

4.12 Ethernet Setup [Ethernet Data Setting]

■ETHERNET SET

b 10 EtHERnEt

MASS kg R/kg R AMOUNT

10 ETHERNET SETUP [ENTER]

ENTER

■IP ADDRESS SETUP

- Set an Internet Protocol address.

b 10-01 . P AddrE55

MASS kg R/kg R AMOUNT

* IP ADDRESS SETUP [ENTER]

- Enter an Internet Protocol address. (Enter a data divided with the period individually.)

b 10-01-01 Addr 1 192

MASS kg R/kg R AMOUNT

IP ADDRESS 1 (192)

b 10-01-02 Addr 2 168

MASS kg R/kg R AMOUNT

IP ADDRESS 2 (168)

b 10-01-03 Addr 3 10

MASS kg R/kg R AMOUNT

IP ADDRESS 3 (10)

b 10-01-04 Addr 4 1

MASS kg R/kg R AMOUNT

IP ADDRESS 4 (1)

■ GATEWAY ADDRESS SETUP

- Set a gateway address.



* GATEWAY ADDRESS SETUP[ENTER]

- Enter a gateway address. (Enter a data divided with the period individually.)

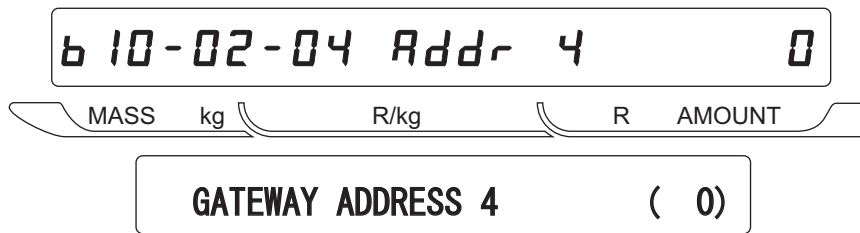
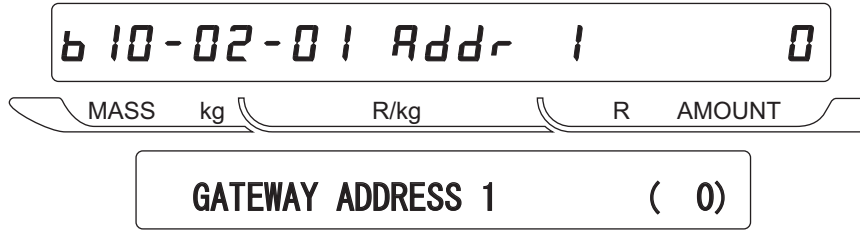

■ SUBNET MASK SETUP

- Set a subnet mask.

b 10-03 Subnet

MASS kg R/kg R AMOUNT

* SUBNET MASK SETUP [ENTER]

- Enter a subnet mask. (Enter a data divided with the period individually.)

b 10-03-01 Addr 1 255

MASS kg R/kg R AMOUNT

SUBNET MASK 1 (255)

b 10-03-02 Addr 2 255

MASS kg R/kg R AMOUNT

SUBNET MASK 2 (255)

b 10-03-03 Addr 3 255

MASS kg R/kg R AMOUNT

SUBNET MASK 3 (255)

b 10-03-04 Addr 4 0

MASS kg R/kg R AMOUNT

SUBNET MASK 4 (0)

■SERVER ADDRESS SETUP

- Set a server address.



- Enter a server address. (Enter a data divided with the period individually.)

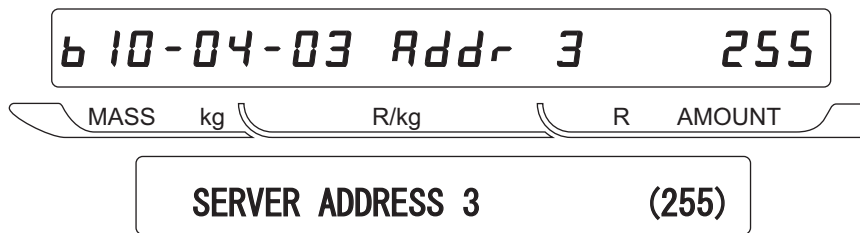

■ LOG-IN NAME ADDRESS SETUP

- Set a log-in name.

b 10-05 LOGIN

MASS kg R/kg R AMOUNT

* LOGIN NAME SETUP [ENTER]

- Enter a log-in name using numeric or character keys. Characters must be lower-case letters.

b 10-05-01 L tEt

MASS kg R/kg R AMOUNT

LOGIN NAME (test)

■ PASSWORD SETUP

- Set a password.

b 10-06 PASSWORD

MASS kg R/kg R AMOUNT

* PASSWORD SETUP [ENTER]

- Enter a password using numeric or character keys. Characters must be lower-case letters.

b 10-06-01 P usnet

MASS kg R/kg R AMOUNT

PASSWORD (usnet)

■MAC ADDRESS SETUP

- Checking MAC address
- As the MAC address is unique to the CPU board, modified use is strictly prohibited. When the board is exchanged, Use the MAC address memorized in a new board. If the stored data is cleared due to any trouble of the board, it is possible to set an address. In this case, release a protection by entering a password.
- Enter a password “495344”, and press the SIZE key.



- Enter a MAC address. (Enter the data divided with the period individually.)

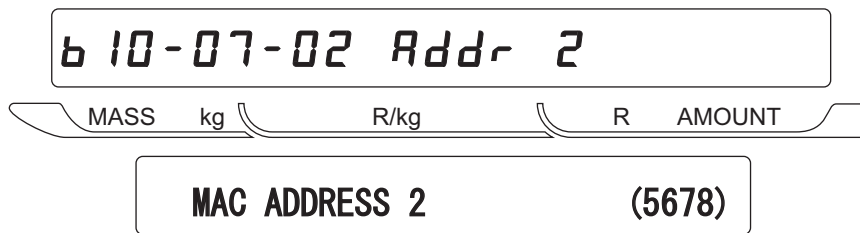

■DHCP SETUP

Data of IP, Gateway, Subnet, and Mask is obtained from the DHCP server.
This cannot be used when not using the DHCP server.

b 10-08 DHCP

MASS kg
R/kg
R AMOUNT

* DHCP SETUP [ENTER]

b 10-08-01 DHCP

MASS kg
R/kg
R AMOUNT

DHCP → 0:DISABLE (0)

Selection 0: Disable 1: Enable

■NETWORK STATUS

6 10-09 5tAeU5
MASS kg R/kg R AMOUNT

* NETWORK STATUS [ENTER]

6 10-09-01 dHCP
MASS kg R/kg R AMOUNT

DHCP STATUS (0)

6 10-09-02 . P
MASS kg R/kg R AMOUNT

IP ADDR. 192.168.10.1

6 10-09-03 nAC
MASS kg R/kg R AMOUNT

MAC ADDR. 00:30:16:15:00:07

6 10-09-04 5Ub
MASS kg R/kg R AMOUNT

SUBNET MASK 0.0.0.0

6 10-09-05 GAt
MASS kg R/kg R AMOUNT

GATEWAY ADDR. 0.0.0.0

Refer to page 4-43 if a communication error occurs.

4.13 System Timer

■SYSTEM TIMER

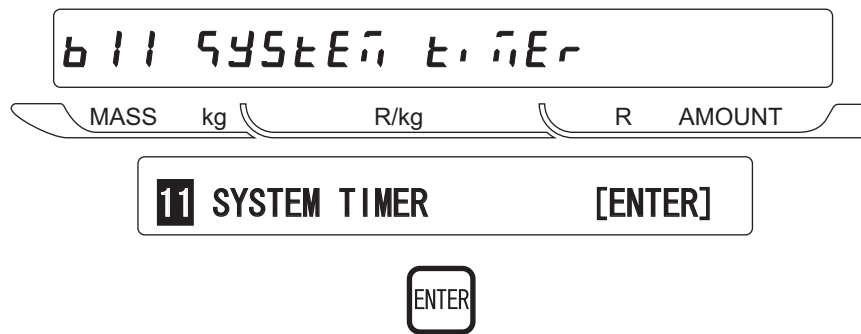

- Set the system timer.

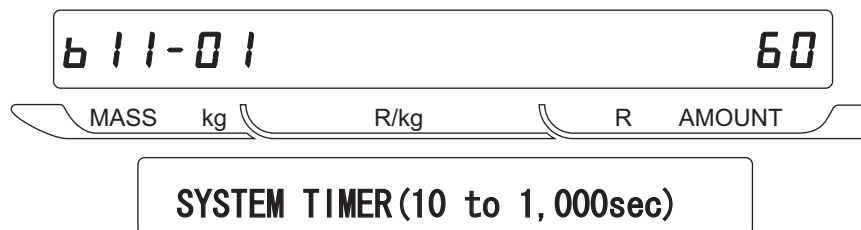

- A function to maintain called data only for a specified time period when there no scale operation is performed in normal mode.
- Time period: 10 to 1,000 seconds (Default: 60 seconds, 1,000 seconds: Not used)

4.14 Password Setup

■PASSWORD

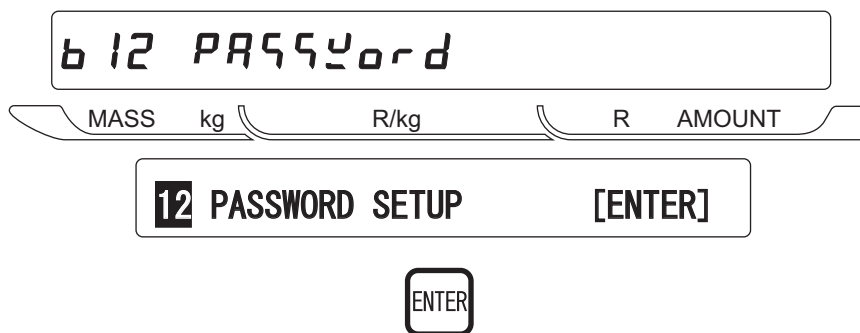

■PASSWORD SETUP

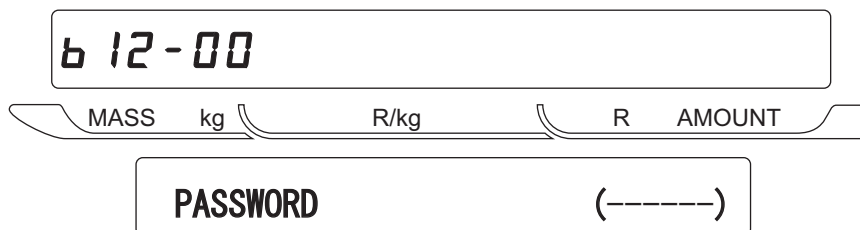

- To enable any mode after B12-01, it is necessary to enter the password. The initial password is "495344". The password can be changed in B12-06.
- Password input
Example: Password "555555"
Enter " 555555 " and press the ENTER key.

■REGISTRATION

Input a password (4 digits) for Registration Mode.

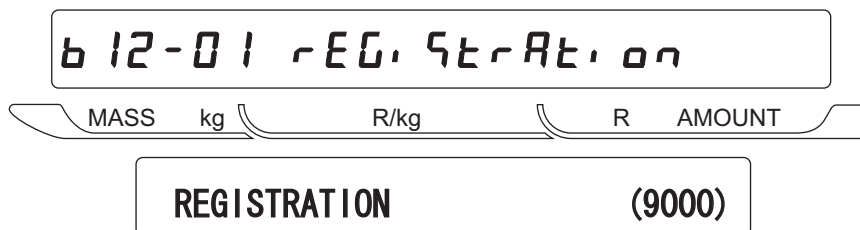

■TOTAL

Input a password (4 digits) for Total Mode.



■SUBTRACTION

Input a password (4 digits) for Subtraction Mode.

b 12-03 SUBTRACT			
MASS	kg	R/kg	R AMOUNT
SUBTRACT			(7000)

■SETUP

Input a password (4 digits) for Setup Mode.

b 12-04 SETUP			
MASS	kg	R/kg	R AMOUNT
SETUP			(6000)

■PASSWORD CHANGE

Change the password to execute B12 mode.

b 12-06			
MASS	kg	R/kg	R AMOUNT
PASSWORD CHANGE			(-----)

0 ... 9 → ENTER

b 12-06			
MASS	kg	R/kg	R AMOUNT
PASSWORD CHECK			(-----)

0 ... 9 → ENTER

4.15 Machine Number Setup

Input a machine number.

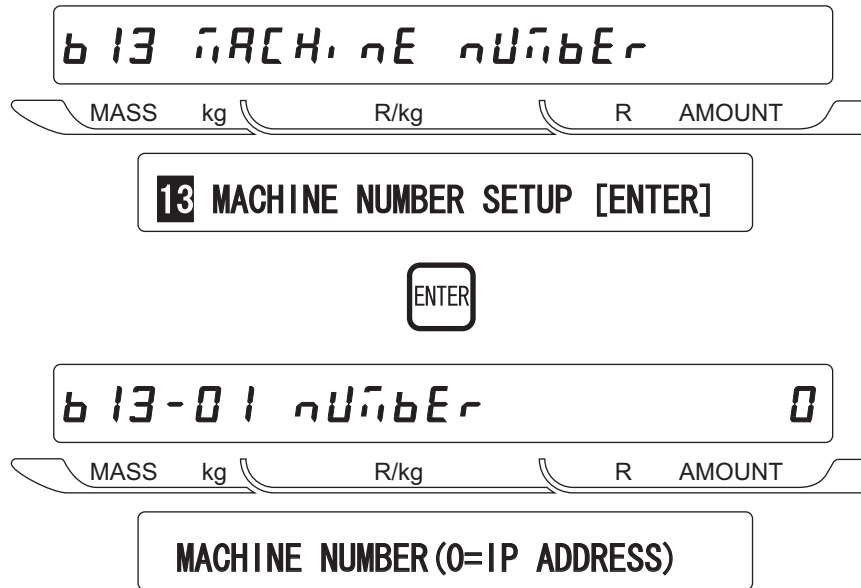

The lower three digits of IP address are referred to.

THECHNICAL REPORT : AC-4000D ONLINE B10-09 FUNCTION

When there s a communication problem in AC-4000D online specification (TCP/IP), please refer the following information order to settle the problem.

B10-09-02 IP ADDRESS
B10-09-03 MAC ADDRESS
B10-09-04 SUBNET MASK
B10-09-05 GATEWAY ADDRESS

B10-09 function

1) When turn on the power (Reset) in ONLINE: set value will be displayed.

B10-09-02 IP ADDRESS = B10-01 IP ADDRESS
B10-09-03 MAC ADDRESS = B10-07 MAC ADDRESS
B10-09-04 SUBNET MASK = B10-03 SUBNET MASK
B10-09-05 GATEWAY ADDRESS = B10-02 GATEWAY ADDRESS

2) When turn on the power (Reset) in OFFLINE:

B10-09-02 IP ADDRESS = default setting (000, 000, 027, 254) will be displayed.
B10-09-03 MAC ADDRESS = default setting (0000, 1bfe, 1001) will be displayed.
B10-09-04 SUBNET MASK = default setting (000, 000, 027, 254) will be displayed.
B10-09-05 GATEWAY ADDRESS = default setting (000, 000, 027, 254) will be displayed.

When default setting is displayed, it means the scale is in OFFLINE.

Please note these B10-09-XX NO. shows the information at “power (Reset) on” so scale dose n otcheck communication status (connect / not connect) in real time.

When communication error (not connect) occurs, please check if the set value is displayed or not in B10-09-02 and B10-09-04.

If set value is not displayed, the scale is in OFFLINE. In this case, please turn ON the scale again (or Reset) and set the scale ONLINE, then check the communication.

If there is any problem or question, please do not hesitate to ask the address of <sc_tec_r@st.ishida.co.jp>.

MEMO

CHAPTER 5 ELECTRICITY COMPOSITION

5.1 Block wiring diagram

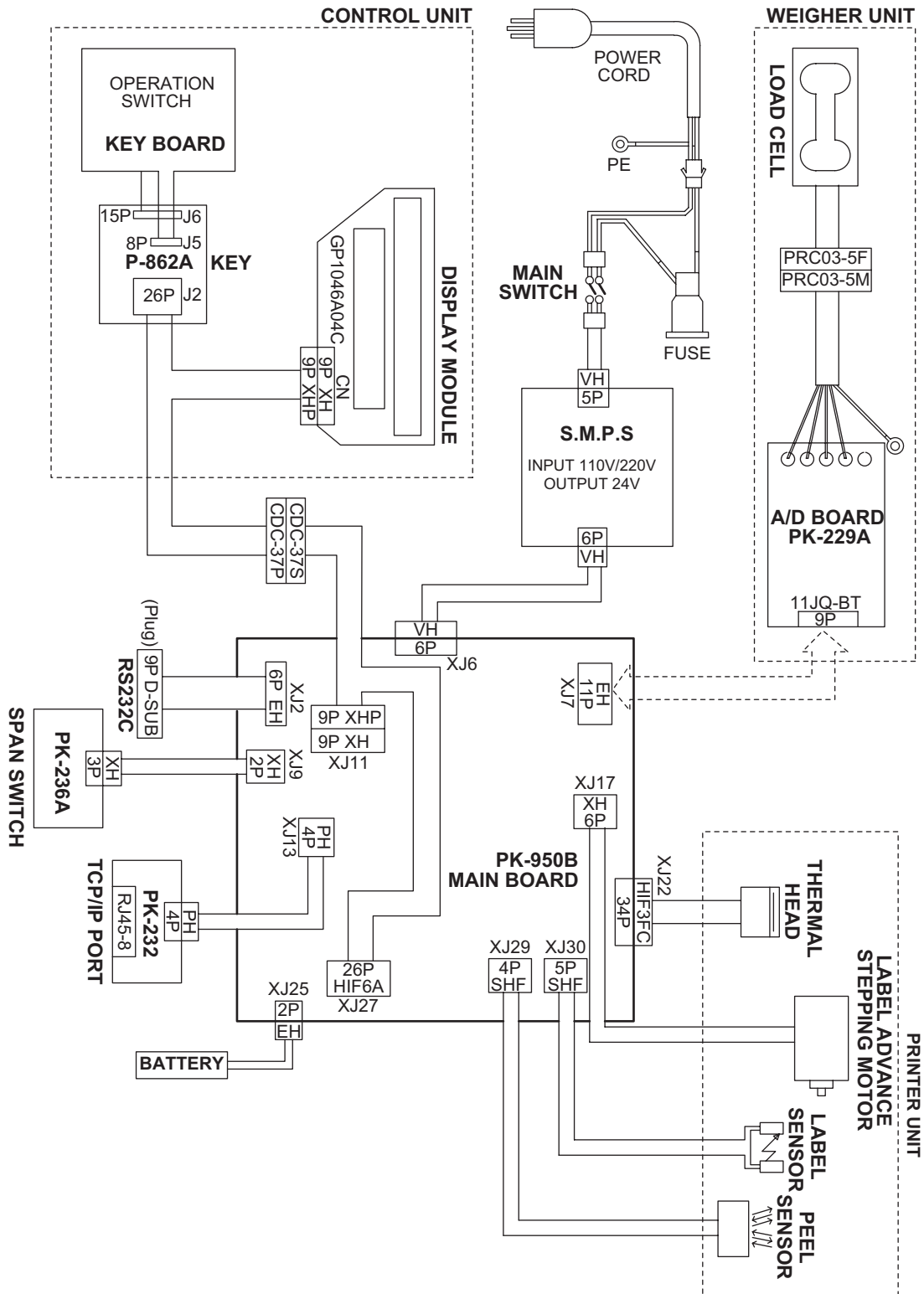

5.2 Main Board [PK-950B]

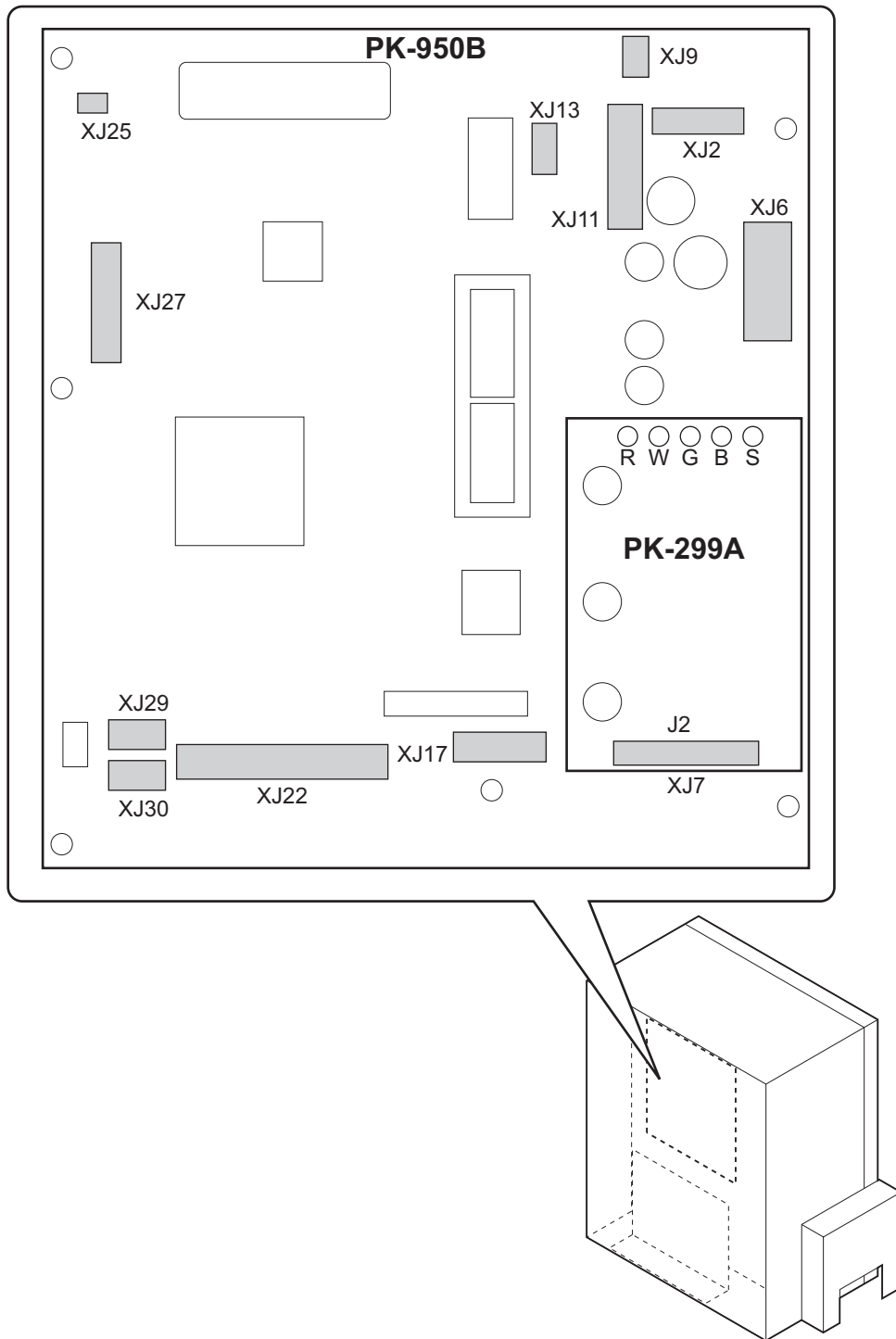

5.3 Connector Specifications

Power supply connector (1)

(XJ6)

Name	B6B-VH		
Pin No.	Function	I/O	Remarks
1	+24V	Power source	
2	+24V	Power source	
3	+24V	Power source	
4	GND	Power source	
5	GND	Power source	
6	GND	Power source	

Ethernet (2)

(XJ13)

Name	B4B-PH-K-S		
Pin No.	Function	I/O	Remarks
1	TX+	Output	
2	TX-	Output	
3	RX+	Input	
4	RX-	Input	

Stepping motor (2)

(XJ17)

Name	B6B-XH-A		
Pin No.	Function	I/O	Remarks
1	A	Output	
2	B	Output	
3	A-	Output	
4	B-	Output	
5	+24V	Power source	
6	+24V	Power source	

RS-232C (2)

(XJ2)

Name	B4B-XH-A		
Pin No.	Function	I/O	Remarks
1	R x D	Input	
2	T x D	Output	
3	DTR	Output	
4	GND	Power source	
5	RTS	Output	
6	CTS	Input	

Key board (2)

(XJ27)

Name						HIF6A-26PA-1. 27DSA					
Pin No.		Function		I/O		Pin No.		Function		I/O	
A1		KS0		Power source		B1		KS1		Output	
A2		KS2		Power source		B2		KS3		Output	
A3		KS4		Power source		B3		KS5		Output	
A4		KS6		Power source		B4		KS7		Input	
A5		KD0		Power source		B5		KD1		Input	
A6		KD2		Power source		B6		KD3		Input	
A7		KD4		Power source		B7		KD5		Input	
A8		KD6		Power source		B8		KD7		Input	
A9		KD8		Power source		B9		KD9		Output	
A10		KD10		Power source		B10		KD11		Output	
A11		KD12		Power source		B11		KD13		Output	
A12		KD14		Power source		B12		KD15		Output	
A13		BZR		Output		B13		VCC		Output	

AC-3000 type VFD display

(XJ11)

Name		B9B-XH-A					
Pin No.		Function		I/O		Remarks	
1		+5V		Power source			
2		GND		Power source			
3		+24V		Power source			
4		GND		Power source			
5		D+		Input/Output			
6		D-		Input/Output			
7		FG		Power source			
8		GND		Power source			
9		RES-		Output			

ASTRA type scale section

(XJ7)

Name		9/11pin stacking connector					
Pin No.		Function		I/O		Remarks	
1		DF_XIN		Power source		Chopping clock	
2		XIN		Output			
3		SDATA		Input/Output			
4		SCK		Output			
5		GND		Power source		16Bit A/D: CS signal	
6		-					
7		CAL (RES#)		Output			
8		DRDY		Input			
9		GND		Power source			
10		+24V/+12V		Power source			
11		-					

Span memory switch connector

(XJ9)

Name	B2B-XH-A		
Pin No.	Function	I/O	Remarks
1	Span SW	Input	
2	GND	Power source	

Peel sensor

(XJ29)

Name	B4P-SHF-1AA		
Pin No.	Function	I/O	Remarks
1	LED+	Output	
2	GND	Power source	
3	+5V	Power source	
4	SENS	Input	

Label sensor

(XJ30)

Name	B5P-SHF-1AA		
Pin No.	Function	I/O	Remarks
1	+5V	Power source	
2	LED+	Output	
3	GND	Power source	
4	SENS	Input	
5	-		

2inch Thermal head

(XJ22)

Name	HIF3FC-30PA-2.54DSA				
Pin No.	Function	I/O	Pin No.	Function	I/O
1	GND	Power source	16	-(History)	Output
2	VH (PchFET)	Power source	17	-(History)	Output
3	GND	Power source	18	DATA	Output
4	VH (PchFET)	Power source	19	TH1	Input
5	GND	Power source	20	TH2	Input
6	VH (PchFET)	Power source	21	RIO0	Input
7	GND	Power source	22	RIO1	Input
8	VH (PchFET)	Power source	23	RIO2	Input
9	GND	Power source	24	-(History)	Output
10	VH (PchFET)	Power source	25	ENABLE1	Output
11	GND	Power source	26	-(History)	Output
12	+5V	Power source	27	-(History)	Output
13	DATA	Output	28	ENABLE2	Output
14	CLOCK	Output	29	-(History)	Output
15	LATCH	Output	30	-(History)	Output

Battery

(XJ25)

Name	B2P-SHF-1AA		
Pin No.	Function	I/O	Remarks
1	BAT (+3V)		
2	GND		

5.4 PK-229A (A/D board)

- The PK-229A (A/D board) is fixed by the two spacers on the PK-950B (Main board), and Five leads of the Load Cell cable are soldered to the PK-229A (A/D board).

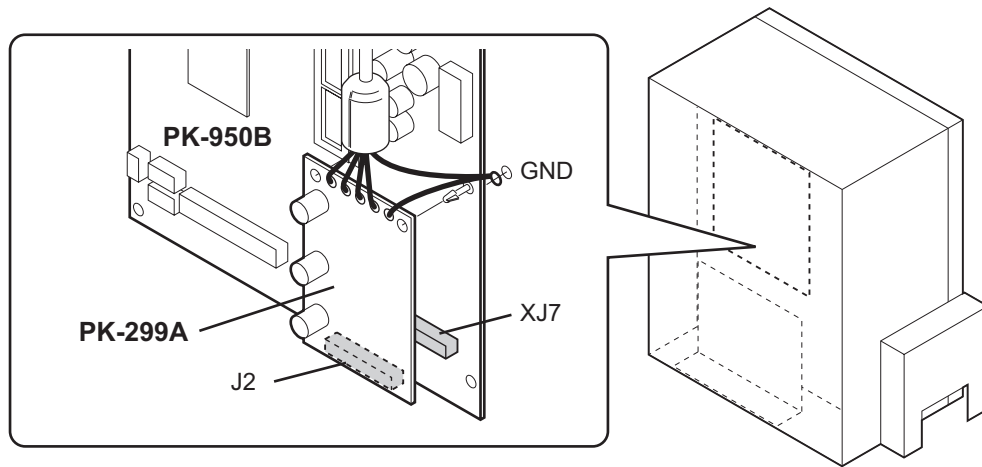

*Note: The load cell output cable and the A/D board (PK-229A) are soldered.
Confirm not to make a mistake in wiring when installed.*

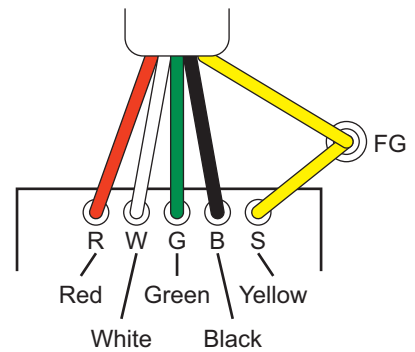

5.5 Lithium Battery

- The battery connector is connected with the PK-950B (XJ25).
To remove the battery, pull out the connector.
- The battery is fixed by a nylon clamping.
To remove the battery, remove the screw (M4 x 10).

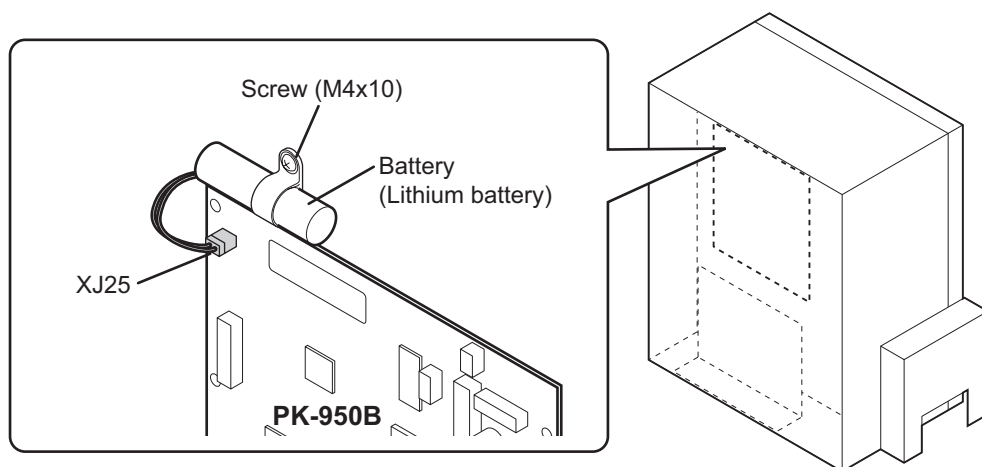

5.6 Power Unit (PB-LSF150-S)

External view

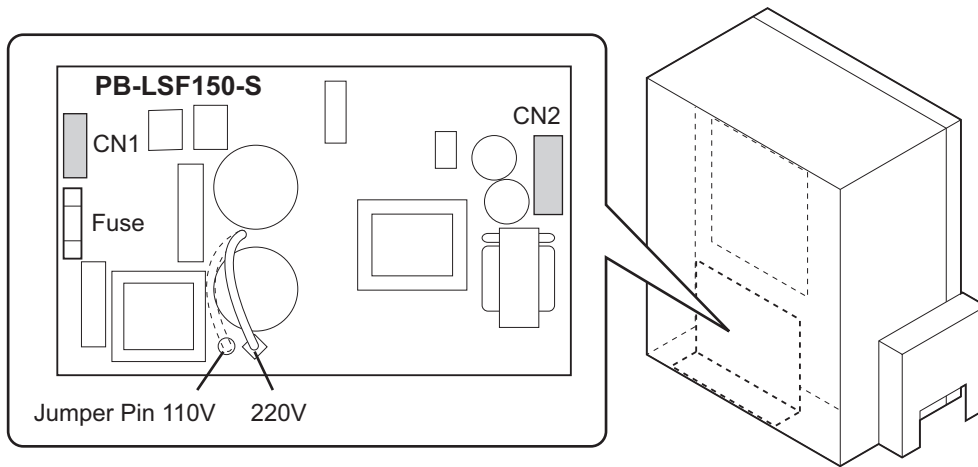

Block diagram

Changing the Power Supply Unit

Voltage	110V	89-2760-03	LSF100-24S
	220V	89-2771-09	LSF100-24S

110V and 220V can be changed by switching over Jumper Pin on PB-LSF150-S

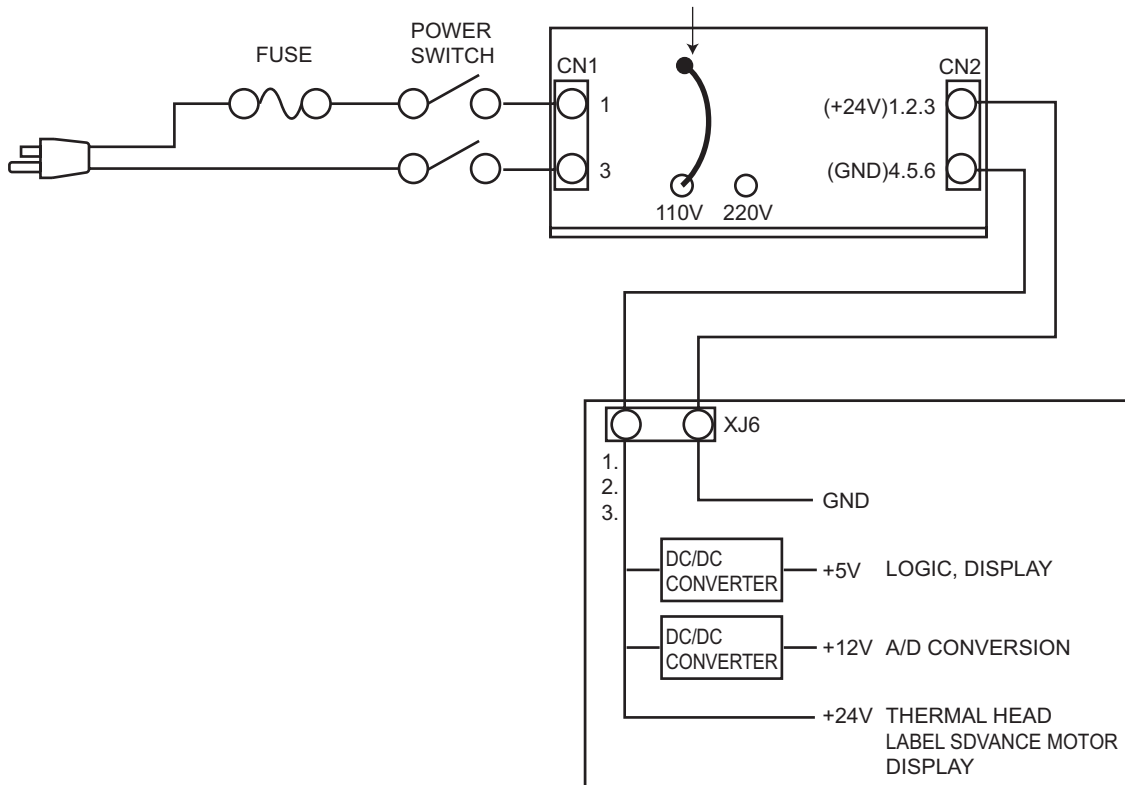

5.7 PK-232 (TCP/IP)

Connecting LAN cable

When connecting the LAN cable, securely insert the connector into the LAN port until it clicks.

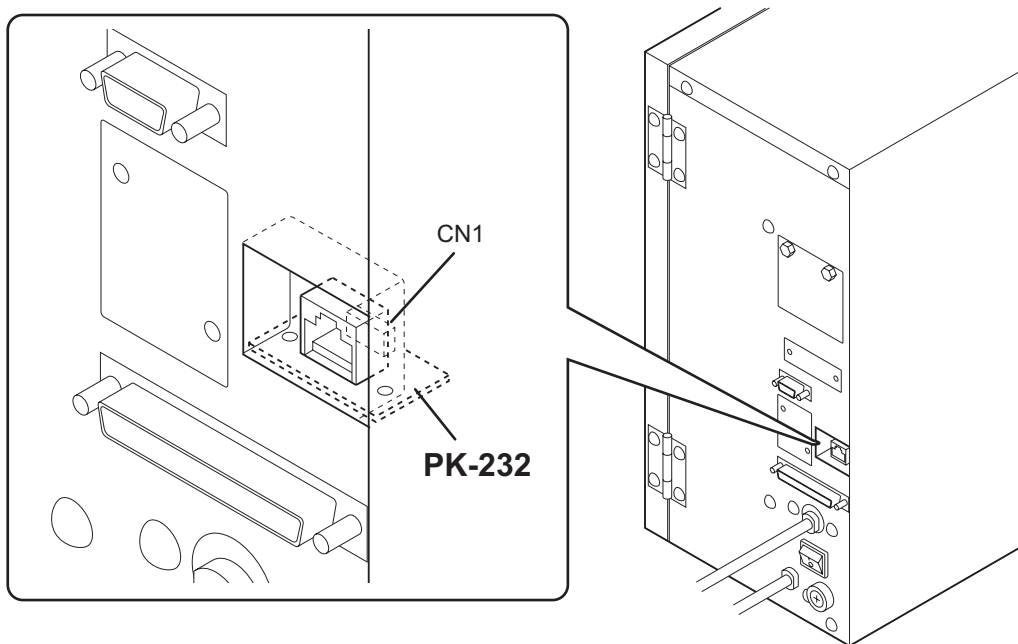

Cable connection method

- Use a crossing cable for connecting the PC and the AC-4000D.
- Use a straight cable for connecting the PC, Hub, and the AC-4000D.

Ethernet Port

PK-950B supports 10 Mbit Ethernet through an RJ45 connector.

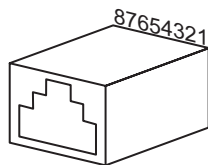

Straight cable

- 1_ Tx+
- 2_ Tx-
- 3_ Rx+
- 4_ not connected
- 5_ not connected
- 6_ Rx-
- 7_ not connected
- 8_ not connected

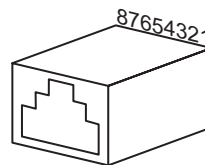

Crossing cable

- 1_ Rx+
- 2_ Rx-
- 3_ Tx+
- 4_ not connected
- 5_ not connected
- 6_ Tx-
- 7_ not connected
- 8_ not connected

5.8 PK-236A (Span switch)

Changed data is cleared when completing this mode unless it is memorized in “E2ROM” by pushing the “Memory Button”.

Note: An authorization test may be required if “A/D DATA” is changed according to the measurement regulations where the machine is used.

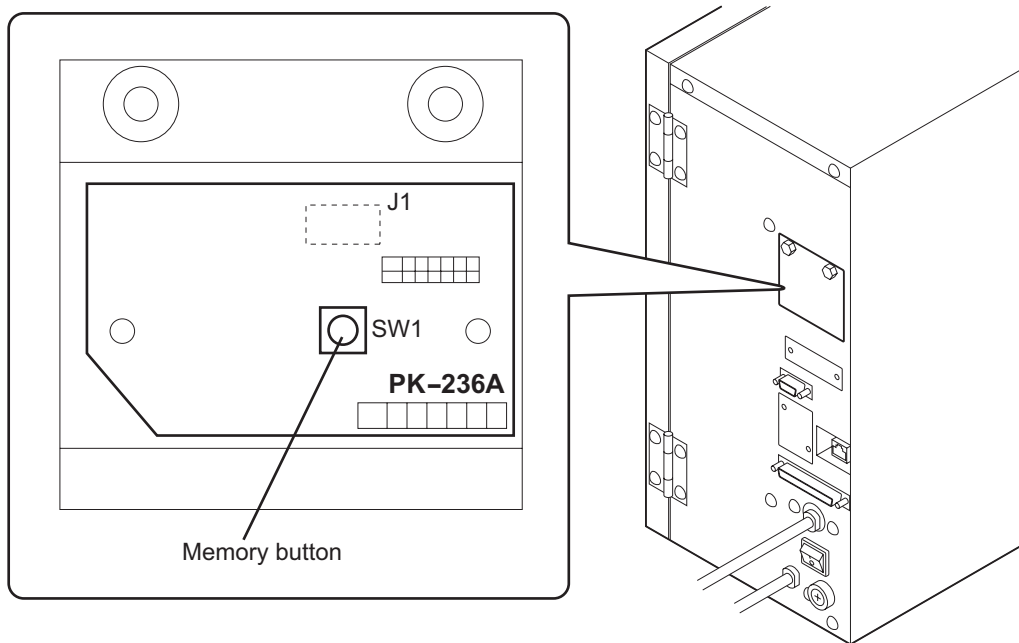

Note: The operation procedure is described in Section 3.4 of Chapter 3.

5.9 P-862A (Key board)

- The P-862A (key board) is built in the display unit.
- Two harnesses are connected from the key sheet to the P-862A (Keyboard).

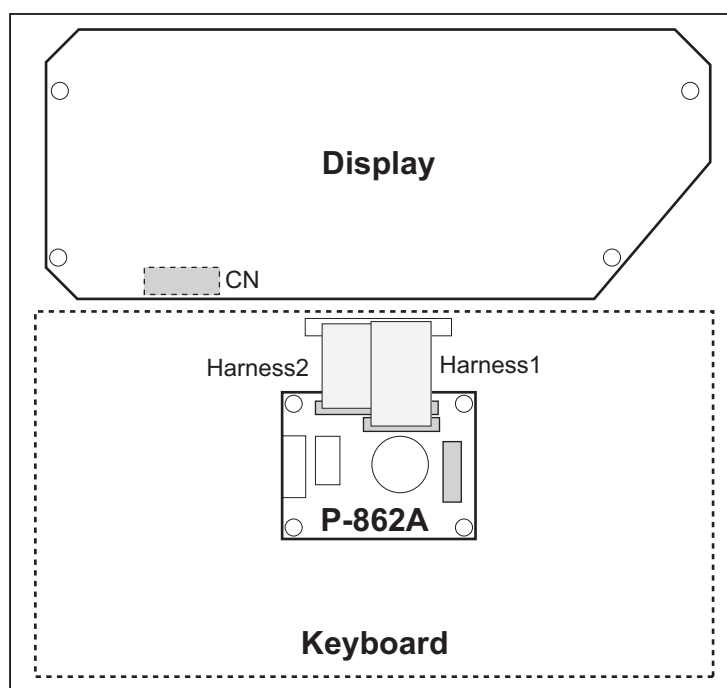

CHAPTER 6 TROUBLESHOOTING

6.1 Error List

Error-2: When ITEM characters exceed the limit number of characters.

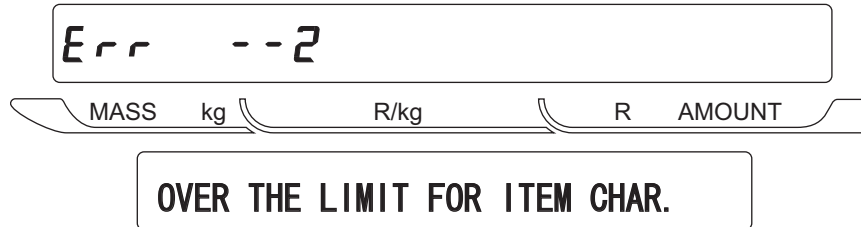

Error-3: When POP MESSAGE exceeds the limit number of characters.

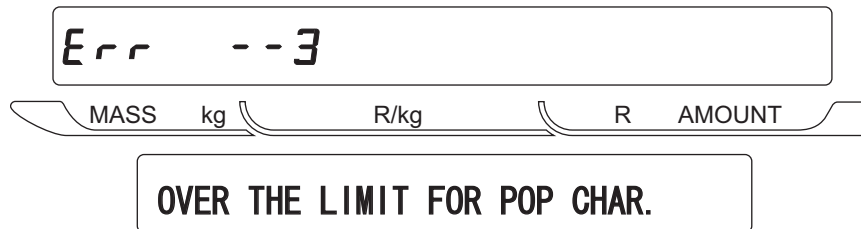

Note: Pressing the CLR key returns to normal mode.

Error-4: When EXTRA MESSAGE exceeds the limit number of characters.

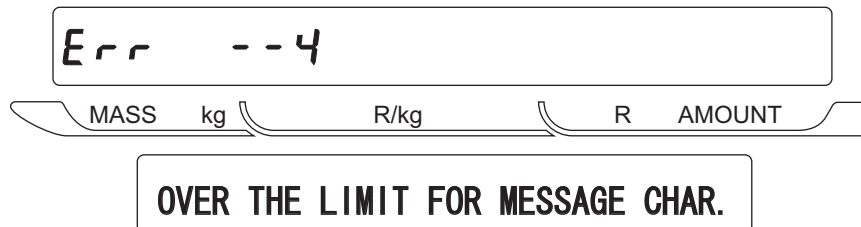

Note: Pressing the CLR key returns to normal mode.

Error-7: When STORE NAME/ADDRESS exceeds the limit number of characters.

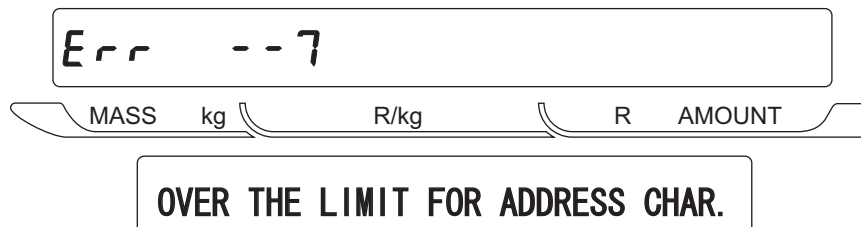

Note: Pressing the CLR key returns to normal mode.

Error-8: When a label paper runs out.

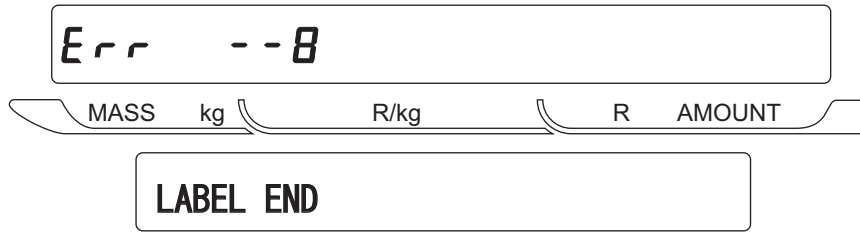

Note: Pressing the CLR key returns to normal mode.

Error-9: When a label size is not suitable.



Note: Pressing the CLR key returns to normal mode.

Error-10: When an error occurs in a discount calculation.

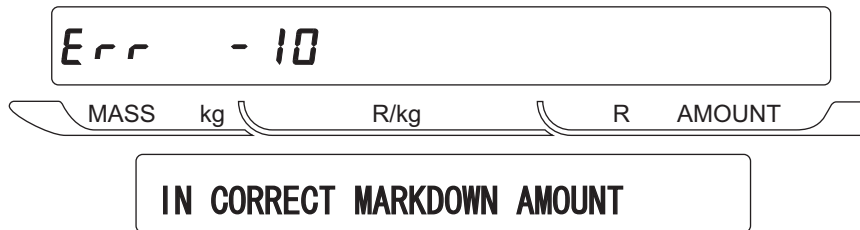

Note: Pressing the CLR key returns to normal mode.

Error-11: When EXTRA MESSAGE 2 exceeds the limit number of characters.



Note: Pressing the CLR key returns to normal mode.

Error-12: When EXTRA MESSAGE 3 exceeds the limit number of characters.

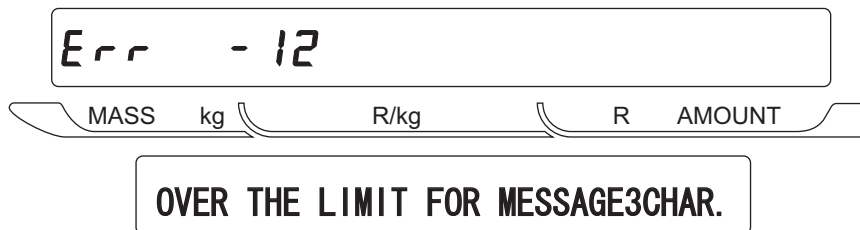

Note: Pressing the CLR key returns to normal mode.

Error-13: When COUPON exceeds the limit number of characters.



Note: Pressing the CLR key returns to normal mode.

Error-16: When actual memory overflows.



Note: Pressing the CLR key returns to normal mode.

Error-21: Thermal head fault error.

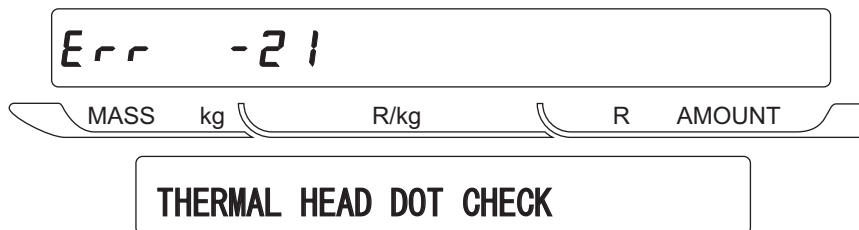

Note: Pressing the CLR key returns to normal mode.

Error-40: When an error occurs in internal memory.

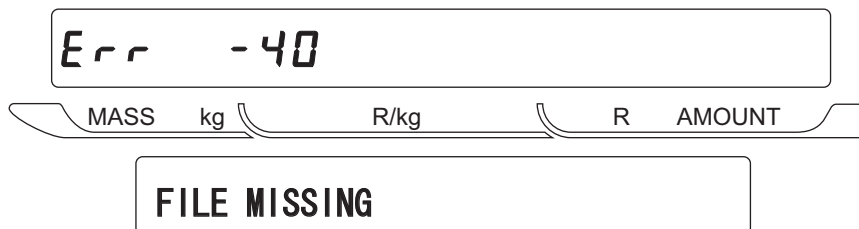

Note: Pressing the CLR key returns to normal mode.

Weight over error : Blank

Weight under error : ----

Over error : Indicated by three beeps.

Display: REMOVE THE ITEM ON THE PLATTER

Remove the item on the weigh platter.

6.2 Symptom, Cause, And Measures

Symptom	Cause	Measures
Power is not applied.	<ol style="list-style-type: none"> 1. Power plug has come off. 2. Fuse burns. 3. Defect of main board (PK-950B) 4. Defect of power supply unit (PB-LSF150-S) 5. Defect of power switch 	<ol style="list-style-type: none"> 1. Insert the power plug. 2. Replace with a new fuse. 3. Replace with a new PK-950B. 4. Replace with a new PB-LSF150-S. 5. Replace with a new power switch.
Turning on power enters test mode.	<ol style="list-style-type: none"> 1. Defect of PK-950B 2. Defect of keyboard switch 	<ol style="list-style-type: none"> 1. Replace with a new PK-950B. 2. Replace with a new keyboard switch.
No further process after display check	<ol style="list-style-type: none"> 1. Defect of load cell 2. Vibration from the outside. 3. Defect of A/D board (PK-229A) 4. Defect of main board (PK-950B) 5. Defect of power supply unit (PB-LSF150-S) 	<ol style="list-style-type: none"> 1. Loading cell adjustment and exchange 2. Confirmation and transfer of installation location 3. Replace with a new PK-229A. 4. Replace with a new PK-950B. 5. Replace with a new PB-LSF150-S.
Weighing margin occurs. (Flickering)	<ol style="list-style-type: none"> 1. Four corners limit screw comes in contact. 2. Foreign obstacle under the load cell. 3. Defect of A/D board (PK-229A) 4. Defect of load cell 5. Defect of main board (PK-950B) 	<ol style="list-style-type: none"> 1. The four corners limit screw is adjusted 2. Removal of foreign body 3. Replace with a new PK-229A. 4. Adjustment and exchange of load cell 5. Replace with a new PK-950B.
Specific segment does not light.	<ol style="list-style-type: none"> 1. The connection is abnormal of the connector. 2. Defect of main board (PK-950B) 3. Defect of display board 	<ol style="list-style-type: none"> 1. The connector connection is confirmed. 2. Replace with a new PK-950B. 3. Replace with a new display board.
A key is not entered.	<ol style="list-style-type: none"> 1. Defect of key sheet 2. Improper connection of connector 	<ol style="list-style-type: none"> 1. Replace with a new key sheet. 2. The connector connection is confirmed.
Registered data changes.	<ol style="list-style-type: none"> 1. Defect of battery 2. Defect of main board (PK-950B) 3. Noise from the outside or influence of static electricity 	<ol style="list-style-type: none"> 1. Replace with a new battery. 2. Replace with a new PK-950B. 3. The installation location is confirmed and transferred.
All the display goes off.	<ol style="list-style-type: none"> 1. Voltage fluctuation 2. Defect of power supply unit (PB-LSF150-S) 3. Defect of display board 4. Defect of main board (PK-950B) 	<ol style="list-style-type: none"> 1. The power-supply voltage is confirmed. 2. Replace with a new PB-LSF150-S. 3. Replace with a new display board. 4. Replace with a new PK-950B.
Print is not carried out.	<ol style="list-style-type: none"> 1. Abnormality of thermal head cable 2. Defect of power supply unit (PB-LSF150-S) 3. Defect of thermal head 4. Defect of main board (PK-950B) 	<ol style="list-style-type: none"> 1. Confirmation of cable 2. Head sign acceptable voltage confirmation PB-LSF150-S exchange 3. Thermal head adjustment and exchange 4. Replace with a new PK-950B.

CHAPTER 7 PARTS REPLACEMENT

7.1 Removing the covers



When disassembling the machine, pull the power plug from the outlet.
If a LAN cable is used for connecting the machine to the external device, disconnect the cable so that the power supply is completely shut off.

■ Removing the main unit cover

1. Cut the seal wire.
2. Remove the two seal screws.
3. Remove the four screws (M4 x 8) from the main unit cover.

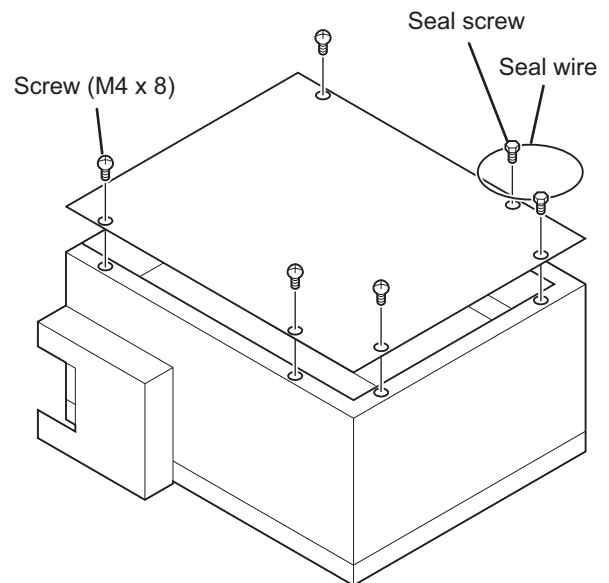

■ Removing the controller unit rear cover

1. Remove the four screws (M4 x 8) from the rear cover.
2. Disconnect the connectors (CM, J2).

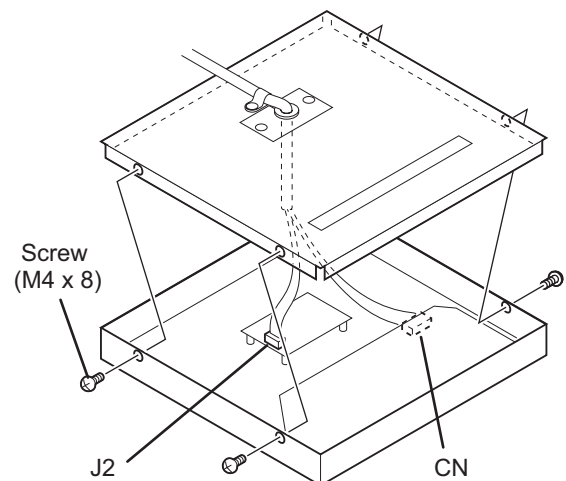

■ Detach the weigh platter

1. Remove the power plug from the main power outlet.
2. Lift the weigh platter horizontally.

Note: The weigh platter is fixed by the 4 pins under the platter inserted in a center of each rubber on the platter holder.

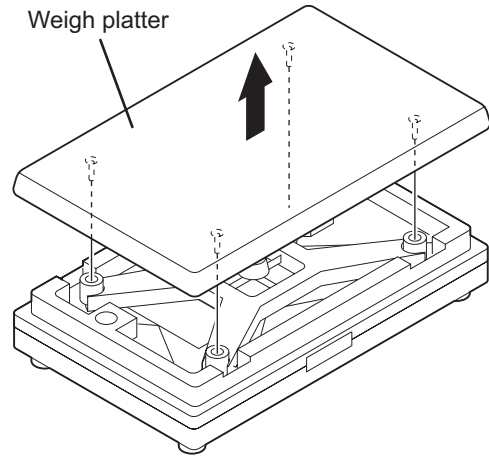

■ Detaching the platter holder

1. Detaching the platter holder by removing the 4 screws (M4 x 12).

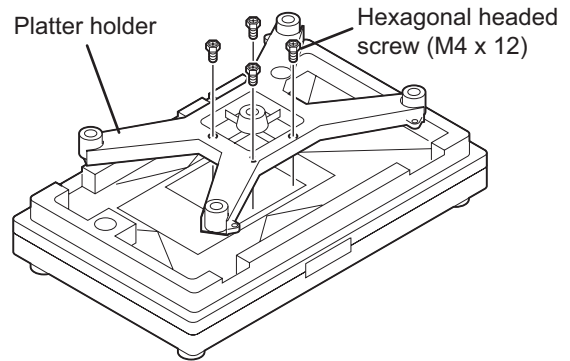

7.2 Detaching Internal Parts

This work must be carried out after finishing preceding section 7.1.

■ Detaching the keyboard relay board (P-862A)

1. Pull out harnesses 1 and 2 of the key sheet from the P-862A.
2. Remove the 4 M4 screws fixing the key relay board (P-862A).

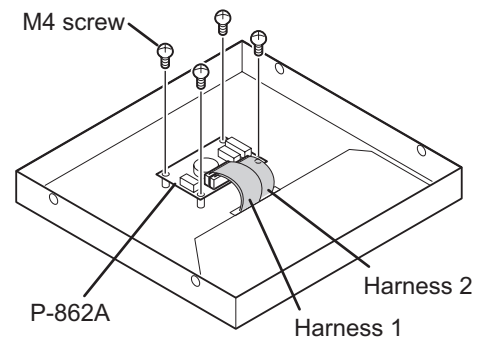

■ Detaching the key sheet

1. Peel off the sheet from the edge of the key sheet.

Note: Care must be paid so as not to damage the main body when peeling off the key sheet.

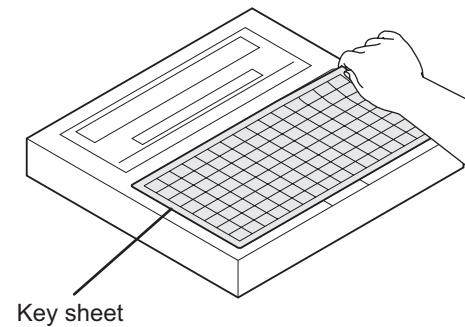

■ Detaching the display

1. Remove the four screws securing the display.

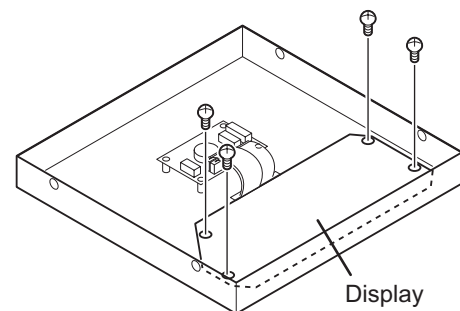

■ Detaching the power supply

1. Pull out the "CN1" and "CN2" connectors.
2. Remove the 2 screws (M4 x 12) on the bottom.

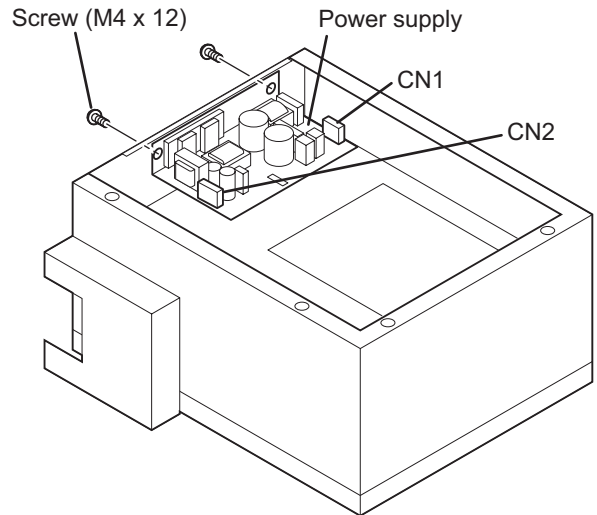

■ Detaching the span switch (PK-236A)

1. Cut the seal wire.
2. Remove the two seal screws to remove the cover.
3. Pull out the PK-236A from card spacers.
4. Pull out the connector of the PK-236A.

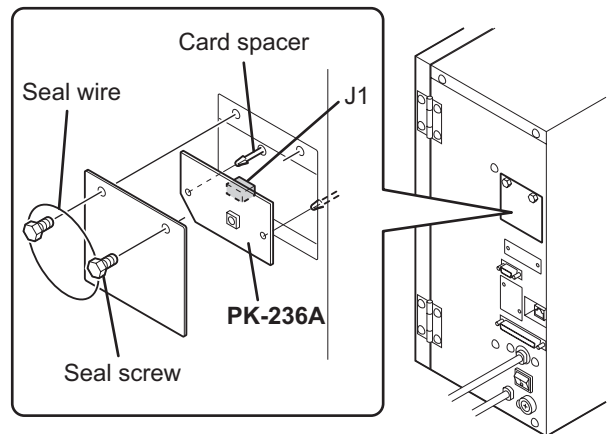

■ Detaching the PK-232 (TCP/IP)

1. Remove the two screws (M3 x 6).

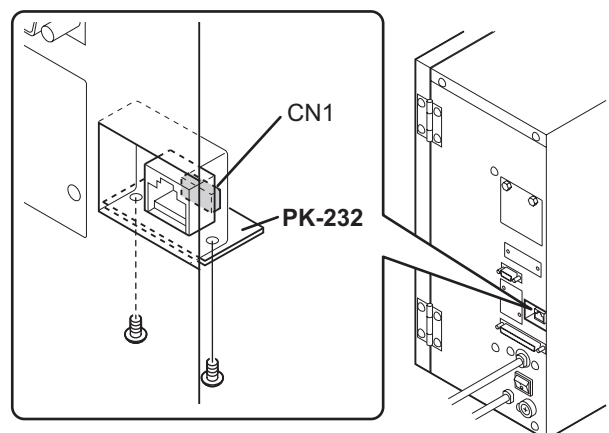

■4-corner limit adjustment

- For the overload from the outside to protect the load cell, this machine has installed the 4 limit screws on the platter holder.

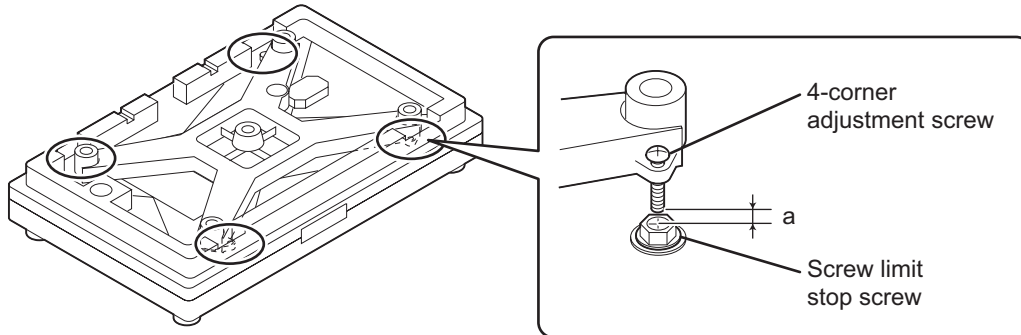

- Adjust the 4 spaces (a) on the platter holder at four corners as shown in the figure below.

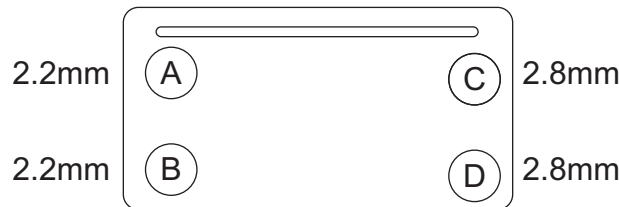

■Detaching the PK-229A (A/D board)

1. Pull out the PK-229A from card spacers.
2. Pull out the PK-229A (J2) and the PK-950B (XJ7) connectors.
3. Remove soldering of the load cell output cable.

Note 1: Perform span adjustment after the PK-229A is exchanged.

2: Check wirings when installing the load cell output cable.

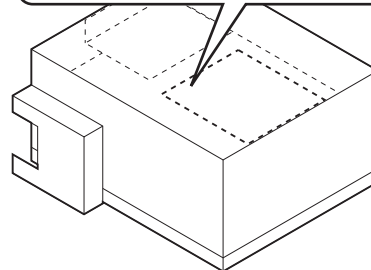
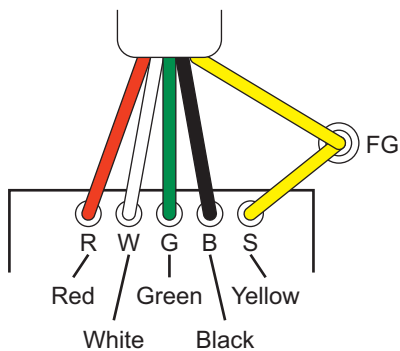
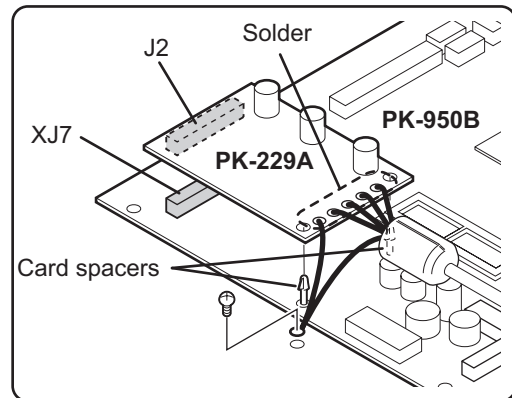

■ Detaching the PK-950B (Main board)

1. Pull out all the harnesses connected with the main board.
2. Remove the two screws (M4 x 6).
3. Remove the board from the 5 card spacers.

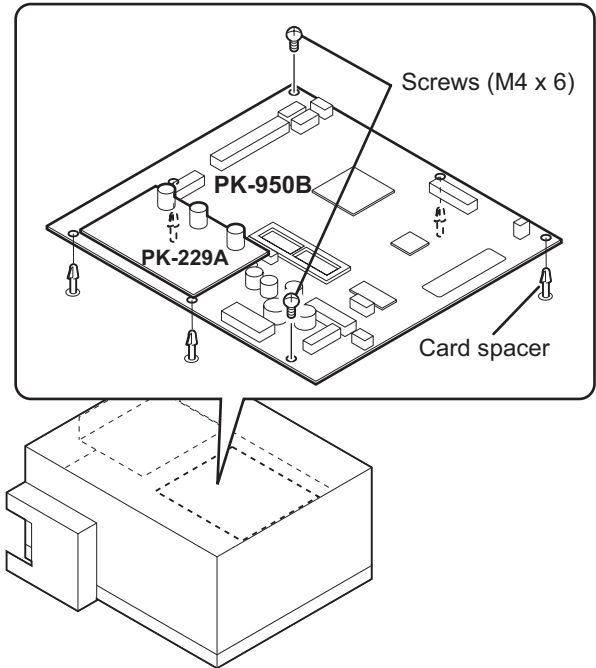

Note 1: Ensure to tighten the 2 screws (M4 x 6) when assembled for establishing a ground.

2: Refer to the previous page for detaching the PK-229A fixed on the PK-950B with a connector.

■ Detaching the thermal head

1. Pull out the thermal (harness) connector.
2. Remove the two screws.

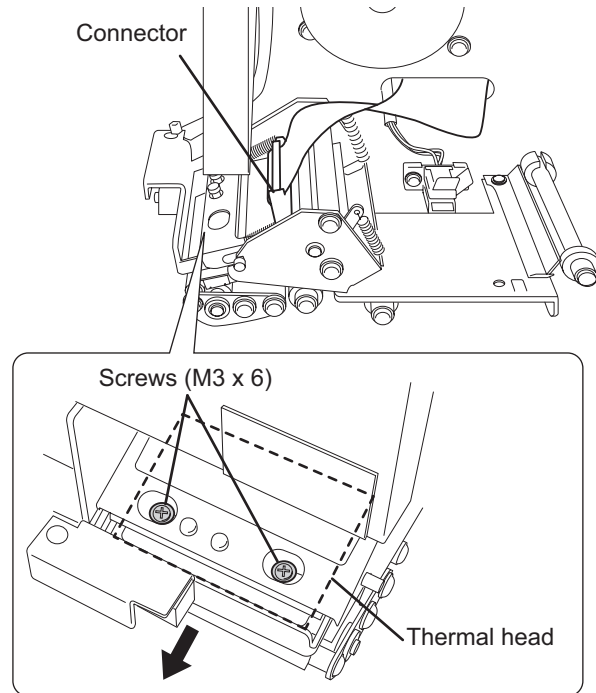
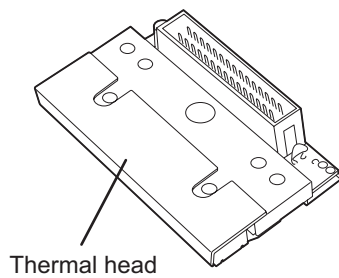

Thermal head specifications

Model	LH3124WH (Double-density thermal head) made by TDK
Total dot number	448 dots
Dot pitch	0.135mm
Head resistance	R=528 to 672 (automatic setting)
Power consumption	0.66W/dot
Applied voltage	24V

Adjusting thermal head print conditions

- Loosen the two screws (M3 x 6) slightly, and move the thermal head back and forth.
- Adjust to match the top point of the print roller with the thermal head applied point.

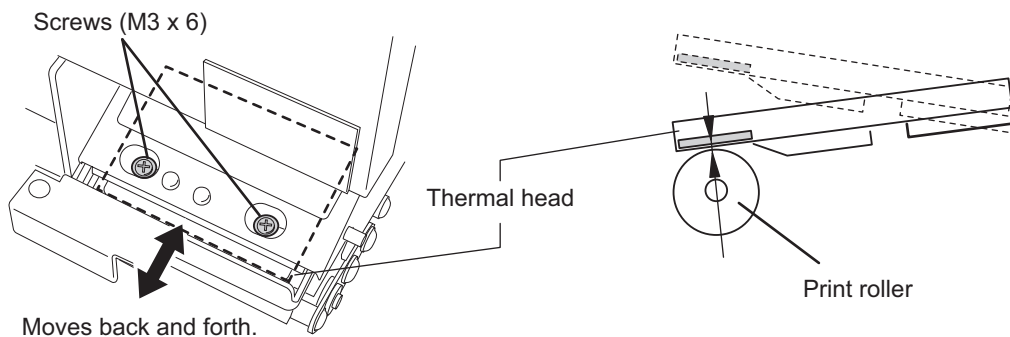

■ **Cleaning the thermal head**

- Clean the thermal head using a cotton swab periodically as shown in the right figure.

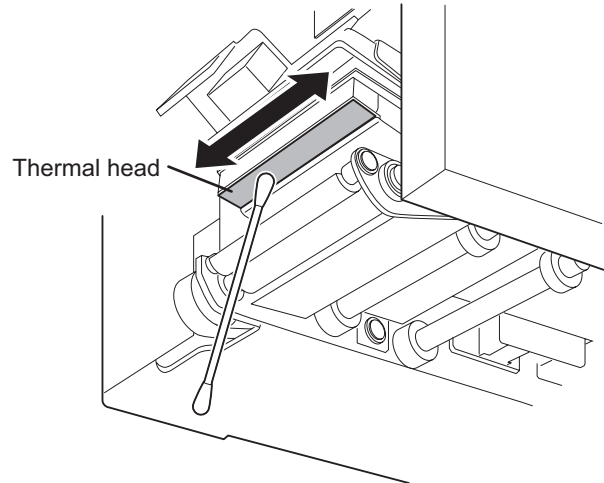

■ **Adjusting the belt tension**

- Remove the four (4) screws and adjust the belt tension by moving the belt motor left or right as shown in the right figure.

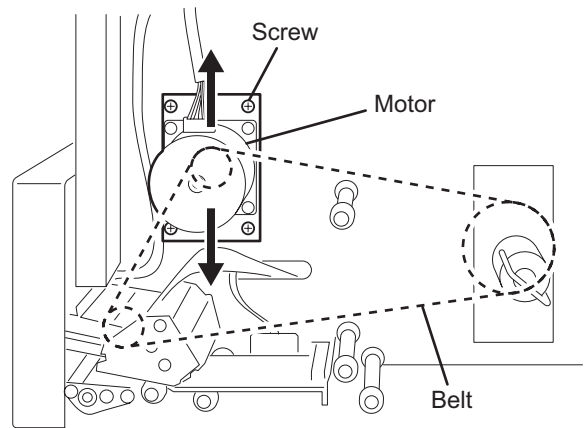

■ **Cleaning the label sensor/peel sensor**

- The label sensor and peel sensor are easily influenced by the environment. Sensitivity may deteriorate due to corrosion caused by dust and moisture outdoors.

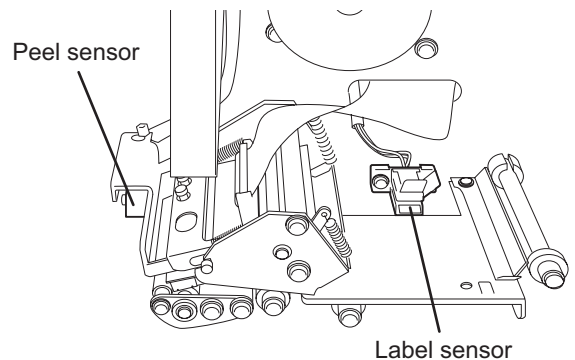

7.3 Periodical Replacement Parts

■ Thermal head (LH3124WH)

Replacement period: Label travel distance 40 to 60km (standard)

Note: The label travel distance varies depending on the label material or thermal head cleaning conditions.

■ Display tube (Display board)

Life: Brightness must be 80% or more of the standard lower bound after lighting for 1,000 hours under the condition of all segments lighting by the standard ratings drive.

Life expectancy: 30,000 hours or more when using it by standard ratings drive.

(Life here is assumed to be a value that the average brightness becomes half of the standard lower bounds.)

■ Print roller

Replacement period: 300km in the travel distance. (standard)

MEMO



Design and specifications are subject to change without notice.

44 SANNO-CHO, SHOGOIN, SAKYO-KU
KYOTO, 606-8392 JAPAN
PHONE: 81-75-771-4141
FACSIMILE: 81-75-751-1634
URL: <http://www.ishidajapan.com>
