

Programming Manual



•

▪

This manual is based on standard specifications. Therefore, application of this manual may depend on the country standards or customer specifications.

You can help to improve this manual by calling attention to errors and by recommending improvements. Please convey your comments to the nearest Ishida Company regional representative. **Thank you!**

Copyright © 1997 by Ishida Co., Ltd. All Rights Reserved.

No part of this manual may be reproduced in any form, by mimeograph or any other means, without written permission of the publisher.



CAUTIONS FOR USE

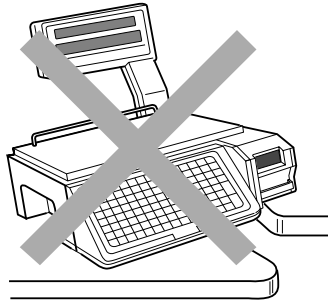

- Always operate the scale on a level surface.

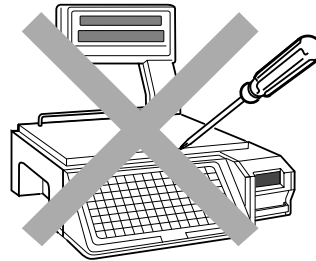

- Do not disassemble the scale.

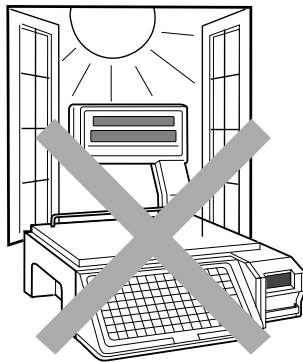

- Do not expose the scale to direct sunlight for long periods.

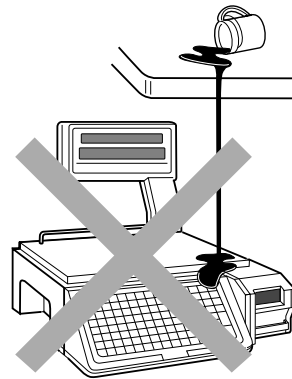

- Do not allow any liquids to come into contact with the scale or terminal.

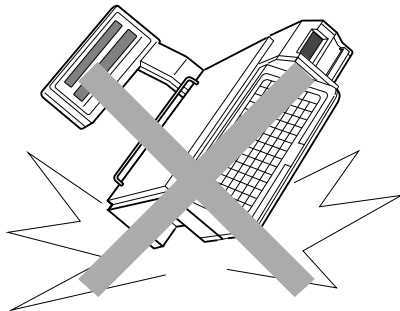

- Do not drop or apply a strong shock to the scale.

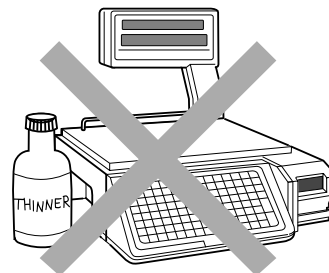

- When cleaning the scale, only use a soft dry cloth or a cloth wetted with a neutral cleanser. Never use thinner or other volatile liquids.

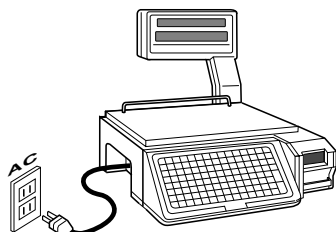

Always operate the scale with the same rated AC power supply shown on the specification plate.



SAFETY CONSIDERATIONS

To ensure safe operation, the general safety considerations below must be followed.

Grounding

This instrument is a Class 1 device which requires protective grounding for safe operation.

To avoid potential shock hazards, a protective grounding conductor for the instrument must be securely connected to the main grounding provision by qualified service personnel.

Do not remove covers or enclosures

To avoid personal injury and shock, do not open or remove any covers or enclosures of the instrument unless specified in the manual.

Do not perform unspecified maintenance

For your personal safety, do not perform any maintenance procedures which are not specified in the manual.

Disconnect power supply before servicing

To ensure your personal safety, disconnect the power supply before servicing.

Contents

Chapter 1: Program Keys

1.1	Program Key Sheet.....	2
1.2	Program Function Keys	3
1.3	Speed Function Keys	4
1.4	Text Editing Keys	5

Chapter 2: Total Reports

2.1	Total Reports	8
2.2	Total Mode	8
2.3	Preset Report	9
2.4	Daily Total Report.....	10
2.5	Weekly Total Report	13
2.6	Monthly Total Report	16
2.7	Hourly Total Report	19
2.8	Periodical Total Report	20
2.9	Operator Total Report.....	21
2.10	Zone Total Report.....	22
2.11	Week Total Report	23
2.12	Total Clear	24
2.13	Daily Total Report (Label)	25

Chapter 3: Programming

3.1	Creating PLUs	28
3.2	Deleting PLUs.....	36
3.3	Price Change File	37
3.4	Extra Message File	41
3.5	Coupon Message File	43
3.6	Date and Time	45
3.7	Store Names and Addresses	46
3.8	Preset Keys	49
3.9	Printing PLU/Message Information	51
3.10	Department Codes and Names	53
3.11	Group Codes and Names	55

3.12 Operator Codes and Names	57
3.13 Advertisement Messages	59
3.14 Campaign Files	62
3.15 Total Barcode	64
3.16 Other Programming	65
3.17 Setting On-line/Off-line	68
3.18 Master File Downloading	69
3.19 Nutrition Files	72
3.20 Changing Unit Price/Fixed Price	78

Chapter 4: Text Editing

4.1 7-Segment Indicators	80
4.2 Character Size	80
4.3 Text Editing Keys	81
4.4 How to Create/Edit Text	82
4.5 How to Reverse/Italic/Underline/Bold Text	83
4.6 How to Insert Characters	85
4.7 How to Change Characters	86
4.8 How to Delete Characters	87

CHAPTER 1

PROGRAM KEYS

Contents

1.1	Program Key Sheet	2
1.2	Program Function Keys	3
1.3	Speed Function Keys	4
1.4	Text Editing Keys	5

1.1 Program Key Sheet

The Program Key Sheet is accessed by removing the Operation Key Sheet. The keys will function as indicated on the following page when one of the following modes has been accessed. This is done by using a password in conjunction with the MODE key.

- Total Report Mode (Chapter 2)
- Programming Mode (Chapter 3)

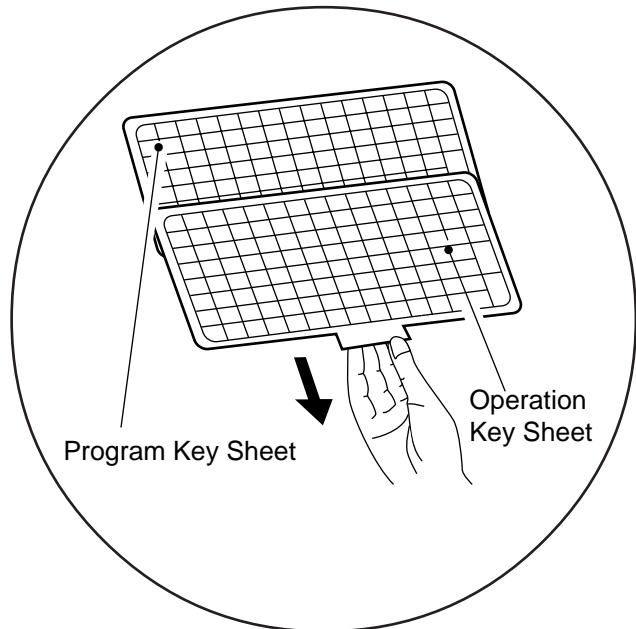
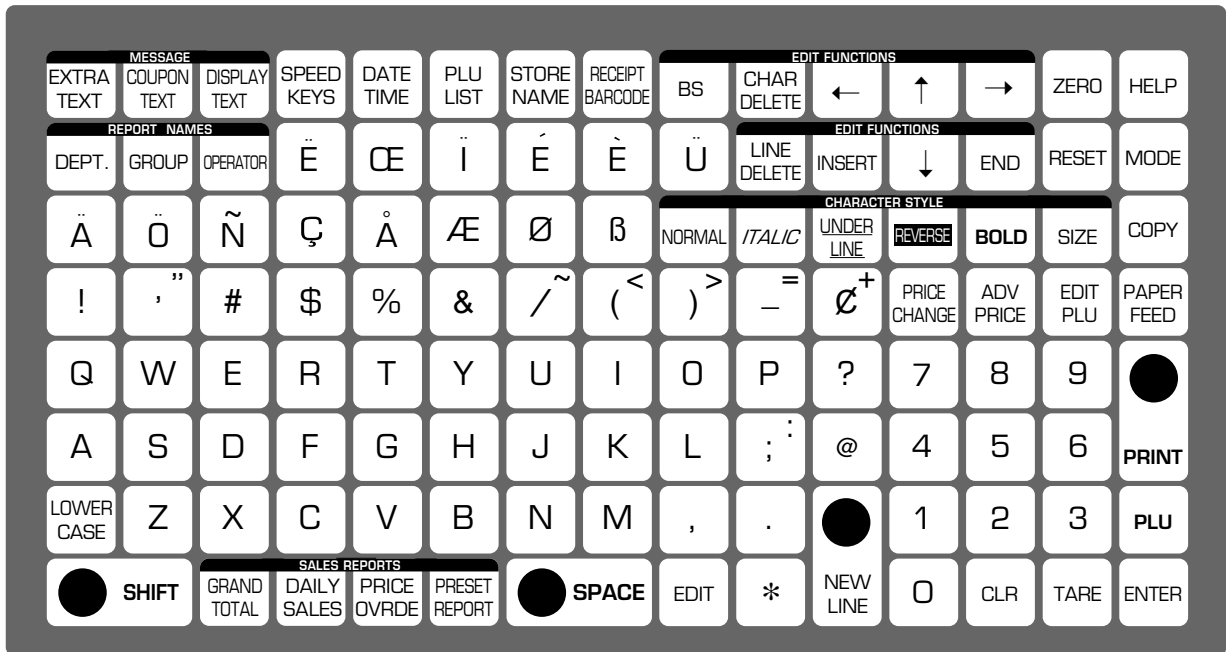

Remove the Operation Key Sheet so that the Program Key Sheet under it can be used.

1.2 Program Function Keys



MODE

Used to access the program, subtraction and total modes after 1 - 4 digit password has been entered. Also used to exit the selected mode.



PRINT

Used to obtain a sample label to confirm the entered text.



CLEAR

Used to return numeric values that have been entered incorrectly to zero.



PAPER FEED

Used to advance labels/receipts to the correct printing position.



PLU

Used to enter specific item numbers such as PLU numbers and message numbers.



END

Used to complete data entry in the program menu and return to the main menu.



ENTER

Used to store numeric entries after the value has been correctly entered. Also used to move up the menu items presented in the program mode, total mode and other menu screens.

1.3 Speed Function Keys

On the Program Key Sheet, there are various Speed Keys to jump directly to programming options. These Speed Keys reduce the dependence on the manual as they give direct access to menu items.

SPEED KEYS

SPEED KEYS

Used to select the menu item for programming the preset keys.

DEPT.

DEPARTMENT

Used to select the menu item for creating, editing or deleting the department name for use in total reports.

DATE TIME

DATE/TIME

Used to select the menu item for programming the date and time.

GROUP

GROUP

Used to select the menu item for creating, editing or deleting the group name for use in total reports.

PLU LIST

PLU LIST

Used to select the menu item for generating a PLU, coupon, campaign and extra text messages file list. The file can be printed on labels/receipts.

OPERATOR

OPERATOR

Used to select the menu item for creating, editing or deleting the operator name.

STORE NAME

STORE NAME

Used to select the menu item for programming store names and address.

GRAND TOTAL

GRAND TOTAL

Used to quickly print the daily department total while in the total mode.

EDIT PLU

EDIT PLU

Used to select the menu item for creating, editing or deleting PLU data.

DAILY SALES

DAILY SALES TOTAL

Used to quickly print the daily terminal total while in the total mode.

EXTRA TEXT

EXTRA TEXT

Used to select the menu item for creating, editing or deleting extra messages.

PRICE OVRDE

PRICE OVERRIDE TOTAL

Used to quickly print all items with changed unit prices while in the total mode. (available only for the operator system)

COUPON TEXT

COUPON TEXT

Used to select the menu item for creating, editing or deleting coupon text messages.

PRESET REPORT

PRESET REPORT

Used to quickly print all preset reports at one time while in the total mode.

DISPLAY TEXT

DISPLAY TEXT

Used to select the menu item for creating, editing or deleting display text messages.

ADV. PRICE

ADVERTISEMENT PRICE

Used to change the unit price or fixed price of the campaign file for the specified PLUs.

RECEIPT BARCODE

RECEIPT BARCODE

Used to program the barcode which is printed on a subtotal label/receipt.

PRICE CHANGE

PRICE CHANGE

Used to change the PLU unit price or fixed-price.

1.4 Text Editing Keys

Use the following Text Editing keys (located on the Program Key Sheet) when creating, editing or deleting text.

Alpha-numeric Keys

The Program Key Sheet comes with a typewriter style keyboard to enter data into fields available.



SHIFT

Used to access the upper character of keys with two characters.
Used with the arrow keys to quickly move to the beginning or end of a PLU description line.



LOWER CASE

Used to change upper or lower case characters.
Available for front size 1 only (smallest).

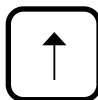

UP ARROW

Used to move the cursor up one line and over to the left margin. Also used to move up the cursor several lines at one time by first pressing the SHIFT key, then entering the number of lines.

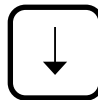

DOWN ARROW

Used to move the cursor down one line and over to the left margin. Also used to move down the cursor several lines at one time by first pressing the SHIFT key then entering the number of lines.

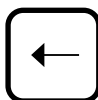

LEFT ARROW

Used to move the cursor one space to the left.

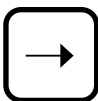

RIGHT ARROW

Used to move the cursor one space to the right.



EDIT

Used to enter the text entry mode for any text field.



NEW LINE

Used as a carriage return when in the text edit mode.



BACK SPACE

Used to delete the last entered character.



CHARACTER DELETE

Used to delete the character where cursor is placed on the display from text field.



LINE DELETE

Used to delete an entire line from text field.



INSERT

Used to change between inserting or overriding characters in editing of any text field.



NORMAL

Used to return to normal type (character size remains unchanged).



ITALIC

Used to switch to italic type.
Also used to return italic type to normal type.



UNDERLINE

Used to switch to underline type.
Also used to return underline type to normal type.



REVERSE

Used to switch to reverse type.
Also used to return reverse type to normal type.



BOLD

Used to switch to bold type.
Also used to return bold type to normal type.



SIZE

Used in combination with the UP ARROW or DOWN ARROW key to select character sizes.



COPY

Used to copy messages such as product name, extra message, and coupon message etc.



WORD WRAP

Used to select primary or secondary word wrap width when using a PLU message or extra text message.

CHAPTER 2

TOTAL REPORTS

Contents

- 2.1 Total Reports 8
- 2.2 Total Mode 8
- 2.3 Preset Report 9
- 2.4 Daily Total Report 10
 - 2.4.1 Daily Report Categories 10
 - 2.4.2 Operation Procedure 11
- 2.5 Weekly Total Report 13
 - 2.5.1 Weekly Report Categories 13
 - 2.5.2 Operation Procedure 14
- 2.6 Monthly Total Report 16
 - 2.6.1 Monthly Report Categories 16
 - 2.6.2 Operation Procedure 17
- 2.7 Hourly Total Report 19
- 2.8 Periodical Total Report 20
- 2.9 Operator Total Report 21
- 2.10 Zone Total Report 22
- 2.11 Week Total Report 23
- 2.12 Total Clear 24
- 2.13 Daily Total Report (Label) 25

2.1 Total Reports

The AC-3000/3000E has the ability to print a large number of reports for the number of labels printed. This information can be broken down into various categories including hourly, daily, weekly and monthly reports.

When the AC-3000/3000E is configured as a Master Satellite system, Total Reports can only be obtained by the Master terminal.

When the AC-3000/3000E is used as a Stand Alone unit, Total Reports except Machine Total can be printed.

Note: Confirm that the Program Key Sheet, and not the Operation Key Sheet, is being used for these operations.

2.2 Total Mode

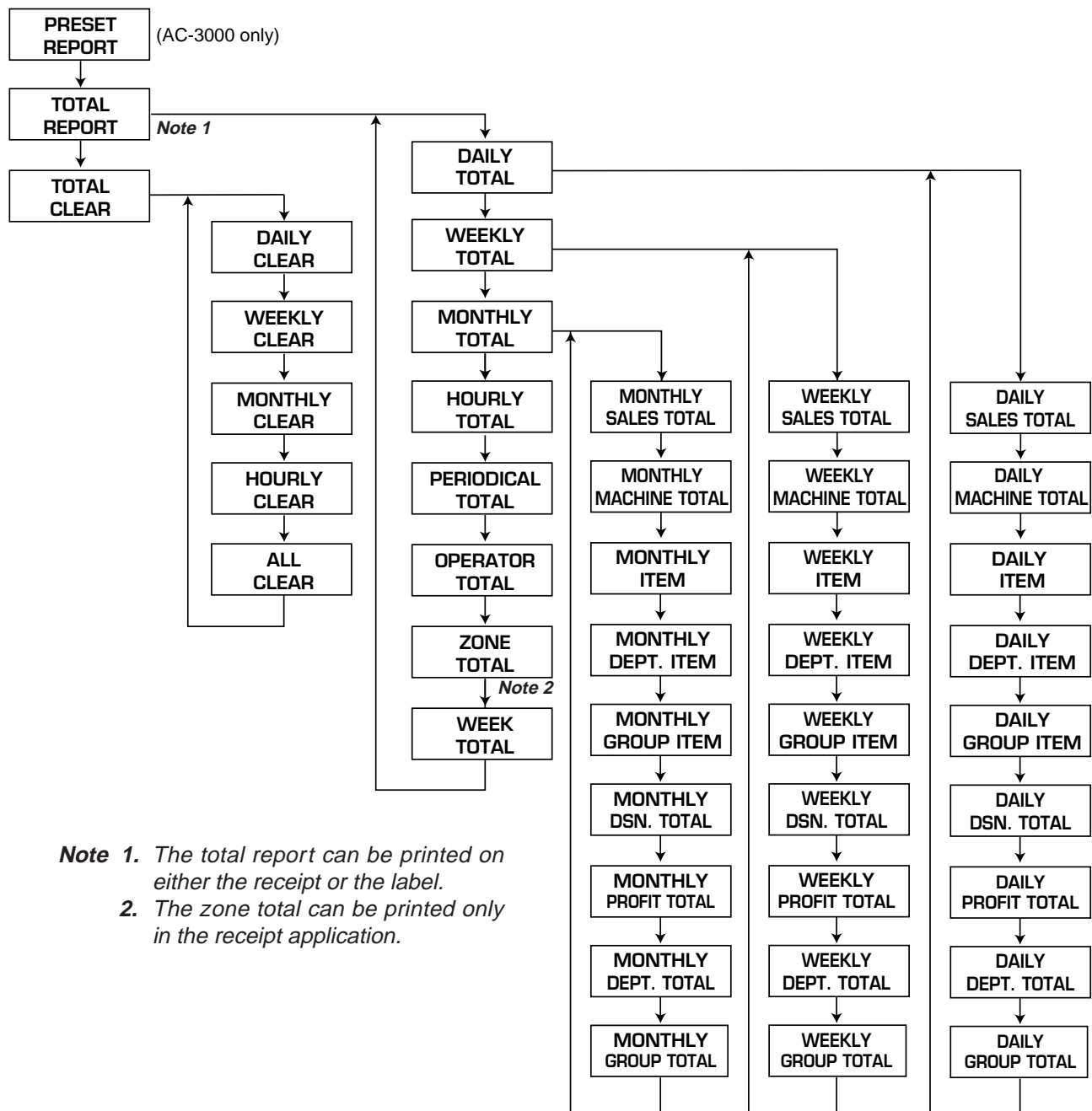



Note 1. The total report can be printed on either the receipt or the label.

Note 2. The zone total can be printed only in the receipt application.

2.3 Preset Report

This report is only available with the AC-3000.

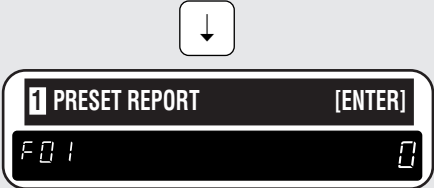
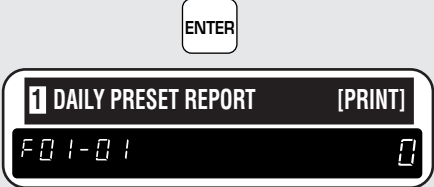
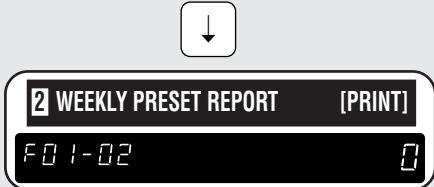
The displays shown below have both a character and a segment display. However, the AC-3000E has only a segment display.

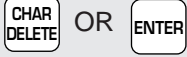
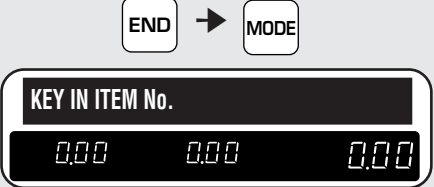
Step	Description	Keys and Display
1	Total Mode <ul style="list-style-type: none"> Enter the password followed by the MODE key to access the Total Mode. <p style="text-align: center;">Example: Password = 8 0 0 0</p>	
2	Preset Report Menu <ul style="list-style-type: none"> Press the DOWN ARROW key to access the Preset Report menu. 	
3	Report Selection <ul style="list-style-type: none"> Press the ENTER key to access the Daily Preset Report printing mode. <p style="text-align: center;">F01-01 = Daily Preset Report</p> <ul style="list-style-type: none"> Press the DOWN ARROW key to access the Weekly Preset Report printing mode. <p style="text-align: center;">F01-02 = Weekly Preset Report</p>	 
4	Print <ul style="list-style-type: none"> Press the PRINT key. <p>Note: Printing will be stopped if the PRINT key is pressed while printing.</p>	
5	Total File Clear <ul style="list-style-type: none"> Press the CHARACTER DELETE key to clear the file, or press the ENTER key to complete report printing without clearing the file. 	 
6	Return to Initial Display <ul style="list-style-type: none"> Press the END key to return to the main menu. Press the MODE key to return to the initial display, if necessary. 	

2.4 Daily Total Report

The Daily Total Report can be considered as the accumulated total for one day. The only difference between this set of total and the weekly or monthly total is the level at which the reports are cleared.

2.4.1 Daily Report Categories

Daily Sales Total Report

The Daily Sales Total Report is the accumulated totals for all items printed since the last time the total was cleared.

Daily Machine Total Report

The Daily Machine Total Report is a list of total for each on-line scale since the last time the total was cleared.

Note: The report will only print when using a Master Satellite configuration.

Daily Item Report

The Daily Item Report is a list of all PLUs that have had labels printed since the last time the total was cleared.

Note: The report will print the total in a desired printing order.

Daily Department Item Report

The Daily Department Item Report is a list of all department items that have had labels printed since the last time the total was cleared.

Note: The report will print the total in a desired printing order.

Daily Group Item Report

The Daily Group Item Report is a list of all group items that have had labels printed since the last time the total was cleared.

Note: The report will print the total in a desired printing order.

Daily Designated PLU Total Report

The Daily Designated PLU Total Report allows the total for a specified PLU to be printed.

Daily Profit Total Report

The Daily Profit Total Report produces a printout indicating how much profit has been made from selling items.

Note: The report will only print when the costs are programmed in the PLUs.

Daily Department Total Report

The Daily Department Total Report groups the PLUs together by the department number programmed for the items. The report lists each department in numeric order.

Note: The report will only print when department numbers are programmed in the PLUs.



Daily Group Total Report

The Daily Group Total Report groups the PLUs together by the group number programmed for the items. The report lists each group in numeric order.

Note: The report will only print when group numbers are programmed in the PLUs.

2.4.2 Operation Procedure

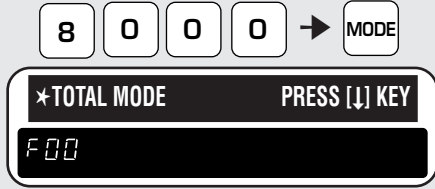
The displays shown below have both a character and a segment display. However, the AC-3000E has only a segment display.

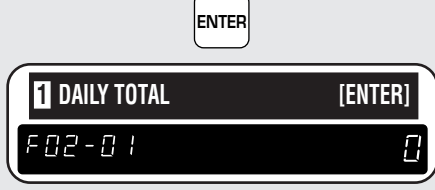
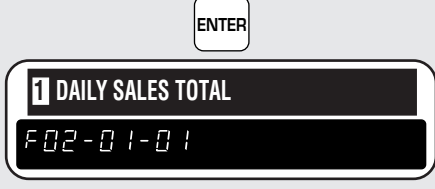
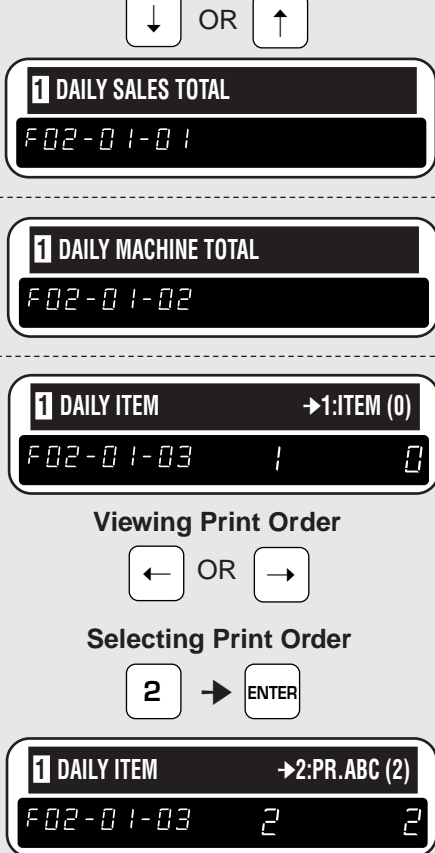
Step	Description	Keys and Display
1	Total Mode <ul style="list-style-type: none"> Enter the password followed by the MODE key to access the Total Mode. Example: Password = 8 0 0 0 	
2	Total Report (Receipt) Menu <ul style="list-style-type: none"> Press the DOWN ARROW key twice to access the Total Report (Receipt) menu. 	
3	Daily Total Menu <ul style="list-style-type: none"> Press the ENTER key to enter the Daily Total menu. 	
4	Report Categories <ul style="list-style-type: none"> Press the ENTER key to access the Report Categories. 	
5	Report Selection <ul style="list-style-type: none"> Use the DOWN ARROW or UP ARROW key to select the desired report. <ul style="list-style-type: none"> F02-01-01 = Daily Sales Total F02-01-02 = Daily Machine Total F02-01-03 = Daily Item <ul style="list-style-type: none"> →1:ITEM Item code order * →2:PR.ABC Amount descending order * →3:WT.ABC Weight descending order * →4:CT.ABC Quantity descending order * →5:PR.Z Amount ascending order * →6:WT.Z Weight ascending order * →7:CT.Z Quantity ascending order <p>Note: Totals with * marks are not available with the AC-3000E.</p> <p>Example: Amount descending order</p>	

Step	Description	Keys and Display
	<ul style="list-style-type: none"> ▪ F02-01-04 = Daily Department Item ▪ F02-01-05 = Daily Group Item ▪ F02-01-06 = Daily Designated PLU Total Example: PLU no. 1 2 3 4 5 6 ▪ F02-01-07 = Daily Profit Total ▪ F02-01-08 = Daily Department Total ▪ F02-01-09 = Daily Group Total 	<div style="border: 1px solid black; padding: 5px; margin-bottom: 10px;"> <p>1 DAILY DEPT. →1:ITEM (0)</p> <p>F02-01-04 1 0</p> </div> <p><i>Note: Select an appropriate printing order.</i></p> <hr style="border-top: 1px dashed black;"/> <div style="border: 1px solid black; padding: 5px; margin-bottom: 10px;"> <p>1 DAILY GROUP →1:ITEM (0)</p> <p>F02-01-05 1 0</p> </div> <p><i>Note: Select an appropriate printing order.</i></p> <hr style="border-top: 1px dashed black;"/> <div style="border: 1px solid black; padding: 5px; margin-bottom: 10px;"> <p>1 DAILY DSN. TOTAL (0)</p> <p>F02-01-06 0</p> </div> <div style="display: flex; justify-content: center; gap: 5px; margin-bottom: 5px;"> 1 2 3 4 5 6 → ENTER </div> <div style="border: 1px solid black; padding: 5px; margin-bottom: 10px;"> <p>1 DAILY DSN. TOTAL (123456)</p> <p>F02-01-06 123456</p> </div> <hr style="border-top: 1px dashed black;"/> <div style="border: 1px solid black; padding: 5px; margin-bottom: 10px;"> <p>1 DAILY PROFIT TOTAL</p> <p>F02-01-07</p> </div> <hr style="border-top: 1px dashed black;"/> <div style="border: 1px solid black; padding: 5px; margin-bottom: 10px;"> <p>1 DAILY DEPARTMENT TOTAL</p> <p>F02-01-08</p> </div> <hr style="border-top: 1px dashed black;"/> <div style="border: 1px solid black; padding: 5px; margin-bottom: 10px;"> <p>1 DAILY GROUP TOTAL</p> <p>F02-01-09</p> </div>
6	Print <ul style="list-style-type: none"> • Press the PRINT key. 	<div style="border: 1px solid black; padding: 5px; width: fit-content; margin: 0 auto;"> PRINT </div>
7	Repeat <ul style="list-style-type: none"> • Repeat steps 5 and 6 for any other reports. 	
8	Return to Initial Display <ul style="list-style-type: none"> • Press the END key to return to the main menu. • Press the MODE key to return to the initial display, if necessary. 	<div style="display: flex; justify-content: center; gap: 10px; margin-bottom: 10px;"> <div style="border: 1px solid black; padding: 2px 5px;">END</div> <div style="border: 1px solid black; padding: 2px 5px;">→</div> <div style="border: 1px solid black; padding: 2px 5px;">MODE</div> </div> <div style="border: 1px solid black; padding: 5px; margin-bottom: 10px;"> <p>KEY IN ITEM No.</p> <p>0.00 0.00 0.00</p> </div>

2.5 Weekly Total Report

The Weekly Total Report can be considered as the accumulated total for one day. The only difference between this set of total and the daily or monthly total is the level at which the reports are cleared.

2.5.1 Weekly Report Categories

Weekly Sales Total Report

The Weekly Sales Total Report is the accumulated totals for all items printed since the last time the total was cleared.

Weekly Machine Total Report

The Weekly Machine Total Report is a list of total for each on-line scale since the last time the total was cleared.

Note: The report will only print when using a Master Satellite configuration.

Weekly Item Report

The Weekly Item Report is a list of all PLUs that have had labels printed since the last time the total was cleared.

Note: The report will print the total in a desired printing order.

Weekly Department Item Report

The Weekly Department Item Report is a list of all department items that have had labels printed since the last time the total was cleared.

Note: The report will print the total in a desired printing order.

Weekly Group Item Report

The Weekly Group Item Report is a list of all group items that have had labels printed since the last time the total was cleared.

Note: The report will print the total in a desired printing order.

Weekly Designated PLU Total Report

The Weekly Designated PLU Total Report allows the total for a specified PLU to be printed.

Weekly Profit Total Report

The Weekly Profit Total Report produces a printout indicating how much profit has been made from selling items.

Note: The report will only print when the costs are programmed in the PLUs.

Weekly Department Total Report

The Weekly Department Total Report groups the PLUs together by the department number programmed for the items. The report lists each department in numeric order.

Note: The report will only print when department numbers are programmed in the PLUs.

Weekly Group Total Report

The Weekly Group Total Report groups the PLUs together by the group number programmed for the items. The report lists each group in numeric order.

Note: The report will only print when group numbers are programmed in the PLUs.

2.5.2 Operation Procedure

The displays shown below have both a character and a segment display. However, the AC-3000E has only a segment display.

Step	Description	Keys and Display
1	Total Mode <ul style="list-style-type: none"> Enter the password followed by the MODE key to access the Total Mode. <p style="text-align: center;">Example: Password = 8 0 0 0</p>	<div style="text-align: center;"> 8 0 0 0 → MODE </div> <div style="border: 1px solid black; padding: 5px; margin-top: 5px;"> ★TOTAL MODE PRESS [↓] KEY </div> <div style="border: 1px solid black; padding: 5px; margin-top: 5px;"> F00 </div>
2	Total Report Menu <ul style="list-style-type: none"> Press the DOWN ARROW key twice to access the Total Report menu. 	<div style="text-align: center;"> ↓ ↓ </div> <div style="border: 1px solid black; padding: 5px; margin-top: 5px;"> 2 TOTAL REPORT [RECEIPT] [ENTER] </div> <div style="border: 1px solid black; padding: 5px; margin-top: 5px;"> F02 </div>
3	Weekly Total Menu <ul style="list-style-type: none"> Enter "2" followed by the ENTER key to select the Weekly Total menu. 	<div style="text-align: center;"> 2 → ENTER </div> <div style="border: 1px solid black; padding: 5px; margin-top: 5px;"> 2 WEEKLY TOTAL [ENTER] </div> <div style="border: 1px solid black; padding: 5px; margin-top: 5px;"> F02-02 </div>
4	Report Categories <ul style="list-style-type: none"> Press the ENTER key to access the Report Categories. 	<div style="text-align: center;"> ENTER </div> <div style="border: 1px solid black; padding: 5px; margin-top: 5px;"> 2 WEEKLY SALES TOTAL </div> <div style="border: 1px solid black; padding: 5px; margin-top: 5px;"> F02-02-01 </div>
5	Report Selection <ul style="list-style-type: none"> Use the DOWN ARROW or UP ARROW key to select the desired report. <ul style="list-style-type: none"> ▪ F02-02-01 = Weekly Sales Total 	<div style="text-align: center;"> ↓ OR ↑ </div> <div style="border: 1px solid black; padding: 5px; margin-top: 5px;"> 2 WEEKLY SALES TOTAL </div> <div style="border: 1px solid black; padding: 5px; margin-top: 5px;"> F02-02-01 </div>
		<div style="border: 1px solid black; padding: 5px; margin-top: 5px;"> WEEKLY MACHINE TOTAL </div> <div style="border: 1px solid black; padding: 5px; margin-top: 5px;"> F02-02-02 </div>
	<ul style="list-style-type: none"> ▪ F02-02-03 = Weekly Item <ul style="list-style-type: none"> →1:ITEM Item code order ★ →2:PR.ABC Amount descending order ★ →3:WT.ABC Weight descending order ★ →4:CT.ABC Quantity descending order ★ →5:PR.Z Amount ascending order ★ →6:WT.Z Weight ascending order ★ →7:CT.Z Quantity ascending order <p>Note: Totals with ★ marks are not available with the AC-3000E.</p> <p>Example: Amount descending order</p>	<div style="border: 1px solid black; padding: 5px; margin-top: 5px;"> 2 WEEKLY ITEM →1:ITEM (0) </div> <div style="border: 1px solid black; padding: 5px; margin-top: 5px;"> F02-02-03 1 </div> <div style="text-align: center; margin-top: 10px;"> Viewing Print Order ← OR → </div> <div style="text-align: center; margin-top: 10px;"> Selecting Print Order 2 → ENTER </div> <div style="border: 1px solid black; padding: 5px; margin-top: 5px;"> 2 WEEKLY ITEM →2:PR.ABC (2) </div> <div style="border: 1px solid black; padding: 5px; margin-top: 5px;"> F02-02-03 2 2 </div>

Step	Description	Keys and Display
	<ul style="list-style-type: none"> ▪ F02-02-04 = Weekly Department Item ▪ F02-02-05 = Weekly Group Item ▪ F02-02-06 = Weekly Designated PLU Total <p style="margin-left: 40px;">Example: PLU no. 1 2 3 4 5 6</p> <ul style="list-style-type: none"> ▪ F02-02-07 = Weekly Profit Total ▪ F02-02-08 = Weekly Department Total ▪ F02-02-09 = Weekly Group Total 	<div style="border: 1px solid black; padding: 5px; margin-bottom: 10px;"> <p>2 WEEKLY DEPT. →1:ITEM (0)</p> <p>F02-02-04 0</p> </div> <p><i>Note: Select an appropriate printing order.</i></p> <hr style="border-top: 1px dashed black;"/> <div style="border: 1px solid black; padding: 5px; margin-bottom: 10px;"> <p>2 WEEKLY GROUP →1:ITEM (0)</p> <p>F02-02-05 1 0</p> </div> <p><i>Note: Select an appropriate printing order.</i></p> <hr style="border-top: 1px dashed black;"/> <div style="border: 1px solid black; padding: 5px; margin-bottom: 10px;"> <p>2 WEEKLY DSN. TOTAL (0)</p> <p>F02-02-06 0</p> </div> <div style="display: flex; justify-content: center; gap: 5px; margin-bottom: 10px;"> 1 2 3 4 5 6 → ENTER </div> <div style="border: 1px solid black; padding: 5px; margin-bottom: 10px;"> <p>2 WEEKLY DSN. TOTAL (123456)</p> <p>F02-02-06 123456</p> </div> <hr style="border-top: 1px dashed black;"/> <div style="border: 1px solid black; padding: 5px; margin-bottom: 10px;"> <p>2 WEEKLY PROFIT TOTAL</p> <p>F02-02-07</p> </div> <hr style="border-top: 1px dashed black;"/> <div style="border: 1px solid black; padding: 5px; margin-bottom: 10px;"> <p>2 WEEKLY DEPARTMENT TOTAL</p> <p>F02-02-08</p> </div> <hr style="border-top: 1px dashed black;"/> <div style="border: 1px solid black; padding: 5px; margin-bottom: 10px;"> <p>2 WEEKLY GROUP TOTAL</p> <p>F02-02-09</p> </div>
6	Print <ul style="list-style-type: none"> • Press the PRINT key. 	<div style="border: 1px solid black; padding: 5px; width: fit-content; margin: auto;"> PRINT </div>
7	Repeat <ul style="list-style-type: none"> • Repeat steps 5 and 6 for any other reports. 	
8	Return to Initial Display <ul style="list-style-type: none"> • Press the END key to return to the main menu. • Press the MODE key to return to the initial display, if necessary. 	<div style="display: flex; justify-content: center; gap: 20px; margin-bottom: 10px;"> <div style="border: 1px solid black; padding: 2px 5px;">END</div> <div>→</div> <div style="border: 1px solid black; padding: 2px 5px;">MODE</div> </div> <div style="border: 1px solid black; padding: 5px; margin: auto;"> <p>KEY IN ITEM No.</p> <p>0.00 0.00 0.00</p> </div>

2.6 Monthly Total Report

The Monthly Total Report can be considered as the accumulated total for one day. The only difference between this set of total and the daily or monthly total is the level at which the reports are cleared.

2.6.1 Monthly Report Categories

Monthly Sales Total Report

The Monthly Sales Total Report is the accumulated totals for all items printed since the last time the total was cleared.

Monthly Machine Total Report

The Monthly Machine Total Report is a list of total for each on-line scale since the last time the total was cleared.

Note: The report will only print when using a Master Satellite configuration.

Monthly Item Report

The Monthly Item Report is a list of all PLUs that have had labels printed since the last time the total was cleared.

Note: The report will print the total in a desired printing order.

Monthly Department Item Report

The Monthly Department Item Report is a list of all department items that have had labels printed since the last time the total was cleared.

Note: The report will print the total in a desired printing order.

Monthly Group Item Report

The Monthly Group Item Report is a list of all group items that have had labels printed since the last time the total was cleared.

Note: The report will print the total in a desired printing order.

Monthly Designated PLU Total Report

The Monthly Designated PLU Total Report allows the total for a specified PLU to be printed.

Monthly Profit Total Report

The Monthly Profit Total Report produces a printout indicating how much profit has been made from selling items.

Note: The report will only print when the costs are programmed in the PLUs.

Monthly Department Total Report

The Monthly Department Total Report groups the PLUs together by the department number programmed for the items. The report lists each department in numeric order.

Note: The report will only print when department numbers are programmed in the PLUs.



Monthly Group Total Report

The Monthly Group Total Report groups the PLUs together by the group number programmed for the items. The report lists each group in numeric order.

Note: The report will only print when group numbers are programmed in the PLUs.

2.6.2 Operation Procedure

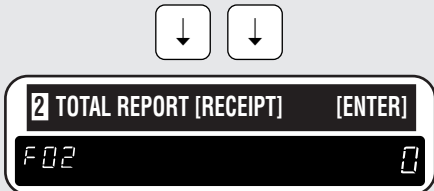
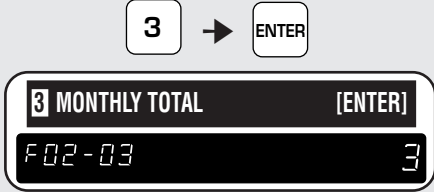
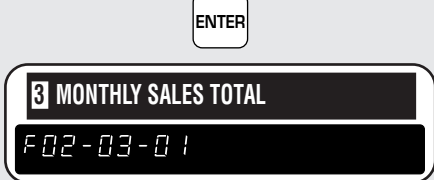
The displays shown below have both a character and a segment display. However, the AC-3000E has only a segment display.

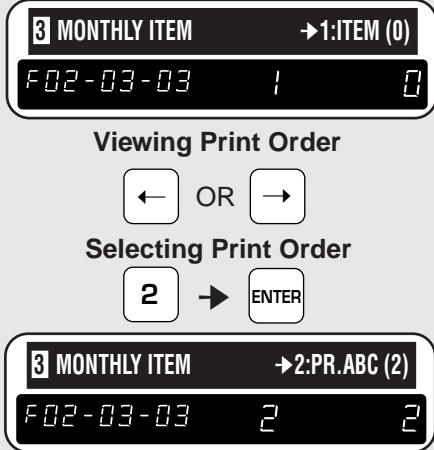

Step	Description	Keys and Display
1	Total Mode <ul style="list-style-type: none"> Enter the password followed by the MODE key to access the Total Mode. <p>Example: Password = 8 0 0 0</p>	
2	Total Report Menu <ul style="list-style-type: none"> Press the DOWN ARROW key twice to access the Total Report menu. 	
3	Monthly Total Menu <ul style="list-style-type: none"> Enter "3" followed by the ENTER key to select the Monthly Total menu. 	
4	Report Categories <ul style="list-style-type: none"> Press the ENTER key to access the Report Categories. 	
5	Report Selection <ul style="list-style-type: none"> Use the DOWN ARROW or UP ARROW key to select the desired report. <p>▪F02-03-01 = Monthly Sales Total</p>	
	<p>▪F02-03-02 = Monthly Machine Total</p>	
	<p>▪F02-03-03 = Monthly Item</p> <ul style="list-style-type: none"> →1:ITEM Item code order * →2:PR.ABC Amount descending order * →3:WT.ABC Weight descending order * →4:CT.ABC Quantity descending order * →5:PR.Z Amount ascending order * →6:WT.Z Weight ascending order * →7:CT.Z Quantity ascending order <p>Note: Totals with * marks are not available with the AC-3000E.</p> <p>Example: Amount descending order</p>	 <p>Viewing Print Order</p> <p>← OR →</p> <p>Selecting Print Order</p> <p>2 → ENTER</p>

Step	Description	Keys and Display
	<ul style="list-style-type: none"> ♦ F02-03-04 = Monthly Department Item ♦ F02-03-05 = Monthly Group Item ♦ F02-03-06 = Monthly Designated PLU Total <li style="padding-left: 40px;">Example: PLU no. 1 2 3 4 5 6 ♦ F02-03-07 = Monthly Profit Total ♦ F02-03-08 = Monthly Department Total ♦ F02-03-09 = Monthly Group Total 	<div style="border: 1px solid black; padding: 5px; margin-bottom: 10px;"> <p>3 MONTHLY DEPT. →1:ITEM (0)</p> <p>F02-03-04 1 0</p> <p><i>Note: Select an appropriate printing order.</i></p> </div> <hr style="border-top: 1px dashed black;"/> <div style="border: 1px solid black; padding: 5px; margin-bottom: 10px;"> <p>3 MONTHLY GROUP →1:ITEM (0)</p> <p>F02-03-05 1 0</p> <p><i>Note: Select an appropriate printing order.</i></p> </div> <hr style="border-top: 1px dashed black;"/> <div style="border: 1px solid black; padding: 5px; margin-bottom: 10px;"> <p>3 MONTHLY DSN. TOTAL (0)</p> <p>F02-03-06 0</p> <p style="text-align: center;">1 2 3 4 5 6 → ENTER</p> <p>3 MONTHLY DSN. TOTAL (123456)</p> <p>F02-03-06 123456</p> </div> <hr style="border-top: 1px dashed black;"/> <div style="border: 1px solid black; padding: 5px; margin-bottom: 10px;"> <p>3 MONTHLY PROFIT TOTAL</p> <p>F02-03-07</p> </div> <hr style="border-top: 1px dashed black;"/> <div style="border: 1px solid black; padding: 5px; margin-bottom: 10px;"> <p>3 MONTHLY DEPARTMENT TOTAL</p> <p>F02-03-08</p> </div> <hr style="border-top: 1px dashed black;"/> <div style="border: 1px solid black; padding: 5px;"> <p>3 MONTHLY GROUP TOTAL</p> <p>F02-03-09</p> </div>
6	Print <ul style="list-style-type: none"> • Press the PRINT key. 	<div style="border: 1px solid black; padding: 5px; width: fit-content; margin: auto;">PRINT</div>
7	Repeat <ul style="list-style-type: none"> • Repeat steps 5 and 6 for any other reports. 	
8	Return to Initial Display <ul style="list-style-type: none"> • Press the END key to return to the main menu. • Press the MODE key to return to the initial display, if necessary. 	<div style="text-align: center; margin-bottom: 10px;"> <div style="border: 1px solid black; padding: 2px 10px; display: inline-block;">END</div> → <div style="border: 1px solid black; padding: 2px 10px; display: inline-block;">MODE</div> </div> <div style="border: 1px solid black; padding: 5px; margin: auto;"> <p>KEY IN ITEM No.</p> <p>0.00 0.00 0.00</p> </div>

2.7 Hourly Total Report

The Hourly Total Report allows the manager to obtain a report that shows totals by the hour. This report can be used to assist with scheduling of employees to meet the busy periods.

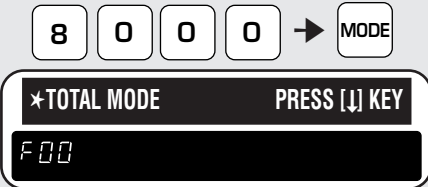
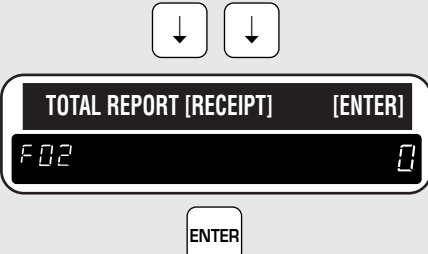
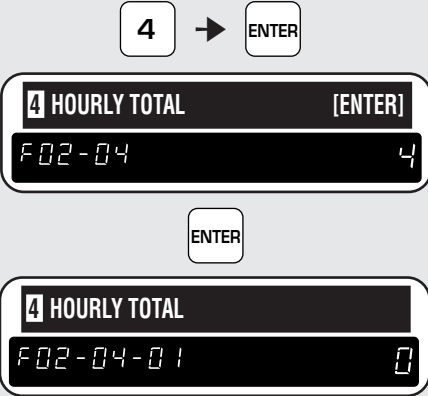

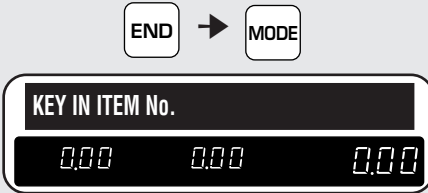
The displays shown below have both a character and a segment display. However, the AC-3000E has only a segment display.

Step	Description	Keys and Display
1	Total Mode <ul style="list-style-type: none"> Enter the password followed by the MODE key to access the Total Mode. <p style="text-align: center;">Example: Password = 8 0 0 0</p>	
2	Total Report Menu <ul style="list-style-type: none"> Press the DOWN ARROW key twice to access the Total Report menu. <ul style="list-style-type: none"> Press the ENTER key. 	
3	Hourly Total Menu <ul style="list-style-type: none"> Enter "4" followed by the ENTER key to select the Hourly Total menu. <ul style="list-style-type: none"> Press the ENTER key to access the printing mode. 	
4	Print <ul style="list-style-type: none"> Press the PRINT key. 	
5	Return to Initial Display <ul style="list-style-type: none"> Press the END key to return to the main menu. Press the MODE key to return to the initial display, if necessary. 	

2.8 Periodical Total Report

The Periodical Total Report allows the manager to obtain a list that shows totals for one-month period prior to a predetermined closing date.

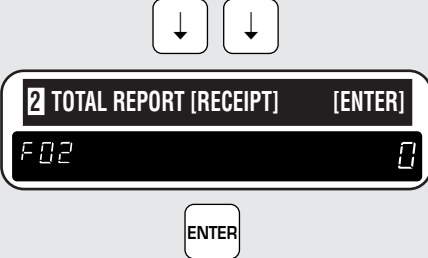
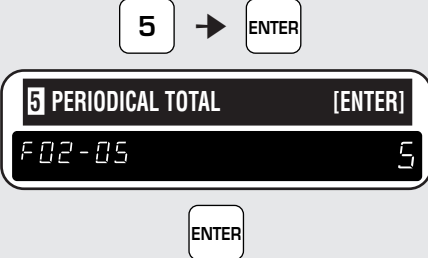
The displays shown below have both a character and a segment display. However, the AC-3000E has only a segment display.

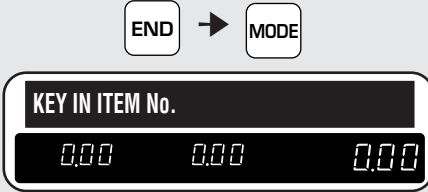
Step	Description	Keys and Display
1	Total Mode <ul style="list-style-type: none"> Enter the password followed by the MODE key to access the Total Mode. <p style="text-align: center;">Example: Password = 8 0 0 0</p>	
2	Total Report Menu <ul style="list-style-type: none"> Press the DOWN ARROW key twice to access the Total Report menu. Press the ENTER key. 	
3	Periodical Total Menu <ul style="list-style-type: none"> Enter "5" followed by the ENTER key to select the Periodical Total menu. Press the ENTER key to access the printing mode. 	 
4	Print <ul style="list-style-type: none"> Press the PRINT key. 	
5	Return to Initial Display <ul style="list-style-type: none"> Press the END key to return to the main menu. Press the MODE key to return to the initial display, if necessary. 	

2.9 Operator Total Report

The Operator Total Report only functions when the AC-3000/3000E is programmed to use the operator system. Daily totals are listed with the information of operator numbers and names.

The displays shown below have both a character and a segment display. However, the AC-3000E has only a segment display.

Step	Description	Keys and Display
1	Total Mode <ul style="list-style-type: none"> Enter the password followed by the MODE key to access the Total Mode. <p style="text-align: center;">Example: Password = 8 0 0 0</p>	
2	Total Report Menu <ul style="list-style-type: none"> Press the DOWN ARROW key twice to access the Total Report menu. <ul style="list-style-type: none"> Press the ENTER key. 	
3	Operator Total Menu <ul style="list-style-type: none"> Enter "6" followed by the ENTER key to select the Operator Total menu. <ul style="list-style-type: none"> Press the ENTER key to access the printing mode. 	
4	Print <ul style="list-style-type: none"> Press the PRINT key. 	
5	Return to Initial Display <ul style="list-style-type: none"> Press the END key to return to the main menu. Press the MODE key to return to the initial display, if necessary. 	

2.10 Zone Total Report

The Zone Total Report is only available in receipt application. The report consists of two total reports, Customer Unit Price Total Report and Customer Pieces Total Report, and will be produced in pre-programmed zones.





The displays shown below have both a character and a segment display. However, the AC-3000E has only a segment display.

Step	Description	Keys and Display
1	<p>Total Mode</p> <ul style="list-style-type: none"> Enter the password followed by the MODE key to access the Total Mode. <p>Example: Password = 8 0 0 0</p>	<p>8 0 0 0 → MODE</p> <p>*TOTAL MODE PRESS [↓] KEY</p> <p>F00</p>
2	<p>Total Report Menu</p> <ul style="list-style-type: none"> Press the DOWN ARROW key twice to access the Total Report menu. Press the ENTER key. 	<p>↓ ↓</p> <p>2 TOTAL REPORT [RECEIPT] [ENTER]</p> <p>F02</p> <p>ENTER</p>
3	<p>Zone Total Menu</p> <ul style="list-style-type: none"> Enter "7" followed by the ENTER key to select the Zone Total menu. 	<p>7 → ENTER</p> <p>7 ZONE TOTAL [ENTER]</p> <p>F02-07</p>
4	<p>Select Total Report.</p> <ul style="list-style-type: none"> Press the ENTER key to select Customer Unit Price Total mode. <p>OR</p> <ul style="list-style-type: none"> Press the ENTER key to select Customer Pieces Total mode. 	<p>↓</p> <p>7 CUSTOMER UNIT PRICE TOTAL</p> <p>F02-07-01</p> <p>↓ ↑</p> <p>↓</p> <p>7 CUSTOMER PIECES TOTAL</p> <p>F02-07-02</p>
5	<p>Print</p> <ul style="list-style-type: none"> Press the PRINT key. 	<p>PRINT</p>
6	<p>Return to Initial Display</p> <ul style="list-style-type: none"> Press the END key to return to the main menu. Press the MODE key to return to the initial display, if necessary. 	<p>END → MODE</p> <p>KEY IN ITEM No.</p> <p>0.00 0.00 0.00</p>

2.11 Week Total Report

The Week Total Report allows the manager to obtain a list of totals for specific time periods during each day of the week.

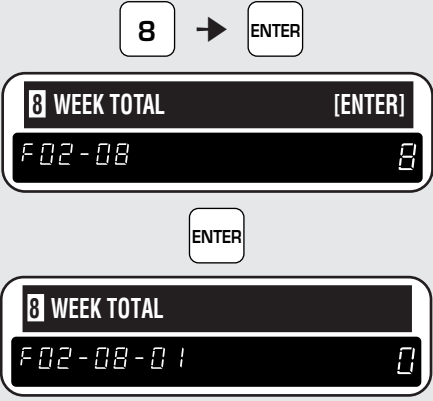

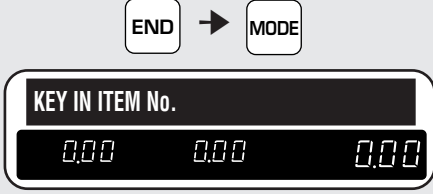
The displays shown below have both a character and a segment display. However, the AC-3000E has only a segment display.

Step	Description	Keys and Display
1	Total Mode <ul style="list-style-type: none"> Enter the password followed by the MODE key to access the Total Mode. <p style="text-align: center;">Example: Password = 8 0 0 0</p>	
2	Total Report Menu <ul style="list-style-type: none"> Press the DOWN ARROW key twice to access the Total Report menu. 	
3	Week Total Menu <ul style="list-style-type: none"> Enter "8" followed by the ENTER key to select the Week Total menu. Press the ENTER key to access the printing mode. 	
4	Print <ul style="list-style-type: none"> Press the PRINT key. 	
5	Return to Initial Display <ul style="list-style-type: none"> Press the END key to return to the main menu. Press the MODE key to return to the initial display, if necessary. 	

2.12 Total Clear

After printing the necessary reports, all of the accumulated totals have to be cleared so that the accumulation can begin from zero again.

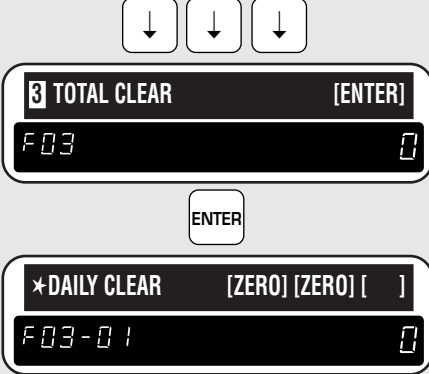

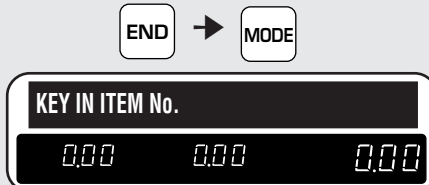
The displays shown below have both a character and a segment display. However, the AC-3000E has only a segment display.

Step	Description	Keys and Display
1	<p>Total Mode</p> <ul style="list-style-type: none"> Enter the password followed by the MODE key to access the Total Mode. <p>Example: Password = 8 0 0 0</p>	
2	<p>Total Clear Menu</p> <ul style="list-style-type: none"> Press the DOWN ARROW key three times to access the Total Clear menu. Press the ENTER key to enter the Total Clear mode. 	
3	<p>Report Categories</p> <ul style="list-style-type: none"> Use the DOWN ARROW or UP ARROW key to select the desired report. <ul style="list-style-type: none"> ▪F03-01 = Daily Total Clear <i>Note: This operation also clears the Hourly and Operator Reports.</i> ▪F03-02 = Weekly Total Clear <i>Note: This operation also clears the Daily Total Reports.</i> ▪F03-03 = Monthly Total Clear <i>Note: This operation also clears the Daily, Weekly, and Periodical Reports.</i> ▪F03-04 = Hourly Total Clear ▪F03-05 = All Total Clear <i>Note: This operation clears all the reports.</i> 	
4	<p>Total Clear</p> <ul style="list-style-type: none"> Press the ZERO key twice to clear the report. 	
5	<p>Return to Initial Display</p> <ul style="list-style-type: none"> Press the END key to return to the main menu. Press the MODE key to return to the initial display, if necessary. 	

2.13 Daily Total Report (Label)

This report can only be printed on the label.

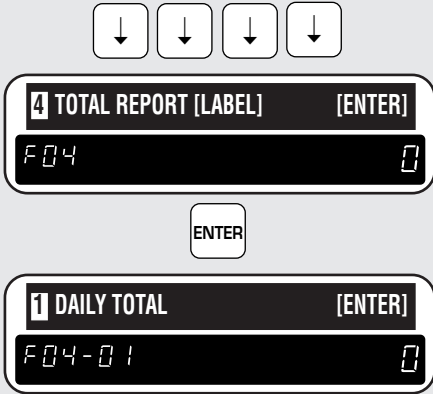
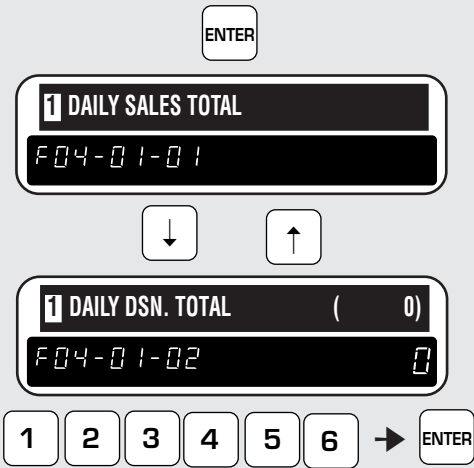
The displays shown below have both a character and a segment display. However, the AC-3000E has only a segment display.

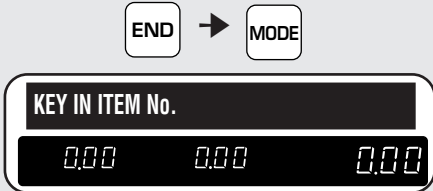
Step	Description	Keys and Display
1	<p>Total Mode</p> <ul style="list-style-type: none"> Enter the password followed by the MODE key to access the Total Mode. <p>Example: Password = 8 0 0 0</p>	
2	<p>Total Report Menu</p> <ul style="list-style-type: none"> Press the DOWN ARROW key four times. Press the ENTER key to access the Daily Total Report menu. 	
3	<p>Report Selection</p> <ul style="list-style-type: none"> Press the ENTER key, and select the desired Total Report by using the DOWN ARROW or UP ARROW key. <ul style="list-style-type: none"> F04-01-01 = Daily Sales Total F04-01-02 = Daily Designated PLU Total <p>Example: PLU no. 1 2 3 4 5 6</p>	
4	<p>Print</p> <ul style="list-style-type: none"> Press the PRINT key. 	
5	<p>Return to Initial Display</p> <ul style="list-style-type: none"> Press the END key to return to the main menu. Press the MODE key to return to the initial display, if necessary. 	

CHAPTER 3

PROGRAMMING

Contents

3.1	Creating PLUs	28
3.2	Deleting PLUs	36
3.3	Price Change File	37
3.4	Extra Message File	41
3.5	Coupon Message File	43
3.6	Date and Time	45
3.7	Store Names and Addresses	46
3.8	Preset Keys	49
3.9	Printing PLU/Message Information ..	51
3.10	Department Codes and Names ...	53
3.11	Group Codes and Names	55
3.12	Operator Codes and Names	57
3.13	Advertisement Messages	59
3.14	Campaign Files	62
3.15	Total Barcode	64
3.16	Other Programming	65
3.17	Setting On-line/Off-line	68
3.18	Master File Downloading	69
3.19	Nutrition Files	72
3.20	Changing Unit Price/Fixed Price ...	78

3.1 Creating PLUs

This section explains how to create a product (PLU) in the AC-3000/3000E.





Some steps listed below may not be available. At the time of installation the AC-3000/3000E may be configured to bypass unused steps.

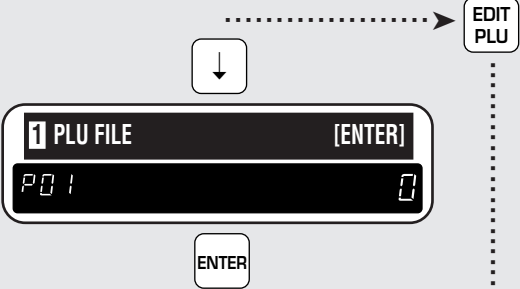
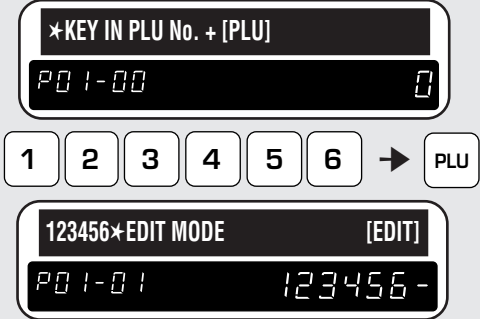
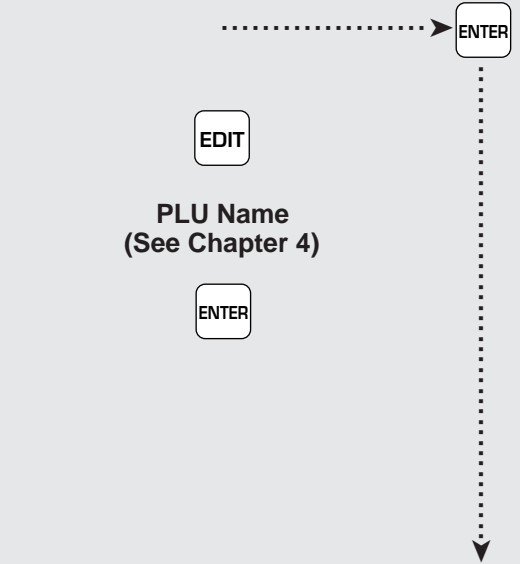



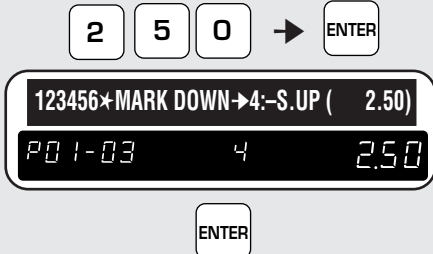
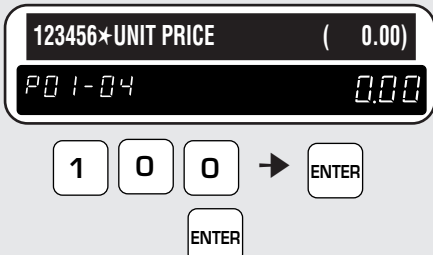

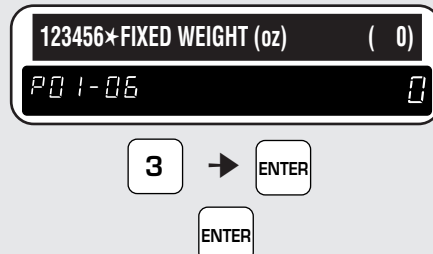

Note: Confirm that the Program Key Sheet, and not the Operation Key Sheet, is being used for this operation.

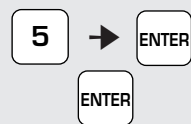

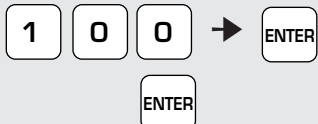
The displays shown below have both a character and a segment display. However, the AC-3000E has only a segment display.

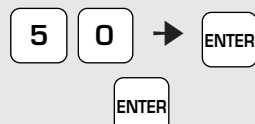
Step	Description	Keys and Display
1	<p>Program Mode</p> <ul style="list-style-type: none"> Enter the password followed by the MODE key to access the program mode. <p>Example: Password = 9 0 0 0</p> <p>Note: To exit the program mode, press the MODE key again.</p>	
2	<p>PLU Program Menu</p> <ul style="list-style-type: none"> Press the EDIT PLU key to skip this step. <p>OR</p> <ul style="list-style-type: none"> Press the DOWN ARROW key. Press the ENTER key. 	
3	<p>PLU Number (6 digits)</p> <ul style="list-style-type: none"> Enter the PLU number to be created or edited followed by the PLU key. <p>Example: PLU no. = 1 2 3 4 5 6</p>	
4	<p>PLU Name</p> <ul style="list-style-type: none"> Press the EDIT key to edit or create the PLU name. Enter the desired PLU name using the keyboard. <p>Note 1: For text editing, refer to Chapter 4. Note 2: If confirmation of the entered PLU number and name is necessary, press the PRINT key.</p> <ul style="list-style-type: none"> After finishing text entries, press the ENTER key to go to the next step. <p>OR</p> <ul style="list-style-type: none"> Press the ENTER key to skip this step. This will access the PLU type programming. 	

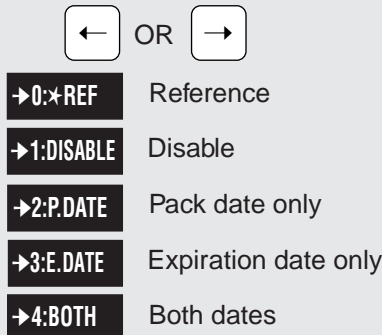
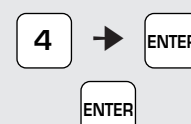

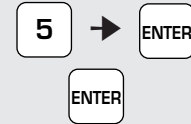
Step	Description	Keys and Display
<p>5 PLU Type</p> <ul style="list-style-type: none"> Use the LEFT ARROW or RIGHT ARROW key to view the PLU type. Select PLU type followed by the ENTER key. <p>Example: Fixed price</p> <ul style="list-style-type: none"> Press the ENTER key. 		<p>← OR →</p> <p>→0:WEIGH Weighed item →1:NON-WEIGH Non-weighed item (Fixed price)</p> <p>1 → ENTER</p> <p>123456*SALES MODE →1:NON-WEIGH (1)</p> <p>ENTER</p>
<p>6 Markdown Type</p> <ul style="list-style-type: none"> Select one of the following markdown types by using the LEFT ARROW or RIGHT ARROW key. <p>6-1 Special Price (6 digits)</p> <ul style="list-style-type: none"> When the “Special price” is selected, enter the special price followed by the ENTER key. <p>Example: Special price = \$5.00</p> <ul style="list-style-type: none"> Press the ENTER key. <p>6-2 Amount Discount (6 digits)</p> <ul style="list-style-type: none"> When the “Amount discount” is selected, enter the amount followed by the ENTER key. <p>Example: Discount amount = \$1.00</p> <ul style="list-style-type: none"> Press the ENTER key. 		<p>← OR →</p> <p>→0:NET Ordinary price →1:SPCL Special price →2:-\$ Amount discount →3:-% Percentage discount →4:S.UP Special unit price</p> <p>5 0 0 → ENTER</p> <p>123456*MARK DOWN →1:SPCL (5.00)</p> <p>ENTER</p> <p>1 0 0 → ENTER</p> <p>123456*MARK DOWN →2:-\$ (1.00)</p> <p>ENTER</p>

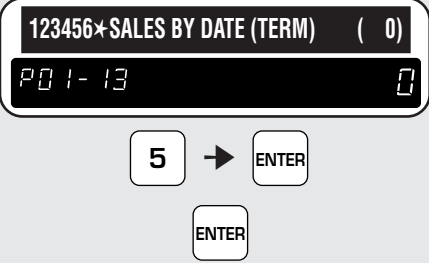
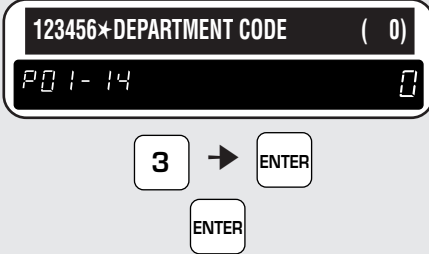
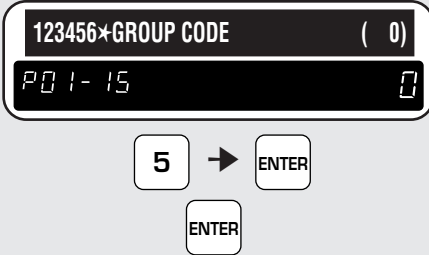
Step	Description	Keys and Display
6-3	<p>Percentage Discount (2 digits)</p> <ul style="list-style-type: none"> When the “Percentage discount” is selected, enter the percentage followed by the ENTER key. <p>Example: Discount percentage = 5%</p> <ul style="list-style-type: none"> Press the ENTER key. 	
6-4	<p>Special Unit Price (6 digits)</p> <ul style="list-style-type: none"> When the “Special unit price” is selected, enter the unit price followed by the ENTER key. <p>Example: Special unit price = \$2.50</p> <ul style="list-style-type: none"> Press the ENTER key. 	
7	<p>Unit Price (6 digits)</p> <ul style="list-style-type: none"> Enter the unit price followed by the ENTER key. <p>Example: Unit price = \$1.00</p> <ul style="list-style-type: none"> Press the ENTER key. <p>Note: For non-weighed items, skip this step.</p>	
8	<p>Fixed Price (7 digits)</p> <ul style="list-style-type: none"> Enter the fixed price followed by the ENTER key. <p>Example: Fixed price = \$8.00</p> <ul style="list-style-type: none"> Press the ENTER key. <p>Note: For weighed items, skip this step.</p>	
9	<p>Fixed Weight (0 ~ 999 oz.)</p> <ul style="list-style-type: none"> Enter the fixed weight followed by the ENTER key. <p>Example: Fixed weight = 3 oz.</p> <ul style="list-style-type: none"> Press the ENTER key. <p>Note: For weighed items, skip this step.</p>	
10	<p>Registered Code (3 digits)</p> <ul style="list-style-type: none"> Enter the registered code followed by the ENTER key. <p>Example: Registered code = 2</p> <ul style="list-style-type: none"> Press the ENTER key. <p>Note: If this programming step is not necessary, proceed to the next step.</p>	

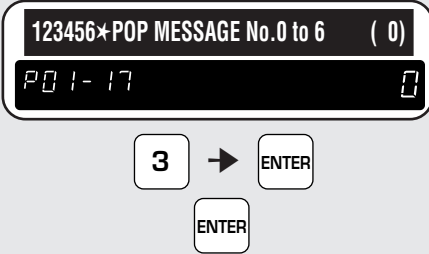
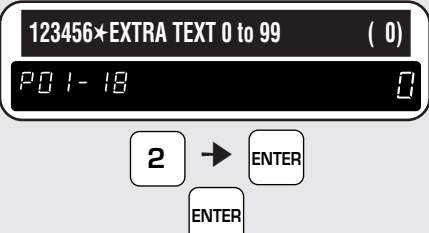
Step	Description	Keys and Display
11	Pack Quantity (3 digits) <ul style="list-style-type: none"> Enter the pack quantity followed by the ENTER key. Example: Pack quantity = 5 pcs. Press the ENTER key. Note: For weighed items skip this step. 	 
12	Cost Price (6 digits) <ul style="list-style-type: none"> Enter the cost price followed by the ENTER key. Example: Cost price = \$1.00 Press the ENTER key. Note: If this programming step is not necessary, proceed to the next step. 	 
13	Tare Weight (0.01 ~ 9.99 lb.) <ul style="list-style-type: none"> Enter the tare weight followed by the ENTER key. Example: Tare weight = 0.50 lb. Press the ENTER key. Note: Do not enter a value for non-weighed items. 	 
14	Date Print <ul style="list-style-type: none"> Use the LEFT ARROW or RIGHT ARROW key to view the available date print formats. Select the date print format followed by the ENTER key. Example: Both dates Press the ENTER key. 	  
15	Shelf Life (0 ~ 999 days) <ul style="list-style-type: none"> Enter the shelf life (number of days) followed by the ENTER key. Example: Shelf life = 5 days Press the ENTER key. 	 

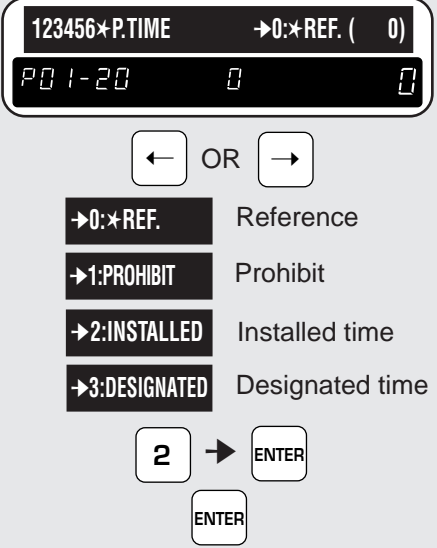
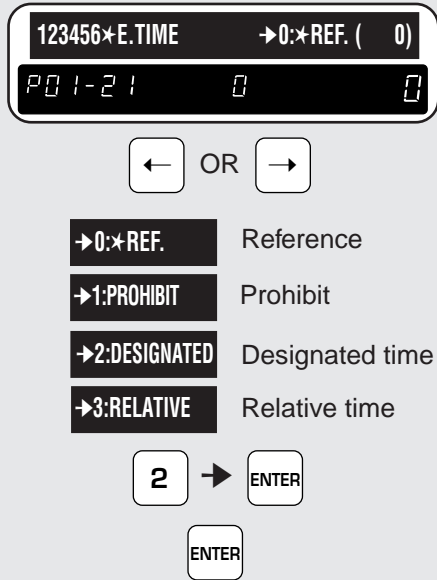
Step	Description	Keys and Display
16	<p>Sales until Set Date (0 ~ 999 days)</p> <ul style="list-style-type: none"> Enter the sales by date followed by the ENTER key. <p>Example: To be sold within the next 5 days.</p> <ul style="list-style-type: none"> Press the ENTER key. <p>Note: If this programming step is not necessary proceed to the next step.</p>	
17	<p>Department Code (3 digits)</p> <ul style="list-style-type: none"> Enter the department code followed by the ENTER key. <p>Example: Department code = 3</p> <ul style="list-style-type: none"> Press the ENTER key. 	
18	<p>Group Code (3 digits)</p> <ul style="list-style-type: none"> Enter the group code followed by the ENTER key. <p>Example: Group code = 5</p> <ul style="list-style-type: none"> Press the ENTER key. 	
19	<p>Item Code (8 digits)</p> <ul style="list-style-type: none"> Enter the item code followed by the ENTER key. <p>Example: Item code = 1 0 1 0 1 1</p> <ul style="list-style-type: none"> Press the ENTER key. 	
20	<p>POP Message (0 ~ 6)</p> <ul style="list-style-type: none"> Enter the POP message number followed by the ENTER key. <p>Note: Safe Handling Message (99)</p> <p>Example: POP message no. = 3</p> <ul style="list-style-type: none"> Press the ENTER key. 	
21	<p>Extra Text (0 ~ 99)</p> <ul style="list-style-type: none"> Enter the extra text number followed by the ENTER key. <p>Example: Extra text no. = 2</p> <ul style="list-style-type: none"> Press the ENTER key. 	

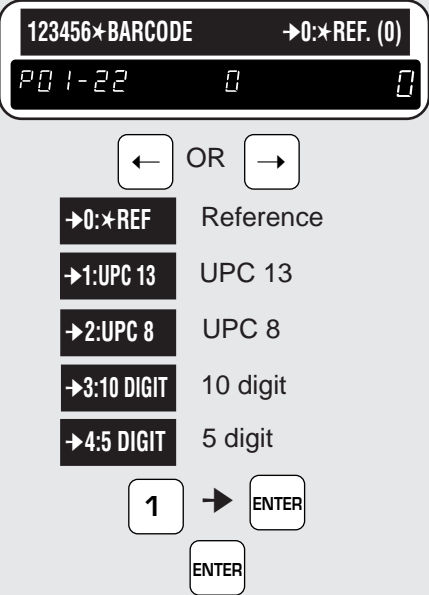
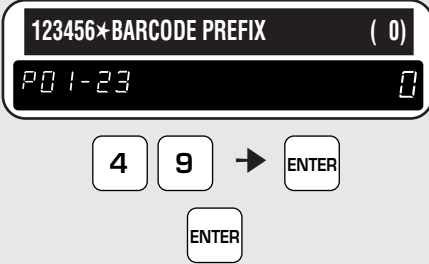
Step	Description	Keys and Display
22	<p>Coupon Text (0 ~ 99)</p> <ul style="list-style-type: none"> Enter the coupon text number followed by the ENTER key. <p>Example: Coupon text no. = 8</p> <ul style="list-style-type: none"> Press the ENTER key. 	
23	<p>Pack Time</p> <ul style="list-style-type: none"> Use the LEFT ARROW or RIGHT ARROW key to view the available pack time formats. Select the pack time followed by the ENTER key. <p>Example: Installed time</p> <ul style="list-style-type: none"> Press the ENTER key. <p>Note: If this programming step is not necessary, proceed to the next step.</p>	
24	<p>Expiration Time</p> <ul style="list-style-type: none"> Use the LEFT ARROW or RIGHT ARROW key to view the available expiration time formats. Select the expiration time followed by the ENTER key. <p>Example: Designated time</p> <ul style="list-style-type: none"> Press the ENTER key. <p>Note: If this programming step is not necessary, proceed to the next step.</p>	

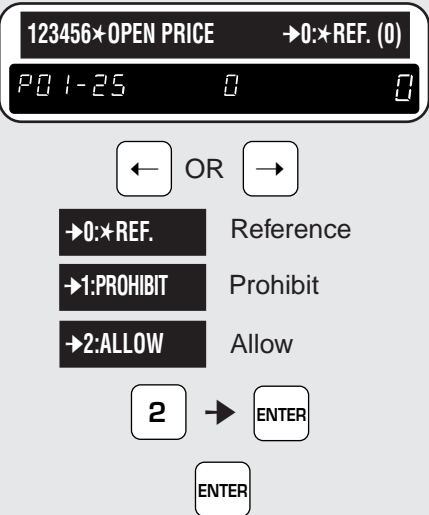
Step	Description	Keys and Display
25	<p>Barcode Type</p> <ul style="list-style-type: none"> Use the LEFT ARROW or RIGHT ARROW key to view the barcode type. Select the barcode type followed by the ENTER key. <p>Example: UPC 13</p> <ul style="list-style-type: none"> Press the ENTER key. 	 <p>123456*BARCODE →0:*REF. (0) PO 1-22 0</p> <p>← OR →</p> <p>→0:*REF Reference →1:UPC 13 UPC 13 →2:UPC 8 UPC 8 →3:10 DIGIT 10 digit →4:5 DIGIT 5 digit</p> <p>1 → ENTER ENTER</p>
26	<p>Barcode Prefix (2 digits)</p> <ul style="list-style-type: none"> Enter the barcode prefix followed by the ENTER key. <p>Example: Barcode prefix = 49</p> <ul style="list-style-type: none"> Press the ENTER key. 	 <p>123456*BARCODE PREFIX (0) PO 1-23 0</p> <p>4 9 → ENTER ENTER</p>
27	<p>UPC or 10 Digit Barcode</p> <ul style="list-style-type: none"> Enter the UPC or 10 digit barcode number followed by the ENTER key. <p>Example: 2 2 2 2 2 2 2 2 2 2</p> <ul style="list-style-type: none"> Press the ENTER key. 	 <p>123456*10 DIG. CODE (0) PO 1-24 0</p> <p>2 2 → ENTER ENTER</p>
28	<p>Open Price</p> <ul style="list-style-type: none"> Use the LEFT ARROW or RIGHT ARROW key to view whether or not the PLU is to allow price change. Select the desired condition followed by the ENTER key. <p>Example: Allow</p> <ul style="list-style-type: none"> Press the ENTER key. 	 <p>123456*OPEN PRICE →0:*REF. (0) PO 1-25 0</p> <p>← OR →</p> <p>→0:*REF. Reference →1:PROHIBIT Prohibit →2:ALLOW Allow</p> <p>2 → ENTER ENTER</p>

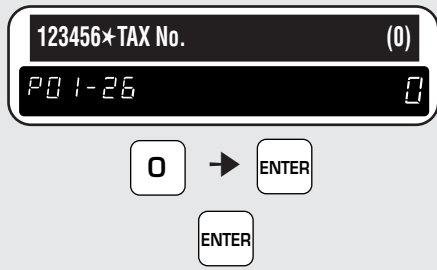
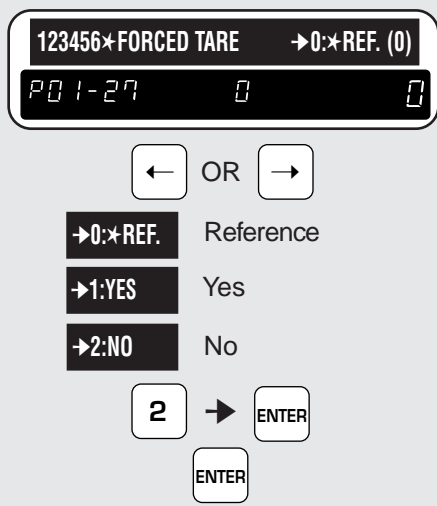
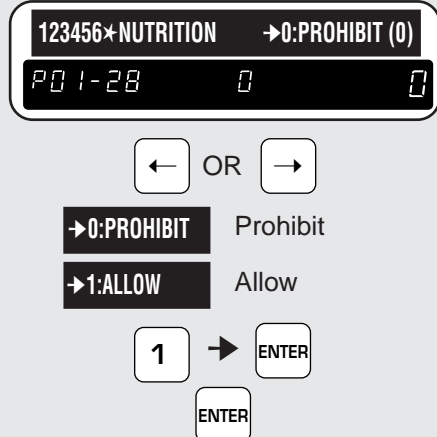
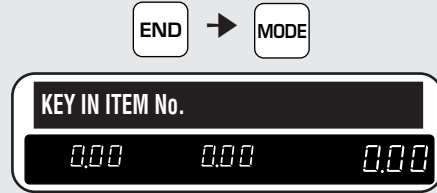

Step	Description	Keys and Display
29	<p>Tax No. (0 ~ 99)</p> <p><i>Note: This program is only available in the receipt application.</i></p> <ul style="list-style-type: none"> Enter the tax no. followed by the ENTER key. <p>Example: Tax no. = 0</p> <ul style="list-style-type: none"> Press the ENTER key. 	
30	<p>Forced Tare</p> <ul style="list-style-type: none"> Use the LEFT ARROW or RIGHT ARROW key to view whether a tare weight must be entered before completing a transaction. Select the desired condition followed by the ENTER key. <p>Example: No</p> <ul style="list-style-type: none"> Press the ENTER key. 	
31	<p>Nutrition Panel</p> <ul style="list-style-type: none"> Use the LEFT ARROW or RIGHT ARROW key to view whether or not the nutrition panel is to be printed. Select the desired condition followed by the ENTER key. <p>Example: Allow</p> <ul style="list-style-type: none"> Press the ENTER key. 	
32	<p>Repeat</p> <ul style="list-style-type: none"> Repeat steps 3 through 30 for any other PLU programming. 	
33	<p>Return to Initial Display</p> <ul style="list-style-type: none"> When all PLUs have been programmed, press the END key. Press the MODE key to return to the initial display. 	

3.2 Deleting PLUs

The following procedure is used to delete products (PLUs) from memory.

Note: Confirm that the Program Key Sheet, and not the Operation Key Sheet, is being used for this operation.

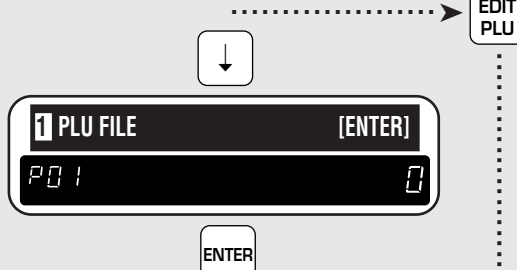
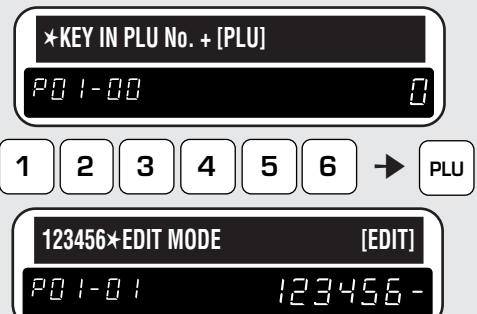
The displays shown below have both a character and a segment display. However, the AC-3000E has only a segment display.

Step	Description	Keys and Display
1	Program Mode <ul style="list-style-type: none"> Enter the password followed by the MODE key to access the program mode. <p>Example: Password = 9 0 0 0</p> <p>Note: To exit the program mode, press the MODE key again.</p>	
2	PLU Program Menu <ul style="list-style-type: none"> Press the EDIT PLU key to skip this step. <p>OR</p> <ul style="list-style-type: none"> Press the DOWN ARROW key. Press the ENTER key. 	
3	PLU Number (6 digits) <ul style="list-style-type: none"> Enter the PLU number, followed by the PLU key. <p>Example: PLU no. = 1 2 3 4 5 6</p>	
4	Delete Mode <ul style="list-style-type: none"> Press the CHARACTER DELETE key to enter the delete mode. Press the CHARACTER DELETE key again to delete the complete PLU record. <p>Note: Press the ENTER key to cancel the deletion.</p>	
5	Repeat <ul style="list-style-type: none"> Repeat steps 3 and 4 for desired PLUs to be deleted. 	
6	Return to Initial Display <ul style="list-style-type: none"> When all PLUs have been deleted, press the END key. Press the MODE key to return to the initial display. 	

3.3 Price Change File (AC-3000 only)

This file can be programmed in the master terminal as well as in a stand-alone terminal.

Note: Confirm that the Program Key Sheet, and not the Operation Key Sheet, is being used for this operation.

The displays shown below have both a character and a segment display. However, the AC-3000E has only a segment display.

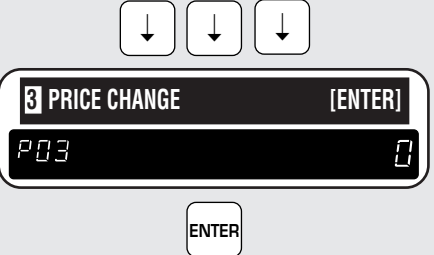
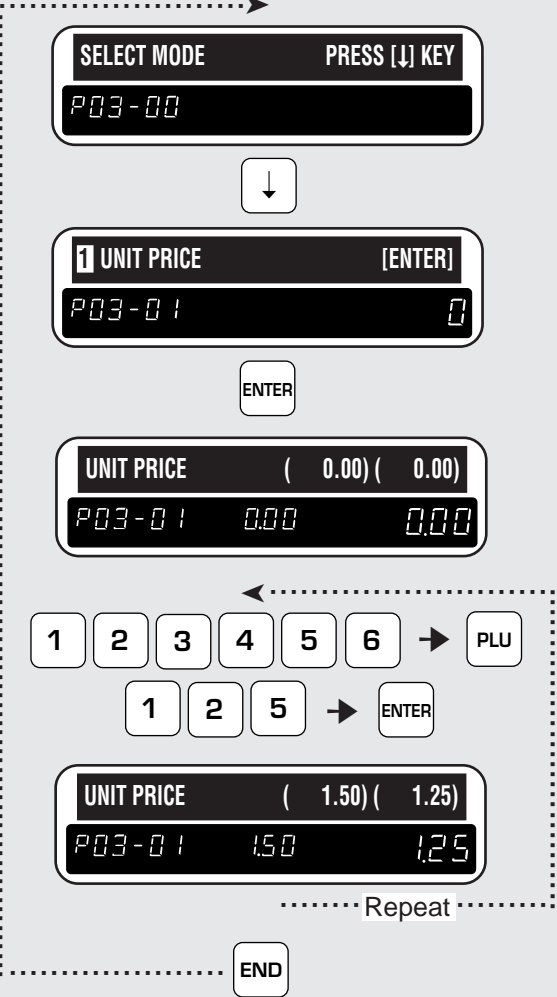
Step	Description	Keys and Display
1	Program Mode <ul style="list-style-type: none"> Enter the password followed by the MODE key to access the program mode. Example: Password = 9 0 0 0 Note: To exit the program mode, press the MODE key again. 	
2	Price Change Mode <ul style="list-style-type: none"> Press the DOWN ARROW key three times. Press the ENTER key. 	
3	Unit Price Change <ul style="list-style-type: none"> Select the unit price change menu using the DOWN ARROW key. Press the ENTER key. Enter the PLU number followed by the PLU key. Example: PLU no. = 1 2 3 4 5 6 Enter the PLU unit price followed by the ENTER key. Example: Current unit price = \$1.50 New unit price = \$1.25 Change the unit price for any other PLUs. After changing all unit prices, press the END key. 	

Step	Description	Keys and Display
4	<p>Fixed Price Change</p> <ul style="list-style-type: none"> Select the fixed price change menu using the DOWN ARROW key. Press the ENTER key. Enter the PLU number followed by the PLU key. Example: PLU no. = 1 2 3 4 5 6 Enter the PLU fixed price followed by the ENTER key. Example: Current fixed price = \$2.80 New fixed price = \$2.50 Change the fixed price for any other PLUs. After changing all fixed prices, press the END key. 	
5	<p>Mark Down Change</p> <p>The screen for the type of mark down (percentage discount, amount discount, special price, or special unit price) corresponding to the PLU will be automatically displayed.</p> <ul style="list-style-type: none"> Select the discount change menu using the DOWN ARROW key. Press the ENTER key. Enter the PLU number followed by the PLU key. Example: PLU no. = 1 2 3 4 5 6 Enter the value followed by the ENTER key. Example: Current discount rate = 0% New discount rate = 10% Change the discount for any other PLUs. After changing all discounts, press the END key. 	

Step	Description	Keys and Display
6	<p>Batch File for Unit Price</p> <p>This procedure is used to register PLU unit price changes for up to 200 PLUs. These price changes stored in the batch file are saved in the PLU master file upon performing "Saving Batch File to Master File". U/P or F/P is automatically selected based on PLU type.</p> <ul style="list-style-type: none"> Select the batch menu using the DOWN ARROW key. Press the ENTER key. Enter the PLU number followed by the PLU key. Example: PLU no. = 1 2 3 4 5 6 Enter the PLU price followed by the ENTER key. Example: Current unit price = \$1.50 New unit price = \$1.25 Change the price for any other PLUs. After changing all prices, press the END key. 	
7	<p>Saving Batch File to Master File</p> <p>This procedure is used to save PLU unit price changes from the batch file to the PLU master file.</p> <ul style="list-style-type: none"> Press the ENTER key. Press the ENTER key to save PLU unit price changes from the batch file to the PLU master file. <p>Note: Press the CHARACTER DELETE key if saving the price changes is not necessary.</p>	

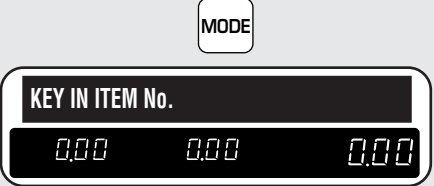
Step	Description	Keys and Display
8	<p>Return to Initial Display</p> <ul style="list-style-type: none">• Press the MODE key to return to the initial display.	 <p>The diagram shows a control panel with a square button labeled 'MODE' at the top. Below it is a rectangular display screen. The screen is divided into two sections: the top section contains the text 'KEY IN ITEM No.' and the bottom section contains three digital displays, each showing '0.00'.</p>

3.4 Extra Message File

The following procedure is used to program or delete a message file to be linked to each PLU if so programmed.

Note: Confirm that the Program Key Sheet, and not the Operation Key Sheet, is being used for this operation.

The displays shown below have both a character and a segment display. However, the AC-3000E has only a segment display.

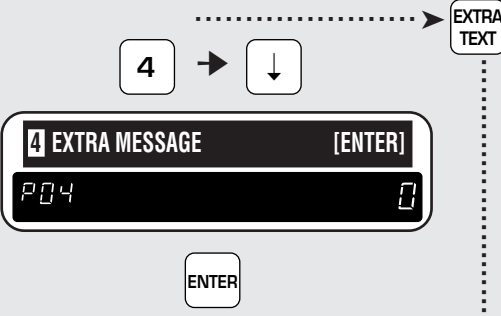
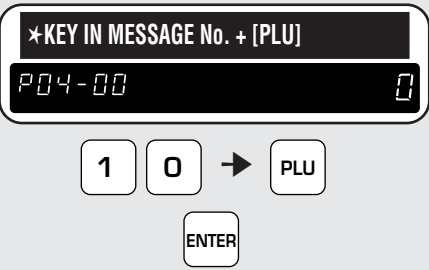
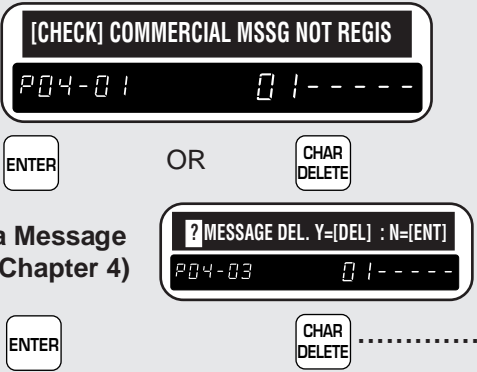
Step	Description	Keys and Display
1	<p>Program Mode</p> <ul style="list-style-type: none"> Enter the password followed by the MODE key to access the program mode. <p>Example: Password = 9 0 0 0</p> <p>Note: To exit the program mode, press the MODE key again.</p>	
2	<p>Extra Message Program Mode</p> <ul style="list-style-type: none"> Press the EXTRA TEXT key to skip this step. OR Enter "4" followed by the DOWN ARROW key. Press the ENTER key. 	
3	<p>Message Number (1 ~ 99)</p> <ul style="list-style-type: none"> Enter the message number followed by the PLU key. <p>Example: Message no. = 1 0</p> <ul style="list-style-type: none"> Press the ENTER key. 	
4	<p>Text Edit/Delete</p> <ul style="list-style-type: none"> Text Edit <ul style="list-style-type: none"> Press the ENTER key to enter the text edit mode. Enter the message using the keyboard. Note: For text editing refer to Chapter 4. When complete, press the ENTER key. Text Delete <ul style="list-style-type: none"> Press the CHARACTER DELETE key to enter the delete mode. Press the CHARACTER DELETE key again to delete the text. Note: Press the ENTER key to cancel the deletion. 	

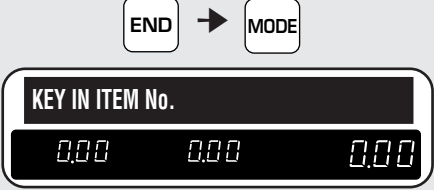
Step	Description	Keys and Display
5	Repeat <ul style="list-style-type: none"> Repeat steps 3 and 4 for any other messages to be created/edited. 	
6	Return to Initial Display <ul style="list-style-type: none"> When all desired messages have been programmed, press the END key. Press the MODE key to return to the initial display. 	 <p>The diagram illustrates the key sequence and the resulting display. At the top, a button labeled 'END' has an arrow pointing to a button labeled 'MODE'. Below this, a digital display is shown with the text 'KEY IN ITEM No.' on the top line and three '0.00' values on the bottom line, indicating the initial display state.</p>

3.5 Coupon Message File

The following procedure is used to program or delete a coupon message file to be linked to each PLU if so programmed.

Note: Confirm that the Program Key Sheet, and not the Operation Key Sheet, is being used for this operation.

The displays shown below have both a character and a segment display. However, the AC-3000E has only a segment display.

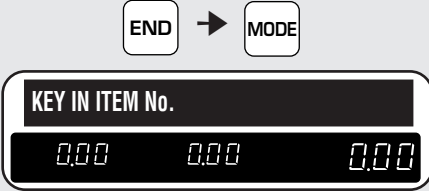

Step	Description	Keys and Display
1	<p>Program Mode</p> <ul style="list-style-type: none"> Enter the password followed by the MODE key to access the program mode. <p>Example: Password = 9 0 0 0</p> <p>Note: To exit the program mode, press the MODE key again.</p>	
2	<p>Coupon Message Program Mode</p> <ul style="list-style-type: none"> Press the COUPON TEXT key to skip this step. <p>OR</p> <ul style="list-style-type: none"> Enter "5" followed by the DOWN ARROW key. Press the ENTER key. 	
3	<p>Message Number (1 ~ 99)</p> <ul style="list-style-type: none"> Enter the message number followed by the PLU key. <p>Example: Message no. = 5</p> <ul style="list-style-type: none"> Press the ENTER key. 	
4	<p>Text Edit/Delete</p> <ul style="list-style-type: none"> Text Edit <ul style="list-style-type: none"> Press the ENTER key to enter the text edit mode. Enter the message using the keyboard. Note: For text editing refer to Chapter 4. When complete, press the ENTER key. Text Delete <ul style="list-style-type: none"> Press the CHARACTER DELETE key to enter the delete mode. Press the CHARACTER DELETE key again to delete the text. Note: Press the ENTER key to cancel the deletion. 	

Step	Description	Keys and Display
5	Repeat <ul style="list-style-type: none"> Repeat steps 3 and 4 for any other messages to be created/edited. 	
6	Return to Initial Display <ul style="list-style-type: none"> When all desired messages have been programmed, press the END key. Press the MODE key to return to the initial display. 	 <p>The diagram illustrates the key sequence and the resulting display. At the top, a button labeled 'END' is followed by a right-pointing arrow and a button labeled 'MODE'. Below this sequence is a rectangular digital display. The top line of the display shows the text 'KEY IN ITEM No.' followed by a dark rectangular area. The bottom line of the display shows three '000' values, each preceded by a small space, indicating a three-digit display for each of the three items.</p>

3.6 Date and Time

Note: Confirm that the Program Key Sheet, and not the Operation Key Sheet, is being used for this operation.

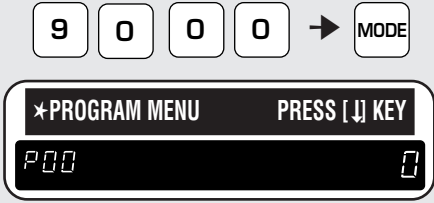
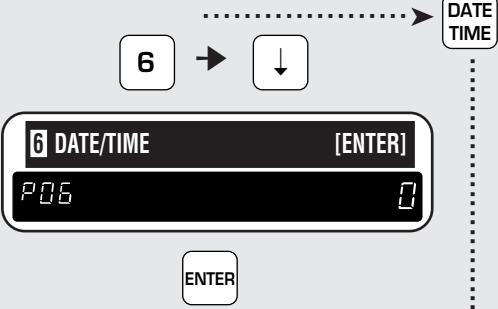
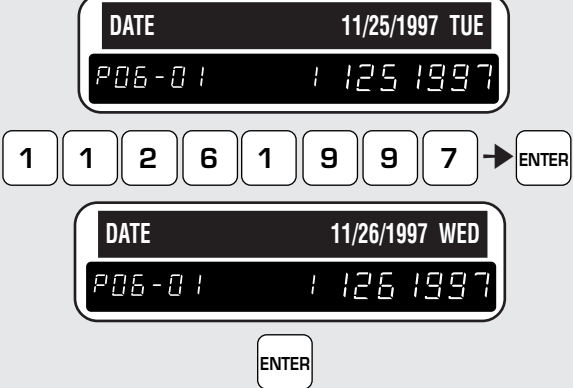
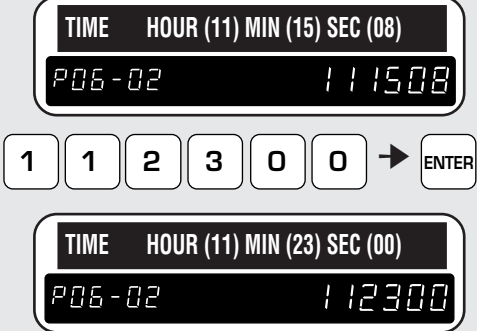
The displays shown below have both a character and a segment display. However, the AC-3000E has only a segment display.



Step	Description	Keys and Display
1	Program Mode <ul style="list-style-type: none"> Enter the password followed by the MODE key to access the program mode. Example: Password = 9 0 0 0 Note: To exit the program mode, press the MODE key again. 	
2	Date/Time Program Mode <ul style="list-style-type: none"> Press the DATE TIME key to skip this step. OR Enter "6" followed by the DOWN ARROW key. Press the ENTER key. 	
3	New Date <ul style="list-style-type: none"> Enter the new date (MMDDYYYY) followed by the ENTER key. Example: Current date = November 25, 1997 New date = November 26, 1997 Press the ENTER key. 	
4	New Time <ul style="list-style-type: none"> Enter the time (hhmmss) using 24-hour clock, followed by the ENTER key. Example: Current time = 11:15:08 New time = 11:23:00 	
5	Return to Initial Display <ul style="list-style-type: none"> After the new date and time have been entered, press the END key. Press the MODE key to return to the initial display. 	

3.7 Store Names and Addresses

The AC-3000/3000E can be programmed with store names and addresses, which allow the operator to select store information to be printed on labels. The following procedure shows how to program store name and address information.

Note: Confirm that the Program Key Sheet, and not the Operation Key Sheet, is being used for this operation.

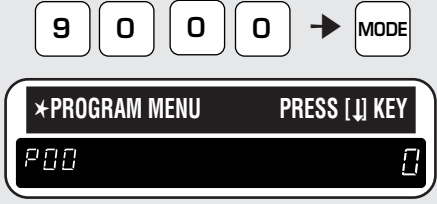
The displays shown below have both a character and a segment display. However, the AC-3000E has only a segment display.

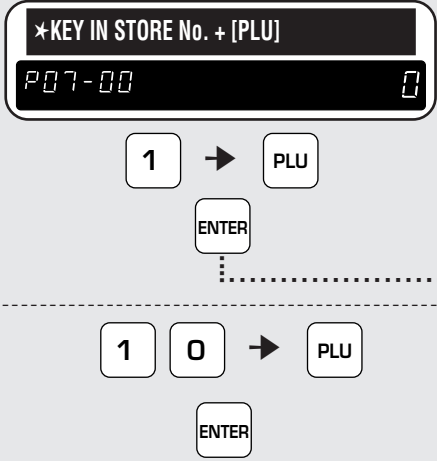
Step	Description	Keys and Display
1	Program Mode <ul style="list-style-type: none"> Enter the password followed by the MODE key to access the program mode. Example: Password = 9 0 0 0 Note: To exit the program mode, press the MODE key again. 	
2	Program Mode <ul style="list-style-type: none"> Press the STORE NAME key to skip this step. <p>OR</p> <ul style="list-style-type: none"> Enter "7" followed by the DOWN ARROW key. Press the ENTER key. 	
3	Store Number <ul style="list-style-type: none"> Store Number (1 ~ 9) <ul style="list-style-type: none"> Enter the store number followed by the PLU key. Example: Store no. = 1 Press the ENTER key. Go to step 4. Store and Telephone Numbers (10) <ul style="list-style-type: none"> Note: This program is only available in the receipt application. Enter "10" followed by the PLU key. Press the ENTER key. Go to step 6. 	

Step 4
Step 6

Step	Description	Keys and Display
4	<p>Select Store Name or Address</p> <ul style="list-style-type: none"> Use the DOWN ARROW key to select the store name or address. <p>▪ Store Name</p> <ul style="list-style-type: none"> Select the store name menu using the DOWN ARROW key. Enter the store name using the keyboard. <p>Note: For text editing, refer to Chapter 4.</p> <ul style="list-style-type: none"> Press the ENTER key. <p>▪ Store Address (max. 47 characters)</p> <ul style="list-style-type: none"> Select the store address menu using the DOWN ARROW key. Enter the store address using the keyboard. <p>Note: For text editing, refer to Chapter 4.</p> <ul style="list-style-type: none"> Press the ENTER key. <p>▪ Delete</p> <ul style="list-style-type: none"> Select the delete mode using the DOWN ARROW key. Press the CHARACTER DELETE key to delete the store data. <p>Note: Press the ENTER key to cancel the deletion.</p>	<p>The diagram illustrates the sequence of operations for selecting and editing store data. It is divided into three main sections by dashed lines:</p> <ul style="list-style-type: none"> Section 1: Shows the initial screen '1 STORE NAME [ENTER]' with the display 'P07-01 01-----'. Below it, an 'ENTER' key and a 'DOWN ARROW' key are shown. A dashed arrow points from the 'DOWN ARROW' key to the next screen. Section 2: Shows the screen '2 STORE ADDRESS [ENTER]' with the display 'P07-02 01-----'. Below it, an 'ENTER' key and a 'DOWN ARROW' key are shown. A dashed arrow points from the 'DOWN ARROW' key to the next screen. Section 3: Shows the screen '3 ERASE STORE [ENTER]' with the display 'P07-03 01-----'. Below it, an 'ENTER' key is shown. A dashed arrow points from the 'ENTER' key to the final screen. <p>The final screen shows '2 STORE DEL. Y:[DEL] : N:[ENT]' with the display 'P07-03-01 01-----'. Below it, a 'CHAR DELETE' key is shown.</p>
5	<p>Repeat</p> <ul style="list-style-type: none"> Repeat steps 3 and 4 for any other store data. 	

Step	Description	Keys and Display
6	<p>Select Account No. or Telephone No.</p> <ul style="list-style-type: none"> Use the DOWN ARROW key to select the store name or address. <p>▪ Account Number</p> <ul style="list-style-type: none"> Select the account number menu using the DOWN ARROW key. Enter the account number using the keyboard. <p><i>Note: For text editing, refer to Chapter 4.</i></p> <ul style="list-style-type: none"> Press the ENTER key. <p>▪ Telephone Number</p> <ul style="list-style-type: none"> Select the telephone number menu using the DOWN ARROW key. Enter the telephone number using the keyboard. <p><i>Note: For text editing, refer to Chapter 4.</i></p> <ul style="list-style-type: none"> Press the ENTER key. <p>▪ Delete</p> <ul style="list-style-type: none"> Select the delete mode using the DOWN ARROW key. Press the CHARACTER DELETE key to delete the account and telephone number data. <p><i>Note: Press the ENTER key to cancel the deletion.</i></p>	<p>The diagram illustrates the sequence of key presses and displays for Step 6. It starts with the display '1 ACCOUNT No.' and 'P07-01 01-----'. Pressing the ENTER key leads to the 'Store Name (See Chapter 4)' screen. Pressing the ENTER key leads to the display '2 TELEPHONE No.' and 'P07-02 01-----'. Pressing the ENTER key leads to the 'Store Address (See Chapter 4)' screen. Pressing the ENTER key leads to the display '3 DEL. ACCOUNT AND TEL. No.' and 'P07-03 01-----'. Pressing the ENTER key leads to the display '? No. DEL. Y:[DEL] : N:[ENT]' and 'P07-03-01 01-----'. Pressing the CHAR DELETE key leads to the next step.</p>
7	<p>Return to Initial Display</p> <ul style="list-style-type: none"> When all store names and addresses have been programmed, press the END key. Press the MODE key to return to the initial display. 	<p>The diagram shows the transition from Step 6 to Step 7. Pressing the END key leads to the MODE key, which then leads to the initial display 'KEY IN ITEM No.' and '0.00 0.00 0.00'.</p>









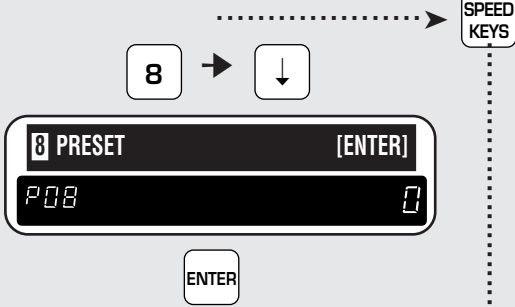
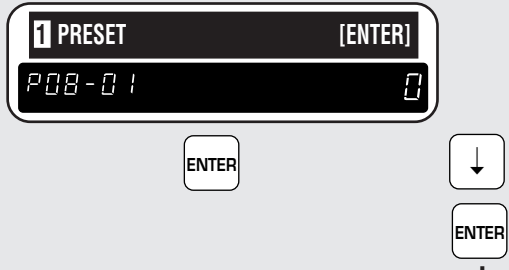
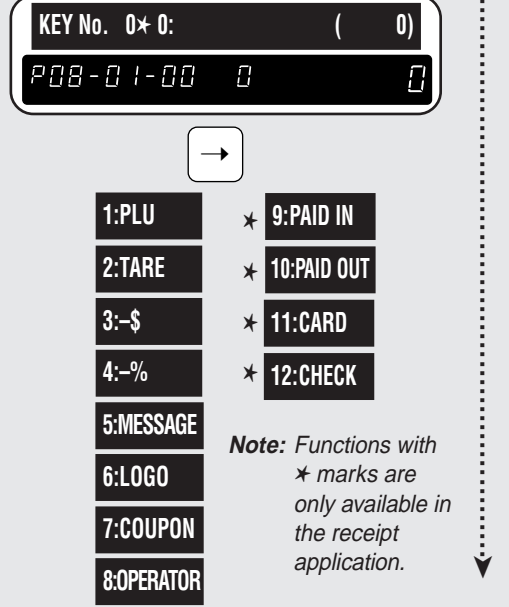



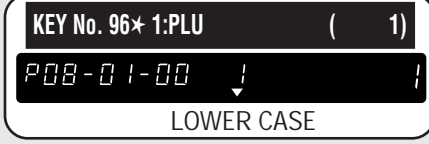
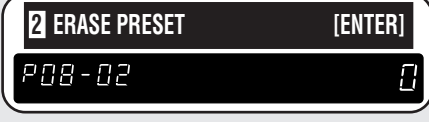

3.8 Preset Keys

The AC-3000/3000E has 88 one-touch preset keys. Each preset key can be assigned two items using the convenient SHIFT key, for a total of 176 presets. The following steps indicate how to program preset keys.

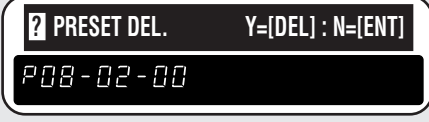
Note: Confirm that the Program Key Sheet, and not the Operation Key Sheet, is being used for this operation.

The displays shown below have both a character and a segment display. However, the AC-3000E has only a segment display.

Step	Description	Keys and Display
1	<p>Program Mode</p> <ul style="list-style-type: none"> Enter the password followed by the MODE key to access the program mode. <p>Example: Password = 9 0 0 0</p> <p>Note: To exit the program mode, press the MODE key again.</p>	
2	<p>Preset Key Mode</p> <ul style="list-style-type: none"> Press the SPEED KEYS key to skip this step. <p>OR</p> <ul style="list-style-type: none"> Enter "8" followed by the DOWN ARROW key. Press the ENTER key. 	
3	<p>Menu Selection</p> <ul style="list-style-type: none"> Press the ENTER key to select the preset key designation. <p>OR</p> <ul style="list-style-type: none"> Press the DOWN ARROW key followed by the ENTER key to select the delete menu. Then proceed to step 7. 	
4	<p>Type of Preset Keys</p> <ul style="list-style-type: none"> Select the type of preset key using the RIGHT ARROW key. 	

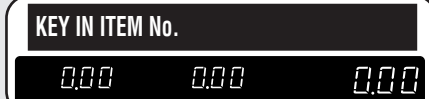
Step	Description	Keys and Display
5	<p>Key Designation</p> <ul style="list-style-type: none"> Enter the numeric value, then press any desired preset key. <p>Example: Key location number 8 (preset key) for PLU no. 1 data.</p> <p>Note 1. To confirm the value programmed in the preset key, press the preset key and the value will be displayed on the screen.</p> <p>2. Press the DOWN ARROW key to select lower presets.</p> <ul style="list-style-type: none"> After finishing all the preset key designations, proceed to step 8. 	<p>Upper Case  → </p>  <p>Lower Case   → </p> 
6	<p>Repeat</p> <ul style="list-style-type: none"> Repeat step 5 only for the same type of preset key. <p>OR</p> <ul style="list-style-type: none"> Repeat steps 4 and 5 for any other preset keys to be programmed. 	
7	<p>Deletion</p> <ul style="list-style-type: none"> Press the ENTER key. Press the CHARACTER DELETE key to delete all preset keys. <p>Note: Press the ENTER key to cancel the deletion.</p>	 <p></p>  <p></p>
8	<p>Return to Preset Menu</p> <ul style="list-style-type: none"> When all preset keys have been programmed, press the END key. 	<p></p> 
9	<p>Return to Initial Display</p> <ul style="list-style-type: none"> Press the END key again. Press the MODE key to return to the initial display. 	<p> → </p> 

3.9 Printing PLU/Message Information

Stored information can be printed on labels or receipt paper. The following steps indicate how this is done.

Note: Confirm that the Program Key Sheet, and not the Operation Key Sheet, is being used for this operation.

The displays shown below have both a character and a segment display. However, the AC-3000E has only a segment display.

Step	Description	Keys and Display
1	Program Mode <ul style="list-style-type: none"> Enter the password followed by the MODE key to access the program mode. Example: Password = 9 0 0 0 Note: To exit the program mode, press the MODE key again. 	
2	List Mode <ul style="list-style-type: none"> Press the PLU LIST key to skip this step. OR Enter "9" followed by the DOWN ARROW key. Press the ENTER key. 	
3	Print All PLUs/Messages <ul style="list-style-type: none"> To print all of the stored data, press the PRINT key. Otherwise skip this step. •• labels for checking PLU barcodes will be issued when the label is set, or •• programmed PLU data and messages will be printed when the receipt paper is set. Note: To stop printing, press the PRINT key. To continue printing, press the PRINT key again. OR Press the ENTER key to skip this step. Proceed to step 9. 	
4	List Selection <ul style="list-style-type: none"> Press the ENTER key. Use the LEFT ARROW or RIGHT ARROW key to view the type of list. Select the type of list by entering an appropriate number. Example: Message 	

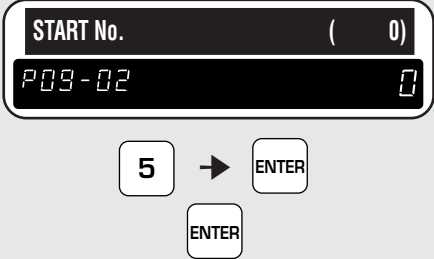
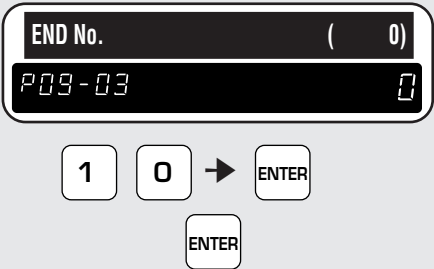
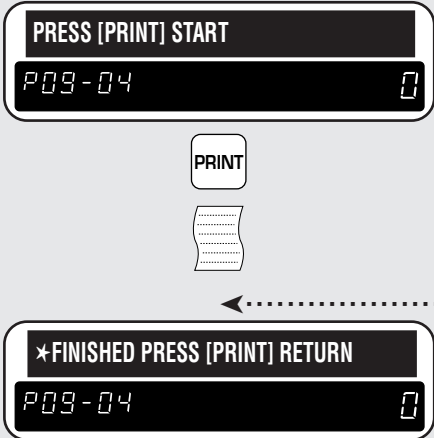
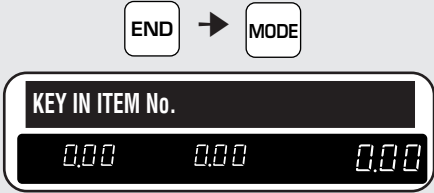
Step	Description	Keys and Display
5	<p>Start No.</p> <ul style="list-style-type: none"> Enter the start number of the range to be listed followed by the ENTER key. <p>Example: Start no. = 5</p> <ul style="list-style-type: none"> Press the ENTER key. <p>Note: This step is only used when PLUs are to be printed. Otherwise, skip this step.</p>	
6	<p>End No.</p> <ul style="list-style-type: none"> Enter the end number of the range to be listed followed by the ENTER key. <p>Example: End no. = 1 0</p> <ul style="list-style-type: none"> Press the ENTER key. <p>Note: This step is only used when PLUs are to be printed. Otherwise, skip this step.</p>	
7	<p>Print</p> <ul style="list-style-type: none"> Press the PRINT key to bring the receipt or label print out. <p>Screen during printing</p> <p>✕PRINTING PRESS [PRINT] STOP</p> <p>Note: To stop printing, press the PRINT key. To continue printing, press the PRINT key again.</p>	
8	<p>Repeat</p> <ul style="list-style-type: none"> Repeat steps 4 through 7 for any other lists. 	
9	<p>Return to Initial Display</p> <ul style="list-style-type: none"> When all PLU/Message data has been printed, press the END key. Press the MODE key to return to the initial display. 	

3.10 Department Codes and Names

Departments are used to link similar products together into a category for report purposes. The following steps show how to program a name for the reference code entered when PLUs are programmed.

Note: Confirm that the Program Key Sheet, and not the Operation Key Sheet, is being used for this operation.

The displays shown below have both a character and a segment display. However, the AC-3000E has only a segment display.

Step	Description	Keys and Display
1	Program Mode <ul style="list-style-type: none"> Enter the password followed by the MODE key to access the program mode. Example: Password = 9000 Note: To exit the program mode, press the MODE key again. 	
2	Department Program Mode <ul style="list-style-type: none"> Press the DEPARTMENT key to skip this step. OR Enter "10" followed by the DOWN ARROW key. Press the ENTER key. 	
3	Department Code (4 digits) <ul style="list-style-type: none"> Enter the department code followed by the PLU key. Example: Department code = 1 5 	
4	Department Name or Delete <ul style="list-style-type: none"> Department Name (12 characters) <ul style="list-style-type: none"> Press the ENTER key. Enter the department name using the keyboard. Note: For text editing, refer to Chapter 4. When complete press the ENTER key. Delete <ul style="list-style-type: none"> Press the CHARACTER DELETE key to enter the delete mode. Press the CHARACTER DELETE key again to delete the specified department. Note: Press the ENTER key to cancel the deletion. 	

Step	Description	Keys and Display
5	Repeat <ul style="list-style-type: none"> Repeat steps 3 and 4 for any other departments. 	
6	Return to Initial Display <ul style="list-style-type: none"> When all department data has been programmed, press the END key. Press the MODE key to return to the initial display. 	 <p>The diagram illustrates the key sequence for returning to the initial display. It shows two buttons: 'END' on the left and 'MODE' on the right, with a right-pointing arrow between them. Below the buttons is a digital display. The top line of the display shows the text 'KEY IN ITEM No.' followed by a dark rectangular area. The bottom line of the display shows three '0.00' values separated by spaces.</p>

3.11 Group Codes and Names

Groups are used to link similar products together into a category for report purposes. The following steps show how to program a name for the reference number.

Note: Confirm that the Program Key Sheet, and not the Operation Key Sheet, is being used for this operation.

The displays shown below have both a character and a segment display. However, the AC-3000E has only a segment display.

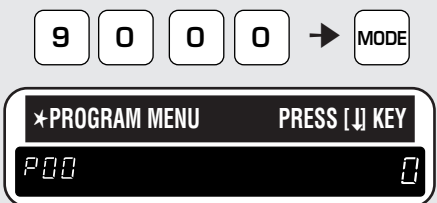
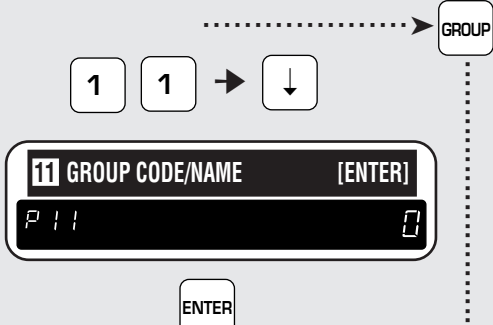
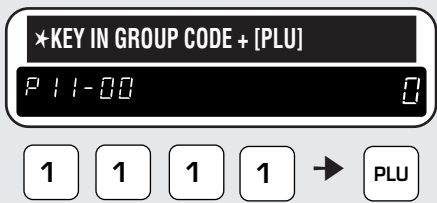
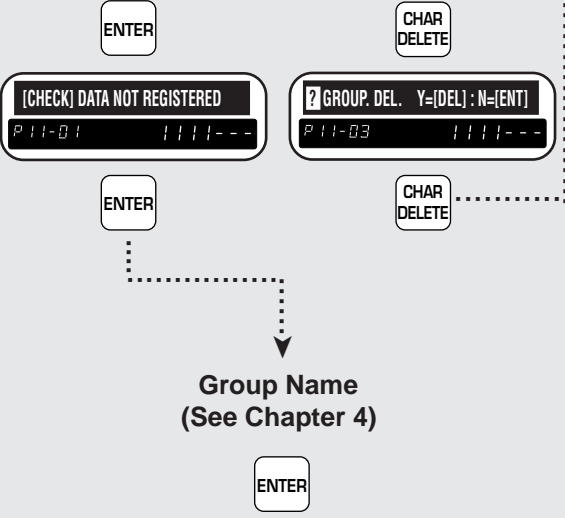
Step	Description	Keys and Display
1	<p>Program Mode</p> <ul style="list-style-type: none"> Enter the password followed by the MODE key to access the program mode. <p>Example: Password = 9 0 0 0</p> <p>Note: To exit the program mode, press the MODE key again.</p>	
2	<p>Group Mode</p> <ul style="list-style-type: none"> Press the GROUP key to skip this step. <p>OR</p> <ul style="list-style-type: none"> Enter "11" followed by the DOWN ARROW key. Press the ENTER key. 	
3	<p>Group Code (4 digits)</p> <ul style="list-style-type: none"> Enter the group code followed by the PLU key. <p>Example: Group code = 1 1 1 1</p> <ul style="list-style-type: none"> Press the ENTER key. 	
4	<p>Group Name or Deletion (12 characters)</p> <ul style="list-style-type: none"> Group Name (12 characters) <ul style="list-style-type: none"> Press the ENTER key. Enter the group name using the keyboard. <p>Note: For text editing, refer to Chapter 4.</p> When complete press the ENTER key. <ul style="list-style-type: none"> Deletion <ul style="list-style-type: none"> Press the CHARACTER DELETE key to enter the delete mode. Press the CHARACTER DELETE key again to delete the specified group. <p>Note: Press the ENTER key to cancel the deletion.</p> 	

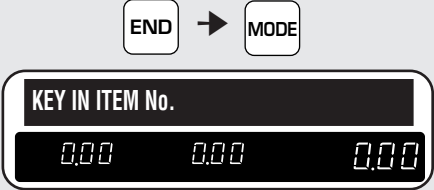

Step	Description	Keys and Display
5	Repeat <ul style="list-style-type: none"> Repeat steps 3 and 4 for any other group. 	
6	Return to Initial Display <ul style="list-style-type: none"> When all group data has been programmed, press the END key. Press the MODE key to return to the initial display. 	 <p>The diagram illustrates the key sequence for returning to the initial display. It shows two square buttons: 'END' on the left and 'MODE' on the right, with a right-pointing arrow between them. Below the buttons is a rectangular digital display. The top line of the display shows the text 'KEY IN ITEM No.' followed by a dark rectangular area. The bottom line of the display shows three numerical values, each '0.00', separated by spaces.</p>

3.12 Operator Codes and Names

The following steps show how to program operator codes and names used in the operator system.

Note: Confirm that the Program Key Sheet, and not the Operation Key Sheet, is being used for this operation.

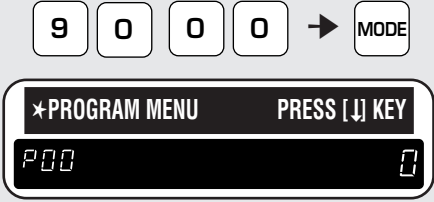
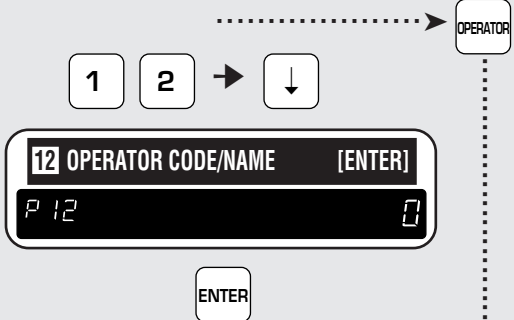
The displays shown below have both a character and a segment display. However, the AC-3000E has only a segment display.

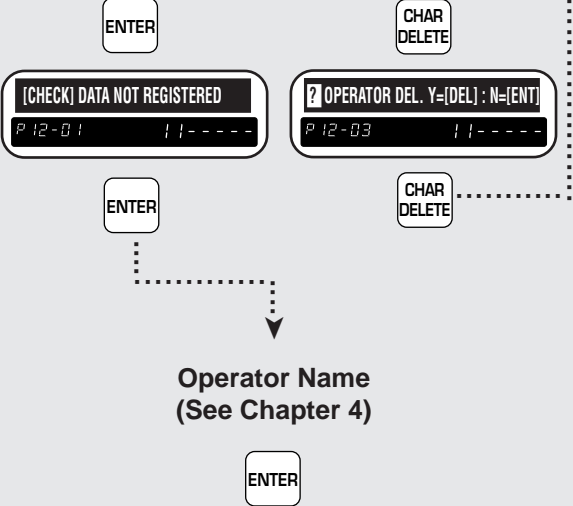
Step	Description	Keys and Display
1	<p>Program Mode</p> <ul style="list-style-type: none"> Enter the password followed by the MODE key to access the program mode. <p>Example: Password = 9 0 0 0</p> <p>Note: To exit the program mode, press the MODE key again.</p>	
2	<p>Operator Program Mode</p> <ul style="list-style-type: none"> Press the OPERATOR key to skip this step. <p>OR</p> <ul style="list-style-type: none"> Enter "12" followed by the DOWN ARROW key. Press the ENTER key. 	
3	<p>Operator Code (2 digits)</p> <ul style="list-style-type: none"> Enter the operator code followed by the PLU key. <p>Example: Operator code = 1 1</p>	
4	<p>Operator Name or Delete</p> <ul style="list-style-type: none"> Operator Name (12 characters) <ul style="list-style-type: none"> Press the ENTER key. Enter the operator name using the keyboard. <p>Note: For text editing, refer to Chapter 4.</p> When complete press the ENTER key. Delete <ul style="list-style-type: none"> Press the CHARACTER DELETE key to enter the delete mode. Press the CHARACTER DELETE key again to delete the specified operator. <p>Note: Press the ENTER key to cancel the deletion.</p> 	

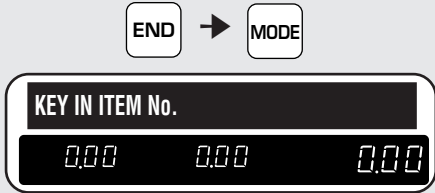
Step	Description	Keys and Display
5	Repeat <ul style="list-style-type: none"> Repeat steps 3 and 4 for any other operator. 	
6	Return to Initial Display <ul style="list-style-type: none"> When all operator data has been programmed, press the END key. Press the MODE key to return to the initial display. 	 <p>The diagram illustrates the key sequence and the resulting display. At the top, a box labeled 'END' has an arrow pointing to a box labeled 'MODE'. Below this, a rectangular display area is shown. The top part of the display contains the text 'KEY IN ITEM No.' followed by a blank space. The bottom part of the display shows three digital readouts, each displaying '0.00'.</p>



3.13 Advertisement Messages (AC-3000 only)

Up to 9 messages can be programmed and displayed (flashing or scrolling display). This procedure is used to program these messages and the times when the messages are to be displayed.

Note: Confirm that the Program Key Sheet, and not the Operation Key Sheet, is being used for this operation.

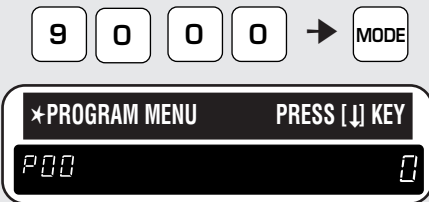
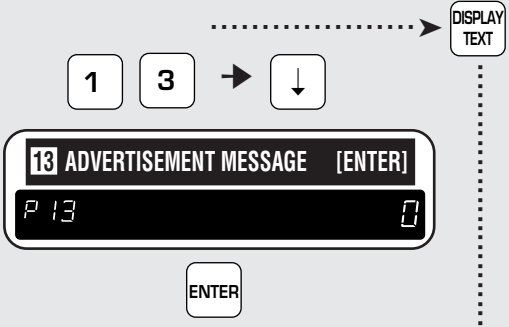
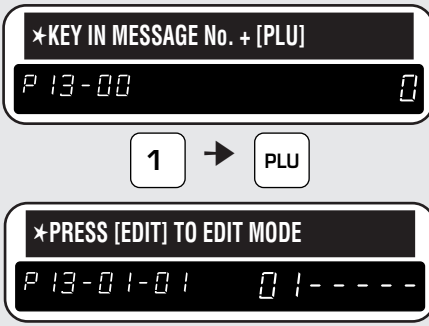
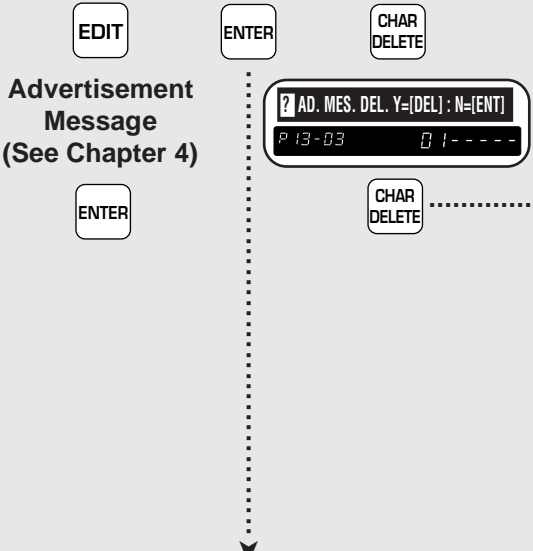
The displays shown below have both a character and a segment display. However, the AC-3000E has only a segment display.

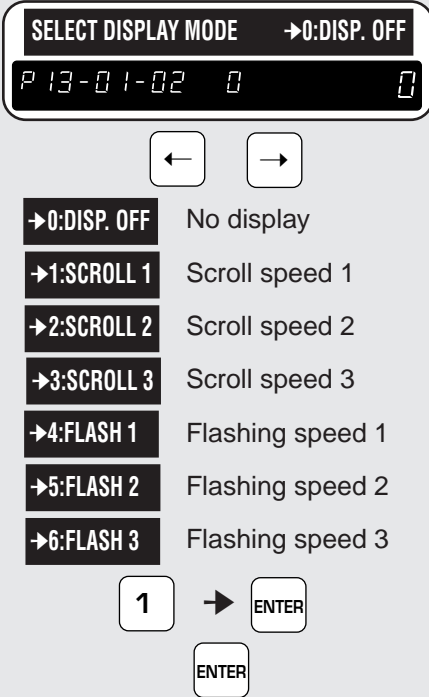
Step	Description	Keys and Display
1	<p>Program Mode</p> <ul style="list-style-type: none"> Enter the password followed by the MODE key to access the program mode. <p>Example: Password = 9 0 0 0</p> <p>Note: To exit the program mode, press the MODE key again.</p>	
2	<p>Message Program Mode</p> <ul style="list-style-type: none"> Press the DISPLAY TEXT key to skip this step. <p>OR</p> <ul style="list-style-type: none"> Enter "13" followed by the DOWN ARROW key. Press the ENTER key. 	
3	<p>Message Number (1 ~ 9)</p> <ul style="list-style-type: none"> Enter the message number followed by the PLU key. <p>Example: Message no. = 1</p>	
4	<p>Edit Mode or Delete</p> <ul style="list-style-type: none"> Text Edit (95 characters) <ul style="list-style-type: none"> Press the EDIT key. Enter the desired message using the keyboard. <p>Note: For text editing, refer to Chapter 4.</p> When complete, press the ENTER key. Skip This Step <ul style="list-style-type: none"> Press the ENTER key to skip this step. Delete <ul style="list-style-type: none"> Press the CHARACTER DELETE key to enter the delete mode. Press the CHARACTER DELETE key again to delete the specified message. 	

Step	Description	Keys and Display
5	<p>Screen Method</p> <ul style="list-style-type: none"> Use the LEFT ARROW or RIGHT ARROW key to view the desired type of display and speed. Select an appropriate number followed by the ENTER key. <p>Note: Speed 1 is fastest, speed 3 is slowest.</p> <p>Example: Scroll speed 1</p> <ul style="list-style-type: none"> Press the ENTER key. 	 <p>SELECT DISPLAY MODE →0:DISP. OFF</p> <p>P 13-01-02 0</p> <p>← →</p> <ul style="list-style-type: none"> →0:DISP. OFF No display →1:SCROLL 1 Scroll speed 1 →2:SCROLL 2 Scroll speed 2 →3:SCROLL 3 Scroll speed 3 →4:FLASH 1 Flashing speed 1 →5:FLASH 2 Flashing speed 2 →6:FLASH 3 Flashing speed 3 <p>1 → ENTER</p> <p>ENTER</p>
6	<p>Day of the Week</p> <ul style="list-style-type: none"> Use the LEFT ARROW or RIGHT ARROW key to view the day of the week when the message is to be displayed. Select an appropriate number followed by the ENTER key. <p>Example: Everyday</p> <ul style="list-style-type: none"> Press the ENTER key. 	 <p>SET DISPLAY DATE →0:EVERYDAY</p> <p>P 13-01-03 0</p> <p>← →</p> <ul style="list-style-type: none"> →0:EVERYDAY →1:SUNDAY →2:MONDAY →3:TUESDAY →4:WEDNESDAY →5:THURSDAY →6:FRIDAY →7:SATURDAY <p>0 → ENTER</p> <p>ENTER</p>
7	<p>Display Time (24 hour system)</p> <ul style="list-style-type: none"> Enter the desired time period when message is to be displayed. <p>Example: From 15:00 to 16:00</p> <ul style="list-style-type: none"> Press the ENTER key. 	 <p>TIME SCHEDULE (0)</p> <p>P 13-01-04</p> <p>1 5 1 6 → ENTER</p> <p>ENTER</p>

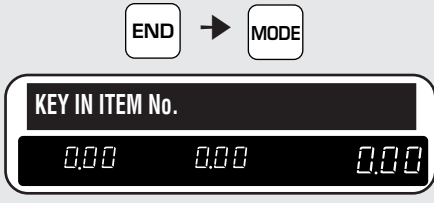
Step	Description	Keys and Display
8	Scroll Message Change <ul style="list-style-type: none"> Enter "1" and messages will be scrolled continuously in order. Enter "0" and each message will be scrolled independently for a set period of time. 	 <p>The diagram shows a rectangular display with two lines. The top line reads "CONSECUTIVE MESSAGE Y=1 N=0 (0)". The bottom line reads "P 13-01-05" followed by a small icon of a document with a checkmark. Below the display, there are three buttons: a button with the number "1", a button with a right-pointing arrow, and a button labeled "ENTER". Below the arrow button is another "ENTER" button.</p>
9	Return to Initial Display <ul style="list-style-type: none"> When the setting has been programmed, press the END key. Press the MODE key to return to the initial display. 	 <p>The diagram shows a rectangular display with two lines. The top line reads "KEY IN ITEM No.". The bottom line reads "000 000 000". Above the display, there are two buttons: a button labeled "END" and a button labeled "MODE", with a right-pointing arrow between them.</p>

3.14 Campaign Files

Campaign files are used to set a special price for a particular item and the period in which this special price is valid. The following procedure is used to program campaign files.

Note: Confirm that the Program Key Sheet, and not the Operation Key Sheet, is being used for this operation.

The displays shown below have both a character and a segment display. However, the AC-3000E has only a segment display.

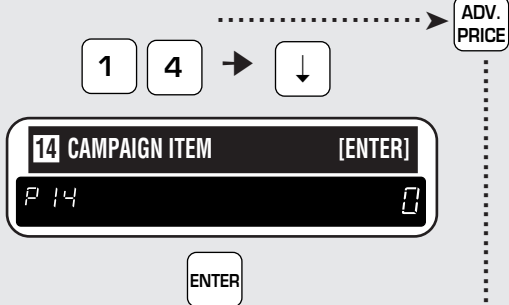
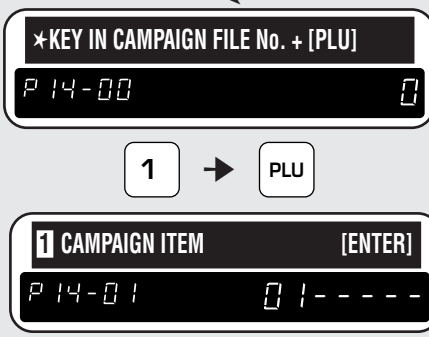
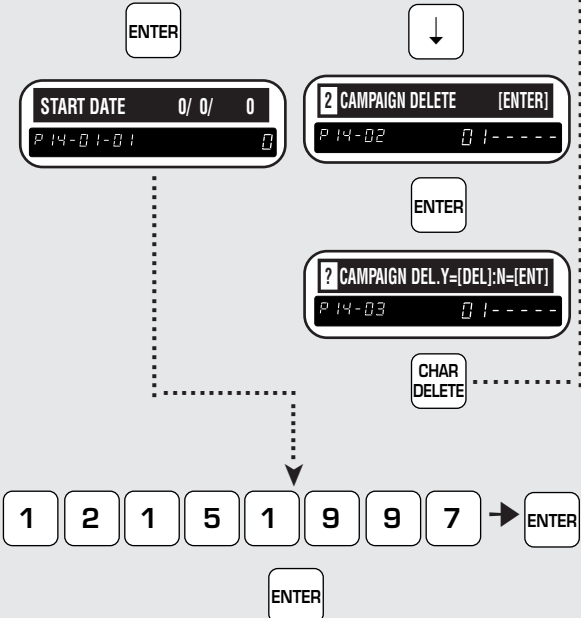
Step	Description	Keys and Display
1	Program Mode <ul style="list-style-type: none"> Enter the password followed by the MODE key to access the program mode. <p>Example: Password = 9 0 0 0</p> <p>Note: To exit the program mode, press the MODE key again.</p>	
2	Campaign Item Mode <ul style="list-style-type: none"> Press the ADVERTISEMENT PRICE key to skip this step. <p>OR</p> <ul style="list-style-type: none"> Enter "14" followed by the DOWN ARROW key. Press the ENTER key. 	
3	Select Campaign File (1 ~ 20) <ul style="list-style-type: none"> Enter the campaign file no. followed by the PLU key. <p>Example: File no. = 1</p>	
4	Start Date or Delete <ul style="list-style-type: none"> Start Date (MMDDYYYY) <ul style="list-style-type: none"> Press the ENTER key. Enter the start date followed by ENTER key. <p>Example: December 15, 1997</p> Press the ENTER key. Delete <ul style="list-style-type: none"> Press the DOWN ARROW key. Press the ENTER key to enter the delete mode. Press the CHARACTER DELETE key to delete the specified campaign file. <p>Note: Press the ENTER key to cancel the deletion.</p>	

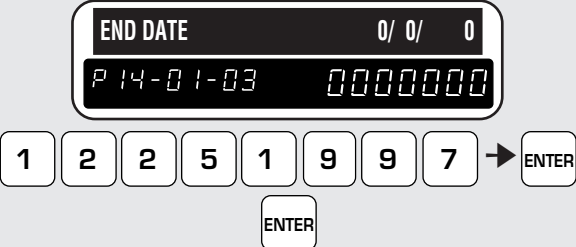
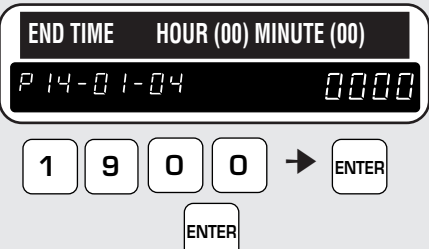
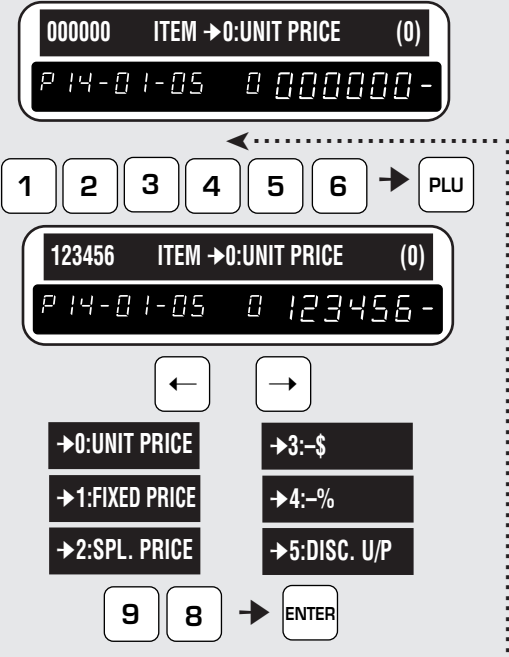
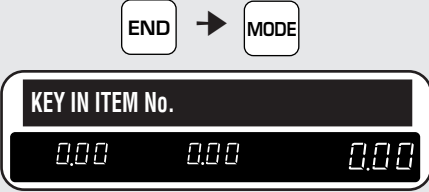

Step	Description	Keys and Display
5	Start Time (24 hour system) <ul style="list-style-type: none"> Enter the start time followed by the ENTER key. Example: 15:00 Press the ENTER key. 	
6	End Date (MMDDYYYY) <ul style="list-style-type: none"> Enter the end date followed by the ENTER key. Example: December 25, 1997 Press the ENTER key. 	
7	End Time (24 hour system) <ul style="list-style-type: none"> Enter the end time followed by the ENTER key. Example: 19:00 Press the ENTER key. 	
8	Campaign Item/Price <ul style="list-style-type: none"> Enter the PLU number followed by the PLU key. Example: PLU no. = 1 2 3 4 5 6 Unit price and fixed price are automatically selected based on PLU type. Select the type of discount using the LEFT ARROW or RIGHT ARROW key. Enter the price or rate followed by the ENTER key. Example: Special price = \$0.98 	
9	Repeat <ul style="list-style-type: none"> Repeat steps 3 and 8 for any other files. 	
10	Return to Initial Display <ul style="list-style-type: none"> When all files have been programmed, press the END key. Press the MODE key to return to the initial display. 	

3.15 Total Barcode

This program sets the barcode consisting of the flag code (2 digits) and department code (6 digits) to be printed on the receipt, or total label.

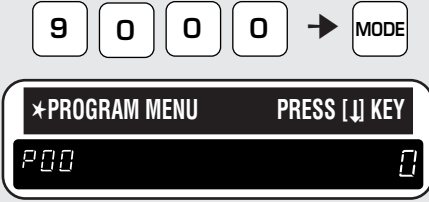
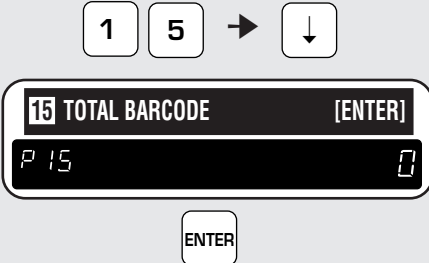

Note: Confirm that the Program Key Sheet, and not the Operation Key Sheet, is being used for this operation.

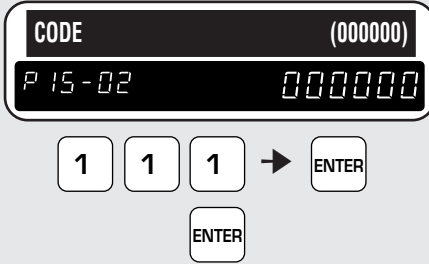
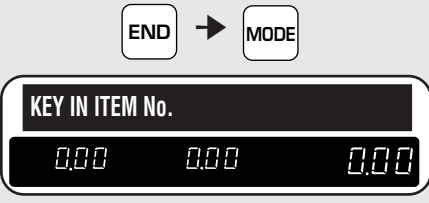
The displays shown below have both a character and a segment display. However, the AC-3000E has only a segment display.

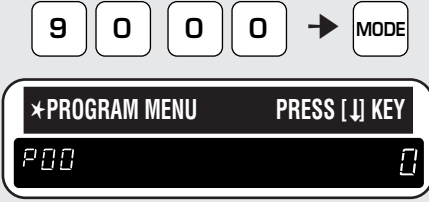
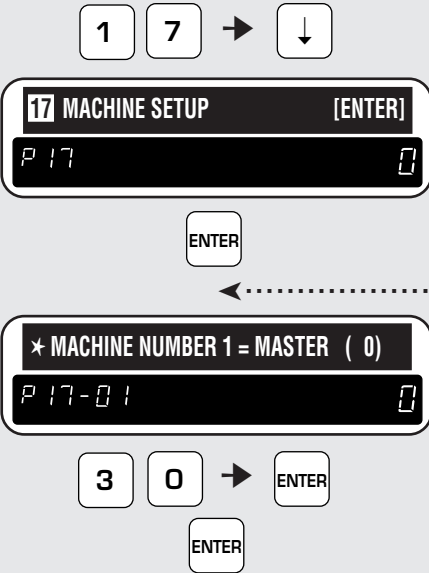
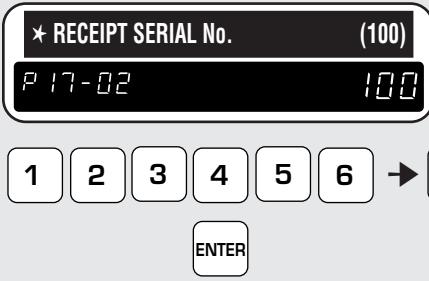

Step	Description	Keys and Display
1	<p>Program Mode</p> <ul style="list-style-type: none"> Enter the password followed by the MODE key to access the program mode. <p>Example: Password = 9 0 0 0</p> <p>Note: To exit the program mode, press the MODE key again.</p>	
2	<p>Total Barcode Mode</p> <ul style="list-style-type: none"> Enter "15" followed by the DOWN ARROW key. Press the ENTER key. 	
3	<p>UPC Prefix</p> <ul style="list-style-type: none"> Enter the UPC prefix (max. 2 digits) followed by ENTER key. <p>Example: UPC prefix = 1 0</p> <ul style="list-style-type: none"> Press the ENTER key. 	
4	<p>Department Code</p> <ul style="list-style-type: none"> Enter the department code (max. 6 digits) followed by ENTER key. <p>Example: Department code = 1 1 1</p> <ul style="list-style-type: none"> Press the ENTER key. 	
5	<p>Return to Initial Display</p> <ul style="list-style-type: none"> Press the END key and the MODE key to return to the initial display. 	

3.16 Other Programming

The displays shown below have both a character and a segment display. However, the AC-3000E has only a segment display.

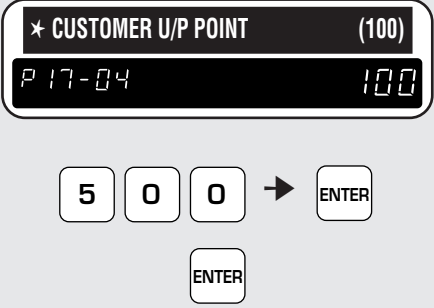
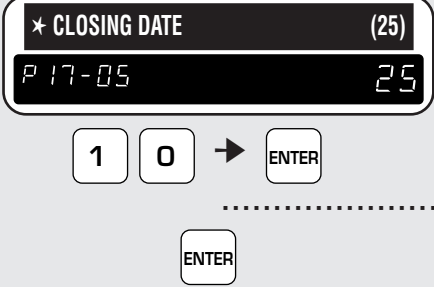
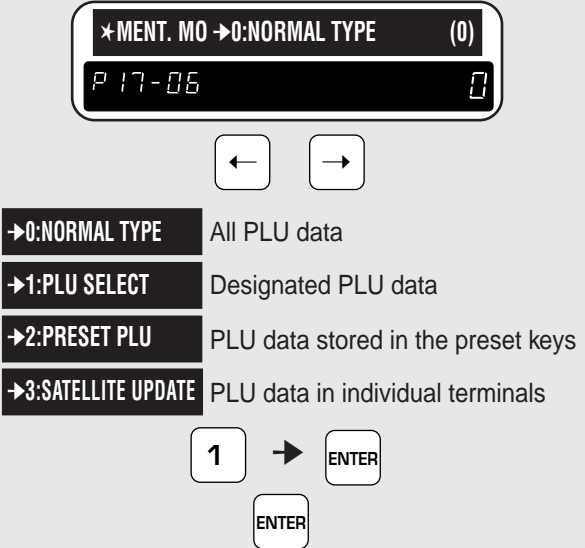
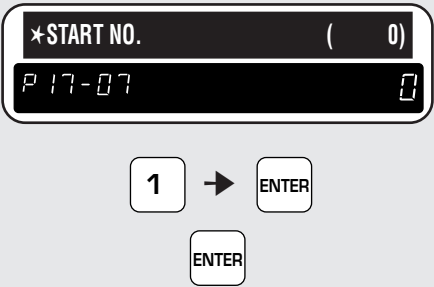
Step	Description	Keys and Display
1	<p>Program Mode</p> <ul style="list-style-type: none"> Enter the password followed by the MODE key to access the program mode. <p>Example: Password = 9 0 0 0</p> <p>Note: To exit the program mode, press the MODE key again.</p>	
2	<p>Machine Number (2 digits)</p> <p>This programming is only used for a master/satellite system. When the AC-3000/3000E is used as a stand-alone terminal, this step will be skipped.</p> <ul style="list-style-type: none"> Enter "17" followed by the DOWN ARROW key. Press the ENTER key. Enter the machine number followed by the ENTER key. <p>Note: For the master terminal, enter "1".</p> <p>Example: Satellite machine no. = 3 0</p> <ul style="list-style-type: none"> Press the ENTER key. 	
3	<p>Receipt Serial No. (max. 6 digits)</p> <p>Note: Skip this step when using label application.</p> <ul style="list-style-type: none"> Enter the receipt serial number followed by the ENTER key. <p>Example: Serial no. = 1 2 3 4 5 6</p> <ul style="list-style-type: none"> Press the ENTER key. 	
4	<p>Customer Pieces Point (max. 4 digits)</p> <p>This program determines a maximum of ten quantity zones. By using this program, the total report can be obtained in specific incremented zones.</p> <p>Note: Skip this step when using label application.</p> <ul style="list-style-type: none"> Enter the desired quantity point followed by the ENTER key. <p>Example: Point = 10 (1~10, 11~20, ..., and more than 91)</p> <ul style="list-style-type: none"> Press the ENTER key. 	

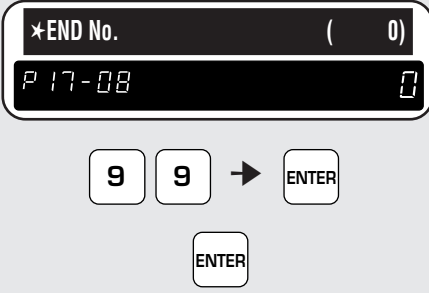
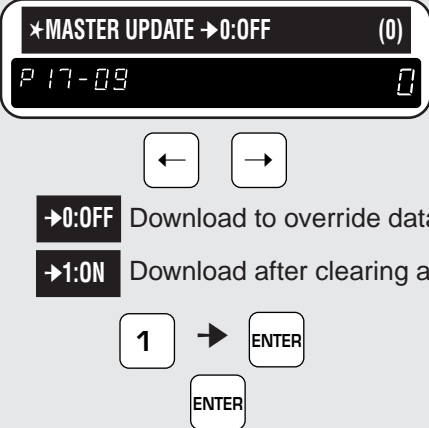
Step	Description	Keys and Display
5	<p>Customer Unit Price Point (max. 4 digits)</p> <p>This program determines a maximum of ten unit price zones. By using this program, the total report can be obtained in specific incremented zones.</p> <p>Note: Skip this step when using label application.</p> <ul style="list-style-type: none"> Enter the desired unit price point followed by the ENTER key. <p>Example: Point = \$5.00 (0.01~5.00, 5.01~10.00, ..., and more than 45.01)</p> <ul style="list-style-type: none"> Press the ENTER key. 	
6	<p>Closing Date (1 ~ 31)</p> <p>This programming is used to set a monthly closing date to serve as a reference for accounting purposes.</p> <ul style="list-style-type: none"> Enter the closing date followed by the ENTER key. <p>Example: Closing date = 1 0</p> <ul style="list-style-type: none"> Press the ENTER key. 	
7	<p>Data Selection</p> <p>This programming is used in a master/satellite system for automatic file downloading.</p> <ul style="list-style-type: none"> Use the LEFT ARROW or RIGHT ARROW key to view the type of data. Enter an appropriate number followed by the ENTER key to select the data. <p>Example: PLU select</p> <ul style="list-style-type: none"> Press the ENTER key. 	
8	<p>Start Number (6 digits)</p> <p>When performing PLU master downloading, this program sets the starting number of the PLU.</p> <ul style="list-style-type: none"> Enter the PLU start number followed by the ENTER key. <p>Example: Start no. = 1</p> <ul style="list-style-type: none"> Press the ENTER key. <p>Note: This step is only used when "PLU SELECT" has been selected at the step 7.</p>	

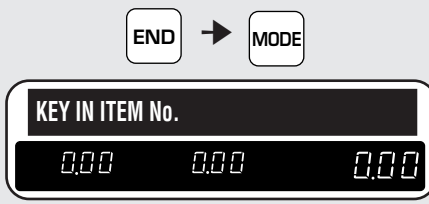

Step	Description	Keys and Display
9	<p>End Number (6 digits)</p> <p>When performing PLU master downloading, this program sets the ending number of the PLU.</p> <ul style="list-style-type: none"> Enter the PLU end number followed by the ENTER key. <p>Example: End no. = 9 9</p> <ul style="list-style-type: none"> Press the ENTER key. <p>Note: This step is only used when "PLU SELECT" has been selected at the step 7.</p>	 <p> *END No. (0) P 17-08 </p> <p>9 9 → ENTER</p> <p>ENTER</p>
10	<p>Downloading</p> <ul style="list-style-type: none"> Use the LEFT ARROW or RIGHT ARROW key to view the type of data. Enter an appropriate number followed by the ENTER key to select the downloading type. <ul style="list-style-type: none"> Then press the ENTER key. <p>Example: Download after clearing all data</p> <ul style="list-style-type: none"> Press the ENTER key. 	 <p> *MASTER UPDATE → 0:OFF (0) P 17-09 </p> <p>← →</p> <p>→ 0:OFF Download to override data</p> <p>→ 1:ON Download after clearing all data</p> <p>1 → ENTER</p> <p>ENTER</p>
11	<p>Automatic Execution Time (24 hour system)</p> <ul style="list-style-type: none"> Enter the time when file downloading is to be automatically executed, followed by the ENTER key. <p>Example: Execution time = 21:00</p>	 <p> *TIME (hh:mm) (0:00) P 00 </p> <p>2 1 0 0 → ENTER</p>
12	<p>Return to Initial Display</p> <ul style="list-style-type: none"> Press the END key and the MODE key to return to the initial display. 	 <p> END → MODE </p> <p> KEY IN ITEM No. 0.00 0.00 0.00 </p>

3.17 Setting On-line/Off-line

This procedure is used to switch between on-line and off-line programming.
This procedure is used only for a master/satellite system.

Note: Confirm that the Program Key Sheet, and not the Operation Key Sheet, is being used for this operation.

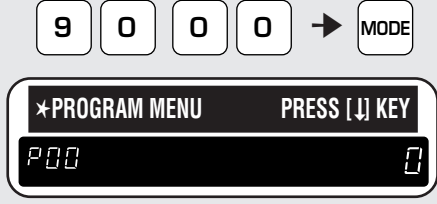
The displays shown below have both a character and a segment display. However, the AC-3000E has only a segment display.

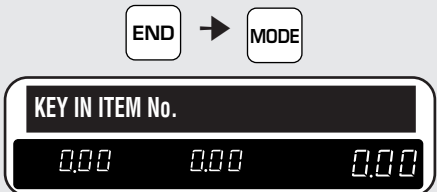

Step	Description	Keys and Display
1	<p>Program Mode</p> <ul style="list-style-type: none"> Enter the password followed by the MODE key to access the program mode. Example: Password = 9 0 0 0 <p>Note: To exit the program mode, press the MODE key again.</p>	
2	<p>On-line Setup Mode</p> <ul style="list-style-type: none"> Enter "19" followed by the DOWN ARROW key. Press the ENTER key. Use the LEFT ARROW or RIGHT ARROW key to view either on-line setup or off-line. Enter an appropriate number followed by the ENTER key to select the mode. <p>Example: On-line</p> <ul style="list-style-type: none"> Press the ENTER key. 	
3	<p>Return to Initial Display</p> <ul style="list-style-type: none"> When the selected setup has been programmed, press the END key. Press the MODE key to return to the initial display. 	



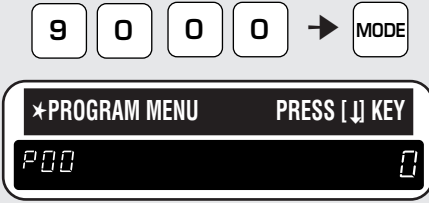

3.18 Master File Downloading

The AC-3000/3000E can be arranged in a master satellite configuration. With this procedure, designated data can be downloaded from the master file to a specific satellite terminal.

Note: Confirm that the Program Key Sheet, and not the Operation Key Sheet, is being used for this operation.

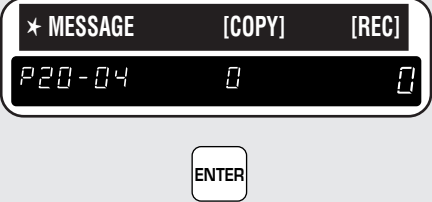
The displays shown below have both a character and a segment display. However, the AC-3000E has only a segment display.

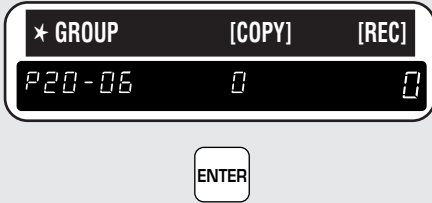
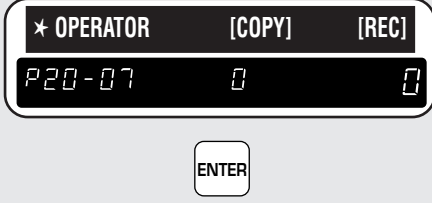
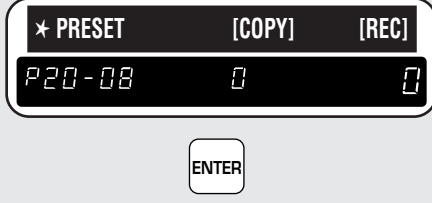
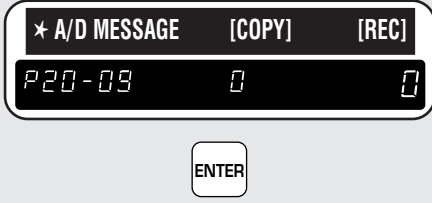
Step	Description	Keys and Display
1	<p>Program Mode</p> <ul style="list-style-type: none"> Enter the password followed by the MODE key to access the program mode. Example: Password = 9 0 0 0 <p>Note: To exit the program mode, press the MODE key again.</p>	
2	<p>Master File Maintenance</p> <ul style="list-style-type: none"> Enter "20" followed by the DOWN ARROW key. Press the ENTER key. Use the DOWN ARROW or UP ARROW key to select an appropriate screen. <p>▪ PLU Master File</p> <ul style="list-style-type: none"> Press the ENTER key. <p>▪ Store Master File</p> <ul style="list-style-type: none"> Press the ENTER key. <p>▪ Coupon Message Master File</p> <ul style="list-style-type: none"> Press the ENTER key. 	 <p>[REC] Downloading is being executed. [OK] Downloading has been completed. [NG] Downloading has failed.</p>

Step	Description	Keys and Display
	<ul style="list-style-type: none"> ▪ Extra Message Master File <ul style="list-style-type: none"> • Press the ENTER key. 	
	<ul style="list-style-type: none"> ▪ Department Master File <ul style="list-style-type: none"> • Press the ENTER key. 	
	<ul style="list-style-type: none"> ▪ Group Master File <ul style="list-style-type: none"> • Press the ENTER key. 	
	<ul style="list-style-type: none"> ▪ Operator Master File <ul style="list-style-type: none"> • Press the ENTER key. 	
	<ul style="list-style-type: none"> ▪ Preset Key Master File <ul style="list-style-type: none"> • Press the ENTER key. 	
	<ul style="list-style-type: none"> ▪ Advertisement Message Master File <ul style="list-style-type: none"> • Press the ENTER key. 	
	<ul style="list-style-type: none"> ▪ Title Master File <ul style="list-style-type: none"> • Press the ENTER key. 	



Step	Description	Keys and Display
	<ul style="list-style-type: none"> ▪ Tax Master File <p style="margin-left: 20px;"><i>Note: This function is only available in the receipt application.</i></p> <ul style="list-style-type: none"> • Press the ENTER key. ▪ Campaign Master File <ul style="list-style-type: none"> • Press the ENTER key. ▪ Price Change Batch Master File <ul style="list-style-type: none"> • Press the ENTER key. ▪ Receipt Bar Master File <p style="margin-left: 20px;"><i>Note: This function is only available in the receipt application.</i></p> <ul style="list-style-type: none"> • Press the ENTER key. ▪ Subtotal Data Master File <ul style="list-style-type: none"> • Press the ENTER key. ▪ Nutrition Data Master File <ul style="list-style-type: none"> • Press the ENTER key. 	<div style="text-align: center; border: 1px solid black; padding: 5px; margin-bottom: 10px;"> <p>★ TAX MASTER [COPY] [REC]</p> <p>P20-11 0 0</p> <p>ENTER</p> </div> <hr style="border-top: 1px dashed black;"/> <div style="text-align: center; border: 1px solid black; padding: 5px; margin-bottom: 10px;"> <p>★ CAMPAIGN [COPY] [REC]</p> <p>P20-12 0 0</p> <p>ENTER</p> </div> <hr style="border-top: 1px dashed black;"/> <div style="text-align: center; border: 1px solid black; padding: 5px; margin-bottom: 10px;"> <p>★ BATCH [COPY] [REC]</p> <p>P20-13 0 0</p> <p>ENTER</p> </div> <hr style="border-top: 1px dashed black;"/> <div style="text-align: center; border: 1px solid black; padding: 5px; margin-bottom: 10px;"> <p>★ RECEIPT BAR [COPY] [REC]</p> <p>P20-14 0 0</p> <p>ENTER</p> </div> <hr style="border-top: 1px dashed black;"/> <div style="text-align: center; border: 1px solid black; padding: 5px; margin-bottom: 10px;"> <p>★ SUB TOTAL [COPY] [REC]</p> <p>P20-15 0 0</p> <p>ENTER</p> </div> <hr style="border-top: 1px dashed black;"/> <div style="text-align: center; border: 1px solid black; padding: 5px; margin-bottom: 10px;"> <p>★ NUTRITION [COPY] [REC]</p> <p>P20-16 0 0</p> <p>ENTER</p> </div>
3	<p>Return to Initial Display</p> <ul style="list-style-type: none"> • When downloading has been completed, press the END key. • Press the MODE key to return to the initial display. 	<div style="text-align: center; margin-bottom: 10px;"> <p>END → MODE</p> </div> <div style="text-align: center; border: 1px solid black; padding: 5px;"> <p>KEY IN ITEM No.</p> <p>0.00 0.00 0.00</p> </div>





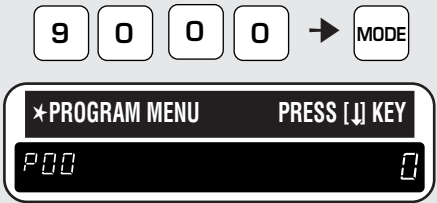

3.19 Nutrition Files

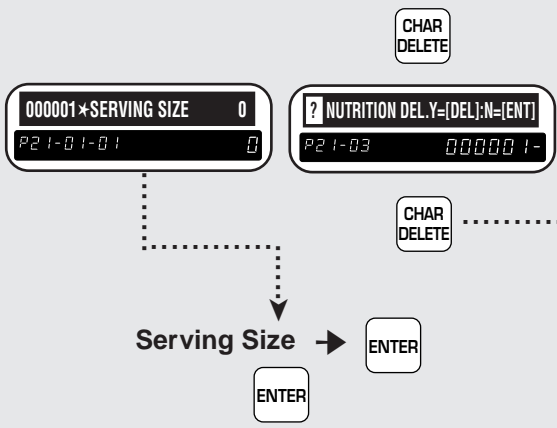
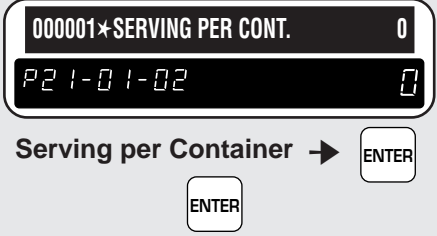
Nutrition Files can be included with each PLU. This procedure is used to program Nutrition Files to be linked with the PLUs.

Note: Confirm that the Program Key Sheet, and not the Operation Key Sheet, is being used for this operation.

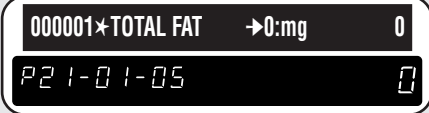

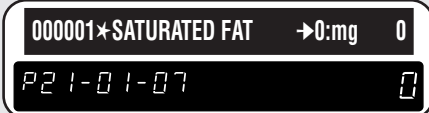
The displays shown below have both a character and a segment display. However, the AC-3000E has only a segment display.

Step	Description	Keys and Display
1	Program Mode <ul style="list-style-type: none"> Enter the password followed by the MODE key to access the program mode. Example: Password = 9 0 0 0 Note: To exit the program mode, press the MODE key again. 	
2	Nutrition File <ul style="list-style-type: none"> Enter "21" followed by the DOWN ARROW key. Press the ENTER key. 	
3	PLU Number <ul style="list-style-type: none"> Enter the PLU number followed by the PLU key. Example: PLU no. = 1 	
4	Serving Size or Delete <ul style="list-style-type: none"> Serving Size (10 characters) <ul style="list-style-type: none"> Enter "Serving Size" followed by the ENTER key. Press the ENTER key. Delete <ul style="list-style-type: none"> Press the CHARACTER DELETE key to enter the delete mode. Press the CHARACTER DELETE key again to delete the specified file. <p>Note: Press the ENTER key to cancel the deletion.</p>	
5	Serving per Container (4 characters) <ul style="list-style-type: none"> Enter "Serving per Container" followed by the ENTER key. Press the ENTER key. <p>Note: The entered data will be printed when issuing nutrition label for fixed price items. For the weighed items, "varies" will always be printed.</p>	

Step	Description	Keys and Display
6	Total Calories (4 digits) <ul style="list-style-type: none"> Enter "Total Calories" followed by the ENTER key. Press the ENTER key. 	 <p>Total Calories → ENTER</p> <p>ENTER</p>
7	Calories from Fat (4 digits) <ul style="list-style-type: none"> Enter "Calories from Fat" followed by the ENTER key. Press the ENTER key. 	 <p>Calories from Fat → ENTER</p> <p>ENTER</p>
8	Total Fat (3 characters) <ul style="list-style-type: none"> Select the unit of weight ("mg" or "g") by using the LEFT ARROW or RIGHT ARROW key.  <ul style="list-style-type: none"> Enter "Total Fat" followed by the ENTER key. Press the ENTER key. 	 <p>Select "mg" or "g"</p> <p>← OR →</p> <p>Total Fat → ENTER</p> <p>ENTER</p>
9	Total Fat Percentage (3 digits) <ul style="list-style-type: none"> Enter "Total Fat Percentage" followed by the ENTER key. Press the ENTER key. 	 <p>Total Fat % → ENTER</p> <p>ENTER</p>
10	Saturated Fat (3 characters) <ul style="list-style-type: none"> Select the unit of weight ("mg" or "g") by using the LEFT ARROW or RIGHT ARROW key.  <ul style="list-style-type: none"> Enter "Saturated Fat" followed by the ENTER key. Press the ENTER key. 	 <p>Select "mg" or "g"</p> <p>← OR →</p> <p>Saturated Fat → ENTER</p> <p>ENTER</p>
11	Saturated Fat Percentage (3 digits) <ul style="list-style-type: none"> Enter "Saturated Fat Percentage" followed by the ENTER key. Press the ENTER key. 	 <p>Saturated Fat % → ENTER</p> <p>ENTER</p>

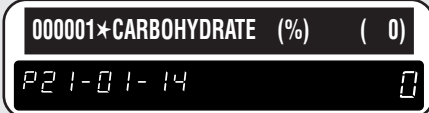
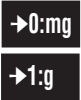
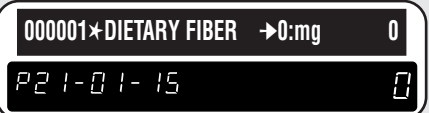
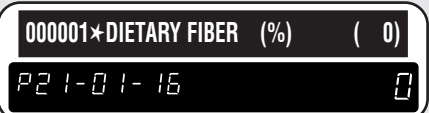
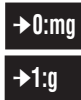
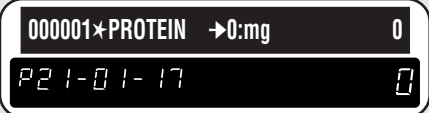
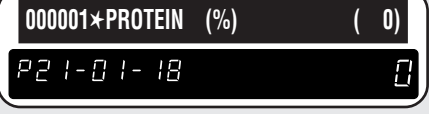
Step	Description	Keys and Display
12	<p>Cholesterol (3 characters)</p> <ul style="list-style-type: none"> Select the unit of weight (“mg” or “g”) by using the LEFT ARROW or RIGHT ARROW key. <div style="display: flex; flex-direction: column; align-items: center;"> <div style="border: 1px solid black; padding: 2px; margin: 2px;">→0:mg</div> <div style="border: 1px solid black; padding: 2px; margin: 2px;">→1:g</div> </div> <ul style="list-style-type: none"> Enter “Cholesterol” followed by the ENTER key. Press the ENTER key. 	<div style="border: 1px solid black; padding: 5px; margin-bottom: 10px;"> <p>000001*CHOLESTEROL →0:mg 0</p> <p>P21-01-09</p> </div> <p>Select “mg” or “g”</p> <div style="display: flex; align-items: center; gap: 10px;"> ← OR → </div> <p>Cholesterol → ENTER</p> <div style="display: flex; justify-content: center; gap: 20px;"> <div style="border: 1px solid black; padding: 2px;">ENTER</div> <div style="border: 1px solid black; padding: 2px;">ENTER</div> </div>
13	<p>Cholesterol Percentage (3 digits)</p> <ul style="list-style-type: none"> Enter “Cholesterol Percentage” followed by the ENTER key. Press the ENTER key. 	<div style="border: 1px solid black; padding: 5px; margin-bottom: 10px;"> <p>000001*CHOLESTEROL (%) (0)</p> <p>P21-01-10</p> </div> <p>Cholesterol % → ENTER</p> <div style="display: flex; justify-content: center; gap: 20px;"> <div style="border: 1px solid black; padding: 2px;">ENTER</div> <div style="border: 1px solid black; padding: 2px;">ENTER</div> </div>
14	<p>Sodium (4 characters)</p> <ul style="list-style-type: none"> Select the unit of weight (“mg” or “g”) by using the LEFT ARROW or RIGHT ARROW key. <div style="display: flex; flex-direction: column; align-items: center;"> <div style="border: 1px solid black; padding: 2px; margin: 2px;">→0:mg</div> <div style="border: 1px solid black; padding: 2px; margin: 2px;">→1:g</div> </div> <ul style="list-style-type: none"> Enter “Sodium” followed by the ENTER key. Press the ENTER key. 	<div style="border: 1px solid black; padding: 5px; margin-bottom: 10px;"> <p>000001*SODIUM →0:mg 0</p> <p>P21-01-11</p> </div> <p>Select “mg” or “g”</p> <div style="display: flex; align-items: center; gap: 10px;"> ← OR → </div> <p>Sodium → ENTER</p> <div style="display: flex; justify-content: center; gap: 20px;"> <div style="border: 1px solid black; padding: 2px;">ENTER</div> <div style="border: 1px solid black; padding: 2px;">ENTER</div> </div>
15	<p>Sodium Percentage (3 digits)</p> <ul style="list-style-type: none"> Enter “Sodium Percentage” followed by the ENTER key. Press the ENTER key. 	<div style="border: 1px solid black; padding: 5px; margin-bottom: 10px;"> <p>000001*SODIUM (%) (0)</p> <p>P21-01-12</p> </div> <p>Sodium % → ENTER</p> <div style="display: flex; justify-content: center; gap: 20px;"> <div style="border: 1px solid black; padding: 2px;">ENTER</div> <div style="border: 1px solid black; padding: 2px;">ENTER</div> </div>
16	<p>Carbohydrate (4 characters)</p> <ul style="list-style-type: none"> Select the unit of weight (“mg” or “g”) by using the LEFT ARROW or RIGHT ARROW key. <div style="display: flex; flex-direction: column; align-items: center;"> <div style="border: 1px solid black; padding: 2px; margin: 2px;">→0:mg</div> <div style="border: 1px solid black; padding: 2px; margin: 2px;">→1:g</div> </div> <ul style="list-style-type: none"> Enter “Total Carbohydrate” followed by the ENTER key. Press the ENTER key. 	<div style="border: 1px solid black; padding: 5px; margin-bottom: 10px;"> <p>000001*CARBOHYDRATE →0:mg 0</p> <p>P21-01-13</p> </div> <p>Select “mg” or “g”</p> <div style="display: flex; align-items: center; gap: 10px;"> ← OR → </div> <p>Total Carbohydrate → ENTER</p> <div style="display: flex; justify-content: center; gap: 20px;"> <div style="border: 1px solid black; padding: 2px;">ENTER</div> <div style="border: 1px solid black; padding: 2px;">ENTER</div> </div>

Step	Description	Keys and Display
17	Carbohydrate Percentage (3 digits) <ul style="list-style-type: none"> Enter "Total Carbohydrate Percentage" followed by the ENTER key. Press the ENTER key. 	 <p>Total Carbohydrate % → ENTER</p> <p>ENTER</p>
18	Dietary Fiber (3 characters) <ul style="list-style-type: none"> Select the unit of weight ("mg" or "g") by using the LEFT ARROW or RIGHT ARROW key.  <ul style="list-style-type: none"> Enter "Dietary Fiber" followed by the ENTER key. Press the ENTER key. 	 <p>Select "mg" or "g"</p> <p>← OR →</p> <p>Dietary Fiber → ENTER</p> <p>ENTER</p>
19	Dietary Fiber Percentage (3 digits) <ul style="list-style-type: none"> Enter "Dietary Fiber Percentage" followed by the ENTER key. Press the ENTER key. 	 <p>Dietary Fiber % → ENTER</p> <p>ENTER</p>
20	Protein (3 characters) <ul style="list-style-type: none"> Select the unit of weight ("mg" or "g") by using the LEFT ARROW or RIGHT ARROW key.  <ul style="list-style-type: none"> Enter "Protein" followed by the ENTER key. Press the ENTER key. 	 <p>Select "mg" or "g"</p> <p>← OR →</p> <p>Protein → ENTER</p> <p>ENTER</p>
21	Protein Percentage (3 digits) <ul style="list-style-type: none"> Enter "Protein Percentage" followed by the ENTER key. Press the ENTER key. 	 <p>Protein % → ENTER</p> <p>ENTER</p>

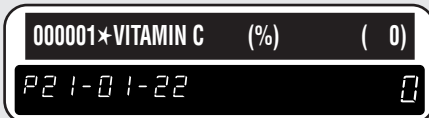
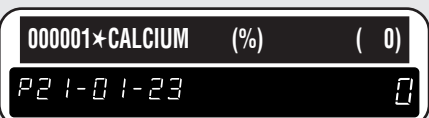
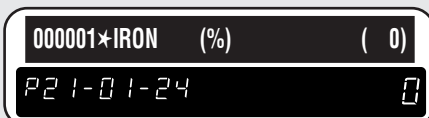
Step	Description	Keys and Display
22	<p>Sugars (3 characters)</p> <ul style="list-style-type: none"> Select the unit of weight (“mg” or “g”) by using the LEFT ARROW or RIGHT ARROW key. Enter “Sugars” followed by the ENTER key. Press the ENTER key. 	 <p>Select “mg” or “g”</p> <p>← OR →</p> <p>Sugars → ENTER</p> <p>ENTER</p>
23	<p>Sugars Percentage (3 digits)</p> <ul style="list-style-type: none"> Enter “Sugars Percentage” followed by the ENTER key. Press the ENTER key. 	 <p>Sugars % → ENTER</p> <p>ENTER</p>
24	<p>Vitamin A Percentage (3 digits)</p> <ul style="list-style-type: none"> Enter “Vitamin A Percentage” followed by the ENTER key. Press the ENTER key. 	 <p>Vitamin A % → ENTER</p> <p>ENTER</p>
25	<p>Vitamin C Percentage (3 digits)</p> <ul style="list-style-type: none"> Enter “Vitamin C Percentage” followed by the ENTER key. Press the ENTER key. 	 <p>Vitamin C % → ENTER</p> <p>ENTER</p>
26	<p>Calcium Percentage (3 digits)</p> <ul style="list-style-type: none"> Enter “Calcium Percentage” followed by the ENTER key. Press the ENTER key. 	 <p>Calcium % → ENTER</p> <p>ENTER</p>
27	<p>Iron Percentage (3 digits)</p> <ul style="list-style-type: none"> Enter “Iron Percentage” followed by the ENTER key. Press the ENTER key. 	 <p>Iron % → ENTER</p> <p>ENTER</p>

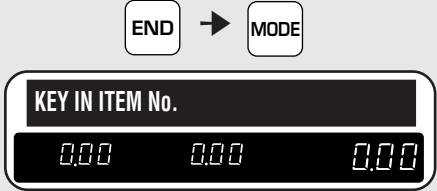
Step	Description	Keys and Display
28	Repeat <ul style="list-style-type: none"> Repeat steps 3 and 27 for any other nutrition files. 	
29	Return to Initial Display <ul style="list-style-type: none"> When all files have been programmed, press the END key. Press the MODE key to return to the initial display. 	 <p>The diagram illustrates the key sequence and the resulting display. At the top, there is a button labeled 'END' followed by a right-pointing arrow and a button labeled 'MODE'. Below this, a digital display is shown with the text 'KEY IN ITEM No.' at the top. Underneath the text, there are three numerical values, each displayed as '0.00'.</p>

3.20 Changing Unit Price/Fixed Price

This procedure is used to change either the PLU unit price or fixed price when the AC-3000/3000E is used on-line.

Note: Confirm that the Program Key Sheet, and not the Operation Key Sheet, is being used for this operation.

The displays shown below have both a character and a segment display. However, the AC-3000E has only a segment display.

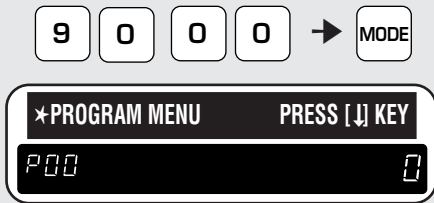
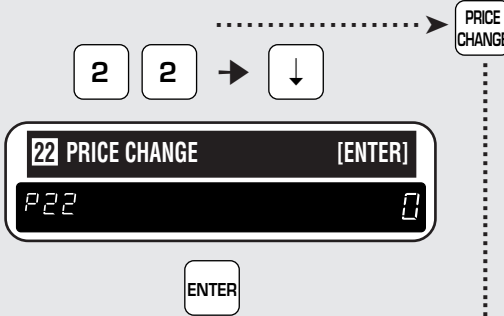
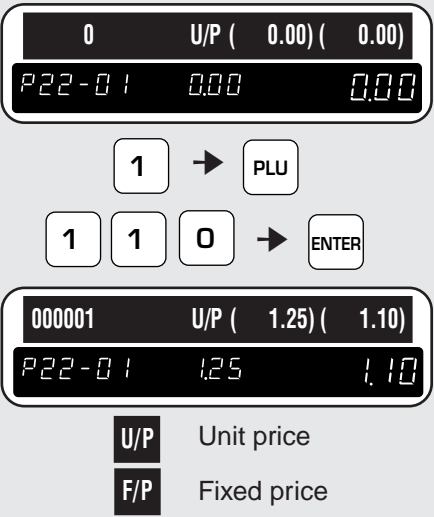
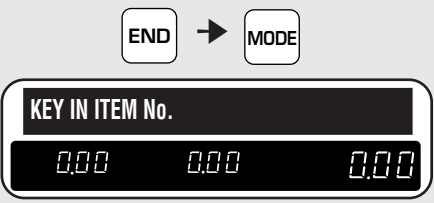
Step	Description	Keys and Display
1	Program Mode <ul style="list-style-type: none"> Enter the password followed by the MODE key to access the program mode. <p>Example: Password = 9 0 0 0</p> <p>Note: To exit the program mode, press the MODE key again.</p>	
2	Price Change Mode <ul style="list-style-type: none"> Press the PRICE CHANGE key to skip this step. <p>OR</p> <ul style="list-style-type: none"> Enter "22" followed by the DOWN ARROW key. Press the ENTER key. 	
3	Price Change <ul style="list-style-type: none"> Enter the PLU no. followed by the PLU key. <p>Example: PLU no. = 1</p> <ul style="list-style-type: none"> Enter the new price followed by the ENTER key. <p>Example: Current unit price = \$1.25 New unit price = \$1.10</p>	
4	Repeat <ul style="list-style-type: none"> Repeat step 3 for any other prices to be changed. 	
5	Return to Initial Display <ul style="list-style-type: none"> When all prices have been changed, press the END key. Press the MODE key to return to the initial display. 	

CHAPTER 4

TEXT EDITING

Contents

4.1	7-Segment Indicators	80
4.2	Character Size	80
4.3	Text Editing Keys	81
4.4	How to Create/Edit Text	82
4.5	How to Reverse/Italic/Underline/ Bold Text	83
4.6	How to Insert Characters	85
4.7	How to Change Characters	86
4.8	How to Delete Characters	87

4.1 7-Segment Indicators

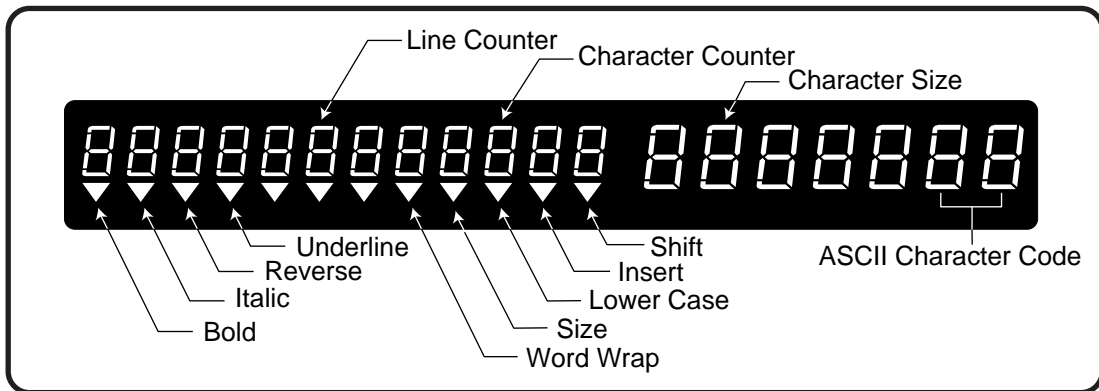

4.2 Character Size

The following text can be entered while in the Editing mode.

Variable Character Size

- PLU name
- Extra message
- Store name
- Coupon message

Fixed Character Size

- Department name (max. 12 characters)
- Group name (max. 12 characters)
- Operator name (max. 12 characters)
- Store address (max. 47 characters)

Character Size based on 60 mm (2.4 inch) word wrap		Print Examples
Size 1	7 × 14 dots (Upper/Lower case) Max. 48 characters/line	
Size 2	10 × 20 dots (Upper case only) Max. 36 characters/line	
Size 3	15 × 30 dots (Upper case only) Max. 25 characters/line	
Size 4	20 × 40 dots (Upper case only) Max. 18 characters/line	
Size 5	30 × 60 dots (Upper case only) Max. 12 characters/line	
Size 6	40 × 80 dots (Upper case only) Max. 9 characters/line	
Size 7	60 × 120 dots (Upper case only) Max. 6 characters/line	

4.3 Text Editing Keys

Use the following Text Editing keys (located on the Program Key Sheet) when creating, editing or deleting text.

Alpha-numeric Keys

The Program Key Sheet comes with a typewriter style keyboard to enter data into fields available.



SHIFT

Used to access the upper character of keys with two characters.
Used with the arrow keys to quickly move to the beginning or end of a PLU description line.



LOWER CASE

Used to change upper or lower case characters.
Available for front size 1 only (smallest).

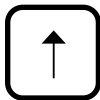

UP ARROW

Used to move the cursor up one line and over to the left margin. Also used to move up the cursor several lines at one time by first pressing the SHIFT key, then entering the number of lines.

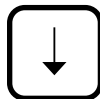

DOWN ARROW

Used to move the cursor down one line and over to the left margin. Also used to move down the cursor several lines at one time by first pressing the SHIFT key then entering the number of lines.



LEFT ARROW

Used to move the cursor one space to the left.



RIGHT ARROW

Used to move the cursor one space to the right.



EDIT

Used to enter the text entry mode for any text field.



NEW LINE

Used as a carriage return when in the text edit mode.



BACK SPACE

Used to delete the last entered character.



CHARACTER DELETE

Used to delete the character where cursor is placed on the display from text field.



LINE DELETE

Used to delete an entire line from text field.



INSERT

Used to change between inserting or overriding characters in editing of any text field.



NORMAL

Used to return to normal type (character size remains unchanged).



ITALIC

Used to switch to italic type.
Also used to return italic type to normal type.



UNDERLINE

Used to switch to underline type.
Also used to return underline type to normal type.



REVERSE

Used to switch to reverse type.
Also used to return reverse type to normal type.



BOLD

Used to switch to bold type.
Also used to return bold type to normal type.



SIZE

Used in combination with the UP ARROW or DOWN ARROW key to select character sizes.



COPY

Used to copy messages such as product name, extra message, and coupon message etc.











WORD WRAP

Used to select primary or secondary word wrap width when using a PLU message or extra text message.







4.4 How to Create/Edit Text



The displays shown below have both a character and a segment display. However, the AC-3000E has only a segment display.

Step	Description	Keys and Display
1	Text Edit Mode <ul style="list-style-type: none"> Make sure that the AC-3000/3000E is in the text edit mode. 	 <p style="text-align: center;">↑ Character size</p>
2	Character Size of the First Line <ul style="list-style-type: none"> Press the SIZE key, and the size indicator will light. Press the UP ARROW or DOWN ARROW key to select the desired character size (1 ~ 7). Example: Size 3 Press the SIZE key again to determine the character size. 	<p style="text-align: center;">SIZE</p> <p style="text-align: center;">↑ OR ↓</p>  <p style="text-align: center;">SIZE</p> <p style="text-align: center;">SIZE</p>
3	Text on the First Line <ul style="list-style-type: none"> Enter the desired text on the 1st line. <p style="text-align: center;">Example: FILET MIGNON</p>	<p style="text-align: center;">F I L E T</p>  <p style="text-align: center;">SPACE M I G N O N</p> 
4	Character Size of the New Line <ul style="list-style-type: none"> Press the NEW LINE Key. Press the SIZE Key. Select the desired character size by pressing the UP or DOWN key. Example: Size 2 Press the SIZE key again to determine the character size. 	<p style="text-align: center;">NEW LINE</p>  <p style="text-align: center;">SIZE</p> <p style="text-align: center;">↑ OR ↓</p>  <p style="text-align: center;">SIZE</p>
5	Text on the New Line <ul style="list-style-type: none"> Enter the desired text on the 2nd line. <p style="text-align: center;">Example: ((BEEF))</p> <ul style="list-style-type: none"> Press the ENTER key. 	<p style="text-align: center;">((B E E F))</p>  <p style="text-align: center;">ENTER</p>
6	Print <ul style="list-style-type: none"> Press the PRINT key to confirm the entered text. 	<p style="text-align: center;">PRINT</p> 

4.5 How to Reverse/Italic/Underline/Bold Text

The displays shown below have both a character and a segment display. However, the AC-3000E has only a segment display.

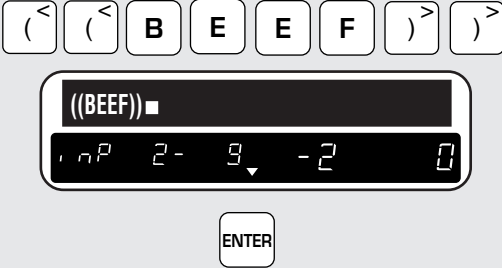
Step	Description	Keys and Display
1	<p>Text Edit Mode</p> <ul style="list-style-type: none"> Make sure that the AC-3000/3000E is in the text edit mode. 	 <p style="text-align: center;">↑ Character size</p>
2	<p>Character Size of the First Line</p> <ul style="list-style-type: none"> Press the SIZE key, and the size indicator will light. Press the UP ARROW or DOWN ARROW key to select the desired character size (1 ~ 7). Example: Size 3 Press the SIZE key again to determine the character size. 	<p style="text-align: center;">SIZE</p> <p style="text-align: center;">↑ OR ↓</p>  <p style="text-align: center;">SIZE</p> <p style="text-align: center;">SIZE</p>
3	<p>Reverse Text on the First Line</p> <ul style="list-style-type: none"> Press the REVERSE key to select text reverse mode, and the REVERSE indicator will light. <p>Note: At this point, <i>ITALIC</i>, <i>BOLD</i>, and <i>UNDERLINE</i> keys can also be used.</p> <ul style="list-style-type: none"> Enter the desired text on the 1st line. <p style="text-align: center;">Example: FILET MIGNON</p> <ul style="list-style-type: none"> Press the NORMAL key, or press the REVERSE key again to return to standard text. 	<p style="text-align: center;">REVERSE</p>  <p style="text-align: center;">↑ Reverse</p> <p style="text-align: center;">F I L E T</p>  <p style="text-align: center;">SPACE M I G N O N</p>  <p style="text-align: center;">REVERSE OR NORMAL</p>
4	<p>Character Size of the New Line</p> <ul style="list-style-type: none"> Press the NEW LINE key. Press the SIZE key. Press the UP ARROW or DOWN ARROW key to select the desired character size (1 ~ 7). Example: Size 2 Press the SIZE key again to determine the character size. 	<p style="text-align: center;">NEW LINE</p>  <p style="text-align: center;">SIZE</p> <p style="text-align: center;">↑ OR ↓</p>  <p style="text-align: center;">SIZE</p>

Step	Description	Keys and Display
5	<p>Text on the New Line</p> <ul style="list-style-type: none"> Enter in the desired text on the 2nd line. <p>Example: ((BEEF))</p> <ul style="list-style-type: none"> Press the ENTER key. 	
6	<p>Print</p> <ul style="list-style-type: none"> Press the PRINT key to confirm the entered text. 	

4.6 How to Insert Characters

Use the LEFT ARROW or RIGHT ARROW key to place the cursor on the character immediately after the desired location for character insertion. Then type the new character.

The displays shown below have both a character and a segment display. However, the AC-3000E has only a segment display.

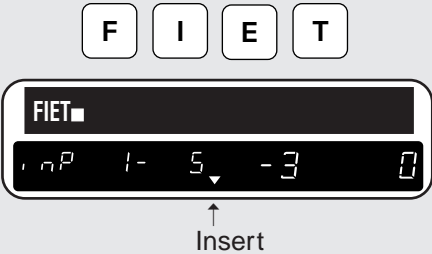
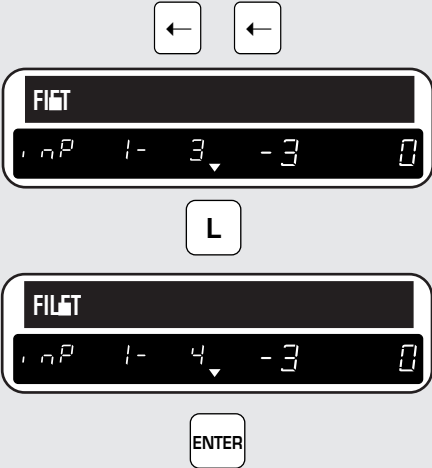
Step	Description	Keys and Display
1	<p>Mistaken Text</p> <ul style="list-style-type: none"> “FIET” instead of “FILET” was entered by mistake. 	
2	<p>Insert Mode</p> <ul style="list-style-type: none"> Make sure that the INSERT indicator is lit. <p>Note: If this indicator is not lit, press the INSERT key to turn on the INSERT indicator.</p>	
3	<p>Correction</p> <ul style="list-style-type: none"> Press the LEFT ARROW key twice to move the cursor two characters to the left. <p>Example: “L” between “I” and “E”</p> <ul style="list-style-type: none"> Type “L” followed by the ENTER key. 	

4.7 How to Change Characters

Use the LEFT ARROW or RIGHT ARROW key to place the cursor on the character to be changed. Then type the new character.

The displays shown below have both a character and a segment display. However, the AC-3000E has only a segment display.

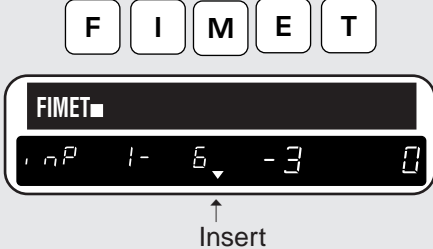
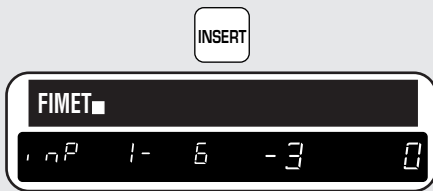
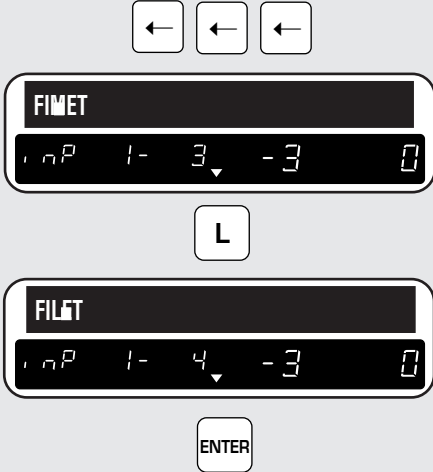
Step	Description	Keys and Display
1	Mistaken Text <ul style="list-style-type: none"> “FIMET” instead of “FILET” was entered by mistake. 	
2	Change Mode <ul style="list-style-type: none"> Press the INSERT key to turn off the INSERT indicator. <p><i>Note: Make sure that the INSERT indicator is not lit.</i></p>	
3	Correction <ul style="list-style-type: none"> Press the LEFT ARROW key three times to move the cursor three characters to the left. <p>Example: Change from “M” to “L”</p> <ul style="list-style-type: none"> Type “L” followed by the ENTER key. 	

4.8 How to Delete Characters

Use the LEFT ARROW or RIGHT ARROW key to place the cursor on the character to be deleted. Press the CHARACTER DELETE key to delete the selected characters.

The displays shown below have both a character and a segment display. However, the AC-3000E has only a segment display.

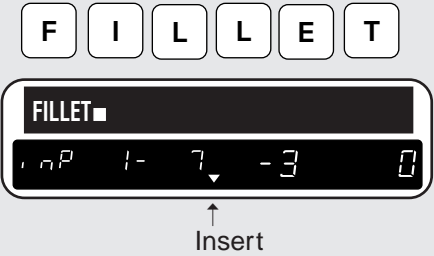
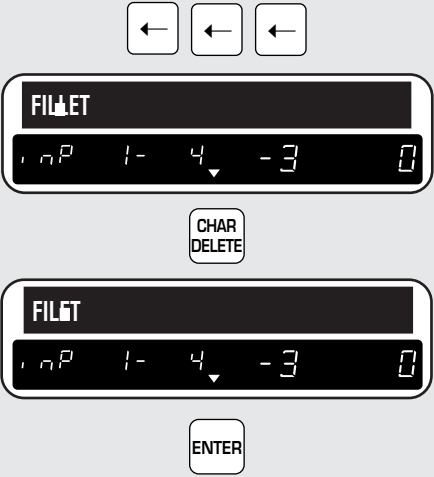
Step	Description	Keys and Display
1	Mistaken Text <ul style="list-style-type: none"> “FILLET” instead of “FILET” was entered by mistake. 	
2	Insert Mode <ul style="list-style-type: none"> Make sure that the INSERT indicator is lit. <p>Note: <i>If this indicator is not lit, press the INSERT key to turn on the INSERT indicator.</i></p>	
3	Correction <ul style="list-style-type: none"> Press the LEFT ARROW key three times to move the cursor three characters to the left. <p>Example: Delete “L”</p> <ul style="list-style-type: none"> Press the CHARACTER DELETE key followed by the ENTER key. 	

 **ISHIDA**

 **ISHIDA CO., LTD.**

44 SANNO-CHO, SHOGOIN, SAKYO-KU
KYOTO, 606 JAPAN
PHONE: (075) 771-4141
FACSIMILE: (075) 751-1634
TELEX: 05422065 SCALES J