

# Operating Manual



This manual is based on standard specifications. Therefore, application of this manual may depend on the country standards or customer specifications.

You can help to improve this manual by calling attention to errors and by recommending improvements. Please convey your comments to the nearest Ishida Company regional representative. **Thank you!**

**Copyright © 1997 by Ishida Co., Ltd. All Rights Reserved.**

No part of this manual may be reproduced in any form, by mimeograph or any other means, without written permission of the publisher.



## CAUTIONS FOR USE

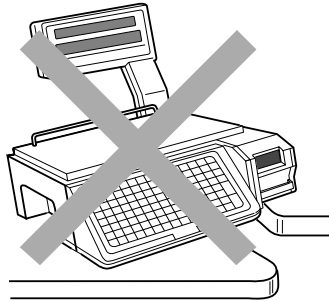

- Always operate the scale on a level surface.

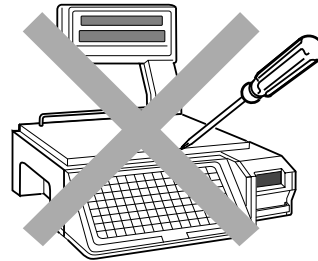

- Do not disassemble the scale.

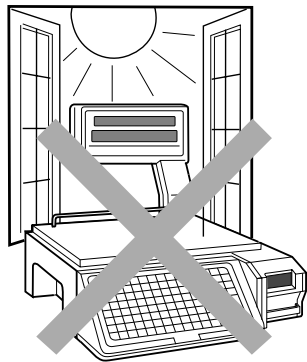

- Do not expose the scale to direct sunlight for long periods.

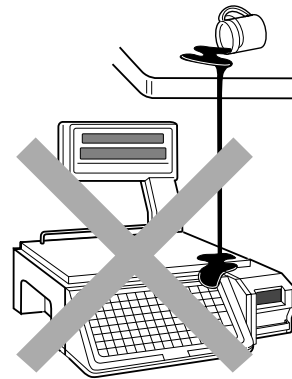

- Do not allow any liquids to come into contact with the scale or terminal.

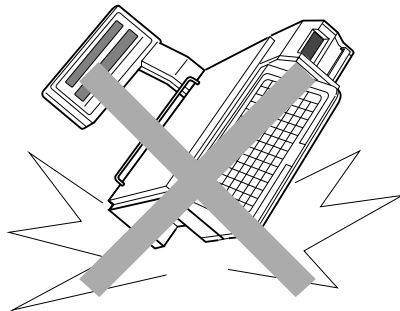

- Do not drop or apply a strong shock to the scale.

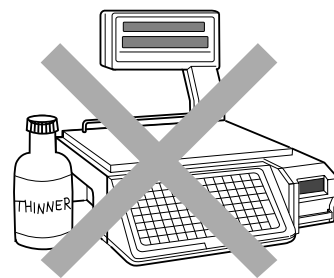

- When cleaning the scale, only use a soft dry cloth or a cloth wetted with a neutral cleanser. Never use thinner or other volatile liquids.

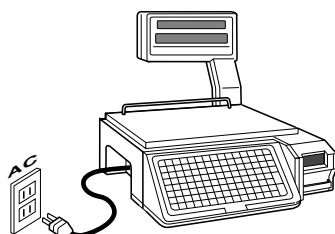

**Always operate the scale with the same rated AC power supply shown on the specification plate.**



## SAFETY CONSIDERATIONS

To ensure safe operation, the general safety considerations below must be followed.

### **Grounding**

This instrument is a Class 1 device which requires protective grounding for safe operation.

To avoid potential shock hazards, a protective grounding conductor for the instrument must be securely connected to the main grounding provision by qualified service personnel.

### **Do not remove covers or enclosures**

To avoid personal injury and shock, do not open or remove any covers or enclosures of the instrument unless specified in the manual.

### **Do not perform unspecified maintenance**

For your personal safety, do not perform any maintenance procedures which are not specified in the manual.

### **Disconnect power supply before servicing**

To ensure your personal safety, disconnect the power supply before servicing.

# CONTENTS

## Chapter 1: Overview

1.1 Appearance .....	2
1.2 Operator Display .....	2
1.3 Operation Keys .....	3
1.4 Loading Label/Receipt Roll .....	6
1.5 Pre-operation Inspection .....	8
1.6 Power On .....	9

## Chapter 2: Basic Operation for Label Application

2.1 Label Operation Flow .....	12
2.2 Counter Sale of Weighed Item .....	13
2.3 Counter Sale of Fixed-price Item .....	14
2.4 Prepack for Weighed Item .....	15
2.5 Prepack for Fixed-price Item .....	16
2.6 Label Batch Print .....	17
2.7 Pack Count Sub-total .....	18

## Chapter 3: Basic Operation for Receipt Application

3.1 Receipt Operation Flow .....	20
3.2 Weighted Item Sale .....	21
3.3 Fixed-price Item Sale .....	23
3.4 Payment Media .....	25
3.5 Subtotal Discount.....	26
3.6 Returned Item .....	27

## Chapter 4: On-demand Operation

4.1 Mark Down Functions.....	30
4.2 Unit Price Override .....	31
4.3 Voiding the Last Transaction.....	31
4.4 Changing from Weighed Item to Fixed-price Item .....	31
4.5 Fixed Weight Override .....	31
4.6 Date Override .....	32
4.7 Save .....	32
4.8 Logo Print.....	32

4.9 Store Name Print .....	33
4.10 Extra Text Print .....	33
4.11 POP Text Print .....	33
4.12 Coupon Text Print .....	34

## **Chapter 5: Subtraction**

5.1 Subtraction .....	36
-----------------------	----

## **Chapter 6: Troubleshooting**

6.1 Error Messages .....	40
6.2 How to Release Error Conditions .....	41
6.3 How to Replace Fuse .....	41
6.4 Other Problems .....	41

# CHAPTER 1

## OVERVIEW

### Contents

1.1	Appearance .....	2
1.2	Operator Display .....	2
1.3	Operation Keys .....	3
1.3.1	Operation Key Sheet .....	3
1.3.2	Basic Function Keys .....	4
1.3.3	Additional Function Keys .....	5
1.3.4	Preset Key Examples .....	5
1.4	Loading Label/Receipt Roll .....	6
1.4.1	AC-3000 .....	6
1.4.2	AC-3000E .....	7
1.5	Pre-operation Inspection .....	8
1.6	Power On .....	9

## 1.1 Appearance

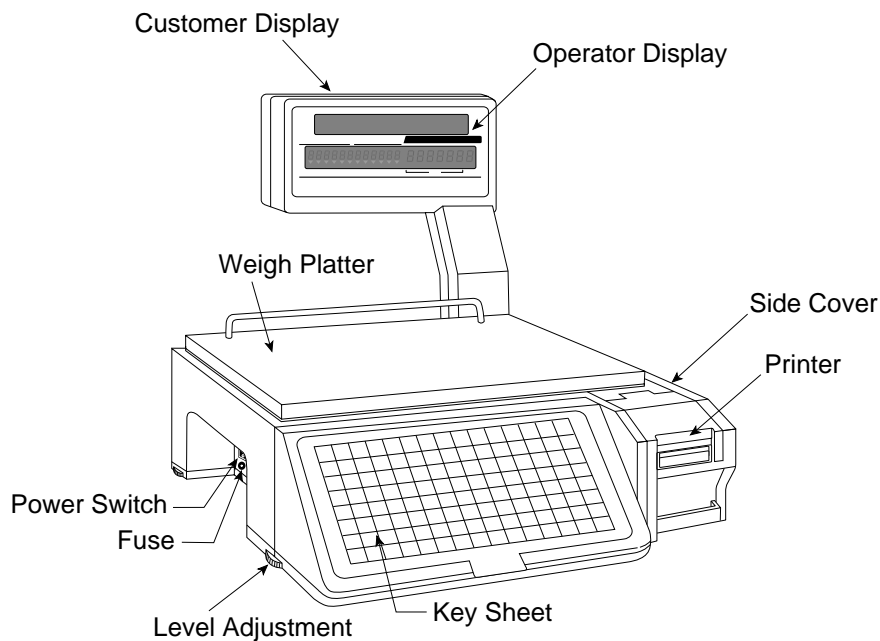

**Note:** The above illustration is of the AC-3000.

## 1.2 Operator Display

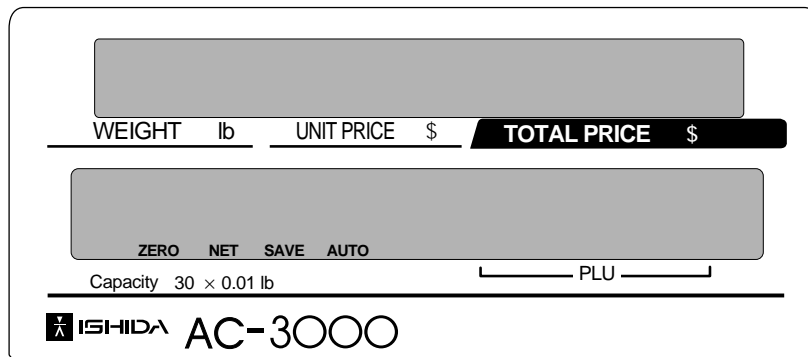

**AC-3000 Operator Display**

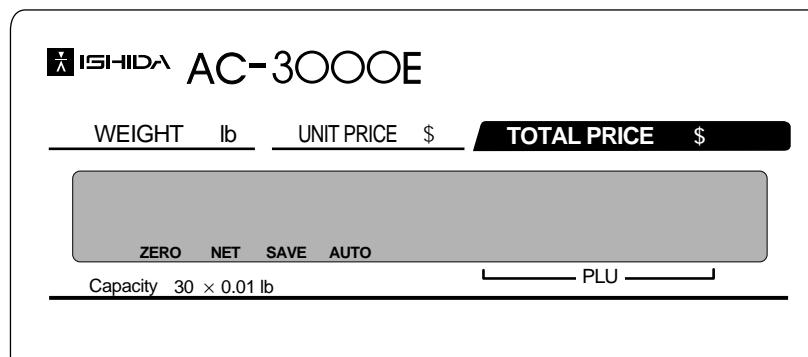

**AC-3000E Operator Display**

### Indicators

ZERO: Lights when weight value is true zero or temporary zero.

NET : Lights when a tare is used.

SAVE : Lights when the SAVE mode is used.

AUTO: Lights when the AUTOMATIC PRINT (prepack) mode is used.

## 1.3 Operation Keys

### 1.3.1 Operation Key Sheet

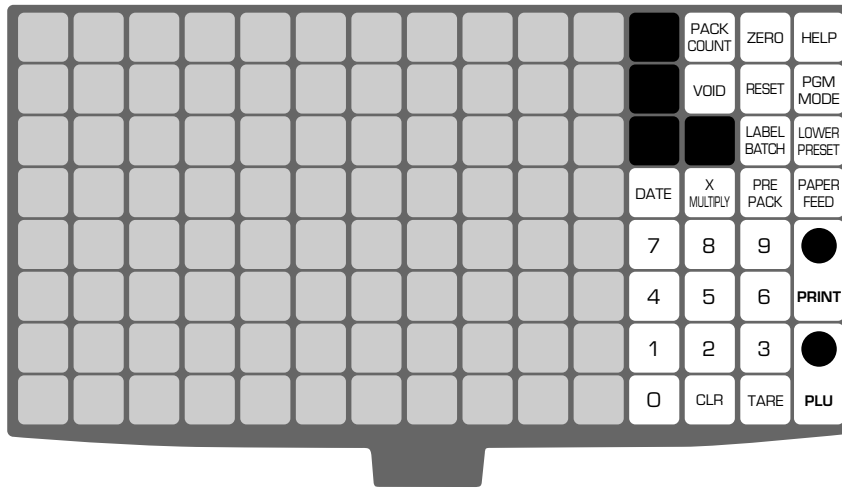

**Key Sheet for Label Application**

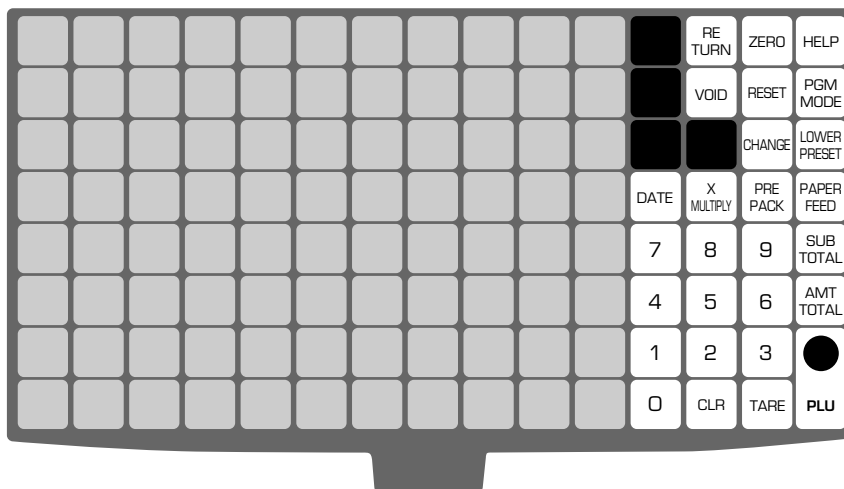

**Key Sheet for Receipt Application**

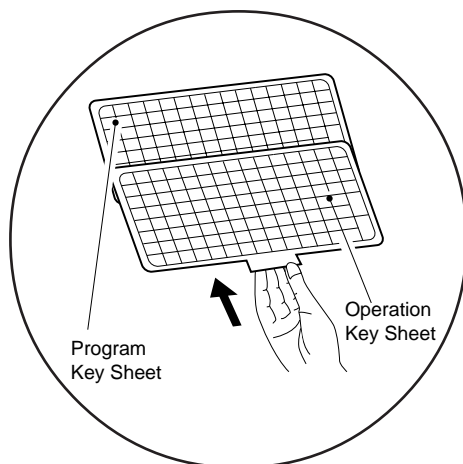

Insert the Operation Key Sheet over the Program Key Sheet.

 Preset Keys

 Additional Function Keys

Four of the following options can be preset by the dealer in accordance with the customer's request.

- DATE/TIME display
- STORE NAME number
- LOGO number
- EXTRA TEXT number
- POP TEXT number
- COUPON TEXT number
- FIXED PRICE
- DISCOUNT
- AMOUNT DISCOUNT
- PERCENTAGE DISCOUNT
- SAVE
- FIXED WEIGHT
- PRINT

---

## 1.3.2 Basic Function Keys

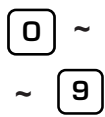

### NUMERIC ENTRY

Keys 0 through 9 are used to enter numeric data.



### TARE

Used to subtract the tare weight from the total weight on the weigh platter.



### CLEAR

Used to cancel incorrectly entered numeric data.  
Also used to stop printing labels.  
Also used to return to the operation mode.



### TEMPORARY DATE

Used to temporarily change the current date.



### LABEL BATCH (label application only)

Used to issue batches of labels.



### VOID

Used to cancel the previous item registration.



### LOWER PRESET

Used to access the second level of data programmed to the preset keys.



### ZERO ADJUSTMENT

Used to return the scale to zero when nothing is on the weigh platter.



### MULTIPLY

Used to multiply the entered quantity of fixed-price items.



### HELP (AC-3000 only)

Used to display an explanation (up to 32 letters) of each function.



### PACK COUNT SUB-TOTAL

(label application only)  
Used to issue a label that shows the number of labels (packs), total weight and amount which have been transacted since this key was last pressed.



### RESET

Used to forcibly exit a particular mode and return to the initial status of the operation mode.



### PAPER FEED

Used to advance labels/receipts to the correct printing position.



### RETURN (receipt application only)

Used to register the returned item.



### PLU SELECT

Used to access PLU data.  
Also used to display the tare weight.



### CHANGE (receipt application only)

Used when exchanging money. Also used to open the cash drawer.



### PREPACK

Used to switch between auto printing mode and manual printing mode.



### SUBTOTAL (receipt application only)

Used to subtotal the customer's purchases.



### PRINT (label application only)

Used to print labels/receipts.



### AMOUNT TOTAL

(receipt application only)  
Used to finalize the cash payment transaction, and also use to calculate the change due.



### PROGRAM MODE

Used to enter the subtraction mode after a 4-digit password has been entered.  
Also used to exit the subtraction mode.

---

### 1.3.3 Additional Function Keys

**DATE/TIME**

Used to display the current date and time for a few seconds.

**FIXED PRICE**

Used to temporarily change from weight item sales to fixed-price item sales. Also used to enter a new fixed price.

**STORE NAME**

Used to change the store name corresponding to the entered number.

**DISCOUNT**

Used to enter a special selling price.

**LOGO**

Used to access a logo message corresponding to the entered number after the PLU has been accessed.

**AMOUNT DISCOUNT**

Used to subtract the entered amount from the selling price.

**EXTRA TEXT**

Used to access an extra message corresponding to the entered number after the PLU has been accessed.

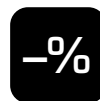
**PERCENTAGE DISCOUNT**

Used to subtract the entered percentage from the selling price.

**POP TEXT**

Used to access the POP text corresponding to the entered number after the PLU has been accessed.

**SAVE**

Used to save PLU data until the SAVE key is pressed again.

**COUPON TEXT**

Used to access a coupon message corresponding to the entered number after the PLU has been accessed.

**PRINT** (receipt application only)

Used to print labels. Also used to start batch printing.

**FIXED WEIGHT**

Used to temporarily change a fixed weight of the fixed price item.

### 1.3.4 Preset Key Examples

**CHECK** (receipt application only)

Used to finalize check payment transactions.

**TARE PRESET**

Used to access preset tare weight.

**CARD** (receipt application only)

Used to finalize credit card payment transactions.

**PERCENT DISCOUNT**

Used to access preset discount percentage.

**OPERATOR PRESET**

Used as a PRINT key by the designated operator.

**AMOUNT DISCOUNT**

Used to access preset discount amount.

**PLU PRESET**

Used to access PLU data (from among two levels).

---

## 1.4 Loading Label/Receipt Roll

### 1.4.1 AC-3000

1. Pull and remove the cassette from the main body.



When removing or replacing the cassette, securely grip the handle so as not to drop the cassette.

2. Load the new roll into the cassette and secure it with the roll clasp.

**Note:** Before installing the label roll, remove labels from the first 30 cm (12 inches) of backing paper.

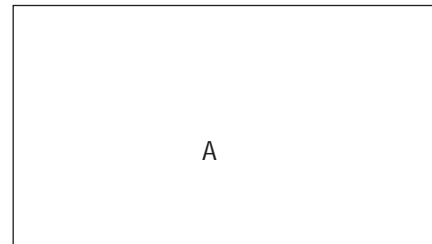
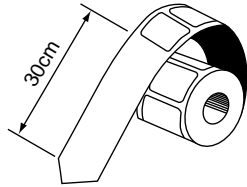

3. Thread the paper through positions shown in the diagram.

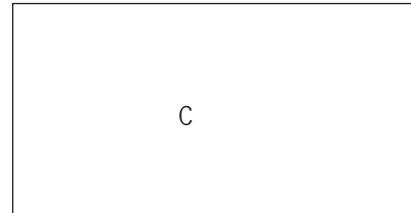
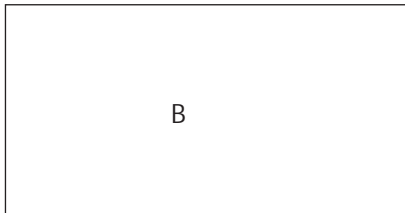

4. Wind the end of the backing paper around the winding sleeve, and secure it with the U-pin as shown in the diagram.



5. Replace the cassette into the main body by pushing it straight in until it is fully inserted.

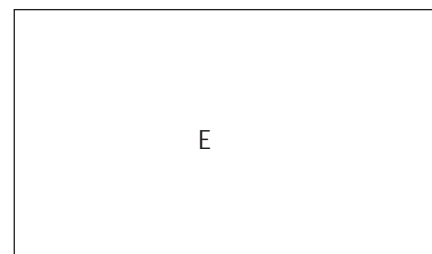

6. Press the PAPER FEED key to advance the label/receipt to the correct printing position.



## 1.4.2 AC-3000E

1. Make sure that the power is off.

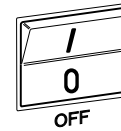

2. Open the side cover.

3. Pull the release lever to raise the printer head.

4. Load the new roll onto the holding shaft.

**Note:** Before installing the label roll, remove labels from the first 30 cm (12 inches) of backing paper.

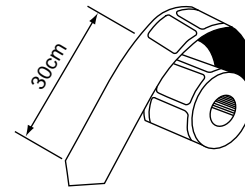

5. Thread the paper through positions as shown in the diagram.

**Check that the backing paper is:**

- threaded properly under the guide shaft.
- threaded properly through the label sensor.
- threaded properly over the peeling bar, making sure it passes through the groove.

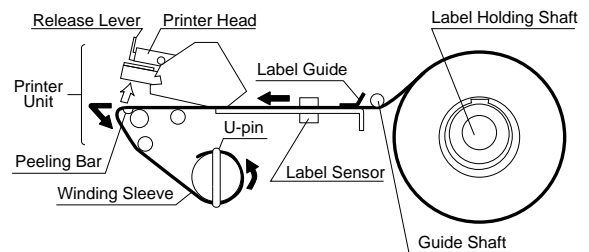
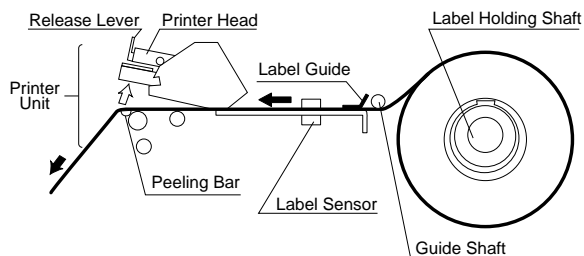

6. When the label needs to be wound up, wind the end of the backing paper around the winding sleeve and secure it with the U-pin as shown in the diagram.

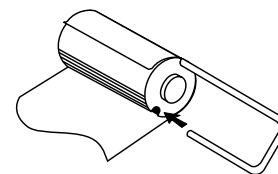

7. Push the printer head down until it locks securely.

8. Close the side cover.

9. Turn on the power and press the PAPER FEED key to advance the label/receipt to the correct printing position.



## 1.5 Pre-operation Inspection

In order to maintain optimum scale performance, perform the following inspection before starting daily operations.





Always turn off the power switch when performing this inspection.

1. Make sure that the power is off.

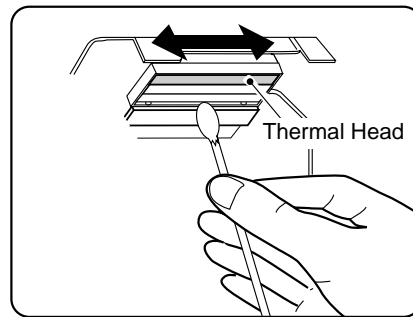

2. Check that the scale and the level device aperture are clean and free of foreign matter, label adhesive, etc. to make the scale level. If not, wipe any soiled areas with a dry cloth.
3. In order to maintain good printing quality, clean the thermal head at least once a week with a cotton swab dipped in cleaning fluid.





Do not use metal tools to clean the thermal head as they may damage the head surface.



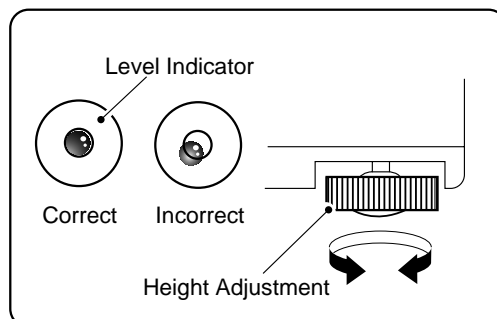

4. Adjust the scale to level by using the height adjustment feet.



5. Make sure the label/receipt amount is sufficient.

## 1.6 Power On

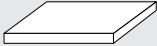
The displays shown below have both a character and a segment display. However, the AC-3000E has only a segment display.

<b>1</b> Make sure that the power cord is plugged into the AC outlet.	
<b>2</b> Turn on the power switch.	
<b>3</b> Make sure that nothing is on the weigh platter.	
<b>4</b> Check that the ZERO indicator is lit.  <i>Note: If the ZERO indicator is not lit, press the ZERO key.</i>	 <p>Initial display</p>

# CHAPTER 2

## BASIC OPERATION FOR LABEL APPLICATION



### Contents

2.1	Label Operation Flow .....	12
2.1.1	Start-up Operations .....	12
2.1.2	Operation Flow .....	12
2.2	Counter Sale of Weighed Item .....	13
2.3	Counter Sale of Fixed-price Item ..	14
2.4	Prepack for Weighed Item .....	15
2.5	Prepack for Fixed-price Item .....	16
2.6	Label Batch Print.....	17
2.7	Pack Count Sub-total .....	18

## 2.1 Label Operation Flow

### 2.1.1 Start-up Operations

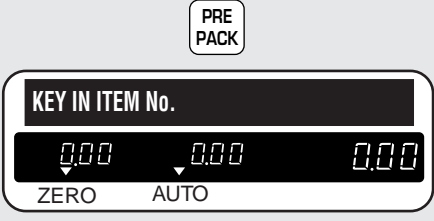
The displays shown below have both a character and a segment display. However, the AC-3000E has only a segment display.





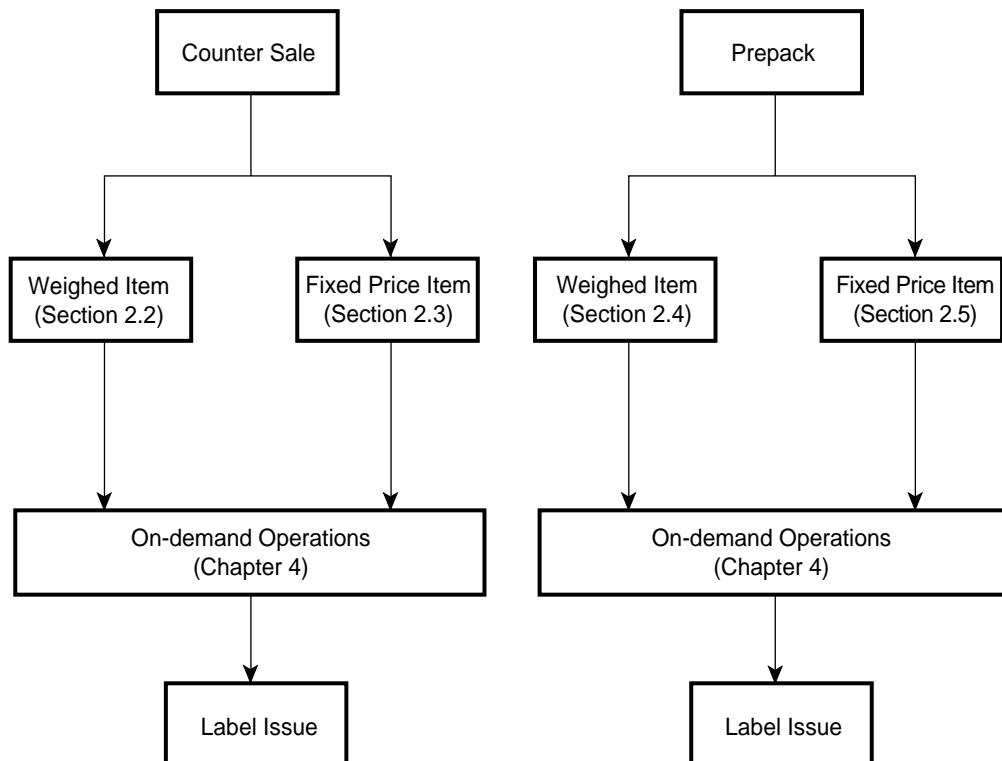

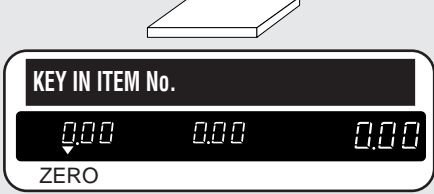

<p><b>(1) Label issuing mode</b></p> <ul style="list-style-type: none"> <li>Check that the ZERO indicator is lit.</li> </ul> <p><b>Note:</b> If the ZERO indicator is not lit, press the ZERO key to turn on the indicator.</p> <ul style="list-style-type: none"> <li>If automatic printing is desired, press the PREPACK key to turn on the AUTO indicator, if it is not lit.</li> </ul>	
<p><b>(2) Receipt issuing mode</b></p> <ul style="list-style-type: none"> <li>Check that the ZERO indicator is lit.</li> </ul> <p><b>Note:</b> If the ZERO indicator is not lit, press the ZERO key to turn on the indicator.</p> <ul style="list-style-type: none"> <li>Check that the AUTO indicator is not lit.</li> </ul> <p><b>Note:</b> If the AUTO indicator is lit, press the PREPACK key to turn off the indicator.</p>	

### 2.1.2 Operation Flow





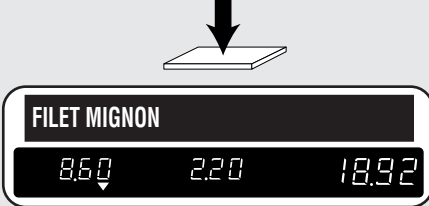





## 2.2 Counter Sale of Weighed Item

The displays shown below have both a character and a segment display. However, the AC-3000E has only a segment display.

<p><b>1 Confirm that the initial display appears on the screen.</b></p> <ul style="list-style-type: none"> <li>• Check that nothing is on the weigh platter.</li> <li>• Check that the ZERO indicator is lit.</li> </ul> <p><b>Note:</b> If the ZERO indicator is not lit, press the ZERO key to turn on the indicator.</p> <ul style="list-style-type: none"> <li>• Check that the AUTO indicator is not lit.</li> </ul> <p><b>Note:</b> If the AUTO indicator is lit, press the PREPACK key to turn off the indicator.</p>	
<p><b>2 Enter the PLU.</b></p> <ul style="list-style-type: none"> <li>▪ <b>Entering PLU number</b> <ul style="list-style-type: none"> <li>• Enter the PLU number and press the PLU key.</li> </ul> <p><b>Example:</b> PLU no. = 350</p> </li> <li>▪ <b>Pressing PLU (preset) key</b> <ul style="list-style-type: none"> <li>• Press the preset key in which the PLU number is set.</li> </ul> <p><b>Note:</b> When accessing the lower preset PLU number, press the LOWER PRESET key prior to pressing the preset key.</p> </li> </ul>	 <p><b>Example:</b> When accessing PLU10</p>  <p><b>Example:</b> When accessing PLU90</p> 
<p><b>3 Subtract the tare.</b></p> <ul style="list-style-type: none"> <li>▪ <b>Weighing tare</b> <ul style="list-style-type: none"> <li>• Place the tare on the weigh platter.</li> <li>• Press the TARE key.</li> </ul> </li> <li>▪ <b>Entering tare weight</b> <ul style="list-style-type: none"> <li>• Enter the tare weight and press the TARE key.</li> </ul> <p><b>Example:</b> Tare weight = 0.08 lb.</p> </li> <li>▪ <b>Pressing tare look-up key</b> <ul style="list-style-type: none"> <li>• Press the Tare Look-Up (preset) key.</li> </ul> <p><b>Example:</b> Tare look up #1 = 0.12 lb.</p> </li> </ul>	 <p><b>Example:</b> Entering tare weight</p>  <p><b>Example:</b> Pressing tare look-up key</p> 
<p><b>4 Weigh the item.</b></p> <ul style="list-style-type: none"> <li>• Place the item on the weigh platter.</li> </ul> <p><b>Example:</b> Net weight = 8.60 lb. Unit price = \$2.20/lb.</p>	
<p><b>5 Issue the label.</b></p> <ul style="list-style-type: none"> <li>▪ <b>When the operator system is not used,</b> <ul style="list-style-type: none"> <li>• Press the PRINT key.</li> </ul> </li> <li>▪ <b>When the operator system is used,</b> <ul style="list-style-type: none"> <li>• Press the OPERATOR (preset) key.</li> </ul> </li> </ul>	 <p>-----</p> 





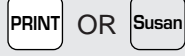



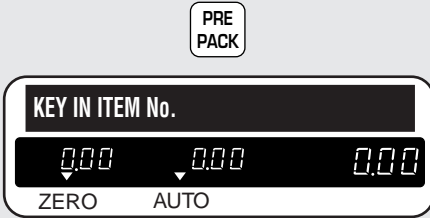

## 2.3 Counter Sale of Fixed-price Item

The displays shown below have both a character and a segment display. However, the AC-3000E has only a segment display.

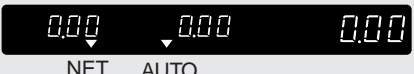
<p><b>1 Confirm that the initial display appears on the screen.</b></p> <ul style="list-style-type: none"> <li>• Check that nothing is on the weigh platter.</li> <li>• Check that the ZERO indicator is lit.</li> </ul> <p><b>Note:</b> If the ZERO indicator is not lit, press the ZERO key to turn on the indicator.</p> <ul style="list-style-type: none"> <li>• Check that the AUTO indicator is not lit.</li> </ul> <p><b>Note:</b> If the AUTO indicator is lit, press the PREPACK key to turn off the indicator.</p>	 
<p><b>2 Enter the PLU.</b></p> <ul style="list-style-type: none"> <li>▪ <b>Entering PLU number</b> <ul style="list-style-type: none"> <li>• Enter the PLU number and press the PLU key.</li> </ul> <p><b>Example:</b> PLU no. = 450 Fixed price = \$2.20</p> </li> <li>▪ <b>Pressing PLU (preset) key</b> <ul style="list-style-type: none"> <li>• Press the preset key in which the PLU number is set.</li> </ul> <p><b>Note:</b> When accessing the lower preset PLU number, press the LOWER PRESET key prior to pressing the preset key.</p> </li> </ul>	  <p><b>Example:</b> When accessing PLU15</p>  <p><b>Example:</b> When accessing PLU95</p> 
<p><b>3 Multiply the quantity, if any.</b></p> <ul style="list-style-type: none"> <li>• When selling more than one of the same item, enter the quantity and press the MULTIPLY key.</li> <li>• Otherwise, go to the next step.</li> </ul>	 
<p><b>4 Issue the label.</b></p> <ul style="list-style-type: none"> <li>▪ <b>Multiple labels</b> <ul style="list-style-type: none"> <li>• Enter the number of labels, and press the PRINT key.</li> </ul> </li> <li>▪ <b>One label</b> <ul style="list-style-type: none"> <li>• Press the PRINT key when the operator system is not used.</li> </ul> <p>OR</p> <ul style="list-style-type: none"> <li>• Press the OPERATOR (preset) key when the operator system is used.</li> </ul> </li> </ul> <p><b>Note:</b> Press the CLEAR key once to temporarily stop printing. To continue printing, press the PRINT key again.</p>	<p><b>Example:</b> Ten labels</p>  <p><b>Example:</b> One label</p> 

## 2.4 Prepack for Weighed Item

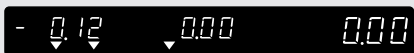
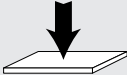
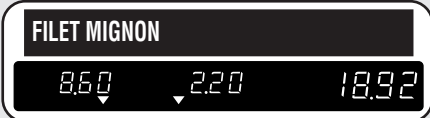
The displays shown below have both a character and a segment display. However, the AC-3000E has only a segment display.

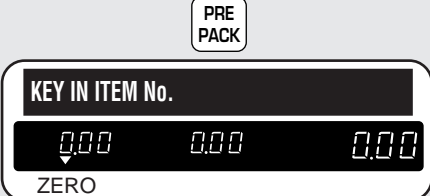
<p><b>1 Enter the prepack mode.</b></p> <ul style="list-style-type: none"> <li>• Check that nothing is on the weigh platter.</li> <li>• Check that the ZERO indicator is lit.</li> </ul> <p><b>Note:</b> If the ZERO indicator is not lit, press the ZERO key to turn on the indicator.</p> <ul style="list-style-type: none"> <li>• Press the PREPACK key to turn on the AUTO indicator, if it is not lit.</li> </ul>	
<p><b>2 Enter the PLU.</b></p> <ul style="list-style-type: none"> <li>▪ <b>Entering PLU number</b> <ul style="list-style-type: none"> <li>• Enter the PLU number and press the PLU key.</li> </ul> <p><b>Example:</b> PLU no. = 350</p> </li> <li>▪ <b>Pressing PLU (preset) key</b> <ul style="list-style-type: none"> <li>• Press the preset key in which the PLU number is set.</li> </ul> <p><b>Note:</b> When accessing the lower preset PLU number, press the LOWER PRESET key prior to pressing the preset key.</p> </li> </ul>	 <p><b>Example:</b> When accessing PLU10</p>  <p><b>Example:</b> When accessing PLU90</p> 
<p><b>3 Subtract the tare.</b></p> <ul style="list-style-type: none"> <li>▪ <b>Weighing tare</b> <ul style="list-style-type: none"> <li>• Place the tare on the weigh platter.</li> <li>• Press the TARE key.</li> </ul> </li> <li>▪ <b>Entering tare weight</b> <ul style="list-style-type: none"> <li>• Enter the tare weight and press the TARE key.</li> </ul> <p><b>Example:</b> Tare weight = 0.08 lb.</p> </li> <li>▪ <b>Pressing tare look-up key</b> <ul style="list-style-type: none"> <li>• Press the Tare Look-Up (preset) key.</li> </ul> <p><b>Example:</b> Tare look up #1 = 0.12 lb.</p> </li> </ul> <p><b>Weigh the item.</b></p>	     
<ul style="list-style-type: none"> <li>• Place the item on the weigh platter.</li> </ul> <p><b>Example:</b> Net weight = 8.60 lb. Unit price = \$2.20/lb.</p> <ul style="list-style-type: none"> <li>• The label is automatically printed.</li> <li>• Repeat this step until all the items of the same PLU are weighed.</li> </ul>	  
<p><b>Exit the prepack mode.</b></p> <ul style="list-style-type: none"> <li>• Press the PREPACK key.</li> <li>• The AUTO indicator will turn off.</li> </ul>	

## 2.5 Prepack for Fixed-price Item



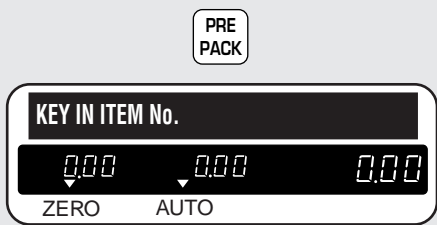
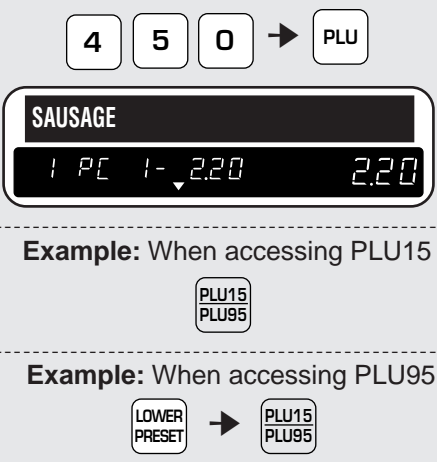
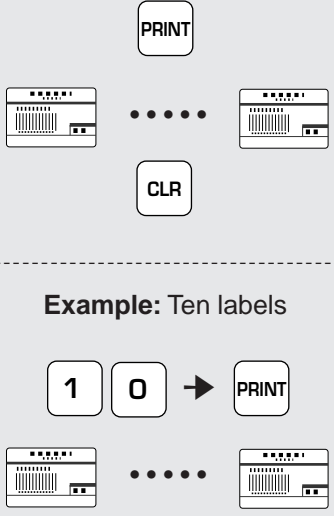
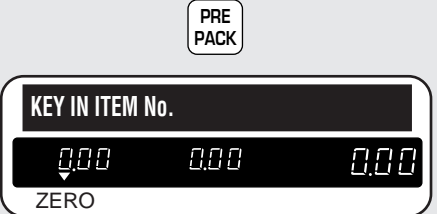

The displays shown below have both a character and a segment display. However, the AC-3000E has only a segment display.

<p><b>1 Enter the prepack mode.</b></p> <ul style="list-style-type: none"> <li>• Check that nothing is on the weigh platter.</li> <li>• Check that the ZERO indicator is lit.</li> </ul> <p><b>Note:</b> If the ZERO indicator is not lit, press the ZERO key to turn on the indicator.</p> <ul style="list-style-type: none"> <li>• Press the PREPACK key to turn on the AUTO indicator, if it is not lit.</li> </ul>	
<p><b>2 Enter the PLU.</b></p> <ul style="list-style-type: none"> <li>▪ <b>Entering PLU number</b> <ul style="list-style-type: none"> <li>• Enter the PLU number and press the PLU key.</li> </ul> <p><b>Example:</b>     PLU no. = 450                   Fixed price = \$2.20</p> </li> <li>▪ <b>Pressing PLU (preset) key</b> <ul style="list-style-type: none"> <li>• Press the preset key in which the PLU number is set.</li> </ul> <p><b>Note:</b> When accessing the lower preset PLU number, press the LOWER PRESET key prior to pressing the preset key.</p> </li> </ul>	 <p><b>Example:</b> When accessing PLU15</p> <p><b>Example:</b> When accessing PLU95</p>
<p><b>3 Print labels.</b></p> <ul style="list-style-type: none"> <li>▪ <b>Continuous issue</b> <ul style="list-style-type: none"> <li>• Press the PRINT key to continuously issue labels.</li> <li>• Press the CLEAR key to stop printing.</li> </ul> </li> <li>▪ <b>Specified number of labels</b> <ul style="list-style-type: none"> <li>• Enter the number of labels, and press the PRINT key.</li> </ul> <p><b>Note:</b> Press the CLEAR key once to temporarily stop printing. To continue printing, press the PRINT key again.</p> </li> </ul>	 <p><b>Example:</b> Ten labels</p>
<p><b>4 Exit the prepack mode.</b></p> <ul style="list-style-type: none"> <li>• Press the PREPACK key.</li> <li>• The AUTO indicator will turn off.</li> </ul>	

## 2.6 Label Batch Print

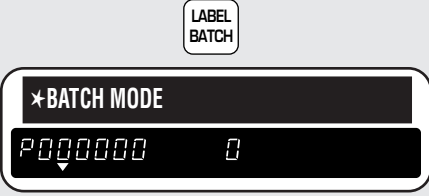
This function presets the number of fixed-price labels (max. 20 PLUs) to be printed. This function is only available for fixed-price items.

The displays shown below have both a character and a segment display. However, the AC-3000E has only a segment display.

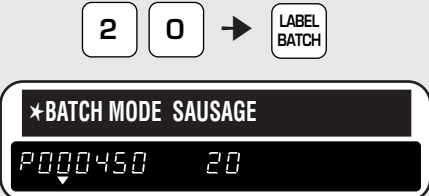
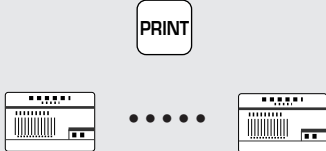
<p><b>1 Enter the label batch print mode.</b></p> <ul style="list-style-type: none"> <li>Press the LABEL BATCH key to enter the label batch print mode.</li> </ul>	
<p><b>2 Enter the PLU.</b></p> <ul style="list-style-type: none"> <li><b>Entering PLU number</b> <ul style="list-style-type: none"> <li>Enter the PLU number and press the PLU key. <b>Example:</b> PLU no. = 450</li> </ul> </li> <li><b>Pressing PLU (preset) key</b> <ul style="list-style-type: none"> <li>Press the preset key in which the PLU number is set. <b>Note:</b> When accessing the lower preset PLU number, press the LOWER PRESET key prior to pressing the preset key.</li> </ul> </li> </ul>	 <p><b>Example:</b> When accessing PLU15</p>  <p><b>Example:</b> When accessing PLU95</p> 
<p><b>3 Enter the desired number of labels.</b></p> <ul style="list-style-type: none"> <li>Enter the number of labels to be issued. (Max. 999)</li> <li>Press the LABEL BATCH key.</li> </ul>	<p><b>Example:</b> Twenty labels</p> 
<p><b>4 Enter any other PLUs, if necessary.</b></p> <ul style="list-style-type: none"> <li>Repeat steps 2 and 3 when labels for any other PLUs are needed. A maximum of 20 PLUs can be entered.</li> </ul>	
<p><b>5 Print labels.</b></p> <ul style="list-style-type: none"> <li>Press the PRINT key.</li> </ul> <p><b>Note:</b> Press the CLEAR key to temporarily stop printing. To continue printing, press the PRINT key again. To cancel batch, press CLEAR key again.</p>	

## 2.7 Pack Count Sub-total

This function is used to print the pre-packing information label, including the total quantity, total weight and total amount which have been issued since the last time the PACK COUNT key was pressed.

The displays shown below have both a character and a segment display. However, the AC-3000E has only a segment display.

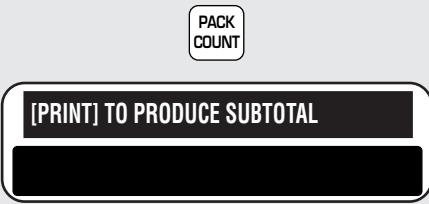
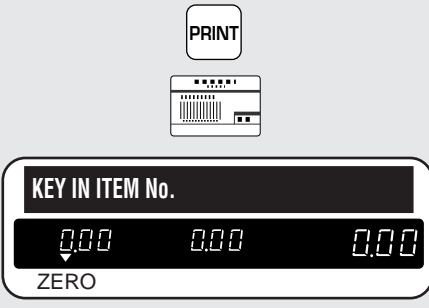
<p><b>1 Enter the pack count sub-total mode.</b></p> <ul style="list-style-type: none"><li>• Press the PACK COUNT key.</li></ul>	 <p>The image shows a scale display with a 'PACK COUNT' button at the top. Below it, a message box displays '[PRINT] TO PRODUCE SUBTOTAL'.</p>
<p><b>2 Print the pack count sub-total.</b></p> <ul style="list-style-type: none"><li>• Press the PRINT key.</li><li>• The scale returns to the initial display after issuing pack count sub-total label.</li></ul>	 <p>The image shows a scale display with a 'PRINT' button at the top. Below it is a barcode. The main display area shows 'KEY IN ITEM No.' followed by three '0.00' values and the word 'ZERO' at the bottom.</p>

# CHAPTER 3



## BASIC OPERATION FOR RECEIPT APPLICATION

### Contents

3.1	Receipt Operation Flow .....	20
3.1.1	Start-up Operations .....	20
3.1.2	Operation Flow .....	20
3.2	Weighed Item Sale .....	21
3.3	Fixed-price Item Sale .....	23
3.4	Payment Method .....	25
3.4.1	Cash Payment .....	25
3.4.2	Check Payment .....	25
3.4.3	Card Payment .....	25
3.4.4	Mixed Payments .....	25
3.5	Subtotal Discount .....	26
3.5.1	Subtotal Amount Discount .....	26
3.5.2	Subtotal Percent Discount .....	26
3.5.3	Subtotal Special Price .....	26
3.6	Returned Item .....	27

## 3.1 Receipt Operation Flow

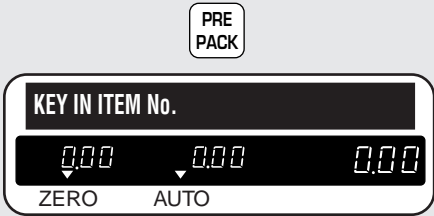
### 3.1.1 Start-up Operations





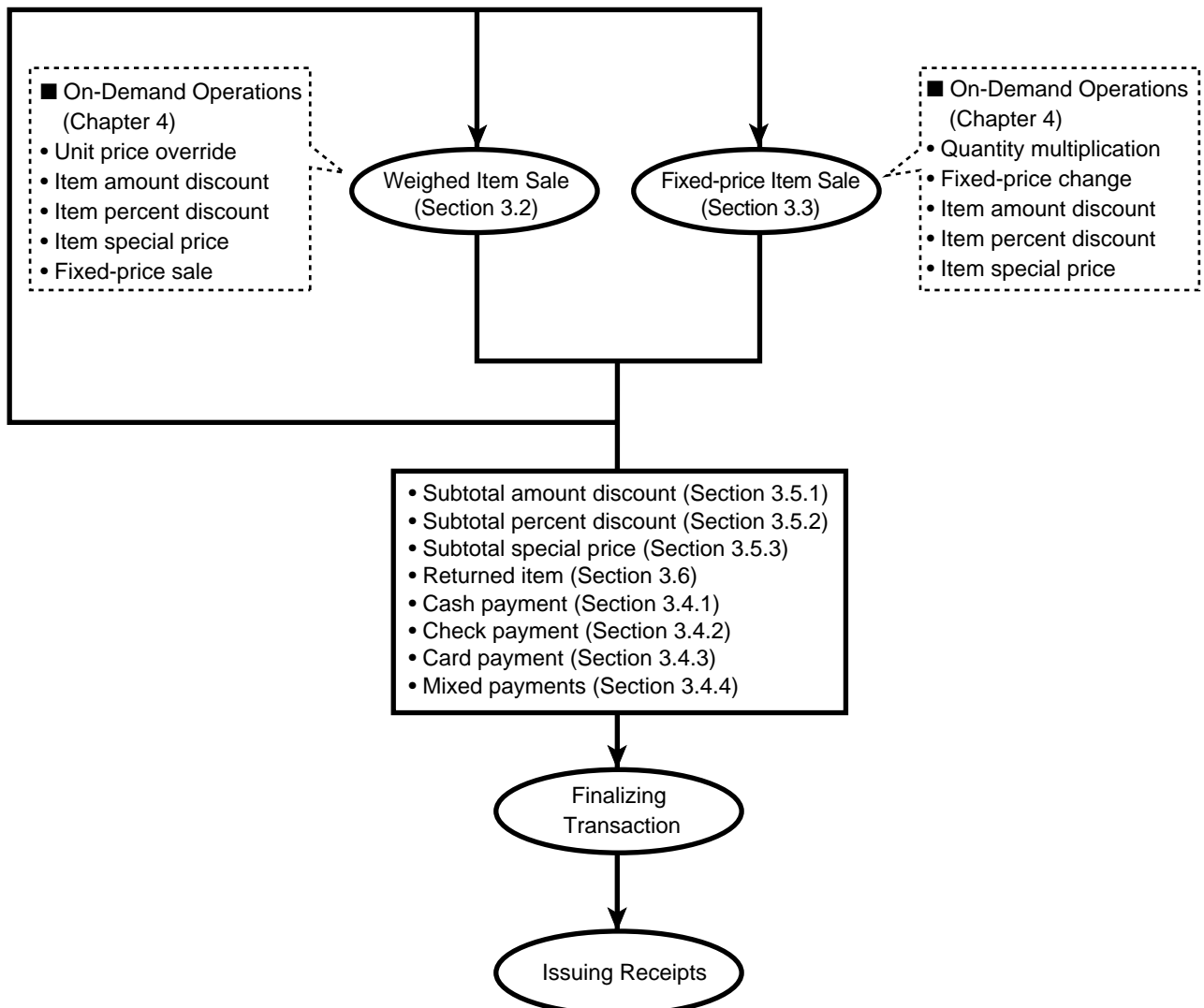

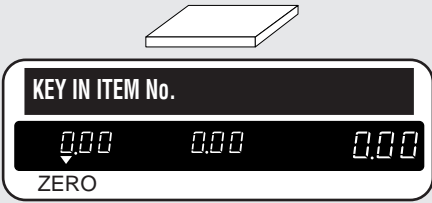

<p><b>(1) Label issuing mode</b></p> <ul style="list-style-type: none"> <li>• Check that the ZERO indicator is lit.</li> </ul> <p><b>Note:</b> If the ZERO indicator is not lit, press the ZERO key to turn on the indicator.</p> <ul style="list-style-type: none"> <li>• Press the PREPACK key to turn on the AUTO indicator, if it is not lit.</li> </ul>	
<p><b>(2) Receipt issuing mode</b></p> <ul style="list-style-type: none"> <li>• Check that the ZERO indicator is lit.</li> </ul> <p><b>Note:</b> If the ZERO indicator is not lit, press the ZERO key to turn on the indicator.</p> <ul style="list-style-type: none"> <li>• Check that the AUTO indicator is not lit.</li> </ul> <p><b>Note:</b> If the AUTO indicator is lit, press the PREPACK key to turn off the indicator.</p>	

### 3.1.2 Operation Flow

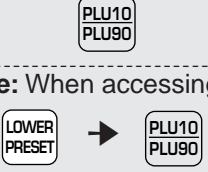

## 3.2 Weighed Item Sale

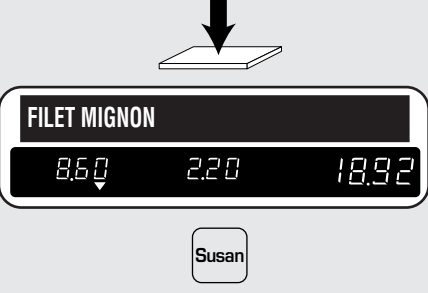
The displays shown below have both a character and a segment display. However, the AC-3000E has only a segment display.

<p><b>1 Confirm that the initial display appears on the screen.</b></p> <ul style="list-style-type: none"> <li>• Check that nothing is on the weigh platter.</li> <li>• Check that the ZERO indicator is lit.</li> </ul> <p><b>Note:</b> If the ZERO indicator is not lit, press the ZERO key to turn on the indicator.</p> <ul style="list-style-type: none"> <li>• Check that the AUTO indicator is not lit.</li> </ul> <p><b>Note:</b> If the AUTO indicator is lit, press the PREPACK key to turn off the indicator.</p>	
<p><b>2 Enter the PLU.</b></p> <ul style="list-style-type: none"> <li>▪ <b>Entering PLU number</b> <ul style="list-style-type: none"> <li>• Enter the PLU number and press the PLU key.</li> </ul> <p><b>Example:</b> PLU no. = 3 5 0</p> </li> <li>▪ <b>Pressing PLU (preset) key</b> <ul style="list-style-type: none"> <li>• Press the preset key in which the PLU number is set.</li> </ul> <p><b>Note:</b> When accessing the lower preset PLU number, press the LOWER PRESET key prior to pressing the preset key.</p> </li> </ul>	 <p><b>Example:</b> When accessing PLU10</p>  <p><b>Example:</b> When accessing PLU90</p>
<p><b>3 Subtract the tare.</b></p> <ul style="list-style-type: none"> <li>▪ <b>Weighing tare</b> <ul style="list-style-type: none"> <li>• Place the tare on the weigh platter.</li> <li>• Press the TARE key.</li> </ul> </li> <li>▪ <b>Entering tare weight</b> <ul style="list-style-type: none"> <li>• Enter the tare weight and press the TARE key.</li> </ul> <p><b>Example:</b> Tare weight = 0.08 lb.</p> </li> <li>▪ <b>Pressing tare look-up key</b> <ul style="list-style-type: none"> <li>• Press the Tare Look-Up (preset) key.</li> </ul> <p><b>Example:</b> Tare look up #1 = 0.12 lb.</p> </li> </ul>	  
<p><b>4 Weigh the item.</b></p> <ul style="list-style-type: none"> <li>• Place the item on the weigh platter.</li> </ul> <p><b>Example:</b> Net weight = 8.60 lb. Unit price = \$2.20/lb.</p> <ul style="list-style-type: none"> <li>• Press the OPERATOR (preset) key in which the operator's number is set.</li> </ul>	 

## 5 Repeat the item sale, if any.

- Repeat steps 2, 3 and 4 for any other items.

**Example:** PLU no. = 1 5 0  
Net weight = 2.50 lb.  
Unit price = \$1.50/lb.

1 5 0 → PLU

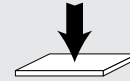

LAMB CHOPS		
2.50	1.50	3.75

Susan

*ADD	OPE:01	TOTAL 22.67
2PC9	0.00	22.67

## 6 Issue the receipt.

- Enter the amount tendered by the customer and press the AMOUNT TOTAL key. Then the change due will be calculated and the receipt will be issued.

**Example:** The customer pays \$30.00.



3 0 0 0 → AMT TOTAL

*AMOUNT	PCS02	CHANGE 7.33
2PC9	0.00	7.33

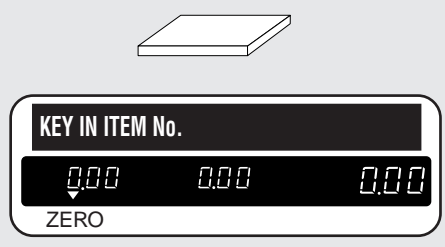
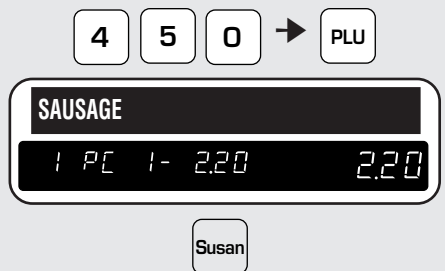
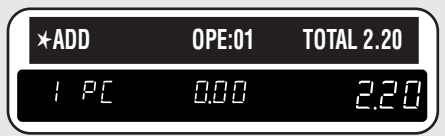

### 3.3 Fixed-price Item Sale

The displays shown below have both a character and a segment display. However, the AC-3000E has only a segment display.

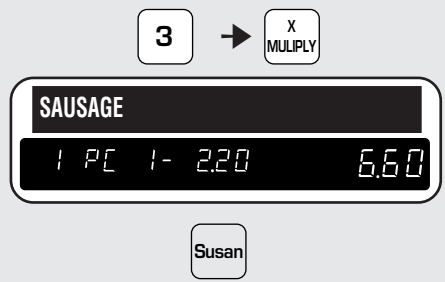
<p><b>1 Confirm that the initial display appears on the screen.</b></p> <ul style="list-style-type: none"> <li>• Check that nothing is on the weigh platter.</li> <li>• Check that the ZERO indicator is lit.</li> </ul> <p><b>Note:</b> If the ZERO indicator is not lit, press the ZERO key to turn on the indicator.</p> <ul style="list-style-type: none"> <li>• Check that the AUTO indicator is not lit.</li> </ul> <p><b>Note:</b> If the AUTO indicator is lit, press the PREPACK key to turn off the indicator.</p>	
<p><b>2 Enter the PLU.</b></p> <ul style="list-style-type: none"> <li>▪ <b>Entering PLU number</b> <ul style="list-style-type: none"> <li>• Enter the PLU number and press the PLU key.</li> </ul> <p><b>Example:</b> PLU no. = 4 5 0 Fixed price = \$2.20</p> </li> <li>• Press the OPERATOR (preset) key to register a single item.</li> </ul> <p><b>Note:</b> The OPERATOR key depression is not necessary when using the multiply function (selling more than one of the same item).</p> <ul style="list-style-type: none"> <li>▪ <b>Pressing PLU (preset) key</b> <ul style="list-style-type: none"> <li>• Press the preset key in which the PLU number is set.</li> <li>• Press the OPERATOR (preset) key to register a single item.</li> </ul> </li> </ul> <p><b>Note 1.</b> The OPERATOR key depression is not necessary when using the multiply function (selling more than one of the same item).</p> <p><b>2.</b> When accessing the lower preset PLU number, press the LOWER PRESET key prior to pressing the preset key.</p>	  <p><b>Example:</b> When accessing PLU15</p>  <p><b>Example:</b> When accessing PLU95</p> 
<p><b>3 Multiply the quantity, if any.</b></p> <ul style="list-style-type: none"> <li>• When selling more than one of the same item, enter the quantity and press the MULTIPLY key and then press the OPERATOR (preset) key to register the multiple items.</li> <li>• Otherwise, go to the next step.</li> </ul>	

#### 4 Repeat the item sale, if any.

- Repeat steps 2 and 3 for any other items.

**Example:** PLU no. = 4 8 0  
Fixed price = \$0.98

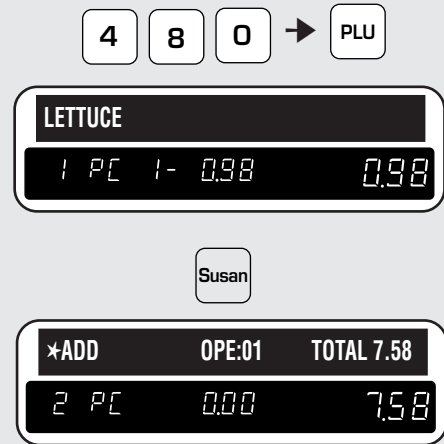

#### 5 Issue the receipt.

- Enter the amount tendered by the customer and press the AMOUNT TOTAL key. Then the change due will be calculated and the receipt will be issued.

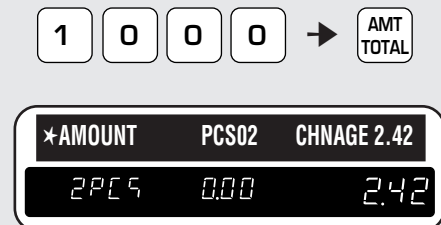

**Example:** The customer pays \$10.00.



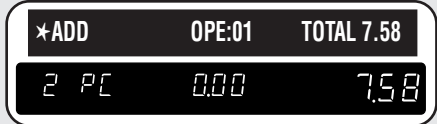

## 3.4 Payment Method

### 3.4.1 Cash Payment



The displays shown below have both a character and a segment display. However, the AC-3000E has only a segment display.

<p><b>1 Finalize the transaction.</b></p> <ul style="list-style-type: none"> <li>Enter the amount tendered by the customer if any.</li> <li>Press the AMOUNT TOTAL key, and the receipt will be issued.</li> </ul> <p><i>Note: At this time the change due will be calculated if the tendered amount has been entered.</i></p>	 <p>★ADD    OPE:01    TOTAL 7.58 2 PC    0.00    7.58</p> <p><b>Example:</b> The customer pays \$10.00.</p> <p>1 0 0 0 → AMT TOTAL </p>  <p>★AMOUNT    PCS02    CHANGE 2.42 2 PC    0.00    2.42</p>
--	---

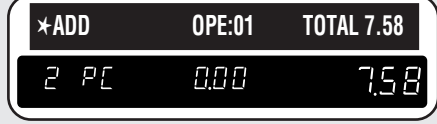

### 3.4.2 Check Payment

<p><b>1 Finalize the transaction.</b></p> <ul style="list-style-type: none"> <li>Press the CHECK key, and the receipt will be issued.</li> </ul>	 <p>★ADD    OPE:01    TOTAL 7.58 2 PC    0.00    7.58</p> <p>CHECK </p>
--	---

### 3.4.3 Card Payment

<p><b>1 Finalize the transaction.</b></p> <ul style="list-style-type: none"> <li>Press the CARD key, and the receipt will be issued.</li> </ul>	 <p>★ADD    OPE:01    TOTAL 7.58 2 PC    0.00    7.58</p> <p>CARD </p>
---	---

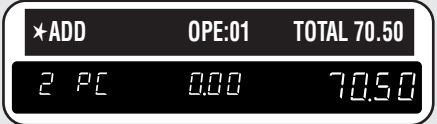
### 3.4.4 Mixed Payments

<p><b>1 Enter first payment.</b></p> <ul style="list-style-type: none"> <li>Enter the first payment amount tendered by the customer.</li> <li>Press the key corresponding to the payment media.</li> </ul>	 <p>★ADD    OPE:01    TOTAL 70.50 2 PC    0.00    70.50</p> <p><b>Example:</b> The customer pays \$10.50 in cash.</p> <p>1 0 5 0 → AMT TOTAL</p>
<p><b>2 Enter additional payments.</b></p> <ul style="list-style-type: none"> <li>Repeat the steps above until the complete payment has been made.</li> </ul>	 <p>★AMOUNT    PCS02    BALANCE 60.00 2 PC    10.50    70.50</p> <p><b>Example:</b> The customer pays the balance by check.</p> <p>CHECK </p>

## 3.5 Subtotal Discount

### 3.5.1 Subtotal Amount Discount

The displays shown below have both a character and a segment display. However, the AC-3000E has only a segment display.

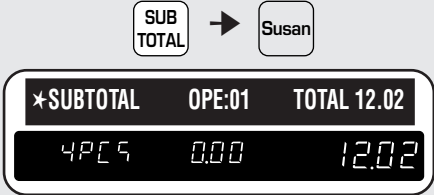
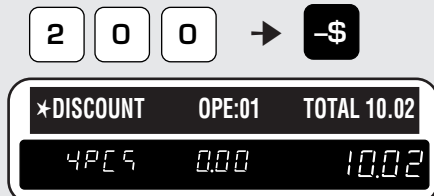
<p><b>1 Obtain the subtotal amount.</b></p> <ul style="list-style-type: none"> <li>Press the SUBTOTAL and OPERATOR (preset) keys.</li> </ul>	
<p><b>2 Perform discount operation.</b></p> <ul style="list-style-type: none"> <li>Enter the discount amount and press the AMOUNT DISCOUNT key.</li> </ul>	<p><b>Example:</b> Discount amount = \$2.00</p> 

### 3.5.2 Subtotal Percent Discount

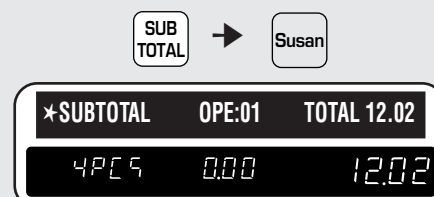
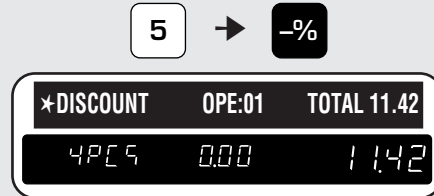

<p><b>1 Obtain the subtotal amount.</b></p> <ul style="list-style-type: none"> <li>Press the SUBTOTAL and OPERATOR (preset) keys.</li> </ul>	
<p><b>2 Perform discount operation.</b></p> <ul style="list-style-type: none"> <li>Enter the discount percentage and press the PERCENT DISCOUNT key.</li> </ul>	<p><b>Example:</b> Discount rate= 5%</p> 

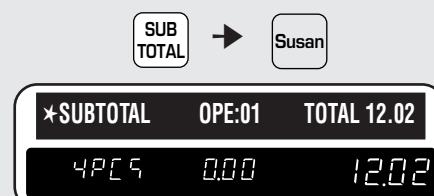
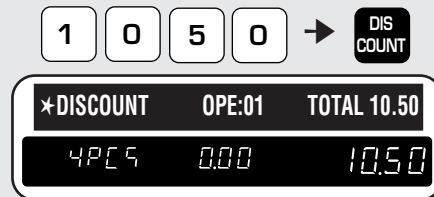
### 3.5.3 Subtotal Special Price

<p><b>1 Obtain the subtotal amount.</b></p> <ul style="list-style-type: none"> <li>Press the SUBTOTAL and OPERATOR (preset) keys.</li> </ul>	
<p><b>2 Perform special price operation.</b></p> <ul style="list-style-type: none"> <li>Enter the special price and press the DISCOUNT key.</li> </ul>	<p><b>Example:</b> Special price = \$10.50</p> 

## 3.6 Returned Item

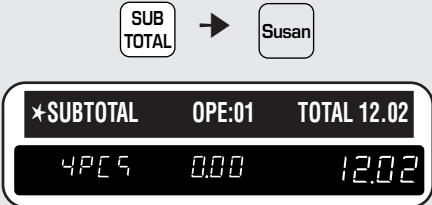
The displays shown below have both a character and a segment display. However, the AC-3000E has only a segment display.

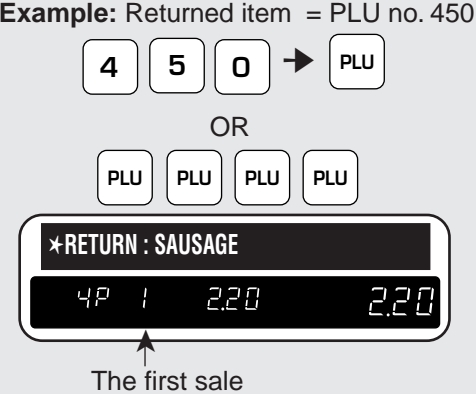
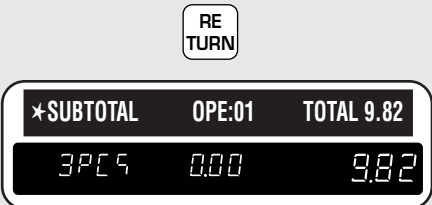
<p><b>1 Obtain the subtotal amount.</b></p> <ul style="list-style-type: none"> <li>Press the SUBTOTAL and OPERATOR (preset) keys.</li> </ul>	
<p><b>2 Enter the return mode.</b></p> <ul style="list-style-type: none"> <li>Press the RETURN key.</li> </ul>	
<p><b>3 Call up the returned item.</b></p> <ul style="list-style-type: none"> <li><b>Entering PLU number</b> <ul style="list-style-type: none"> <li>Enter the PLU number and press the PLU key, or press the Price Look-Up (preset) key.</li> </ul> </li> <li><b>Pressing PLU key</b> <ul style="list-style-type: none"> <li>Continue to press the PLU key until the item to be returned is displayed on the screen.</li> </ul> </li> </ul>	<p>Example: Returned item = PLU no. 450</p> 
<p><b>4 Finalize the transaction.</b></p> <ul style="list-style-type: none"> <li>Press the RETURN key again.</li> </ul>	

# CHAPTER 4

## ON-DEMAND OPERATION

### Contents

4.1	Mark Down Functions.....	30
4.1.1	Amount Discount .....	30
4.1.2	Percent Discount .....	30
4.1.3	Special Price .....	30
4.2	Unit Price Override .....	31
4.3	Voiding the Last Transaction .....	31
4.4	Changing from Weighed Item to Fixed-price Item .....	31
4.5	Fixed Weight Override .....	31
4.6	Date Override .....	32
4.7	Save .....	32
4.8	Logo Print .....	32
4.9	Store Name Print .....	33
4.10	Extra Text Print .....	33
4.11	POP Text Print .....	33
4.12	Coupon Text Print .....	34

---

## 4.1 Mark Down Functions

The following three mark down options are available. Only one of these three options may be used at one time. This function must be used when the PLU is displayed on the screen.

**Note:** The discounted amount or entered special price must be less than displayed total price.

### 4.1.1 Amount Discount

<p><b>1 Enter the discount amount.</b></p> <ul style="list-style-type: none"><li>▪ <b>Entering discount amount</b><ul style="list-style-type: none"><li>• Enter the amount to be discounted and press the AMOUNT DISCOUNT key.</li></ul></li><li>▪ <b>Pressing AMOUNT DISCOUNT (preset) key</b><ul style="list-style-type: none"><li>• Press the preset key in which the discount amount is set.</li></ul></li></ul>	<p><b>Example:</b> Discount amount = \$0.50</p> <p>5 0 → -\$</p> <hr/> <p>\$ -0.50</p>
--	--

### 4.1.2 Percent Discount

<p><b>1 Enter the discount percentage.</b></p> <ul style="list-style-type: none"><li>▪ <b>Entering discount percentage</b><ul style="list-style-type: none"><li>• Enter the percentage (1~99) to be discounted and press the PERCENTAGE DISCOUNT key.</li></ul></li><li>▪ <b>Pressing PERCENT DISCOUNT (preset) key</b><ul style="list-style-type: none"><li>• Press the preset key in which the percent discount data is set.</li></ul></li></ul>	<p><b>Example:</b> Discount percentage = 10%</p> <p>1 0 → -%</p> <hr/> <p>-10%</p>
--	--

### 4.1.3 Special Price

<p><b>1 Enter the special price.</b></p> <ul style="list-style-type: none"><li>• Enter the special price and press the DISCOUNT key.</li></ul>	<p><b>Example:</b> Special price = \$4.50</p> <p>4 5 0 → DISCOUNT</p>
--	---

## 4.2 Unit Price Override

This feature only functions for the weighed PLUs which are programmed to allow unit price override. This function must be used when the PLU is displayed on the screen.

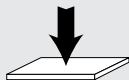
<b>1 Enter the desired unit price.</b>  <i>Note 1. If the entered unit price is not accepted at this point, possibly the PLU has not been programmed to allow price override.</i> <i>2. A warning beep will sound when trying to override a unit price while an item is on the scale.</i>	<b>Example:</b> New unit price = \$3.50  
<b>2 Place the item on the scale.</b>	

## 4.3 Voiding the Last Transaction



This function cancels the transaction of the previously printed label/receipt. This function must be used before calling up the next PLU.

The displays shown below have both a character and a segment display. However, the AC-3000E has only a segment display.

<b>1 Void the transaction.</b> <ul style="list-style-type: none"><li>• Press the VOID key.</li><li>• The previous label/receipt issue transaction will be canceled.</li><li>• The voiding display will be displayed for a few seconds.</li></ul>	
--	--

## 4.4 Changing from Weighed Item to Fixed-price Item

This function is used to change the mode from the weighed item to the fixed-price item. This function must be used when the PLU is displayed on the screen.

<b>1 Enter the fixed price.</b>  <i>Note: Skip this step if the fixed price is the same as the preset unit price.</i>	<b>Example:</b> Fixed price = \$8.00  
<b>2 Press the FIXED PRICE key.</b>	

## 4.5 Fixed Weight Override

This function is used to temporarily change a fixed weight of the fixed price item. This function must be used when the PLU is displayed on the screen.

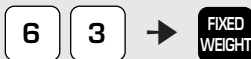
<b>1 Change the fixed weight.</b> <ul style="list-style-type: none"><li>• Enter the new weight and press the FIXED WEIGHT key.</li></ul>	<b>Example:</b> Current weight = 50 oz. New weight = 63 oz.  
--	---

## 4.6 Date Override

This function is used to temporarily change the current date.  
This function must be used when the PLU is displayed on the screen.

**Note:** This function is not available when printing in the receipt mode.

<p><b>1</b> Enter the date (MMDDYY) and press the DATE key.</p> <p><b>Note:</b> The scale may be configured at installation to override the expire date instead of the current date.</p> <p>M : Month D : Day Y : Year</p>	<p style="text-align: center;"><b>Example:</b> November 20, 1997</p> <p style="text-align: center;">1 1 2 0 9 7 → DATE</p>
--	--

## 4.7 Save

The SAVE key is one of the additional function options.  
During a transaction, the SAVE key can be used to maintain accessed PLU data that will be used repeatedly.  
This data is reset when the SAVE key is pressed again.

<p><b>1</b> Select the desired PLU if not already displayed.</p>	<p style="text-align: center;">Select PLU</p>
<p><b>2</b> Press the SAVE key. Then the SAVE indicator will light.</p> <p><b>Note:</b> To cancel the save mode, press the SAVE key again.</p>	<p style="text-align: center;"></p>

## 4.8 Logo Print

With this function, a preset logo can be selected and printed on the labels. This operation should be performed after the PLU has been accessed and before the label is issued. This function must be used when the PLU is displayed on the screen.

**Note:** This function is not available when printing in the receipt mode.

<p><b>1</b> Select the desired logo.</p> <ul style="list-style-type: none"><li>Enter the logo number and press the LOGO key.</li></ul> <p><b>Note</b> 1. When logo printing is not needed, press the "0" key followed by the LOGO key. 2. Label format must be configured to allow logo printing.</p> <p><b>Example:</b> Logo no. 2</p>	<p style="text-align: center;">2 → LOGO</p>
---	---

---

## 4.9 Store Name Print

With this function, a preset store name can be selected and printed on the labels. This operation should be performed after the PLU has been accessed and before the label is issued. This function can be used at any time.

**Note:** This function is not available when printing in the receipt mode.

<p><b>1 Select the desired store name.</b></p> <ul style="list-style-type: none"><li>Enter the store name number and press the STORE NAME key.</li></ul> <p><b>Example:</b> Store name no. 2</p>	
--	---

## 4.10 Extra Text Print

With this function, a preset extra text message can be selected and printed on the labels. This operation should be performed after the PLU has been accessed and before the label is issued. This function must be used when the PLU is displayed on the screen.

**Note:** This function is not available when printing in the receipt mode.

<p><b>1 Select the desired extra text.</b></p> <ul style="list-style-type: none"><li>Enter the extra text number and press the EXTRA TEXT key.</li></ul> <p><b>Note:</b> When extra text printing is not needed, press the "0" key followed by the EXTRA TEXT key.</p> <p><b>Example:</b> Extra text no. 10</p>	
---	--

## 4.11 POP Text Print

With this function, a preset POP text can be selected and printed on the labels. This operation should be performed after the PLU has been accessed and before the label is issued. This function must be used when the PLU is displayed on the screen.

**Note:** This function is not available when printing in the receipt mode.

<p><b>1 Select the desired POP text.</b></p> <ul style="list-style-type: none"><li>Enter the POP text number and press the POP TEXT key.</li></ul> <p><b>Note:</b> When POP text printing is not needed, press the "0" key followed by the POP TEXT key.</p> <p><b>Example:</b> POP text no. 6</p>	
--	---

---

## 4.12 Coupon Text Print

With this function, a preset coupon text can be selected and printed on the labels. This operation should be performed after the PLU has been accessed and before the label is issued. This function must be used when the PLU is displayed on the screen.

**Note:** This function is not available when printing in the receipt mode.

### 1 Select the desired coupon text.

- Enter the coupon text number and press the COUPON TEXT key.

**Note:** When coupon text printing is not needed, press the "0" key followed by the COUPON TEXT key.

**Example:** Coupon text no. 30



# CHAPTER 5

## SUBTRACTION

### Contents



5.1	Subtraction .....	36
-----	-------------------	----

## 5.1 Subtraction

The subtraction is used to subtract the transacted total from the running totals. The operator has to enter the PLU number, quantity, weight, and price. The recommended way to manage subtraction is to keep all incorrectly produced labels in one place and subtract each label in turn.

**Note:** Confirm that the Operation Key Sheet, and not the Program Key Sheet, is being used for this operation.

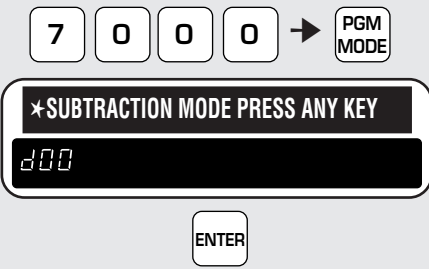
The displays shown below have both a character and a segment display. However, the AC-3000E has only a segment display.

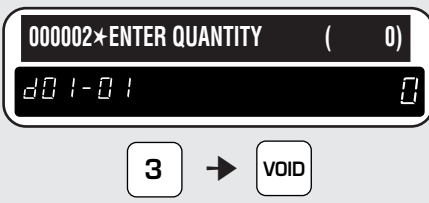
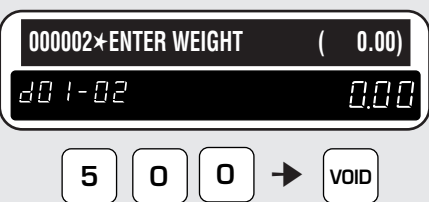
<p><b>1</b> Enter the subtraction mode.</p> <ul style="list-style-type: none"> <li>Enter the password followed by the PROGRAM MODE key to enter the subtraction mode.</li> </ul> <p><b>Example:</b> Password = 7 0 0 0</p> <p><b>Note:</b> To exit the subtraction mode, press the PROGRAM MODE key again.</p> <ul style="list-style-type: none"> <li>Press the ENTER key.</li> </ul>	
<p><b>2</b> Enter the PLU.</p> <ul style="list-style-type: none"> <li>Enter the PLU number followed by the PLU key.</li> </ul> <p><b>Example:</b> PLU no. 2</p>	
<p><b>3</b> Enter the quantity.</p> <ul style="list-style-type: none"> <li>Enter the quantity of the item (label) to be subtracted, and press the VOID key.</li> </ul> <p><b>Example:</b> Three (3) pcs.</p>	
<p><b>4</b> Enter the weight.</p> <ul style="list-style-type: none"> <li>Enter the weight of the item (label) to be subtracted, and press the VOID key.</li> </ul> <p><b>Example:</b> Five (5) pounds</p> <p><b>Note:</b> If a mistaken entry was made, use the VOID key to return to the screen with the mistake. Then enter the correct data.</p>	

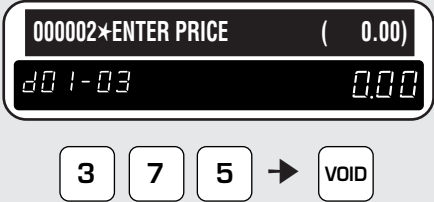
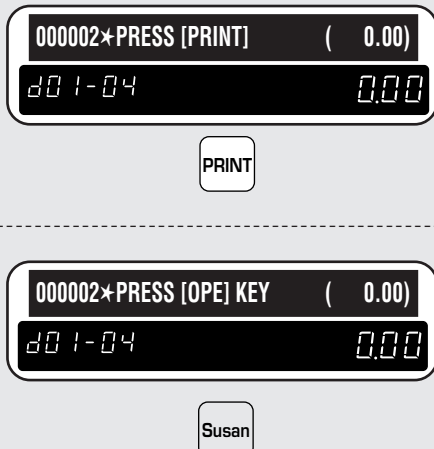
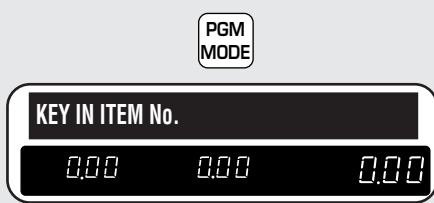
<p><b>5</b> Enter the price.</p> <ul style="list-style-type: none"> <li>Enter the price of the item (label) to be subtracted, and press the VOID key.</li> </ul> <p><b>Example:</b> \$3.75</p> <p><b>Note:</b> <i>If a mistaken entry was made, use the VOID key to return to the screen with the mistake. Then enter the correct data.</i></p>	
<p><b>6</b> Print</p> <ul style="list-style-type: none"> <li><b>When not using the operator system,</b> <ul style="list-style-type: none"> <li>Press the PRINT key.</li> </ul> </li> <li><b>When using the operator system,</b> <ul style="list-style-type: none"> <li>Press the OPERATOR (preset) key.</li> </ul> </li> </ul>	
<p><b>7</b> Repeat the transaction.</p> <ul style="list-style-type: none"> <li>Repeat steps 2 through 6 for any other items (labels) to be subtracted.</li> </ul>	
<p><b>8</b> Return to the initial display.</p> <ul style="list-style-type: none"> <li>Press the PROGRAM MODE key to return to the initial display.</li> </ul>	

# CHAPTER 6

## TROUBLESHOOTING

### Contents

6.1	Error Messages .....	40
6.2	How to Release Error Conditions ...	41
6.3	How to Replace Fuse .....	41
6.4	Other Problems .....	41

## 6.1 Error Messages

When errors occur, use the error table below to ascertain the cause of the error and to recover normal operations.

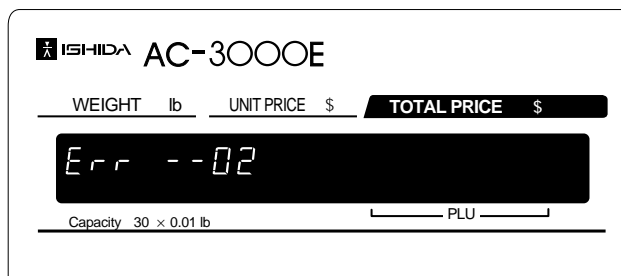
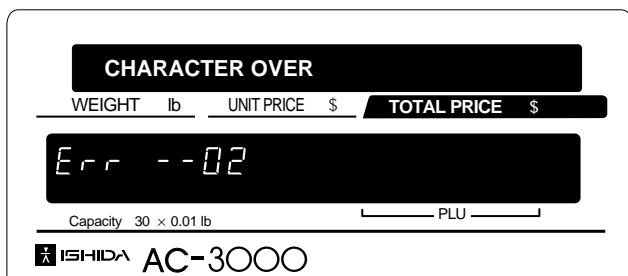

The displays shown below have both a character and a segment display. However, the AC-3000E has only a segment display.

Error No.	Error Message	Error Contents
01	<b>IMPROPER POSITION. CHECK CASSETTE</b>	The cassette is not in the correct position. (AC-3000 only)
02	<b>CHARACTER OVER</b>	PLU name has too many characters per line.
03	<b>POP MESSAGE: OVER CHARACTER</b>	Insufficient space for POP message.
04	<b>AD MESSAGE: OVER CHARACTER</b>	Extra text has too many characters per line.
06	<b>REG. CODE: OVER CHARACTER</b>	Insufficient space for register code.
07	<b>STORE NAME/ADDR.: OVER CHARACTER</b>	Store name and address have too many characters per line.
08	<b>LABEL END</b>	All labels have been used.
09	<b>LABEL SIZE ERROR</b>	Improper label size is used.
10	<b>PRICE DISCOUNT IS TOO LARGE</b>	The discounted price is incorrect.
11	<b>TABLE STRUCTURE CORRUPTION</b>	Table structure has become corrupted.
12	<b>MAX ITEM NUMBER OVERFLOW</b>	Maximum number of items exceeded. (receipt application only)
13	<b>SAME OPR. TOTALING ON MAC.</b>	An operator performed sub-total operation at a different scale.
14	<b>SAME OPR. PROCESSING ON OTHER</b>	The same operator code is used at a different scale.
40	<b>MEMORY NOT INITIAL SET</b>	Memory has not been initialized.
42	<b>SYSTEM ERROR</b>	A fundamental system error has occurred.
43	<b>E2ROM NOT INITIAL SET</b>	E2 ROM has not been initialized.
50	<b>NO POWER SCALE</b>	The internal cables are not properly connected.
56	<b>REMOVE THE ITEM ON THE PLATTER</b>	An item is on the platter when the power is turned ON.
57	<b>REMOVE THE ITEM ON THE PLATTER</b>	An item is on the platter when the power is turned ON.
9380	<b>COMM. ERROR ON RESULT TRANSFER</b>	Communication error when sending transaction data.
9330	<b>MASTER CONNECTION ERROR</b>	The master scale is not properly connected.
9300	<b>SYSTEM ERROR (CHECK CABLE)</b>	System error involving the cable has occurred.
9330	<b>SYSTEM ERROR (CHECK MASTER SCALE)</b>	System error involving the master terminal has occurred.
9316	<b>MASTER IS OFF-LINE</b>	The master scale is not on-line.
66	<b>MEMORY AREA OVERFLOWED</b>	Too much data is in the memory area.
9309	<b>ERROR ON COMM. CROSSOVER</b>	The same transaction data is received by the master scale.

---

## 6.2 How to Release Error Conditions

- If an error occurs for any reason, use the **CLEAR** key to release the error condition.
- If trouble occurs during operations and you are unable to return to normal operation, use the **RESET** key to re-initialize the scale. (This operation produces the same effect as turning the power off and then restarting.)

## 6.3 How to Replace Fuse

If the display does not light when the power is on, this may indicate a problem with the fuse. Use the procedure below to check and replace the fuse.

- (1) Turn off the power, and unplug the power cord from AC outlet.
- (2) Use a Philips head screw driver to remove the fuse holder cover located by ON/OFF switch.
- (3) Check whether or not the fuse has blown.
- (4) If the fuse has blown, replace with the same type of fuse.

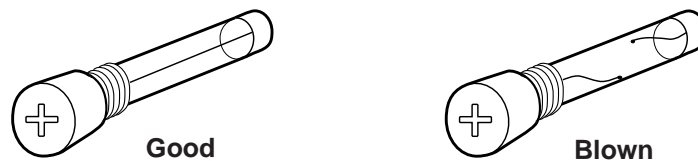

- (5) Return and secure the fuse holder cover.
- (6) Plug the power cord into AC outlet, and turn on the scale.

## 6.4 Other Problems

- **Poor printing quality.**  
The thermal head has become soiled. Use the supplied cleaner set to clean the printer head.
- **Labels are not printed as soon as an item is placed on the weigh platter.**  
The scale is set in the MANUAL mode. (AUTO indicator is not lit.)  
Press the PREPACK key to turn on the AUTO indicator.
- **Labels are not issued.**  
The printing position may not be properly set. Press the PAPER FEED key to align the paper to the correct printing position.



---

**ISHIDA CO., LTD.**

44 SANNO-CHO, SHOGOIN, SAKYO-KU  
KYOTO, 606 JAPAN  
PHONE: (075) 771-4141  
FACSIMILE: (075) 751-1634  
TELEX: 05422065 SCALES J