



---

*Digital Diagnostic Junction Box*  
*Version 1.4*

# Installation Manual



DISCONTINUED

# Contents

<b>About This Manual .....</b>	<b>1</b>
<b>1.0 Introduction.....</b>	<b>1</b>
1.1 System Configurations and Options.....	2
<b>2.0 Installation.....</b>	<b>3</b>
2.1 Unpacking and Assembly .....	3
2.2 Mounting the Enclosure.....	3
2.3 Cable Connections .....	3
2.4 Load Cells .....	3
2.5 Serial Communications .....	5
2.6 Primary/Secondary Configuration .....	5
2.7 Digital I/O.....	8
2.8 Analog Output .....	9
2.9 Core Module DIP Switches .....	10
2.10 Core Module Reset Procedure .....	10
2.11 iQUBE Communications Configurations.....	11
2.11.1 Copper-Wire Connection to the 920i.....	11
2.11.2 Fiber-Optic and Ethernet Communications .....	11
2.11.3 Remote Fiber-Optic Module (PN 77789) .....	12
2.11.4 Analog Output .....	13
2.12 Installing Tap and Run Connectors for 920i Power.....	14
2.13 Installing the Optional Power Supply .....	15
2.14 Installing Option Cards.....	15
2.14.1 Digital-to-Analog (DAC) Conversion Cards .....	15
2.14.2 iQUBE Internal Fiber-Optic Option.....	15
2.14.3 iQUBE Internal Ethernet Option.....	15
2.14.4 920i Internal Fiber-Optic Option .....	16
2.15 Fuse Replacement .....	16
2.16 Parts Kit Contents .....	16
2.17 Replacement Parts and Assembly Drawings .....	17
<b>3.0 920i Indicator Configuration.....</b>	<b>20</b>
3.1 Configuration Methods .....	20
3.2 920i-iQUBE Menu Configuration .....	20
3.3 Configuration and Calibration Summary.....	21
3.4 iQUBE-Specific Menu Structures and Parameter Descriptions.....	22
3.4.1 SERIAL Menu, iQUBE Submenu.....	22
3.4.2 iQUBE Submenu, IQDIAG Parameters .....	25
3.4.3 PFORMT Menu.....	28
<b>4.0 PC Configuration.....</b>	<b>29</b>
4.1 Using Revolution III .....	29
4.1.1 Revolution III Configuration .....	29
4.1.2 Downloading to the iQUBE .....	30
4.2 Using iRev .....	30



Technical training seminars are available through Rice Lake Weighing Systems. Course descriptions and dates can be viewed at [www.rlws.com](http://www.rlws.com) or obtained by calling 715-234-9171 and asking for the training department

<b>5.0</b>	<b>Calibration .....</b>	<b>31</b>
5.1	920i Front Panel Calibration . . . . .	31
5.1.1	Theoretical Calibration . . . . .	31
5.1.2	Cal-Match Calibration . . . . .	31
5.1.3	Manual Trim Factor Adjustment (Tweaking) . . . . .	32
5.1.4	Final Calibration . . . . .	32
5.2	Revolution III Calibration. . . . .	32
<b>6.0</b>	<b>Diagnostics .....</b>	<b>34</b>
6.1	iQUBE Diagnostic . . . . .	34
6.2	Cell Mate Relationships . . . . .	34
6.3	Diagnostic Tests . . . . .	34
6.4	Diagnostic Setup . . . . .	36
6.4.1	Configuring the 920i Diagnostics Softkey . . . . .	36
6.4.2	920i Diagnostic Display. . . . .	36
6.5	Error Messages . . . . .	36
<b>7.0</b>	<b>Alerts .....</b>	<b>38</b>
7.1	Network Alert Notification . . . . .	38
7.2	Alert Format. . . . .	39
7.3	FEATURE Menu, CONTACT Submenu . . . . .	40
7.4	PFORMT Menu . . . . .	41
<b>8.0</b>	<b>920i Serial Commands .....</b>	<b>42</b>
<b>9.0</b>	<b>Appendix .....</b>	<b>45</b>
9.1	Troubleshooting. . . . .	45
9.1.1	General Steps. . . . .	45
9.1.2	Technical Assistance Guide and Questionnaire. . . . .	46
9.2	Printed Information . . . . .	48
9.3	Flash Update Procedure . . . . .	49
9.4	Software Version Updates . . . . .	50
9.5	Specifications . . . . .	50
	<b>iQUBE Limited Warranty.....</b>	<b>51</b>

# About This Manual

---

This manual is intended for use by service technicians responsible for installing and servicing 920i™ digital diagnostic junction boxes. This manual applies to Version 2145 or later of the *iQUBE* software and Version 2.05 or later of the 920i indicator software.

Configuration and calibration of the *iQUBE* can be accomplished using the *Revolution III* configuration utility.

For installations using the 920i indicator, the indicator can be configured using the *Revolution III* or *iRev*™ configuration utilities, serial commands, or the 920i indicator front panel keys.

## 1.0 Introduction

---

The *iQUBE* is a digital programmable junction box used to connect up to 16 full bridge analog load cells. The *iQUBE* outputs a serial stream that can be directly input to the 920i indicator using copper, fiber-optic, or Ethernet cabling. Alternatively, the *iQUBE* can be configured to provide an analog output signal for input to standard digital weight indicators.

The *iQUBE* is available in three models:

- Four-channel
- Eight-channel
- Eight-channel with eight digital I/O channels

The basic *iQUBE* consists of two boards:

- The *connector board* provides the physical connections for the load cells, serial communications, analog output, and digital I/O.
- The *core module*, which plugs into the connector board, contains the *iQUBE*'s processor and stores configuration and calibration data for the *iQUBE*. The core module provides a discrete A/D for each channel input and converts the analog load cell signal to a digital serial output.

Up to four *iQUBE* units can connect and communicate as a multidrop RS-485 network, consisting of one primary and up to three secondary *iQUBE* units. The maximum number of load cells supported for the 920i indicator is 16. Up to four individual weighing platforms can be configured for a scale system.

The *iQUBE* can be configured and calibrated through the 920i indicator (Version 2.05 or later), the 920i's *iRev* configuration utility, or by using the *iQUBE* module of the *Revolution III* configuration utility.



### Warning

Some procedures described in this manual require work inside the *iQUBE* or indicator enclosure. These procedures are to be performed by qualified service personnel only.



Authorized distributors and their employees can view or download this manual from the Rice Lake Weighing Systems distributor site at [www.rlws.com](http://www.rlws.com).

### **iQUBE Options**

Options for the *iQUBE* include the following;

**Internal power supply:** The 6 VDC power supply mounts inside the *iQUBE* enclosure and requires a 115/230 VAC input. This option is required for applications that do not use the 920i indicator and for 920i applications that use more than two *iQUBE* units, the distance between the 920i and the master *iQUBE* is more than 75 feet, or the fiber optic modules are used.

**Analog output:** This option consists of a DAC card that mounts on the core module and converts the *iQUBE*'s digital output stream to 0–30 mV or 0–20 mA (passive only).

**Fiber-optic transceiver:** This option mounts on the connector board to convert the *iQUBE*'s serial output into visible light for fiber-optic interface. When used with the optional power supply, the fiber-optic interface provides electrical isolation of the *iQUBE* from the host.

**Fiber-optic transceiver to analog output:** This option converts digital fiber-optic data received from the *iQUBE* to an analog signal that can be input to the load cell input of a standard weight indicator.

**Ethernet:** This option mounts on the connector board to transfer the *iQUBE*'s serial output onto the Ethernet.

### **Configuration**

There are two methods for configuration, using either the 920i indicator as the host (menu or *iRev* configuration) or by using the *Revolution III* utility to configure the *iQUBE* directly. Each method defines the load cells connected to *iQUBE*, which load cells comprise a platform, and which platforms make up the scale system.

Configuration consists of the following steps:

**Define Load Cells:** This is the electrical sensitivity (mV/V output) and capacity specification of the load cells. Load cell names and serial number can also be specified.

**Define Platforms:** A platform is a contiguous weigh bridge. Any *iQUBE* board can assign load cells to two separate platforms. A maximum of four platforms can be defined in an *iQUBE* system. The relationship between load cells is also defined as a paired or circular arrangement.

**Define Systems:** The platforms can be assigned to a system. Up to four unique systems can be defined, however the *920i* will only support one system per serial channel.

### Load Cell Trimming and Calibration

Cal-Match™ calibration calculates the load cell trim based on a comparison of the signal generated by an applied weight for each load cell to the signal generated by all other load cells. If a known test weight value is used, this calibration also sets the span for the scale.

Three types of Cal-Match calibration can be performed using the *iQUBE*. Each type of calibration captures the initial dead load of the scale and provides a means to trim the outputs of the load cells.

**Cal-Match Theoretical calibration** allows each cell to be zeroed and trim factors calculated. Based on the cell capacity and sensitivity, the *iQUBE* calculates weight values based on the total signal from all of the cells.

**Cal-Match Section calibration** requires a weight to be placed over each section. Trimming can be performed by running a weight cart down the middle of the platform, stopping for calibration of each section.

**Corner calibration** requires weight to be placed over each cell individually. Corner trimming can be performed for platforms using an even or odd number of cells.

### Diagnostics (Error 2)

Diagnostic functionality can be enabled for the *iQUBE* to identify abnormal load cell outputs. This is based on the reference established through cell associations. The diagnostic conditions that can be identified for paired configurations are open bridge or channel, zero reference tolerance, drifting, peak-to-peak noise, and out-of-balance conditions. Diagnostic conditions recognized for circular configurations are limited to open bridge or channel, drifting, and peak-to-peak noise.

Error conditions generate a displayed error message if connected to the *920i* which, with an Ethernet card, can be configured to e-mail the alert message to an address. In addition, there is a visual LED indication on the connector board to identify any load cell that appears to have an abnormal condition.

### Cell Emulation

Cell emulation allows the output of a failed load cell to be emulated. Automatic or manual cell emulation can be specified (limited to one cell per scale system), using either truck scale (Type 1) or tank/hopper/floor scale (Type 2) emulation algorithms.

**NOTE:** Satisfactory results from cell emulation require the load to be centered and the scale installation to be plumb and level.

## 1.1 System Configurations and Options

Table 1-1 lists *iQUBE* model and option part numbers. *920i* part numbers listed are for models without A/D cards.

Model / Option	PN
4-channel <i>iQUBE</i>	92391
8-channel <i>iQUBE</i>	92392
8-channel <i>iQUBE</i> with digital I/O	92393
<i>iQUBE</i> internal power supply, 6 VDC	77531
<i>iQUBE</i> internal Ethernet interface	77142
<i>iQUBE</i> internal fiber-optic interface	77143
<i>920i</i> internal fiber-optic interface	77788
<i>920i</i> internal Ethernet communications card	71986
<i>920i</i> Serial option card	67604
Remote (external) fiber-optic interface	77789
Analog output, 0–30 mV	77146
Analog output, 0–20 mA (passive)	77797
<i>920i</i> universal model, 115 VAC	77790
<i>920i</i> universal model, 230 VAC	77791
<i>920i</i> deep enclosure, w/out A/D model, 115 VAC	93243
<i>920i</i> deep enclosure, w/out A/D model, 230 VAC	93244
<i>920i</i> panel mount model, 115 VAC	77792
<i>920i</i> panel mount model, 230 VAC	77793
<i>920i</i> wall mount model, 115 VAC	77794
<i>920i</i> wall mount model, 230 VAC	77795

Table 1-1. *iQUBE* Model and Option Part Numbers

## 2.0 Installation

This section describes procedures for connecting load cell, analog output, power, and serial communications cables to the *iQUBE* junction box. Assembly drawings and replacement parts lists for the *iQUBE* are included for the service technician.

**Caution** Use a wrist strap to ground yourself and protect components from electrostatic discharge (ESD) when working inside the *iQUBE* enclosure.

### 2.1 Unpacking and Assembly

Immediately after unpacking, visually inspect the *iQUBE* to ensure all components are included and undamaged. The shipping carton should contain the *iQUBE*, this manual, and a parts kit. If any parts were damaged in shipment, notify Rice Lake Weighing Systems and the shipper immediately.

See Section 2.16 on page 16 for parts kit contents.

### 2.2 Mounting the Enclosure

The *iQUBE* can be mounted either vertically or horizontally to a flat surface.

### 2.3 Cable Connections

All models of the *iQUBE* provide ten cord grips for cabling into the unit, plus a dedicated cord grip for a ground wire. Up to eight load cells can be cabled into the *iQUBE*; other cord grips allow cabling for serial communications, analog output, digital I/O, and AC power. Install plugs in all unused cord grips to prevent moisture from entering the enclosure.

### 2.4 Load Cells

When wiring load cells, cells wired to *iQUBE* connectors J12–J19 (8-channel units) are assigned default names A1–A8 (8-channel primary unit) or B1–B8 (8-channel secondary unit). Be aware that graphic representations of the weighing platform shown when configuring the scale assume particular locations for each load cell, based on the *iQUBE* connector used (see Table 2-1). Load cells can be renamed during configuration.

Channels 1–4		Channels 5–8 (8-channel units only)	
<i>iQUBE</i> Connector	Cell Name	<i>iQUBE</i> Connector	Cell Name
J12	A1	J16	A5
J13	A2	J17	A6
J14	A3	J18	A7
J15	A4	J19	A8

NOTE: For secondary *iQUBE* units, the A prefix is replaced with B, C, or D.

Table 2-1. *iQUBE* Connector and Load Cell Names

Figure 2-1 shows two examples of load cell naming for eight-cell platforms. While load cells can be wired to any connector on the *iQUBE* connector board, platforms defined as using “paired” sections (including most truck scale applications) must correctly associate these pairs to ensure valid calibration and diagnostic functions.

In the top example of Figure 2-1, the even/odd load cell wiring scheme requires cells A1/A2, A3/A4, A5/A6, and A7/A8 to be associated as section pairs. In the lower example, the sequential wiring requires pair associations for A1/A8, A2/A7, A3/A6, and A4/A5. Pair association is set in the platform configuration for the scale.

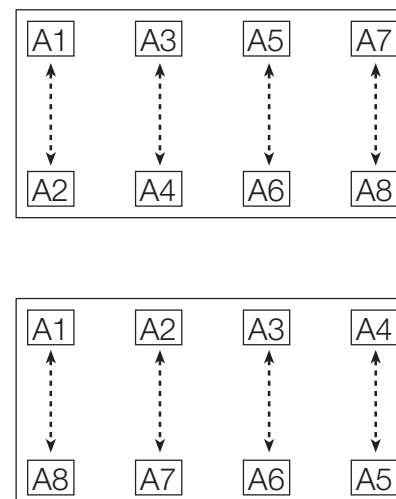

Figure 2-1. Load Cell Pairing for Eight-Cell Platforms

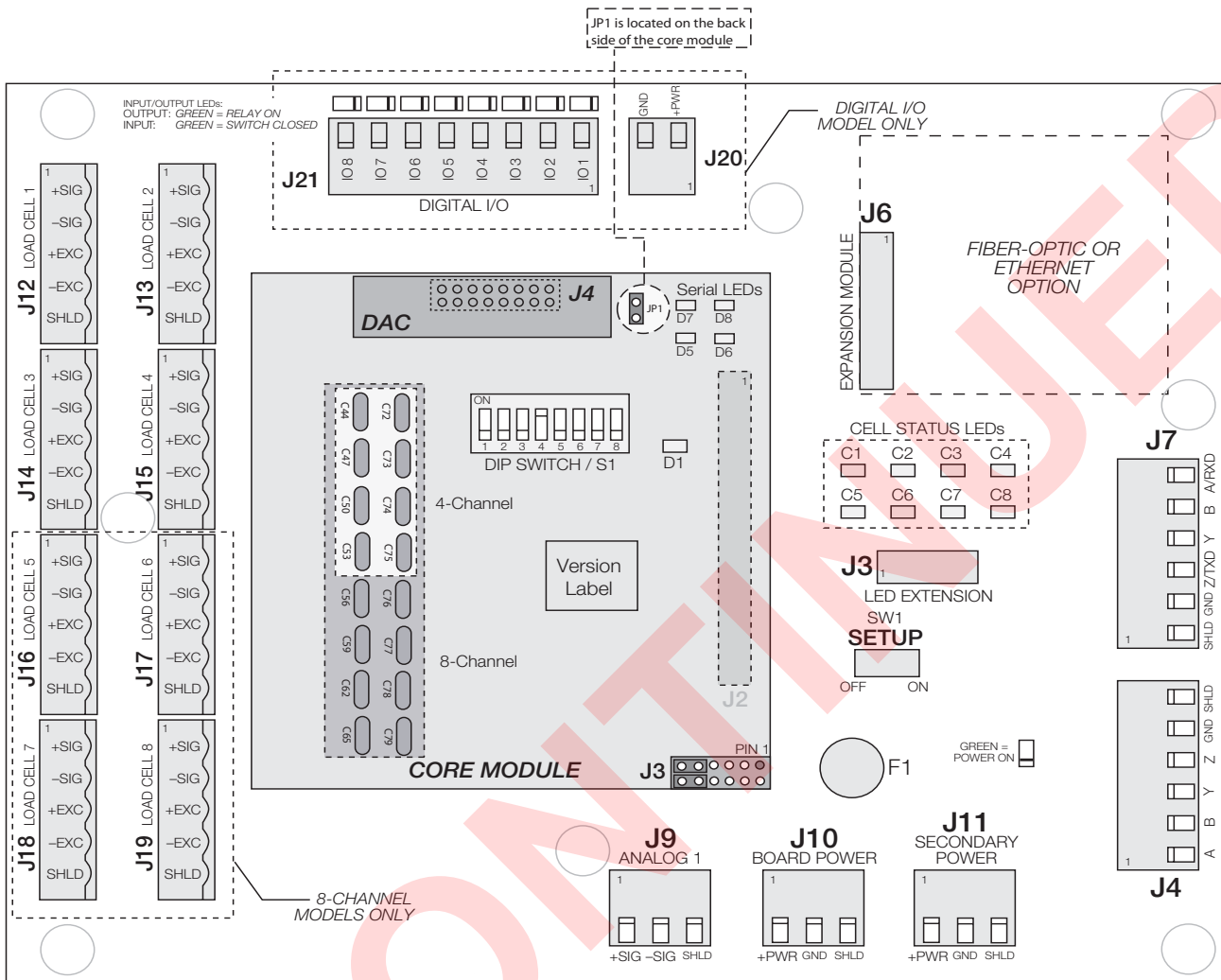

Figure 2-2. iQUBE Connector Board (8-channel with Digital I/O) with Core Module and DAC Card

### Load Cell Wiring

To attach load cell cables to the connector board, route the cables through the cord grips on the load cell connector end of the iQUBE enclosure. Note the load cell numbering assigned to the connectors (see Figure 2-2).

Strip 1/4-inch of insulation from the ends of the load cell wires. Use the cable clamp tool included in the parts kit to open the connector springs and install wires into the connectors. Wire load cell cables as shown in Table 2-2.

When connections are complete, use cable ties and mounts to secure the load cell cables to the inside of the enclosure.

Load Cell Connector Pins (J12–J19)	Function
1	+SIG
2	–SIG
3	+EXC
4	–EXC
5	SHIELD

Table 2-2. Load Cell Connector Pin Assignments

## 2.5 Serial Communications

The J4 and J7 serial communications ports on the *iQUBE* connector board support communications between the *iQUBE* and a host device (indicator or PC) or other *iQUBE* units.

- Port J7 supports full-duplex RS-232 or four-wire RS-485 communications between the primary *iQUBE* unit and a host device. The communications protocol (RS-232 or RS-485) and port used to communicate with the host device are selected by setting DIP switches on the core module (see Section 2.9 on page 10).

**NOTE:** Four-wire RS-485 communications with the *920i* requires installation of the serial option card in the indicator. See Table 2-4.

Port J7 is also used by secondary *iQUBE* units to connect to the master and secondary unit.

- Port J4 supports full-duplex RS-485 communication between the primary *iQUBE* unit and any secondary *iQUBE*, and between successive secondary units (see Section 2.6).

To attach serial communications cables, route the cable through the cord grip and wire to the connector. Use cable ties to secure serial cables to the inside of the enclosure.

Table 2-3 shows the pin assignments for connectors J4 and J7. See Section 2.6 for information about wiring for secondary units.

Connector	Pin	Signal
J7	1	SHIELD
	2	GND
	3	Z / RS-232 TxD
	4	Y
	5	B
	6	A / RS-232 RxD
J4	1	A (RS-485 +RxD)
	2	B (RS-485 -RxD)
	3	Y (RS-485 +TxD)
	4	Z (RS-485 -TxD)
	5	GND
	6	SHIELD

Table 2-3. Serial Port Pin Assignments

### RS-485 Connections to Host 920i

Table 2-4 shows the connections needed for RS-485 communications between a host *920i* and the *iQUBE*. The *920i* serial expansion card, PN 67604, must be installed in the indicator for 4-wire RS-485 communications with the *iQUBE*.

920i Serial Option Board J2 Connector		<i>iQUBE</i> J7 Connector	
RS-485 Signal	Pin	Pin	RS-485 Signal
+RxD	1	4	+TxD (Y)
-RxD	2	3	-TxD (Z)
-TxD	3	5	-RxD (B)
+TxD	4	6	+RxD (A)

Table 2-4. RS-485 Connections for 920i Host

**NOTE:** RS-485 is only supported on Port A of the 2-channel expansion board.

### Communications Cable Distance Limitations

The maximum cable lengths that can be used for various communications types depend on a number of factors. These include: output impedance of the transmitter; electrical noise in the environment; cable capacitance, gauge, termination, and shielding.

Given that these and other factors will affect the maximum usable cable length, the following distances can be used as a general guide for *iQUBE* communications cabling:

RS-232:	50 ft (15 m)
RS-485:	1000 ft (300 m) (Twisted pair cable)
Fiber-optic:	500 ft (150 m)

## 2.6 Primary/Secondary Configuration

Up to three *iQUBE* junction boxes can be configured as secondary units controlled by a primary *iQUBE* unit. Figure 2-4 on page 7 shows the primary-to-secondary wiring for multiple *iQUBE* units. Successive secondary units are wired in parallel (A to A, B to B, and so on) as shown in Figure 2-5.

### NOTES:

- 120Ω termination resistors (included in parts kit) must be installed across the A and B terminals on the J4 connector of the primary unit and between the A and B terminals on the J7 connector of the *last* secondary unit (see Figure 2-4 on page 7).
- All six wires, including shield and ground wires, must be connected between the communicating *iQUBE* units.

DIP switches on the core module of each *iQUBE* must be set to indicate whether the unit is a primary or secondary, the communication protocol and port used, and the secondary address.

- For the primary unit, DIP switches 1–3 must all be set OFF. Set switches 5 and 6 based on the protocol (RS-232 or RS-485) and port (J7 or J6) used to communicate with the host device.
- For secondary units, DIP switch 5 must be set ON; use switches 1–3 to set the secondary address as shown in Table 2-5.

DIP Switch	Primary Unit	Secondary Unit
1–3	OFF, OFF, OFF	ON, OFF, OFF = SECONDARY1 OFF, ON, OFF = SECONDARY2 ON, ON, OFF = SECONDARY3
5	RS-232 = OFF RS-485 = ON	ON
6	OFF = J7 ON = J6	<i>iQUBE</i> Port

Table 2-5. Core Module Communications DIP Switches

See Section 2.9 on page 10 for more information about the core module DIP switches.

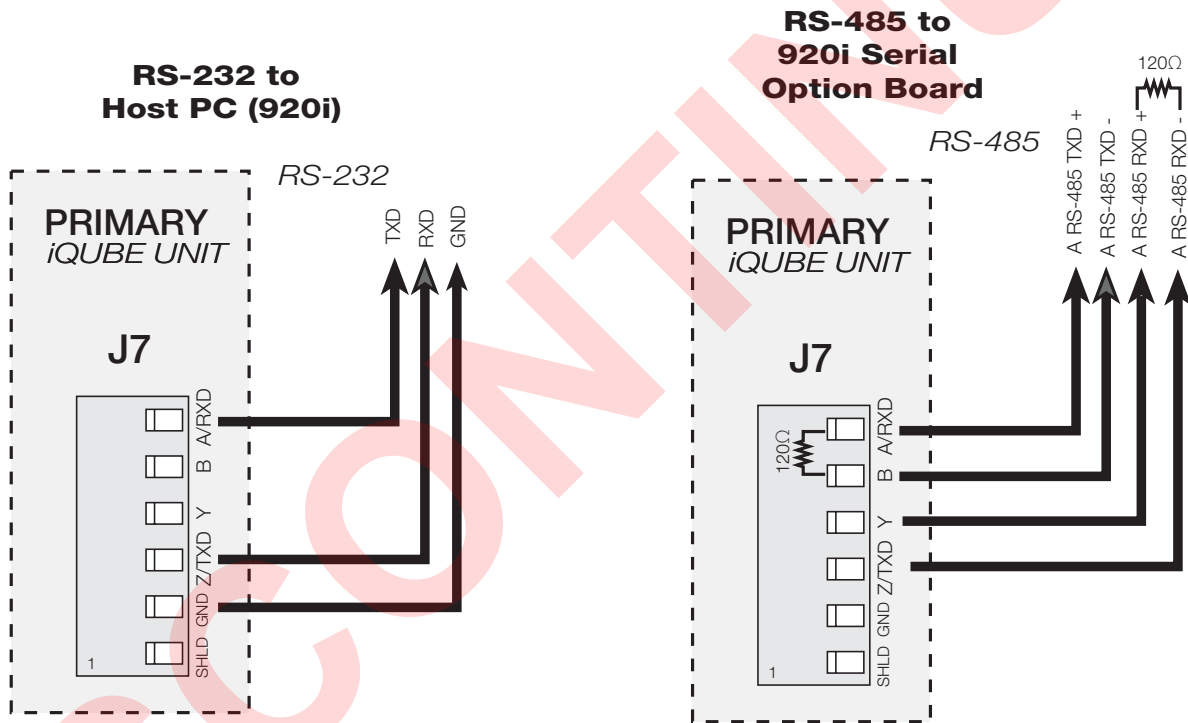

Figure 2-3. 920i Wiring

**NOTE!**  
 ALL SIX WIRES, INCLUDING SHIELD  
 AND GROUND WIRES, MUST BE  
 CONNECTED FOR COMMUNICATION  
 BETWEEN IQUBE UNITS

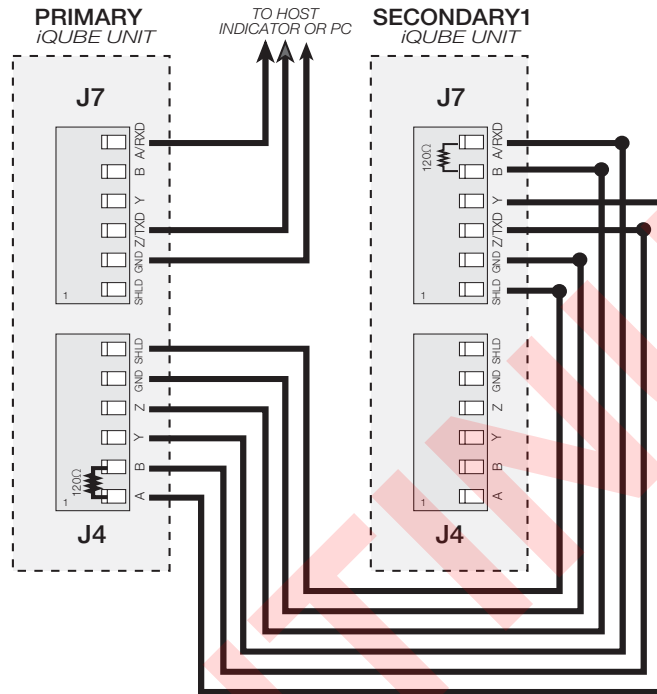

Figure 2-4. Primary-to-Secondary Communications Wiring

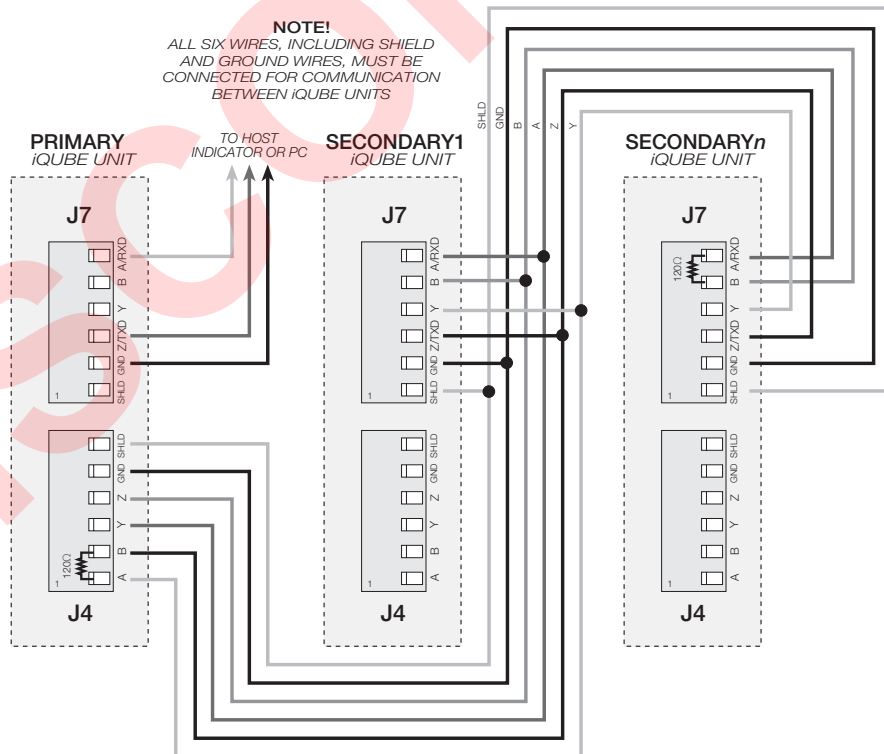

Figure 2-5. Primary-to-Multiple Secondary Communications

## 2.7 Digital I/O

The *iQUBE* junction box is available with support for eight channels of digital I/O.

Digital inputs can be set to provide many indicator functions, including all keypad functions. Digital inputs are active low (0 VDC), inactive high (5 VDC).

Digital outputs are typically used to control relays that drive other equipment. Outputs are designed to sink, rather than source, switching current.

Each output is a normally-open collector circuit, capable of sinking 25 mA when active. Digital outputs are wired to switch relays when the digital output is active (low, 0 VDC) with reference to a 5 VDC supply. Auxiliary power is available at connector J20 (see Figure 2-2 on page 4).

Table 2-6 shows the pin assignments for connector J21.

J21 Pin	J21 Signal
1	I/O 1
2	I/O 2
3	I/O 3
4	I/O 4
5	I/O 5
6	I/O 6
7	I/O 7
8	I/O 8

Table 2-6. J21 Pin Assignments (Digital I/O)

Digital inputs and outputs for the 920i indicator are configured using the DIG I/O menu.

## 2.8 Analog Output

The analog output option consists of either a 0-30mV (PN 77146) or 0-20mA (PN 77797) digital-to-analog (DAC) card that plugs into the *iQUBE* core module. The 0–30 mV output simulates the output of a load cell or standard junction box, allowing connection to standard indicators. A 0–20 mA (passive only) DAC is also available for PLC applications. The 0-20mA and the 0-30mV DAC cards connect to J4 on the *iQUBE* core module. See Figure 2-6 for J4 location.

**NOTE:** Analog output setup information is supplied with the *920i*, *VIRTUi*, or *Revolution III* technical documentation.

Analog output from the *iQUBE* is sent to connector J9 on the connector board (see Figure 2-2 on page 4). See Section 2.14.1 on page 15 for more information about installing the analog output option.

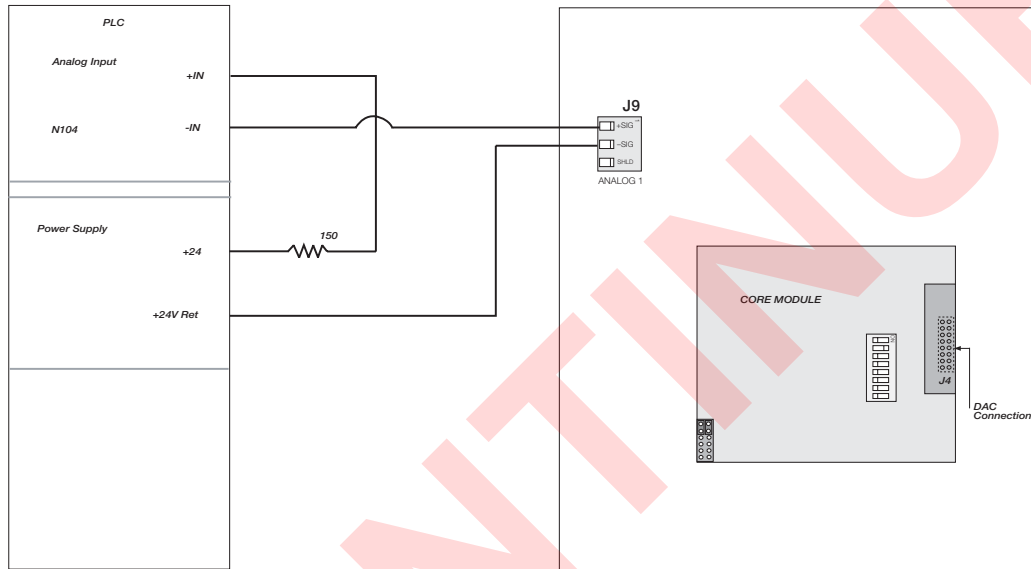

Figure 2-6. 0-20mA Analog Output Wiring

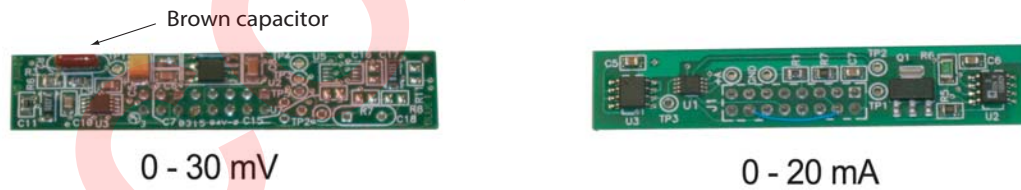

Figure 2-7. 0 - 30mV and 0 - 20mA Converters

## 2.9 Core Module DIP Switches

The DIP switches on the *iQUBE* core module must be set to configure the *iQUBE* as a primary or secondary unit, and to specify the type of serial communications provided by the unit. Table 2-7 lists the DIP switches and their functions.

Switch	Function	Values
1-3	Primary/ secondary address	OFF, OFF, OFF = PRIMARY ON, OFF, OFF = SECONDARY1 OFF, ON, OFF = SECONDARY2 ON, ON, OFF = SECONDARY3
4	Setup enable/ disable	OFF = setup disabled ON = setup enabled
5	Host communication protocol	OFF = RS-232 ON = RS-485
6	Host communication port	OFF = Port J7 ON = Port J6
7	<i>Reserved</i>	—
8	Load default	Load default configuration on power-up (see Section 2.10)

Table 2-7. Core Module DIP Switch Settings

## 2.10 Core Module Reset Procedure

To reload the default firmware into the *iQUBE* core module, do the following:

1. Power-off the *iQUBE*. Remotely powered units can be powered off by temporarily removing fuse F1 (see Figure 2-2 on page 4).
2. Set core module DIP switch 8 ON.
3. Power-on the *iQUBE*. Allow LED D1, on the core module, to cycle from red to green or green to red several times, then off.
4. Power-off the *iQUBE*.
5. Set DIP switch 8 OFF.
6. Power-on the *iQUBE*. The reset is now complete.

## 2.11 iQUBE Communications Configurations

The following sections describe some of the ways digital or analog output from the *iQUBE* can be connected to weight indicators.

### 2.11.1 Copper-Wire Connection to the 920i

A basic configuration of the *iQUBE* is shown in Figure 2-8. A single 6-conductor load cell cable can be used both to supply 6 VDC power to the *iQUBE* and to exchange serial data with the *920i* indicator. Tap and run connectors included in the *iQUBE* parts kit are used to tap power from the indicator power supply (see Section 2.12 on page 14). **NOTE:** Applications using more than two *iQUBE* units must use the *iQUBE*'s optional internal power supply.

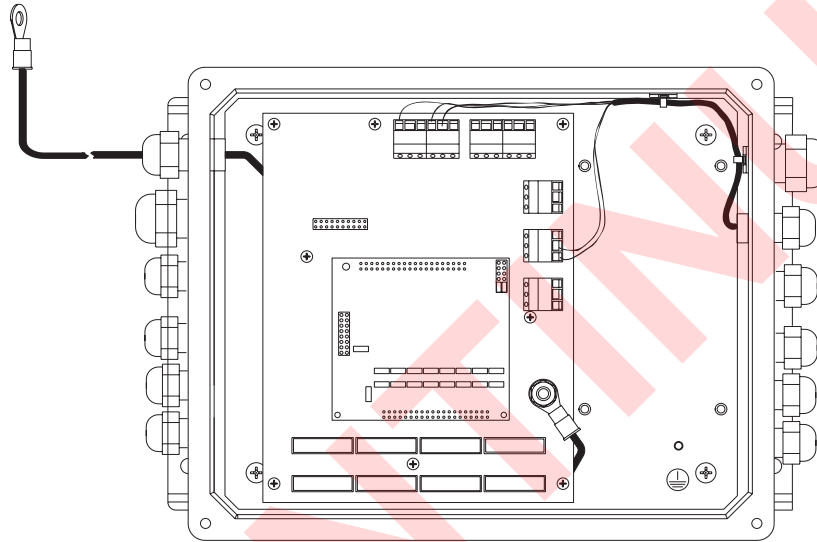

Figure 2-8. *iQUBE* Copper Wire Connection to *920i*, Showing RS-232 and DC Power Connections

### 2.11.2 Fiber-Optic and Ethernet Communications

Both fiber-optic and Ethernet communications cards are available for the *iQUBE*. Figure 2-9 shows an *iQUBE* unit with the fiber-optic card and the optional internal power supply installed.

An internal fiber-optic module for the *920i* (see Figure 2-18 on page 16) allows direct fiber-optic communication between the *iQUBE* and the *920i*. The optional remote fiber-optic interface can also be used to convert digital data carried on a fiber-optic cable from the *iQUBE* to an analog signal for any weight indicator.

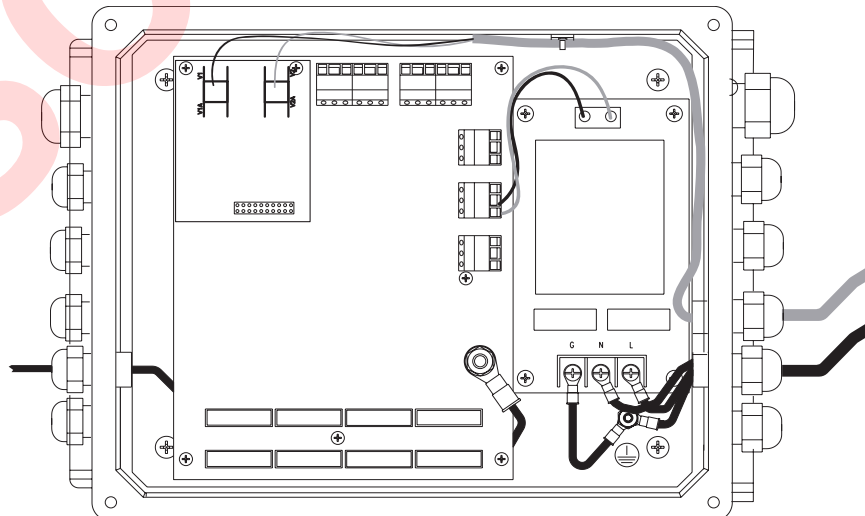

Figure 2-9. *iQUBE* Fiber-Optic Connection to *920i* or Remote Fiber Module

### 2.11.3 Remote Fiber-Optic Module (PN 77789)

The optional remote fiber-optic module provides optically isolated digital-to-analog (DAC) conversion of digital data received from the *iQUBE*. The analog output from the module can be connected to the analog (load cell) signal input of a standard weight indicator that can read 0-30mV (0-20mA) referenced to ground (see Figure 2-10).

This option requires that the *iQUBE* be fitted with its internal fiber-optic card (see Figure 2-9 on page 11); both voltage- and current-based DAC cards available for the remote fiber-optic module.

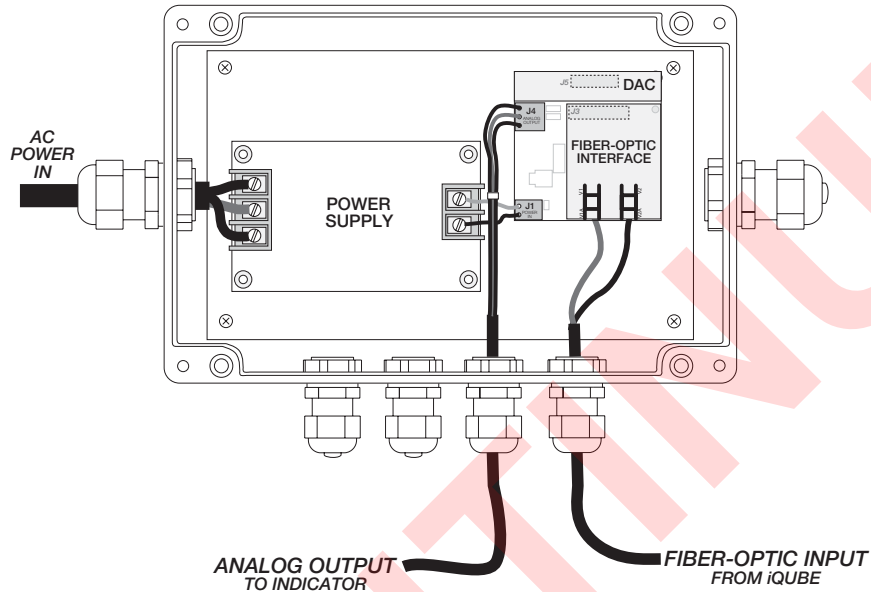

Figure 2-10. Remote Fiber-Optic Module

Figure 2-11 shows connector locations on the remote fiber-optic interface.

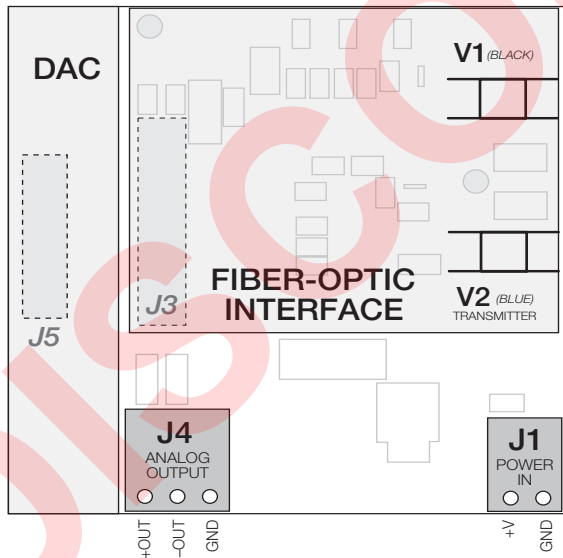

Figure 2-11. Remote Fiber-Optic Interface, Including DAC

### 2.11.4 Analog Output

The analog output from the *iQUBE* can be connected to the analog signal inputs of any weight indicator that can be read 0-30mV (0-20mA) referenced to ground (see Figure 2-12). Analog output from the *iQUBE* requires that a digital-to-analog (DAC) card be installed on the *iQUBE* core module. Both voltage- and current-based DAC cards are available. See Section 2.14.1 on page 15 for more information about DAC card installation.

**NOTE:** Analog output wiring *must include ground wire* (pin 3 on connector J9 on the *iQUBE* connector board).

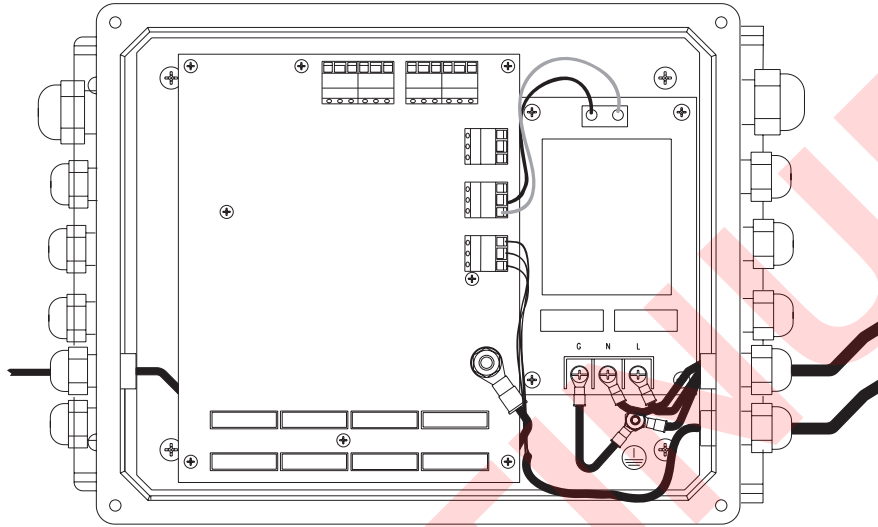

Figure 2-12. *iQUBE* Analog Output Connection to Indicator

## 2.12 Installing Tap and Run Connectors for 920i Power

*iQUBE* installations that are remotely powered by the 920*i* indicator, and those that use the 920*i* internal fiber-optic module, require tap and run connectors to draw power from the 920*i* power supply (see Figures 2-13 and 2-14).

To install tap and run connectors in the 920*i* indicator, do the following:

1. Place red (+6V) wire from 920*i* power supply inside the run channel of the tap and run connector. The cable tie used to secure the power supply wires may need to be cut to allow sufficient slack in the wires.

2. Close side cover of connector until latched.
3. Insert tap wire (+6V supply to *iQUBE*) into connector. Use inspection port to check wire position.
4. Use crimping tool to drive u-contact down flush with top of connector. Close hinged top cover until latched.
5. Repeat procedure for green (GND) wire tap and run connector.
6. Use cable ties to secure power supply wires inside the enclosure.

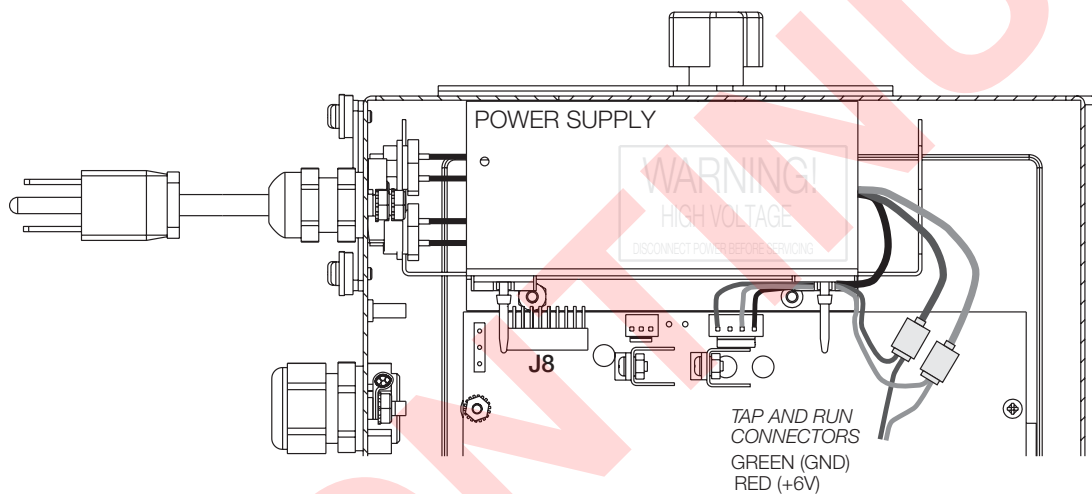

Figure 2-13. 920*i* Tap and Run Connector Installation

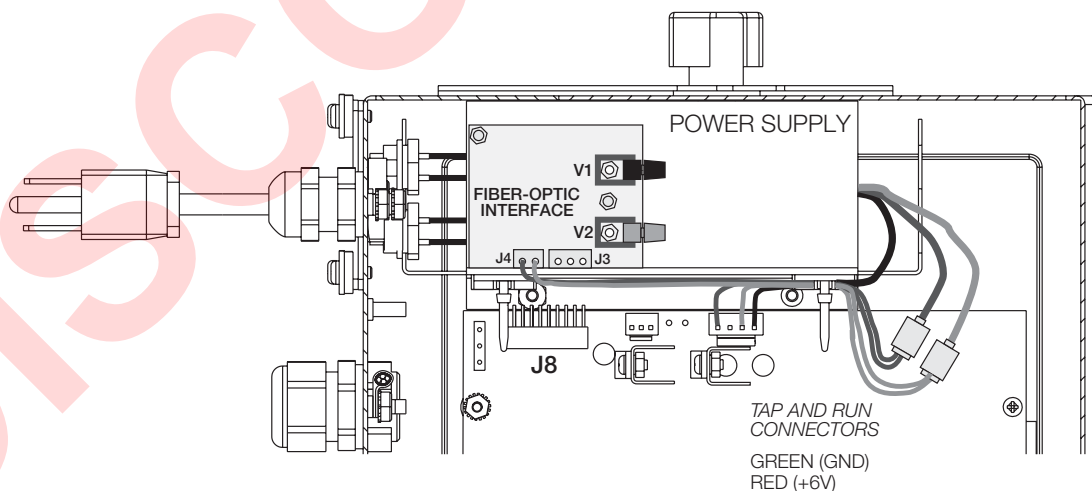

Figure 2-14. 920*i* Tap and Run Connector Installation for Internal Fiber-Optic Interface

See Section 2.14.4 on page 16 for more information about installing the 920*i* internal fiber-optic interface.

## 2.13 Installing the Optional Power Supply

The optional internal power supply provides 6VDC power for the *iQUBE* from 115 or 230 VAC power sources. It is required for *iQUBE* configurations that include the Ethernet option or that consist of more than two *iQUBE* units. Fiber-optic configurations can use the internal power supply to provide electrical isolation from the indicator.

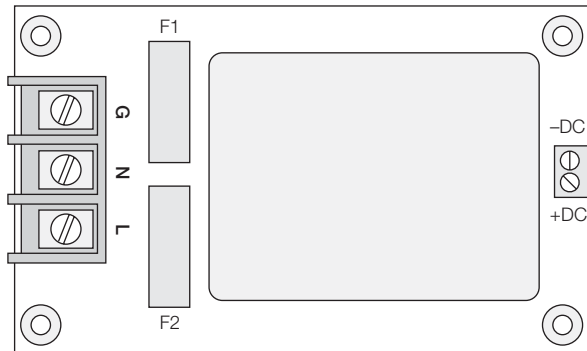

Figure 2-15. Optional *iQUBE* 6V Power Supply

**NOTE:** When using DC source that is between 8 - 16 volts, remove jumper JP1, located on the back side of the core module. See Figure 2-2 on page 4.

## 2.14 Installing Option Cards

General procedures for *iQUBE* option cards are described below:

**Caution** *Option cards are not hot-pluggable. Disconnect power to the iQUBE before installing option cards.*

### 2.14.1 Digital-to-Analog (DAC) Conversion Cards

Two DAC cards are available for both the *iQUBE* and the remote fiber-optic module:

- PN 77146, 0–30 mV DAC
- PN 77797, 4–20 mA DAC

For DAC cards to be installed in either the *iQUBE* or the remote fiber-optic module, orient the DAC card so that, when installed, its edge is aligned with the edge of the core module (*iQUBE*) or the fiber-optic interface board (remote fiber-optic module).

Carefully align the DAC card connector with the board connector (J4 on the core module, J5 on the remote fiber-optic interface board). Press down to seat the DAC in the board connector.

See Figure 2-2 on page 4 for core module location; see Figure 2-10 on page 12 for remote fiber-optic interface location.

### 2.14.2 *iQUBE* Internal Fiber-Optic Option

To install the internal *iQUBE* fiber-optic interface card, carefully align the option card connector with connector J6 on the connector board (see Figure 2-2 on page 4). Press down to seat the option card in the connector.

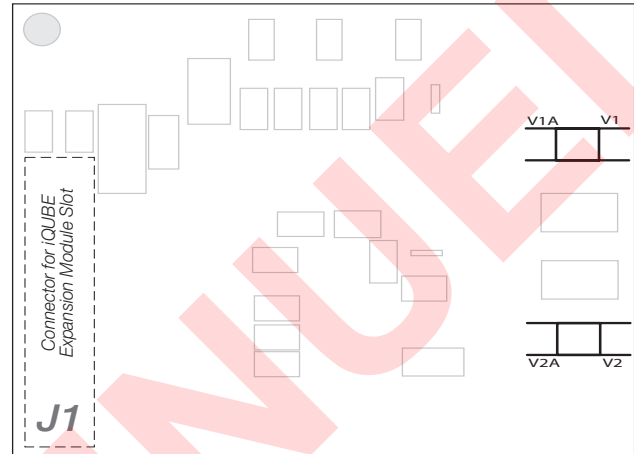

Figure 2-16. *iQUBE* Internal Fiber-Optic Option Card

### 2.14.3 *iQUBE* Internal Ethernet Option

To install the internal *iQUBE* Ethernet cards, carefully align the option card connector with connector J6 on the connector board (see Figure 2-2 on page 4). Press down to seat the option card in the connector.

**NOTE:** The optional internal *iQUBE* power supply is required for configurations that include the Ethernet option.

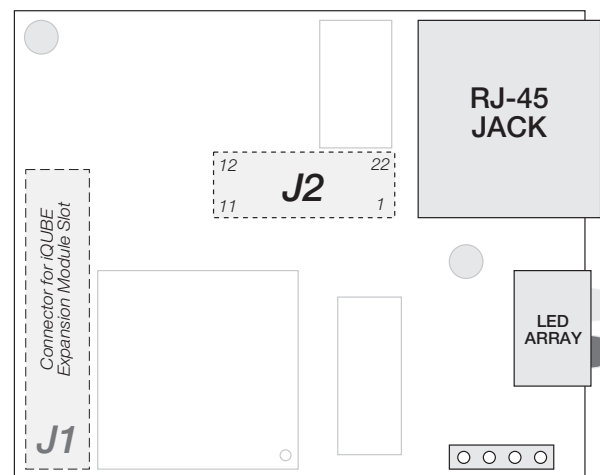

Figure 2-17. *iQUBE* Internal Ethernet Option Card

### 2.14.4 920i Internal Fiber-Optic Option

To install the 920i internal fiber-optic interface, position the adhesive square on the top of the 920i power supply shield (see Figure 2-14 on page 14). Press the fiber-optic interface backplate onto the adhesive square, then install the interface board onto the backplate.

Attach fiber-optic cables to connectors V1 (receive) and V2 (send). Attach RS-232 communications cables from connector J3 on the fiber-optic interface to any available 920i serial port. Use cable ties to secure communications cables inside the indicator enclosure.

Power to the 920i internal fiber-optic interface is provided by tap and run connectors on the +6V and GND wires between the 920i power supply and the indicator CPU board. Attach power supply wires to connector J4 on the fiber-optic interface. See Section 2.12 on page 14 for installation information.

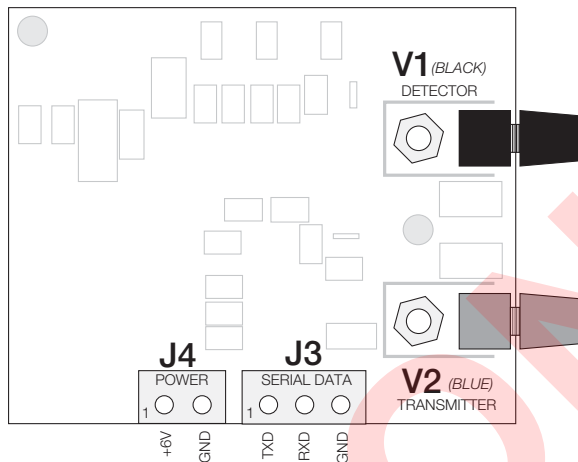

Figure 2-18. 920i Internal Fiber-Optic Option Card

## 2.15 Fuse Replacement

Fuse F1 on the *iQUBE* connector board (see Figure 2-2 on page 4) provides protection for power supplied to the connector board and core module at connector J10. See Section 9.5 on page 50 for complete fuse specifications.



### Caution

To protect against the risk of fire, replace fuses only with same type and rating fuse.

## 2.16 Parts Kit Contents

Table 2-8 lists the parts kit contents for the *iQUBE*.

PN	Description
15631	Cable ties, 3-in. nylon (15)
15650	Cable tie mounts, 3/4-in. (7)
15665	Reducing glands, 1/2-in. NPT (10)
19538	Cord grip plugs (6)
42350	Capacity label (1)
60940	120Ω resistors for RS-485 termination (2)
67063	Enclosure mounting tabs (4)
71349	1-in. polycarbonate breathing filter (1)
77925	<i>Revolution III</i> configuration software CD (1)
78476	Cage clamp tools for load cell connectors (2)
80331	Tap and run connectors (2)
83937	<i>iQUBE</i> Technical video (1)
77224	Installation manual (1)

Table 2-8. Parts Kit Contents

## 2.17 Replacement Parts and Assembly Drawings

Table 2-9 lists replacement parts for the *iQUBE* models, including all parts referenced in Figures 2-19 and 2-20.

Ref Number	PN	Description (Quantity)	
1	92938	<i>iQUBE</i> cover decal (1)	See Figure 2-19 on page 18
3	14822	Machine screws, 4-40NC x 1/2 (8)	
4	77140	<i>iQUBE</i> connector board, 4-channel (1)	
	77139	<i>iQUBE</i> connector board, 8-channel (1)	
	77727	<i>iQUBE</i> connector board, 8-channel with digital I/O (1)	
5	14637	Nuts (for power ground), 1/4-20NC (2)	
6	31546	1/4-in. internal tooth lock washers (for power ground) (3)	
7	14729	Bolt (for power ground), 1/4-20NC x 3/4 hex head (1)	
8	15655	Cable grip, 3/8 NPT (9)	
9	15656	Lock nut, 3/8 NPT (10)	
10	15628	Cord grips, 1/2-in. NPT (10)	
11	15630	Lock nuts, 1/2-in. NPT (10)	
12	91785	<i>iQUBE</i> enclosure (1)	See Figure 2-20 on page 19
18	77248	<i>iQUBE</i> core module, 4-channel (1)	
	77247	<i>iQUBE</i> core module, 8-channel (1)	
19	16892	Ground/Earth label (1)	
21	91896	Mounting panel assembly (1)	
—	71027	Fuse F1 (see Figure 2-2 on page 4). 2A time-lag, Wickmann TR5, type 374 (1)	
—	83052	Splice connector for fiber-optic cable	
—	77224	Installation manual (1)	
—	77925	<i>Revolution III</i> configuration software CD (1)	
—	83897	<i>iQUBE</i> Technical video (1)	
<p> <b>Caution</b> To protect against the risk of fire, replace fuses only with same type and rating fuse. See Section 9.5 on page 50 for complete fuse specifications.</p>			

Table 2-9. Replacement Parts

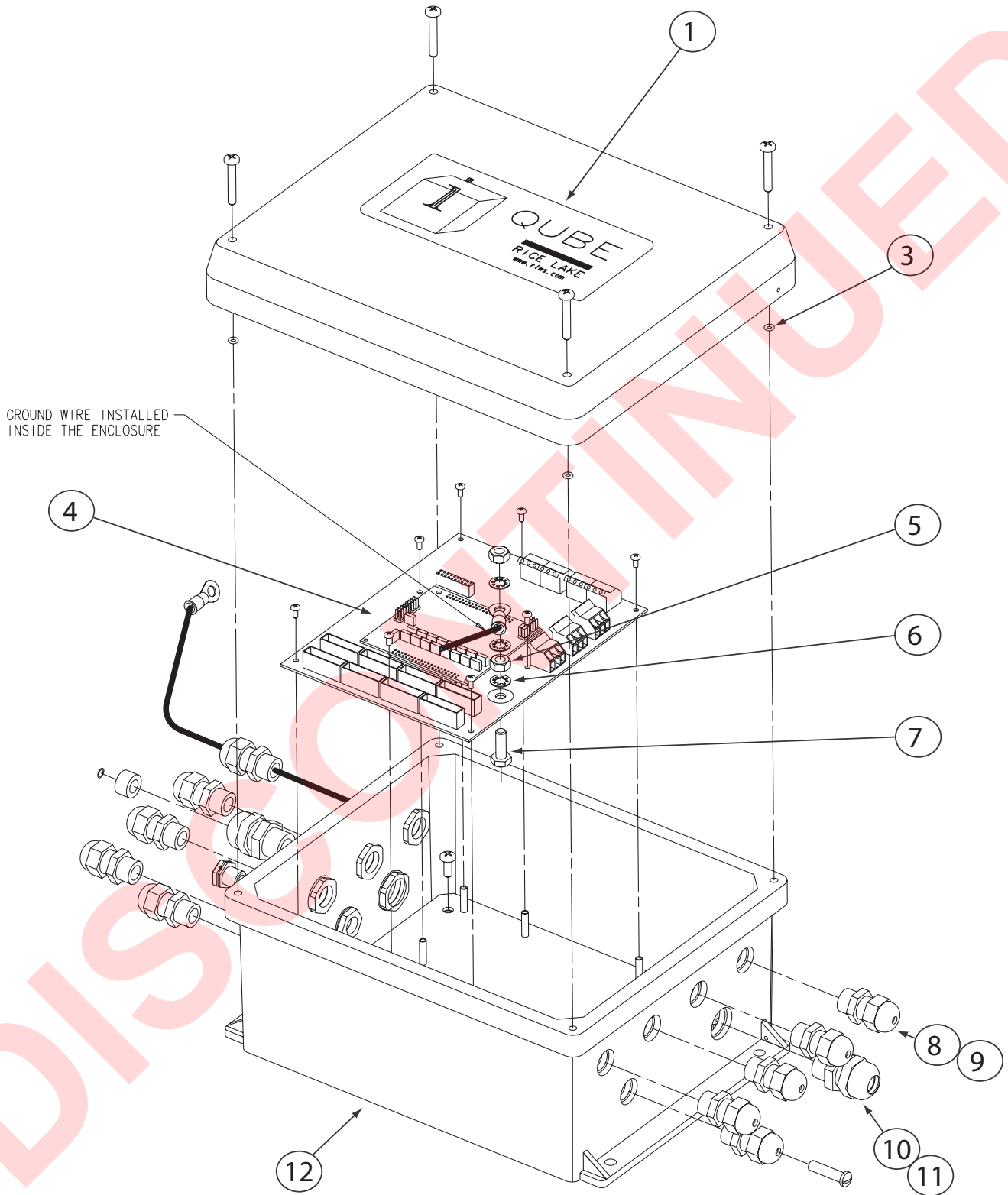

Figure 2-19. iQUBE Enclosure Assembly

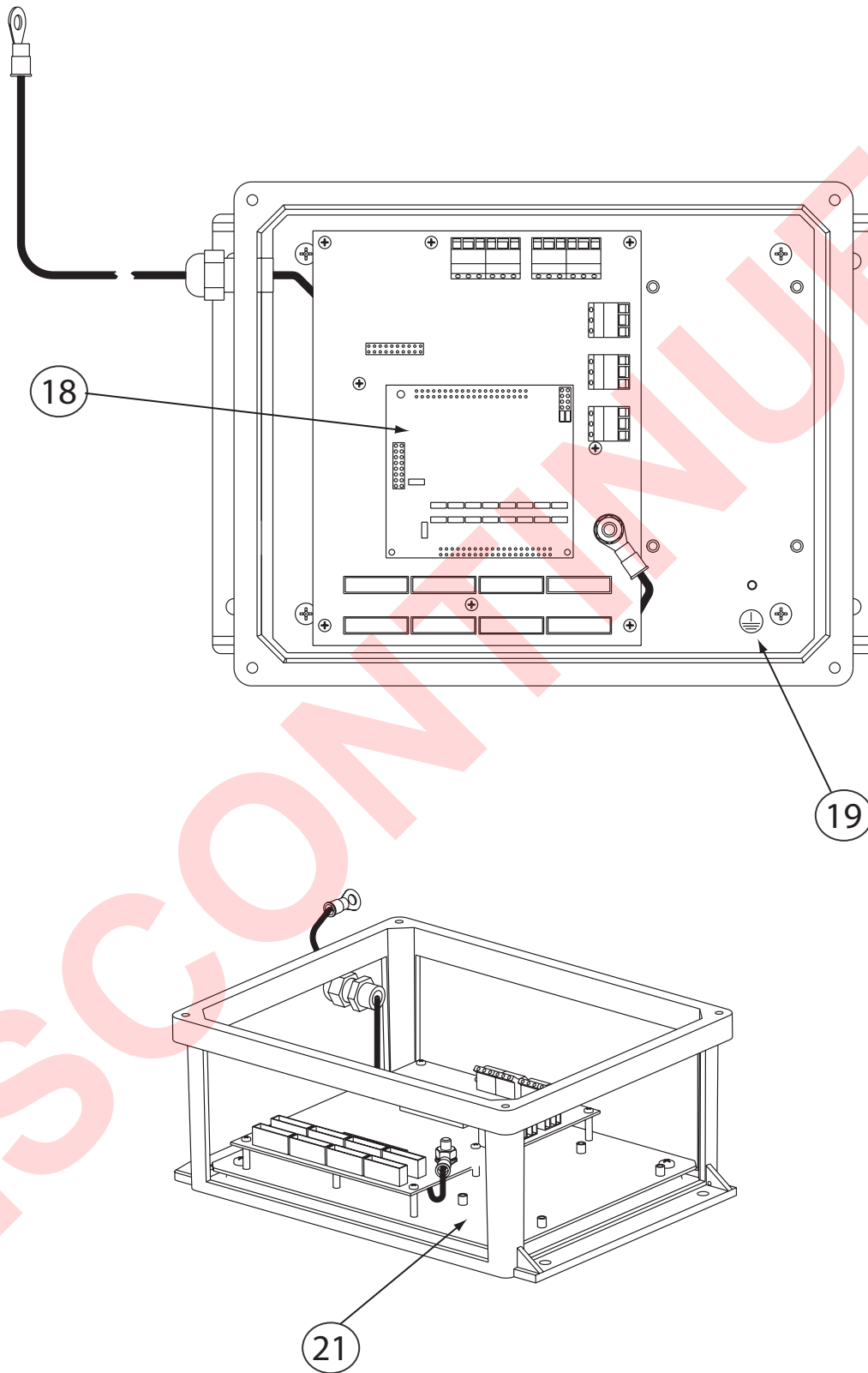

Figure 2-20. iQUBE Assembly

## 3.0 920i Indicator Configuration

---

To configure the 920i indicator, the indicator must be placed in setup mode. The setup switch is accessed by removing the large fillister head screw on the desktop and universal enclosures. Switch position is changed by inserting a screwdriver into the access hole and pressing the switch.

When the indicator is placed in setup mode, a series of menus is shown across the top of the display, along with the words *Scale Configuration*. The SCALES menu is highlighted as the first used to configure the indicator. See the *920i Installation Manual* for complete information.

When configuration is complete, press the **Exit** or **Save and Exit** softkey to exit setup mode, then replace the setup switch access screw.

- The **Exit** softkey exits setup mode without saving parameter changes to NV RAM. Changes made to the configuration remain in the system until indicator power is cycled.
- **Save and Exit** writes all parameter changes to flash memory before returning to normal mode.

### 3.1 Configuration Methods

The *iQUBE* can be configured for use with the 920i indicator by using the indicator front panel keys to navigate through a series of configuration menus or by sending commands or configuration data to an indicator serial port. Configuration using the menus is described in Section 3.4 on page 22.

Configuration using the serial port can be accomplished using either the serial commands described in the *920i Installation Manual* and Section 8.0 on page 42 of this manual, or by using the *iRev* configuration utility (see Section 4.0 on page 29).

**NOTE:** Some configuration parameters, such as those used to configure the 920i display and widgets, cannot be accessed through the configuration menus. *iRev* provides the most complete and efficient configuration interface for the 920i.

### 3.2 920i-iQUBE Menu Configuration

With both the *iQUBE* and the indicator powered off, connect Port 3 (or higher) of the indicator serial port to pins 2, 3, and 6 of connector J7 on the *iQUBE* connector board.

Power up the indicator and the *iQUBE*. Use the setup switches to place both the *iQUBE* and the indicator in setup mode.

1. Use the SERIAL menu to set up the following parameters. See Figure 3-2 on page 22 for a diagram of this portion of the 920i SERIAL menu. See also Table 3-1 on page 23.

**CONFIG:** Use the CONFIG parameter to select the *iQUBE* board and cell configuration. For example, a system with an 8-channel primary board and no secondary units is designated 8/0/0/0; an 8-channel primary board with a 4-channel secondary is designated 8/4/0/0.

**CELLS:** Enter load cell IDs, capacities, factory sensitivity values, and serial numbers. Load cell capacities and sensitivities are the only required parameters.

**SECTION:** Specify the relationship between cells as paired (PAIR) or circular (CIRC). Platforms with an odd number of cells must specify CIRC.

**PLATFM:** The platform setup display is divided into three areas:

- Platform (middle section): Highlight the platform being configured, then use the **left** arrow key to move to the Available Cells section.
- Available Cells (left section): Use this section to assign cells to the platform. Use the **up** and **down** keys to highlight the desired cell, then use the **Add** softkey to associate the cells with the platform. *Order of assignment is important!* See Section 2.3 on page 3 for information about the load cell build order.
- Associated Cells (right section): Lists cells that have been assigned to the platform. You can use the **Remove** softkey to remove cells from the platform. As cells are moved to the Associated Cells side a section diagram of the platform is displayed in the center of the screen.

Press **Done** when all required cells have been assigned to the platform.

SYSTEM: The system setup display is divided into three areas:

- System (middle section): Highlight the system being configured, then use the **left** arrow key to move to the Available Platform section.
- Available Platforms (left section): Use this section to assign platforms to the system. Use the **up** and **down** keys to highlight the desired platform, then press the **Add** softkey to assign the platform to the system.
- Associated Platforms (right section): Lists platforms that have been assigned the system. A system diagram is displayed in the center of the screen.

Press **Done** to return to the configuration menu.

2. Press the **Download** softkey. Use the **up** and **down** keys to select *Download iQUBE configuration only*, then press **enter**.
3. Cycle power on the *iQUBE* to initialize the changed configuration.
4. Press the **Save and Exit** softkey.
5. Return the *920i* to setup mode.
6. Continue configuration of the indicator as described in the *920i Installation Manual*.

Other *iQUBE-920i* functions and setup information are described in the sections listed below:

- Calibration: see Section 5.0 on page 31
- Contact information: see Section 7.3 on page 40
- Diagnostic setup: see Section 3.4.2 on page 25 and Section 6.0 on page 34
- Alert messaging: see Section 7.0 on page 38

### 3.3 Configuration and Calibration Summary



Figure 3-1. Configuration and Calibration Summary

### 3.4 iQUBE-Specific Menu Structures and Parameter Descriptions

The following sections provide graphic representations of *iQUBE*-specific *920i* menu structures and tables describing the menu parameters. Default values are shown in **bold** type; numeric ranges and string values are shown in *italic* type. Parameters shown surrounded by a dotted-line box only appear under the special circumstances explained under each box.

**NOTE:** Port 3 is the default port for most print formats. If the *iQUBE* is attached to the *920i* using port 3, ensure that the serial print format is not also routed to port 3. Use the *PORT* parameter to change the print format serial port assignment.

#### 3.4.1 SERIAL Menu, iQUBE Submenu

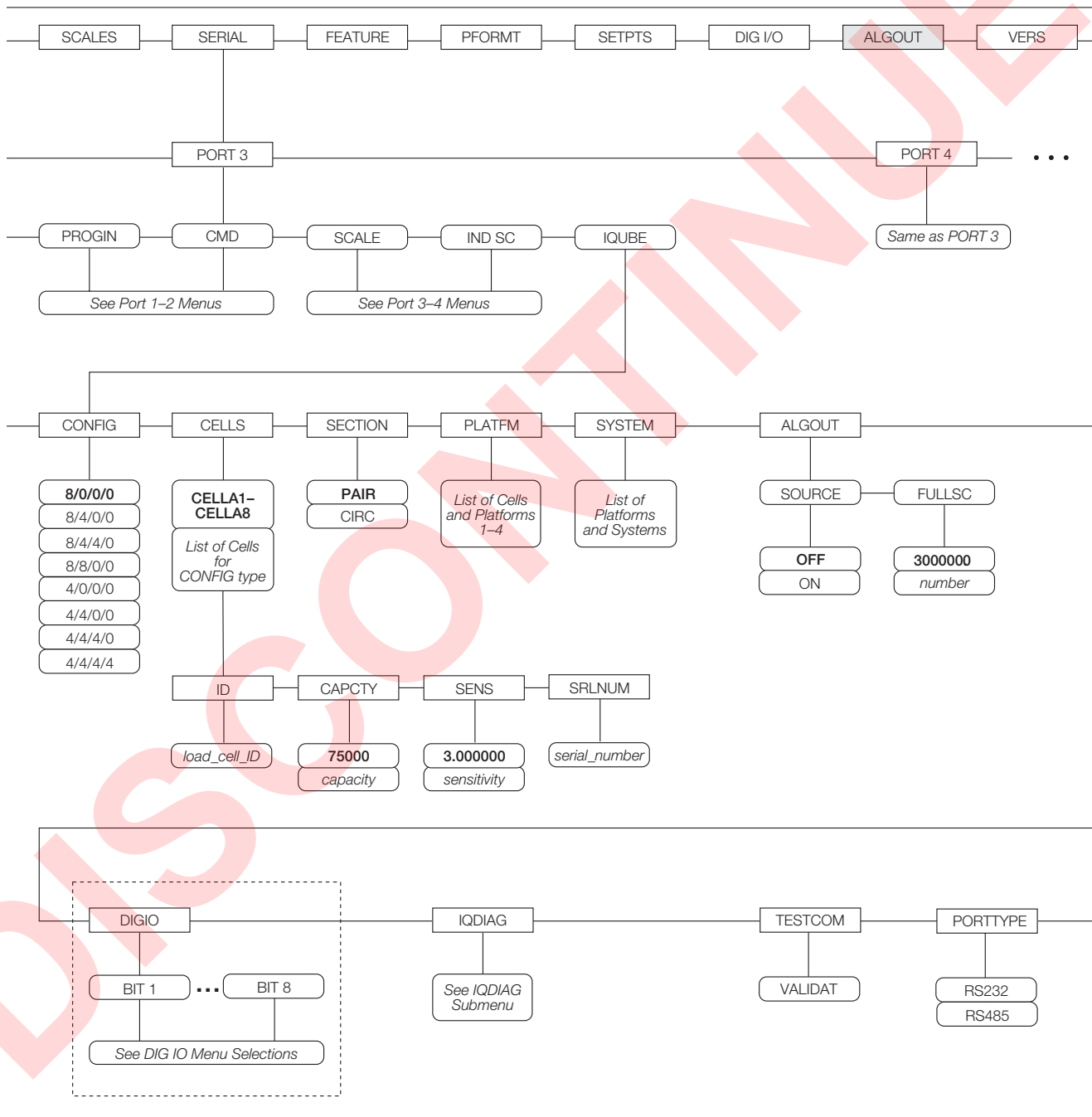

Figure 3-2. SERIAL Menu, iQUBE Submenu

<i>SERIAL Menu (iQUBE Submenu)</i>		
Parameter	Choices	Description
CONFIG	8/0/0/0 8/4/0/0 8/4/4/0 8/8/0/0 4/0/0/0 4/4/0/0 4/4/4/0 4/4/4/4 4/8/0/0	Specifies the <i>iQUBE</i> system configuration.  The first value (8 or 4) designates the number of channels on the <i>iQUBE</i> primary board; the remaining three values represent attached secondary units, if any, and the number of channels on each secondary board.  NOTE: The <i>iQUBE</i> allocates either 4 or 8 channels per board. Total channels cannot exceed 16; an 8-channel board cannot be defined as a 4-channel board.
CELLS	CELLA1–CELLA8 <i>List of cells for CONFIG type</i>	Depending on the value specified for CONFIG, load cells are listed using default names with the format CELLxy, where x is the board identifier (A is the primary unit; B, C, and D are secondary units), and y is a designation (1–4 or 1–8, depending on the number of channels supported by the board), for the individual load cell.  Subparameters allow load cell ID, capacity, sensitivity, and serial number to be specified. See descriptions under <i>Level 4 Submenus</i> .
SECTION	PAIRED CIRCULAR	Specifies whether the load cells defined for the section are referenced to each other as pairs or in a circular relationship. Sections with an odd number of cells must specify CIRCULAR. Full diagnostic capability requires PAIRED section configuration.  See Section 2.3 on page 3 for information about load cell build order.
PLATFM	<i>List of cells and platforms</i>	Use the Add softkey to associate load cells with platforms.
SYSTEM	<i>List of platforms and systems</i>	Use the Add softkey to associate platforms with an <i>iQUBE</i> system. A system can consist of 1–4 platforms.
ALGOUT	SOURCE FULLSC	Specifies the source system and full scale value for an <i>iQUBE</i> analog output. See descriptions under <i>Level 4 Submenus</i> .
DIGIO	BIT 1 – BIT 8	For <i>iQUBE</i> models with digital I/O, specifies the function of each of the digital I/O bits.  See the <i>920i Installation Manual</i> , PN 67887, for information about digital I/O functions.
IQDIAG	ZEROREF CELLBAL LDRIFT PKtoPK CELLEMU MOTBAND	See <i>Level 4 Submenus</i> , Figure 3-3 on page 25, and Table 3-2 on page 26.
TESTCOM	VALIDAT	Select VALIDAT to run a communication validation test for one or more attached <i>iQUBE</i> s. The validation test returns the serial numbers of all attached <i>iQUBE</i> s.
PORTTYPE	RS232 RS485	Specifies the port designation.
<i>Level 4 Submenus</i>		
ID	<i>load_cell_ID</i>	Specifies the load cell ID. Press <b>enter</b> to exit this parameter.
CAPCTY	75000 <i>capacity</i>	Enter the rated load cell capacity.
SENS	3.000000 <i>sensitivity (mV/V)</i>	Enter the actual or nominal load cell millivolt/volt sensitivity.
SRLNUM	<i>serial_number</i>	Optional. Enter the load cell serial number.

Table 3-1. Serial Menu Parameters, *iQUBE* Submenu

<i>SERIAL Menu (iQUBE Submenu)</i>		
<b>Parameter</b>	<b>Choices</b>	<b>Description</b>
SOURCE	OFF <i>system_name</i>	Analog output source. If analog output DAC is installed, assign system name.
FULLSC	300000.0 <i>value (weight)</i>	Analog output full scale range. Specifies the weight value at the full scale analog output (30 mV or 20 mA).
BIT 1 – BIT 8	–	Specifies the function of the digital I/O bit. See the <i>920i Installation Manual</i> , PN 67887, for more information.
ZEROREF	ENABLE THRH %THRH DELAY	Zero reference diagnostic subparameters. See Table 3-2 on page 26. The zero reference test compares the millivolt output of section pairs when half of the load cell outputs are below the specified threshold value.
CELLBAL	ENABLE THRH %TOLR LOAD	Cell balance tolerance diagnostic subparameters. See Table 3-2 on page 26. The cell balance test checks the outputs of section pairs for equal load distribution.
LDRIFT	ENABLE LIMIT %LIMIT TIME LOAD	Load cell drift diagnostic subparameters. See Table 3-2 on page 26.
PKtoPK	ENABLE LIMIT	Peak-to-peak diagnostic subparameters. See Table 3-2 on page 26.
CELLEMU	ENABLE TYPE	Cell emulation. See Table 3-2 on page 26 for more information.
MOTBAND	10.00000 <i>value (weight)</i>	Motion band. See Table 3-2 on page 26 for more information.

*Table 3-1. Serial Menu Parameters, iQUBE Submenu (Continued)*

### 3.4.2 IQUBE Submenu, IQDIAG Parameters

Figure 3-3 shows the IQDIAG parameters on the IQUBE submenu. The IQDIAG parameters allow customization of the *iQUBE*'s diagnostic routines.

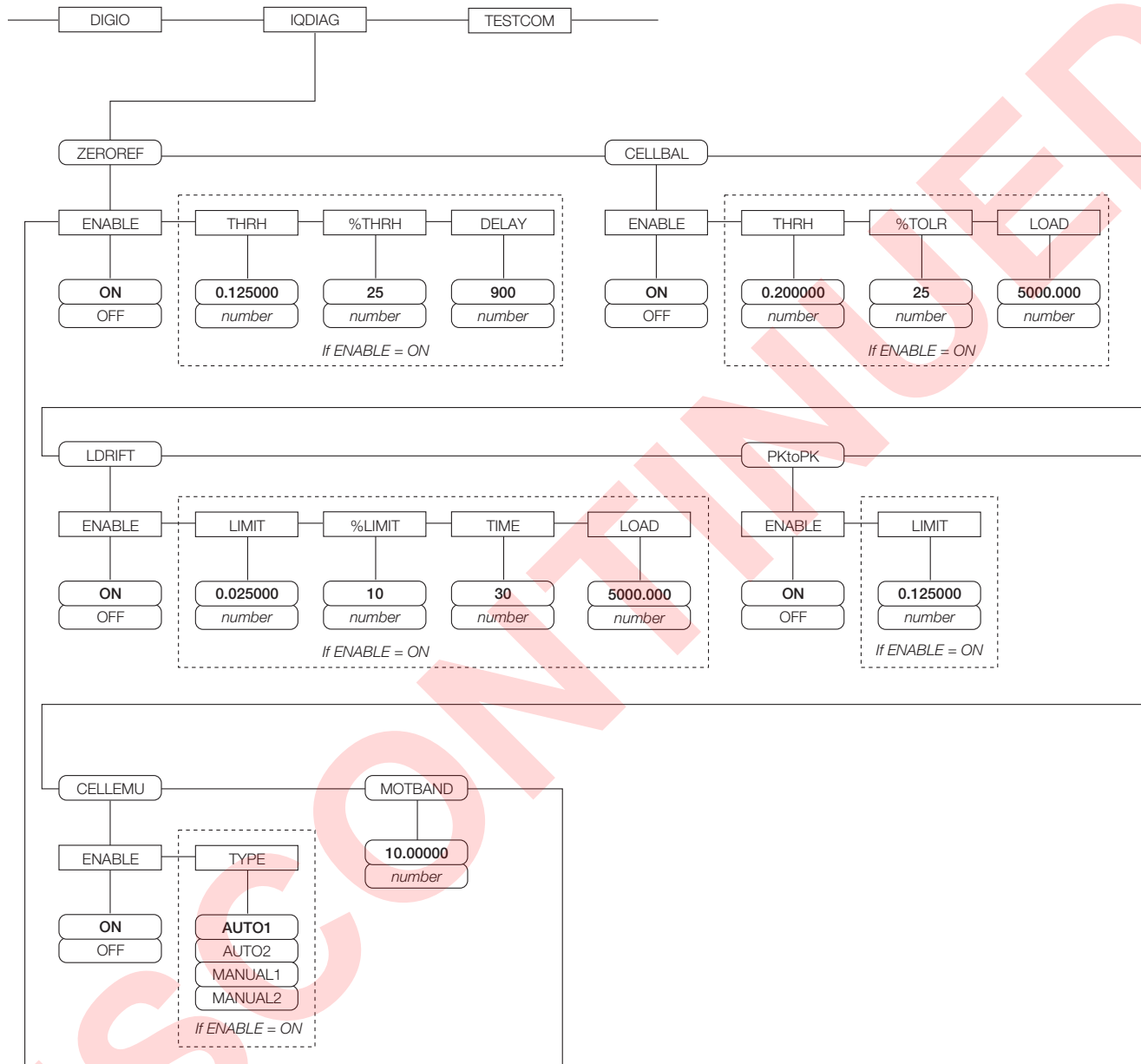

Figure 3-3. IQDIAG Submenu

<i>iQUBE Submenu, IQDIAG Parameters</i>			
Parameter	Subparameter	Choices	Description
IQDIAG	ZEROREF CELLBAL LDRIFT PKtoPK CELLEMU		See descriptions under <i>Level 5 Submenus</i> . Each group of <i>iQUBE</i> diagnostic parameters can be enabled or disabled using the ENABLE subparameter.  See Section 6.0 on page 34 for more information about <i>iQUBE</i> diagnostic tests.
<i>Level 5 Submenus</i>			
ZEROREF	ENABLE	ON OFF	Enable zero reference diagnostics. The zero reference test checks for load cell output errors and inconsistencies when the scale is unloaded. The zero reference test begins when half of the load cells fall below the threshold value. <i>iQUBE</i> determines if any cell is above the threshold value, if any are, after the time delay it looks at that cells cell mates. If it's cell mates fall between calculated zero and percent threshold an error will occur. If any one fo the cell amtes is above the percent threshold, no error will occur.
	THRH	0.125000 <i>value (mV)</i>	A m/v reference value at which a cell is presumed to be unloaded. This m/v threshold value is added to the calculated zero m/v of each cell.
	%THRH	25 <i>value (percent)</i>	Specifies a band above the calculated zero point of each load cell allowed for a presumed zero point.
	DELAY	900 <i>value (seconds)</i>	Time delay in seconds, this is the amount of time a cell must be over the threshold value.
CELLBAL	ENABLE	ON OFF	Enable cell balance diagnostics. The cell balance test checks for balance between cells in a section of a scale. The test will not run until the millivolt threshold of both cells in a section have been met and the load value of the scale has been exceeded. As a cell in a section increases or decreases to meet the percent tolerance an error will be issued.
	THRH	0.200000 <i>value (mV)</i>	A m/v reference value at which the cells have to exceed from the calibration zero before the test starts.
	%TOLR	25 <i>value (percent)</i>	Specifies a weight ratio between the cells in a section that must be met to obtain an error.
	LOAD	5000.000 <i>value (weight)</i>	A weight value that the scale has to exceed before the test will run.

Table 3-2. *iQUBE Submenu, IQDIAG Parameters*

<i>iQUBE Submenu, IQDIAG Parameters</i>			
Parameter	Subparameter	Choices	Description
LDRIFT	ENABLE	ON OFF	Enable loaded drift test diagnostics. Tests for drifting load cell output, which can indicate binding or a deteriorating cell, when the scale is loaded. The test begins after the load value has been exceeded and the scale is considered out of motion (see note.) Once the scale comes to a stable live load, the timer will start. If any one cell is above the limit after the timer expires and any of the remaining cells are below the percent limit, no error will occur. <b>NOTE:</b> If the scale exceeds the motion band in a .5 second interval after a stable weight, the test is reset until it comes out of motion again.
	LIMIT	0.025000 <i>value (mV)</i>	A m/v reference representing drift allowed for cells on a loaded scale.
	%LIMIT	10 <i>value (percent)</i>	Specifies the percentage difference allowed between the millivolt output values of a cell and it's cell mates when the scale is loaded.
	TIME	30 <i>value (seconds)</i>	Time delay in seconds between measurements of load cell values.
	LOAD	5000.000 <i>value (weight)</i>	A weight value that the scale has to be above before the test will run.
PKtoPK	ENABLE	ON OFF	Enable peak-to-peak tolerance diagnostics. A back and forth millivolt output that exceeds the limit value.
	LIMIT	0.125000 <i>value (mV)</i>	Peak-to-peak tolerance noise limit. Specifies a millivolt limit for noise allowed between stored measurements.
CELLEMU	ENABLE	ON OFF	Cell emulation. Specifies whether cell emulation can be used to replace output from a bad load cell.
	TYPE	AUTO1 AUTO2 MANUAL1 MANUAL2	Type 1 selections (AUTO1, MANUAL1) use a cell emulation algorithm designed for truck scales. Type 2 selections (AUTO2, MANUAL2) use an algorithm for hopper and pallet scales. See NOTE below for additional information about using Type 2 selections.  AUTO selections specify that the <i>iQUBE</i> determines when to apply cell emulation, based on diagnostic tests, and automatically applies the selected algorithm to replace the output of a defective cell.  MANUAL selections allow the operator to toggle between actual and emulated load cell outputs by using the <i>920i</i> diagnostic display.  Type 2 selections (AUTO2, MANUAL2) require the "snapshot" function ( <b>Snapshot</b> softkey on the diagnostic display) be executed while the scale is weighing properly. The snapshot provides the weight distribution reference used during cell emulation.
MOTBAND	—	10.00000 <i>value (weight)</i>	Platform motion band. Specifies the amount of weight change allowed in a 0.5-second interval. Diagnostic tests are run only when platform stability is within the specified motion band.

Table 3-2. *iQUBE Submenu, IQDIAG Parameters (Continued)*

### 3.4.3 PFORMT Menu

See the *920i Installation Manual*, PN 67887, for general information about print formats. See Section 7.2 on page 39 for information about the ALERT print format.

**NOTE:** Port 3 is the default port for most print formats. If the *iQUBE* is attached to the *920i* using port 3, ensure that the serial print format is not also routed to port 3. Use the *PORT* parameter to change the print format serial port assignment.

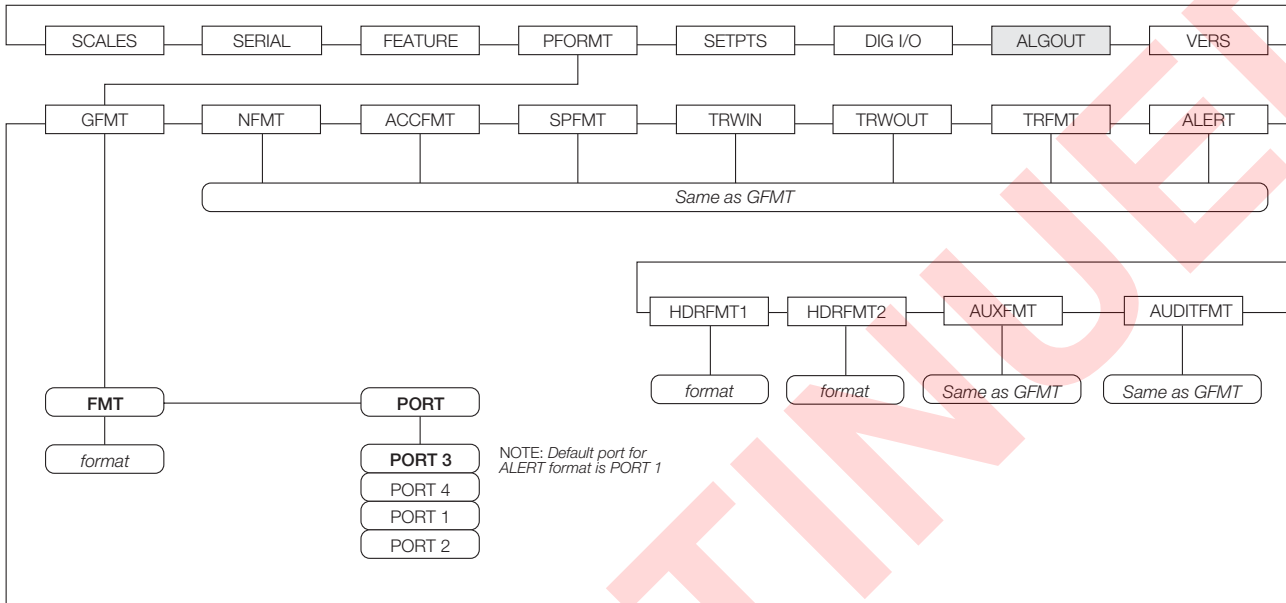

Figure 3-4. PFORMT Menu

## 4.0 PC Configuration

When used with the 920i indicator, the *iQUBE* can be configured using a PC running either the *iRev* or the *Revolution III* program. *iRev* allows complete configuration of the 920i, with the capability to download the *iQUBE* configuration from the indicator to the junction box. *Revolution III* can be used to configure the *iQUBE* directly, for use with any indicator. *iQUBE* configurations created using *Revolution III* can be uploaded to the 920i.

### 4.1 Using Revolution III

The *Revolution III* configuration utility can be used to set *iQUBE* configuration parameters for use with any indicator. When *Revolution III* configuration is complete, configuration data is downloaded to the *iQUBE*.

*Revolution III* supports both uploading and downloading of *iQUBE* configuration data. This capability allows configuration data to be retrieved from one *iQUBE*, edited, then downloaded to another. *Revolution* provides online help for each of its configuration displays.

To use *Revolution III*, do the following:

1. Install *Revolution III* on an IBM-compatible personal computer running Windows® 98 or later. Minimum system requirements include a processor speed of at least 166MHz, 32MB of memory (64MB recommended, required for NT4, 2000, XP), and at least 40MB of available hard disk space for installation.
2. With both the *iQUBE* and the PC powered off, connect the PC serial port to pins 2, 3, and 6 of connector J7 on the *iQUBE* connector board. (See Figure 2-2 on page 4 and Figure 2-4 on page 7).
3. Power up the PC and the *iQUBE*. Use the setup switch to place the *iQUBE* in setup mode.
4. Start the *Revolution III* program.

#### 4.1.1 Revolution III Configuration

To configure the *iQUBE* using *Revolution*, do the following:

1. With the PC and *iQUBE* connected and the *Revolution III* program running, select *New* from the *File* menu.
2. On the *Select Indicator* display, highlight the *iQUBE* icon, for the correct core version, see Figure 2-2 on page 4, click the radio button for *New Configuration File*, then click *OK*. The *iQUBE* Information Display is shown.
3. Select *Configuration* from the left-hand tool bar on the *iQUBE* Information Display (see Figure 4-1). The *Configuration* submenu is shown.



Figure 4-1. Revolution *iQUBE* Display

4. Select **Core**. Use this screen to set the Auto Transmit Port and section type. Note: As you set up *iQUBE* you will be moving down through the configuration menu pages.
5. Select the **Cells Configuration** display. Use this display to select the load cells used in the *iQUBE* system by checking the box to the left of each cell. Enter load cell data such as factory sensitivity, serial numbers, and capacity on the General Information sheet for each cell.
6. Select the **Platforms Configuration** display. Cells that were checked on the Cells screen are now listed as Available Load Cells for the *iQUBE*.
7. Click on **Platform 1**.
8. Double-click on each available load cell to move the cell into the Assigned Load Cell column for Platform 1.  
**NOTE:** You can rearrange the Assigned Cells by clicking on individual cells and then using the up or down arrows to change the position of the cell.  
As cells are added to the Assigned Cell column, a Section Format Diagram is displayed at the bottom of the screen.
9. Select the **Systems** display.
10. Click on **System 1**.
11. Platform 1 is now shown in the Assigned

Platforms field. Click the **Platform 1** box to assign Platform 1 to System 1. Use the General display to enter scale system parameters.

#### 4.1.2 Downloading to the iQUBE

Once configuration is complete, you must download the configuration data from the PC to the *iQUBE*.

1. Go to the Communications menu and select *Connect...* Revolution automatically detects the *iQUBE* communications port.
2. Return to the Communications menu and select *Download Configuration*. Click **Begin** to initiate the download. Downloading may take up to 30 seconds.

## 4.2 Using iRev

The *iRev* utility provides a suite of functions used to support configuration, calibration, customization, and backup of the *920i* software. Hardware and software configuration, *920i* display setup for up to ten screen designs, stream and ticket formatting, setpoint configuration, database management, and *iRite* program editing are all supported by *iRev*.

Calibration values, scale, setpoint, and display configuration, database tables, and user programs, can be both saved and restored to the *920i* using *iRev*. Other supporting applications provided with *iRev* include:

- The *iRev* Editor provides a basic editor and a compiler for writing *iRite* applications.
- The Rice Lake Web Update utility uses your internet connection to check for and download updates to the *iRev* and *920i* software.
- The *iLaunch* utility can be installed to display a set of icons used for convenient startup of *iRev* and its supporting applications, including the Help system.

#### Hardware and Software Requirements

Minimum system requirements: 166 MHz, x86-compatible, with 32MB RAM (64MB for NT4/2000), 40MB disk space. Recommended system: 233 MHz, x86-compatible or greater, with 64MB RAM, 40 MB disk space.

*iRev* runs on most Windows® operating systems, including Windows 95 (original release), Windows 95 OSR2, Windows 98, Windows 98 SE, Windows ME, Windows NT 4.0 (SP4 or greater), Windows 2000, and Windows XP (Home or Professional).

When used with the original release of Windows 95, *iRev* requires an updated version of TAPI. The TAPI update is included on the *iRev* installation CD and is available from the RLWS web site at [www.rlws.com](http://www.rlws.com).

Internet Explorer® (IE) 4.0 or greater is required to use the *iRev* help system. Explorer is included on the *iRev* installation CD or is available from Microsoft Corporation.

*iRev* is installed using a standard Windows installation procedure. *iRev* applications and support files are installed in a directory named *iRev*; icons for the *iRev* application, the *iRev* Editor, Uninstall, and the Rice Lake Web Update utility are placed in the Windows Start menu.

See the *920i Installation Manual* for more information about using *iRev*.

#### iRev Configuration

Configuration of the *iQUBE* using the *iRev* program is similar to using the *920i* menus. Use the **Tools** toolbar selection to configure the serial port used for the *iQUBE* connection.

Figure 4-2 shows one of the *iRev* serial port configuration displays.

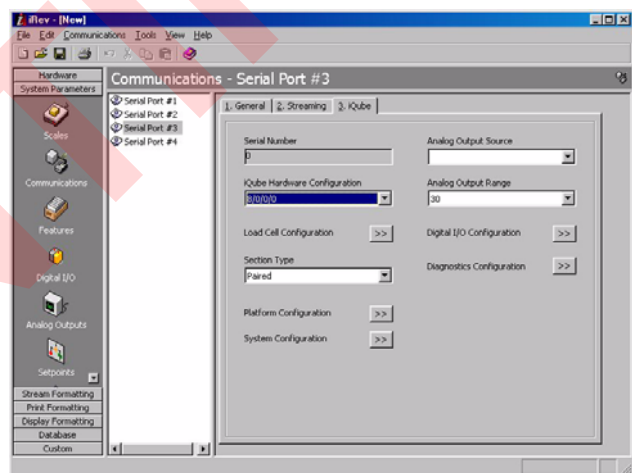

Figure 4-2. *iRev* Serial Port Configuration Display

Once *iRev* configuration of the *920i* is complete, use the *Download Configuration* function on the *iRev* Communications menu to download the configuration to the indicator.

To download the *920i* configuration to the *iQUBE*, use the **Download** softkey on the *920i* serial port *iQUBE* CONFIG menu. Use the **up** and **down** keys to select *Download iQUBE configuration only*, then press **enter**.

At version 2.05 and higher, the *920i* download to *iQUBE* is done automatically after the *iRev* download.

## 5.0 Calibration

The *iQUBE* can be calibrated using the *920i* front panel or *Revolution III*. The following sections describe the calibration procedure for each of the calibration methods.

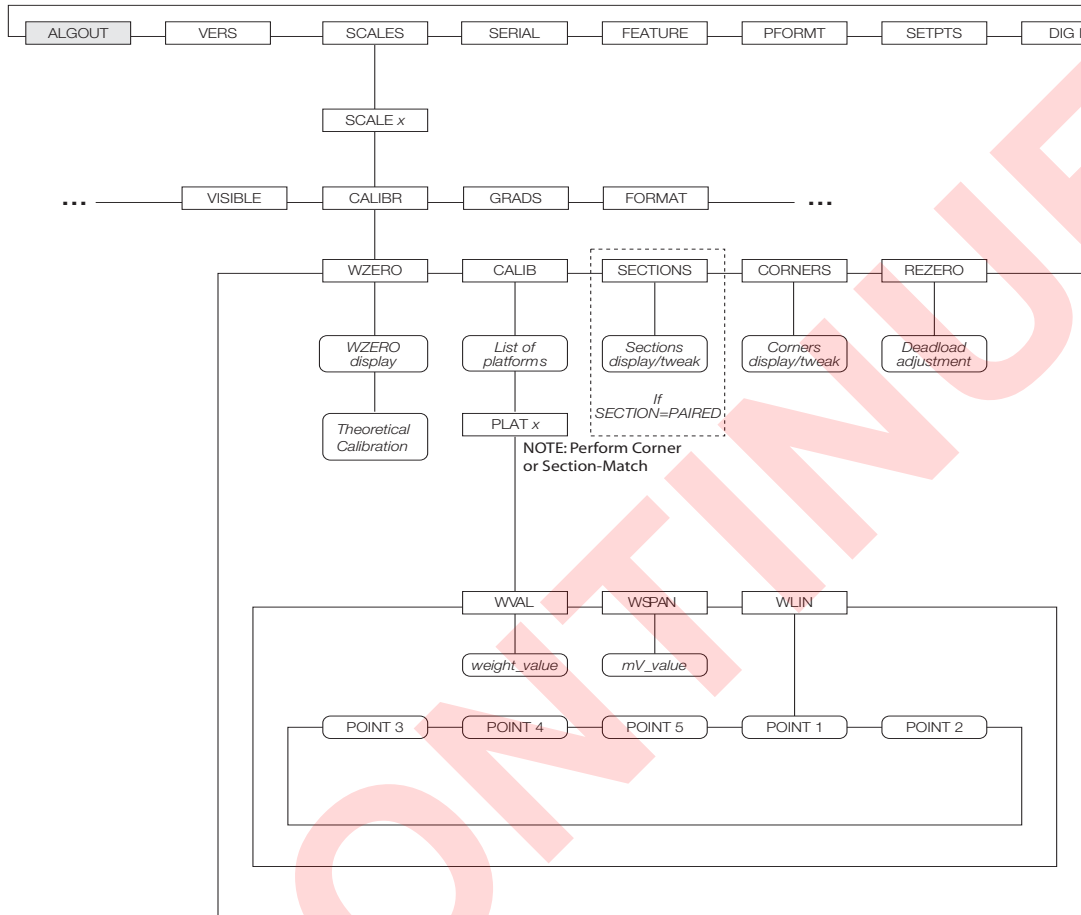

Figure 5-1. CALIBR Submenu

### 5.1 920i Front Panel Calibration

The CALIBR submenu (under the SCALES menu, see Figure 5-1) is used to calibrate the *920i* and the *iQUBE* at the same time.

Three calibration methods can be used to trim the load cells:

- Theoretical
- Cal-Match
- Manual trimming

#### 5.1.1 Theoretical Calibration

To perform a theoretical calibration of the *iQUBE* using the *920i* front panel, press the **Theoretical Calibration** softkey. The dead load value is captured and the cells trimmed based on the capacity and sensitivity values entered for the cells. Scale capacity is set at the total of the load cell capacities.

#### 5.1.2 Cal-Match Calibration

To perform a Cal-Match calibration of the *iQUBE* using the *920i* front panel, do the following:

1. Place the indicator in setup mode (display reads *Scale Configuration*) and remove all weight from the scale platform.
2. With the SCALES menu highlighted, press the down key to show the CALIBR parameter.
3. From the CALIBR parameter, press down again to show a list of configured platforms and select the platform to be calibrated.
4. Press down to go to the test weight parameter (WWAL). By default, the test weight value is set to the total load cell capacity. Use the numeric keypad to enter the test weight, then press enter.
5. Press the Cal-Match softkey to continue

calibration. **NOTE:** Cal-Match calibration can be canceled by pressing the CLEAR key.

6. Ensure scale is empty, then use the up and down keys to select **Corner Cal-Match** (see Figure 5-2) or **Section Cal-Match**. Press enter. The *iQUBE* calculates the zero reference point.

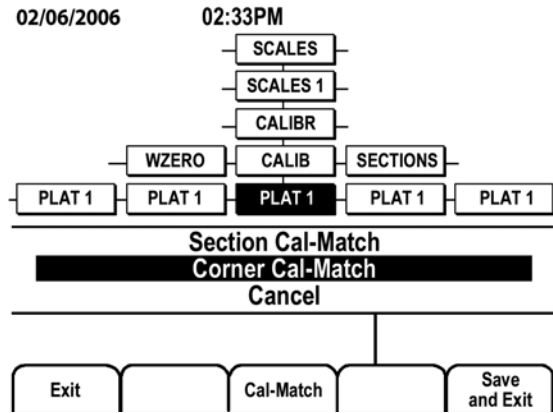

Figure 5-2. 920i Cal-Match Selection

7. The display now prompts *Cal-Match Point 1*. Place a test weight over the cell or section to be tested, then press enter. **NOTE:** It is not necessary to measure the cells in any particular order.
8. Once the *iQUBE* has read the cell, the 920i display will show *Cal-Match Point 2*. Move the test weight to the next cell or section and press enter. Repeat until all cells have been measured.
9. When the last cell has been measured, the *iQUBE* automatically sets the load cell trim factors. The 920i display shows *Calibration Complete*.
10. Press up to return to the SCALES menu, or press the **Save and Exit** softkey to exit setup mode.

**NOTE:** Cal-Match calibration can be performed using a vehicle as the test weight, but a smaller footprint and heavier weight value will yield better results. Mechanical characteristics of the scale may prevent Cal-Match from automatically computing load cell trim factors.

### 5.1.3 Manual Trim Factor Adjustment (Tweaking)

Section or corner trim factors can be manually tweaked. When using the *iQUBE* with a 920i indicator, use the up or down navigation key to select the section or corner to be adjusted, then use the **Tweak -** or **Tweak +** softkey to adjust the value. The displayed weight for the scale system is shown at the bottom of the weight column.

Tweaking can be performed following a Cal-Match calibration or when replacing a load cell.

### 5.1.4 Final Calibration

The span and linear calibration displays provide a **Calibration** softkey to perform a traditional calibration for the selected point. Enter the weight value under **WVAL**, then press the **Calibration** softkey under **WSPAN** for each platform. Continue under **WLIN** for systems using linear calibration.

Trim factors displayed for sections or corners can be manually tweaked up or down. The cell with the lowest output is given a trim factor of 1.0000.

## 5.2 Revolution III Calibration

### Cal-Match Calibration

With the *iQUBE* connected to a PC running the *Revolution III* program, do the following:

1. From the Interactive menu, select *Cal-Match Load Cell Matching...* (see Figure 5-3).

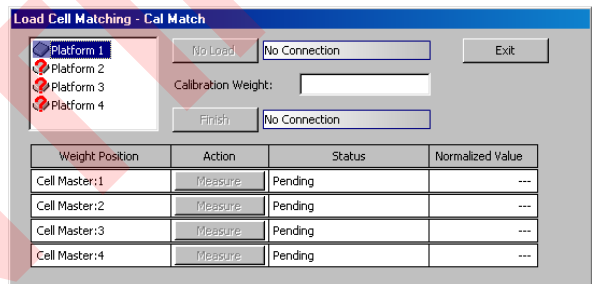

Figure 5-3. Cal-Match Load Cell Matching Display

2. Remove all weight from the scale platform. Click on **No Load**. The word *Transmitting* is displayed while the no-load values are calculated. This process can last up to 45 seconds.
3. Enter the test weight value in the *Calibration Weight* field. You are now ready to measure the load cell outputs using the Cal-Match procedure.
4. Place the test weight over the cell to be measured. It is not necessary to measure the cells in any particular order.
5. Click the first **Measure** box. As each cell is completed the next cell becomes available for measurement.
6. Repeat steps 4 and 5 until all cells have been measured.
7. Click **Finish**. Cal-Match automatically calculates the load cell trim factors. These normalized sensitivity values are displayed for each cell in the platform.
8. Click **Exit**.

*iQUBE* calibration is complete. You can view the active status of the cells, platform, or system by returning to the Interactive menu and selecting *Status Monitoring* for cells, platforms, or systems. Click on the **Auto Refresh** box to automatically update the readings from the *iQUBE*.

DISCONTINUED

# 6.0 Diagnostics

## 6.1 iQUBE Diagnostic

The *iQUBE* connector board provides bi-color cell status LEDs (see Figure 2-2 on page 4) that indicate the status of connected load cells. Table 6-1 lists the cell status indications shown by the LEDs.

LED Color	meaning
Green	Load cell good
Red	Load cell error
Off	Disabled/no load cell connected

Table 6-1. LED Status Indications

## 6.2 Cell Mate Relationships

Cell mates to a specific load cell are defined as the load cells that are horizontally or vertically adjacent to each other. In the platform illustration below LC2 and LC 3 are cell mates to LC1 and LC2, LC3, and LC6 are cell mates to LC4.

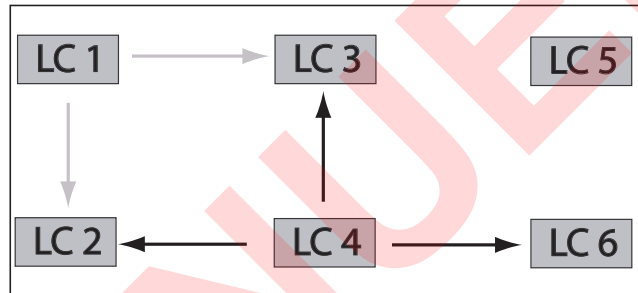

Figure 6-1. Cell Mate Indications

## 6.3 Diagnostic Tests

The *iQUBE* provides a number of diagnostic tests, including boundary, weighing, and system tests (see Table 6-4 on page 37 for a list of diagnostic error messages). The table below describes the tests that can be enabled or disabled in the diagnostics of the *iQUBE*.

Test	Definition	Description	920i Default	Revolution III/ iQUBE Default
Zero Reference	Which cell is out of tolerance at zero	threshold: the upper limit of the zero reading of the cells.	0.125mv	0.200mv
		Per Cent threshold: the percentage of zero reading of adjacent cells.	25%	20%
		Delay: time to wait until the next testing process.	900 seconds	900 seconds
Cell Balance	Which cell is out of balance with its section cell mate when weight is on the scale.	Threshold	0.200mv	200mv
		Per Cent tolerance	25%	20%
		Load: minimum load needed to initiate the test	5000lb	5000lb
Load Cell Drift	Checks for load cell outputs that have changed over time with load applied..	Limit	0.025mv	0.025mv
		Per Cent limit	10%	10%
		Time	30 seconds	30 seconds
		Load: minimum load needed to initiate the test	1000lb	1000lb
Peak to Peak Limit	Check for noisy load cell output not attributed to environmental conditions.	Limit	0.125mv	0.250mv
Motion Band	Defined value in Grads that defines a scale not in motion	Motion band range: should be the same as MOTBAND for truck scale	10lb	10lb
Cell Emulation	Process of inputting a value based on the matrix offset values gatered at Calmatch time.	Type 1 (standard truck scale): Auto 1, Manual 1 Type 2 (hopper scale configuration): Auto 1, Manual 2	Off	Off

Table 6-2. iQUBE Diagnostic Settings

## Diagnostic Test Examples

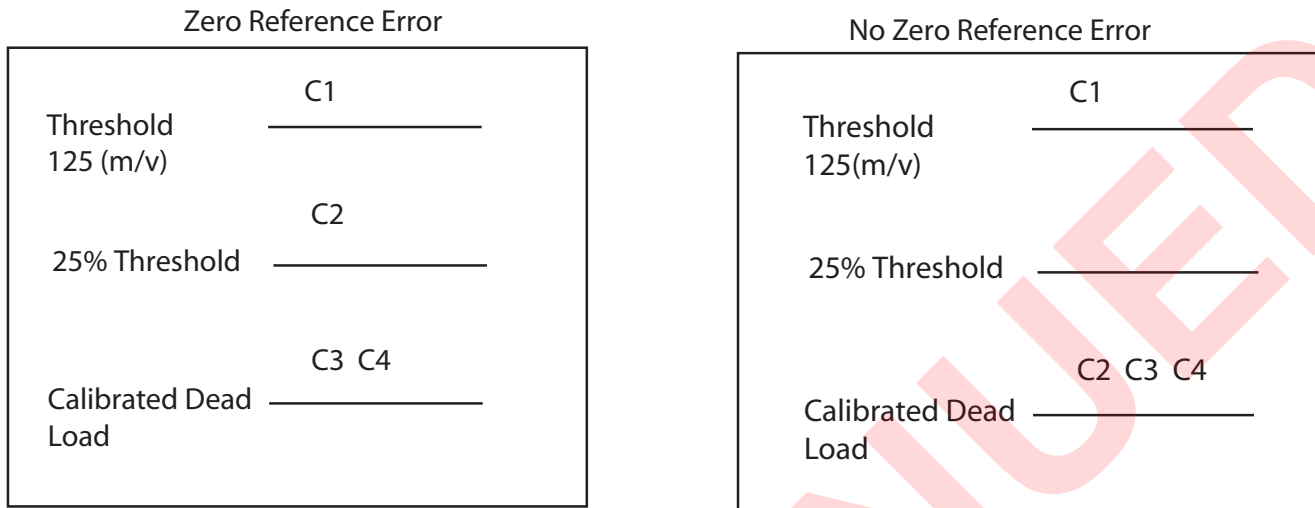

Figure 6-2. Zero and No Zero Reference Errors

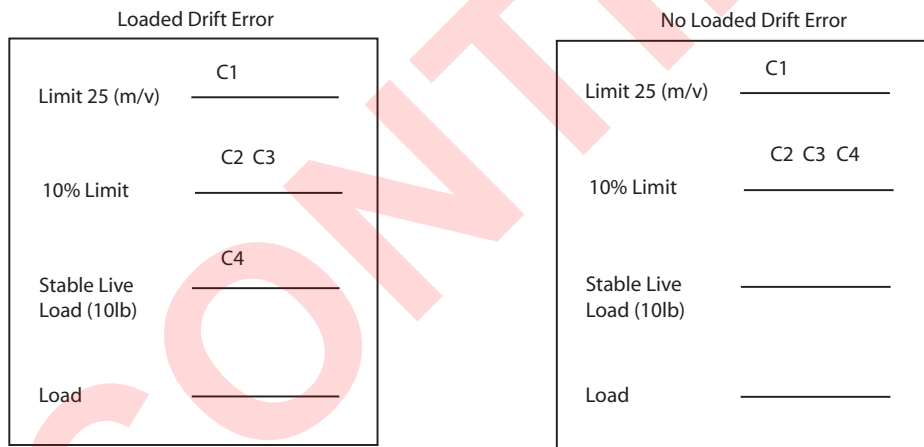

Figure 6-3. Loaded Drift and No Loaded Drift Error

25%	C1 = 250 lbs C2 = 1000 lbs
50%	C1 = 500 lbs C2 = 1000 lbs
75%	C1 = 750 lbs C2 = 1000 lbs

### NOTES:

- the higher the %TOLR, the less variance needed to obtain error
- The lower the %TOLR, the more variance needed to obtain error
- Multiple sections can error at the same time

Figure 6-4. Cell Balance Error

## 6.4 Diagnostic Setup

Parameters associated with each of the *iQUBE*'s diagnostic tests can be set using the *920i* menus, *iRev*, or *Revolution III*. See Section 3.4.2 on page 25 for descriptions of the *iQUBE* diagnostic parameters for the *920i*.

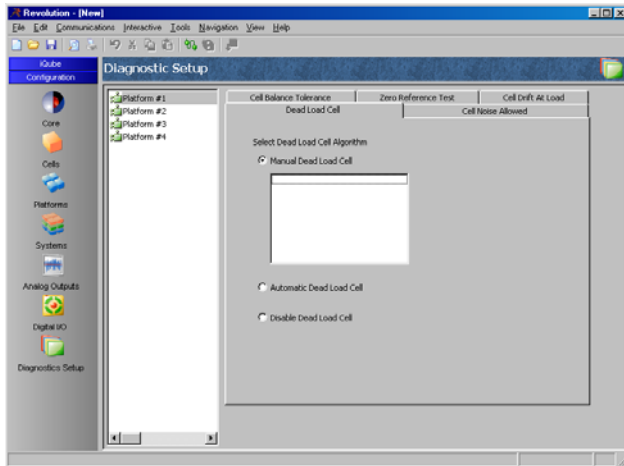

Figure 6-5. Revolution III Diagnostic Setup Display

### 6.4.1 Configuring the 920i Diagnostics Softkey

When using the *iQUBE* with the *920i* indicator, a **Diagnostics** softkey can be configured to display diagnostic information when in weigh mode. Use the **FEATURE** menu, **SOFTKEYS** submenu, to select the Diagnostics softkey (see Figure 6-6).

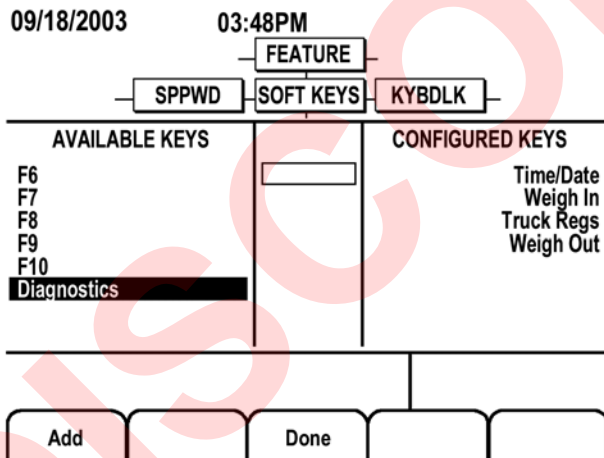

Figure 6-6. Selecting Diagnostics Softkey

### 6.4.2 920i Diagnostic Display

Figure 6-7 shows an example of a *920i* display of *iQUBE* diagnostic information. Information shown includes the following:

- Cell name
- Cell deadload value (mV)
- Current individual cell and total values (mV)

- Number of weighments
- Cell status for highlighted cell. Use the indicator navigation keys to select cells.

**NOTE:** Displayed deadload and current values are raw millivolt values. All diagnostic measurements use corrected mV values:

$$\text{corrected\_value} = \text{current\_value} - \text{deadload\_value}$$

02/06/2006 02:33PM SCALE #1

**Diagnostics**

NAME	DEADLOAD	CURRENT
A2-Load Cell 2	0.1871	0.2159
A3-Load Cell 3	1.1509	0.0547
A4-Load Cell 4	0.7567	0.7301
A5-Load Cell 5	0.3791	0.3583
A6-Load Cell 6	0.0931	0.1565
A7-Load Cell 7	0.7079	0.6655
<b>System 1</b>		<b>17.24608</b>
<b>44 weighments over 1000 grads</b>		

Cell OK

Previous Done Cell Emulation Next

Figure 6-7. 920i Diagnostic Display

The *920i* diagnostic display can be shown by pressing the **Diagnostics** softkey (if configured).

In setup mode, diagnostic information can be shown by going to the **VERS** menu., pressing the **Contact** softkey, then the **Next** softkey.

Access through the **VERS** menu also displays softkeys for **Clear Diagnostics** and, if cell emulation is enabled, **Cell Emulation**. If cell emulation is set to **AUTO2** or **MANUAL2** (see page 27), a **Snapshot** softkey is also shown.

## 6.5 Error Messages

Table 6-3 shows the alert system status messages generated by the *iQUBE*.

Scale Number	Status Message	Cell Error Messages	Cell ID
Scale x	System boundary error: Weighing error: Master error:	Error 1 Cell Error 2 Cell Error 3 Cell	A <sub>n</sub> ,B <sub>n</sub> ,C <sub>n</sub> ,D <sub>n</sub>

Table 6-3. Alert Error Message Format

Error messages are displayed on the indicator and can be used by print formats and *iRite* user programs.

Table 6-4 lists the system and cell error messages.

System Error Message	Cell Error Message	Error Categories
Boundary Error	Error 1	Cell Not Detected
		AtoD Not Responding
		Cell At Rail
		Cell Over/Under Range
Weighing Error	Error 2	Cell Long Term Drift Error
		Cell Balance Error
		Cell Noise Error
		Cell At Load Drift Error
		Zero Reference Cell Error
Master (Primary Unit) Error	Error 3	Slave (Secondary) Comm Error
		Temperature Error
		Low Excitation Voltage
		High Excitation Voltage
		Low Power Supply
		High Power Supply
		DtoA1 Calibration Error
		DtoA2 Calibration Error

Table 6-4. System and Cell Error Messages

### 920i Diagnostic Display Error Codes

Table 6-5 lists error codes that may be shown in the status area of the 920i diagnostic display. Error codes are shown in the format *Cell Error X*, where *X* is the code listed below. If the cell is reporting no error, the message *Cell OK* is shown.

920i Error Code	Error Category
A	A-to-D not responding
B	Cell balance error
D	Load drift error
M	Cell not detected
N	Cell noise error
O	Cell over/under range error
R	Cell railed error
Z	Zero reference drift error

Table 6-5. 920i Diagnostic Display Error Codes

## 7.0 Alerts

When attached to the *920i* indicator, diagnostic error messages generated by the *iQUBE* are shown on the indicator display. The *920i* alert support also allows messages to be printed or, if the *920i* is equipped with an Ethernet card attached to a network, routed via e-mail to an alert contact.

### 7.1 Network Alert Notification

Figure 7-1 shows an example of a system configured to relay *iQUBE* alert messages through e-mail. The *920i* indicator is equipped with an Ethernet card. The *920i* and Ethernet card configurations must include the following:

- In the Ethernet card configuration, *Connect Mode Settings*, the *Startup* value must be set to *Manual Connection (C4)*. This allows the *920i* to set the address of the SMTP (Simple Mail Transfer Protocol) server used by the Ethernet card.
- Set the Inactivity Timeout to ENABLE
- Set the Inactivity Timer to 0:15
- The *SMTP server address* must be set in the *920i*. This value can be set in *iRev* or by using the ALERT.SERV serial command. The SMTP server address cannot be set using the *920i* menus. To disable alert notification, set the SMTP server address to 0.0.0.0.
- The *alert contact e-mail address* must be set to a valid address. This value can be set using the *920i* menus (FEATURE menu, CONTACT submenu, EMAIL parameter), through *iRev*, or by using the CONTACT.EMAIL serial command.
- The *920i alert port* must be set to the port used by the Ethernet card. This value can be set in *iRev* or by using the ALERT.PORT serial command.

The body of the e-mail message sent to the alert contact consists of the alert format configured in the *920i* (see Section 7.2 on page 39).

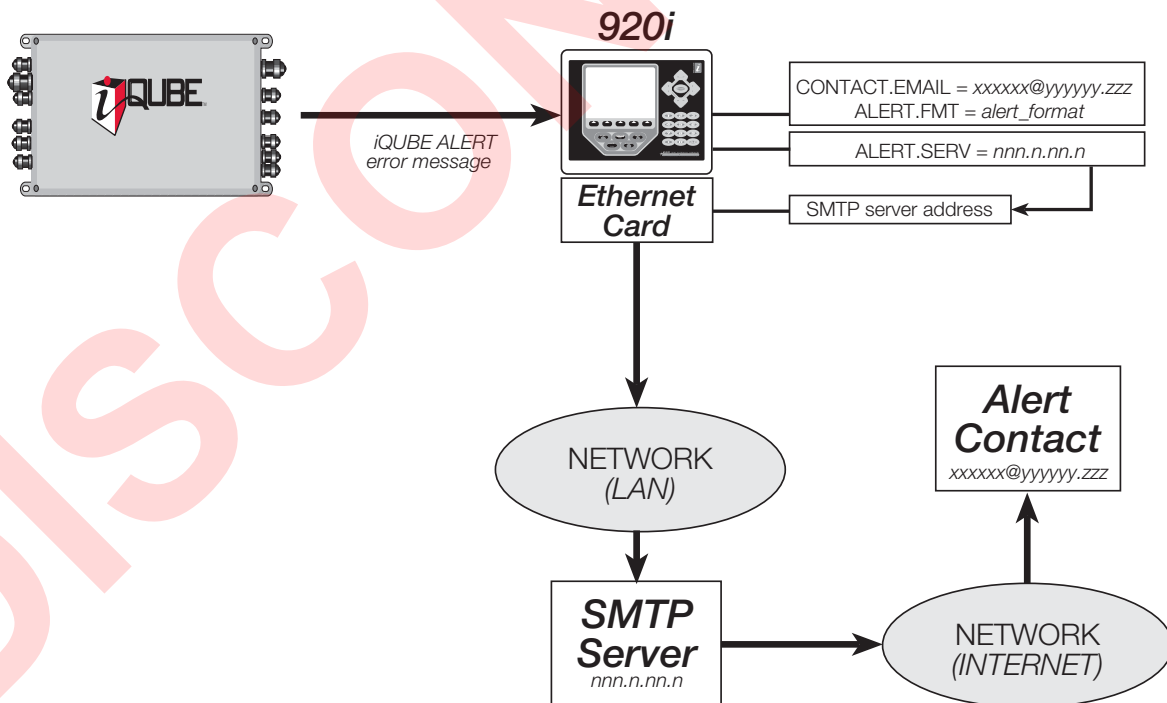

Figure 7-1. *iQUBE* Alert Notification Process

**NOTE:** After the SMTP address has been set to other than 0.0.0.0 (in the *920i*) normal uploading/downloading with *iRev* (in TCP/IP mode) is *not* allowed and Telnet will *not* operate in bi-directional fashion.

## 7.2 Alert Format

The default 920i alert print format is as follows:

```
<COMP><NL>
<COAR1><NL>
<COAR2><NL>
<COAR3><NL>
<CONM1><NL>
<COPH1><NL>
<CONM2><NL>
<COPH2><NL>
<CONM3><NL>
<COPH3><NL>
<COML><NL>
<ERR><NL>
```

Commands used in the 920i alert format are listed in Table 7-1.

Command	Content
<COMP>	Company name (up to 30 characters)
<COAR1> <COAR2> <COAR3>	Contact company address, lines 1–3 (up to 30 characters)
<CONM1> <CONM2> <CONM3>	Contact names (up to 20 characters)
<COPH1> <COPH2> <COPH3>	Contact phone numbers (up to 20 characters)
<COML>	Contact e-mail address (up to 30 characters)
<ERR>	Alert error message (system-generated)
<NL $nn$ >	New line ( $nn$ = number of termination (<CR/LF> or <CR>) characters). If $nn$ is not specified, 1 is assumed. Value must be in the range 1–99.

Table 7-1. Alert Format Commands

Values for the contact information referenced by the print formatting commands shown in Table 7-1 can be set using the 920i menus (FEATURE menu, CONTACT submenu), serial commands (see Section 8.0 on page 42), or the *iRev* configuration utility.

See the *920i Installation Manual*, PN 67887, for more information about print formatting.

## 7.3 FEATURE Menu, CONTACT Submenu

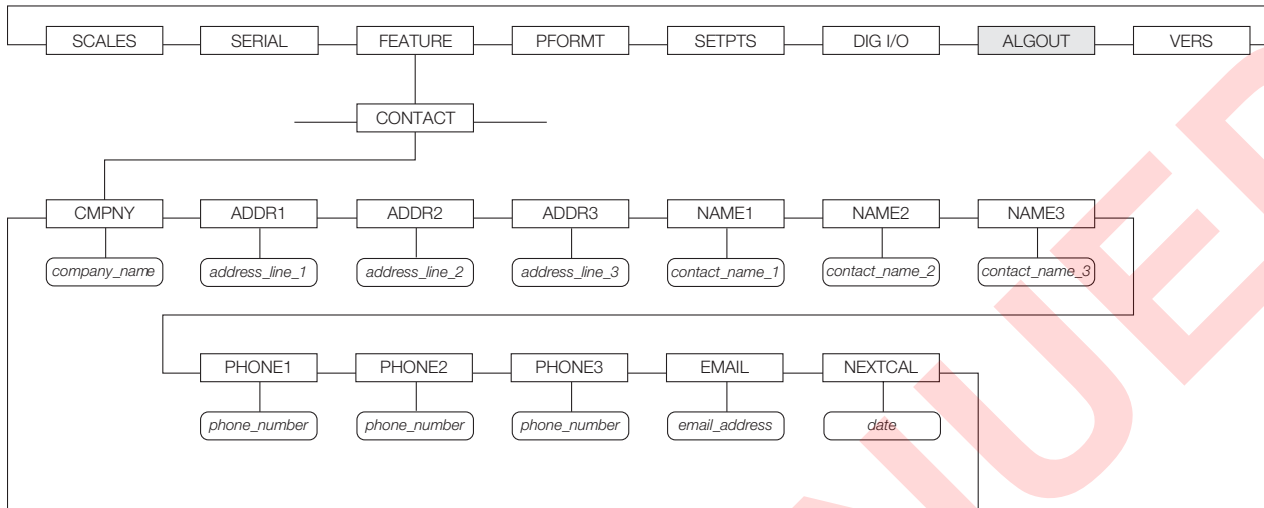

Figure 7-2. CONTACT Submenu

FEATURE Menu, CONTACT Submenu		
Parameter	Choices	Description
<b>Level 3, CONTACT submenu</b>		
CMPNY	<i>company_name</i>	Enter the name of the contact company or dealer.
ADDR1– ADDR3	<i>address</i>	Enter up to three lines of address information for the contact company.
NAME1– NAME3	<i>contact_name</i>	Enter names of up to three contact persons.
PHONE1– PHONE3	<i>phone_number</i>	Enter phone numbers for each of the contact persons specified for the NAME <sub>x</sub> parameter.
EMAIL	<i>email_address</i>	Enter the email address of the contact company or dealer. If the <i>iQUBE</i> alert support is used to send automated alert messages (see Section 7.0 on page 38), enter the email address to which the alert messages will be sent.
NEXTCAL	<i>date</i>	Enter the next scheduled calibration date using the month/day/year format on the DATEFMT parameter. Separator characters are not required.

Table 7-2. CONTACT Submenu Parameters

## 7.4 PFORMT Menu

See the *920i Installation Manual*, PN 67887, for general information about print formats. See Section 7.2 on page 39 for information about the ALERT print format.

**NOTE:** Port 3 is the default port for most print formats. If the *iQUBE* is attached to the *920i* using port 3, ensure that the serial print format is not also routed to port 3. Use the *PORT* parameter to change the print format serial port assignment.

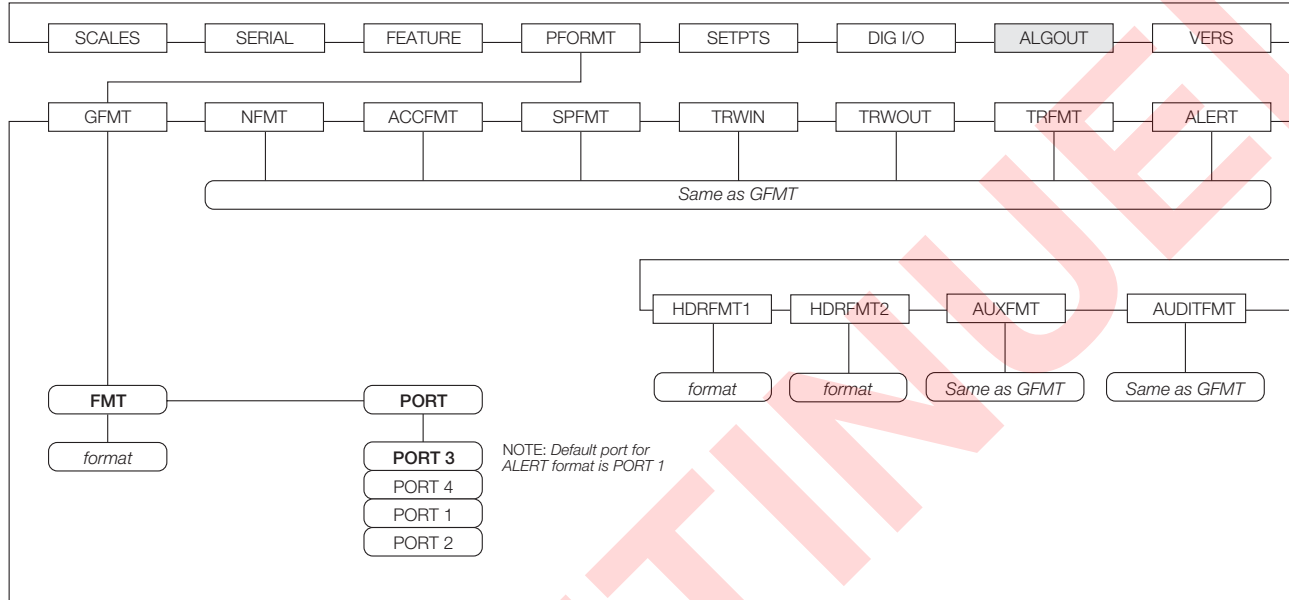

Figure 7-3. PFORMT Menu

## 8.0 920i Serial Commands

The following section lists 920i serial commands used to configure and control the *iQUBE*. See the *920i Installation Manual*, PN 67887, for more information about using serial commands.

Command	Description	Values
SJ.SERIAL_NUMBER# <i>n</i>	<i>iQUBE</i> serial number	<i>Read-only output</i>
SJ.CONFIG# <i>n</i>	<i>iQUBE</i> primary-secondary configuration	8/0/0/0, 4/0/0/0, 4/8/0/0, 4/4/0/0, 4/4/4/0, 4/4/4/4, 8/4/0/0, 8/4/4/0, 8/8/0/0
SJ.SECT_TYPE# <i>n</i>	Section type	PAIRED, CIRCULAR
SJ.VERSION.s# <i>n</i>	System version	<i>Read-only output.</i> s is the system number, n is the 920i serial port number.
SJ.DUMP# <i>n</i>	Dump diagnostic parameters	<i>Read-only output.</i> Dumps all SJ parameters for the <i>iQUBE</i> connected to port n.
SJ.DOWNLOAD# <i>n</i>	Download to <i>iQUBE</i>	Downloads configuration and resets <i>iQUBE</i>

n is the 920i serial port number to which the *iQUBE* is connected.

Table 8-1. 920i *iQUBE* Serial Commands

Command	Description	Values
SJ.LC.ID.c# <i>n</i>	Load cell ID	Load Cell A1, <i>load_cell_ID</i> (24 characters, maximum)
SJ.LC.SRLNUM.c# <i>n</i>	Load cell serial number	(16 characters, maximum)
SJ.LC.CAPCTY.c# <i>n</i>	Load cell capacity	1-500000
SJ.LC.SENS.c# <i>n</i>	Load cell sensitivity	0.0001-9.9999 (mV/V)
SJ.LC.TRIM.c# <i>n</i>	Load cell trim factor	0.0001-9.9999
SJ.LC.ZERO.c# <i>n</i>	Load cell zero value	-0.5 to 45.0

For load cell (SJ.LC.) commands ending with "c#n", c is the load cell number, n is the 920i serial port number.

Table 8-2. 920i *iQUBE* Load Cell Serial Commands

Command	Description	Values
SJ.PLAT.NAME.p# <i>n</i>	Platform name	Platform1, <i>platform_name</i> (24 characters, maximum)
SJ.PLAT.CELLS.p# <i>n</i>	Platform load cells	0,0,0,0,0,0,0,0,0,0,0,0,0,0,0,0 (specify comma-separated list of load cell numbers associated with this platform) or NONE (to clear load cell list)
SJ.PLAT.SIM.p# <i>n</i>	Platform simulated cell	0, 1-16
SJ.PLAT.WVAL.p# <i>n</i>	Platform test weight value	0.0-9999999.0
SJ.PLAT.WSPAN.p# <i>n</i>	Platform span calibration	-0.5 to 512.0
SJ.PLAT.WLIN.V1.p# <i>n</i> - SJ.PLAT.WLIN.V5.p# <i>n</i>	Platform test weight value for linearization points 1-5	0.0-9999999.0
SJ.PLAT.WLIN.F1.p# <i>n</i> - SJ.PLAT.WLIN.F5.p# <i>n</i>	Actual raw count value for platform linearization points 1-5	-0.5 to 512.0
SJ.PLAT.CALTYPE.p# <i>n</i>	Platform calibration type	NONE, FACTORY, CALMATCH, SECMATCH
SJ.PLAT.CALMULT.p# <i>n</i>	Retrieve platform calibration data	—

For platform (SJ.PLAT.) commands ending with "p#n", p is the platform number, n is the 920i serial port number.

Table 8-3. 920i *iQUBE* Platform Serial Commands

Command	Description	Values
SJ.SYS.NAME.s#n	System name	System1, system_name (24 characters, maximum)
SJ.SYS.PLATS.s#n	System platforms	0,0,0,0 (specify platform numbers, 1–4, assigned to sytem) or NONE (to clear platform list)
For system (SJ.SYS.) commands ending with “s#n”, s is the system number, n is the 920i serial port number.		

Table 8-4. 920i iQUBE System Serial Commands

Command	Description	Values
SJ.DIAG.ZEROREF#n	Zero reference diagnostic enable	ON, OFF
SJ.DIAG.ZR.THRH#n	Zero reference threshold	0.0–9.999999
SJ.DIAG.ZR.%THRH#n	Zero reference percent threshold	0–100
SJ.DIAG.ZR.DELAY#n	Zero reference delay	0–65535
SJ.DIAG.CELLBAL#n	Cell balance diagnostic enable	ON, OFF
SJ.DIAG.CB.THRH#n	Cell balance threshold	0.0–9.999999
SJ.DIAG.CB.%TOLR#n	Cell balance percent tolerance	0–100
SJ.DIAG.CB.LOAD#n	Cell balance load	0.0–9999999.0
SJ.DIAG.LDRIFT#n	Load cell drift diagnostic enable	ON, OFF
SJ.DIAG.LD.LIMIT#n	Load cell drift limit	0.0–9.999999
SJ.DIAG.LD.%LIMIT#n	Load cell drift percent limit	0–100
SJ.DIAG.LD.TIME#n	Load cell drift time	0–65535
SJ.DIAG.LD.LOAD#n	Load cell drift load	0.0–9999999.0
SJ.DIAG.PKTOPK#n	Peak-to-peak diagnostic enable	ON, OFF
SJ.DIAG.PK.LIMIT#n	Peak-to-peak limit	0.0–9.999999
SJ.DIAG.CELLEMU#n	Cell emulation enable	ON, OFF
SJ.DIAG.CE.TYPE#n	Cell emulation type	AUTO1, AUTO2, MANUAL1, MANUAL2
SJ.DIAG.MOTBAND#n	Motion band	0.0–9999999.0
For commands ending with “#n”, n is the number of the 920i serial port to which the iQUBE is attached.		

Table 8-5. 920i iQUBE Diagnostic Serial Commands

Command	Description
DON. <i>b#s</i>	Set digital output on (active) at bit <i>b</i> (9–24), for <i>iQUBE</i> connected to slot <i>s</i> . NOTE: Odd numbered ports use bits 9–16; even numbered ports use bits 17–24. Example: To turn on digital output bit 1 for an <i>iQUBE</i> attached to port 3 (slot 0), use DON.9#0.
DOFF. <i>b#s</i>	Set digital output off (inactive) at bit <i>b</i> (9–24), for <i>iQUBE</i> connected to slot <i>s</i> . NOTE: Odd numbered ports use bits 9–16; even numbered ports use bits 17–24. Example: To turn off digital output bit 6 for an <i>iQUBE</i> attached to port 8 (slot2), use DOFF.22#2.
SJ.DIO.ALIAS. <i>b#n</i>	Digital I/O alias
SJ.DIO. <i>b#n</i>	Digital input function. See the <i>920i Installation Manual</i> , PN 67887, for more information
For SJ.DIO commands, digital inputs are specified by bit number ( <i>b</i> , 1–8) and the number of the <i>920i</i> serial port to which the <i>iQUBE</i> is attached ( <i>n</i> ).	

Table 8-6. DIG I/O Serial Commands

Command	Description	Values
SJ.ALG.SOURCE# <i>n</i>	Analog output source	OFF, <i>system_name</i>
SJ.ALG.FULLSC# <i>n</i>	Analog output full scale	0.000001–9999999.0
For commands ending with “# <i>n</i> ”, <i>n</i> is the number of the <i>920i</i> serial port to which the <i>iQUBE</i> is attached		

Table 8-7. ALGOUT Serial Commands (Valid Only If Analog Output Option Is Installed)

Command	Description	Values
CONTACT.COMPANY	Contact company name	<i>company_name</i> (up to 30 characters)
CONTACT.ADDR1 CONTACT.ADDR2 CONTACT.ADDR3	Contact company address	<i>company_address</i> (up to 30 characters for each line)
CONTACT.NAME1 CONTACT.NAME2 CONTACT.NAME3	Contact names	<i>contact_names</i> (up to 20 characters each)
CONTACT.PHONE1 CONTACT.PHONE2 CONTACT.PHONE3	Contact phone numbers	<i>contact_phone_numbers</i> (up to 20 characters each)
CONTACT.EMAIL	Contact e-mail address	<i>contact_e-mail_address</i> (up to 30 characters)  See Section 7.0 on page 38 for information about e-mail notification of <i>iQUBE</i> alert messages.
CONTACT.NEXTCAL	Next calibration date	<i>calibration_date</i>

Table 8-8. Contact Serial Commands

Command	Description	Values
ALERT.FMT	Alert format	See Section 7.2 on page 39 for information about specifying the alert format.
ALERT.SERV	Alert SMTP server address	0.0.0.0, <i>SMTP_server_IP_address</i>
ALERT.PRN	Alert printer port	PORT <i>n</i>

Table 8-9. Alert Serial Commands

## 9.0 Appendix

### 9.1 Troubleshooting

The following section provides information to assist for troubleshooting or repairing the *iQUBE*.

Materials needed to accomplish these steps are:

- *Revolution III* loaded onto a laptop PC. If using *Virtui*, *iRev* must be loaded on the PC
- Digital voltmeter

#### 9.1.1 General Steps

To determine that the *iQUBE* has power, check LED D1 on the core module and LEDs for the load cells assigned on each connector board (see Figure 2-2 on page 4). If no load cell LEDs (D18–D25) are on, download configuration to the *iQUBE*.

Use a voltmeter to measure the voltage at connector J10. Pin 1 should show 6 volts.

Verify communication LEDs D5 and D6 on the core module are flashing (see Figure 2-2 on page 4). If both LEDs are not flashing, check wiring and setup.

For *Virtui* applications, if the power and the LEDs are all properly lit, use the **Diagnostic** softkey to go into diagnostic mode. (This feature can be enabled in the Feature menu in Config mode.) Use the diagnostic displays to view the outputs of each load cell.

If no *Virtui* is available, connect the PC running *Revolution III* to connector J7 with switch 6 in the off position. After connecting, upload the *iQUBE* configuration to the PC to verify the proper configuration is still loaded. If not, download the correct configuration to the *iQUBE* and recalibrate. Also verify that the *iQUBE* software is the latest version.

If the configuration looks good, check the outputs of each load cell. Cell outputs should change when a weight on top of each cell or when the load cell cable is disconnected.

Use the interactive menu of *Revolution III* to monitor the cells, platforms, or systems. If any of the load cells reads incorrectly, correct the problem then test the total system again.

If these steps does not resolve the problem, contact Rice Lake Weighing Systems technical support for further assistance.

Symptom	Cause/Remedy
<i>iQUBE</i> seems dead	Verify power indicator LED on connector board is green. Cycle power by pulling the <i>iQUBE</i> fuse and watch D1 on core module cycle through red, green, then off. If it does not, turn all switches off and only turn on 8. Cycle power again. This will clear the core module.
No LEDs lit for load cells	Download from <i>Virtui</i> required after setup is completed.
Some LEDs lit green or red	Green light means good config and good cell; red indicates a load cell fault or bad A/D conversion. Swap load cell cable to another position.
No scale or <i>iQUBE</i> in <i>Virtui</i> configuration	Configuration setup and download needed to setup configuration the <i>iQUBE</i> . Ensure setup switch (DIP switch 4 on the core module) is ON to enable download from <i>Virtui</i> to <i>iQUBE</i> .
Print button causes drift	Change print format in PFORMT to send print to a port not connected to the <i>iQUBE</i> .
Slaves not configured	Cycle power on primary unit only. Secondary units will receive new configuration data.

Table 9-1. *iQUBE* Troubleshooting

Symptom	Cause/Remedy
Very large trim factors	Verify that the capacity and sensitivity of each configured load cell is correct.
Cal-Match failure	Try using a test weight with a smaller footprint. Verify communications.
Calibration shift	Possible mechanical problem or corrupted data stored in <i>iQUBE</i> . If another device connected to the <i>iQUBE</i> causes this, check for proper common grounding.
No communication	In setup of <i>iQUBE</i> , go to TESTCOM to verify communications. This step retrieves the serial numbers of the attached <i>iQUBE</i> units for verification. Check communication wiring and switches 5 and 6.
No communication with secondary unit	D7 and D8 flash for communications of the primary unit to D5 and D6 of each secondary unit. Verify connections between J4 of primary unit and J7 of each of the secondary units. Verify addresses of each card are correct. Primary = 0 (switches 1–3); Secondary = 1, 2, or 3. Verify 120Ω resistor is installed across A and B terminals of the primary (J4 connector) and last secondary unit (J7). See Figure 2-4 on page 7.
No fiber-optic communication	Check for damaged fiber cable. Verify proper connection of transmit to receive. Check RS-232 communications to determine if the communications failure is limited to the fiber communications board.
No Ethernet communication	Verify IP address and connections. Try to connect using Telnet software.
No analog output	Verify configuration is correct for the DAC board. Verify board is installed correctly. See Section 2.11.4 on page 13.

Table 9-1. *iQUBE* Troubleshooting

### 9.1.2 Technical Assistance Guide and Questionnaire

If you need to contact Rice Lake for assistance, please use the following section as a guide for troubleshooting or repair of the *iQUBE*.

1. What are the symptoms?
  
2. Is this a new installation or has the *iQUBE* been in previous working order?  
If new, go to step 3.  
If existing, go to step 13.
  
3. What is the software version for the following:  
*920i* \_\_\_\_\_  
*iQUBE* \_\_\_\_\_  
*iRev* \_\_\_\_\_  
*Revolution III* \_\_\_\_\_

- Virtui* \_\_\_\_\_
4. What communication method is being used?  
RS-232 \_\_\_\_\_  
RS-485 \_\_\_\_\_  
Fiber-optic \_\_\_\_\_  
R/F \_\_\_\_\_
  5. What is the *iQUBE* configuration?
  6. Do you have the manual for all the equipment in use?
  7. After connection, is there Voltage at the *iQUBE*?
  8. Is D1 On or Off on the connector board?
  9. **If using a 920i**, continue to step 10.  
**If using Revolution III**, access cell monitoring Via the interactive tab and proceed to step 18  
**If using Virtui**, access cell monitoring and proceed to step 18
  10. What is the distance from the 920i to the scale?
  11. What port is the *iQUBE* on?  
If using port 3, ensure printer ports are not still set to the default port 3.
  12. With the communications on, using *TESTCOM*, are D5 and D6 or D7 and D8 flashing?
  13. If using *iRev*, is the *CONFIG* already set up and ready to download?
  14. Set up the diagnostic key.
  15. Does the download complete to the 920i without error?
  16. Did the 920i send the data to the *iQUBE*?
  17. Does the Cal-Match work?
  18. When the scale is empty, are all the current readings near the captured zero?  
If yes, go to step 19.  
If no, go to step 20.
  19. With weight on the scale, do all of the current readings rise to the same degree?  
If yes, go to step 20.  
If no, go to step 21.

20. Is the adjusted weight, in the lower right corner, reading a weight or 000000?  
If the adjusted weight is showing a good weight, the problem is within the 920i configuration  
If the adjusted weight is displaying 000000, the *iQUBE* has lost calibration or the core has gone bad.
21. Is one single cell reading bad?  
If yes, go to step 22.  
If no, go to step 26.
22. Is the single cell reading 62mV?  
If yes, the cell bridge is open or there is a bad cell. Check the signal and go to step 27.  
If no, go to step 23.
23. Is a single cell reading around -16 mv?  
If yes, the negative excitation wire is broken or disconnected.
24. Compared to the other cells, is the single cell reading very low?  
If yes, the + EXC wire is broken.
25. Is the cell reading high, low or not moving?  
This could be a binding cell or some other mechanical problem.
26. Is the bad cell on a slave only?
27. Open the J-box(s).
28. If using a slave, are the comm lights D7 and D8 on the master flashing?
29. Are all the lights green for the correct number of cells?
30. For any red lights, pull the wires and check bridge resistance.
31. If everything is correct, proceed with a theoretical calibration.
32. If the theoretical calibration works, proceed with a Cal-Match final calibration.

## 9.2 Printed Information

### *iQUBE* Options

- *iQUBE Remote Fiber-Optic Interface Installation Instructions*, PN 80230

### *Virtui* System Manuals

- *Virtui Installation Manual*, PN 67887

- *iRite™ Programming Reference*, PN 67888

#### Virtui Option Cards

- *Virtui Single-Channel A/D Card Installation Instructions*, PN 69092
- *Virtui Dual-Channel A/D Card Installation Instructions*, PN 69090
- *Virtui 24-Channel Digital I/O Expansion Card Installation Instructions*, PN 69087
- *Virtui Serial Expansion Card Installation Instructions*, PN 69088
- *Virtui Pulse Input Card Installation Instructions*, PN 69086
- *Virtui Memory Expansion Card Installation Instructions*, PN 69085

#### 520/920i Communications Options

- *DeviceNet™ Interface Installation and Programming Manual*, PN 69949
- *Profibus® DP Interface Installation and Programming Manual*, PN 69948
- *Allen-Bradley® Remote I/O Interface Installation and Programming Manual*, PN 69950
- *Ethernet Communications Card Installation Instructions*, PN 72117

## 9.3 Flash Update Procedure

Before beginning this procedure, ensure that there are no other processes running on the PC and that the cable from the programmer is plugged into the PC cable.

1. Insert core board in the *iQUBE* grey box test fixture or production box.
2. Remove the two jumpers on J3.
3. Connect the blue connector to J3 with red wire to the edge of the board.
4. Turn on the power.
5. Double click **AVRSTUDIO4** (LadyBug). This is available on the CD included in the parts kit or at <http://www.atmel.com>.  
"Welcome to AVR Studio"
6. Select **Cancel** when *iQUBE* project is displayed.
7. Click **Next**.
8. Select the device **Atmega128**
9. Click **Finish**.
10. Click the **AVR** button, it looks like an EEPROM.
11. A warning to upgrade may appear.
12. Click **Cancel**.
13. Go to lock Bits and ensure that all are on Mode 1.
14. Click **Program** to send Locks to core module.
15. Go to the Fuse tab and ensure that only the following fuses are set.
  - WatchDog Timer On
  - Preserve EEPROM
  - Boot Glash = 512
  - CKOPT Fuse
  - BrownOut = 2.7v
  - BrownOut Detection Enabled
  - Ext Crystal last box in list
16. Click **Program** to send fuses to core module.
17. Locate Flash Box.
18. Click **Program**.
19. Verify that there are no errors.
20. Turn power off.
21. Disconnect the blue connector.

22. Replace the two jumpers J3 that were removed in step 2.
23. Place new label, 2145 on the CPU chip.

## 9.4 Software Version Updates

Version Number	Update
10243	Initial Release
12283	Protocol change from iQUBE - requires 920i version 2.01
05054	Remote diagnostic LED error corrected Reordering of the captured Cal-Match matrix Emmulator 2 added
06254	(Not released) Improved Cal-Match for small changes in load cell output Changed operation of temperature compensation
0704a	Corrected communication problem between core module and remote boards
0714b	Corrected the remote board intermittent communication problem
2145	Changed master error bit polarity Operation of temperature compensation Communications handshaking Selection of baud rates

Table 9-2. iQUBE Software Version Updates

## 9.5 Specifications

### Power

Power Consumption (+6 VDC)  
 4-channel, 4 x 350Ω load cells 91 mA (0.546 W)  
 8-channel, 8 x 350Ω load cells 134 mA (0.810 W)

Fuse 2A TR5 subminiature fuse  
 Wickmann Time-Lag 19374 Series  
 UL Listed, CSA Certified and Approved

### A/D Specifications

Excitation Voltage 4 VDC (+4V and ground, single-sided)  
 Analog Signal Input Range -11.7 mV to +27.3 mV  
 A/D Sample Rate 15 Hz per channel

### Serial Communications

J7 Port Full duplex RS-232 or RS-485. Can be routed through J6 for Ethernet or fiber-optic cabling.  
 J4 Port 4-wire RS-485 only

### Environmental

Operating Temperature -10 to +40°C (14 to 104°F)  
 Storage Temperature -10 to +70°C (14 to 158°F)  
 Humidity 0-95% relative humidity

### Enclosure

Enclosure Dimensions 11.5 in x 8.25 in x 5.25 in  
 29 cm x 21 cm x 13 cm  
 Weight 8.0 lb (4 Kg)  
 Rating/Material NEMA 4X

### Certifications and Approvals



NTEP  
 CoC Number 03-032  
 Accuracy Class III/IIIL  $n_{max}$ : 10 00000



UL  
 File Number: E151461

# iQUBE Limited Warranty

---

Rice Lake Weighing Systems (RLWS) warrants that all RLWS equipment and systems properly installed by a Distributor or Original Equipment Manufacturer (OEM) will operate per written specifications as confirmed by the Distributor/OEM and accepted by RLWS. All systems and components are warranted against defects in materials and workmanship for two years.

RLWS warrants that the equipment sold hereunder will conform to the current written specifications authorized by RLWS. RLWS warrants the equipment against faulty workmanship and defective materials. If any equipment fails to conform to these warranties, RLWS will, at its option, repair or replace such goods returned within the warranty period subject to the following conditions:

- Upon discovery by Buyer of such nonconformity, RLWS will be given prompt written notice with a detailed explanation of the alleged deficiencies.
- Individual electronic components returned to RLWS for warranty purposes must be packaged to prevent electrostatic discharge (ESD) damage in shipment. Packaging requirements are listed in a publication, *Protecting Your Components From Static Damage in Shipment*, available from RLWS Equipment Return Department.
- Examination of such equipment by RLWS confirms that the nonconformity actually exists, and was not caused by accident, misuse, neglect, alteration, improper installation, improper repair or improper testing; RLWS shall be the sole judge of all alleged non-conformities.
- Such equipment has not been modified, altered, or changed by any person other than RLWS or its duly authorized repair agents.
- RLWS will have a reasonable time to repair or replace the defective equipment. Buyer is responsible for shipping charges both ways.
- In no event will RLWS be responsible for travel time or on-location repairs, including assembly or disassembly of equipment, nor will RLWS be liable for the cost of any repairs made by others.

**THESE WARRANTIES EXCLUDE ALL OTHER WARRANTIES, EXPRESSED OR IMPLIED, INCLUDING WITHOUT LIMITATION WARRANTIES OF MERCHANTABILITY OR FITNESS FOR A PARTICULAR PURPOSE. NEITHER RLWS NOR DISTRIBUTOR WILL, IN ANY EVENT, BE LIABLE FOR INCIDENTAL OR CONSEQUENTIAL DAMAGES.**

**RLWS AND BUYER AGREE THAT RLWS'S SOLE AND EXCLUSIVE LIABILITY HEREUNDER IS LIMITED TO REPAIR OR REPLACEMENT OF SUCH GOODS. IN ACCEPTING THIS WARRANTY, THE BUYER WAIVES ANY AND ALL OTHER CLAIMS TO WARRANTY.**

**SHOULD THE SELLER BE OTHER THAN RLWS, THE BUYER AGREES TO LOOK ONLY TO THE SELLER FOR WARRANTY CLAIMS.**

**NO TERMS, CONDITIONS, UNDERSTANDING, OR AGREEMENTS PURPORTING TO MODIFY THE TERMS OF THIS WARRANTY SHALL HAVE ANY LEGAL EFFECT UNLESS MADE IN WRITING AND SIGNED BY A CORPORATE OFFICER OF RLWS AND THE BUYER.**

© 2006 Rice Lake Weighing Systems, Inc. Rice Lake, WI USA. All Rights Reserved.

RICE LAKE WEIGHING SYSTEMS • 230 WEST COLEMAN STREET • RICE LAKE, WISCONSIN 54868 • USA

DISCONTINUED

DISCONTINUED

DISCONTINUED



230 W. Coleman St. • Rice Lake, WI 54868 • USA  
U.S. 800-472-6703 • Canada/Mexico 800-321-6703  
International 715-234-9171

**[www.ricelake.com](http://www.ricelake.com)**

**mobile: [m.ricelake.com](http://m.ricelake.com)**

© 2011 Rice Lake Weighing Systems PN 77224 06/11