



When Accuracy Counts

DI-28

Mini-Bench Scale

Operation Manual

DI-28 SERIES OPERATING MANUAL

<u>SECTION</u>	<u>INDEX</u>	<u>PAGE NUMBER</u>
1.0.	<u>GENERAL</u>	2
	1.1. Description	2
2.0.	<u>SPECIFICATIONS</u>	3
	2.1. Platforms & Capacities	3
	2.2. Technical	4
3.0.	<u>INSTALLATION</u>	5
	3.1. Unpacking	5
	3.2. Inspection	5
	3.3. Repackaging	5
	3.4. Mini Grand Unlocking Procedure	5-7
	3.5. Mini Grand Assembly	8-9
4.0.	<u>ELECTRICAL TEST</u>	10
	4.1. Set-Up Procedure	10
	4.2. Keyboard & Display Test	10
	4.3. Control Panel	11
	4.3.1. Lamps	11
	4.3.2. Keys	11
5.0.	<u>OPERATION PROCEDURE</u>	12
	5.1. Power On	12
	5.2. Tare Subtraction	12
	5.2.1. One Touch Tare	12
	5.2.2. Digital Tare	12
	5.3. Battery Life Check	12
	5.4. Set Point Value Entry	13
	5.5. Changing Weight Units	13
6.0.	<u>PROGRAMMING</u>	14
	6.1. DI-28 Key Function Summary	14
	6.2. Internal Count	14
	6.3. Set Up And Calibration	15
	6.4. Specification List	15-17
	6.5. Span Adjustment	17-18
	6.6. Span Enable Switch	18
7.0.	<u>DI-20 OPTIONS</u>	19
	7.1. Battery Option	19
	7.2. Set Point Output, & Setpoint Wiring	21
	7.3. RS-232, RS-232 Wiring	21-27
8.0.	<u>MAINTENANCE, CALIBRATION, TEST PROCEDURE, SERVICE</u>	28
	8.1. Maintenance Procedures	28
	8.2. Service & Repair	29
	8.3. Load Cell Wiring	29
	8.4. Limited Warranty	30

1.0. GENERAL

1.1. Features

The DI-28 Indicator offers a practical solution to a wide range of weighing applications. There are a variety of weight capacities and increments available. The display resolution is selectable from 1/2000 to 1/7500. It features RS-232 & 4 Setpoint outputs (factory options) and keyboard calibration with auto-span. It operates on 6 “C” cell batteries or with its AC/DC adapter. The DI-28 is able to support single load cells that have an output range of 0.4mV/V to 4.0mV/V and is able to support up to 4 load cells when used with the AC/DC adapter. This indicator features ON/OFF, REZERO, TARE, for both one touch and digital key operation. A recharging circuit is incorporated for use with rechargeable NiCAD batteries. For a list of platforms sizes and available capacities see page 3.

This instruction manual will provide the user with all the information necessary to understand, set-up and operate the DI-28 scale. Included in this manual are descriptions, specifications, drawings, and operating instructions.

2.0. SPECIFICATIONS

This section includes a detailed listing of all pertinent specifications and parameters for each of the DI-28 weighing scales. The system weighing accuracy is 0.02 % for all models and they meet or exceed the requirements of OIML Class III and NIST Handbook, Number 44.

2.1 Platforms

The following is a list of platforms :

Model		Platform Size/Platter	Capacities				
S-AL	bench	12" x 14" x3"	1 LB.	5 LB.	10 LB.	25 LB.	50 LB.
S-SL	bench / floor	13" x 17"	60 LB.		150 LB.		300 LB.
S-TL	floor	17" x 21"	150 LB.	300 LB.	500 LB.		1000 LB.
S-UL	floor	24" x 28"	150 LB.	300 LB.	500 LB.		1000 LB.
S-PL	floor	30" x 30" 36" x 36"	1000 lb. to 3000 lb.				
S-PL	floor	48" x 48" 48" x 72" 60" x 60" 60" x 84"	2500 lb. to 25000 lb.				

Ramps , Other Capacities And Stainless Steel Platforms Also Available

Choosing A Capacity :Decimal Location (*) Minimum Weight (*) Display Resolution (=) Capacity

Decimal Location	Minimum Weight	Display Resolution	Available Capacities
0.0000	1	1 / 2000	1lb,2.5lb,3lb.,5lb.,6lb.,
0.000	2	1 / 2500	10lb.,25lb.,30lb.,50lb.,
0.00	5	1 / 3000	60lb.,75lb.,100lb.,125lb
0.0		1 / 5000	150lb.,200lb.,250lb.,
0		1 / 6000	300lb.,375lb.,500lb.,
		1 / 7500	600lb.,750lb.,1000lb.,
			1500lb.,2000lb.,2500lb.
			3000lb.,3750lb.,5000lb.
			6000lb.,7500lb.,10000lb

Example: dec. loc. (*) min. wt. (*) disp. res. = avail cap.

0.00 (*) 5 (*) 1 / 7500 = 375. 00 lb.

* Units can be programmed to primarily weigh in lb., oz., kg., g., or dwt.

2.2. SPECIFICATIONS Technical

2.2.1. Id Plate :

Model # DI-28

Serial #

Power Dissipation .3w

Voltage Battery size C 6x1.5v or 12v AC Adapter

2.2.2. Operating Conditions :

Power source : AC/DC adapter (12V, Digi Model PS-100 only, See 2.2.4. below) or 6x 1.5V size C battery, alkaline or rechargeable.

Temperature Range : -10° to $+40^{\circ}$ C.

Humidity : 15% to 85% R.H.

Power Consumption : 0.3 to 1.5 Watts.

2.2.3. Display Specifications

Display Device: LCD (Liquid Crystal Display)
Character Height, 25mm.

No. of Digits: 6 Digits (including minus sign digit)

2.2.4. AC/DC Adapter Specifications

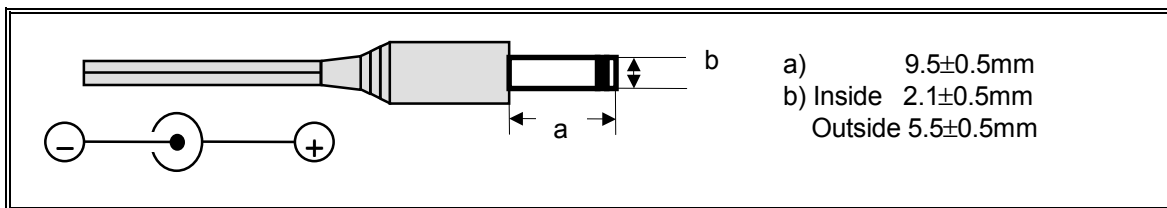

3.0. INSTALLATION

This section provides the information required for installation of the DI-28 weight indicator. The following steps accomplish installation.

1. Unpacking
2. Set-up Procedure

3.1. Unpacking

Each component of the DI-28 is packed in a specially designed carton. Remove each component from the carton, separate the component from its polystyrene shell assembly and set aside. Inspect the carton interior to be sure that all accessories have been removed from the carton. Inspect the carton inner panels for accessories.

NOTE: Be sure to repack all materials within the carton set. Store the cartons in a secure area so they can be available whenever shipment of the scale is required.

3.2. Inspection

Immediately after unpacking, a visual inspection of the instrument should be performed. If any damage has been incurred during transportation the shipper and DIGI MATEX INC. should be notified immediately. Instructions for assessment of damage and further procedures will then be determined.

3.3. Repackaging

If, at anytime, the DI-28 weight indicator must be returned for modification, calibration, or repair, be sure that it is properly packed with sufficient cushioning materials.

Whenever possible, the original carton assembly should be retained for this purpose. Any damage caused by improper packaging will not be covered by warranty.

3.4. Platform Unlocking Procedure

The unlocking procedure is different for each style of platform and is included on the following pages.

3.5. Mini Grand Pole Assembly

The optional pole mounting kit comes with all the necessary hardware and assembly is easy. See pages 8 & 9 for details.

3.4.1. Unlocking Procedure

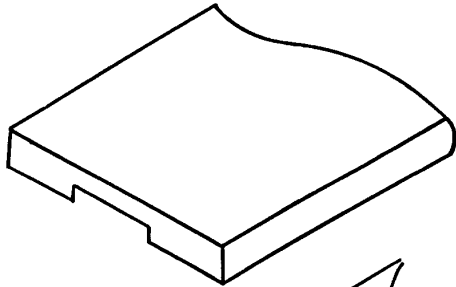

S-SL TYPE
&
S-UL TYPE

REMOVE THE UNLOCKING SCREW
BEFORE USING

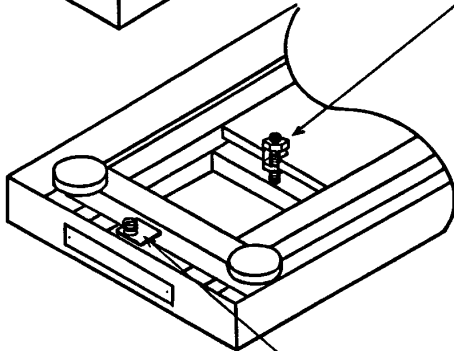

S-TL TYPE

REMOVE LOCKING SCREW
BEFORE USING

SM, SN, SO-L TYPE

BEFORE USING THE SCALE,
REMOVE THE TWO NUTS AND
THE SCREWS AS SHOWN BELOW

(Hexagon socket set screws and nuts)

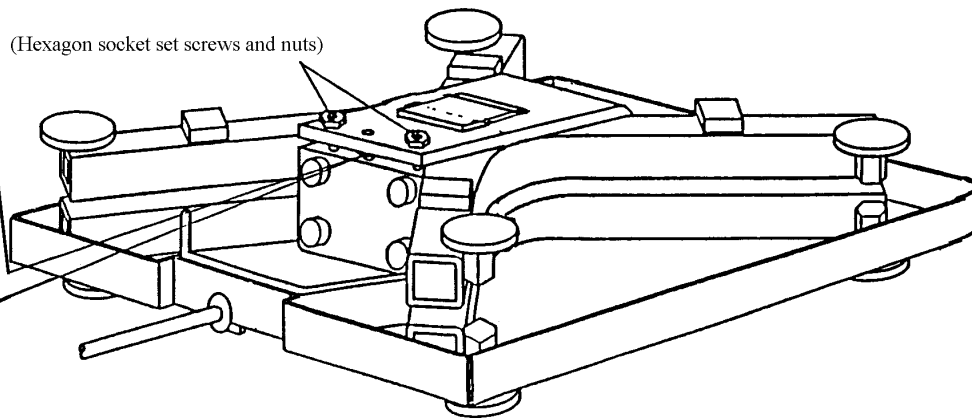

DO NOT
adjust this screw!
(overload stop)

3.4.2. Unlocking Procedure

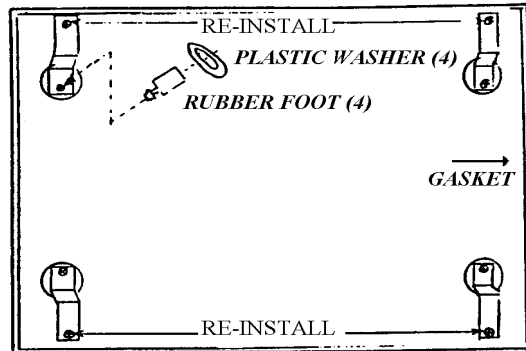

1. Remove & Save All (4) Locking Brackets.
2. Re-insall Outside Screws.
3. Install (4) Rubber Feet.
4. Install (4) Plastic Washers.
5. Place Platter Onto Rubber Feet.

*UNLOCKING PROCEDURE for:
SA-L (EPIC PLATFORM)
10 lb., 25 lb., & 50 lb. capacities.*

NOTE:
Be SURE GASKET FITS
SNUG AND WILL NOT
RUB AGAINST PLATFORM

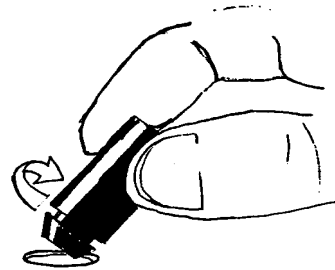

PUSH IN AND TWIST RUBBER FOOT

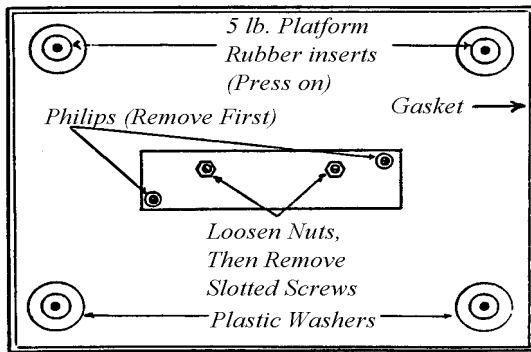

UNLOCKING PROCEDURE: For 1 lb. & 5 lb. SA-1 (EPIC)

1. Remove Locking Plate Corner Screw.
2. Loosen Locking Nuts.
3. Unscrew Locking Posts And Remove Plate Assembly.
4. Install Weighing Platter.
 - (a) For 5 lb. Platform, Twist-on Rubber Platter Supports.
 - (b) For 1 lb. Platform, Install 2 Side Rails And The 4" x 6" Tray.

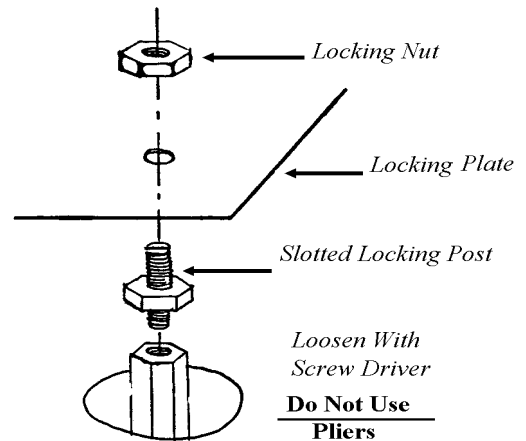

NOTE:
Be Sure Gasket Fits Snug
And Does Not Rub Against
The 5 lb. Platter

3.5.1. Mini Grand Assembly

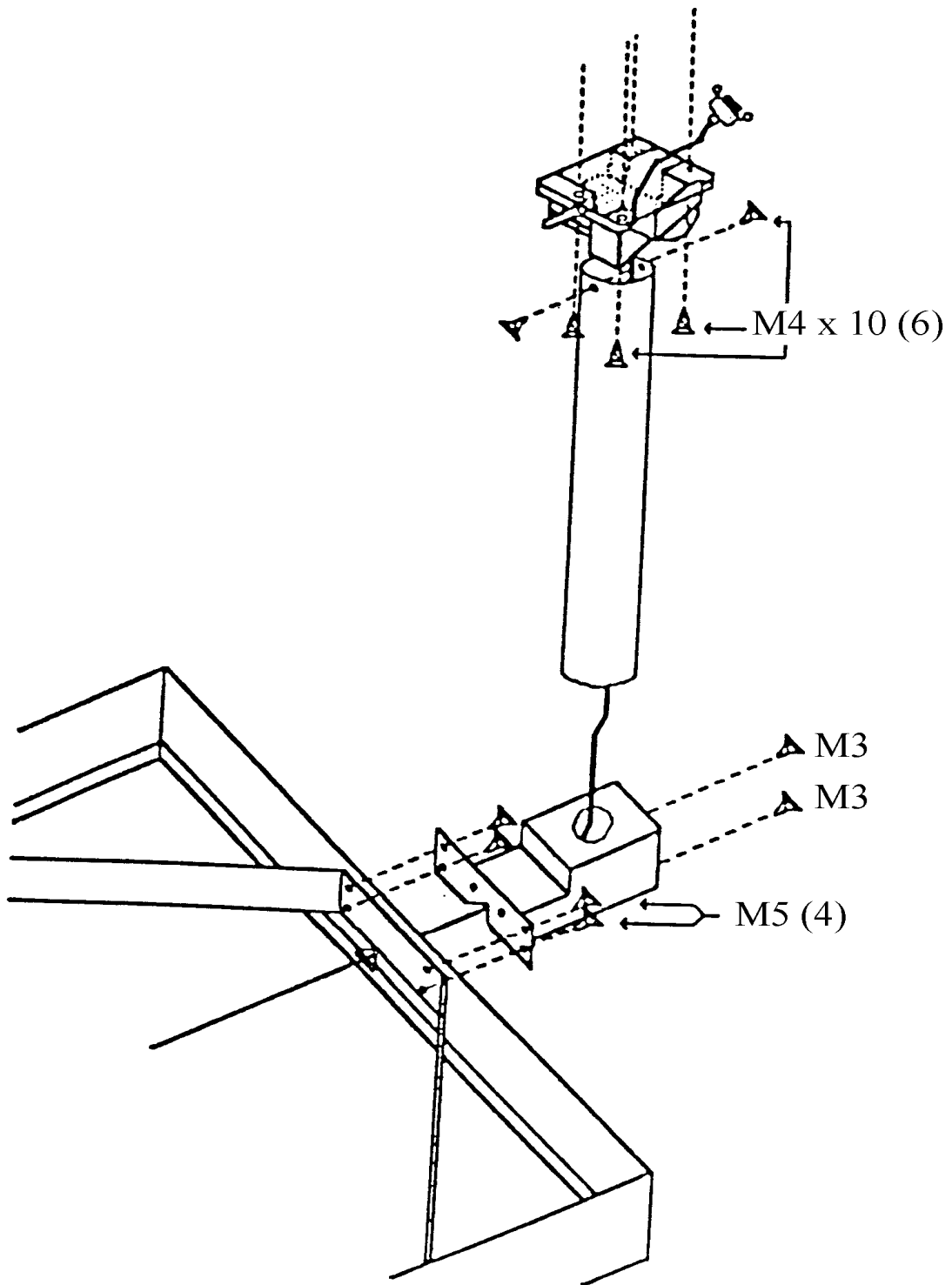

3.5.2. DI-28 Adapter Plate

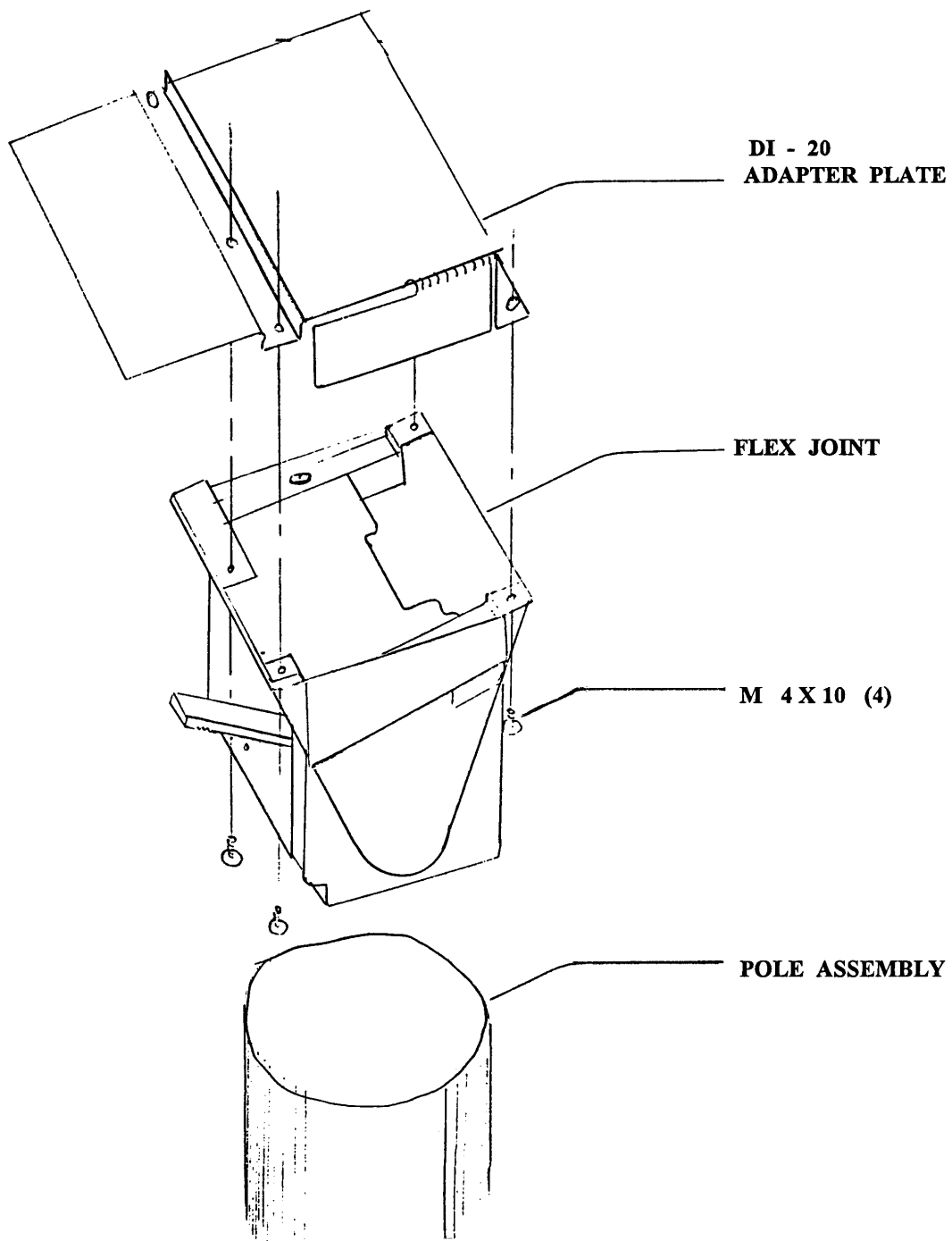

4.0. ELECTRICAL TEST

4.1. Set-up Procedure

This part of the procedure is used to verify proper operation of the scale.

Connect the AC power source, and press the [ON/OFF] key. At turn-on, the display will momentarily show the version number then, all digits from 0 to 9 in a “count-up” mode. Then the display will blank, show all “8’s”, and enter the regular operating display.

If at any time the scale displays erratic data, it may be caused by a power transient. Turn the scale “off” and momentarily unplug it from the wall outlet. Then restart, by plugging the scale back in and pressing the [ON/OFF] key.

4.2. Keyboard and Display

This part of the procedure is used to verify proper operation of various switches and displays. The following functions will be tested in this procedure:

- A. Tare Entry
- B. Digital Tare Entry

4.2.1. One Touch Tare

- a. Press [REZERO] key, to rezero the scale.
- b. Place the empty container on the scale and press the [TARE] key once.

The Weight Display should now read zero with the empty container on the scale.

4.2.2. Digital Tare Entry

- a. Press the [REZERO] key. After resetting, the display will read zero.
- b. Enter the number 0.2 by using the keyboard, select the digit to change using [← DIGIT] key, then press [↑ INCR] key for the desired Tare value. Then press the [TARE] key.

The Weight Display will show the weight entered with a negative sign indicating that the weight displayed is a Tare Weight.

4.3. Control Panels

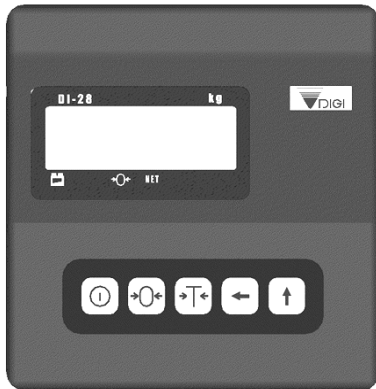

4.3.1. Keys

Key	Name	Functions
	ON/OFF	Turn power on or off.
	REZERO	Reset the weight to zero.
	TARE	Enter or clear tare value.
	DIGIT SELECT	Select the digits to set tare or setpoint value.
	INCREASE	Increase the value of tare or setpoint weight on selected digit when setting data. Manual transmit key for RS-232 output.

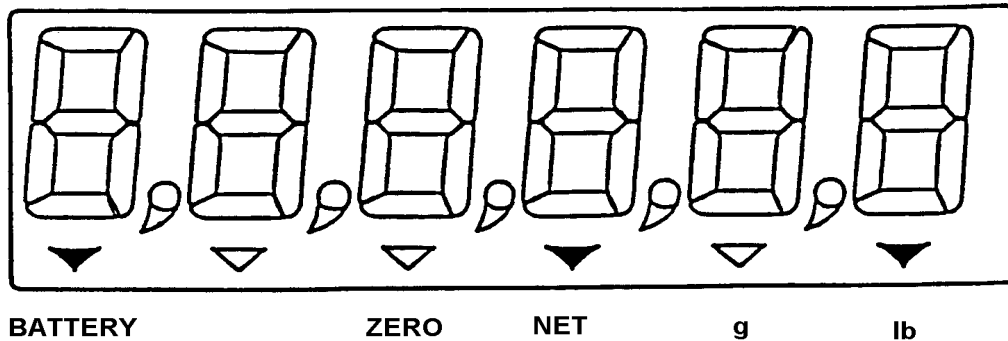

4.3.2. Lamps

Indicators	Name	Functions
	BATTERY LAMP	On when battery becomes too weak and needs to be replaced/ recharged.
	ZERO LAMP	On when weight is stable at zero point.
NET	NET LAMP	On when tare is subtracted.
g	GRAM LAMP	On when grams are used as weighing unit.
lb/kg	LB/KG LAMP	On when pounds are used as weighing unit.



5. Operation Procedure

5.1 Power On

PROCEDURE	KEY OPERATION	DISPLAY	REMARKS
Connect DI-28 to power supply.			
1. Make sure nothing is on the platform, and press [ON/OFF] key.		Ver0.01	Show Software Version
		000000	Segment check starts.
		888888	
		0.000	Ready for weighing







5.2 Tare Subtraction

5.2a One touch tare

PROCEDURE	KEY OPERATION	DISPLAY	INDICATOR		
				→0←	NET
Stand-by status		0.000		◆	
1. Place tare weight on the platform.	e.g. 0.010 kg	0.010			
2. Press [TARE] key.		0.000			◆
3. Remove the tare weight.		-0.010		◆	◆

Note 1) To clear the tare weight, remove tare from the load receptor then, press [TARE] key.

5.2b Digital tare entry (When the tare weight is known)







PROCEDURE	KEY OPERATION	DISPLAY	INDICATOR		
				→0←	NET
Stand-by status		0.000		◆	
1. Move cursor to the left two digits.	 	t00.0"0"0			
2. Set tare value by increasing the value.	 	t00.0"2"0			
3. Enter the tare value.		-0.020		◆	◆

Note 1) To clear the tare weight, press [TARE] key.

Note 2) "0" and "2" means that the cursor is blinking.























5.3. Battery Life Check

The battery life can be checked

PROCEDURE	KEY OPERATION	DISPLAY	INDICATOR		
				→0←	NET
Stand-by status		0.000		◆	
1. Press [TARE], [←], [TARE] key while pressing [RE-ZERO] key.	 +   	□ □ □ □ □ □			
2. Press [TARE] key to be back to weighing mode.		0.000		◆	







The number of boxes in the display indicates the battery power. When batteries are fully charged, 6 boxes appear. As the battery is running out of power, the number of boxes will decrease gradually.

5.4 Setpoint Value Entry

PROCEDURE	KEY OPERATION	DISPLAY	INDICATOR				
				→0←	NET	g	lb
Stand-by status		0.000		◆			
1. Enter the setpoint entry mode by pressing [↑] three times while pressing [RE-ZERO] key.	 +  ,  	00.000					
2. Enter Setpoint 1 value by using [↑] and [←] keys.	 , 	01.000					
3. Store the data.		00.000					
4. Enter Setpoint 2 value by using [↑] and [←] keys.	 ,  , 	02.000					
5. Store the data.		00.000					
6. Enter Setpoint 3 value by using [↑] and [←] keys.	 ,  ,  	03.000					
7. Store the data.		00.000					
8. Enter Setpoint 4 value by using [↑] and [←] keys.	 ,  ,   , 	04.000					
9. Store the data.		0.000		◆			

Note: To exit from setpoint entry mode without storing the data, press [TARE] key instead of [RE-ZERO] key.

5.5. Changing Weight Units (kg , g , lb)

PROCEDURE	KEY OPERATION	DISPLAY	INDICATOR				
				→0←	NET	g	lb
Stand-by status		0.000		◆			
1. Allow user to switch between KG, g and lb. (Assuming scale is calibrated in KG.)		5.000 (Ex. 5kg)					
2. To switch to g Press [REZERO] key and hold followed by [↑] then release [REZERO]	 + 	5000 (Ex. 5000g)				◆	
3. To switch to lb Press [REZERO] key and hold followed by [↑] then release [REZERO]	 + 	11.023 (Ex. 11.023lb)					◆
4. To switch to kg Press [REZERO] key and hold followed by [↑] then release [REZERO]	 + 	5.000 (Ex. 5kg)					

6.0. PROGRAM MODE

6.1. DI-28 Key Function Summary

KEY	REZERO	TARE	← DIGIT	↑ INCREASE
INTERNAL COUNT REZERO (D D T)	REZERO	EXIT	----	CHANGE MODE
OPERATIONAL SPECS REZRO (D D D)	STORE & INCREMENT SPEC	EXIT	INPUT 0	INPUT 1
W & M SPECS REZERO (D T D)	STORE & INCREMENT SPEC	EXIT	INPUT 0	INPUT 1
SPAN ADJUSTMENT REZERO (D T T)	STORE / RDY FOR CAL	EXIT	SELECT DIGIT	INCREASE NUMBER
SET POINT PROGRAMMING REZERO (I I I)	STORE & INCREMENT SET POINT	EXIT	SELECT DIGIT	INCREASE NUMBER
SPAN SWITCH STATUS REZERO (T D D)	----	----	----	----
BATTERY LIFE CHECK REZERO (T D T)	----	EXIT	----	----

D = ←DIGIT

I = ↑INCR

T = TARE

6.2. Internal Count

This function is provided to check the internal count value from the A/D (pre-amp)

To Enter Internal AD Count Mode

1. Press and hold down the [REZERO] key.
2. While holding , press the [← DIGIT] key two times, the [TARE] key once.
3. Then release the [REZERO] key.

In This Mode, Each Key Functions As Follows

[↑ INCREASE] key	Used to switch between internal count and A/D Raw Data
[REZERO] key	Used to rezero the internal counts
[TARE] key	Used to exit from internal count mode

6.3. Set Up And Calibration

6.3.1. Specification Change

Function key for spec. change.

Accessing Operational Specs. (50 - 59)

1. Press and hold down the [REZERO] key.
2. While holding , press the [← DIGIT] key three times .
3. Then release the [REZERO] key.

In This Mode, Each Key Functions As Follows

[← DIGIT] key	Used to input 0
[↑ INCREASE] key	Used to input 1
[REZERO] key	Used to save the specification and increment to the next specification
[TARE] key	Used to exit from specification mode

THE SLEEP TIMER IS LOCATED IN OPERATIONAL SPECS.

Spec.50 = sleep timer (0000 = none to 1111 = 15 min.)

6.3.2. Specification Change (Continued)

Function key for spec. change.

Accessing Weights & Measures Specs. (00 - 09 / 20 - 29)

1. Press and hold down the [REZERO] key.
2. While holding , press the [← DIGIT] key, the [TARE] key, the [← DIGIT] key.
3. Then release the [REZERO] key.

In This Mode, Each Key Functions As Follows

[← DIGIT] key	Used to input 0
[↑ INCREASE] key	Used to input 1
[REZERO] key	Used to save the specification and increment to the next specification
[TARE] key	Used to exit from specification mode

6.4. Di - 28 Specification List

6.4.1. DI - 28 W & M Specs.

W & M SPECS. PRESS AND HOLD REZERO THEN PRESS (D - T - D)				
Spec. No.	BIT 3	BIT 2	BIT 1	BIT 0
Spec. 00	Not Used			
Spec. 01	Comma or Dec. Pt. 0 = comma, 1 = dec.pt.	Not Used	Decimal Point Position 00 = no dec.pos. 10 = two dec.pos. 01 = one dec.pos. 11 = three dec.pos.	
Spec. 2	Not Used			
Spec. 3	Change Weight Units 0 = no, 1 = yes	Scale Type 0 = kg , 1 = lb	Internal Count When Span SW off 0 = no, 1 = yes	Not Used
Spec. 04-09	Not Used			
Spec. 20	Tare Accumulate 0 = no, 1 = yes	Not Used	Digital Tare 0 = no, 1 = yes	Tare Limit 0 = 50%, 1 = 100%
Spec. 21	One Touch Tare Clear 0 = no, 1 = yes	Rezero In Tare 0 = no, 1 = yes	Not Used	Not Used
Spec. 22-23	Not Used			
Spec. 24	load cell sensitivity (mv/V)			
	0000 = 4.00mV/V	0100 = 3.00mV/V	1000 = 2.00mV/V	1100 = 1.00mV/V
	0001 = 3.75mV/V	0101 = 2.75mV/V	1001 = 1.75mV/V	1101 = 0.80mV/V
	0010 = 3.50mV/V	0110 = 2.50mV/V	1010 = 1.50mV/V	1110 = 0.70mV/V
	0011 = 3.25mV/V	0111 = 2.25mV/V	1011 = 1.25mV/V	1111 = 0.60mV/V
Spec. 25	Not Used	Not Used	Ignore Span Switch 0 = no, 1 = yes	Recall Zero 0 = no, 1 = yes
Spec. 26-27	Not Used			
Spec. 28	Not Used	Minus Weight 0 = 9 ext. increments, 1 = No Limit	Zero Reset Range 0 = ± 10% , 1 = ± 100%	Re-Zero Range 0 = ± 2 % , 1 = ± 100%
Spec. 29	Not Used			

6.4. DI - 28 Specification List (Continued)

6.4.2. DI - 28 Operational Specs.

OPERATIONAL SPECS. PRESS AND HOLD REZERO THEN PRESS (D - D - D)				
Spec. No.	BIT 3	BIT 2	BIT 1	BIT 0
Spec. 50	Sleep Timer			
	0000 = None 0001 = 1 Min. 0010 = 2 Min. 0011 = 3 Min.	0100 = 4 Min. 0101 = 5 Min. 0110 = 6 Min. 0111 = 7 Min.	1000 = 8 Min. 1001 = 9 Min. 1010 = 10 Min. 1011 = 11 Min.	1100 = 12 Min. 1101 = 13 Min. 1110 = 14 Min. 1111 = 15 Min.
Spec. 51	Not Used	Power Save 0 = no, 1 = yes	Motion Detection 0 = strong , 1 = weak	Animal Mode 0 = no, 1 = yes
Spec. 52	Handshaking for RS-232 0 = no, 1 = yes	Send STX Before Text 0 = no, 1 = yes	Set Point Output 0 = active low, 1 = active high	Set Point 0 = disable, 1 = enable
Spec. 53	RS-232 Stable Flag 0 = without flag 1 = with stable flag	RS-232 Data Format 0 = without header 1 = with header	Non-Stable Output 0 = no, 1 = yes	Send Header As Text 0 = no, 1 = yes
Spec. 54	RS - 232 Output 0 = Disable 1 = Enable	0 0 0 = 1200 bps 0 1 1 = 9600 bps	Baud Rate 0 0 1 = 2400 bps 1 0 0 = 19200 bps	0 1 0 = 4800 bps
Spec. 55	Parity 0 0 = no parity	0 1 = odd 1 0 = even	Stop Bit 0 = 1 bit 1 = 2 bits	Data Length 0 = 7 bits 1 = 8 bits
Spec. 56-58	Not Used			
Spec. 59	Remote Trigger 0 = Disable 1 = Enable	Communication Mode 0 = stream 1 = manual	RS-232 Time Out 0 0 = 1 sec. 0 1 = 3 sec.	1 0 = 5 sec. 1 1 = 10 sec.

6.5.1. Span Adjustment

This Mode Is Provided To Calibrate Scale

Accessing Calibration Mode

1. Press and hold down the [REZERO] key.
2. While holding , press the [← DIGIT] key, the [TARE] key, the [TARE] key.
3. Then release the [REZERO] key.

In This Mode, Each Key Functions As Follows

[↑ INCREASE] key	Used to increase value of digit
[← DIGIT] key	Used to change digits as needed
[REZERO] key	Used to save changes and advance through calibration
[TARE] key	Used to exit calibration mode without saving changes

6.5.2. Calibration Procedure

PROCEDURE	KEY OPERATION	DISPLAY	Remarks
1. Enter calibration mode.	[REZERO] [← DIGIT] [TARE] [TARE]	888888 1	Press and hold [REZERO] key while pressing [DIGIT], [TARE], [TARE] then release [REZERO] key.
2. Enter the minimum display.	[↑ INCR] [REZERO]	2 [00.000 ∇	Press [↑ INCR] key. (Ex. 0.002) Press [REZERO] to advance through calibration
3. Enter the capacity weight.	[←] [↑][↑][↑][↑][↑] [↑][↑]	[06.000 ∇	Press [DIGIT] once and [↑ INCR] key six times. (Ex. 6KG)
	[REZERO]	< 06.000 ∇	Press [REZERO] to advance through calibration
4. Enter weight to be used for calibration. (If other than capacity.)	[←] [↑][↑][↑][↑][↑] [↑][↑]	< 02.000 ∇	Press [DIGIT] once and [↑ INCR] key six times. (Ex. 2KG)
	[REZERO]	CAL 0	Press [REZERO] to advance through calibration
5. Set zero point.	[REZERO]	CAL SP	
6. Place weight on platter from step 4.	[REZERO]	xxxxxx	When calibration is complete scale shows internal count.
7. Exit internal count mode.	[TARE]	xx.xxx	Press [TARE] key to return to weighing mode.
8. Rezero scale place weight on scale to test calibration.	[REZERO]		

6.6. Span Enable Switch Check

This Mode Is Provided To Check The Status of The Span Switch. The SPAN SWITCH is on the main board near the pre-amp housing and is labeled JP 1. See Figure on Page 19.

Accessing Mode

1. Press and hold down the [REZERO] key.
2. While holding , press the [TARE] key, the [← DIGIT] key, the [← DIGIT] key.
3. Then release the [REZERO] key.

When Calibration is enabled Display Shows : S- ON

7.0. OPTIONS

7.1. Battery Options

The DI-28 may be used with an A/C adapter or with batteries for portable operation. The indicator requires 6 x 1.5V size C battery. Alkaline or rechargeable batteries may be used. There is a built in charging circuit controlled by a jumper JP-2, which is located on the main board near the power connector. The jumper must be set for the type of battery being used and is normally set for alkaline. *See figure below for switch position*

FIGURE 1:

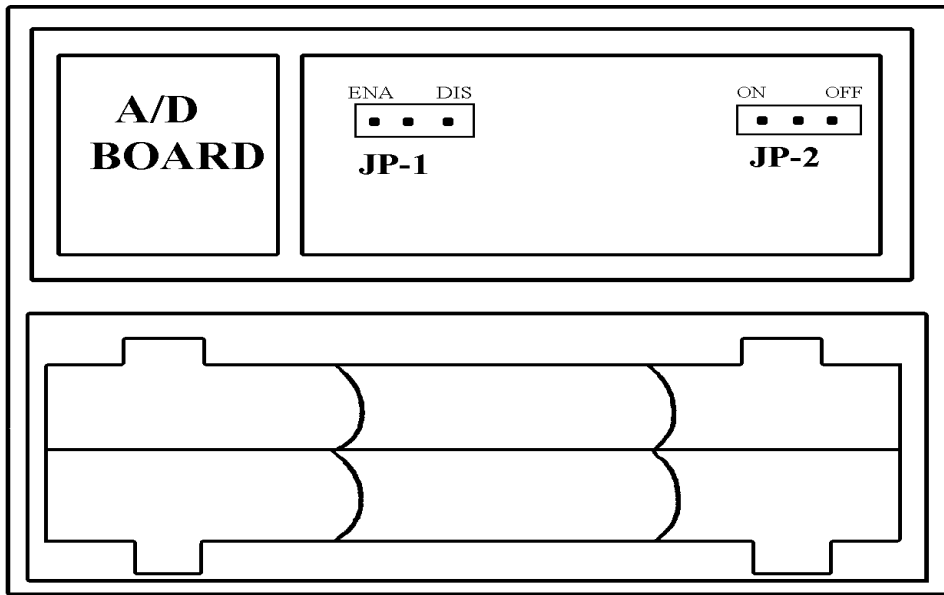

Calibration Jumper

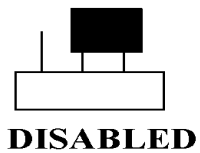
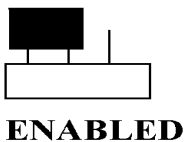

JP-1

Charging Circuit Jumper (for Ni-Cad)

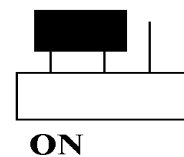
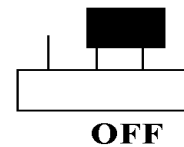

JP-2

Options (continued)

Interface

- **7.2. SETPOINT Interface**

4 setpoint signal can be output through Setpoint connector

- Method: 24V Open Drain CMOS
- 4 Setpoint Signal Output

- **7.3. Hardware Options**

- **7.3.1.1. Pole set for DI-10/28 series**

Standard pole used with DIGI Platform

Scales. The height of stainless steel pole is 33 in.

- **7.3.2. Mount Bracket Set for DI-28**

The kit is for any one of the following mounting options, desk-top, wall mount, DI- pole kit.

- **7.4. RS-232C Interface**

RS-232C serial data output. (Mini DIN 8 PIN)

The data transaction method can be set for continuous output, manual (by key entry), or command(Inquiry from an external device).

- **Protocol**

Baud Rate: 1200/ 2400/ 4800/ 9600/ 19200

Start Bit: 1 bit

Stop Bit: 1/ 2 bit

Data Bit: 7/ 8 bit

Parity Bit: Even/ Odd/ None

- **Text Command**

CR (0DH) The end of data

LF (0AH) The end of text

0 - 9 (30H-39H) Numeric data

- (2DH) Minus

. (2EH) Decimal Point

STX (02H) Start of Text

SOH (01H) Weight stable flag

NUL (00H) Weight un-stable flag

Options (continued)

7.2.1 Set Point Connection

7.2.1.1. Connector Configuration

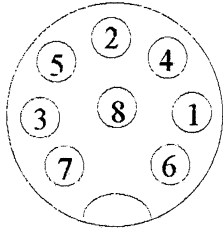

Set point	Pin
1	3
2	4
3	5
4	6
*Vcc	8
GND	1 & 2

* When Pin 8 of CN 2 on the main board is shorted to Vcc.

8 Pin DIN Plug (Front view)

An external voltage is needed to drive the devices like relays or LEDs. The external voltage can go up to a max. 30V DC depending on the device requirements, or a Vcc voltage, 5V DC, can be used on PIN 8 as an external voltage.

7.2.2. Spec Setting

SPEC 52 Bit 0 Set point control

0 Disable 1 Enable

SPEC 52 Bit 1 Set point output

0 Active high 1 Active low

7.2.3. How Set Points Work

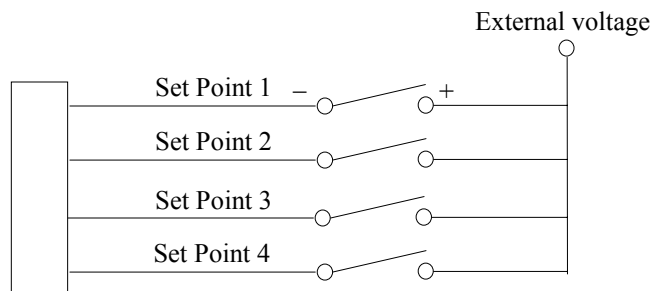

The state where no set point is reached.

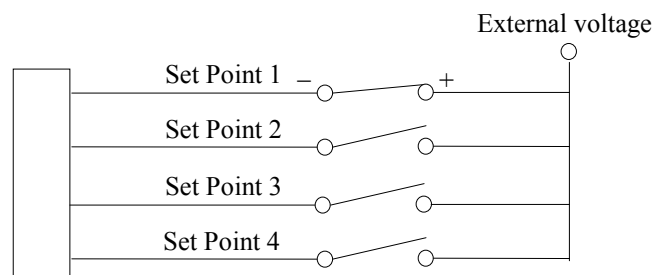

When set point 1 is reached, the relay at set point 1 will be on (eg. 1 kg.)

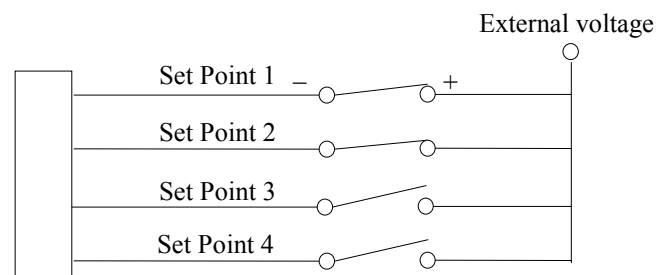

When set point 2 is reached, the relays at set point 1 and set point 2 will be on (eg. 1 kg and 2 kg.)

Options (continued)

7.4.1 RS232C Connection

7.4.1.1. Wire Configuration

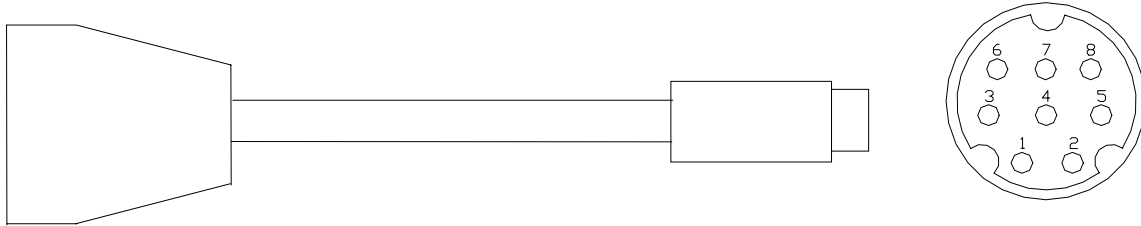

9 PIN D-SUB (FEMALE)

PC

Signal	Pin
RXD	2
TXD	3
GND	5
DTR	4
DSR	6
RTS	7
CTS	8

8 PIN MINI DIN (MALE)

DI 28

Pin	Signal
2	TXD
4	RXD
8	GND

25 PIN D-SUB (FEMALE)

PC

Signal	Pin
RXD	3
TXD	2
GND	7
RTS	4
CTS	5
DSR	6
DTR	20

8 PIN MINI DIN (MALE)

DI 28

Pin	Signal
2	TXD
4	RXD
8	GND

7.4.2. RS232C Configuration

Baud rate : 1200 / 2400 / 4800 / 9600 / 19200 bps
 Data bit : 7 bits or 8 bits
 Parity bit : None / Odd / Even
 Stop bit : 1 bit or 2 bits

Options (continued)

7.4.3. Spec Setting

SPEC 52 Bit 2		Send STX before text		
0	No	1	Yes	
SPEC 52 Bit 3		Handshaking for RS232 output		
0	No	1	Yes	
SPEC 53 Bit 0		Send Header as text		
0	No	1	Yes	
SPEC 53 Bit 1		RS232C data sending method		
0	Send immediately	1	After data is stable	
SPEC 53 Bit 2		RS232 data format		
0	Without header	1	With header	
SPEC 53 Bit 3		Stable flag in RS232C		
0	Without stable flag	1	With stable flag	
SPEC 54 Bit 0, 1 and 2		RS232C baud rate		
0 0 0	1200	0 1 0	4800	1 0 0 19200
0 0 1	2400	0 1 1	9600	
SPEC 54 Bit 3		RS232C output		
0	Disable	1	Enable	
SPEC 55 Bit 0		RS232C data length		
0	7 bit	1	8 bit	
SPEC 55 Bit 1		RS232C stop bit		
0	1 bit	1	2 bits	
SPEC 55 Bit 2 and 3		RS232C parity bit		
0 0	No parity	0 1	Odd	1 0 Even
SPEC 59 Bit 0 and 1		RS232C time out error		
0 0	1 sec	1 0	5 sec	
0 1	3 sec	1 1	10 sec	
SPEC 59 Bit 2		Stream / Manual method		
0	Stream	1	Manual	
SPEC 59 Bit 3		Remote trigger for RS232C		
0	Disable	1	Enable	

Options (continued)

7.4.4. RS-232 Communication Protocols

7.4.4.1. Text Format

STX*	Stable flag	CR	*Header	Net weight	CR	*Header	Tare weight	CR	LF
1	1	1	1	7	1	1	7	1	1

* Options set in Spec.

Stable Flag

*** Header**

(Send as code or text depend on SPEC 53 bit 0)

Stable flag	Data
Stable	SOH (01H)
Unstable	NUL (00H)

Header	As Code	As Text
Net weight	0 (30H)	NET WEIGHT :
Tare	4 (34H)	TARE WEIGHT :

Text

Text	Data
0 ~ 9	30H ~ 39H
.	2EH
,	2CH
-	2DH

Example: Net Weight = - 1.20 lb. Tare Weight = 0.45lb.

(a) Header Send As Code

STX	SOH	CR	0	-	0	1	.	2	3	0	CR	4	0	0	0	.	4	5	0	CR	LF
-----	-----	----	---	---	---	---	---	---	---	---	----	---	---	---	---	---	---	---	---	----	----

(a) Header Send As Text

STX	SOH	CR	N	-	0	1	.	2	3	0	CR	T	0	0	0	.	4	5	0	CR	LF
			E									A									
			T									R									
			W									E									
			E									I									
			I									G									
			G									H									
			H									T									
			T									:									

NOTE:

- ☞ Net Weight and Tare Weight excluding a sign are transmitted shifting to the right.
- ☞ When it is minus data (0x2D) or plus data (0x30), net and tare weight data are transmitted setting 2DH or 30H into the left most byte of each 7 byte data block.
- ☞ In case of over weight, the data will transmitted as follows:
0 OV 00000 CR 4??????? CR LF
- ☞ Decimal points are transmitted as[,] comma 0x2C or [.] Period 0x2E (See Spec 01 bit 3)

Options (continued)

7.4.5. Communication Method

There are three methods of sending the data :

- i) Stream
- Send the data immediately
- ii) Manual
- Send the data when [↑] is pressed using handshaking or no handshaking protocol.
- iii) Command
- Send data when ACK code is received from remote system using handshaking or no handshaking protocol.

i) Stream method (SPEC 59 Bit 2 is 0)

This method will sending the data immediately.

PC

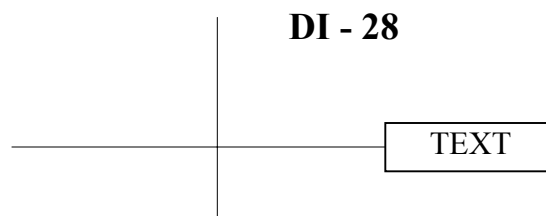

ii) Manual method (SPEC 59 Bit 2 is 1)

No handshaking (SEPC 52 bit 3 is 0)

Press [↑] key to send data.

PC

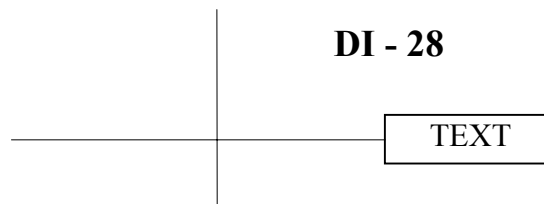

Options (continued)

With handshaking (SPEC 52 bit 3 is 1)

Press [↑] key to send data

PC / DP - 122

DI - 28

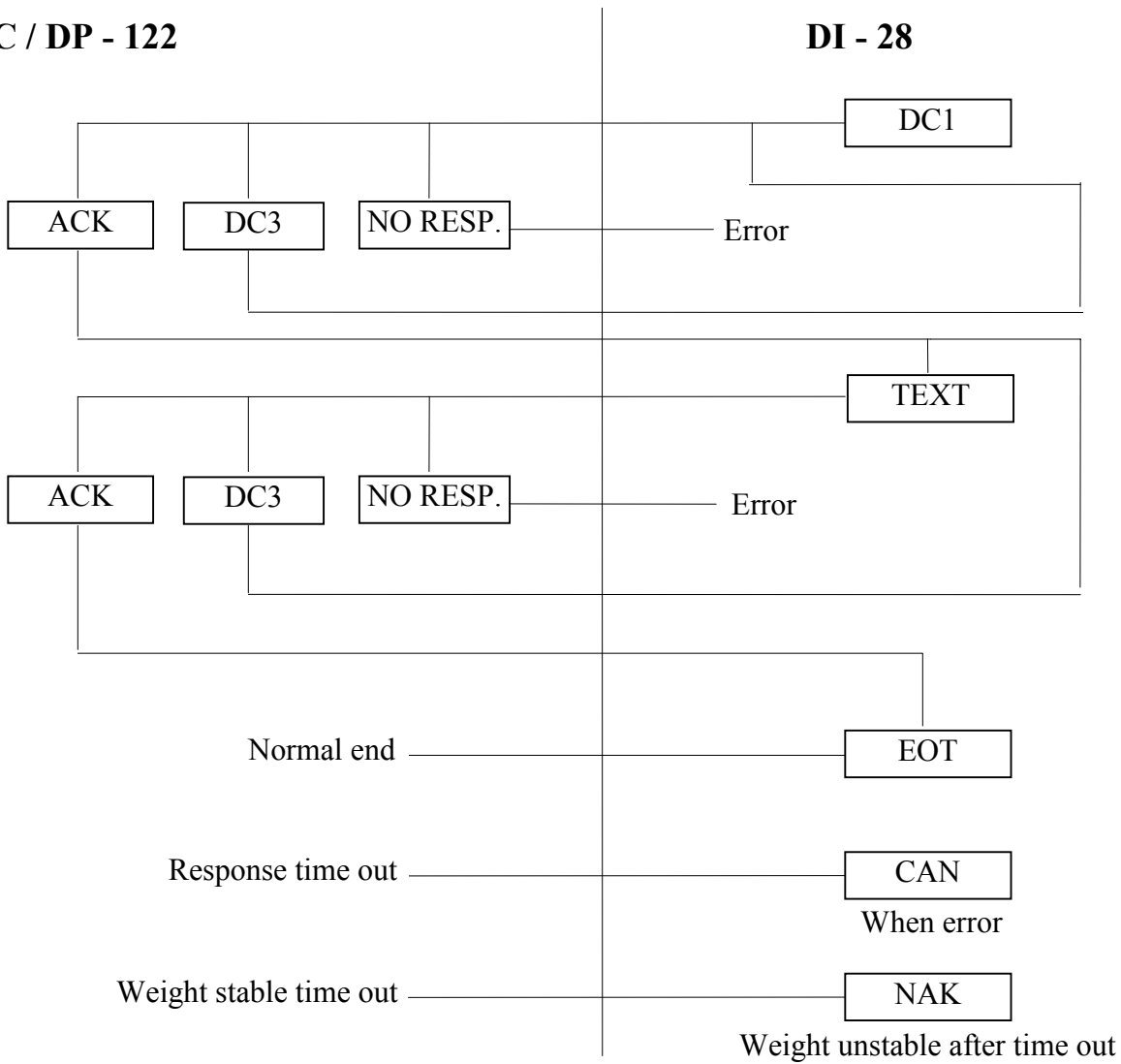

iii) Command Method (SPEC 59 Bit 3 is 1)

No handshaking (SPEC 52 bit 3 is 0)

PC

DI - 28

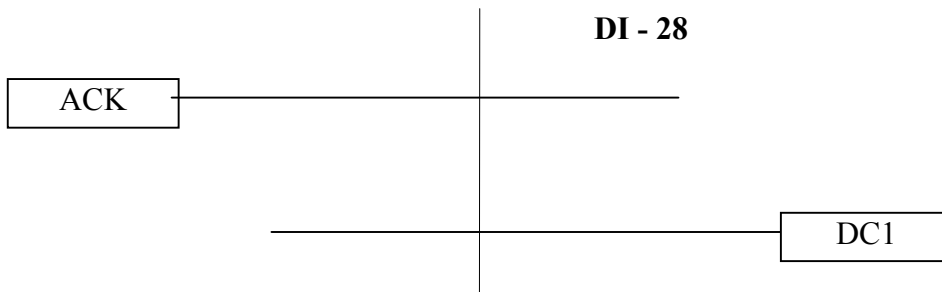

Options (continued)

With handshaking (SPEC 52 bit 3 is 1)

PC / DP 122

DI - 28

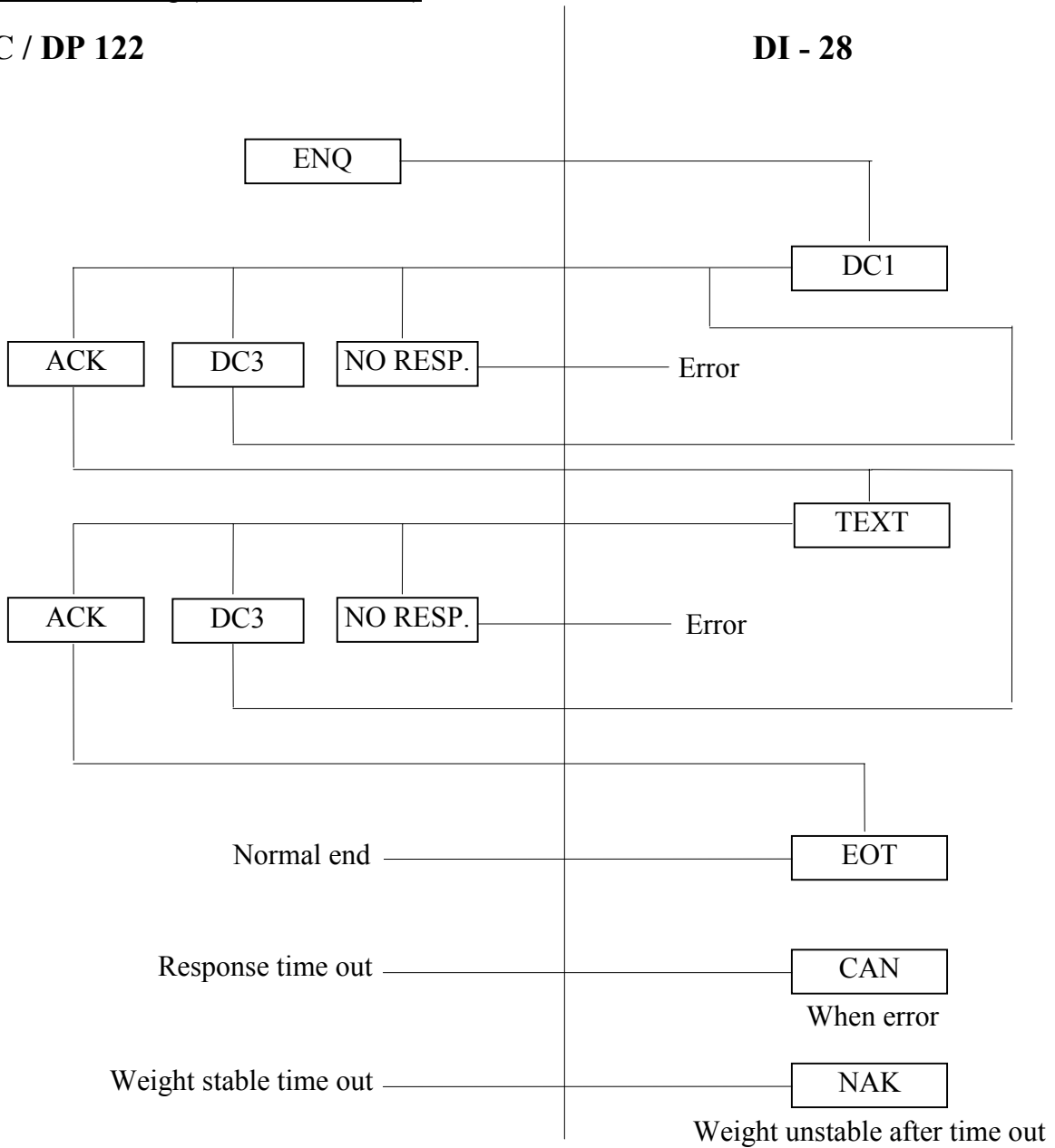

8.0. MAINTENANCE, CALIBRATION, TEST PROCEDURE & SERVICE

This section contains information and instructions concerning maintenance of the DI-28 weighing indicator.

Preventive maintenance consists of periodically cleaning the external surfaces of the instrument and should be performed as often as operating conditions warrant.

The calibration procedure is designed to be an aid in maintaining the scale accuracy within specifications. The calibration procedure may also serve as a performance test procedure.

CAUTION: DO NOT ATTEMPT ANY SERVICE WHILE THE INSTRUMENT IS CONNECTED TO THE POWER LINES.

8.1. Maintenance Procedures

8.1.1. Exterior Maintenance

The exterior surfaces of the weighing scale can be easily cleaned using soap and water. However, extreme caution should be used so that there is no possibility of water penetration into the scale electrical or mechanical sections. A damp cloth or sponge is suggested. NEVER USE ACETONE, MEK, OR SIMILAR SOLVENTS ON THE PLASTIC HOUSING AS THEY WILL ETCH THESE SURFACES.

For grease or other difficult spots, a chlorothane or naphtha based cleaner may be used. Never use any solvents on the front or rear panels.

Accumulations of dust or dirt particles between the pins of the connectors may be removed by using dry forced air or a small dry brush.

8.1.2. Internal Maintenance

Internal maintenance is not normally required and if it is, should not be attempted except by a qualified, authorized service technician.

8.1.3. Calibration

The following procedure should be followed periodically (every six to twelve months is suggested) to determine that the scale is functioning in all modes.

- a. Electrical
Follow section 4.0 through all its steps

8.1.3 Continued

b. **Accuracy**

Weighing: The scale weighing accuracy can be determined by applying various known weights to the platform. Because of the scale's very high accuracy, only weights that are certifiably more accurate than the scale's specifications should be used in testing for accuracy. (NBS class "F" or higher)

Since the scale owner does not normally have such certifiable weights available to him, it is suggested that the customer call their authorized DIGI dealer.

8.2. **Service & Repair**

No service or repair should be attempted except by qualified personnel, and not until it has been positively determined that the weighing scale requires such service. All service should be done in a clean, dry, dust-proof area.

8.3. **Load Cell Wiring**

Connector : Amphenol 14 Pin 57 Series Cable Connector (male)
Part # 57-30140

Pin Assignments

PIN #	FUNCTION
1	+ Sense
2	- Sense
3	+ Excitation
4	- Excitation
5	Shield
6	+ Signal
7	- Signal

14 PIN AMPHENOL FEMALE

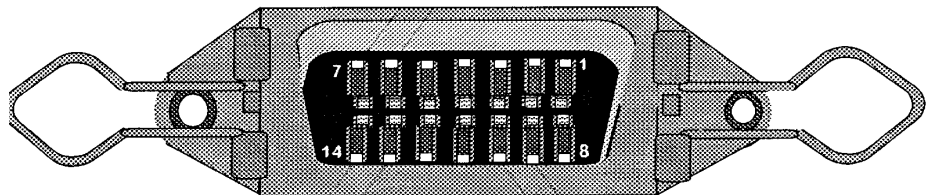

DI-28 Limited Warranty

Rice Lake Weighing Systems (RLWS) warrants that all RLWS equipment and systems properly installed by a Distributor or Original Equipment Manufacturer (OEM) will operate per written specifications as confirmed by the Distributor/OEM and accepted by RLWS. All systems and components are warranted against defects in materials and workmanship for one year.

RLWS warrants that the equipment sold hereunder will conform to the current written specifications authorized by RLWS. RLWS warrants the equipment against faulty workmanship and defective materials. If any equipment fails to conform to these warranties, RLWS will, at its option, repair or replace such goods returned within the warranty period subject to the following conditions:

- Upon discovery by Buyer of such nonconformity, RLWS will be given prompt written notice with a detailed explanation of the alleged deficiencies.
- Individual electronic components returned to RLWS for warranty purposes must be packaged to prevent electrostatic discharge (ESD) damage in shipment. Packaging requirements are listed in a publication, "Protecting Your Components From Static Damage in Shipment," available from RLWS Equipment Return Department.
- Examination of such equipment by RLWS confirms that the nonconformity actually exists, and was not caused by accident, misuse, neglect, alteration, improper installation, improper repair or improper testing; RLWS shall be the sole judge of all alleged non-conformities.
- Such equipment has not been modified, altered, or changed by any person other than RLWS or its duly authorized repair agents.
- RLWS will have a reasonable time to repair or replace the defective equipment. Buyer is responsible for shipping charges both ways.
- In no event will RLWS be responsible for travel time or on-location repairs, including assembly or disassembly of equipment, nor will RLWS be liable for the cost of any repairs made by others.

THESE WARRANTIES EXCLUDE ALL OTHER WARRANTIES, EXPRESSED OR IMPLIED, INCLUDING WITHOUT LIMITATION WARRANTIES OF MERCHANTABILITY OR FITNESS FOR A PARTICULAR PURPOSE. NEITHER RLWS NOR DISTRIBUTOR WILL, IN ANY EVENT, BE LIABLE FOR INCIDENTAL OR CONSEQUENTIAL DAMAGES.

RLWS AND BUYER AGREE THAT RLWS'S SOLE AND EXCLUSIVE LIABILITY HEREUNDER IS LIMITED TO REPAIR OR REPLACEMENT OF SUCH GOODS. IN ACCEPTING THIS WARRANTY, THE BUYER WAIVES ANY AND ALL OTHER CLAIMS TO WARRANTY.

SHOULD THE SELLER BE OTHER THAN RLWS, THE BUYER AGREES TO LOOK ONLY TO THE SELLER FOR WARRANTY CLAIMS.

No terms, conditions, understanding, or agreements purporting to modify the terms of this warranty shall have any legal effect unless made in writing and signed by a corporate officer of RLWS and the Buyer.

© 2002 Rice Lake Weighing Systems, Inc. Rice Lake, WI USA. All Rights Reserved.

RICE LAKE WEIGHING SYSTEMS • 230 WEST COLEMAN STREET • RICE LAKE, WISCONSIN 54868 • USA



230 W. Coleman St. • Rice Lake, WI 54868 • USA
U.S. 800-472-6703 • Canada/Mexico 800-321-6703
International 715-234-9171

www.ricelake.com
[mobile: m.ricelake.com](http://m.ricelake.com)

© 2011 Rice Lake Weighing Systems

PN 73356 01/2012