

# 1280 Enterprise™ Series Digital Load Cell

*RL5426DC and RL5416DC Configuration  
Firmware Version 2.05*

## Technical Manual



© Rice Lake Weighing Systems. All rights reserved.

Rice Lake Weighing Systems® is a registered trademark of  
Rice Lake Weighing Systems.

All other brand or product names within this publication are trademarks or  
registered trademarks of their respective companies.

All information contained within this publication is, to the best of our knowledge, complete and  
accurate at the time of publication. Rice Lake Weighing Systems reserves the right to make  
changes to the technology, features, specifications and design of the equipment without notice.

The most current version of this publication, software, firmware and all other product  
updates can be found on our website:

[www.ricelake.com](http://www.ricelake.com)

# Revision History

---

This section tracks and describes the current and previous manual revisions for awareness of major updates and when the updates took place.

Revision	Date	Description
A	May 12, 2022	Initial manual release with the launch of the product

*Table i. Revision Letter History*



Technical training seminars are available through Rice Lake Weighing Systems. Course descriptions and dates can be viewed at [www.ricelake.com/training](http://www.ricelake.com/training) or obtained by calling 715-234-9171 and asking for the training department.

# Contents

<b>1.0</b>	<b>Introduction</b>	<b>1</b>
1.1	Safety	1
1.2	Overview	2
1.2.1	Hardware	2
1.2.2	RS-485/Power Supply Card	2
1.2.3	1280 Indicator Configuration	2
1.2.4	Diagnostics	2
<b>2.0</b>	<b>Installation</b>	<b>3</b>
2.1	Installation Check List	3
2.2	Wiring and Configuration	3
2.3	Power considerations	4
2.4	Transient Protection	4
2.5	Cable Connections	4
2.5.1	Power	5
2.5.2	Communications	5
2.5.3	Water/Dust Tight Cord Grips	6
2.5.4	Shield Grounding Through Cord Grips	6
2.6	Replacement Parts	7
<b>3.0</b>	<b>1280 Configuration</b>	<b>8</b>
3.1	Manual Configuration Check List	8
3.2	RL5426DC/RL5416DC and 1280 Communication	8
3.2.1	Enter 1280 Configuration Mode	8
3.2.2	Configure 1280 Serial Port	8
3.2.3	Add 1280 Scale to Read RL5426DC/RL5416DC	9
3.3	Configure Digital Load Cells	10
3.3.1	Digital Load Cell Setup	10
3.3.2	Set Load Cell Addresses	11
3.3.3	Set Load Cell Assignments	11
3.3.4	Set Load Cell Capacity	12
3.4	Calibrate the Scale	12
3.4.1	Perform Standard Calibration	12
3.4.2	Calibrate by Section Match	14
3.4.3	Calibrate by Corner Match	15
3.4.4	Adjustment Tweak Wizard	16
3.5	Diagnostics Information	18
3.5.1	Adjust Diagnostic Thresholds	19
3.5.2	Add Diagnostics Softkey	20
3.6	Alert History	21
3.7	EDP Commands	22
<b>4.0</b>	<b>Specifications</b>	<b>23</b>



Rice Lake continually offers web-based video training on a growing selection of product-related topics at no cost. Visit [www.ricelake.com/webinars](http://www.ricelake.com/webinars)

# 1.0 Introduction

This manual is intended for use by service technicians responsible for installing and servicing RL5426DC/RL5416DC digital load cells. Digital Load Cell scales are a feature that was added into 1280 firmware version 2.05. This manual applies to firmware Version 2.05 or later.



Manuals and additional resources are available from the Rice Lake Weighing Systems website at [www.ricelake.com](http://www.ricelake.com)

Warranty information can be found on the website at [www.ricelake.com/warranties](http://www.ricelake.com/warranties)

## 1.1 Safety

### Safety Signal Definitions:



**DANGER** Indicates an imminently hazardous situation that, if not avoided, will result in death or serious injury. Includes hazards that are exposed when guards are removed.



**WARNING** Indicates a potentially hazardous situation that, if not avoided, could result in serious injury or death. Includes hazards that are exposed when guards are removed.



**CAUTION** Indicates a potentially hazardous situation that, if not avoided, could result in minor or moderate injury.



**IMPORTANT** Indicates information about procedures that, if not observed, could result in damage to equipment or corruption to and loss of data.

## General Safety



**Do not operate or work on this equipment unless this manual has been read and all instructions are understood. Failure to follow the instructions or heed the warnings could result in injury or death. Contact any Rice Lake Weighing Systems dealer for replacement manuals.**



**Failure to heed could result in serious injury or death.**

**Some procedures described in this manual require work inside the indicator enclosure. These procedures are to be performed by qualified service personnel only.**

**Do not allow minors (children) or inexperienced persons to install/operate this unit.**

**Do not operate without enclosure completely assembled.**

**Do not place fingers into slots or possible pinch points.**

**Do not use this product if any of the components are cracked.**

**Do not make alterations or modifications to the unit.**

**Do not remove or obscure warning labels.**

**Do not submerge.**

**Before opening the unit, ensure all power is disconnected.**

## 1.2 Overview

Digital load cells communicate with the 1280 serially through an RS-485 interface. The 1280 indicator must be running firmware version 2.05 or greater. Digital Load Cell configuration will not be visible unless capability has been enabled. See your dealer representative for more information.

**IMPORTANT**

*To enable Digital Load Cell configuration capability, send serial EDP command **DLCENABLE=ON** to the 1280 indicator.*

### 1.2.1 Hardware

The digital load cells can be connected to one of the on-board RS-485 ports or to the Serial option card RS-485 port. The 1280 indicator can have up to 32 load cells which can be assigned to multiple scales. There is a maximum of 16 load cells assigned to a single scale. A 1280 serial port supports a single scale.

### 1.2.2 RS-485/Power Supply Card

There is a RS-485/Power Supply card between the serial port and the scale. The card also supplies the power supply connection to the digital load cells. The digital load cells are powered with 15 VDC. The power supply has a 15 VDC output and can be connected with 100-240 VAC.

### 1.2.3 1280 Indicator Configuration

The digital load cells are configured in the 1280 indicator as one or more scales. These scales are calibrated in the Calibration Wizard using Standard Calibration ([Section 3.4.1 on page 12](#)), Section Match ([Section 3.4.2 on page 14](#)), or Corner Match ([Section 3.4.3 on page 15](#)). Once Calibrated, the scale reading can be tweaked using the Adjustment Tweak Wizard ([Section 3.4.4 on page 16](#)).

### 1.2.4 Diagnostics

The 1280 automatically logs load cell connection error and over or under-load errors. Depending on the specific scale application, the 1280 can be configured to return the following additional diagnostics errors ([Section 3.5.1 on page 19](#)):

- Zero reference
- Drift
- Noise
- Unbalance

Diagnostic information can be viewed by adding a diagnostics softkey to the 1280 screen ([Section 3.5.2 on page 20](#)) or via the fly-out menu. Errors are logged in the alert history and can be viewed on the 1280 ([Section 3.6 on page 21](#)).

## 2.0 Installation

This section describes procedures for connecting load cell, power and serial communications cables to the 1280 Indicator.



**WARNING**

*Some procedures described in this manual require work inside the indicator enclosure. These procedures are to be performed by qualified service personnel only.*

*Before opening the unit, ensure all power is disconnected.*

*Use a wrist strap for grounding and protection of components from electrostatic discharge (ESD) when working inside the indicator.*

### 2.1 Installation Check List

The following check list should be followed to ensure that the digital load cells are fully prepared to be connected to a 1280 indicator.



**Note**

*All cords must be properly grounded (See [Section 2.5.4 on page 6](#)).*

#### Minimum Requirements

The RL5426DC/RL5416DC will not communicate with the 1280 indicator unless the following wiring has been installed:

- \_\_\_ Connect load cells (See [Section 2.2](#))
- \_\_\_ Connect serial communication (See [Section 2.5 on page 4](#))

### 2.2 Wiring and Configuration

A 1280 indicator can support up to 16 digital load cells.

[Figure 2-1](#) shows the wiring for multiple digital load cells. Load cells must first be configured individually using the 1280 to assign load cell addresses ([Section 3.3.2 on page 11](#)), then load cells must be wired consecutively. The graphic representation of the load cell arrangement below assumes locations for each load cell. Load cells can be renamed during configuration, but the address cannot be changed. While load cells can be arranged in any formation, platforms defined as paired sections (truck scale applications) must be correctly associated in pairs to ensure valid calibration and diagnostic functions.

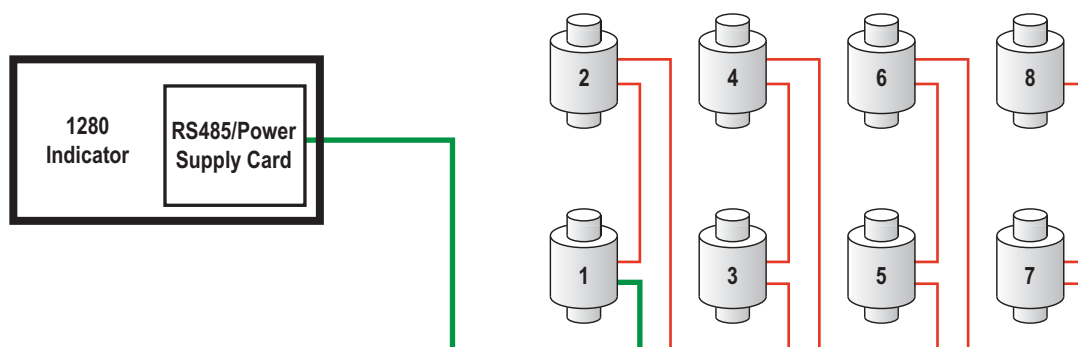

Figure 2-1. Load Cell Arrangement Wiring

## 2.3 Power considerations

The power supply is 15 VDC, 25 Watt, maximum output 1.75 A. Full load operating range is -20°C to 50°C (-4°F to 122°F). Typical input current for one RL5426DC/RL5416DC is 35 mA.

## 2.4 Transient Protection

For the RL5426DC/RL5416DC cable, the shield connects to the RS-485/Power Supply card.

**IMPORTANT**

*Improper grounding of systems can cause costly lightning damage to electronics. Always strive for a single-point grounded system. Refer to the product manual for proper grounding techniques.*

Figure 2-2 illustrates a generic single-point grounded system.

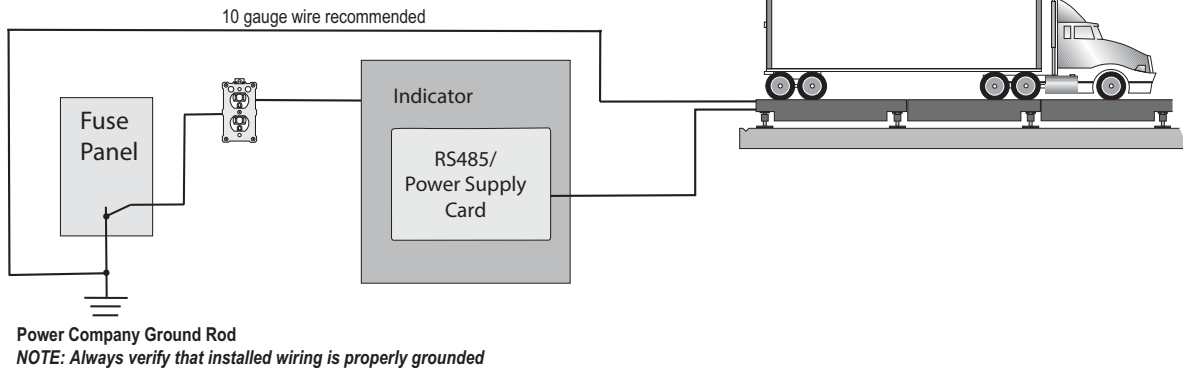

Figure 2-2. Truck Scale Single-Point Grounding Example

## 2.5 Cable Connections

The RS-485/power interface cable runs from the load cell to CON 1 on the RS-485/Power Supply card. The A+ and B- ports of CON2 are connected to serial port J6 of the 1280 CPU board. The +VCC and GND ports of CON2 are connected to the digital load cell power supply.



Figure 2-3. Wiring to RS-485/Power Supply Card



**Shield from the digital load cell cable connects to CON1 of the RS-485/Power Supply card or is grounded to the enclosure at the metal cord grip (Section 2.5.4 on page 6).**

**The power supply card must be grounded to the 1280 grounding stud per national electrical code (NEC).**

### 2.5.1 Power

Power runs from the power source to the power supply to CON2 on the RS-485 interface and power supply card.

100-240VAC	PS (IN)	PS (OUT)	VDC	Color	CON2
Black	PS-5	PS-1	+15V	White	VCC
Blue	PS-4	PS-2	-15V	Brown	GND

Table 2-1. Digital Load Cell Power Cables

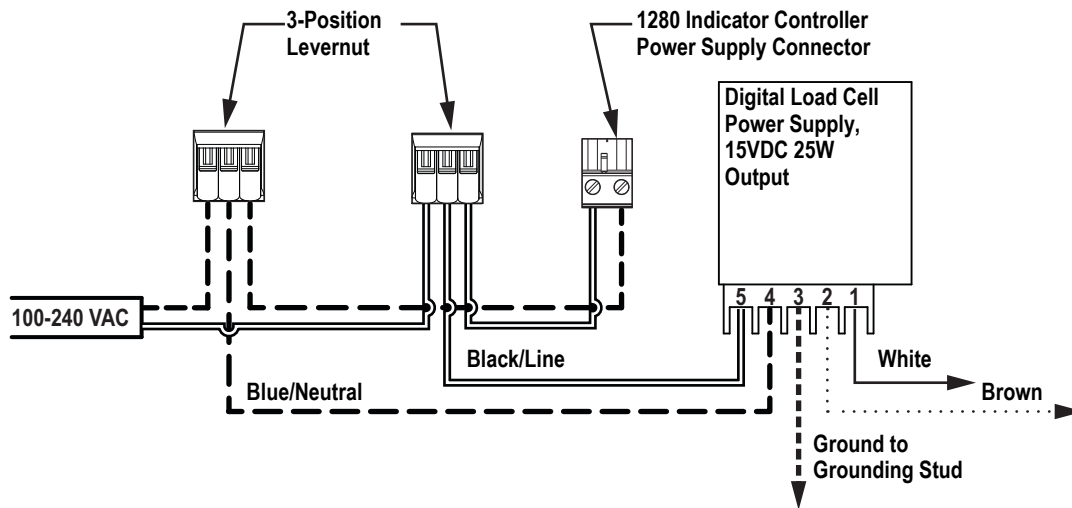

Figure 2-4. Wiring to Power Supply



**Note** All wires must be zip tied together to meet UL standards  
The power supply card must be grounded to the 1280 grounding stud per national electrical code (NEC).

### 2.5.2 Communications

The RL5426DC/RL5416DC communication wires can be connected to the 1280 either via the RS-485/Power Supply card or to a serial option card.

RS-485 from DLC	CON1	CON2	Color	1280 Serial Port
Shield	Shield	--	--	--
Green	A+	A+	Green	J6-2
White	B-	B-	Yellow	J6-3

Table 2-2. Digital Load Cell RS-485 cable

To attach serial communications cables, route the cable RL5426DC/RL5416DC through the cord grip and wire to CON 1 on the RS-485/Power Supply card. Connect wires from CON2 to a serial port on the 1280.

#### Communications Cable Distance Limitations

The maximum cable lengths that can be used for the communication types depend on several factors.

- Output impedance of the transmitter
- Electrical noise in the environment
- Cable capacity, wire gauge, termination, shielding and baud rates

Use the recommendation in [Table 2-3](#) as a general guide for communication cabling.

Cable Type	Distance
RS-485	1,500' (500 m) twisted pair cable @ 19,200 Baud

Table 2-3. Communication Cable Limitation

### 2.5.3 Water/Dust Tight Cord Grips

The standard cord grip has a black bushing that clamps down on the cable. If cord grip does not run a cable, then add the optional post plug to maintain the IP seal.

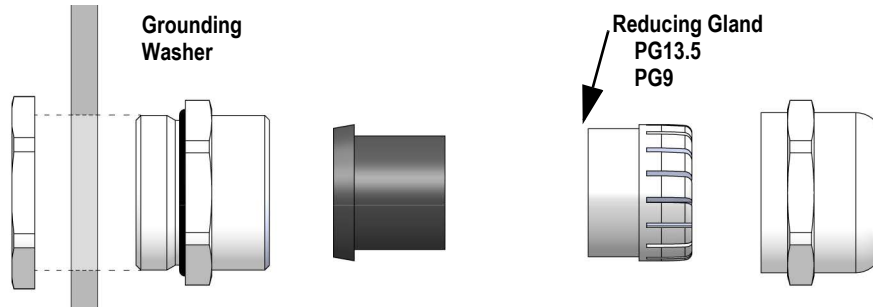

Figure 2-5. Cord Grip with Reducing Gland

Replace the bushing with a reducing gland to accommodate a smaller diameter cable. The reducing gland will allow the cord grip to maintain as much water/dust tightness as possible. Install the reducing gland in the top section of the cord grip in place of the bushing.

Cord Grip (PN)	Black Bushing	Reducing Gland (PN)	Reducing Gland Diameter
PG13.5 (169876)	0.264-0.472 in (6.7-12 mm)	PG13.5 (195006)	0.157-0.354 in (4-9 mm)
PG9 (169875)	0.157-0.314 in (4-8 mm)	PG9 (195007)	0.118-0.236 in (3-6 mm)

Table 2-4. Cord Grip and Reducing Gland Diameters

### 2.5.4 Shield Grounding Through Cord Grips

To ground cables to the 1280 universal or wall enclosures, route the cable through one of the metal cord grips. Ensure the exposed shielding makes contact with the tabs of the grounding washer inside the cord grip.

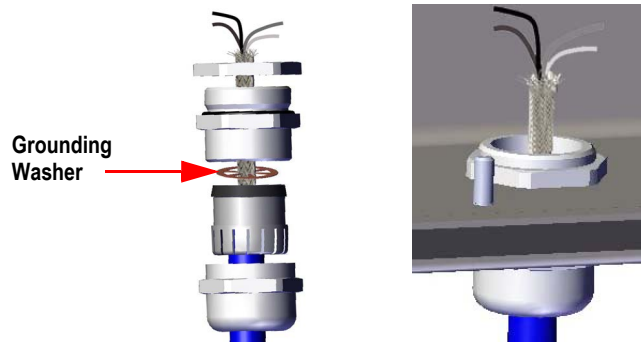

Figure 2-6. 1280 Universal and Wall Enclosure Grounding



**Ensure contact between the exposed shielding and the tabs of the grounding washer.**

**If the cable is grounded on CON1 at the RS-485/Power Supply card (Figure 2-3 on page 4), it is still a good practice to ground at the cord grip to keep radiated noise out of the enclosure.**

## 2.6 Replacement Parts

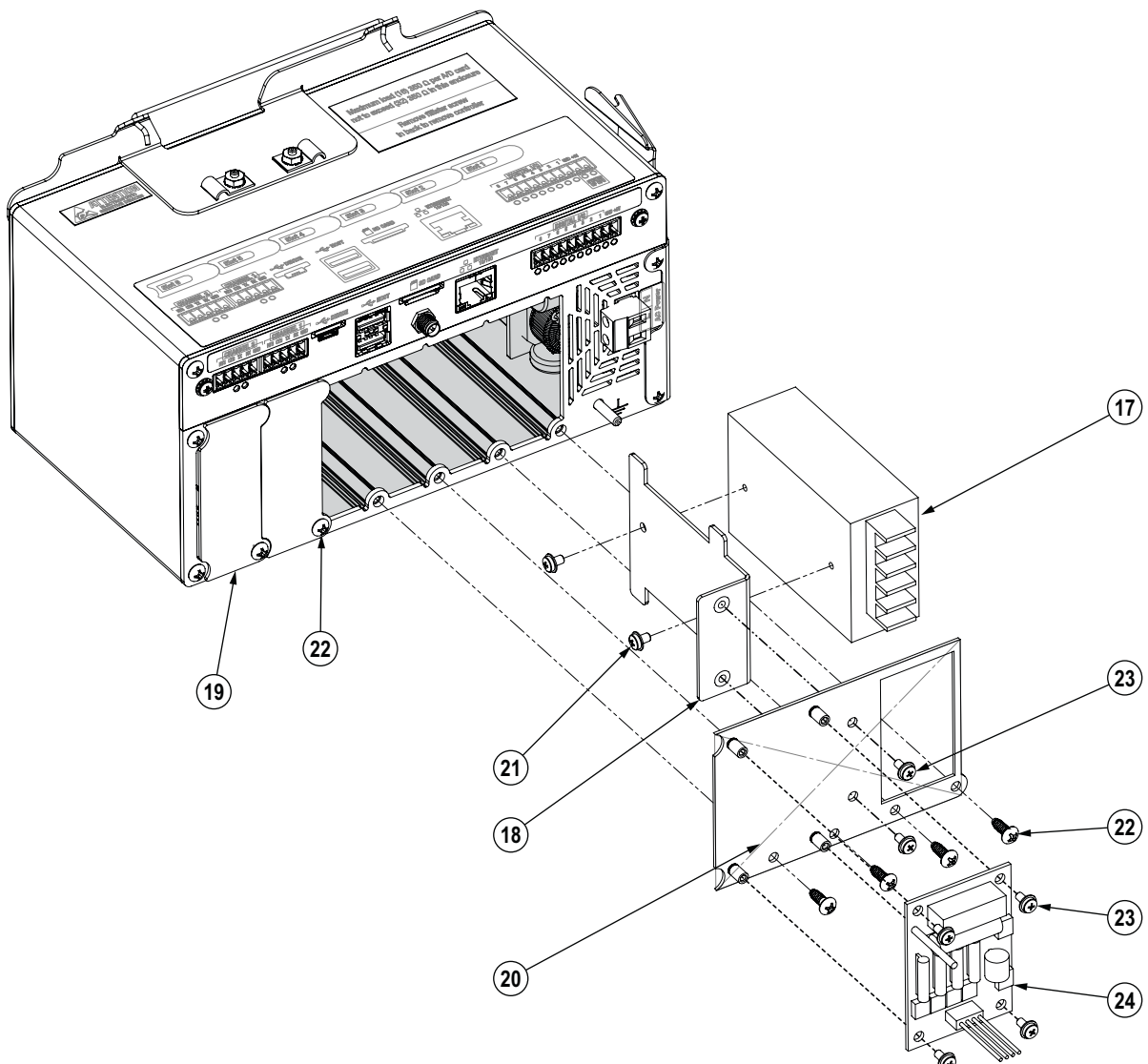

Figure 2-7. Digital Load Cell RS-485/Power Supply Card Parts Diagram (PN 206538)

Item No.	Part No.	Description	Qty.
17	207447	Power Supply, 15VDC 25W Input Voltage 90 to 264VAC Auto Switching	1
18	209433	Mount,Power Supply	1
19	163408	Blank Plate, Empty Option Card Slot Cover	2
20	209434	Faceplate,DLC Board	1
21	199474	Screw,Metric M3x.5x5 S	2
22	163327	Screw,MACH 6-32NCx3/8	6
23	14822	Screw,Mach 4-40 NCx1/4	6
24	207446	DLC Interface RS485 and Power Card for Digital Load Cell Interface	1

Table 2-5. Digital Load Cell RS-485/Power Supply Card Parts List (PN 206538)

## 3.0 1280 Configuration

This section describes configuration for digital load cells using the 1280. Configuration success depends on performing the setup procedures in the specified order.

Before configuring the 1280 indicator, the load cell must be correctly connected. See [Section 2.0 on page 3](#) for installation and wiring check lists.

### IMPORTANT

**Digital Load Cell configuration will not be visible unless capability has been enabled. To enable Digital Load Cell configuration capability, send serial EDP command `DLCENABLE=ON` to the 1280 indicator. The indicator will power cycle automatically.**

### 3.1 Manual Configuration Check List



- \_\_\_ Configure the 1280 serial port to communicate with the RL5426DC/RL5416DC ([Section 3.2.2](#))
- \_\_\_ Add 1280 scale to read the RL5426DC/RL5416DC ([Section 3.2.3 on page 9](#))
- \_\_\_ Configure Digital Load Cells ([Section 3.3 on page 10](#))
- \_\_\_ Set Load Cell Assignments ([Section 3.3.3 on page 11](#))
- \_\_\_ Calibrate the Scale

### 3.2 RL5426DC/RL5416DC and 1280 Communication

Initial communication must be set up in order for the RL5426DC/RL5416DC to communicate with the 1280 indicator.

#### 3.2.1 Enter 1280 Configuration Mode

All instructions in this section originate in the 1280 configuration mode. To enter configuration mode:

1. Press  on the weigh mode screen. The **Main Menu** displays.
2. Press  **Configuration** to access the Configuration menu.

#### 3.2.2 Configure 1280 Serial Port

Use the following steps to configure the 1280 serial port to communicate with the load cell.

### IMPORTANT

**Ensure all custom configuration files have been installed before setting up Digital Load Cells. Downloading any custom configuration file, whether new or built-in, will delete all settings and replace them with the values in the configuration file. All calibration and configuration data will be erased when custom configuration file is downloaded.**

**Digital Load Cells only support a baud rate of 19,200.**

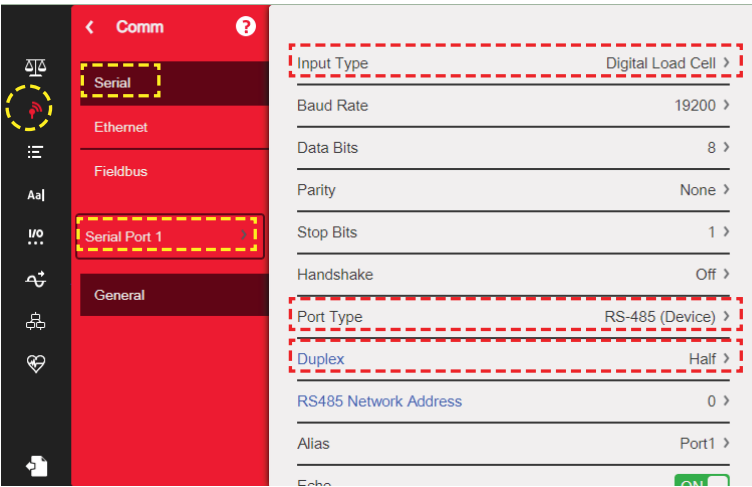

1. Press  to enter the **Communication** menu.
2. Press **Input Type** then select **Digital Load Cell**.
3. Press .
4. Press **Port Type** then select **RS-485**.
5. Press .
6. Press **Duplex** then select **Half**.
7. Press .

 **Note** *Serial Port 1 is the default displayed menu choice. If the digital load cells are connected to a different serial port, select the Serial Port 1 drop-down menu then select the connected port from that drop-down menu. The selected port's configuration settings will be displayed to the right.*

### 3.2.3 Add 1280 Scale to Read RL5426DC/RL5416DC

The **Scales** menu allows the setup of parameters for the type of scale being used. Use the following steps to set up these parameters.



**Note** *Scale 1 is the default displayed menu choice. If the digital load cells are to be used as a different scale number, select the Scale 1 drop-down menu then select the desired from that drop-down menu. The selected scale's configuration settings will be displayed to the right. See the 1280 Technical Manual (PN 167659) for more information on scale setup.*



	<ol style="list-style-type: none"> <li>1. Press  to enter the <b>Scales</b> menu.</li> <li>2. Press the edit scale icon . The <b>Scale Kind</b> menu displays.</li> <li>3. Select <b>Digital Load Cell</b> to set as the scale kind.</li> <li>4. Select the Scale Hardware type.           <div data-bbox="914 604 1027 665" data-label="Image"></div> <p><b>Note</b> <i>The default Scale Hardware type reads as "Connection: Port 1". This refers to the connected serial port. This selection will vary if the digital load cells are connected to a different serial port.</i></p> </li> <li>5. Press . Digital load cell is set as Scale 1.</li> </ol>
	<ol style="list-style-type: none"> <li>6. Press  again. Scale Format parameters display.           <div data-bbox="914 1010 1027 1071" data-label="Image"></div> <p><b>Note</b> <i>See the 1280 Technical Manual (PN 167659) for more information on scale setup.</i></p> </li> </ol>

### 3.3 Configure Digital Load Cells

The following configuration steps must be done prior to calibrating the scales.

- \_\_\_ Set load cell addresses individually ([Section 3.3.2 on page 11](#))
- \_\_\_ Install load cells consecutively in a chain by their address number
- \_\_\_ Set load cell assignments ([Section 3.3.3 on page 11](#))
- \_\_\_ Set load cell capacity ([Section 3.3.4 on page 12](#))

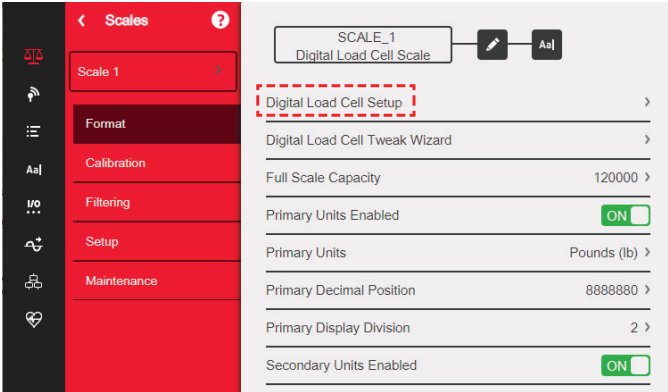
#### 3.3.1 Digital Load Cell Setup

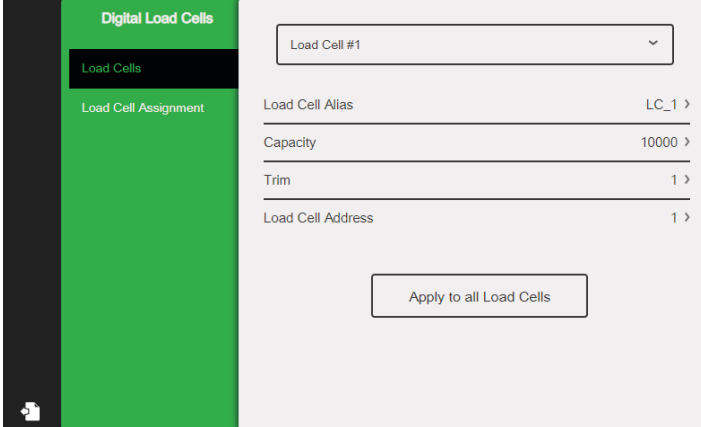

 <p>The screenshot shows the 'Scales' menu with 'Digital Load Cell Setup' highlighted in a red dashed box. The menu items are: Scale 1, Format, Calibration, Filtering, Setup, and Maintenance. The 'Digital Load Cell Setup' screen shows parameters for SCALE_1: Digital Load Cell Setup, Digital Load Cell Tweak Wizard, Full Scale Capacity (120000), Primary Units Enabled (ON), Primary Units (Pounds (lb)), Primary Decimal Position (8888880), Primary Display Division (2), and Secondary Units Enabled (ON).</p>	<ol style="list-style-type: none"> <li>1. Press  to enter the <b>Scales</b> menu.</li> <li>2. Select <b>Digital Load Cell Setup</b>. <b>Digital Load Cell Setup</b> menu displays.</li> </ol>
 <p>The screenshot shows the 'Digital Load Cells' menu with 'Load Cell Assignment' selected. The 'Load Cell #1' dropdown is set to 'Load Cell #1'. The parameters are: Load Cell Alias (LC_1), Capacity (10000), Trim (1), and Load Cell Address (1). An 'Apply to all Load Cells' button is at the bottom.</p>	<ol style="list-style-type: none"> <li>3. Select <b>Load Cell</b> drop-down menu to select load cell to configure.</li> </ol>

Parameter	Description
Alias	Enter desired name
Capacity	Enter the full capacity of the load cell
Trim	Decimal value is percentage of trim applied to the load cell; 1 is no trim value applied
Address	Address of load cell in sequence of connection

Table 3-1. Load Cell Parameters

### 3.3.2 Set Load Cell Addresses

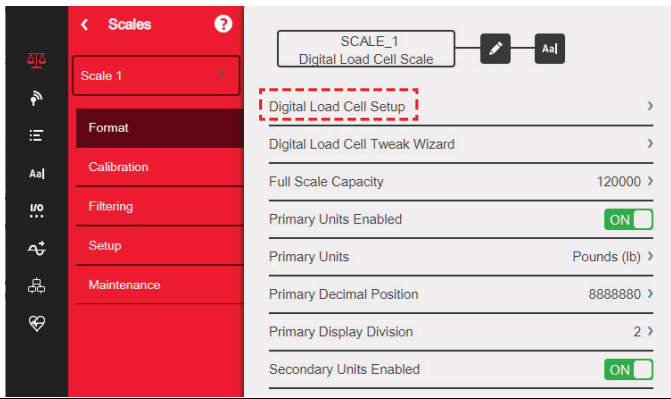
Load cell addresses must be assigned to each digital load cell individually before they are installed. The 1280 shows a load cell error if there are duplicate load cell addresses. Follow the instructions below on each digital load cell before installation. When replacing broken load cells, repeat this process on any new load cells before installation to replicate the address of the replaced load cell.

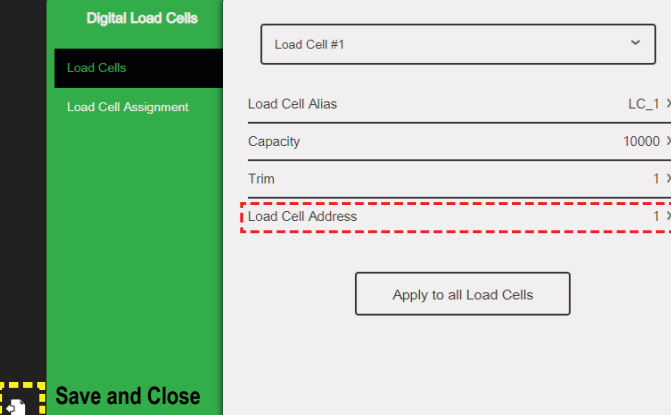
 <p>The screenshot shows the 'Scales' menu with 'Digital Load Cell Setup' highlighted in a red dashed box. The menu items are: Scale 1, Format, Calibration, Filtering, Setup, and Maintenance. The 'Digital Load Cell Setup' screen shows settings for SCALE_1: Digital Load Cell Scale, Digital Load Cell Tweak Wizard, Full Scale Capacity (120000), Primary Units Enabled (ON), Primary Units (Pounds (lb)), Primary Decimal Position (8888880), Primary Display Division (2), and Secondary Units Enabled (ON).</p>	<ol style="list-style-type: none"> <li>1. Attach an individual load cell to 1280 Indicator.</li> <li>2. Press  to enter the <b>Scales</b> menu from the configuration menu.</li> <li>3. Select <b>Digital Load Cell Setup</b>. <b>Digital Load Cell Setup</b> menu displays.</li> </ol>
 <p>The screenshot shows the 'Digital Load Cells' menu with 'Load Cell Assignment' highlighted in a red dashed box. The 'Load Cell Assignment' screen shows settings for Load Cell #1: Load Cell Alias (LC_1), Capacity (10000), Trim (1), and Load Cell Address (1). An 'Apply to all Load Cells' button is at the bottom. A 'Save and Close' button is at the bottom left.</p>	<ol style="list-style-type: none"> <li>4. Select <b>Load Cell Address</b>.</li> <li>5. Enter the address of the load cell.</li> <li>6. Press <b>Done</b>.</li> <li>7. Repeat <a href="#">Section 3.3.2</a> for all load cells.</li> </ol>

### 3.3.3 Set Load Cell Assignments

To apply and manually adjust the position of a RL5426DC/RL5416DC, use **Load Cell Assignments**.

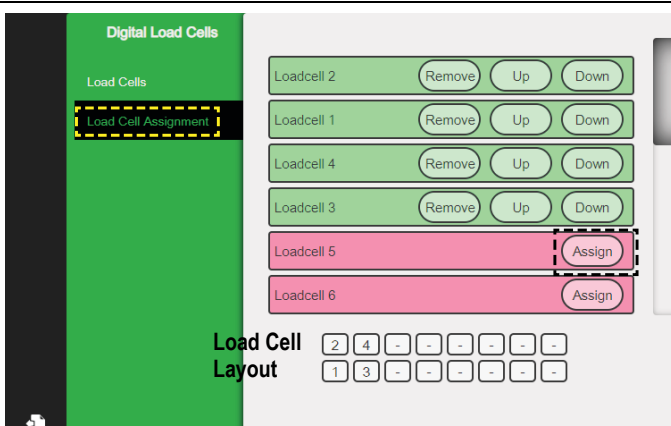
 <p>The screenshot shows the 'Load Cell Assignment' screen with 'Load Cell Assignment' highlighted in a red dashed box. The screen displays a list of load cells (Loadcell 2 through Loadcell 6) with 'Remove', 'Up', and 'Down' buttons. Loadcell 5 and Loadcell 6 are highlighted in pink and have 'Assign' buttons. Below the list is a 'Load Cell Layout' grid with buttons for 2, 4, 1, 3, and several '-' buttons.</p>	<ol style="list-style-type: none"> <li>1. Select <b>Load Cell Assignments</b>. <ul style="list-style-type: none"> <li>• Press <b>Assign</b> for each RL5426DC/RL5416DC in scale.</li> <li>• Press <b>Up</b> or <b>Down</b> to move the position of the load cell within the load cell layout.</li> <li>• Press <b>Remove</b> to remove the load cell from the load cell assignment.</li> </ul> </li> </ol>
---	--

### 3.3.4 Set Load Cell Capacity

Set load cell capacity in the Digital Load Cell setup menu.

	<ol style="list-style-type: none"> <li>1. Select <b>Load Cells</b>.</li> <li>2. Select <b>Capacity</b> and enter the load cell capacity using the numeric keypad.</li> <li>3. Press <b>DONE</b> after capacity is set.</li> <li>4. Press <b>Apply to All Load Cells</b>.</li> <li>5. Press <b>Back</b> to return to main setup menu.</li> </ol>
--	---

## 3.4 Calibrate the Scale

Each calibration completely overwrites any previous calibration settings. Initially, the calibration can be done as an Overall, Corner, Section or Theoretical calibration. Calibration can also be done for Last Zero, Temporary Zero, Multiple point. Besides using the calibration wizard, a manual trim can be performed in the Format menu for overall tweak, individual corner and section tweak (Section 3.4.4 on page 16).



**Calibration will establish Initial Zero, but going in and out of Configuration does not clear PB Zero. "SAVE TRIM VALUES" is not functional in 1280 firmware version 2.04.01.**

- \_\_\_ Perform standard calibration (Section 3.4.1)
- \_\_\_ Calibrate the scale by section match (Section 3.4.2 on page 14)
- \_\_\_ Calibrate the scale by corner match (Section 3.4.3 on page 15)



**See the 1280 Technical Manual (PN 167659) for more information on calibrating using Theoretical, Last Zero, Temporary Zero, and Multiple Point Calibration.**





### 3.4.1 Perform Standard Calibration

	<ol style="list-style-type: none"> <li>1. Enter the configuration menu and Select . The <b>Scales</b> menu displays.</li> <li>2. Select <b>Calibration</b> and press <b>Calibrate Scale</b>. <b>Digital Load Cell Scale Calibration</b> menu displays.</li> <li>3. Select <b>Standard Calibration</b> and press <b>Next</b>.</li> </ol>
--	---

<p><b>Digital Load Cell Scale Calibration</b></p> <p>Remove all test weights from the scale. Press Calibrate Zero to capture the zero calibration data.</p> <p style="text-align: center;"> <input type="button" value="Calibrate Zero"/> </p> <p>Current Weight: 0</p> <p style="text-align: right;"><input type="button" value="Expanded Resolution"/></p> <p>Zero Calibration Complete.</p> <p> <input type="button" value="Cancel"/> <input type="button" value=" &lt; Back"/> <input type="button" value=" Next &gt;"/> <input type="button" value=" Finish"/> </p>	<p>4. Remove all test weights from the scale. Press <b>Calibrate Zero</b> to capture the zero calibration data. <b>Zero Calibration Complete</b> displays when the indicator has captured zero.</p> <p>5. Press <b>Next</b>.</p>																					
<p><b>Digital Load Cell Scale Calibration</b></p> <p>Enter the calibration weight for the span calibration point and place the test weights on the scale. Press Calibrate Span to capture the span calibration data.</p> <p>Calibration Weight</p> <p>10000 <input type="button" value="123.."/></p> <p style="text-align: center;"> <input type="button" value="Calibrate Span"/> </p> <p>Current Weight: 10000</p> <p style="text-align: right;"><input type="button" value="Expanded Resolution"/></p> <p>Span Calibration Complete.</p> <p> <input type="button" value="Cancel"/> <input type="button" value=" &lt; Back"/> <input type="button" value=" Next &gt;"/> <input type="button" value=" Finish"/> </p>	<p>6. Enter the calibration weight for the test weight that will be used and press <input type="button" value="DONE"/> .</p> <p>7. Press <b>Next</b>.</p> <p>8. Put the calibration weight over current section.</p> <p>9. Press <b>Calibrate Span</b>. Span calibration completes.</p>																					
<p><b>Calibrate Scale</b></p> <p>Calibration Results</p> <table border="1"> <thead> <tr> <th></th> <th>Counts</th> <th>Data</th> </tr> </thead> <tbody> <tr> <td>Zero</td> <td>0</td> <td>0</td> </tr> <tr> <td>Span</td> <td>60000</td> <td>10000</td> </tr> <tr> <td>Linear Point 1</td> <td>0</td> <td>0</td> </tr> <tr> <td>Linear Point 2</td> <td>0</td> <td>0</td> </tr> <tr> <td>Linear Point 3</td> <td>0</td> <td>0</td> </tr> <tr> <td>Linear Point 4</td> <td>0</td> <td>0</td> </tr> </tbody> </table> <p> <input type="button" value="Cancel"/> <input type="button" value=" &lt; Back"/> <input type="button" value=" Next &gt;"/> <input type="button" value=" Finish"/> </p>		Counts	Data	Zero	0	0	Span	60000	10000	Linear Point 1	0	0	Linear Point 2	0	0	Linear Point 3	0	0	Linear Point 4	0	0	<p>10. Calibration results display.</p> <p> <b>Note</b> <i>Tweak Adjustments can be done after calibration. See <a href="#">Section 3.4.4</a> on page 16.</i></p> <p>11. Select <b>Finish</b> to Return to the Scale Setup.</p>
	Counts	Data																				
Zero	0	0																				
Span	60000	10000																				
Linear Point 1	0	0																				
Linear Point 2	0	0																				
Linear Point 3	0	0																				
Linear Point 4	0	0																				

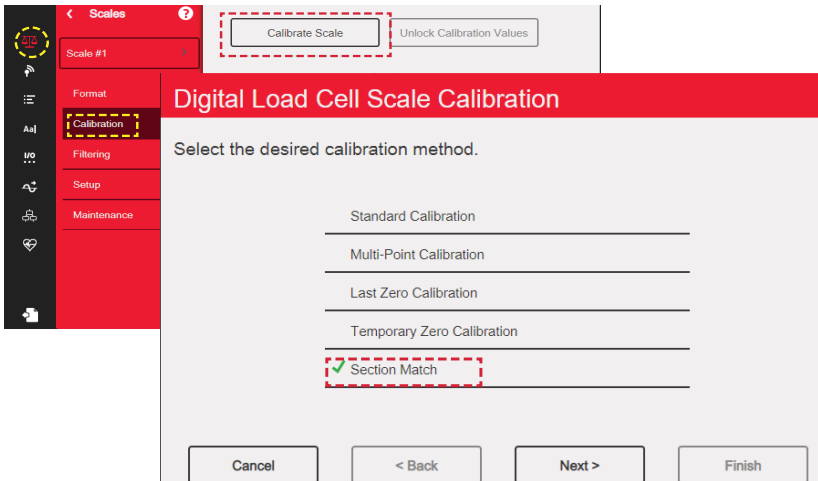
### 3.4.2 Calibrate by Section Match

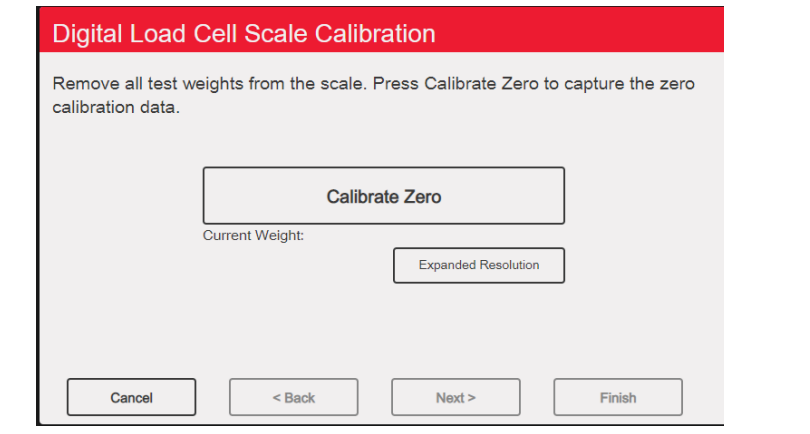
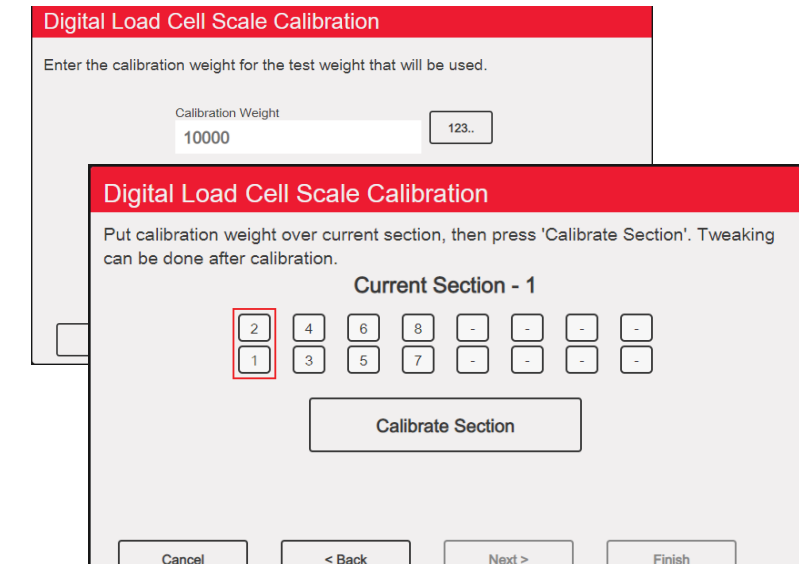
Use the following steps to calibrate the scale by Section Match.

	<ol style="list-style-type: none"> <li>1. Enter the configuration menu and select . The <b>Scales</b> menu displays.</li> <li>2. Select <b>Calibration</b> and press <b>Calibrate Scale</b>. <b>Digital Load Cell Scale Calibration</b> menu displays.</li> <li>3. Select <b>Section Match</b>.</li> <li>4. Press <b>Next</b>.</li> </ol>
	<ol style="list-style-type: none"> <li>5. Remove all test weights from the scale. Press <b>Calibrate Zero</b> to capture the zero calibration data. <b>Zero Calibration Complete</b> displays when the indicator has captured zero.</li> <li>6. Press <b>Next</b>.</li> </ol>
	<ol style="list-style-type: none"> <li>7. Enter the calibration weight for the test weight that will be used and press .</li> <li>8. Press <b>Next</b>.</li> <li>9. Put the calibration weight over current section.</li> <li>10. Press <b>Calibrate Section</b>. Section calibrates and the wizard proceeds to next section of the scale.</li> </ol>

Calibrate Scale		
Calibration Results		
	Counts	Data
Zero	0	0
Span	388768	10000
Linear Point 1	0	0
Linear Point 2	0	0
Linear Point 3	0	0
Linear Point 4	0	0
<input type="button" value="Cancel"/> <input type="button" value=" &lt; Back"/> <input type="button" value=" Next &gt;"/> <input type="button" value=" Finish"/>		

11. Repeat Steps 7 through 10 until all sections are calibrated. Press **Next**.



12. Calibration results display.

 **Note** *Tweaking can be done after calibration. See Section 3.4.4 on page 16.*

13. Select **Finish to Return to the Scale Setup**.

### 3.4.3 Calibrate by Corner Match

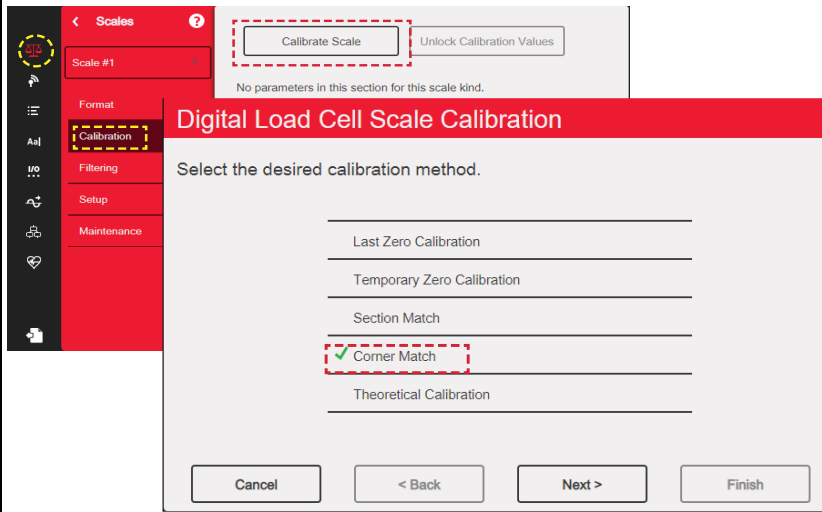
Use the following steps to calibrate the scale by Section Match.

 <p>Calibrate Scale    Unlock Calibration Values</p> <p>No parameters in this section for this scale kind.</p> <h3>Digital Load Cell Scale Calibration</h3> <p>Select the desired calibration method.</p> <p>_____</p> <p>Last Zero Calibration</p> <p>_____</p> <p>Temporary Zero Calibration</p> <p>_____</p> <p>Section Match</p> <p><input checked="" type="checkbox"/> Corner Match</p> <p>_____</p> <p>Theoretical Calibration</p> <p><input type="button" value="Cancel"/>    <input type="button" value=" &lt; Back"/>    <input type="button" value=" Next &gt;"/>    <input type="button" value=" Finish"/></p>	<ol style="list-style-type: none"> <li>1. Enter the configuration menu and select . The <b>Scales</b> menu displays.</li> <li>2. Select <b>Calibration</b> and select <b>Calibrate Scale. Digital Load Cell Scale Calibration</b> menu displays.</li> <li>3. Scroll down in the menu to select <b>Corner Match</b> and press <b>Next</b>.</li> </ol>
<h3>Digital Load Cell Scale Calibration</h3> <p>Remove all test weights from the scale. Press Calibrate Zero to capture the zero calibration data.</p> <p><input type="button" value="Calibrate Zero"/></p> <p>Current Weight: _____</p> <p><input type="button" value="Expanded Resolution"/></p> <p><input type="button" value="Cancel"/>    <input type="button" value=" &lt; Back"/>    <input type="button" value=" Next &gt;"/>    <input type="button" value=" Finish"/></p>	<ol style="list-style-type: none"> <li>4. Remove all test weights from the scale. Press <b>Calibrate Zero</b> to capture the zero calibration data. <b>Zero Calibration Complete</b> displays when the indicator has captured zero. Press <b>Next</b>.</li> </ol>

5. Enter the calibration weight for the test weight that will be used. Press **Next**.
6. Put calibration weight over corresponding corner. Press **Calibrate Corner**. Corner calibrates and wizard proceeds to next section.
7. Repeat Step 8 until all sections are calibrated. Press **Next**.
8. Select Finish to **Return to the scale Setup**.

**Note** *Tweaking can be done after calibration. See Section 3.4.4 on page 16.*

### 3.4.4 Adjustment Tweak Wizard

The Adjustment Tweak Wizard enables the load cells to be tweaked as a full scale, by section, or by corner. Follow the directions in the Adjustment Tweak Wizard to tweak the load cells.



**The calibration weight must be greater than the weigh of the contributing sections. Otherwise, the section will be set to zero and a recalibration is required.**

**Full, Section, or Corner trim can all be set/changed/adjusted without having to exit and save.**

**The displayed weight values use the initial calibrated zero and do not reflect the weight zeroed with a push button zero operation.**

1. Enter the configuration menu and Select . The **Scales** menu displays.
2. Select **Digital Load Cell Tweak Wizard**. Prompt displays to select desired tweak method. Select **Next**.
3. Follow directions in the Tweak Wizard.

### Digital Load Cell Tweak Wizard

Input desired total weight, then press Tweak. Current Weight must be at least 100 Grads.

Calibration Weight

0

123..

Calibrate Full Tweak

Current Weight: 9280

Press to enter calibration weight applied to the scale

Cancel < Back Next > Finish

### Full Tweak Wizard

1. Press **123..**.
2. Enter the calibration weight being applied to the scale. Default is 0.
3. Place Calibration weight on the scale.
4. Press **Calibrate Full Tweak**.

### Digital Load Cell Tweak Wizard

Select Section, then use the Adjust Buttons to adjust to desired weight. Scale Weight must be over 100 Grads and Section Weight cannot be 0.

#### Section Selection

2	4	6	8	-	-	-	-
1	3	5	7	-	-	-	-

Scale Weight - 5800  
Section Weight - 5800  
Calibration Weight -

Adjust Up

Adjust Down

Cancel < Back Next > Finish

### Section Tweak Wizard

Tap **Adjust up** or **Adjust Down** to increment the displayed value of the **Section Weight** until the **Scale Weight** displays the correct value.

### Digital Load Cell Tweak Wizard

Select Load Cell, then use the Adjust Buttons to adjust to desired weight. Scale Weight must be over 100 Grads and Load Cell Weight cannot be 0.

#### Load Cell Selection

2	4	6	8	-	-	-	-
1	3	5	7	-	-	-	-

Scale Weight - 2900  
Corner Weight - 2900  
Calibration Weight -

Adjust Up

Adjust Down

Cancel < Back Next > Finish

### Corner Tweak Wizard

Tap **Adjust up** or **Adjust Down** to increment the displayed value of the **Corner Weight** until the **Scale Weight** displays the correct value.

### 3.5 Diagnostics Information

An alarm message is displayed when an error is detected in a load cell. The 1280 will always report a **Cell Connection** error or an **Overload** error. Additional diagnostic alerts can be setup in the Scales Menu (Section 3.5.1 on page 19). Information on the load cells can be viewed in the Diagnostics screen below or as a return for an EDP command (Section 3.7 on page 22). The Alarm message and the Diagnostic screen will continue to show the error until the error state no longer exists.

	<p>An error code will be displayed at the bottom right corner of the screen when there is a load cell error.</p> <p>Click <b>Diagnostics</b> Softkey to display live diagnostics.</p> <p> <b>Note</b> To view a history of alerts, see Section 3.6 on page 21.</p>
	<p>Load cell in error will display as "failed" and load cell error will display at the bottom of the screen.</p>
	<p>Click on the failed cell to enable cell emulation.</p> <p> <b>Note</b> Scale with emulated load cell estimates load, but is not Legal for Trade.</p>



**A live diagnostic message for the scale is displayed at the bottom of the Diagnostics screen. The message will continue to show the error until the error state no longer exists. The diagnostic message is also populated in Alert History (Section 3.6 on page 21) and/or recorded to an error database.**

### 3.5.1 Adjust Diagnostic Thresholds

Diagnostic thresholds are adjusted in the Scales menu. For more information on diagnostic thresholds, see the 1280 Enterprise Series Technical Manual (PN 167659).

	Zero Reference	<input type="checkbox"/> OFF
	Zero Reference Range (lb)	1000 >
	Zero Reference Threshold (lb)	10000 >
	Zero Reference Time	10 >
	Drift	<input type="checkbox"/> OFF
	Drift Range (lb)	200 >
	Drift Threshold (lb)	10000 >
	Drift Time	10 >
	Noise	<input type="checkbox"/> OFF
	Noise Threshold (lb)	200 >

1. Enter the configuration menu and select **Scales**.
2. Select **Setup**.
3. Adjust error thresholds.

**Note** *The values are set up in Scale Units and when applicable the time period is set in seconds.*

#### Zero Reference

Zero Reference diagnostic only runs when total weight is less than **Zero Reference Threshold** and stable. It flags a difference greater than **Zero Reference Range** for longer than **Zero Reference Time**.

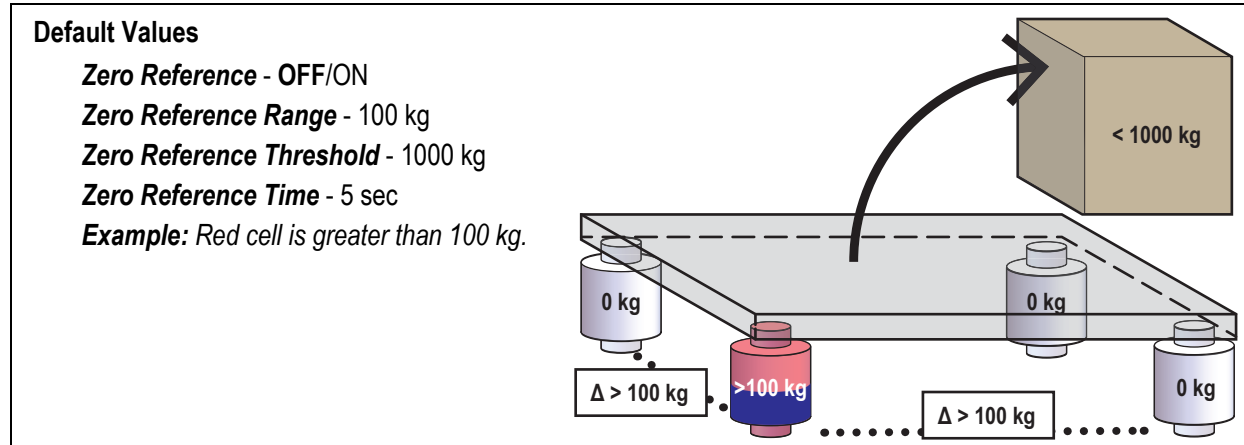

Figure 3-1. Zero Reference Diagnostic

#### Drift

Drift diagnostic only runs when the total scale weight is greater than **Drift Threshold** and stable. It flags a cell that continues to change more than **Drift Range** in **Drift Time**.

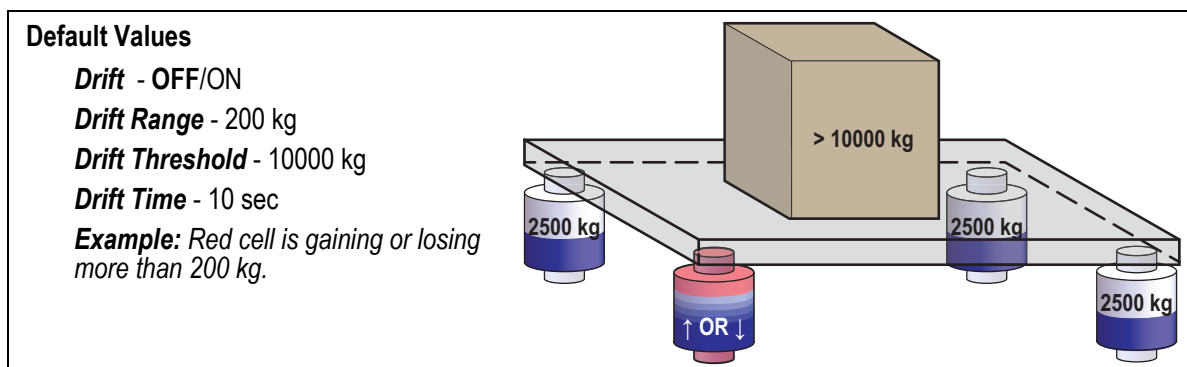

Figure 3-2. Drift Diagnostic

## Noise

Noise diagnostic runs continuously with any weight. It flags a cell that weight fluctuates a standard deviation of more than **Noise Range** in **Noise Time**.

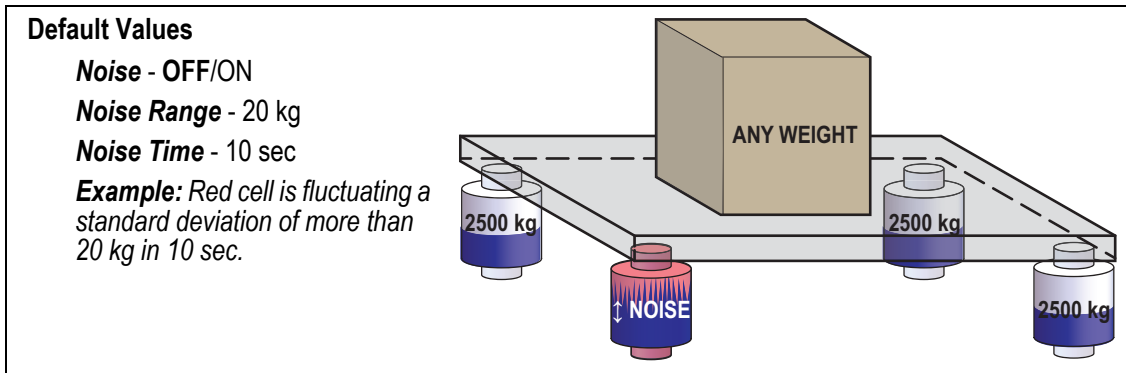

Figure 3-3. Noise Diagnostic

## Unbalance

Unbalance diagnostic only runs when the total scale weight is greater than **Unbalance Threshold** and stable. It flags a cell that is **Unbalance Range** more or less than adjacent cells.

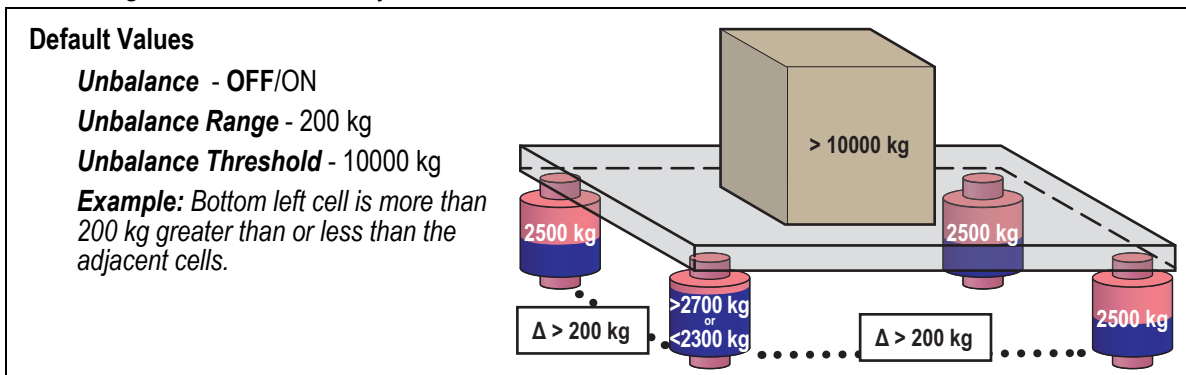

Figure 3-4. Unbalance Diagnostic

### 3.5.2 Add Diagnostics Softkey

The diagnostics softkey is a shortcut created for the weigh mode screen that, when pressed, displays the diagnostics page of the configuration menu as in [Section 3.5 on page 18](#). To add the diagnostics softkey:

	<ol style="list-style-type: none"> <li>1. Enter the configuration menu and select . <b>Softkeys</b> displays.</li> <li>2. Select <b>Add Softkey</b> icon to create new softkey.</li> <li>3. Scroll down to select <b>Diagnostics</b>.</li> </ol>
	<ol style="list-style-type: none"> <li>4. Scroll up to select <b>Done</b>.</li> <li>5. Select <b>Save and Exit</b>.</li> </ol>

## 3.6 Alert History

The 1280 Enterprise Indicator maintains a log of alerts sent by the Digital Load Cells. To access Digital Load Cell alert log:

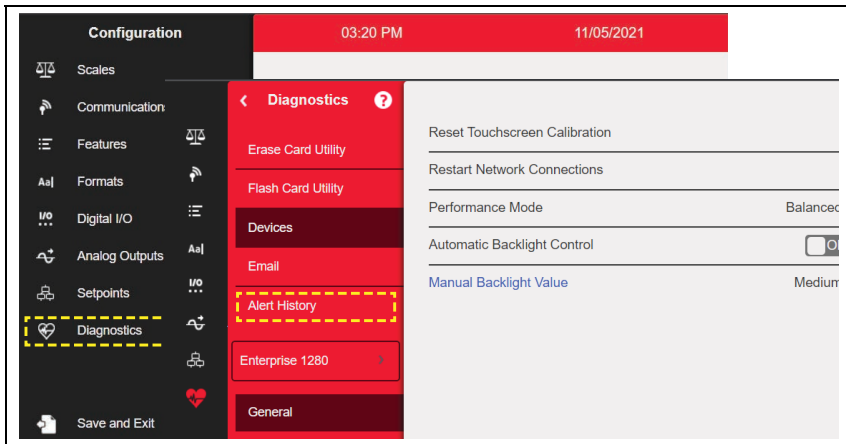
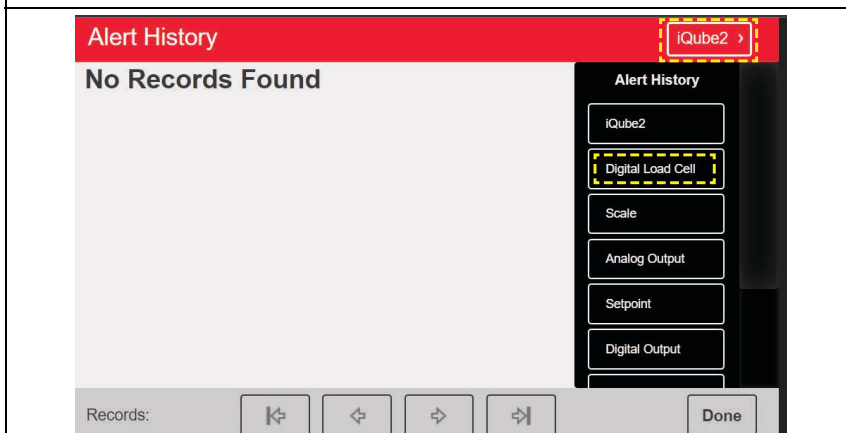
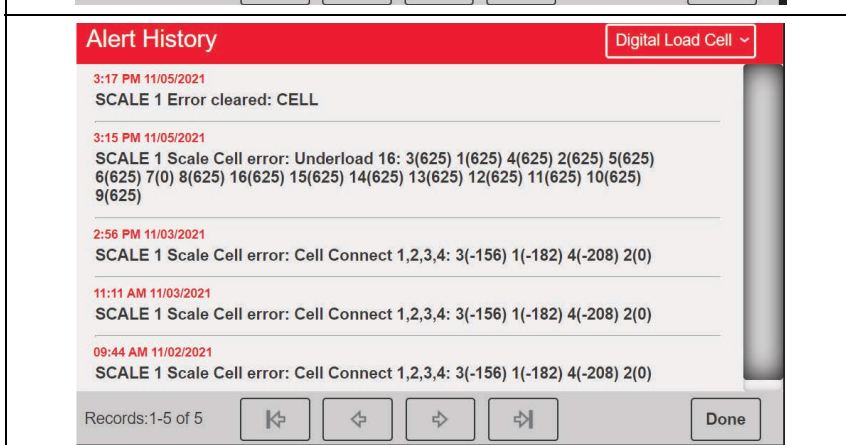
 <p>The screenshot shows the 'Configuration' menu on the left. The 'Diagnostics' option is highlighted with a red dashed box. The 'Enterprise 1280' option is also highlighted with a red dashed box. The right side of the screen shows various system settings like 'Reset Touchscreen Calibration', 'Restart Network Connections', and 'Performance Mode'.</p>	<ol style="list-style-type: none"> <li>1. Enter the configuration menu and Select <b>Diagnostics</b>.</li> <li>2. Select <b>Alert History</b>.</li> </ol>												
 <p>The screenshot shows the 'Alert History' screen. The title bar says 'Alert History' and 'No Records Found'. A red dashed box highlights the 'iQube2' button in the top right corner. A pop-up menu is visible on the right, with 'Digital Load Cell' highlighted by a red dashed box. Other options in the menu include 'Scale', 'Analog Output', 'Setpoint', and 'Digital Output'. Navigation buttons and a 'Done' button are at the bottom.</p>	<ol style="list-style-type: none"> <li>3. Select button in upper right corner of the screen. Pop out menu displays.</li> <li>4. Select <b>Digital Load Cell</b>.</li> </ol>												
 <p>The screenshot shows the 'Alert History' screen for 'Digital Load Cell'. It displays a list of error records with timestamps and descriptions. The records are grouped by time. Navigation buttons and a 'Done' button are at the bottom.</p> <table border="1"> <thead> <tr> <th>Timestamp</th> <th>Error Description</th> </tr> </thead> <tbody> <tr> <td>3:17 PM 11/05/2021</td> <td>SCALE 1 Error cleared: CELL</td> </tr> <tr> <td>3:15 PM 11/05/2021</td> <td>SCALE 1 Scale Cell error: Underload 16: 3(625) 1(625) 4(625) 2(625) 5(625) 6(625) 7(0) 8(625) 16(625) 15(625) 14(625) 13(625) 12(625) 11(625) 10(625) 9(625)</td> </tr> <tr> <td>2:56 PM 11/03/2021</td> <td>SCALE 1 Scale Cell error: Cell Connect 1,2,3,4: 3(-156) 1(-182) 4(-208) 2(0)</td> </tr> <tr> <td>11:11 AM 11/03/2021</td> <td>SCALE 1 Scale Cell error: Cell Connect 1,2,3,4: 3(-156) 1(-182) 4(-208) 2(0)</td> </tr> <tr> <td>09:44 AM 11/02/2021</td> <td>SCALE 1 Scale Cell error: Cell Connect 1,2,3,4: 3(-156) 1(-182) 4(-208) 2(0)</td> </tr> </tbody> </table>	Timestamp	Error Description	3:17 PM 11/05/2021	SCALE 1 Error cleared: CELL	3:15 PM 11/05/2021	SCALE 1 Scale Cell error: Underload 16: 3(625) 1(625) 4(625) 2(625) 5(625) 6(625) 7(0) 8(625) 16(625) 15(625) 14(625) 13(625) 12(625) 11(625) 10(625) 9(625)	2:56 PM 11/03/2021	SCALE 1 Scale Cell error: Cell Connect 1,2,3,4: 3(-156) 1(-182) 4(-208) 2(0)	11:11 AM 11/03/2021	SCALE 1 Scale Cell error: Cell Connect 1,2,3,4: 3(-156) 1(-182) 4(-208) 2(0)	09:44 AM 11/02/2021	SCALE 1 Scale Cell error: Cell Connect 1,2,3,4: 3(-156) 1(-182) 4(-208) 2(0)	<ol style="list-style-type: none"> <li>5. Digital Load Cell <b>Alert History</b> displays. <ul style="list-style-type: none"> <li>← Displays most recent errors.</li> <li>← and → Navigate one page at a time.</li> <li>⇌ Displays oldest errors</li> </ul> </li> </ol> <p><b>Note</b> Errors are shown in groups of five.</p> <ol style="list-style-type: none"> <li>6. Press <b>Done</b> to exit.</li> </ol>
Timestamp	Error Description												
3:17 PM 11/05/2021	SCALE 1 Error cleared: CELL												
3:15 PM 11/05/2021	SCALE 1 Scale Cell error: Underload 16: 3(625) 1(625) 4(625) 2(625) 5(625) 6(625) 7(0) 8(625) 16(625) 15(625) 14(625) 13(625) 12(625) 11(625) 10(625) 9(625)												
2:56 PM 11/03/2021	SCALE 1 Scale Cell error: Cell Connect 1,2,3,4: 3(-156) 1(-182) 4(-208) 2(0)												
11:11 AM 11/03/2021	SCALE 1 Scale Cell error: Cell Connect 1,2,3,4: 3(-156) 1(-182) 4(-208) 2(0)												
09:44 AM 11/02/2021	SCALE 1 Scale Cell error: Cell Connect 1,2,3,4: 3(-156) 1(-182) 4(-208) 2(0)												

### 3.7 EDP Commands

Command	Description	Input or Output Values
NCELLS	Load cells assigned to this scale	Comma separated list of load cell numbers 1-32
SIM	Indicates which load cell is to be emulated	Enumerated type 1-32
LC.ALIAS	Load cell alias	String
LC.TRIM	Trim value	Real, 0.0–5.0; default 1.0
LC.SLAVEADDRESS	Slave address	Integer, 0–247; default 0
LC.POINTSATCAPACITY	Points at capacity	Integer, 1–1,000,000; default 70,000
LC.CAPACITY	Capacity	Real, 0.0–100,000.0; default 10,000
DIA.FLAGS	Returns an encoded field showing all types of detected diagnostic errors	Mask bits for error types: Cell connect – 0x01, Zeroref – 0x02, Overload – 0x04, Drift – 0x08, Underload – 0x10, Noise – 0x20, Unbalanced – 0x40
DIA.CELLCONNECT	Returns each load cell for which a connect error has been detected	Example output: SCALE1 1 3 4
DIA.ZREF	Returns information on each load cell for which a Zero Reference error has been detected	Configured threshold for the diagnostic, each load cell and its current weight value; Example output: SCALE1 1000.0 1:100.0 4:103.4
DIA.OVERLOAD	Returns each load cell for which an overload has been detected	Example output: SCALE1 1 5
DIA.DRIFT	Returns information the load cell for which a Drift error has been detected	Configured threshold for the diagnostic, the load cell and its current weight value; Example output: SCALE1 200.0 2:205.3
DIA.UNDERLOAD	Returns each load cell for which an Underload has been detected	Example output: SCALE1 2 4
DIA.NOISE	Returns information on the load cell for which a Noise error has been detected	Configured threshold for the diagnostic, the load cell and its current weight value; Example output: SCALE1 200.0 3:202.4
DIA.UNBAL	Returns information on each load cell for which an unbalanced error has been detected	Message includes the configured threshold for the diagnostic, each load cell and its current weight value; Example output: SCALE1 5000.0 2:303.5 4:310.0

Table 3-2. Digital Load Cell Commands

## 4.0 Specifications

### RL5426DC

#### Transmission Speed

100 kHz (max)

#### Current Consumption

35 mA

#### Conversions Per Second

40 s

#### Material/Finish

Stainless steel

#### Certified Temperature

-10° C to 40° C

#### Operating Temperature

-35° C to 70° C

#### Seal Type

Hermetically sealed, IP68

#### Rated Excitation

15 VDC/ 8 ÷ 15

#### Vmin

Emax/18000

#### Insulation Resistance

5000 Megohms

#### Cable Length

4 m, 7 m, 9 m, 15 m, 25 m, 50 m

#### Cable Construction

Polyurethane

#### Warranty

Two-year limited warranty

#### Certifications



Certificate No. TC11699  
According to OIML R60 (2000) and  
OIML R76 6000e C6

### RL5416DC

#### Transmission Speed

100 kHz (max)

#### Current Consumption

35 mA

#### Conversions Per Second

40 s

#### Material Finish

Stainless steel

#### Certified Temperature

-10° C to 40° C

#### Operating Temperature

-35° C to 70° C

#### Seal Type

Hermetically sealed, IP68

#### Rated Excitation

15 V

#### Vmin

Emax/18000

#### Insulation Resistance

>5000 megohms

#### Cable Length

4 m, 7 m, 9 m, 15 m, 25 m, 50 m

#### Cable Construction

PVC

#### Warranty

Two-year limited warranty

#### Certifications



Certificate No. TC11637  
According to OIML R60 (2000) and  
OIML R76 4000e C4



# EU DECLARATION OF CONFORMITY

EU-KONFORMITÄTSERKLÄRUNG  
DÉCLARATION UE DE CONFORMITÉ

Rice Lake Weighing Systems  
230 West Coleman Street  
Rice Lake, Wisconsin 54868  
United States of America



**Type/Typ/Type:** 1280 Series

- English We declare under our sole responsibility that the products to which this declaration refers to, is in conformity with the following standard(s) or other regulations document(s).
- Deutsch Wir erklären unter unserer alleinigen Verantwortung, dass die Produkte auf die sich diese Erklärung bezieht, den folgenden Normen und Regulierungsbestimmungen entsprechen.
- Francais Nous déclarons sous notre responsabilité que les produits auxquels se rapporte la présente déclaration, sont conformes à la/aux norme/s suivante ou au/aux document/s normatif/s suivant/s.

EU Directive	Certificates	Standards Used / Notified Body Involvement
2014/35/EU low voltage	-	EN 62368-1:2014 + A11:2017
2014/30/EU EMC	-	EN 55022:2010 + AC:2011, EN 61000-6-2:2005 + AC:2005, EN 61326-1:2012
2014/53/EU Radio	-	EN 301489-17:2012, EN301489-1:2011, EN 300328 V2.1.1
2011/65/EU RoHS	-	EN 50581:2012

Signature: Brandi Harder  
 Name: Brandi Harder  
 Title: Quality Manager

Place: Rice Lake, WI USA  
 Date: February 7, 2021



# UK DECLARATION OF CONFORMITY

Rice Lake Weighing Systems  
 230 West Coleman Street  
 Rice Lake, Wisconsin 54868  
 United States of America



Type: 1280 Series

English We declare under our sole responsibility that the products to which this declaration refers to, is in conformity with the following standard(s) or other regulations document(s).

UK Regulations	Certificates	Standards Used / Approved Body Involvement
2016/1101 Low Voltage	-	EN 62368-1:2014 + A11:2017
2016/1091 EMC	-	EN 55022:2010 + AC:2011, EN 61000-6-2:2005 + AC:2005, EN 61326-1:2012
2017/1206 Radio	-	EN 301489-17:2012, EN301489-1:2011, EN 300328 V2.1.1
2012/3032 RoHS	-	EN 50581:2012

Signature: Brandi Harder

Place: Rice Lake, WI USA

Name: Brandi Harder

Date: February 7, 2021

Title: Quality Manager







© Rice Lake Weighing Systems Specifications subject to change without notice.

230 W. Coleman St. • Rice Lake, WI 54868 • USA  
U.S. 800-472-6703 • Canada/Mexico 800-321-6703 • International 715-234-9171 • Europe +31 (0)26 472 1319