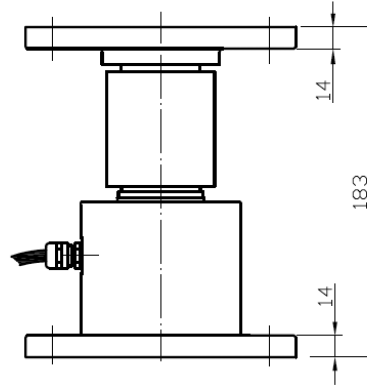

Heavy Capacity Pendulum Mount Tank, Hopper and Vessel Weighing

Applications

- Heavy capacity tanks, blenders, reactors and bulk inventory management
- Petroleum refining process control
- Chemical blending/batching

**Mount Only. Does Not Include Load Cell**

The RL964 mount is a low-profile compression load cell with auto-adjusting mount. Ideal for process control, batch weighing, silo/hopper and best scale applications with the built-in protection against lateral forces. Nickel or stainless steel mounts in pendulum-mount design.

Order Information

Nominal Capacity	Part #	Price
Nickel		
40t	161263	Consult
50t	161269	Consult
75t	161275	Consult
100t	161281	Consult
200t	161287	Consult
Stainless steel		
50t	161270	Consult
75t	161276	Consult
100t	161282	Consult
200t	161288	Consult

Dimensions

Rated Capacity	A	B	C	D	E
mm					
Pendulum Support	183	12	12	85	150