

RL932 (Square Top)

Medium to Heavy Capacity

Applications

- Medium to heavy capacity tanks, blenders, reactors and bulk inventory management
- Petroleum refining process control
- Chemical blending/batching

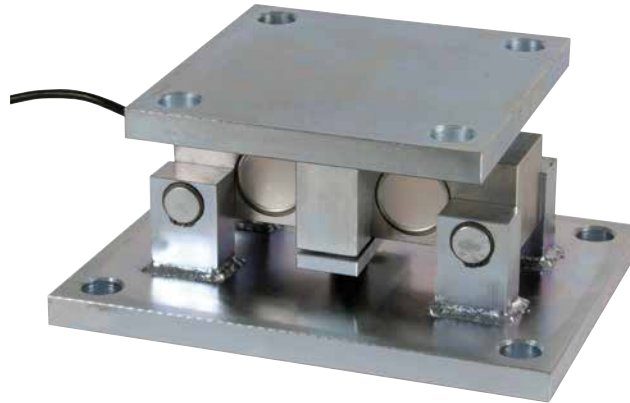

Mount Only. Does Not Include Load Cell

The RL93 Series mounting assembly utilizes the RL93 load cell and foot plate to provide an unmatched level of performance in tank and hopper weighing applications. The RL93 Series mount is ideally suited for indoor and outdoor process control operations with medium to heavy capacities. Modules are available with ball mount, round or square mount, nickel-plated or stainless steel construction.

Order Information: Stainless Steel

Nominal Capacity	Part #	Price
Square / stainless steel / RL932S		
5 - 25 t	161179	Consult
10t	161185	Consult
15t	161191	Consult
20t	161197	Consult
25t	161203	Consult

Order Information: Nickel

Nominal Capacity	Part #	Price
Square / nickel / RL932N		
5t	161178	Consult
10t	161184	Consult
15t	161190	Consult
20t	161196	Consult
25t	161202	Consult

Note: Refer to page 237 for load cell information

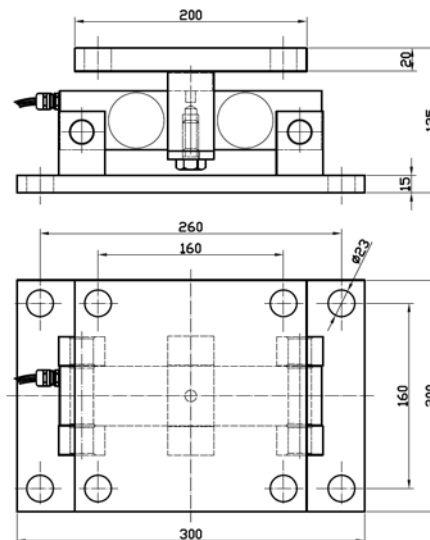

RL932