

RL-MWF

Lift Truck Mobile Weighing Forks



The RL-MFW is designed for light duty indoor use to accurately weigh pallets throughout warehouse environments with Legal for Trade approved accuracy. Install on any forklift carriage class type Fem IIA or IIIA using a DIN 15173 FEM holder plate. Provides legal weight without derating lift truck capacity.

RL-MWF includes a pair of forks with rechargeable battery and RLT-300 weight indicator mounted on one fork to allow for ease of installation. Optional in-cab indicator provides access to weighing functionality, via Bluetooth®.

Standard Features

Weighing Forks:

- Four shear beam IP68 load cells
- Painted steel forks
- 0,05% of nominal capacity
- Includes inclinometer

Integrated RLT-300 Indicator:

- Six-digit backlit LCD display, h=25 mm
- Steel housing
- Waterproof keyboard functions
 - o Zero
 - o Semi automatic or preset tare
 - o Function mode
 - o Print or data transmission
 - o On/Off
- Rechargeable battery operation:
 - o Provides power to fork mounted indicator and weighing forks
 - o IP 65
 - o Operating time of approximately 40 hours continuous use on included rechargeable battery kit
 - o Programmable auto off feature
 - o Battery charger included, 230VAC 50/60 Hz, approx. 8 hours charge time
- Function modes:
 - o High resolution x 10 display
 - o Net/Gross
 - o Meter and litre counter function with conversion factor
 - o Weigh totalizing
 - o Formula weighing
 - o +/- checkweighing with quick target and threshold input
 - o Percentage weighing
 - o Percentage batching with programmable target
 - o Piece counter
 - o Hold

APPROVALS



Specifications

Carriage Class Type:

RL-MWF 1125 AM-2 – Fem IIA
RL-MWF 1150 AM-2 – Fem IIIA

Capacity and Resolution (Dual Range):

RL-MWF 1125 AM-2:

0 – 1.000 x 2 kg / 1.000 – 2.500 x 5 kg (approved)
0 – 500 x 1 kg / 500 – 1.000 x 2 kg / 1.000 – 2.500 x 5 kg

RL-MWF 1150 AM-2:

0 – 2.500 x 5 kg / 2500 – 5.000 x 10 kg (approved)
0 – 1.000 x 2 kg / 1.000 – 2.500 x 5 kg / 2.500 – 5.000 x 10 kg

Accuracy:

0,05% of nominal capacity

Fork Weight:

RL-MWF 1125 AM-2 – 75 kg each
RL-MWF 1150 AM-2 – 90 kg each

Max Horizontal Inclination Accuracy:

+/- 2 degrees

Max Allowable Overload Protection:

200% of nominal capacity

Warranty:

1 year limited warranty

Part Number/Price

Part #	Description	Price
186143	RL-MWF 1125 AM-2 2500 kg capacity	Consult
186144	RL-MWF 1150 AM-2 5000 kg capacity	Consult
N/A	Approval	Consult

Options/Accessories

Part #	Description	Price
N/A	In-cab kit (display includes indicator, printer, mounting kit, USB storage and program)	Consult
186145	Optional spare battery kit	Consult
192278	Battery charger	Consult

RL-MWF 1125 AM-2 2500 kg Capacity FEM IIA

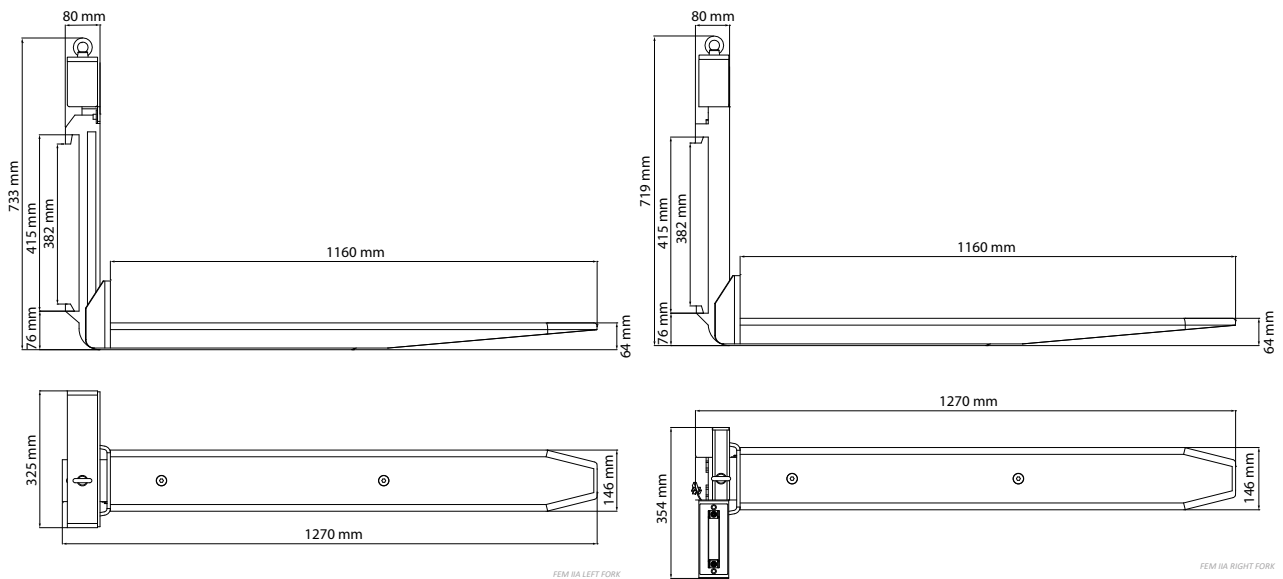

RL-MWF 1150 AM-2 5000 kg Capacity FEM IIIA

