

RL-MFLS

Mobile Forklift Scale



Forks not included

The RL-MFLS is designed for indoor use to accurately weigh pallets throughout warehouse environments with Legal for Trade approved accuracy. Install on any forklift carriage class type Fem II using a DIN 15173 FEM holder plate.

RL-MFLS includes carriage plate scale assembly and battery-powered RLT-300 indicator with cabled connection. Includes tilt sensor for approval purposes.

Standard Features

Weighing Carriage:

- Two shear beam IP68 stainless steel load cells
- Hermetically sealed junction box

Cab-Mounted RLT-300 Indicator:

- Six-digit backlit LCD display, h=25 mm
- ABS housing – IP68
- Waterproof keyboard functions
 - o Zero
 - o Semi automatic or preset tare
 - o Function mode
 - o Print or data transmission
 - o On/Off
- Forklift cab mounting bracket
- Rechargeable battery operation
 - o Provides power to indicator and carriage
 - o Operating time of approximately 40 hours continuous use on included rechargeable battery kit
 - o Programmable auto off feature
 - o Battery charger included
- Function modes
 - o High resolution x 10 display
 - o Net/Gross
 - o Meter and litre counter function with conversion factor
 - o Weigh totalizing
 - o Formula weighing
 - o +/- checkweighing with quick target and threshold input
 - o Percentage weighing
 - o Percentage batching with programmable target
 - o Piece counter
 - o Hold

APPROVALS



Specifications

Carriage Class Type:

RL-MFLS 15A - Fem IIA

Capacity and Resolution (Dual Range):

RL-MFLS 15A:

0 – 600 x 1 kg / 600 – 1.500 x 2 kg (approved)
 0 – 600 x 0,2 kg / 600 – 1.500 x 0,5 kg

RL-MFLS 25A:

0 – 1.500 x 2 kg / 600 – 2.500 x 5 kg (approved)
 0 – 1.500 x 0,5 kg / 1.500-2.500 x 1 kg

Carriage Weight:

190 kg

Accuracy:

0,05% of nominal capacity

Max Horizontal Inclination Accuracy:

+/- 2 degrees

Max Barycentric Shifting:

55 mm

Warranty:

1 year limited warranty

Part Number/Price

Part #	Description	Price
186151	RL-MFLS – 15A 1500 kg capacity kit (includes RLT-300 indicator, tilt sensor, mounting bracket and extension cable) Includes calibration	Consult
192377	RL-MFLS – 25A 2500 kg capacity kit (includes RLT-300 indicator, tilt sensor, mounting bracket and extension cable) Includes calibration	Consult
N/A	Approval	Consult

Plate Type: FEM 2
Thickness: 110 mm
Barycentre: 55 mm
Equipment Weight: 190 kg
Nominal Capacity: 2.500 kg with load's barycentre at 500 mm from the back of the forks

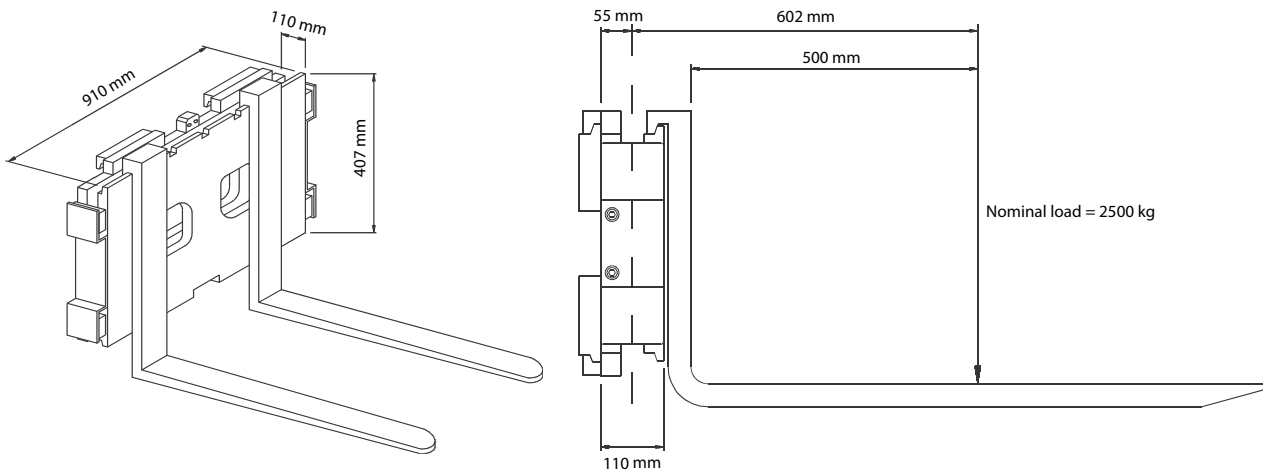

Replacement Parts

Part #	Description	Price
186156	Extension cable assembly	Consult