

482/482 Plus Legend™ Series

Digital Weight Indicator



Standard Features

- LCD backlit display, 20 mm, six-digit, seven-segment
- Time and date, battery-backed
- Local/remote operation
- Numeric keypad (482 Plus)
- Keyed entries for setpoint values (482 Plus)
- Two independent serial ports, RS-232 and 20 mA
- NEMA Type 4X/IP66 stainless steel washdown enclosure
- Programmable ticket formats for gross, net, accumulator and setpoints
- Five continuous stream formats
- Adaptive filter or rolling average filter
- Configurable with Revolution® software
- Operator functions through menu for audit trail, preset tare, unit ID, accumulator, time and date, setpoints, communications and print formats
- Eight setpoints, sequenced batch engine

Options

- Analog output, 0-10 VDC, 0-20 mA, 4-20 mA, selection for 20% offset
- Relay output, two digital inputs, four dry contact relays (supports 2 boards)
- Ethernet TCP/IP and USB interface (requires cable)
- Battery, rechargeable lithium ion
Power for 40 hours of battery life on one 350 ohm load
Power-saving modes for sleep and wake-up threshold

Approvals



Measurement
Canada
Approved



Specifications

Power:

Line voltages: 100-240 VAC
Frequency: 50-60 Hz
DC voltages: n/a
Power Consumption: 8 W

Excitation Voltage:

5 VDC, 8 x 350Ω or 16 x 700Ω load cells

Analog Signal Input Range:

±7 mV/V

Analog Signal Sensitivity:

0.1 μV/graduation minimum
0.5 μV/graduation recommended

A/D Sample Rate:

5, 10, 20, 40 Hz, software selectable

Resolution:

Internal: 523,000 counts
Display: 100,000 graduations

System Linearity / PI Rating:

Within 0,01% of full scale

Digital I/O:

RFI capacitor bypass and ESD suppressors

Communication Ports:

Com 1: RS-232 full duplex
Com 2: RS-232 full duplex or 20 mA simplex, continuous
Both ports 1200, 2400, 4800, 9600, 19200, 38400
baud seven or eight data bits, even, odd or no parity

(Optional) Analog Output:

16-bit resolution, voltage output 0-10 VDC, current output 0-20 mA / 4-20 mA

(Optional) Relay Board:

Two opto-isolated, 5 to 24 VDC, active high inputs.
Two inputs (requires relay output option). Primary keys, pseudo functions, batching functions.
(4) 30 VDC, 2 amp dry-contact relays

(Optional) Ethernet and USB Board:

USB five-pin header for PC, printer or flash drive.
Ethernet TCP/IP, RJ45 jack, server and client ports.

Display:

LED display, 20 mm, six-digit, seven-segment

Status Annunciators:

Gross, net, center of zero, stand still, lb, kg, tare, preset tare

Keys/Buttons:

Flat membrane panel, embossed keys, tactile feel

Temperature Range:

Certified: -10°C to 40°C
Operating: -10°C to 50°C

Weight:

3 kg

Rating/Material:

Enclosure: NEMA Type 4X/IP66, heavy-gauge stainless steel

Warranty:

Two-year limited warranty

EMC Immunity:

EN 50082 Part 2 IEC EN 61000-4-2, 3, 4, 5, 6, 8, and 11

Approvals:

OIML R76/2006-NL1-12.48,
EU Test Certificate TC8322
Accuracy Class III, 10,000d
CE Marked
Measurement Canada AM-5892,
Accuracy Class III/IIHD, 10,000d
NTEP CC 12-123, Accuracy Class III/IIIL, 10,000d
UL/cUL Listed

482/482 Plus Legend™ Series

Digital Weight Indicator

Part Number/Price: 482

Part #	Description	Est. Weight	Price
482 90-264 VAC ††			
164672	482 LCD	4 kg	Consult
164583	482 LCD with internal battery	4 kg	Consult

Part Number/Price: 482 Plus

Part #	Description	Est. Weight	Price
482 Plus 90-264 VAC ††			
164673	482 Plus LCD	4 kg	Consult
164586	482 Plus LCD with internal battery	4 kg	Consult



†† CEE 7/7 plug (Euro)

Options/Accessories

Part #	Description	Price
131340	Mounting bracket for option boards	Consult
131341	Analog output, 0-10 VDC, 4-20 mA (requires 131340)	Consult
131342	Relay board, two digital inputs, four dry contact outputs (requires 131340)	Consult
164600	USB and Ethernet TCP/IP (requires 131340)	Consult
164604	Ethernet cable with cord grip, 1,8 m	Consult
164602	USB cable with cord grip, type A female, 152 mm	Consult
167707	USB cable with cord grip, type A male, 1,8 m	Consult
167708	USB cable with cord grip, type B male, 1,8 m	Consult
165379	Flash update cable	Consult
151100	A/D sealing kit, used with audit trail tracking	Consult
151099	Panel mount bezel (not NEMA Type rated)	Consult
83564	Clear protective overlay (package of five)	Consult
77925*	Revolution® scale software, CD	Consult
165124	Installation manual	Consult
Primary Replacement Components		
161048	Overlay, 482 6-key, green window	Consult
161049	Overlay, 482 Plus with numeric keys, green window	Consult
153776	Display board, LCD	Consult
131316	Power supply, 85-265 VAC	Consult
131318	CPU board	Consult
131319	A/D board	Consult

* Revolution can be downloaded for free at www.ricelake.com

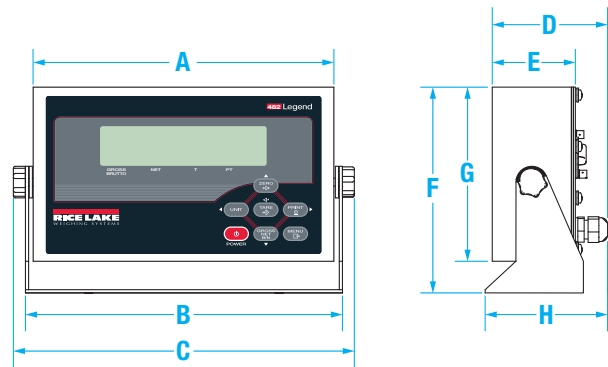

Dimensions

A	241 mm	D	92 mm	G	152 mm
B	254 mm	E	70 mm	H	95 mm
C	279 mm	F	178 mm		